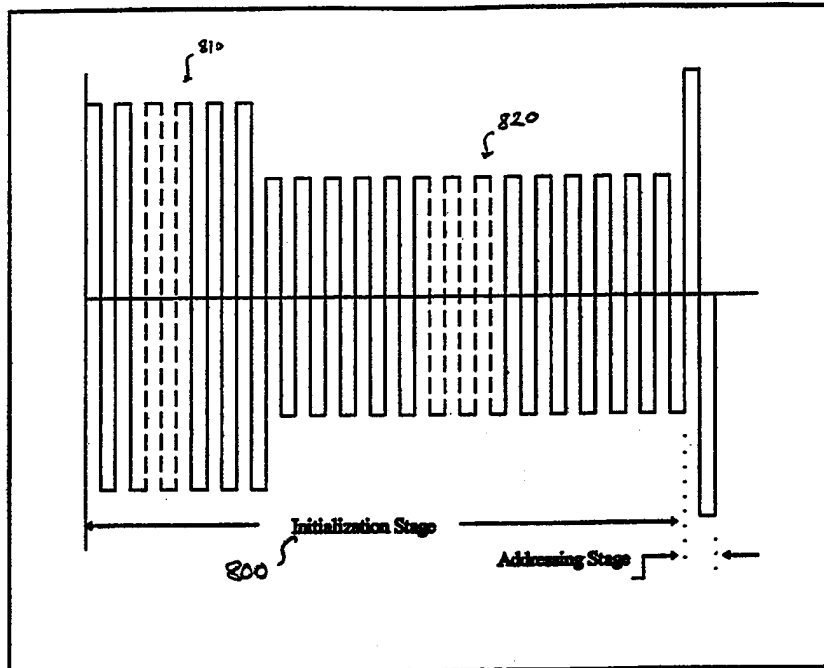




INTERNATIONAL APPLICATION PUBLISHED UNDER THE PATENT COOPERATION TREATY (PCT)

<p>(51) International Patent Classification ⁶ : G09G 3/36</p>	<p>A1</p>	<p>(11) International Publication Number: WO 98/31002 (43) International Publication Date: 16 July 1998 (16.07.98)</p>
<p>(21) International Application Number: PCT/US98/00108 (22) International Filing Date: 6 January 1998 (06.01.98) (30) Priority Data: 08/780,315 8 January 1997 (08.01.97) US (71) Applicant: ADVANCED DISPLAY SYSTEMS, INC. [US/US]; Building 1, 10901 Airport Boulevard, Amarillo, TX 79111 (US). (72) Inventors: WU, Bao-Gang; 4005 Celia Street, Amarillo, TX 79121 (US). GAO, Jianmi; 1609 Richforest, Richardson, TX 75081 (US). ZHAO, Meng; 7325 Angel Fire Drive, Plano, TX 75025 (US). (74) Agent: CHWANG, T., Ling; Hitt Chwang & Gaines, P.C., 225 University Plaza, 225 W. Campbell Road, Richardson, TX 75080 (US).</p>		<p>(81) Designated States: AL, AM, AT, AU, AZ, BA, BB, BG, BR, BY, CA, CH, CN, CU, CZ, DE, DK, EE, ES, FI, GB, GE, GM, GW, HU, ID, IL, IS, JP, KE, KG, KP, KR, KZ, LC, LK, LR, LS, LT, LU, LV, MD, MG, MK, MN, MW, MX, NO, NZ, PL, PT, RO, RU, SD, SE, SG, SI, SK, SL, TJ, TM, TR, TT, UA, UG, UZ, VN, ZW, ARIPO patent (GH, GM, KE, LS, MW, SD, SZ, UG, ZW), Eurasian patent (AM, AZ, BY, KG, KZ, MD, RU, TJ, TM), European patent (AT, BE, CH, DE, DK, ES, FI, FR, GB, GR, IE, IT, LU, MC, NL, PT, SE), OAPI patent (BF, BJ, CF, CG, CI, CM, GA, GN, ML, MR, NE, SN, TD, TG).</p> <p>Published <i>With international search report. Before the expiration of the time limit for amending the claims and to be republished in the event of the receipt of amendments.</i></p>

(54) Title: APPARATUS FOR AND METHOD OF DRIVING A CHOLESTERIC LIQUID CRYSTAL FLAT PANEL DISPLAY WITH INITIAL SETTING INTO THE NEMATIC STATE



(57) Abstract

Driver apparatus and methods of driving at least a portion of a cholesteric liquid crystal ("CLC") panel to a state having a given reflectivity. One of the methods includes the steps of: (1) initially driving the portion to a nematic phase, (2) subsequently driving the portion to a cholesteric phase focal-conic state, the cholesteric phase focal-conic state providing a known reference state for subsequent driving of the portion and (3) thereafter driving the portion to the state having the given reflectivity.

FOR THE PURPOSES OF INFORMATION ONLY

Codes used to identify States party to the PCT on the front pages of pamphlets publishing international applications under the PCT.

AL	Albania	ES	Spain	LS	Lesotho	SI	Slovenia
AM	Armenia	FI	Finland	LT	Lithuania	SK	Slovakia
AT	Austria	FR	France	LU	Luxembourg	SN	Senegal
AU	Australia	GA	Gabon	LV	Latvia	SZ	Swaziland
AZ	Azerbaijan	GB	United Kingdom	MC	Monaco	TD	Chad
BA	Bosnia and Herzegovina	GE	Georgia	MD	Republic of Moldova	TG	Togo
BB	Barbados	GH	Ghana	MG	Madagascar	TJ	Tajikistan
BE	Belgium	GN	Guinea	MK	The former Yugoslav Republic of Macedonia	TM	Turkmenistan
BF	Burkina Faso	GR	Greece			TR	Turkey
BG	Bulgaria	HU	Hungary	ML	Mali	TT	Trinidad and Tobago
BJ	Benin	IE	Ireland	MN	Mongolia	UA	Ukraine
BR	Brazil	IL	Israel	MR	Mauritania	UG	Uganda
BY	Belarus	IS	Iceland	MW	Malawi	US	United States of America
CA	Canada	IT	Italy	MX	Mexico	UZ	Uzbekistan
CF	Central African Republic	JP	Japan	NE	Niger	VN	Viet Nam
CG	Congo	KE	Kenya	NL	Netherlands	YU	Yugoslavia
CH	Switzerland	KG	Kyrgyzstan	NO	Norway	ZW	Zimbabwe
CI	Côte d'Ivoire	KP	Democratic People's Republic of Korea	NZ	New Zealand		
CM	Cameroon		Republic of Korea	PL	Poland		
CN	China	KR	Republic of Korea	PT	Portugal		
CU	Cuba	KZ	Kazakstan	RO	Romania		
CZ	Czech Republic	LC	Saint Lucia	RU	Russian Federation		
DE	Germany	LI	Liechtenstein	SD	Sudan		
DK	Denmark	LK	Sri Lanka	SE	Sweden		
EE	Estonia	LR	Liberia	SG	Singapore		

APPARATUS FOR AND METHOD OF DRIVING A CHOLESTERIC LIQUID
CRYSTAL FLAT PANEL DISPLAY WITH INITIAL SETTING INTO THE
NEMATIC STATE

TECHNICAL FIELD OF THE INVENTION

The present invention is directed, in general, to liquid crystal displays and, more specifically, to an apparatus for and method of driving a cholesteric liquid crystal ("CLC") flat panel display.

BACKGROUND OF THE INVENTION

5 The development of improved liquid crystal ("LC") flat-panel displays is an area of very active research, driven in large part by the proliferation of and demand for portable electronic appliances, including computers and wireless telecommunications devices. Moreover, as the quality of LC displays improves, and the cost of manufacturing declines,
10 it is projected that LC displays may eventually displace conventional display technologies, such as cathode-ray-tubes.

 Cholesteric liquid crystal ("CLC") technology is a particularly-attractive candidate for many display applications. Cholesteric liquid crystals may be used to provide bi-stable and multi-stable displays that,
15 due to their non-volatile "memory" characteristic, do not require a continuous driving circuit to maintain a display image, thereby significantly reducing power consumption. Moreover, some CLC displays may be easily viewed in ambient light without the need for back-lighting. The elimination of the need for back-lighting is particularly

capable of displaying full-motion video will eventually displace conventional cathode-ray tubes in television and computer display applications. Several characteristics of conventional CLC materials and driving circuits, however, present limitations to achieving CLC displays that can be driven fast enough to support the frame rates necessary to display full-motion video.

CLC displays are constructed by trapping a thin film of liquid crystal between two substrates of glass or transparent plastic. The substrates are usually manufactured with transparent electrodes, typically made of indium tin oxide ("ITO"), to which electrical "driving" signals are coupled. The driving signals induce an electric field which can cause a phase change or state change in the CLC material; the CLC exhibiting different light-reflecting characteristics according to its phase and/or state.

CLCs can exhibit a field-induced "nematic" phase and a stable "cholesteric" phase. The field-induced "nematic" phase of a conventional CLC is a "non-stable" state, meaning that the CLC will not remain in that state if the electric field necessary to drive the CLC into the nematic phase is removed; *i.e.* upon removal of the electrical field, the CLC will transform to a "stable" cholesteric phase. Thus, to reduce display power requirements, conventional CLC displays are generally operated only in the stable cholesteric phase in which two different molecular domain structures (planar and focal-conic), or states, of the CLC are used to modulate incident light. When a CLC in the planar state is illuminated with ambient light, the CLC reflects light that is within an intrinsic spectral bandwidth centered about a wavelength λ_0 ; all other wavelengths of incident light are transmitted through the CLC. The wavelength λ_0 may be within the invisible or visible ("color") light spectrum; a CLC having an intrinsic wavelength in the infra-red spectrum being particularly useful in transmissive mode displays where the reflection of color to an

observer is not desired or necessary. By varying the proportion of chiral compound present in the CLC, this selective reflection can be achieved for any wavelength λ_0 within the infra-red and color spectrums. When the CLC is in the focal-conic state, the CLC optically scatters all
5 wavelengths of incident light; a substantial portion of the incident light being forward-scattered and a lesser portion being back-scattered.

The structure and operation of CLCs is not fully understood; empirical data, however, has provided a basis for different hypothetical models that can be used to characterize the response of a CLC to controlled stimuli. The principles of the present invention, however, are not limited by the model used herein to describe the structure and response of a CLC. As used hereinafter, "on" and "off" refer to the relative states of local domains within the CLC. Each pixel of a CLC may be composed of domains in a planar ("on") or focal-conic ("off")
10 state, or "texture;" the planar state corresponding to a maximum level of reflectivity and the focal-conic state corresponding to a minimum level of reflectivity. Furthermore, a multi-stable CLC is capable of displaying "gray scale" images, wherein each display pixel can be driven to a desired gray scale level by selectively driving the local domains to any
15 one of multiple stable intermediate states between the planar and focal-conic states; each intermediate state having a level of reflectivity between those of the planar and focal-conic states.

A driving signal can be selectively applied to a CLC to switch between the cholesteric-phase focal-conic and planar states. An important
25 characteristic of CLC materials in display applications is that the cholesteric-phase planar and focal-conic states are stable states; *i.e.* the state of the CLC does not change when the driving signal is removed. This characteristic of CLCs is generally referred to as "bi-stability" for two state (*e.g.* black and white) displays, and "multi-stability" for multi-

state (*e.g.* “grey scale”) displays. The stability, or “memory,” characteristic of CLCs eliminates the need to continually refresh the display as is required by other LC materials and cathode-ray tubes, thereby reducing power consumption. For full-motion video applications, however, a CLC display must be driven at a rate sufficient to display smooth transitions between video frames, referred to as the video “frame rate.”

Two approaches may be taken to increase the frame rate of conventional CLC displays. One approach, disclosed by Bao-Gang Wu, *et al.* in copending United States Patent application Serial No. 08/445,181, filed on May 19, 1995 (commonly assigned with the present application), incorporated herein by reference, is to improve the state transition characteristics of the CLC material by modifying the texture of the material. A second approach is to improve the method by which electrical drive signals are used to control the state transitions of the CLC.

United States Patent No. 5,453,863, issued to West, *et al.* on September 26, 1995, discloses the use of signals of varying electrical magnitudes to transform the CLC from focal-conic to planar states, and *vice versa*; a continuum of signal magnitudes being used to drive the CLC to intermediate “gray scale” states. As hereinafter described, the portion of a typical CLC electro-optical response curve corresponding to the intermediate (*i.e.* gray scale) states has a steep slope; *i.e.* the portion of the curve corresponds to a narrow voltage range over which signals of varying electrical magnitudes can be used to drive a CLC to different intermediate states. Because the voltage range is typically narrow, a principal disadvantage of the method disclosed by West, *et al.* is that it is difficult to precisely drive the CLC to a preferred intermediate state. Furthermore, the electro-optical response curve of a CLC will shift to the

left or right with variations in the cell gap (*i.e.* the thickness of the CLC). Because the portion of a typical CLC electro-optical response curve corresponding to the intermediate (*i.e.* gray scale) states has a steep slope, even a slight shift in the curve will cause a particular drive voltage to
5 produce different intermediate states in pixels having slightly different cell gaps.

Therefore, what is needed in the art is an apparatus for and method of driving a CLC flat panel display at full-motion video frame rates. Furthermore, there is a need in the art for an apparatus and method
10 of driving a CLC flat panel display to intermediate (gray scale) states, wherein the intermediate states are not a function of a drive signal voltage.

SUMMARY OF THE INVENTION

To address the above-discussed deficiencies of the prior art, it is a primary object of the present invention to provide a driver apparatus and methods of driving at least a portion of a cholesteric liquid crystal ("CLC") panel to a state having a given reflectivity, the apparatus and methods of driving suitable to drive a CLC display at full-motion video frame rates.

In the attainment of the above-described primary object, the present invention recognizes that a matrix CLC display may be driven faster when it is reset to a cholesteric phase focal-conic state prior to being driven to a final state of given reflectivity. The present invention initializes, or "resets," the one or more portions of a CLC display by initially driving the one or more portions to the nematic phase and subsequently driving the one or more portions to the cholesteric phase focal-conic state. In a conventional matrix display, the one or more portions correspond to the picture elements, or "pixels," of the matrix display. The cholesteric phase focal-conic state has known characteristics and, therefore, can be used to provide a known reference state for the subsequent driving of the portion to the desired state having the given reflectivity.

In one embodiment of the present invention, the step of initially driving comprises the step of applying a sequence of pulses to drive the portion to the nematic phase, and the step of subsequently driving comprises the step of applying a sequence of pulses to drive the portion to the cholesteric phase focal-conic state. As described hereinafter, initially driving the portion to the nematic phase and subsequently to the cholesteric phase focal-conic state has the advantage of increasing the

speed at which the display can be driven, as well as improving the quality of a display image.

In one embodiment of the present invention, the step of initially driving comprises the step of applying a first sequence of pulses having a first amplitude to drive the portion to the nematic phase and the step of subsequently driving comprises the step of applying a second sequence of pulses having a second amplitude to drive the portion to the cholesteric phase focal-conic state. The steps of applying the first and second sequence of pulses are referred to as an "initialization" stage, which erases the previous state of the portion in preparation for driving the portion to a new state in an "addressing" stage. In related embodiments, the first and second amplitudes are a function of a composition of CLC in the CLC panel and/or a function of a thickness of the CLC panel. The apparatus for and method of driving a CLC disclosed by the present invention is not limited to a particular CLC composition or CLC panel structure; the principles disclosed herein may be employed to advantage in many different CLC flat panel display structures using different CLC materials.

Following the selective initialization of portions of the CLC display, a portion of the display can be "addressed" by thereafter driving the state of the portion to a desired final state having a given reflectivity. In one embodiment of the present invention, the step of thereafter driving includes the step of applying an addressing pulse, or sequence of pulses, having a predetermined amplitude to drive the portion from the cholesteric phase focal-conic state to a cholesteric phase planar state. In a related embodiment, the desired state having a given reflectivity is an intermediate state between the cholesteric phase focal-conic state and a cholesteric phase planar state, and the step of thereafter driving includes the step of applying a sequence of addressing pulses having a

predetermined amplitude to drive the portion from the cholesteric phase focal-conic state to the intermediate state, the given reflectivity being a function of a duration of the sequence of addressing pulses. In another embodiment, the step of applying a sequence of addressing pulses having a predetermined amplitude is preceded by the step of applying a first sequence of pulses having an amplitude less than a minimum amplitude necessary to drive the CLC from the focal-conic state, a duration of the first sequence of pulses adjusted such that the sum of the duration of the first sequence of pulses and the duration of the sequence of addressing pulses equals a predetermined value.

The foregoing has outlined rather broadly the features and technical advantages of the present invention so that those skilled in the art may better understand the detailed description of the invention that follows. Additional features and advantages of the invention will be described hereinafter that form the subject of the claims of the invention. Those skilled in the art should appreciate that they may readily use the conception and the specific embodiment disclosed as a basis for modifying or designing other structures for carrying out the same purposes of the present invention. Those skilled in the art should also realize that such equivalent constructions do not depart from the spirit and scope of the invention in its broadest form.

BRIEF DESCRIPTION OF THE DRAWINGS

For a more complete understanding of the present invention, and the advantages thereof, reference is now made to the following descriptions taken in conjunction with the accompanying drawings, in which:

5 FIGURE 1-A illustrates a schematic representation of the helical twisted structure of a cholesteric liquid crystal ("CLC") molecule;

 FIGURE 1-B illustrates a schematic representation of a CLC domain;

10 FIGURE 2 illustrates a schematic representation of a CLC domain in a predominantly planar state;

 FIGURE 3 illustrates a schematic representation of a CLC domain in a predominantly focal-conic state;

15 FIGURE 4 illustrates a schematic representation of a CLC domain in an intermediate ("gray scale") state between a predominantly planar state and a predominantly focal-conic state;

 FIGURE 5 illustrates a schematic representation of a CLC in a field-induced nematic phase;

 FIGURE 6 illustrates an exemplary electro-optical response characteristic of a CLC;

20 FIGURE 7-A illustrates an exemplary electro-optical response characteristic of a CLC for a driving pulse having a pulse duration of 50 ms;

 FIGURE 7-B illustrates an exemplary electro-optical response characteristic of a CLC for a driving pulse having a pulse duration of 3 ms;

25 FIGURE 7-C illustrates an exemplary electro-optical response characteristic of a CLC for a driving pulse having a pulse duration of 1 ms;

FIGURE 7-D illustrates an exemplary electro-optical response characteristic of a CLC for a driving pulse having a pulse duration of 70 μ S;

5 FIGURE 8 illustrates exemplary waveforms and an exemplary timing sequence for a CLC driving apparatus and method according to the principles of the present invention;

FIGURE 9-A illustrates an exemplary first pulse sequence of an initialization waveform for a CLC driving apparatus and method according to the principles of the present invention;

10 FIGURE 9-B illustrates an exemplary second pulse sequence of an initialization waveform for a CLC driving apparatus and method according to the principles of the present invention;

FIGURE 10 illustrates exemplary column and row initialization signals for a frame initialization CLC driving method according to the principles of the present invention;

FIGURE 11 illustrates exemplary column and row polar addressing signals for a frame initialization CLC driving method according to the principles of the present invention;

20 FIGURE 12 illustrates exemplary column and row initialization and addressing signals for a multi-row CLC driving method according to the principles of the present invention;

FIGURE 13 illustrates an exemplary addressing waveform pulse sequence for a gray-scale CLC driving method according to the principles of the present invention;

25 FIGURE 14 illustrates an exemplary electro-optical response characteristic of a CLC for addressing waveform pulse sequences of different pulse sequence durations;

FIGURE 15 illustrates an exemplary apparatus for employing the method for driving a CLC display according to the principles of the present invention;

FIGURE 16-A illustrates the effect of temperature on the phase
5 change voltage V_r of an exemplary CLC; and

FIGURE 16-B illustrates the effect of temperature on the required driving time, according to the principles of the present invention, for an exemplary CLC.

DETAILED DESCRIPTION

Before describing the novel apparatus for and method of driving a cholesteric liquid crystal ("CLC") flat panel display disclosed by the present invention, a description of the various structures of CLC materials is necessary to appreciate the advantages of the present invention. Referring initially to FIGURE 1-A, illustrated is a schematic representation of the helical twisted structure of a CLC 100. A CLC helical structure 100 consists of molecular directors 110 that interact to produce a helical twisted structure having a pitch p ; the pitch p is predetermined by the amount of chiral material added to the CLC material. In FIGURE 1-A, the molecular directors 110 are shown as two-dimensional projections for each hypothetical layer; the different projected lengths of the directors illustrating the twisted structure of the CLC helical structure 100. A volume of CLC material consists of many CLC helical structures 100 arranged in "domains." FIGURE 1-B illustrates a schematic representation of a CLC domain. The helical axis of the CLC helical structure 100 is called the "domain director." A CLC matrix flat panel display includes many picture elements, or "pixels," each of which contain many CLC domains.

A CLC can be forced to change its structure by applying an electric field. Under the force of the applied electrical field, the domain directors are reoriented, resulting in various light-reflecting and light-scattering states. The light-reflecting planar state can exhibit a bright color and the light-scattering focal-conic state can exhibit a substantially black color, as hereinafter described. If the CLC display includes a plurality of separately-addressable pixels, the CLC display can be used to display text and/or images.

An important characteristic of CLCs is the existence of stable states even when no driving signal is applied; *i.e.* “zero field” conditions. A CLC can exhibit a stable light-reflective planar state, a stable light-scattering focal-conic state, and many stable intermediate (*i.e.* gray scale) states between the planar and focal-conic states. FIGURE 2 illustrates a schematic representation of a CLC domain in a predominantly planar state. In the planar state, the CLC molecules are arranged in hypothetical layers with the long axes of the molecules in each layer substantially parallel to each other (and the display substrates); the director of the domains thus being substantially perpendicular to the layers. The periodicity of the planar state selectively reflects electromagnetic radiation (*e.g.* ambient light) that is perpendicularly incident on these layers. The center wavelength of the selective radiation band is given by $\lambda = np$, where λ is the wavelength of the radiation, n is the average refractive index of liquid crystal and p is the predetermined pitch of the CLC material. In the planar state, the CLC exhibits a bright state having an intrinsic color having a wavelength substantially equal to λ , which can be changed by varying the amount of chiral material in the CLC.

Turning now to FIGURE 3, illustrated is a schematic representation of a CLC domain in a predominantly focal-conic state. In the focal-conic state, the director of each CLC domain is substantially parallel to the display substrates and randomly oriented with respect to the directors of other CLC domains. The randomly-oriented directors causes a scattering of all wavelengths of the incident light. If the thickness of the CLC is thin enough (*e.g.*, less than 5 μm), only a very small percentage of the incident radiation is reflected, or “back-scattered;” the remainder being transmitted, or “forward-scattered.” If the CLC panel includes a back plate that absorbs the transmitted radiation, then the portion of the

panel in the focal-conic state will appear substantially “black” to an observer.

Turning now to FIGURE 4, illustrated is a schematic representation of a CLC domain in an intermediate (“gray scale”) state
5 between a predominantly planar state and a predominantly focal-conic state. Because the director of each local domain in a display pixel may not be substantially perpendicular or parallel to the display substrates, as described *supra* for the predominantly planar and focal-conic states, respectively, each pixel can be driven to a state that exhibits a light-
10 reflectivity level intermediate between the predominantly planar and predominantly focal-conic states; the average angle of the directors of the local domains, relative to the display substrates, determining the light-reflection intensity (*i.e.* intermediate state) of the CLC pixel. For example, if a substantial portion of the local domains are in the planar
15 state, the pixel appearance will correspond to one extreme of the gray scale; if a substantial portion of the local domains are in the focal-conic state, the pixel appearance will correspond to the other extreme of the gray scale; each intermediate gray scale level corresponding to a relative proportion of local domains having a particular average angle.

20 Another important structure of CLCs is the “field induced” nematic phase. FIGURE 5 illustrates a schematic representation of a CLC in a field-induced nematic phase. “Field induced” means that the a driving signal must be continually applied to the CLC to maintain the nematic phase; thus, the nematic phase is not a stable state. If a strong
25 electric field is applied to the CLC, the CLC transitions to a nematic phase, regardless of whether the initial state of the CLC was the planar or focal-conic state. When the strong electric field is removed, the CLC will reform to a cholesteric phase planar or focal-conic. If the electric field is removed relatively fast, the CLC will transition to the light-reflective

planar state. If the electric field is not reduced to zero immediately (*e.g.*, the strong electric field is followed by a lower electric field), however, the CLC will transition to the light-scattering focal-conic state.

Turning now to FIGURE 6, illustrated is an exemplary electro-optical response characteristic of a CLC. The experimental data illustrated in FIGURE 6 confirm the existence of zero-field stable states of a conventional CLC driven to various levels of reflectivity by a single voltage pulse having a fixed duration; the reflectivity of the CLC plotted as a function of the magnitude of the voltage pulse employed. The reflection measurements were made under zero-field conditions; *i.e.* the measurements were taken after the driving pulse was removed. The scale of reflectivity illustrated is an arbitrary scale of reflectance values normalized to a maximum level of reflectivity. The solid circles represent the reflectivity of the CLC, following application of various driving pulses having voltages as shown, for a CLC initially in a predominantly light-reflecting planar state; *i.e.* initial reflectivity equal to approximately 1. The empty circles represent the reflectivity of the CLC, following application of various driving pulses having voltages as shown, for a CLC initially in a predominantly light-scattering state; *i.e.* initial reflectivity equal to approximately .12 .

As the data reveal for a CLC initially in the predominantly planar state, there is an apparent threshold voltage (V_t); if the pulse voltage is below the threshold, the state (reflectivity) of the CLC is unchanged by the pulse. At pulse voltages above the threshold, however, the state of the CLC is progressively changed to a more light-scattering, and less light-reflective, state, as shown by the decrease in reflectivity with increasing pulse voltage. At a pulse voltage equal to V_t , the CLC transitions to a nematic phase and then relaxes to a light-reflective planar state when the pulse is removed. Thus, the pulse voltage V_t is the

maximum voltage at which a zero-field stable reflective (planar) state is realized; *i.e.* voltages above V_r drive the CLC into the unstable nematic phase.

With continuing reference to FIGURE 6, the voltage V_c is defined
5 as the critical phase change voltage; for pulse voltages between V_c and V_r , a phase change from the cholesteric phase to the nematic phase is partially induced in the CLC domains. Also, the voltage V_s is used to describe the driving voltage necessary to drive a CLC initially in the light-reflecting planar state to the light-scattering focal-conic state; the value of V_s being
10 intermediate between V_l and V_c . Experimental data reveal that, for a particular CLC, the values of V_l , V_s , V_c , and V_r are a function of the width of the driving pulse applied; in general, the values increase with decreasing pulse widths.

Those skilled in the art will recognize from the data illustrated in
15 FIGURE 6 that the CLC can be driven between a light-reflective planar and a light-scattering focal-conic state by applying a pulse having an appropriate amplitude, and *vice versa*. It has been observed, however, that the time required to drive a CLC from a focal-conic state to a planar state is quite different from the time required to change from a planar
20 state to a focal-conic; the former possibly requiring tens of microseconds, while the latter is in the order of milliseconds.

It has been observed that the predominantly planar state (*i.e.* reflectivity approximately equal to "1") of a CLC can only be achieved by applying a high-voltage at or above the voltage V_r , which
25 homeotropically aligns the CLC in a field-induced nematic phase, and then quickly removing the applied voltage. If the CLC is initially in a predominantly planar state P, an applied electrical field can convert the CLC into a predominantly focal-conic state F by a pulse voltage slightly below the critical phase change voltage V_c , provided that the pulse

duration is sufficiently long. Alternatively, a CLC can be transitioned to a predominantly focal-conic state F by applying a high-voltage at or above the voltage V_r , which homeotropically aligns the CLC in a field-induced nematic phase, and then applying a lower-voltage pulse or gradually reducing the pulse voltage to force the liquid crystal to transition to a predominantly focal-conic state. The present invention recognizes that it takes less time to switch to a predominantly focal-conic state by driving the CLC with a high-voltage pulse into the field-induced nematic phase and then applying a lower-voltage pulse, than by driving the CLC with a sufficiently-long duration pulse having a voltage slightly below the critical phase change voltage V_c . An additional advantage of this method is that, by first driving a CLC into the nematic phase, the predominantly focal-conic state realized always has the same low reflectivity (*i.e.* substantially "black"). In contrast, the reflectivity of the resulting focal-conic state arrived at by other driving methods is sensitive to the thickness of the CLC employed, the pulse voltage and the pulse duration. The sensitivity of the electro-optical response characteristic of a CLC to variations in pulse duration can be described with reference to FIGURE 7.

Turning now to FIGURE 7, illustrated are exemplary electro-optical response characteristics of a CLC for driving pulses of different durations; FIGURE 7-a illustrating the response characteristic for a driving pulse having a pulse duration of 50 ms; FIGURE 7-B illustrating the response characteristic for a driving pulse having a pulse duration of 3 ms; FIGURE 7-C illustrating the response characteristic for a driving pulse having a pulse duration of 1 ms; and FIGURE 7-D illustrating the response characteristic for a driving pulse having a pulse duration of 70 μ s.. The reflectivity measurements in FIGURES 7-A, 7-B, 7-C, and 7-D were made under zero-field conditions. The solid circles represent the

reflectivity of the CLC, following application of various driving pulses having voltages as shown, for a CLC initially in a predominantly light-reflecting planar state; *i.e.* initial reflectivity equal to approximately 1. The empty circles represent the reflectivity of the CLC, following application of various driving pulses having voltages as shown, for a CLC initially in a predominantly light-scattering state; *i.e.* initial reflectivity equal to approximately .18 . The initial focal-conic state was obtained by applying a high-voltage pulse followed by a lower-voltage pulse; the CLC changing its phase to a field-induced nematic phase in response to the high-voltage pulse and then reforming to a cholesteric-phase focal-conic state in response to the lower-voltage pulse.

It can be noted in FIGURES 7-B, C, and D that, in each case, the lowest point of reflectivity R_L for the electro-optical response of a CLC initially in the predominantly planar state (shown by solid circles) exceeds the reflectivity level of the predominantly focal-conic state (represented by the lower plateau of the curve marked by the empty circles). Thus, an important observation can be made from FIGURES 7-A, B, C, and D: if the CLC is initially in a predominantly light-reflective planar state P, it can only be switched to a predominantly light-scattering focal-conic state F (without first driving the CLC to the nematic phase) with a wide driving pulse (*e.g.* 50 ms), as shown in FIGURE 7-A; *i.e.* the CLC can not be directly driven from the planar state P to the focal-conic state F with relatively short duration pulses (FIGURES 7-B, C, and D).

Predicated in part by the heretofore-described observations of the effect of various driving-pulse voltages and durations on the electro-optical response of a CLC, the present invention discloses a novel apparatus for and method of driving a CLC flat panel display by which it is possible to drive a CLC at sufficiently-fast frame rates necessary for full-motion video applications. The disclosed method, employing a two-

stage driving scheme, takes advantage of the rapid transition of a CLC from a light-scattering focal-conic state to a light-reflective planar state. The two-stage driving scheme includes an "initialization" and an "addressing" stage.

5 Turning now to FIGURE 8, illustrated are exemplary waveforms and an exemplary timing sequence for a CLC driving method according to the principles of the present invention. The first stage of the disclosed method is the initialization stage 800 in which the pixels of the CLC display are selectively driven to a focal-conic state; the second, or
10 "addressing," stage consisting of selectively driving the CLC pixels to a desired display state. The desired display state of each pixel can be a predominantly light-scattering focal-conic state (*i.e.* the initial state following the initialization stage), a predominantly light-reflecting planar state, or any intermediate state between the predominantly light-scattering
15 focal-conic and predominantly light-reflecting planar states. In the initialization stage, two sequences of pulses are selectively applied to pixels of the CLC; a pixel being driven into the nematic phase by a first sequence of high-amplitude pulses 810, which are followed by a second sequence of low-amplitude pulses 820, which cause the pixel's CLC
20 domains to transition from the nematic phase to a predominantly focal-conic state. Following the initialization sequence, the selected pixel is in a light-scattering state (regardless of the initial state of the pixel), which has a substantially "black" appearance. The purpose of the initialization stage is to erase the previous state "memorized" in the pixel and prepare
25 the pixel for a new state in the addressing stage.

 Turning now to FIGURES 9-A and 9-B, illustrated are an exemplary first pulse sequence 910 and an exemplary second pulse sequence 920 of an initialization waveform for a CLC driving apparatus and method according to the principles of the present invention. In one

embodiment, the frequency of the pulses is selected to be 14.3 kHz; the first sequence of pulses 910 having an amplitude of 50 volts and a duration of 2 ms (FIGURE 9-A); the second sequence of pulses 920 having an amplitude of 18 volts and a duration of 4 ms (FIGURE 9-B);
5 the specific pulse amplitudes and durations required for a CLC are a function of the electro-optical response of each particular embodiment, defined in part by the CLC material and thickness employed.

The initialization stage is very important to realize a CLC display capable of operating at full-motion video frame rates. For a CLC display
10 having a matrix of pixels, the state of each pixel should be switched as quickly as possible. Thus, as described *supra*, the relatively-slow speed (in the order of milliseconds) at which a CLC can be switched from a predominantly light-reflective planar state to a predominantly light-scattering focal-conic state should be avoided. This is accomplished by
15 only employing, in the addressing stage, the relatively-fast speed (in the order of tens of microseconds) at which a CLC can be switched from a predominantly light-scattering focal-conic state to light-reflective planar and intermediate states. Thus, to only employ state transitions from a focal-conic state to a planar or intermediate state during the addressing
20 stage, it is necessary to drive each pixel to a predominantly focal-conic state during an initialization stage; a predominantly focal-conic state providing a reference state from which each pixel can be driven very quickly to any desired state during the addressing stage. Although the initialization stage may require milliseconds to perform, every pixel in a
25 display, or in selected rows, can be initialized at the same time. Because the display pixels can only be addressed by rows, as hereinafter described, the display frame rate is primarily affected by the time required for addressing. The novel driving method disclosed herein minimizes the time required for addressing, thereby maximizing a CLCs frame rate.

Two specific embodiments for employing the driving methods disclosed by the present invention are the "frame initialization" and the "multi-row initialization" techniques. The frame initialization technique disclosed herein employs polar drive signals, selectively applied to

5 column and row electrodes. In the frame initialization technique, every display pixel is first initialized to a predominantly focal-conic state. FIGURE 10 illustrates exemplary column and row initialization signals for a frame initialization CLC driving technique. All pixels are driven to a predominantly focal-conic state by two consecutive pulse sequences.

10 The signals illustrated in the first row and first column of FIGURE 10 are polar pulses, which are applied simultaneously to the row and column electrodes. The resulting electric field waveforms applied on each pixel (shown in the center section of FIGURE 10) are a combination of the signals applied on the corresponding row and column electrodes.

15 Although the input signal to each row and column electrode is polar, the combined waveforms acting on each pixel are bi-polar; thus, DC signal components, which can ionize a CLC and thereby reduce the life of the cell, are eliminated.

Turning now to FIGURE 11, illustrated are exemplary column and

20 row polar addressing signals for a frame initialization CLC driving method according to the principles of the present invention. The signals illustrated in the first row and first column of FIGURE 11 are polar pulses, which are applied simultaneously to the row and column electrodes. The resulting electric field waveforms applied on each pixel

25 (shown in the center section of FIGURE 11) are a combination of the signals applied on the corresponding row and column electrodes. Although the input signal to each row and column electrode is polar, the combined waveforms acting on each pixel are bi-polar; thereby avoiding the undesirable effect of DC signal components, as described *supra*.

In order to drive a LC matrix display using a passive driving method, those skilled in the art will understand that it is important to recognize that an addressing signal applied to a column electrode will influence the electrical field appearing across every pixel in that column; the CLC threshold voltage V_t (reference FIGURE 6, described *supra*) being a limiting factor for the signals employed. Furthermore, the addressing signals must optimize the switching (*i.e.* state transition) of selected pixels over non-selected pixels. Thus, to eliminate the crosstalk generally associated with passive-matrix LC driving methods, the voltage of the applied pulse on the pixels in each non-selected row must be below the threshold voltage V_t . For a selected row, a higher-voltage pulse having an amplitude V_r should be applied to the pixels for which a state change is desired, while a lower-voltage pulse having an amplitude V_s should be applied to the pixels for which a state change is not desired.

The addressing method may preferably use the conventional practice of selectively applying "data" signals to column electrodes and "scan" signals to row electrodes; as used herein, both "data" signals and "scan" signals are components of "addressing" signals. A CLC display frame can be completely addressed by sequentially activating each row of pixels with a scan signal 1103 while selectively applying data signals 1101, 1102 for each pixel in a selected row to the column electrodes; the pixels in a row being driven by a combined bi-polar pulse 1105/1106 having an amplitude of V_r or V_s during addressing of the selected row. If the state of a pixel is to be changed, the data signal applied to the column containing the pixel has an amplitude of V_r ; otherwise, the data signal has an amplitude of V_s .

In order to maintain the states of all pixels in non-selected rows, the following formula should be satisfied to determine an appropriate driving pulse 1104 for non-selected rows:

$$V_n = \frac{V_r - V_s}{2} < V_t$$

From this requirement, it is clear that the voltage V_r is limited by: $V_r < 2 V_t + V_s$. For an appropriate driving pulse 1104 having an amplitude V_n , the state of a pixel in a non-selected row will not be changed, regardless of whether column driving signal 1101 or 1102 is applied to the pixel's column electrode.

The general approach to driving a passive-matrix CLC display using the frame initialization driving technique can be summarized as: frame initialization and row-to-row addressing. All pixels in a frame are simultaneously initialized to a predominantly focal-conic state by two pulse sequences as described with reference to FIGURES 8-10. During the initialization stage, all of the rows in a frame are selected, and each pixel is driven by a first sequence of pulses to change from a cholesteric phase to a field-induced nematic phase; a second sequence of pulses driving each pixel to a cholesteric-phase predominantly focal-conic state. To initialize a total frame may only require several milliseconds. In the addressing stage, an addressing signal 1103 (FIGURE 11) having an amplitude V_r is applied to the row electrode for the selected row. Depending on the desired state of each pixel in the selected row, the signal applied to the column electrodes are either an "ON" waveform 1101 or "OFF" waveform 1102 as shown in FIGURE 11. Each pixel in a selected row is driven by the combination of signals applied to the row and column electrodes. A non-selected row driving signal 1104 is applied to each row other than the row currently being addressed. The amplitude of the combined bi-polar pulses applied to each pixel in a non-selected row is always below the threshold voltage V_t , and thus there is no effect on the state of the pixels in a non-selected row. The stability of the CLC cholesteric phase maintains the image on the display until initialization of

the next frame. In some applications, an idle period may be required between frame initializations to improve the contrast ratio of the display. The time between each frame initialization is the frame driving time; the reciprocal of the driving time is the frame rate.

5 The frame initialization technique described above may be suitable for certain applications, but a disadvantage of the technique, however, is that (except for the first row of pixels in a frame) the addressing of each pixel can not be performed immediately following the initialization of the pixel. Moreover, since the pixels in a frame are initialized at the same
10 time but addressed at different times, the static display time of each pixel will be different. A second embodiment for employing the driving methods disclosed by the present invention is the “multi-row initialization” technique, which uses bi-polar driving signals to overcome the disadvantages of the frame initialization technique.

15 FIGURE 12 illustrates exemplary column and row initialization and addressing signals for a multi-row initialization CLC driving technique. Similar to FIGURES 10 and 11, FIGURE 12 illustrates the driving signals applied to row and column electrodes. All of the signals, however, are symmetric bi-polar, rather than polar, waveforms. Using
20 the multi-row addressing technique, high-voltage bi-polar signals are applied to the row electrodes and low-voltage bi-polar signals are applied to the column electrodes.

 The first row of FIGURE 12 illustrates exemplary waveforms 1201, 1202 for column electrode addressing signals corresponding to
25 “ON” and “OFF” states. The waveform 1203 illustrates an exemplary addressing pulse that is applied to the row electrode of a selected row of pixels. The waveform 1204 illustrates the combined pulse applied to a pixel in the selected row that is to be driven to the “ON” state; the waveform 1205 illustrates the combined pulse applied to a pixel that is

to be maintained in the predominantly focal-conic (“OFF”) state. In order to drive a pixel “OFF”, or “ON”, the addressing signal applied to a row electrode for a selected row must be in phase or out of phase, respectively, with the addressing signal applied to a pixel’s column electrode. The “waveform” 1206 is a zero voltage applied to the row electrode of each non-selected row. The waveforms 1207, 1208 illustrate the combined pulses applied to each pixel in a non-selected row. Because the amplitude of the pulses 1207, 1208 are below the CLC threshold voltage V_t , the pulses will not affect the state of the pixels.

10 In accordance with the principles of the present invention, each pixel must be initialized prior to being addressed. The waveforms 1209, 1210 in FIGURE 12 illustrate a first and second sequence of signals (described *supra*), respectively, that are applied to the row electrodes of each row of pixels that is to be initialized. The waveforms 1211, 1212 and 1213, 1214 illustrate the combined signals applied to each pixel during the first and second sequence of initialization signals, respectively. The voltages V and V_1 for the row initialization signals 1209, 1210 are selected such that the amplitudes of the first and second sequence of combined initialization signals drive each pixel to a nematic phase and, subsequently, to a predominantly focal-conic state, as described *supra*.

20 The frequency of the signals 1201, 1202 applied to the column electrodes preferably have the same frequency as the addressing signals 1203, 1206 that are applied to the row electrodes. The frequency of the signals 1209, 1210 for the initialization stage, denoted as f_i , and the frequency of the addressing signals 1203, 1206, denoted as f_a , however, can be different, provided the following relationship is satisfied:

$$f_a = Nf_i,$$

25 where N is a positive integer. The signals illustrated in FIGURE 12 are for the case where N is equal to 1. When $N=1$, the phase difference

between the initialization signals 1209, 1210 applied to the row electrodes and the signals 1201, 1202 applied to the column electrodes must equal 90°. Using the combined signal waveforms 1204, 1205, 1207, 1208, 1211-1214 illustrated in FIGURE 12, the present invention recognizes that four different signals can be applied simultaneously to four different rows of a CLC display, without any crosstalk. One, or more, rows can be initialized at the same time that another row is being addressed. Thus, the addressing stage for every row can immediately follow the initialization stage for that row. An advantage of the bi-polar multi-row initialization technique is that every pixel can have the same “dynamic” and “static” display times. The dynamic display time is defined as the time during which the pixel is being driven by an electrical field, and the static display time is defined as the time during which the pixel is not being driven; *i.e.* the pixel is in a stable cholesteric phase.

Referring again to FIGURE 6, those skilled in the art will recognize that a CLC can be driven from a light-reflective planar to a light-scattering focal-conic state by applying a pulse having an appropriate amplitude, and *vice versa*. As noted *supra*, United States Patent No. 5,453,863, issued to West, *et al.* on September 26, 1995, discloses the use of signals of varying electrical magnitudes to transform the CLC from focal-conic to planar states, and *vice versa*; a continuum of signal magnitudes being used to drive the CLC to intermediate “gray scale” states. The portion of a typical CLC electro-optical response curve corresponding to the intermediate (*i.e.* gray scale) states has a steep slope; *i.e.* the portion of the curve corresponds to a narrow voltage range over which signals of varying electrical magnitudes can be used to drive a CLC to different intermediate states. Because the voltage range is typically narrow, a principal disadvantage of the method disclosed by West, *et al.* is that it is difficult to precisely drive the CLC to a preferred intermediate

state. Furthermore, the electro-optical response curve of a CLC will shift to the left or right with variations in the cell gap (*i.e.* the thickness of the CLC). Because the portion of a typical CLC electro-optical response curve corresponding to the intermediate (*i.e.* gray scale) states has a steep slope, even a slight shift in the curve will cause a particular drive voltage to produce different intermediate states in pixels having slightly different cell gaps. The present invention recognizes that a gray scale CLC display can be realized by applying a single pulse, or sequence of pulses, having a fixed predetermined amplitude; each successive pulse causing a progressive change in the state of the CLC. Thus, the method disclosed herein for driving a CLC display does not rely on the use of signals of varying electrical magnitudes to realize a gray scale display, but employs pulses having a fixed predetermined amplitude whereby each gray scale level (*i.e.* intermediate state) is a function of a duration of the pulses.

According to the two-stage driving techniques disclosed herein, each pixel is first initialized to a predominantly focal-conic state. In response to an address pulse, or sequence of address pulses, a progressive change from the predominantly focal-conic state to the predominantly planar state can be obtained. Moreover, it has been observed that each intermediate, or gray scale, state is perfectly stable under zero-field conditions. Furthermore, a benefit of employing a single address pulse, or sequence of address pulses, having a fixed predetermined amplitude is that the gray scale states can be precisely controlled.

To employ the pulse-sequence addressing technique to full advantage, those skilled in the art will recognize that it is important to equalize the addressing-stage driving time for each pixel in a selected row. Because the technique requires either a single pulse or a sequence of pulses to drive a pixel from a predominantly focal-conic state to a predominantly planar state, and states therebetween, the minimum time

to address each pixel is a function of the desired state. Thus, to compensate for the different times required to change a pixel from an initial state to a desired state, a sequence of pulses having an amplitude which has no effect on a pixel's state can be applied ahead of a sequence
5 of pulses having an amplitude sufficient to cause a change in state.

FIGURE 13 illustrate an exemplary addressing waveform pulse sequence for a gray-scale CLC driving apparatus and method according to the principles of the present invention. The duration of the two pulse sequences 1301, 1302 is equal to a predetermined addressing time T ,
10 which is equal to or greater than the time necessary to drive a pixel from a predominantly focal-conic state to a predominantly planar state; if the desired pixel state is intermediate these states, a sequence of pulses 1302 having an amplitude which has no effect on the pixel's state is applied ahead of the sequence of pulses 1301 having an amplitude sufficient to
15 cause a change in state. T_1 is the duration of the lower-voltage pulse sequence and T_2 is the duration of the higher-voltage pulse sequence; those skilled in the art will recognize that the order of applying pulse sequences 1301, 1302 may be reversed.

The gray scale state of each pixel is determined by the ratio of the
20 duration T_2 of the sequence of pulses 1301 to the predetermined addressing time T . The amplitude of the sequence of pulses (or single pulse) 1301 is equal to the phase change voltage V_r , for the specific CLC employed, that corresponds to a single addressing pulse having a pulse width of T ; *i.e.* if a pulse of duration T and amplitude V_r is applied to the
25 CLC, the CLC will transition to the nematic phase. The number of distinct gray scale states is determined by the frequency of the address pulses; *e.g.* if eight pulses can occur during time T , then an eight-level gray scale for each pixel can be realized.

Turning now to FIGURE 14, illustrated is an exemplary electro-optical response characteristic of a CLC for addressing waveform pulse sequences of different pulse sequence durations T_2 ; the reflectivity of a single cell, measured under zero-field conditions, being plotted as a function of the ratio of T_2 to T . Those skilled in the art will observe the wide linear region which can be employed to advantage to realize a gray scale CLC display. Because the reflectivity is a function of the ratio of T_2 to T , which can be accurately controlled, the method disclosed herein does not suffer from the disadvantages associated with using a magnitude of the driving signal to control the reflectivity, as disclosed by West, *et al.* (described hereinabove). Furthermore, even though the curve illustrated in FIGURE 14 may shift to the left or right as a function of the CLC cell gap, those skilled in the art will recognize that, because of the wide linear region, a slight shift in the curve will only have a negligible effect on the resulting cell reflectivity.

Turning now to FIGURE 15, illustrated is an exemplary apparatus for employing the above-described method for driving a CLC display according to the principles of the present invention. FIGURE 15 illustrates a driving apparatus 1510 coupled to a CLC panel 1540. In one embodiment, the CLC panel 1540 includes a plurality of controllable display elements 1545-1, 1545-2, 1545-3, 1545-n (*e.g.* pixels) defined by a matrix of row and column electrodes (not shown). The driving apparatus includes a data circuit 1520 that is coupled to the column electrodes and a scan circuit 1530 that is coupled to the row electrodes of CLC panel 1540. The data circuit 1520 and scan circuit 1530 selectively apply the initialization and addressing signals disclosed hereinabove to the CLC panel 1540, the signals applied to the column electrodes cooperating with the signals applied to the row electrodes to selectively drive each controllable display element 1545 from a predominantly focal-conic state

to a predominantly planar state, and intermediate states therebetween. The principles of the present invention are not limited to a particular embodiment of the driving apparatus 1510, except to the extent that data circuit 1520 and scan circuit 1530 must be suitably operative to generate
5 initialization and addressing signals in accordance with the principles of the present invention.

Those of skill in the art understand the effect of ambient temperature on the performance of CLC displays; particularly at relatively-low temperatures. The response of a CLC to an applied voltage
10 is directly related to the viscosity of the CLC material; the viscosity generally rising exponentially with decreasing temperature, which results in a corresponding increase in the response time of the CLC. At a particular temperature, the viscosity of the CLC material is related to the material's structure. Thus, the synthesization of low-viscosity CLC
15 materials is one approach to avoid slower response times at low temperatures; however, only slight improvements in CLC viscosity at low temperatures can be anticipated. A second approach to overcome the problem of low viscosity at low temperatures is to compensate for the change in viscosity by altering the driving waveforms applied to the CLC.

20 Turning now to FIGURE 16-A, illustrated is the effect of temperature on the phase change voltage V_r of an exemplary CLC, for a driving time of 5 ms. As can be seen, the phase change voltage V_r increases with decreasing temperature. Referring to FIGURE 16-B, which illustrates the effect of temperature on the required driving time for
25 an applied voltage of 40 volts, it can be seen that the driving time rises exponentially with decreasing temperature. Thus, in order to realize full-motion video frame rates at low temperatures; employing the driving methods disclosed hereinabove, the effects of temperature on display driving time can be compensated for by increasing the driving voltage.

A feedback mechanism, which senses the temperature of the CLC display, can be employed to provide a temperature compensation signal to the driving apparatus, which can appropriately increase, or decrease, the amplitude of the initialization and addressing signals; alternatively,
5 although less desirable for most applications, the driving apparatus can appropriately increase, or decrease, the duration of the driving signals to compensate for variations in display temperature.

Although the present invention and its advantages have been described in detail, those skilled in the art should understand that they can
10 make various changes, substitutions and alterations herein without departing from the spirit and scope of the invention in its broadest form.

WE CLAIM:

1. A method of driving at least a portion of a cholesteric liquid crystal (CLC) panel to a state having a given reflectivity, comprising the steps of:

initially driving said portion to a nematic phase;

subsequently driving said portion to a cholesteric phase focal-conic state, said cholesteric phase focal-conic state providing a known reference state for subsequent driving of said portion; and

thereafter driving said portion to said state having said given reflectivity.

2. The method of driving as recited in Claim 1 wherein said step of initially driving comprises the step of applying a sequence of pulses to drive said portion to said nematic phase.

3. The method of driving as recited in Claim 1 wherein said step of subsequently driving comprises the step of applying a sequence of pulses to drive said portion to said cholesteric phase focal-conic state.

4. The method of driving as recited in Claim 1 wherein said step of initially driving comprises the step of applying a first sequence of pulses having a first amplitude to drive said portion to said nematic phase and said step of subsequently driving comprises the step of applying a second sequence of pulses having a second amplitude to drive said portion to said cholesteric phase focal-conic state.

5. The method of driving as recited in Claim 4 wherein said
2 first and second amplitudes are a function of a composition of CLC in
3 said CLC panel.

6. The method of driving as recited in Claim 4 wherein said
2 first and second amplitudes are a function of a thickness of said CLC
3 panel.

7. The method of driving as recited in Claim 1 wherein said
2 step of thereafter driving comprises the step of applying a sequence of
3 pulses to drive said portion from said cholesteric phase focal-conic state
4 to said state having said given reflectivity.

8. The method of driving as recited in Claim 1 wherein said
2 state having said given reflectivity is an intermediate state between said
3 cholesteric phase focal-conic state and a cholesteric phase planar state,
4 and wherein said step of thereafter driving said portion to said
5 intermediate state comprises the step of applying a sequence of addressing
6 pulses having a predetermined amplitude to drive said portion from said
7 cholesteric phase focal-conic state to said intermediate state, said given
8 reflectivity being a function of a duration of said sequence of addressing
9 pulses.

2 9. The method of driving as recited in Claim 8 wherein said
3 step of applying a sequence of addressing pulses having a predetermined
4 amplitude is preceded by the step of applying a first sequence of pulses
5 having an amplitude less than a minimum amplitude necessary to drive the
6 CLC from the focal-conic state, a duration of said first sequence of pulses
7 adjusted such that the sum of said duration of said first sequence of pulses
8 and said duration of said sequence of addressing pulses equals a
9 predetermined value.

2 10. A driving apparatus for a cholesteric liquid crystal (CLC)
3 panel, said driving apparatus comprising:
4 a data circuit, couplable to said CLC panel, that selectively applies
5 a first initialization signal and a first addressing signal to said CLC panel;
6 and
7 a scan circuit, couplable to said CLC panel, that selectively applies
8 a second initialization signal and a second addressing signal to said CLC
9 panel, said first and second initialization signals cooperating to drive a
10 CLC in said CLC panel into a nematic phase and subsequently to drive
11 said CLC to a cholesteric phase focal-conic state, said first and second
12 addressing signals cooperating to selectively drive said CLC from said
13 cholesteric phase focal-conic state to a state having a given reflectivity.

2 11. The driving apparatus as recited in Claim 10 wherein each
3 of said first and second initialization signals comprises a first sequence of
4 pulses having a first amplitude and a second sequence of pulses having a
5 second amplitude, said first sequence of pulses driving said CLC into said
6 nematic phase and said second sequence of pulses driving said CLC to
7 said cholesteric phase focal-conic state.

12. The driving apparatus as recited in Claim 11 wherein said
2 first amplitude and second amplitudes are a function of a composition and
3 thickness of said CLC.

13. The driving apparatus as recited in Claim 11 wherein said
2 first and second sequence of pulses have a frequency of about 14.3 kHz.

14. The driving apparatus as recited in Claim 11 wherein said
2 first sequence of pulses has a duration of about 2 ms and said second
3 sequence of pulses has a duration of about 4 ms.

15. The driving apparatus as recited in Claim 10 wherein each
2 of said first and second addressing signals comprises a sequence of
3 addressing pulses having a predetermined amplitude, said driving
4 apparatus operative to drive said CLC to said state having said given
5 reflectivity by varying a duration of said sequence of addressing pulses.

16. The driving apparatus as recited in Claim 15 wherein said
2 predetermined amplitude is a function of a composition and thickness of
3 said CLC.

17. The driving apparatus as recited in Claim 15 wherein said
2 first and second sequence of pulses have a frequency of about 14.3 kHz.

18. The driving apparatus as recited in Claim 15 wherein said
2 sequence of addressing pulses having a predetermined amplitude is
3 preceded by a first sequence of pulses having an amplitude less than a
4 minimum amplitude necessary to drive said CLC from the focal-conic
5 state, a duration of said first sequence of pulses varied such that the sum
6 of the duration of the first sequence of pulses and the duration of the
7 sequence of addressing pulses has a constant value.

19. The driving apparatus as recited in Claim 10 wherein said
2 first and second initialization signals and said first and second addressing
3 signals comprise bipolar electrical waveforms.
4

20. A driving apparatus for a cholesteric liquid crystal (CLC)
2 panel having first and second electrodes coupled to opposing sides
3 thereof, said driving apparatus comprising:

4 a data circuit couplable to said first electrode for selectively
5 applying a first initialization signal and a first addressing signal to said
6 CLC panel; and

7 a scan circuit couplable to said second electrode for selectively
8 applying a second initialization signal and a second addressing signal to
9 said CLC panel, said first and second initialization signals cooperating to
10 drive a CLC in said CLC panel into a nematic phase and subsequently to
11 drive said CLC to a cholesteric phase focal-conic state, said first and
12 second addressing signals cooperating to selectively drive said CLC from
13 said cholesteric phase focal-conic state to a state having a given
reflectivity.

2 21. The driving apparatus as recited in Claim 20 wherein each
3 of said first and second initialization signals comprises a first sequence of
4 pulses having a first amplitude and a second sequence of pulses having a
5 second amplitude, said first sequence of pulses driving said CLC into said
6 nematic phase and said second sequence of pulses driving said CLC to
7 said cholesteric phase focal-conic state.

 22. The driving apparatus as recited in Claim 21 wherein said
2 first and second amplitudes are a function of a composition and thickness
3 of said CLC.

 23. The driving apparatus as recited in Claim 21 wherein said
2 first and second sequence of pulses have a frequency of about 14.3 kHz.

 24. The driving apparatus as recited in Claim 21 wherein said
2 first sequence of pulses has a duration of about 2 ms and said second
3 sequence of pulses has a duration of about 4 ms.

 25. The driving apparatus as recited in Claim 20 wherein each
2 of said first and second addressing signals comprises a sequence of
3 addressing pulses having a predetermined amplitude, said driving
4 apparatus operative to drive said CLC to said state having said given
5 reflectivity by varying a duration of said sequence of addressing pulses.

 26. The driving apparatus as recited in Claim 25 wherein said
2 predetermined amplitude is a function of a composition and thickness of
3 said CLC.

27. The driving apparatus as recited in Claim 25 wherein said
2 first and second sequence of pulses have a frequency of about 14.3 kHz.

28. The driving apparatus as recited in Claim 25 wherein said
2 sequence of addressing pulses having a predetermined amplitude is
3 preceded by a first sequence of pulses having an amplitude less than a
4 minimum amplitude necessary to drive said CLC from the focal-conic
5 state, a duration of said first sequence of pulses varied such that the sum
6 of the duration of the first sequence of pulses and the duration of the
7 sequence of addressing pulses has a constant value.

29. The driving apparatus as recited in Claim 20 wherein said
2 first and second initialization signals and said first and second addressing
3 signals comprise bipolar electrical waveforms.

2 30. A driving apparatus for a cholesteric liquid crystal (CLC)
3 display having a plurality of controllable display elements, said CLC
4 display having a matrix of row and column electrodes that define each of
5 said controllable display elements, said driving apparatus comprising:

6 a data circuit couplable to said column electrodes for selectively
7 applying a first initialization signal and a first addressing signal to each
8 of said display elements; and

9 a scan circuit couplable to said row electrodes for selectively
10 applying a second initialization signal and a second addressing signal to
11 each of said display elements, said first and second initialization signals
12 cooperating to drive said controllable display elements into a nematic
13 phase and subsequently to drive said controllable display elements to a
14 cholesteric phase focal-conic state, said first and second addressing signals
15 cooperating to selectively drive said controllable display elements from
16 said cholesteric phase focal-conic state to a state having a given
 reflectivity.

 31. The driving apparatus as recited in Claim 30 wherein each
2 of said first and second initialization signals comprises a first sequence of
3 pulses having a first amplitude and a second sequence of pulses having a
4 second amplitude, said first sequence of pulses driving selected ones of
5 said controllable display elements into said nematic phase and said second
6 sequence of pulses driving said selected ones of said controllable display
7 elements to said cholesteric phase focal-conic state.

 32. The driving apparatus as recited in Claim 31 wherein said
2 first and second amplitudes are a function of a composition and thickness
3 of said CLC.

2 33. The driving apparatus as recited in Claim 31 wherein said
first and second sequence of pulses have a frequency of about 14.3 kHz.

2 34. The driving apparatus as recited in Claim 31 wherein said
first sequence of pulses has a duration of about 2 ms and said second
3 sequence of pulses has a duration of about 4 ms.

2 35. The driving apparatus as recited in Claim 30 wherein said
first and second addressing signals comprise a sequence of addressing
3 pulses having first and second predetermined amplitudes, respectively,
4 said driving apparatus operative to drive said CLC to said state having
5 said given reflectivity by varying a duration of said sequence of
6 addressing pulses.

2 36. The driving apparatus as recited in Claim 35 wherein said
first and second predetermined amplitudes are a function of a composition
3 and thickness of said CLC.

2 37. The driving apparatus as recited in Claim 35 wherein said
first and second sequence of pulses have a frequency of about 14.3 kHz.

2 38. The driving apparatus as recited in Claim 35 wherein said
sequence of addressing pulses is preceded by a first sequence of pulses
3 having an amplitude less than a minimum amplitude necessary to drive
4 said CLC from the focal-conic state, a duration of said first sequence of
5 pulses varied such that the sum of the duration of the first sequence of
6 pulses and the duration of the sequence of addressing pulses has a constant
7 value.

2 39. The driving apparatus as recited in Claim 30 wherein said
3 first and second initialization signals are applied simultaneously to each
 of said plurality of controllable display elements.

2 40. The driving apparatus as recited in Claim 30 wherein said
3 first and second initialization signals are applied to at least a first selected
4 row of said plurality of controllable display elements, said first and
5 second addressing signals being applied simultaneously therewith to at
6 least a second selected row of said plurality of controllable display
 elements.

2 41. The driving apparatus as recited in Claim 30 wherein said
3 first and second initialization signals and said first and second addressing
4 signals comprise bipolar electrical waveforms.

4

42. A method of driving a cholesteric liquid crystal (CLC) display having a plurality of controllable display elements, said CLC display having a matrix of row and column electrodes that define each of said controllable display elements, said method of driving comprising:

selectively initializing at least one of said controllable display elements by applying a first initialization signal to at least one of said column electrodes and a second initialization signal to at least one of said row electrodes, said first and second initialization signals cooperating to drive said at least one of said controllable display elements into a nematic phase and subsequently to drive said at least one of said controllable display elements to a cholesteric phase focal-conic state; and

selectively addressing said at least one of said controllable display elements by applying a first addressing signal to said at least one of said column electrodes and a second addressing signal to said at least one of said row electrodes, said first and second addressing signals cooperating to selectively drive said at least one of said controllable display elements from said cholesteric phase focal-conic state to a state having a given reflectivity.

43. The method of driving as recited in Claim 42 wherein each of said first and second initialization signals comprises a first sequence of pulses having a first amplitude and a second sequence of pulses having a second amplitude, said first sequence of pulses driving selected ones of said controllable display elements into said nematic phase and said second sequence of pulses driving said selected ones of said controllable display elements to said cholesteric phase focal-conic state.

2 44. The method of driving as recited in Claim 43 wherein said
3 first and second amplitudes are a function of a composition and thickness
of a CLC in said CLC display.

2 45. The method of driving as recited in Claim 43 wherein said
first and second sequence of pulses have a frequency of about 14.3 kHz.

2 46. The method of driving as recited in Claim 43 wherein said
3 first sequence of pulses has a duration of about 2 ms and said second
sequence of pulses has a duration of about 4 ms.

2 47. The method of driving as recited in Claim 42 wherein said
3 first and second addressing signals comprise a sequence of addressing
4 pulses having first and second predetermined amplitudes, respectively,
5 said step of selectively addressing comprising the step of driving ones of
6 said controllable display elements to said state having said given
reflectivity by varying a duration of said sequence of addressing pulses.

2 48. The method of driving as recited in Claim 47 wherein said
3 first and second predetermined amplitudes are a function of a composition
and thickness of a CLC in said CLC display.

2 49. The method of driving as recited in Claim 47 wherein said
first and second sequence of pulses have a frequency of about 14.3 kHz.

2 50. The method of driving as recited in Claim 47 wherein said
3 sequence of addressing pulses is preceded by a first sequence of pulses
4 having an amplitude less than a minimum amplitude necessary to drive
5 said CLC from the focal-conic state, a duration of said first sequence of
6 pulses varied such that the sum of the duration of the first sequence of
7 pulses and the duration of the sequence of addressing pulses has a constant
 value.

2 51. The method of driving as recited in Claim 42 wherein said
3 step of selectively initializing comprises simultaneously applying said first
4 and second initialization signals to each of said plurality of controllable
 display elements.

2 52. The method of driving as recited in Claim 42 wherein said
3 step of selectively initializing is performed on at least a first selected row
4 of said plurality of controllable display elements while said step of
5 selectively addressing is performed simultaneously therewith on at least
 a second selected row of said plurality of controllable display elements.

2 53. The method of driving as recited in Claim 42 wherein said
3 first and second initialization signals and said first and second addressing
 signals comprise bipolar electrical waveforms.

2 54. A cholesteric liquid crystal (CLC) display system
3 comprising:
4 a CLC panel having a plurality of controllable display elements,
5 said CLC panel having a matrix of row and column electrodes that define
6 each of said controllable display elements;
7 a data circuit coupled to said column electrodes for selectively
8 applying a first initialization signal and a first addressing signal to each
9 of said plurality of controllable display elements; and
10 a scan circuit coupled to said row electrodes for selectively
11 applying a second initialization signal and a second addressing signal to
12 each of said plurality of controllable display elements, said first and
13 second initialization signals cooperating to drive said controllable display
14 elements into a nematic phase and subsequently to drive said controllable
15 display elements to a cholesteric phase focal-conic state, said first and
16 second addressing signals cooperating to selectively drive said controllable
17 display elements from said cholesteric phase focal-conic state to a state
 having a given reflectivity.

2 55. The CLC display system as recited in Claim 54 wherein
3 each of said first and second initialization signals comprises a first
4 sequence of pulses having a first amplitude and a second sequence of
5 pulses having a second amplitude, said first sequence of pulses driving
6 selected ones of said plurality of controllable display elements into said
7 nematic phase and said second sequence of pulses driving said selected
8 ones of said controllable display elements to said cholesteric phase focal-
 conic state.

2 56. The CLC display system as recited in Claim 54 wherein
3 said first and second addressing signals comprise a sequence of addressing
4 pulses having first and second predetermined amplitudes, respectively,
5 said CLC display system operative to drive said controllable display
6 elements from said cholesteric phase focal-conic state to said state having
7 said given reflectivity by varying a duration of said sequence of
8 addressing pulses.

 57. The CLC display system as recited in Claim 56 wherein
2 said sequence of addressing pulses is preceded by a first sequence of
3 pulses having an amplitude less than a minimum amplitude necessary to
4 drive said CLC from the focal-conic state, a duration of said first
5 sequence of pulses varied such that the sum of the duration of the first
6 sequence of pulses and the duration of the sequence of addressing pulses
7 has a constant value.

 58. The CLC display system as recited in Claim 54 wherein
2 said first and second initialization signals are applied simultaneously to
3 each of said plurality of controllable display elements.

 59. The CLC display system as recited in Claim 54 wherein
2 said first and second initialization signals are applied to at least a first
3 selected row of said plurality of controllable display elements, said first
4 and second addressing signals being applied simultaneously therewith to
5 at least a second selected row of said plurality of controllable display
6 elements.

60. The CLC display system as recited in Claim 54 wherein
2 said first and second initialization signals and said first and second
3 addressing signals comprise bipolar electrical waveforms.

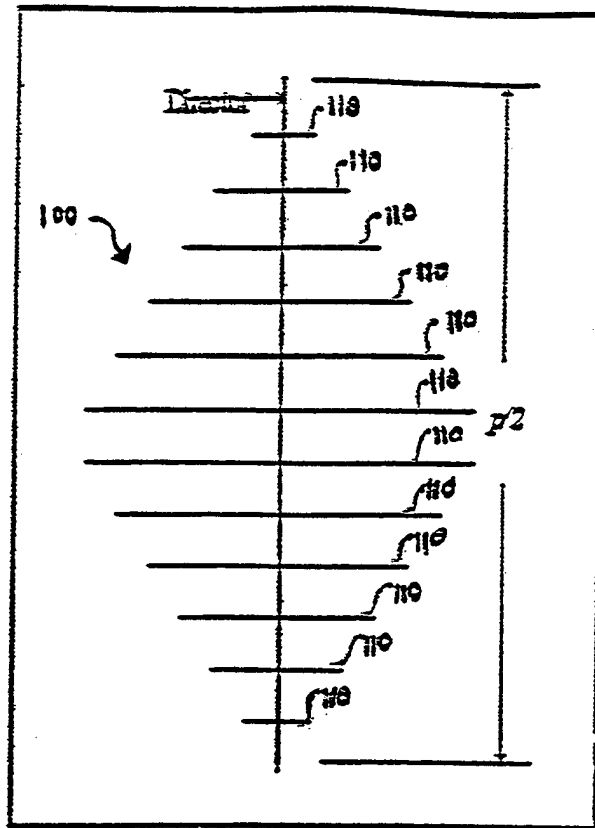


FIGURE 1A

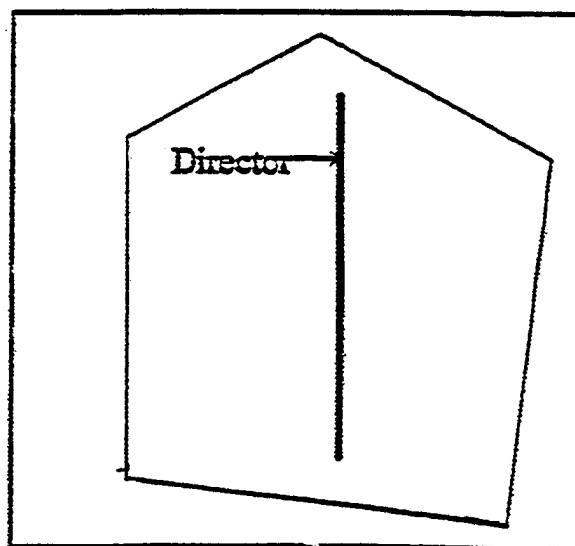


FIGURE 1B

2/17

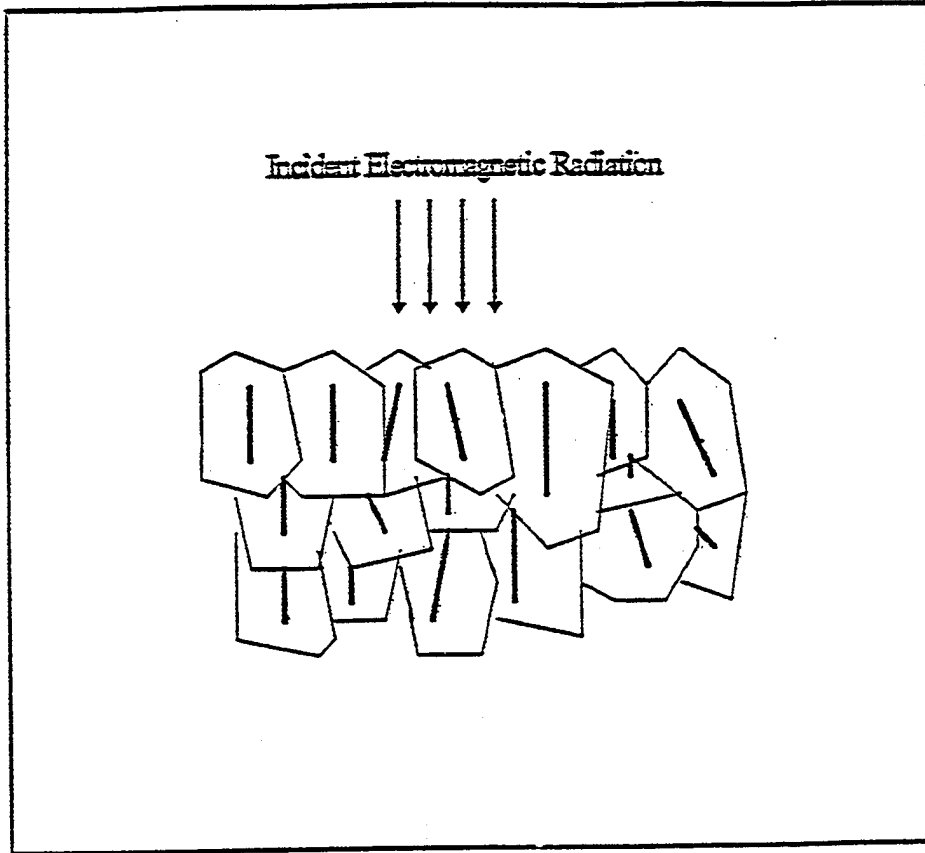


FIGURE 2

3/17

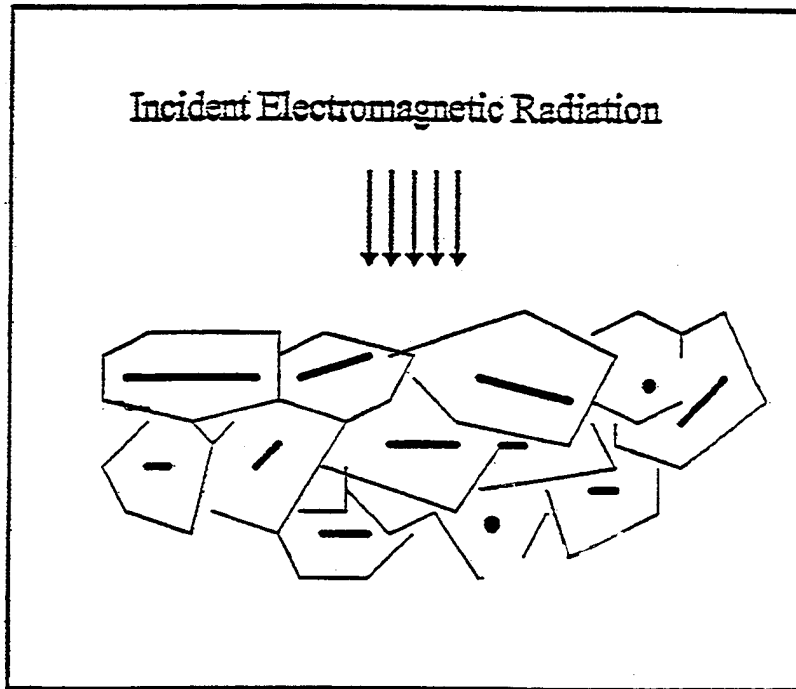


FIGURE 3

4/17

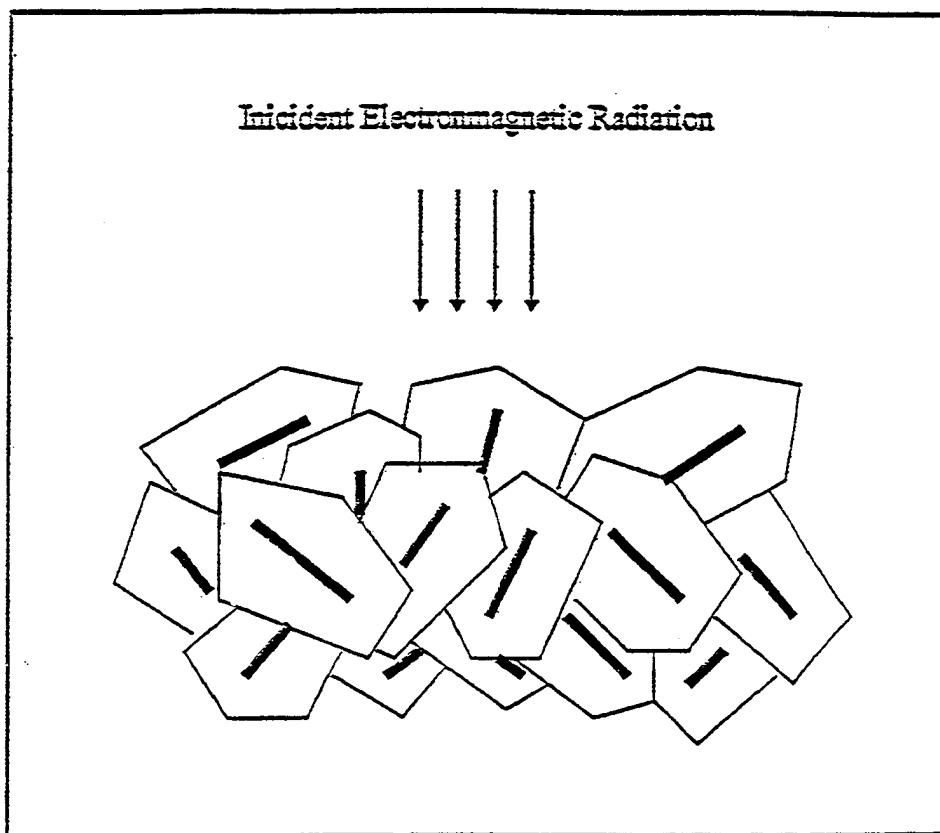


FIGURE 4

5/17

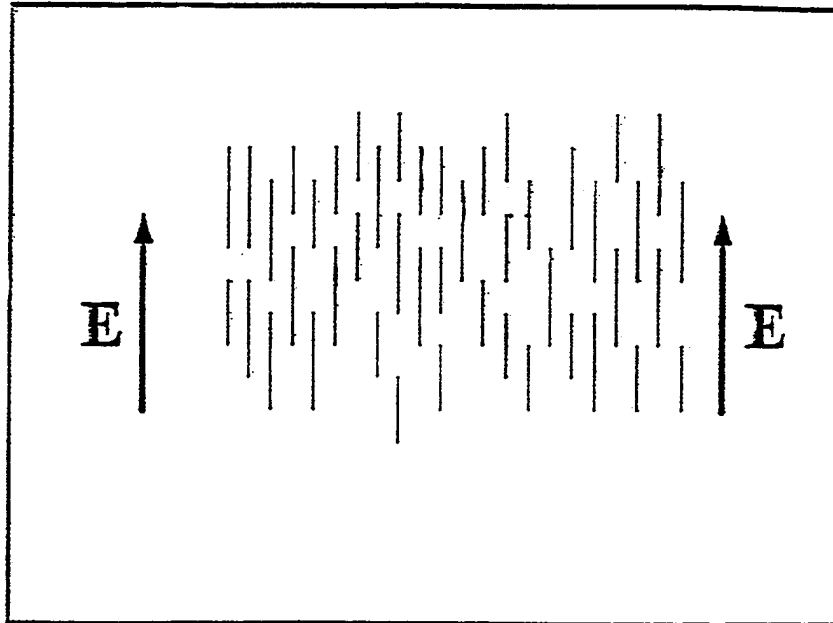


FIGURE 5

6/17

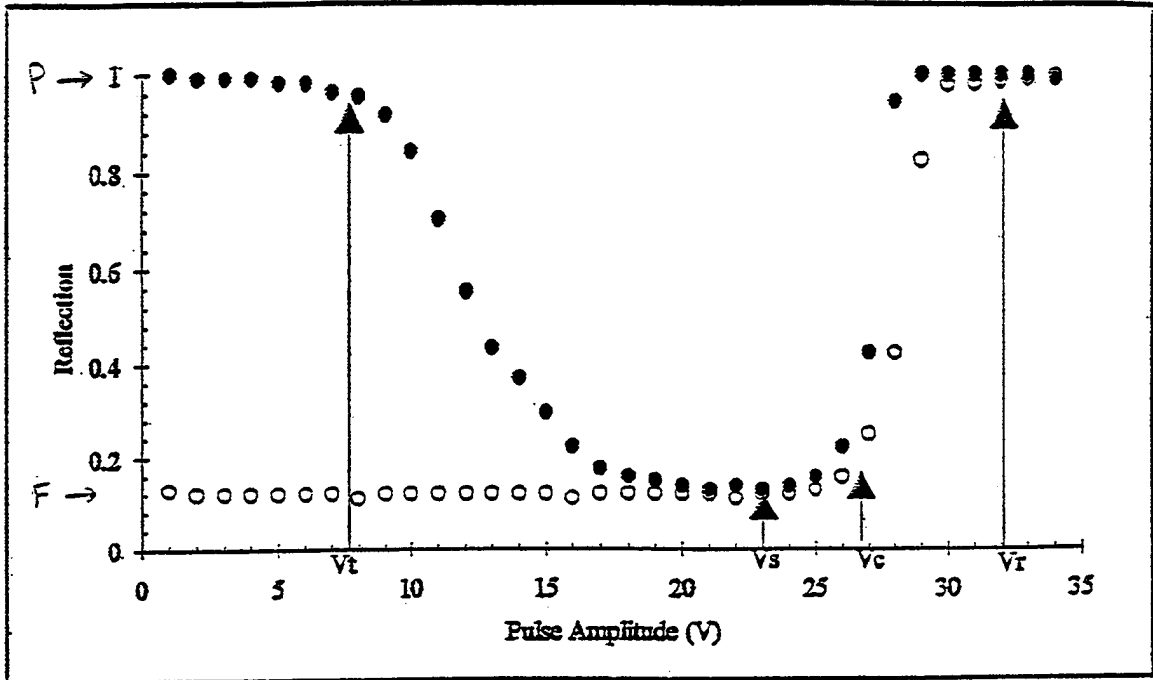


FIGURE 6

7/17

FIGURE 7A

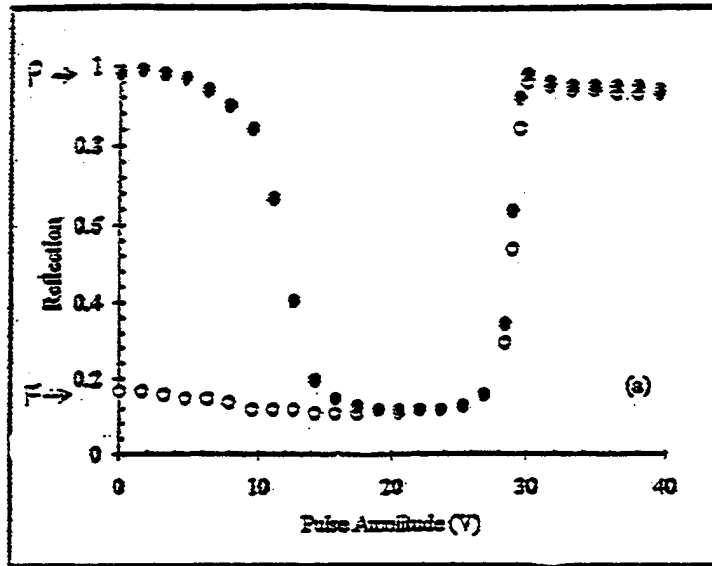
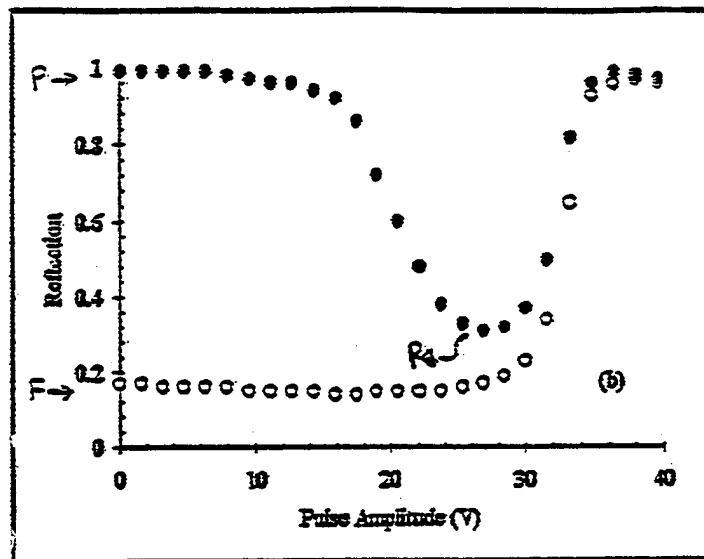


FIGURE 7B



8/17

FIGURE 7C

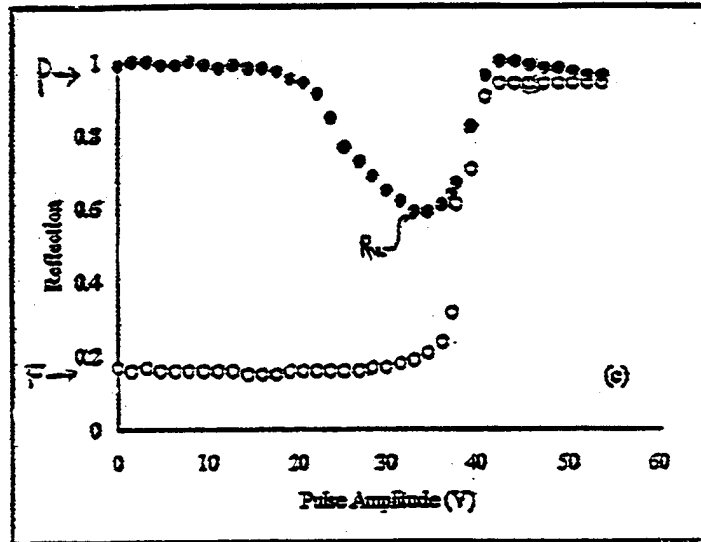
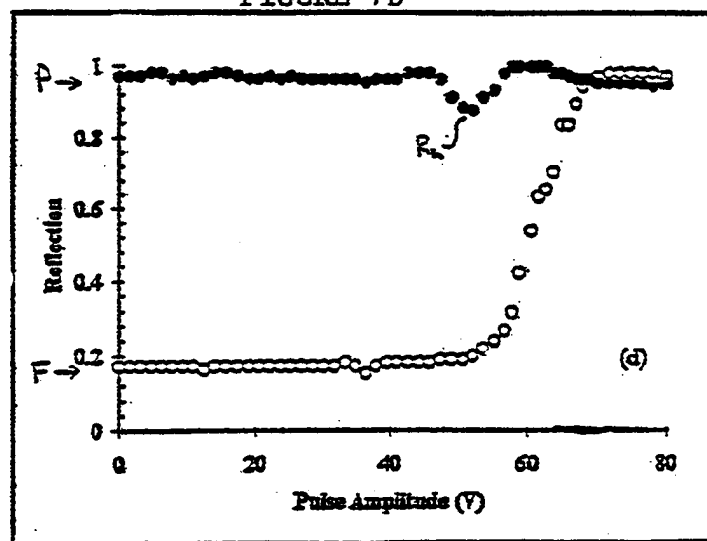


FIGURE 7D



9/17

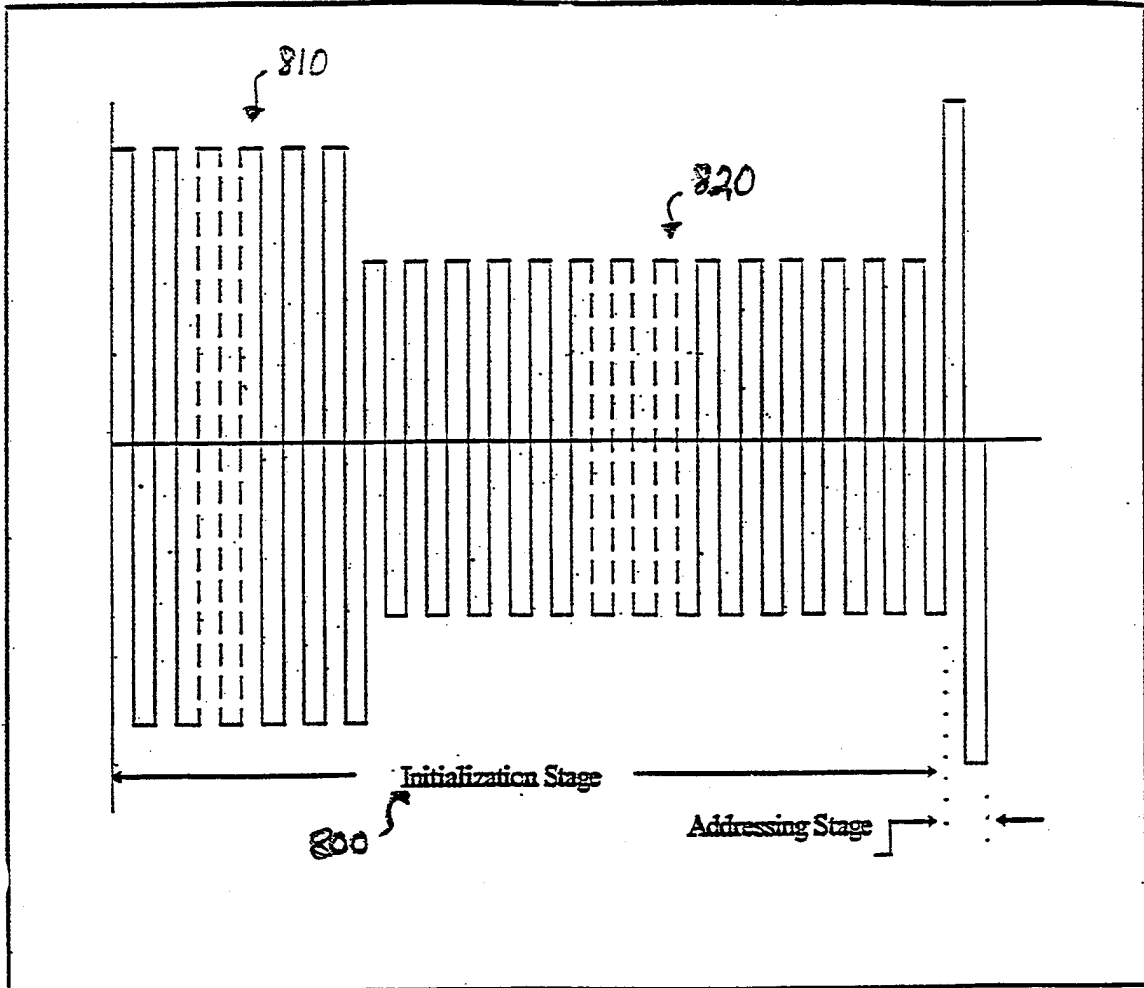


FIGURE 8

10/17

FIGURE 9A

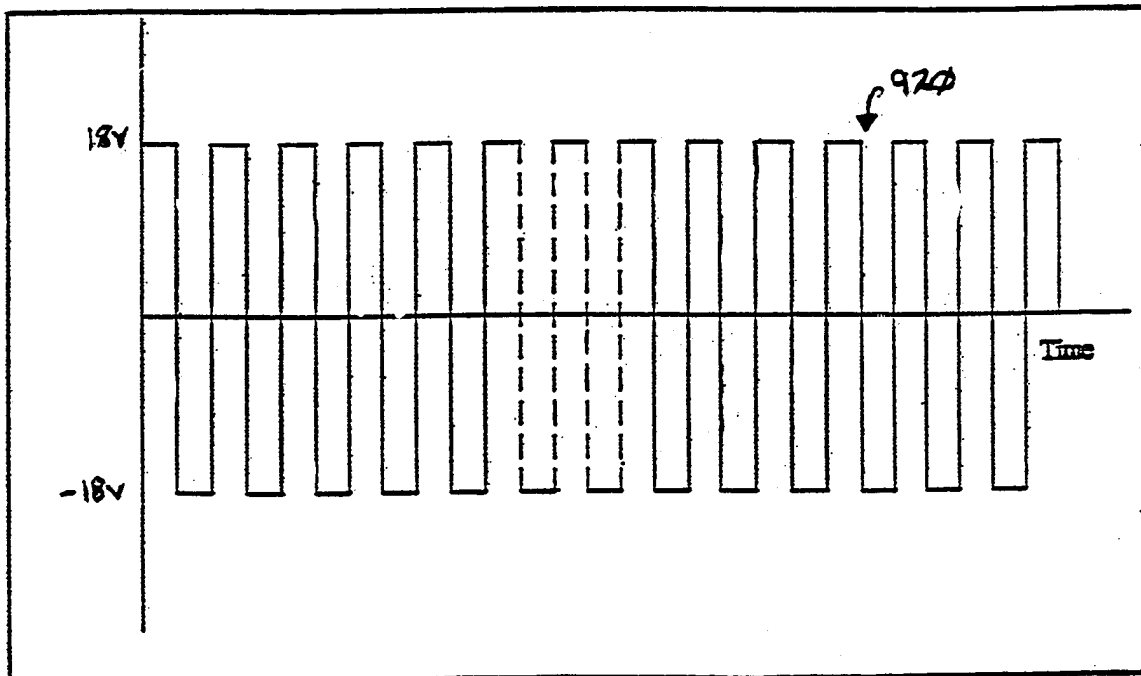
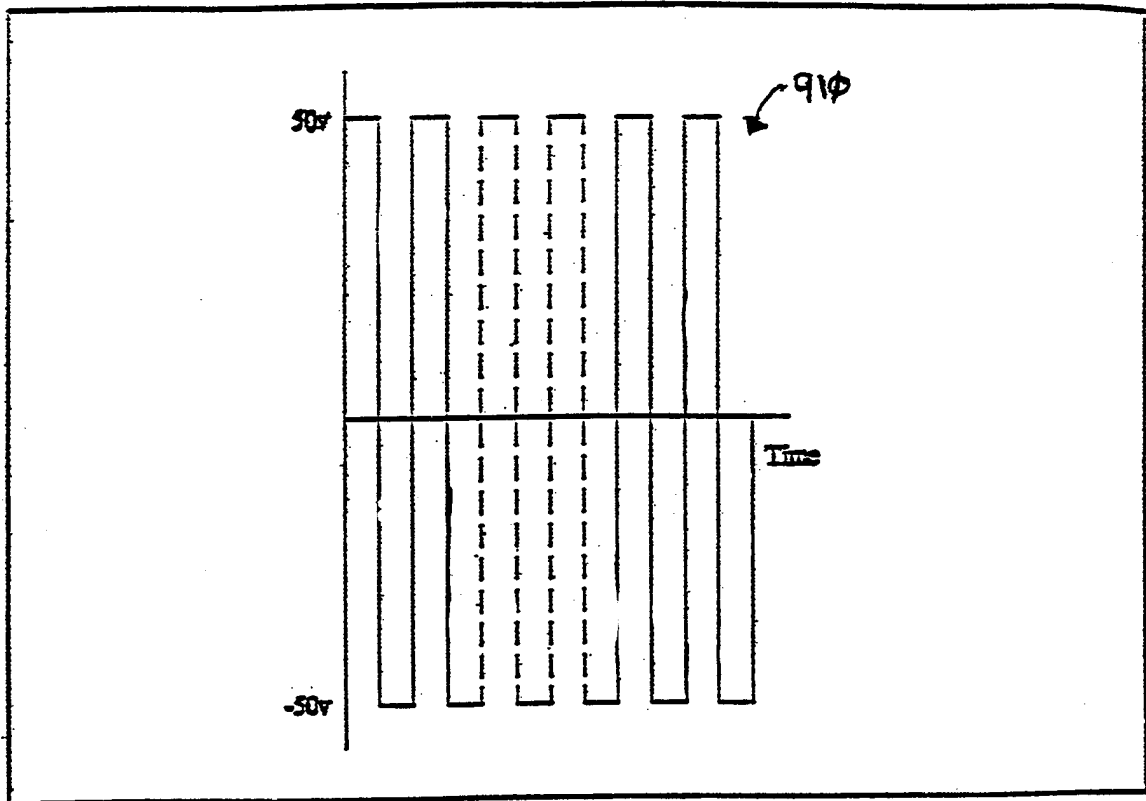


FIGURE 9B

11/17

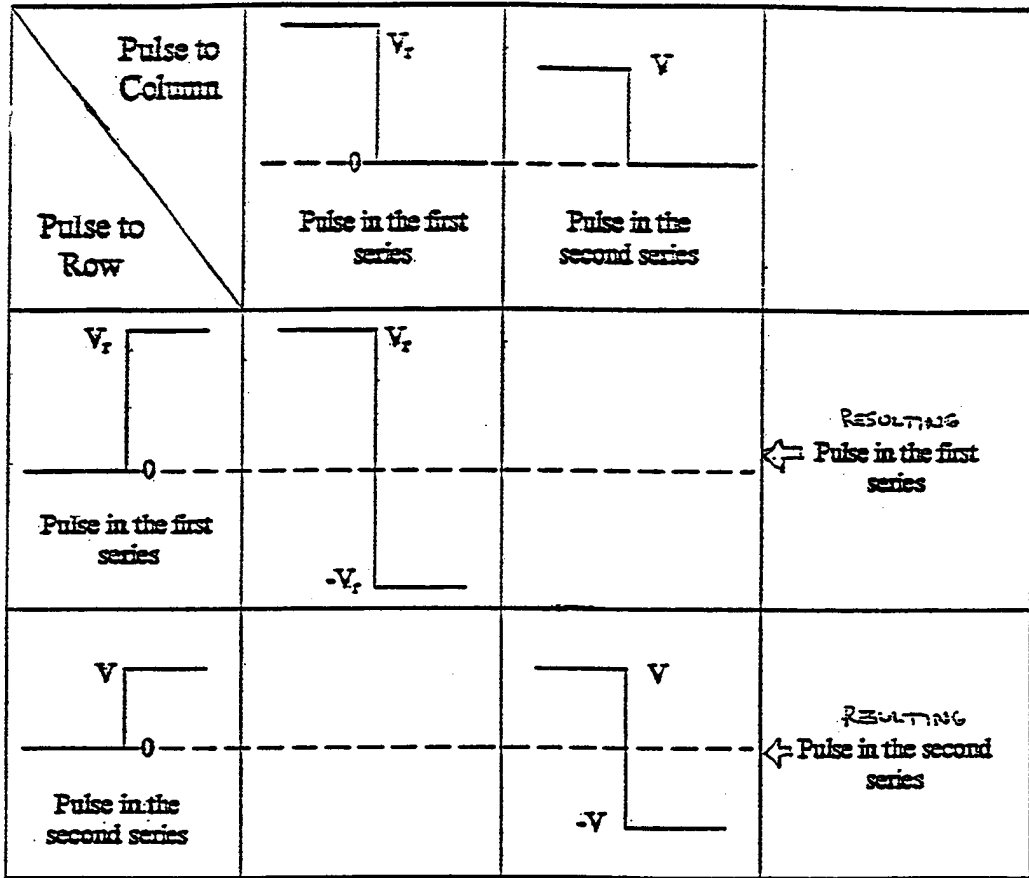


FIGURE 10

12/17

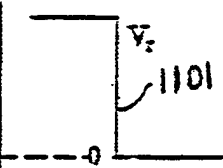
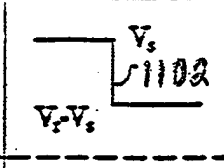
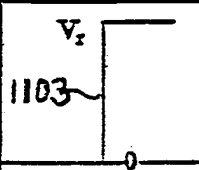
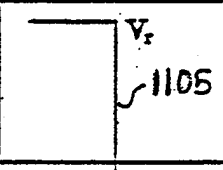
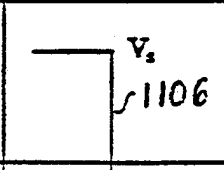
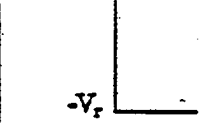
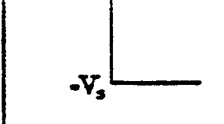
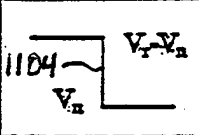
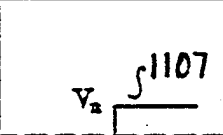
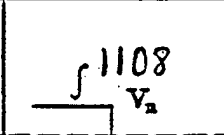
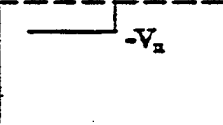
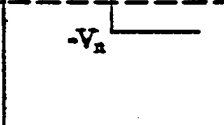
Pulse to Column			
	0		
Pulse to Row	ON	OFF	
			Addressing
selected row driving pulse			
			No Effect
non-selected row driving pulse			

FIGURE 11

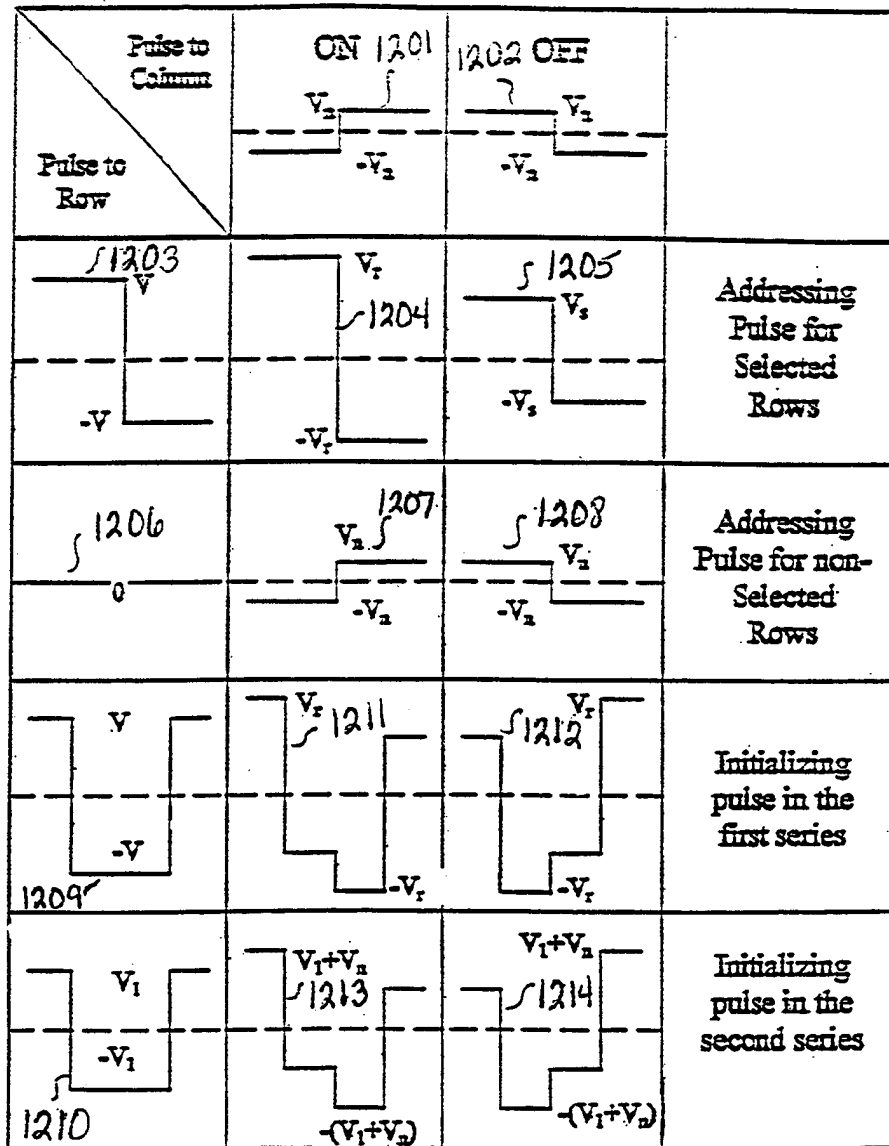


FIGURE 12

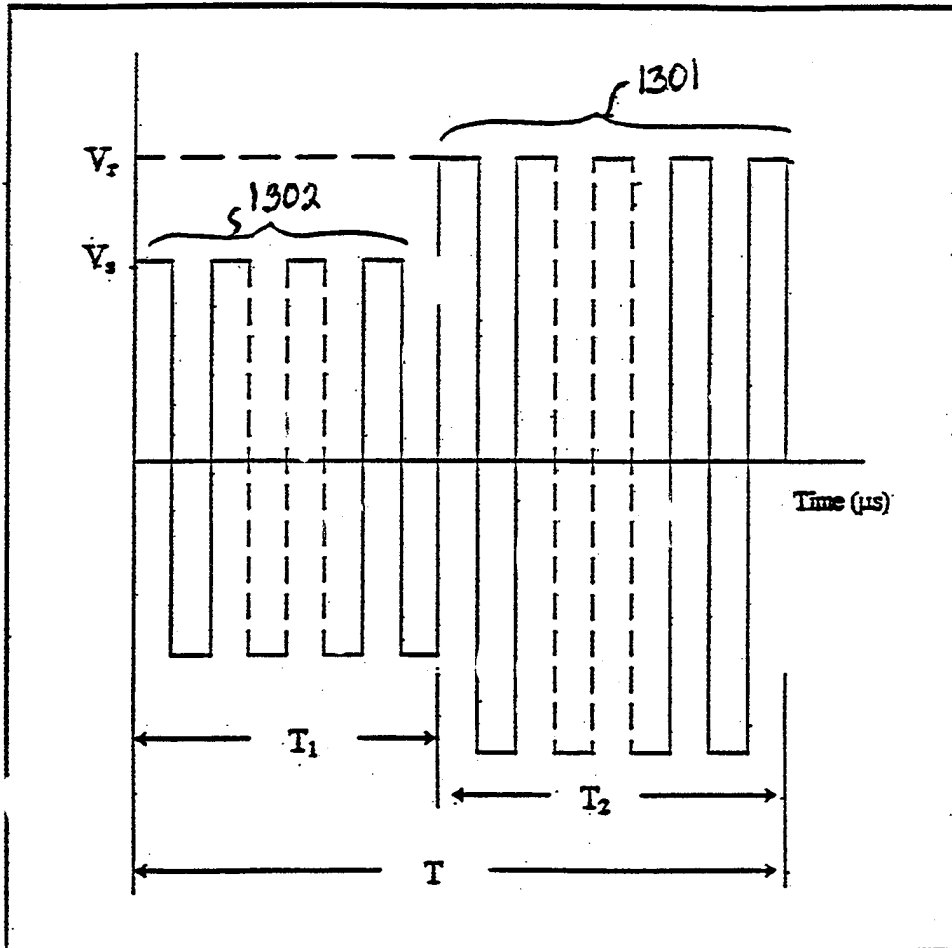


FIGURE 13

15/17

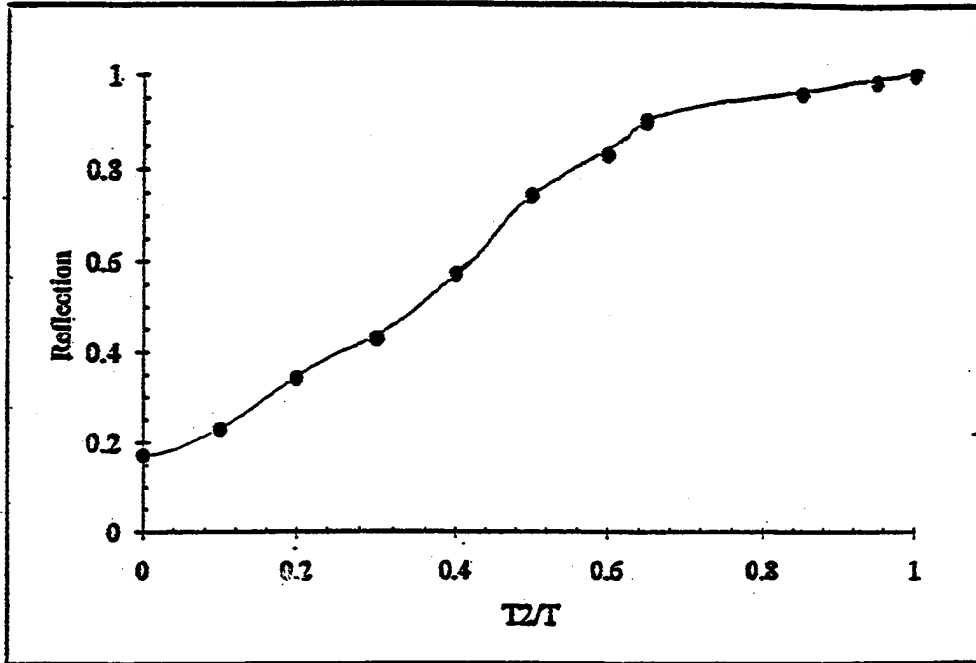


FIGURE 14

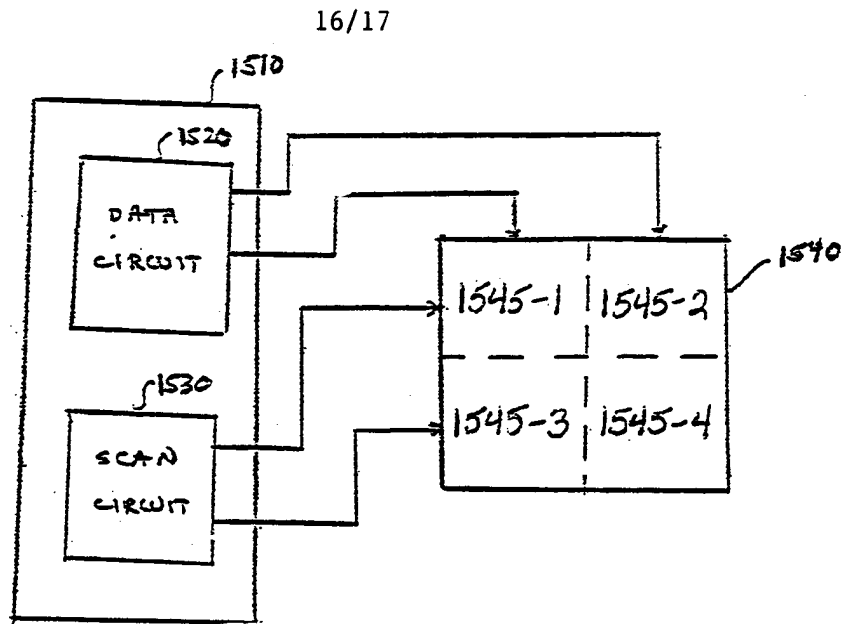


FIGURE 15.

FIGURE 16A

17/17

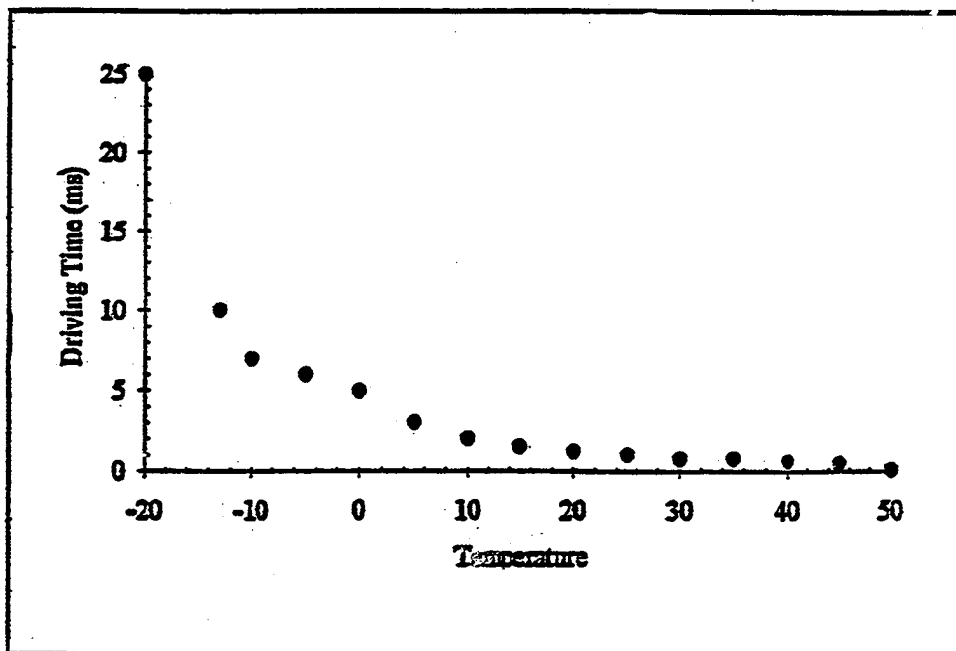
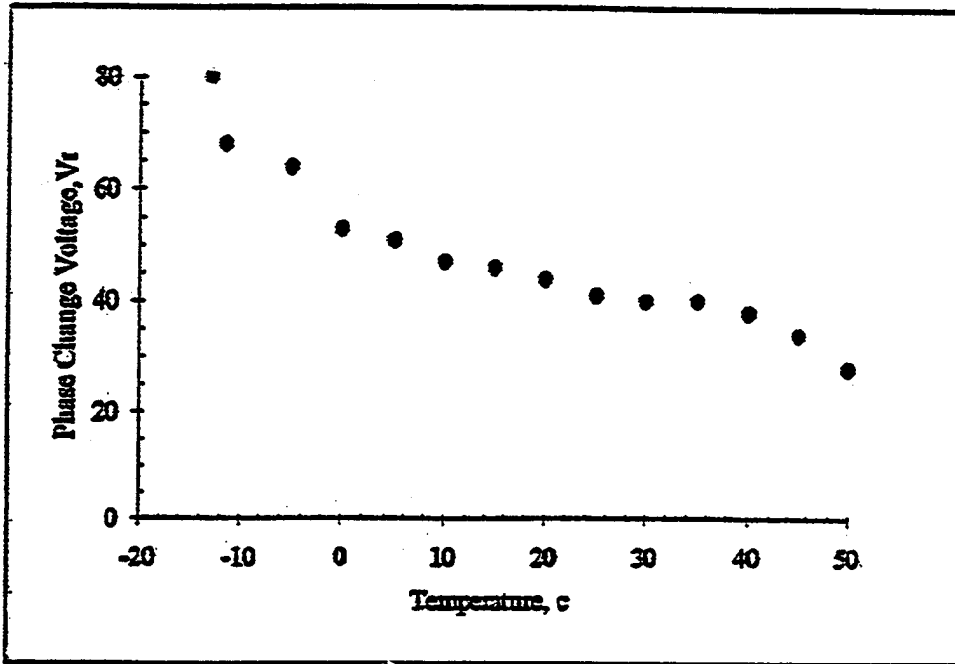


FIGURE 16B

INTERNATIONAL SEARCH REPORT

International Application No
PCT/US 98/00108

A. CLASSIFICATION OF SUBJECT MATTER
IPC 6 G09G3/36

According to International Patent Classification (IPC) or to both national classification and IPC

B. FIELDS SEARCHED

Minimum documentation searched (classification system followed by classification symbols)
IPC 6 G09G

Documentation searched other than minimum documentation to the extent that such documents are included in the fields searched

Electronic data base consulted during the international search (name of data base and, where practical, search terms used)

C. DOCUMENTS CONSIDERED TO BE RELEVANT

Category °	Citation of document, with indication, where appropriate, of the relevant passages	Relevant to claim No.
Y	PATENT ABSTRACTS OF JAPAN vol. 9, no. 232 (P '389! , 18 September 1995 -& JP 60 086525 A (FUJITSU K.K.), 16 May 1985, see abstract --- -/--	1-7, 10-12, 20-22, 42-44, 54, 55

Further documents are listed in the continuation of box C.

Patent family members are listed in annex.

° Special categories of cited documents :

- "A" document defining the general state of the art which is not considered to be of particular relevance
- "E" earlier document but published on or after the international filing date
- "L" document which may throw doubts on priority claim(s) or which is cited to establish the publication date of another citation or other special reason (as specified)
- "O" document referring to an oral disclosure, use, exhibition or other means
- "P" document published prior to the international filing date but later than the priority date claimed

- "T" later document published after the international filing date or priority date and not in conflict with the application but cited to understand the principle or theory underlying the invention
- "X" document of particular relevance; the claimed invention cannot be considered novel or cannot be considered to involve an inventive step when the document is taken alone
- "Y" document of particular relevance; the claimed invention cannot be considered to involve an inventive step when the document is combined with one or more other such documents, such combination being obvious to a person skilled in the art.
- "&" document member of the same patent family

Date of the actual completion of the international search

29 May 1998

Date of mailing of the international search report

05/06/1998

Name and mailing address of the ISA

European Patent Office, P.B. 5818 Patentlaan 2
 NL - 2280 HV Rijswijk
 Tel. (+31-70) 340-2040, Tx. 31 651 epo nl,
 Fax: (+31-70) 340-3016

Authorized officer

Corsi, F

INTERNATIONAL SEARCH REPORT

International Application No
PCT/US 98/00108

C.(Continuation) DOCUMENTS CONSIDERED TO BE RELEVANT		
Category °	Citation of document, with indication, where appropriate, of the relevant passages	Relevant to claim No.
Y	<p>US 4 571 585 A (STEIN ET AL.) 18 February 1986</p> <p>see Abstract see column 1, line 24 - line 55 see column 3, line 30 - column 4, line 59; figures 1-1B see column 6, line 6 - column 8, line 63; figures 3A-5 see column 9, line 26 - line 48</p> <p>---</p>	<p>1-7, 10-12, 20-22, 42-44, 54,55</p>
A	<p>D.K.YANG ET AL.: "Cholesteric reflective display: Drive scheme and contrast" APPLIED PHYSICS LETTERS., vol. 64, no. 11, April 1994, NEW YORK US, pages 1905-1907, XP000440923 see the whole article</p> <p>---</p>	
A	<p>EP 0 491 377 A (SUMITOMO ELECTRIC INDUSTRIES LTD.) 24 June 1992</p> <p>see Abstract see column 12, line 48 - column 14, line 11; figure 1</p> <p>---</p>	<p>2-4,11, 21,31, 43,55</p>
A	<p>US 5 093 737 A (KANBE ET AL.) 3 March 1992</p> <p>see Abstract see column 11, line 48 - line 54; figures 14,16,1717</p> <p>-----</p>	<p>8,15,25, 35,47,56</p>

INTERNATIONAL SEARCH REPORT

information on patent family members

International Application No

PCT/US 98/00108

Patent document cited in search report	A	Publication date	Patent family member(s)	Publication date
US 4571585	A	18-02-1986	NONE	
<hr style="border-top: 1px dashed black;"/>				
EP 491377	A	24-06-1992	JP 4249216 A	04-09-1992
			JP 4217294 A	07-08-1992
			CA 2057965 A	20-06-1992
			DE 69109641 D	14-06-1995
			DE 69109641 T	19-10-1995
			US 5216415 A	01-06-1993
<hr style="border-top: 1px dashed black;"/>				
US 5093737	A	03-03-1992	JP 2073058 C	25-07-1996
			JP 7086605 B	20-09-1995
			JP 61022325 A	30-01-1986
			JP 1604411 C	22-04-1991
			JP 60172029 A	05-09-1985
			JP 62061930 B	24-12-1987
			US 5436743 A	25-07-1995
			US 5717419 A	10-02-1998
			US 5724059 A	03-03-1998
			US 5633652 A	27-05-1997
			US 5418634 A	23-05-1995
			US 5381254 A	10-01-1995
<hr style="border-top: 1px dashed black;"/>				