

(19) World Intellectual Property Organization  
International Bureau



(43) International Publication Date  
16 December 2004 (16.12.2004)

PCT

(10) International Publication Number  
WO 2004/110086 A1

(51) International Patent Classification<sup>7</sup>: H04Q 7/30,  
H04B 1/26

(21) International Application Number:  
PCT/IB2004/050776

(22) International Filing Date: 26 May 2004 (26.05.2004)

(25) Filing Language: English

(26) Publication Language: English

(30) Priority Data:  
03101641.3 5 June 2003 (05.06.2003) EP

(71) Applicant (for all designated States except US): KONINKLIJKE PHILIPS ELECTRONICS N.V. [NL/NL]; Groenewoudseweg 1, NL-5621 BA Eindhoven (NL).

(72) Inventors; and

(75) Inventors/Applicants (for US only): COLLADOS ASENSIO, Manel [ES/NL]; c/o Prof. Holstlaan 6, NL-5656 AA Eindhoven (NL). DE JONG, Gerben, W. [NL/NL]; c/o Prof. Holstlaan 6, NL-5656 AA Eindhoven (NL).

(74) Agent: ELEVELD, Koop, J.; Prof. Holstlaan 6, NL-5656 AA Eindhoven (NL).

(81) Designated States (unless otherwise indicated, for every kind of national protection available): AE, AG, AL, AM,

AT, AU, AZ, BA, BB, BG, BR, BW, BY, BZ, CA, CH, CN, CO, CR, CU, CZ, DE, DK, DM, DZ, EC, EE, EG, ES, FI, GB, GD, GE, GH, GM, HR, HU, ID, IL, IN, IS, JP, KE, KG, KP, KR, KZ, LC, LK, LR, LS, LT, LU, LV, MA, MD, MG, MK, MN, MW, MX, MZ, NA, NI, NO, NZ, OM, PG, PH, PL, PT, RO, RU, SC, SD, SE, SG, SK, SL, SY, TJ, TM, TN, TR, TT, TZ, UA, UG, US, UZ, VC, VN, YU, ZA, ZM, ZW.

(84) Designated States (unless otherwise indicated, for every kind of regional protection available): ARIPO (BW, GH, GM, KE, LS, MW, MZ, NA, SD, SL, SZ, TZ, UG, ZM, ZW), Eurasian (AM, AZ, BY, KG, KZ, MD, RU, TJ, TM), European (AT, BE, BG, CH, CY, CZ, DE, DK, EE, ES, FI, FR, GB, GR, HU, IE, IT, LU, MC, NL, PL, PT, RO, SE, SI, SK, TR), OAPI (BF, BJ, CF, CG, CI, CM, GA, GN, GQ, GW, ML, MR, NE, SN, TD, TG).

Declaration under Rule 4.17:

— as to applicant's entitlement to apply for and be granted a patent (Rule 4.17(ii)) for the following designations AE, AG, AL, AM, AT, AU, AZ, BA, BB, BG, BR, BW, BY, BZ, CA, CH, CN, CO, CR, CU, CZ, DE, DK, DM, DZ, EC, EE, EG, ES, FI, GB, GD, GE, GH, GM, HR, HU, ID, IL, IN, IS, JP, KE, KG, KP, KR, KZ, LC, LK, LR, LS, LT, LU, LV, MA, MD, MG, MK, MN, MW, MX, MZ, NA, NI, NO, NZ, OM, PG, PH, PL, PT, RO, RU, SC, SD, SE, SG, SK, SL, SY, TJ, TM, TN, TR, TT, TZ, UA, UG, UZ, VC, VN, YU, ZA, ZM, ZW, ARIPO patent (BW, GH, GM, KE, LS, MW, MZ, NA,

[Continued on next page]

(54) Title: FREQUENCY MULTIPLEXED ARCHITECTURE

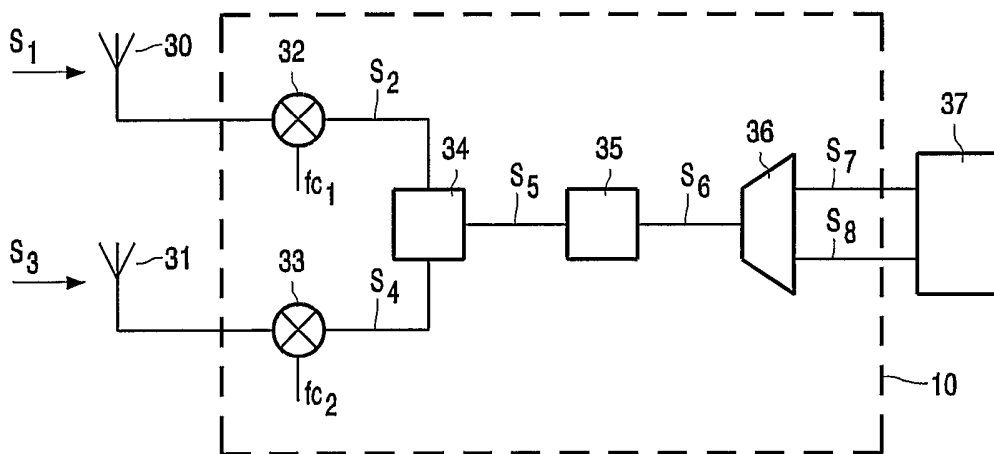

(57) Abstract: A receiver (10) is arranged to simultaneously receive at least a first (S1) radio frequency signal having a first frequency band (1) and a second radio frequency signal (S3) having a second frequency band (3) that is at least partly overlapping the first frequency band (1). The receiver has frequency down-conversion means (32,33) for frequency down converting the at least first (S1) and second radio frequency signals (S3) to at least a first (S2) and a second (S4) lower frequency signal and multiplexing means (34) for sequentially multiplexing the at least first (S2) and second lower frequency signals (S4) into a frequency multiplexed signal (S5).

WO 2004/110086 A1



*SD, SL, SZ, TZ, UG, ZM, ZW), Eurasian patent (AM, AZ, BY, KG, KZ, MD, RU, TJ, TM), European patent (AT, BE, BG, CH, CY, CZ, DE, DK, EE, ES, FI, FR, GB, GR, HU, IE, IT, LU, MC, NL, PL, PT, RO, SE, SI, SK, TR), OAPI patent (BF, BJ, CF, CG, CI, CM, GA, GN, GQ, GW, ML, MR, NE, SN, TD, TG)*

**Published:**

— *with international search report*

*For two-letter codes and other abbreviations, refer to the "Guidance Notes on Codes and Abbreviations" appearing at the beginning of each regular issue of the PCT Gazette.*

### Frequency multiplexed architecture

The invention relates to a receiver arranged to simultaneously receive at least a first radio frequency signal having a first frequency band and a second radio frequency signal having a second frequency band that is at least partly overlapping the first frequency band.

5 The invention also relates to a transmitter, to a transceiver, to a method of receiving and to a method of simultaneously transmitting.

The present invention can be used in telecommunication systems such as Multiple Input Multiple Output or MIMO systems, where a transmitter comprises a first number of parallel transmitting branches arranged to simultaneously and parallelly transmit data, and where the receiver comprises a second number of parallel receiving branches  
10 arranged to simultaneously and parallelly receive data. The first number of transmitting branches can be equal to, or differ from, the second number of receiving branches. By using these parallel branches, enhancement of data rate and/or channel capacity can be achieved. MIMO systems are used in for example cellular radio systems such as GSM or UMTS, wireless radio systems such as DECT and in wireless networks such as LANs, WANs or  
15 PANs.

A prior art telecommunication system is known from US 6,314,147 which discloses a receiver comprising several parallel (analogue) receiving branches that are  
20 coupled to inputs of a digital receiver.

It is an object of the present invention to provide an improved receiver for use in for example MIMO systems. To this end, the receiver is arranged to simultaneously  
25 receive at least a first radio frequency signal having a first frequency band and a second radio frequency signal having a second frequency band that is at least partly overlapping the first frequency band, the receiver comprising:

- frequency down-converting means for frequency down-converting the at least first and second radio frequency signals to at least a first and a second lower frequency

signal;

- multiplexing means for sequentially multiplexing the at least first and second lower frequency signals into a frequency multiplexed signal;

The invention is based upon the insight that noise sources can introduce  
5 correlated noise into the parallel receiving branches that is added to the received signals. For example, when the invention is realized in silicon and/or the receiving branches share a common synthesizer for processing the received signals, or when there is a common noise source somewhere on the silicon. Correlated noise can lower the data rate and/or the channel capacity of the receiver. The invention is further based upon the insight that by frequency  
10 multiplexing the received at least first and second radio frequency signals into a single frequency multiplexed signal, noise sources no longer can introduce correlated noise into the received signals, because, due to the sequential frequency multiplexing the frequency bands of the first and second lower frequency signals are separated in frequency. That is, each signal comprised in the frequency multiplexed signal is affected with different –uncorrelated  
15 - spectral components of the noise source.

In an embodiment according to the present invention, the receiver further comprises an analogue to digital converter for digitizing the frequency multiplexed signal. By multiplexing the information contained in the received radio frequency signals into a single frequency multiplexed signal, only a single analogue to digital converter (ADC) is required to  
20 digitize the received signals in contrast to, a single ADC per received signal.

In an embodiment according to the present invention, the receiver further comprises demultiplexing means for demultiplexing the digitized frequency multiplexed signal into at least a first and a second signal which is advantageous in that it enables a convenient processing of the digitized information.

25 In another embodiment according to the present invention a transmitter is arranged to simultaneously transmit at least a first radio frequency signal having a first frequency band and a second radio frequency signal having a second frequency band that is at least partly overlapping the first frequency band, the transmitter comprising:

- signal multiplexing means for sequentially multiplexing at least a first and a  
30 second signal into a frequency multiplexed signal;

- demultiplexing means for demultiplexing the frequency multiplexed signal into at least a first and a second lower frequency signal; and

- frequency up-converting means for frequency up-converting the first lower frequency signal into the first radio frequency signal and for frequency up-converting the

second lower frequency signal into the second radio frequency signal. This embodiment has the advantage that by sequentially multiplexing the first and second signals into a single frequency multiplexed signal, noise sources can no longer introduce correlated noise into signals.

5                   In an embodiment according to the present invention, the multiplexing means comprises a digital to analogue converter (DAC) for converting the sequentially multiplexed first and second digital signals to a frequency multiplexed signal. This embodiment has the advantage that only a single DAC is required for converting the digital signals to a frequency multiplexed signal.

10                   Embodiments of a transceiver according to the present invention, of a receiving method according to the present invention and a transmission method according to the present invention correspond with the embodiments of the transmitter and receiver according to the present invention.

15                   These and other aspects of the invention will be apparent from and elucidated with reference to the embodiments described hereinafter

Fig. 1 shows the frequency bands of two radio frequency signals according to the present invention.

20                   Fig. 2 shows a frequency multiplexed signal comprising the frequency bands of two sequentially multiplexed lower frequency signals.

Fig. 3 shows a receiver according to the present invention.

Fig. 4 shows a transmitter according to the present invention.

Fig. 4a shows a multiplexer according to the present invention.

25                   Fig. 4b shows a further multiplexer according to the present invention.

Fig. 5 shows a transceiver according to the present invention

Fig. 6 shows a flow chart of a method for receiving radio frequency signals according to the present invention.

30                   Fig. 7 shows a flow chart of a method for transmitting radio frequency signals according to the present invention.

Fig. 1 shows the frequency bands 1 and 3 of two radio frequency signals that are having, by means example, equal bandwidths ( $f_2-f_1$ ) that are fully overlapping i.e. they

occupy the same frequency range. As an example, single sideband signals have been assumed. Alternatively, the frequency bands 1 and 3 may also partly overlap.

Fig. 2 shows a frequency multiplexed signal comprising frequency bands 1 and 3. By means of example the frequency bands 1 and 3 are separated by means of guard band G. The frequency multiplexed signal occupies a total bandwidth B.

Fig. 3 shows a receiver 10 according to the present invention having, by means of example, two antennas 30 and 31 for receiving two radio frequency signals S1 and S2. Receiver 10 comprises mixers 32 and 33 for frequency down-converting the received radio frequency signals S1 and S3 into lower frequency signals S2 and S3. By means of multiplexer 34, signals S2 and S4 are sequentially multiplexed into frequency multiplexed signal S5. Multiplexer 34 could e.g. comprise a conventional adding element for adding the signals S2 and S4 together. Analogue to digital converter 35 is used to digitize the frequency multiplexed signal S5. Herewith, S6 comprises the digitized spectra of signals S2 and S4. In order to satisfy Shannon's law, the working speed of the analogue to digital converter 35 should be at least be twice the frequency band B of the frequency multiplexed signal S5. By means of demultiplexing unit 36, digital signals S7, S8 can be recovered so that they can be used for further processing in processing means 37. The information comprised in S7 and S8 corresponds to the information comprised in S1 and S3. Although, in contrast to S1 and S3, signals S7 and S8 are digital signals. The embodiment as shown in Fig. 3 has the advantage that noise sources cannot introduce correlated noise into the sequentially multiplexed signal S5. The embodiment has the further advantage that only a single digital to analogue converter 37 is required to digitize all received signals.

Fig. 4 shows a transmitter 20 according to the present invention. Shown are two signals S10 and S11 that have been processed by processing means 40. By means of multiplexing means 41, signals S10 and S11 are frequency multiplexed into signal S12. In principle signals S10 and S11 can be digital or analogue. In case of digital signals S10 or S11, the multiplexing means 41 can be constructed as shown in Fig. 4a, wherein the multiplexing means comprises a multiplexer 59 for sequentially multiplexing the digital signals S10 and S11 into signal S12d. By means of digital to analogue converter (53) signal S12d is subsequently converted into the analogue frequency multiplexed signal S12. In case S10 and S11 are analogue signals, the multiplexer could be constructed as shown in Fig. 4b where multipliers 54 and 55 are used to shift the frequency of signals S10 and S11. Filters 56 and 57 e.g. bandpass filters are used to remove the unwanted spectral components after multiplication. By means of adder 58, the signals S10 and S11 are added together which

results in the frequency multiplexed signal S12. Therefore, S12 comprises two signals S13, S14 that are a representation of the original signals S10 and S11. By means of demultiplexing unit 48 these two signals S13, S14 can be recovered e.g. by using bandpass filters 42 and 43. By means of multipliers 44 and 45 signals S13 and S14 are being frequency up-converted to signals S15 and S16, respectively. Signals S15 and S16 are subsequently being transmitted into the air via antennas 46 and 47. This embodiment has the advantage that a noise source cannot introduce correlated noise into the signals S10 and S11 once they are frequency multiplexed into signal S12. In addition the invention has the further advantage only a single digital to analogue converter 53 is required to convert digital signals S10 and S11 into a single frequency multiplexed signal S12.

Fig. 5, shows a transceiver 50 according to the present invention. The transceiver comprises antennas 51 and 52 for receiving and transmitting data. The transceiver comprises a receiver 10 and a transmitter 20 which are coupled to processing means (not shown here) for processing signals S7, S8 and S10 and S11.

Fig. 6 shows a flow chart of a method for receiving radio frequency signals according to the present invention. In the first step 60, the at least first and second radio frequency signals S1 and S3 are frequency down-converted into at least a first lower frequency S2 signal and a second lower frequency signal S3. In the second step 61, signals S2 and S3 are sequentially multiplexed into frequency multiplexed signal S5.

Fig. 7 shows a flow chart of a method for transmitting radio frequency signals according to the present invention. In the first step 70 the at least first and second signals S10 and S11 are sequentially multiplexed into a frequency multiplexed signal S12. Then in step 71, signal S12 is demultiplexed back into signals S13 and S14. Finally in step 72, signals S13 and S14 are frequency up-converted into the first radio frequency signal S15 and into the second radio frequency signal S16.

It is to be noted that the above-mentioned embodiments illustrate rather than limit the invention, and that those skilled in the art will be able to design many alternative embodiments without departing from the scope of the appended claims. The embodiments can be realized in either the analogue or digital domain using analogue and digital components. The word "comprising" does not exclude the presence of elements or steps other than those listed in a claim. The word "a" or "an" preceding an element does not exclude the presence of a plurality of such elements. The mere fact that certain measures are recited in mutually different dependent claims does not indicate that a combination of these measures cannot be used to advantage.

## CLAIMS:

1. Receiver (10) arranged to simultaneously receive at least a first (S1) radio frequency signal having a first frequency band (1) and a second radio frequency signal (S3) having a second frequency band (3) that is at least partly overlapping the first frequency band (1), the receiver comprising:
- 5 - frequency down-conversion means (32,33) for frequency down-converting the at least first (S1) and second radio frequency signals (S3) to at least a first (S2) and a second (S4) lower frequency signal;
- multiplexing means (34) for sequentially multiplexing the at least first (S2) and second lower frequency signals (S4) into a frequency multiplexed signal (S5).
- 10
2. Receiver (10) according to claim 1, wherein (10) the receiver further comprises an analogue to digital converter (35) for digitizing the frequency multiplexed signal (S5).
- 15
3. Receiver (10) according to claim 2, wherein the receiver (10) further comprises demultiplexing (36) means for demultiplexing the digitized frequency multiplexed signal (S6) into at least a first (S7) and a second (S8) signal.
4. Transmitter (20) arranged to simultaneously transmit at least a first radio
- 20 frequency signal (S15) having a first frequency band (1) and a second radio frequency signal (S16) having a second frequency band (3) that is at least partly overlapping the first frequency band (1), the transmitter (20) comprising:
- signal multiplexing means (41) for sequentially multiplexing at least a first (S10) and a second (S11) signal into a frequency multiplexed signal (S12);
- 25 - demultiplexing means (48) for demultiplexing the frequency multiplexed signal (S12) into at least a first (S13) and a second (S14) lower frequency signal;
- frequency up-converting means (44,45) for frequency up-converting the first lower frequency signal (S13) into the first radio frequency signal (S15) and for frequency up-



converting the second lower frequency signal (S14) into the second radio frequency signal (S16).

5. Transmitter (20) according to claim 4, wherein the at least first (S12) and  
5 second (S11) signals are digital signals.

6. Transmitter (20) according to claim 5, wherein the multiplexing means (41)  
comprises a digital to analogue converter (53) for converting the sequentially multiplexed  
first and second digital signals (S12d) to a frequency multiplexed signal (S12).

10

7. Transceiver (50) comprising a receiver (10) that is arranged to simultaneously  
receive at least a first radio frequency signal (S1) having a first frequency band (1) and a  
second radio frequency signal (S3) having a second frequency band (3) that is at least partly  
overlapping the first frequency band (1), the receiver (10) comprising:

15 - signal conversion means (32,33) for frequency down-converting the at least  
first (S1) and second radio frequency signals (S3) to at least a first (S2) and a second (S4)  
lower frequency signal;

- multiplexing means (34) for sequentially multiplexing the at least first (S2)  
and second lower (S4) frequency signals into a frequency multiplexed signal (S5);

20

8. Transceiver (50) according to claim 7, the transceiver further comprising a  
transmitter (20) that is arranged to simultaneously transmit at least a third radio frequency  
signal (S15) having a third frequency band (1) and a fourth radio frequency signal (S16)  
having a fourth frequency band (3) that is at least partly overlapping the third frequency band  
25 (1), the transmitter (20) comprising:

- signal multiplexing means (41) for sequentially multiplexing at least a third  
(S10) and a second (S11) signal into a frequency multiplexed signal (S12);

- demultiplexing means (48) for demultiplexing the frequency multiplexed  
signal (S12) into at least a third (S13) and a fourth (S14) lower frequency signal;

30 - frequency up-converting means for frequency up-converting the third lower  
frequency signal (S13) into the third radio frequency signal (S15) and for frequency up-  
converting the fourth lower frequency signal (S14) into the fourth radio frequency signal  
(S16).

9. Method for receiving at least a first radio frequency signal (S1) having a first frequency band (1) and a second radio frequency signal (S3) having a second frequency band (3) that is at least partly overlapping the first frequency band (1), the method comprising the steps of:

- 5 - frequency down-converting the at least first (S1) and second (S3) radio frequency signals into at least a first lower frequency signal (S2) and a second lower frequency signal (S4);
- sequentially multiplexing the at least first (S2) and second (S4) lower frequency signals into a frequency multiplexed signal (S5).

10

10. Method for transmitting at least a first radio frequency signal (S15) having a first frequency band (1) and a second radio frequency signal (S16) having a second frequency band (3) that is at least partly overlapping the first frequency band (1), the method comprising the steps of:

- 15 - sequentially multiplexing the at least first (S10) and a second signals (S11) into a frequency multiplexed signal (S12);
- demultiplexing the frequency multiplexed signal (S12) into at least a first (S13) and a second lower frequency signal (S14);
- frequency up-converting the first lower frequency signal (S13) into the first
- 20 radio frequency signal (S15) and the second lower frequency signal (S14) into the second radio frequency signal (S16).

1/3

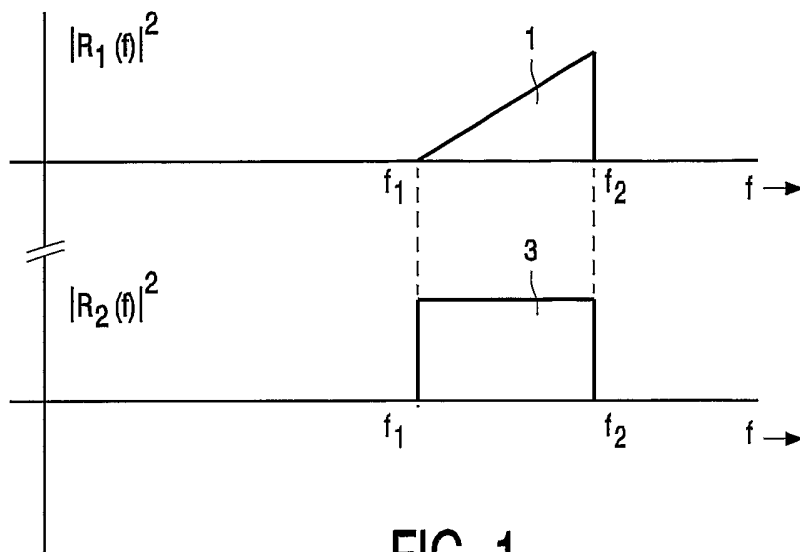

FIG. 1

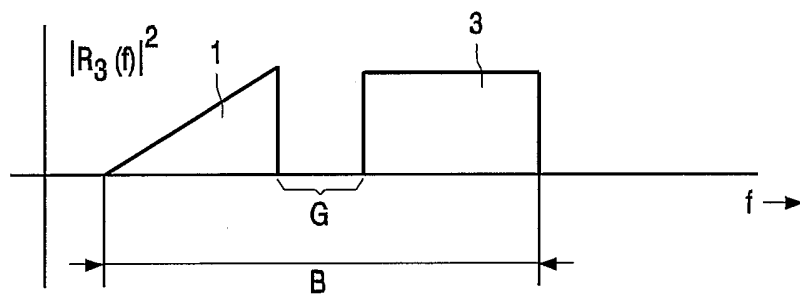

FIG. 2

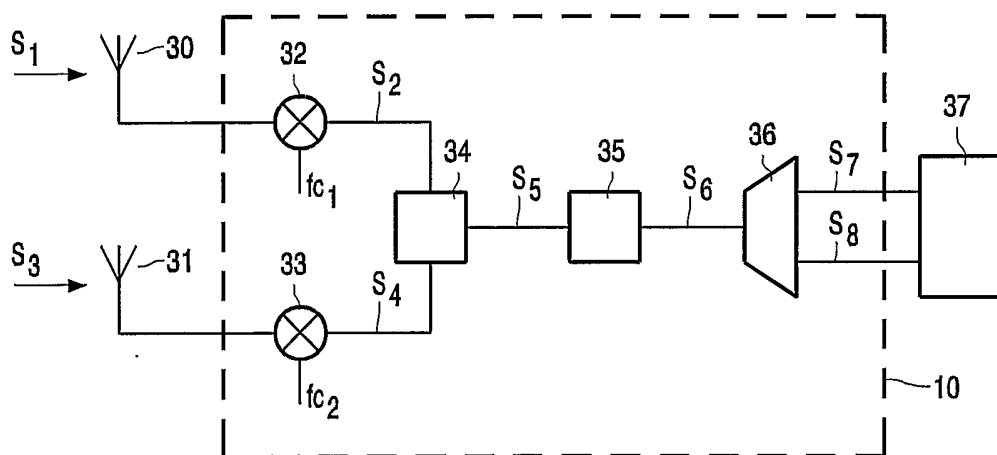

FIG. 3

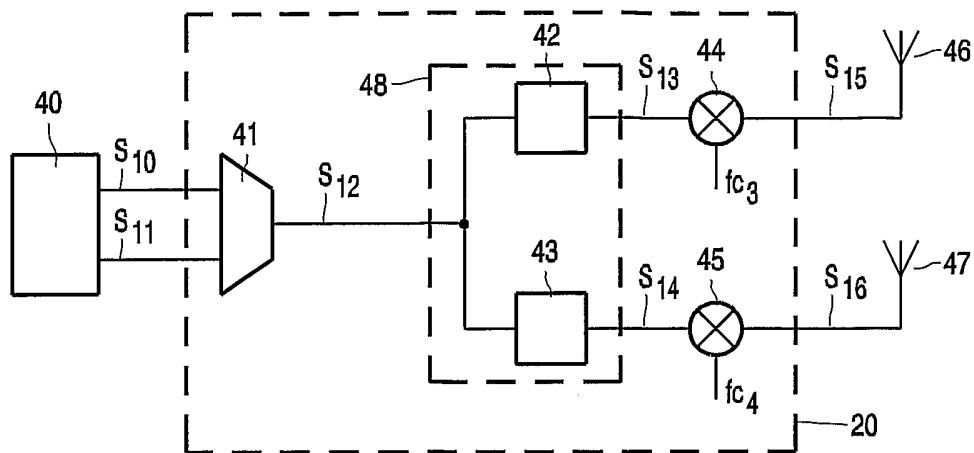

FIG. 4

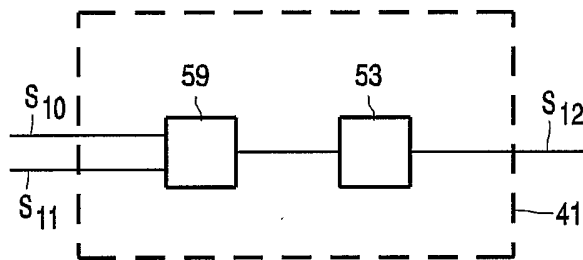

FIG. 4a

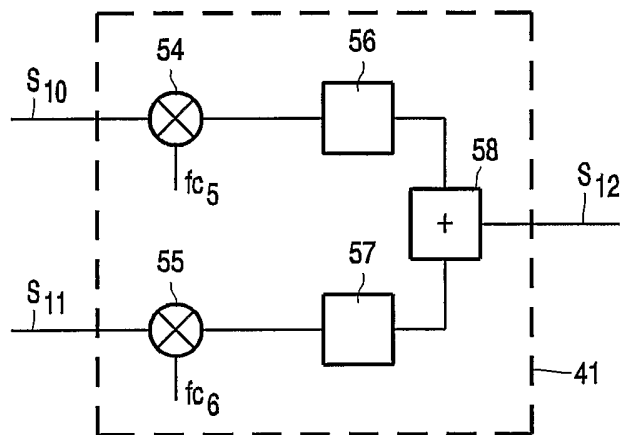

FIG. 4b

3/3

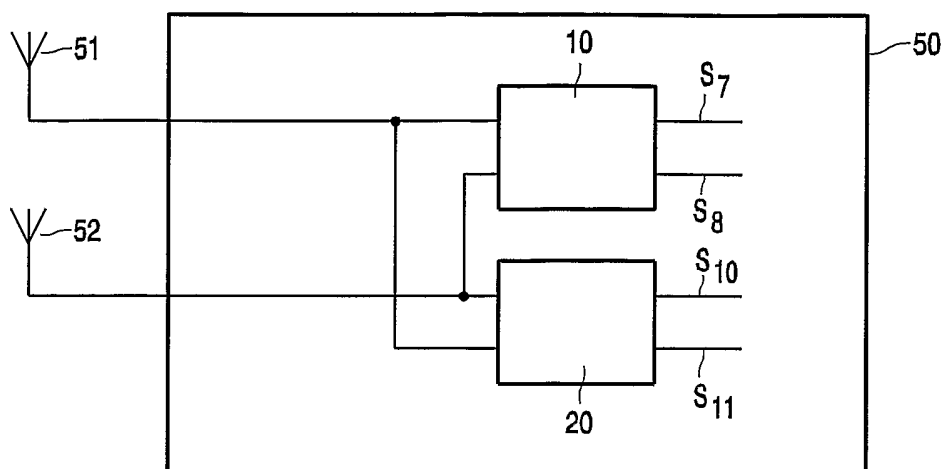

FIG. 5

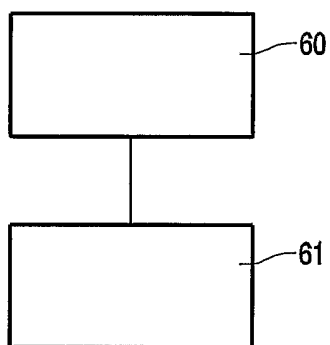

FIG. 6

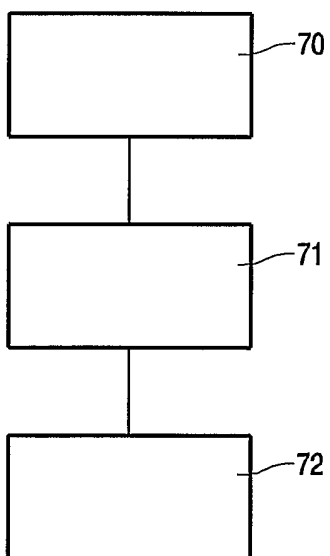

FIG. 7

INTERNATIONAL SEARCH REPORT

International Application No

PCT/IB2004/050776

A. CLASSIFICATION OF SUBJECT MATTER  
 IPC 7 H04Q7/30 H04B1/26

According to International Patent Classification (IPC) or to both national classification and IPC

B. FIELDS SEARCHED

Minimum documentation searched (classification system followed by classification symbols)  
 IPC 7 H04Q H04B H04L

Documentation searched other than minimum documentation to the extent that such documents are included in the fields searched

Electronic data base consulted during the international search (name of data base and, where practical, search terms used)

EPO-Internal, WPI Data

C. DOCUMENTS CONSIDERED TO BE RELEVANT

Category °	Citation of document, with indication, where appropriate, of the relevant passages	Relevant to claim No.
X	GB 2 296 611 A (MOTOROLA INC) 3 July 1996 (1996-07-03)	1,2,7,9
Y	abstract page 3, line 10 - page 5, line 12 figures 1,4a,4b	8
X	US 5 748 683 A (SMITH PAUL FIELDING ET AL) 5 May 1998 (1998-05-05)	1,3,7,9
Y	abstract column 2, lines 9-63 figure 1	8
	----- -/--	

Further documents are listed in the continuation of box C.

Patent family members are listed in annex.

° Special categories of cited documents :

- \*A\* document defining the general state of the art which is not considered to be of particular relevance
- \*E\* earlier document but published on or after the international filing date
- \*L\* document which may throw doubts on priority claim(s) or which is cited to establish the publication date of another citation or other special reason (as specified)
- \*O\* document referring to an oral disclosure, use, exhibition or other means
- \*P\* document published prior to the international filing date but later than the priority date claimed

- \*T\* later document published after the international filing date or priority date and not in conflict with the application but cited to understand the principle or theory underlying the invention
- \*X\* document of particular relevance; the claimed invention cannot be considered novel or cannot be considered to involve an inventive step when the document is taken alone
- \*Y\* document of particular relevance; the claimed invention cannot be considered to involve an inventive step when the document is combined with one or more other such documents, such combination being obvious to a person skilled in the art.
- \* & \* document member of the same patent family

Date of the actual completion of the international search

7 September 2004

Date of mailing of the international search report

15/09/2004

Name and mailing address of the ISA

European Patent Office, P.B. 5818 Patentlaan 2  
 NL - 2280 HV Rijswijk  
 Tel. (+31-70) 340-2040, Tx. 31 651 epo nl,  
 Fax: (+31-70) 340-3016

Authorized officer

Helms, J

## INTERNATIONAL SEARCH REPORT

International Application No  
PCT/IB2004/050776

C.(Continuation) DOCUMENTS CONSIDERED TO BE RELEVANT		
Category °	Citation of document, with indication, where appropriate, of the relevant passages	Relevant to claim No.
Y	CARSELLO R D ET AL: "IMT-2000 STANDARDS: RADIO ASPECTS" IEEE PERSONAL COMMUNICATIONS, IEEE COMMUNICATIONS SOCIETY, US, vol. 4, no. 4, 1 August 1997 (1997-08-01), pages 30-40, XP000696492 ISSN: 1070-9916 page 36, right-hand column - page 37, left-hand column figure 7	4-6,8,10
Y	WO 02/103926 A (QUALCOMM INC) 27 December 2002 (2002-12-27) paragraphs '1089! - '1095! figures 3,4a	4-6,8,10

## INTERNATIONAL SEARCH REPORT

Information on patent family members

International Application No

PCT/IB2004/050776

Patent document cited in search report		Publication date	Patent family member(s)	Publication date			
GB 2296611	A	03-07-1996	AU 686046 B2	29-01-1998			
			AU 4610696 A	24-07-1996			
			BR 9510374 A	02-06-1998			
			CA 2181807 A1	11-07-1996			
			CA 2206311 A1	11-07-1996			
			CN 1172566 A	04-02-1998			
			DE 19581533 C2	25-02-1999			
			DE 19581533 T0	05-06-1997			
			DE 19581876 T0	27-11-1997			
			EP 0800737 A1	15-10-1997			
			FI 963345 A	27-08-1996			
			FI 972748 A	25-06-1997			
			FR 2729022 A1	05-07-1996			
			GB 2311916 A ,B	08-10-1997			
			IL 116167 A	20-06-1999			
			JP 3530193 B2	24-05-2004			
			JP 9510074 T	07-10-1997			
			JP 10512114 T	17-11-1998			
			KR 203318 B1	15-06-1999			
			SE 520982 C2	16-09-2003			
			SE 9603089 A	17-09-1996			
			SE 9702156 A	29-08-1997			
			WO 9621292 A1	11-07-1996			
			WO 9621305 A1	11-07-1996			
			US 5659546 A	19-08-1997			
			US 5748683	A	05-05-1998	US 5579341 A	26-11-1996
						CA 2201352 A1	13-02-1997
DE 19680765 C1	31-05-2001						
FI 971122 A	17-03-1997						
FR 2737621 A1	07-02-1997						
GB 2308030 A ,B	11-06-1997						
SE 523421 C2	20-04-2004						
SE 9701116 A	29-05-1997						
US 5912927 A	15-06-1999						
WO 9705704 A1	13-02-1997						
AU 686046 B2	29-01-1998						
AU 4610696 A	24-07-1996						
AU 678124 B2	15-05-1997						
AU 5294796 A	24-07-1996						
BR 9506911 A	16-09-1997						
BR 9510374 A	02-06-1998						
CA 2182382 A1	11-07-1996						
CA 2206311 A1	11-07-1996						
CN 1142293 A ,B	05-02-1997						
CN 1172566 A	04-02-1998						
DE 19581527 C2	01-08-2002						
DE 19581527 T0	07-05-1997						
DE 19581876 T0	27-11-1997						
EP 0800737 A1	15-10-1997						
FI 963346 A	27-08-1996						
FI 972748 A	25-06-1997						
FR 2729026 A1	05-07-1996						
FR 2738428 A1	07-03-1997						
FR 2738429 A1	07-03-1997						
GB 2301990 A ,B	18-12-1996						
GB 2311916 A ,B	08-10-1997						
IL 115823 A	06-12-1998						



# INTERNATIONAL SEARCH REPORT

Information on patent family members

International Application No PCT/IB2004/050776
---

Patent document cited in search report	Publication date	Patent family member(s)	Publication date
US 5748683      A		JP 10512114 T	17-11-1998
		JP 10502513 T	03-03-1998
		KR 199316 B1	15-06-1999
		PL 316636 A1	03-02-1997
		SE 9603102 A	29-10-1996
		SE 9702156 A	29-08-1997
		TR 960822 A1	21-10-1996
		WO 9621305 A1	11-07-1996
		WO 9621288 A1	11-07-1996
		US 5602874 A	11-02-1997
		US 6167099 A	26-12-2000
		US 5754597 A	19-05-1998
		US 5818883 A	06-10-1998
		US 5812605 A	22-09-1998
	US 5854813 A	29-12-1998	
WO 02103926      A	27-12-2002	US 2003112880 A1	19-06-2003
		BR 0210417 A	20-07-2004
		EP 1400035 A1	24-03-2004
		WO 02103926 A1	27-12-2002