



(51) International Patent Classification:
A61F 2/44 (2006.01)

(21) International Application Number:
PCT/US2009/050575

(22) International Filing Date:
14 July 2009 (14.07.2009)

(25) Filing Language: English

(26) Publication Language: English

(30) Priority Data:
61/081,952 18 July 2008 (18.07.2008) US

(71) Applicant (for all designated States except US):
SPINALMOTION, INC. [US/US]; 201 San Antonio
Circle, Suite 115, Mountain View, CA 94040 (US).

(72) Inventors; and

(75) Inventors/Applicants (for US only): DE VILLIERS,
Malan [ZA/ZA]; 5 Touleir Place, 0050 Wapadrand (ZA).
JANSEN, Neville [ZA/ZA]; 170 Johan Rissik, Waterk-
loof, Pretoria (ZA).

(74) Agents: SHIMMICK, John, K. et al.; Townsend and
Townsend and Crew LLP, Two Embarcadero Center,
Eighth Floor, San Francisco, CA 94111-3834 (US).

(81) Designated States (unless otherwise indicated, for every
kind of national protection available): AE, AG, AL, AM,

AO, AT, AU, AZ, BA, BB, BG, BH, BR, BW, BY, BZ,
CA, CH, CL, CN, CO, CR, CU, CZ, DE, DK, DM, DO,
DZ, EC, EE, EG, ES, FI, GB, GD, GE, GH, GM, GT,
HN, HR, HU, ID, IL, IN, IS, JP, KE, KG, KM, KN, KP,
KR, KZ, LA, LC, LK, LR, LS, LT, LU, LY, MA, MD,
ME, MG, MK, MN, MW, MX, MY, MZ, NA, NG, NI,
NO, NZ, OM, PE, PG, PH, PL, PT, RO, RS, RU, SC, SD,
SE, SG, SK, SL, SM, ST, SV, SY, TJ, TM, TN, TR, TT,
TZ, UA, UG, US, UZ, VC, VN, ZA, ZM, ZW.

(84) Designated States (unless otherwise indicated, for every
kind of regional protection available): ARIPO (BW, GH,
GM, KE, LS, MW, MZ, NA, SD, SL, SZ, TZ, UG, ZM,
ZW), Eurasian (AM, AZ, BY, KG, KZ, MD, RU, TJ,
TM), European (AT, BE, BG, CH, CY, CZ, DE, DK, EE,
ES, FI, FR, GB, GR, HR, HU, IE, IS, IT, LT, LU, LV,
MC, MK, MT, NL, NO, PL, PT, RO, SE, SI, SK, SM,
TR), OAPI (BF, BJ, CF, CG, CI, CM, GA, GN, GQ, GW,
ML, MR, NE, SN, TD, TG).

Declarations under Rule 4.17:

— as to applicant's entitlement to apply for and be granted
a patent (Rule 4.17(ii))

Published:

— with international search report (Art. 21(3))

(54) Title: POSTERIOR PROSTHETIC INTERVERTEBRAL DISC

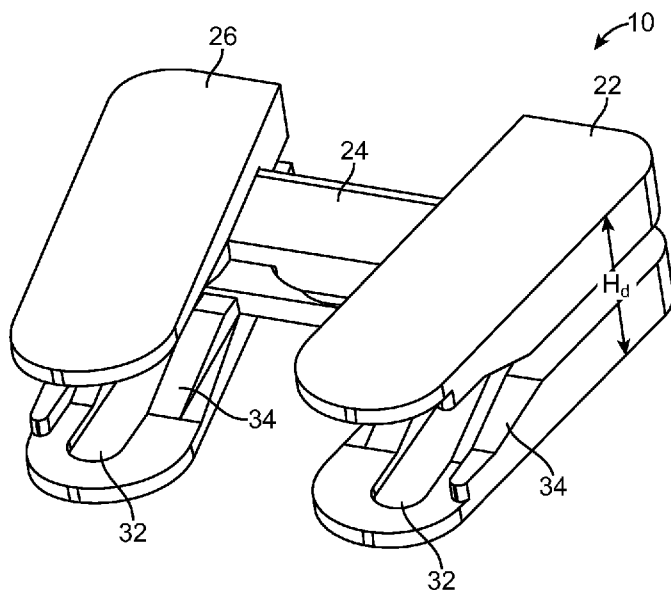

FIG. 6

(57) Abstract: A prosthetic intervertebral disc is formed of first and second end plates (12,14) sized and shaped to fit within an intervertebral space and to be implanted from the back of the patient, thereby decreasing the invasiveness of the procedure. The posterior approach provides for a smaller posterior surgical incision and avoids important blood vessels located anterior to the spine particularly for lumbar disc replacements. The first and second plates are each formed of first, second and third parts (22,24,26) are arranged in a first configuration in which the parts are axially aligned to form a low profile device appropriate for insertion through the small opening available in the TLIF or PLIF approaches described above. The three parts of both of the plates rotate and translate with respect to one another in situ to a second configuration or a deployed configuration in which the parts are axially unaligned with each other to provide a maximum coverage of the vertebral end plates for a minimum of insertion profile. Upon deployment of the disc, a height of the disc is increased.

WO 2010/009153 A1

POSTERIOR PROSTHETIC INTERVERTEBRAL DISC

CROSS-REFERENCES TO RELATED APPLICATIONS

5 [0001] This application claims priority to U.S. Provisional Application No. 61/081,952 filed July 18, 2008, entitled "POSTERIOR PROSTHETIC INTERVERTEBRAL DISC" the full disclosure of which is incorporated herein by reference.

BACKGROUND OF THE INVENTION

10 [0002] The present invention relates to medical devices and methods. More specifically, the invention relates to intervertebral prosthetic discs and methods of preserving limited motion upon removal of an intervertebral disc.

15 [0003] Back pain takes an enormous toll on the health and productivity of people around the world. According to the American Academy of Orthopedic Surgeons, approximately 80 percent of Americans will experience back pain at some time in their life. In the year 2000, approximately 26 million visits were made to physicians' offices due to back problems in the United States. On any one day, it is estimated that 5% of the working population in America is disabled by back pain.

20 [0004] One common cause of back pain is injury, degeneration and/or dysfunction of one or more intervertebral discs. Intervertebral discs are the soft tissue structures located between each of the thirty-three vertebral bones that make up the vertebral (spinal) column. Essentially, the discs allow the vertebrae to move relative to one another. The vertebral column and discs are vital anatomical structures, in that they form a central axis that supports the head and torso, allow for movement of the back, and protect the spinal cord, which passes through the vertebrae in proximity to the discs.

25 [0005] Discs often become damaged due to wear and tear or acute injury. For example, discs may bulge (herniate), tear, rupture, degenerate or the like. A bulging disc may press against the spinal cord or a nerve exiting the spinal cord, causing "radicular" pain (pain in one or more extremities caused by impingement of a nerve root). Degeneration or other damage to a disc may cause a loss of "disc height," meaning that the natural space between two
30 vertebrae decreases. Decreased disc height may cause a disc to bulge, facet loads to increase, two vertebrae to rub together in an unnatural way and/or increased pressure on certain parts

of the vertebrae and/or nerve roots, thus causing pain. In general, chronic and acute damage to intervertebral discs is a common source of back related pain and loss of mobility.

[0006] When one or more damaged intervertebral disc cause a patient pain and discomfort, surgery is often required. Traditionally, surgical procedures for treating intervertebral discs have involved discectomy (partial or total removal of a disc), with or without interbody fusion of the two vertebrae adjacent to the disc. When the disc is partially or completely removed, it is necessary to replace the excised disc material with natural bone or artificial support structures to prevent direct contact between hard bony surfaces of adjacent vertebrae. Oftentimes, pins, rods, screws, cages and/or the like are inserted between the vertebrae to act as support structures to hold the vertebrae and any graft material in place while the bones permanently fuse together.

[0007] A more recent alternative to traditional fusion is total disc replacement or TDR. TDR provides the ability to treat disc related pain without fusion provided by bridging bone, by using a movable, implantable, artificial intervertebral disc (or "disc prosthesis") between two vertebrae. A number of different artificial intervertebral discs are currently being developed. For example, U.S. Patent Application Publication Nos. 2005/0021146, 2005/0021145, and 2006/0025862, which are hereby incorporated by reference in their entirety, describe artificial intervertebral discs with mobile bearing designs. Other examples of intervertebral disc prostheses are the LINK[®] SB Charité disc (provided by DePuy Spine, Inc.) MOBIDISC[®] (provided by LDR Medical (www.ldrmedical.fr)), the BRYAN Cervical Disc (provided by Medtronic Sofamor Danek, Inc.), the PRODISC[®] or PRODISC-C[®] (from Synthes Stratec, Inc.), the PCM disc (provided by Cervitech, Inc.), and the MAVERICK[®] disc (provided by Medtronic Sofamor Danek).

[0008] A potential drawback of these known disc designs is that the prosthetic disc must be inserted from the anterior side of the patient. The anterior approach can be difficult and may require a vascular surgeon as the prosthetic disc passes near important blood vessels located anterior to the spine. Other currently available intervertebral disc prostheses usually have similar drawbacks, including invasiveness of the surgery and/or surgical skill and complexity.

[0009] Another prosthetic approach has been to fuse the vertebrae, for example with transforaminal lumbar interbody fusion (TLIF) surgery or posterior lumbar interbody fusion (PLIF) surgery. These procedures allow the surgery to be performed from the posterior without passing through the abdominal cavity and the associated drawbacks. The TLIF or

PLIF approaches involve passing through a much smaller space than an anterior approach and generally require at least partial removal of one or more facet joints to provide enough space for access to the disc space. It is this limitation on space that has until now prevented the design of a successful artificial disc for delivery by a TLIF or PLIF approach.

- 5 [0010] Therefore, a need exists for an improved disc for preserving motion and maintaining disc spacing between two vertebrae after removal of an intervertebral disc which can be delivered by a TLIF or PLIF approach. Ideally, such improved disc would be introduced in a small configuration and expanded in vivo to a larger configuration.

10 BRIEF SUMMARY OF THE INVENTION

[0011] Embodiments of the present invention provide a prosthetic intervertebral disc which is implanted from a PLIF or TLIF approach and is deployed from a small insertion configuration to a larger deployed configuration in vivo.

- 15 [0012] In accordance with one aspect of the invention, a prosthetic intervertebral disc includes first and second end plates sized and shaped to fit within an intervertebral space, each end plate having a vertebral contacting surface and an inner surface and a first bearing surface on an inner surface of the first end plate and a second bearing surface on an inner surface of the second end plate. The first and second bearing surfaces are arranged to allow articulation and rotation between the first and second plates. The first and second plates are
20 each formed of first, second and third parts having a first configuration in which the parts are axially aligned to a second configuration in which the parts are axially unaligned with each other. The first and second plates are deployed in situ from the first configuration to the second configuration by both rotation and sliding of the parts over one another. The deployment from the first configuration to the second configuration increases a height of the
25 disc.

- [0013] In accordance with another embodiment of the invention, a prosthetic intervertebral disc includes first and second end plates sized and shaped to fit within an intervertebral space, each end plate having a vertebral contacting surface and an inner surface, a first bearing surface on an inner surface of the first end plate and a second bearing surface on an inner
30 surface of the second end plate, the first and second bearing surfaces opposed to one another, and a mobile core configured to be received between the first and second bearing surfaces and arranged to allow articulation and rotation between the first and second plates. The first

and second plates are each formed of first, second and third parts having a first configuration in which the parts are axially aligned and a second configuration in which the parts are axially unaligned with each other. A track is formed in the first and second end plates. The track is configured to allow the mobile core to move from a first position outside of the bearing surfaces to a position between the bearing surfaces, wherein the movement of the mobile core from the first position to the second position increases a height of the disc.

[0014] In accordance with a further aspect of the invention, a method of deploying a prosthetic intervertebral disc comprises the steps of: providing a prosthetic intervertebral disc having first and second end plates each having a vertebral contacting surface and an inner surface, a first bearing surface on an inner surface of the first end plate and a second bearing surface on an inner surface of the second end plate, the first and second bearing surfaces arranged to allow articulation and rotation between the first and second plates, wherein the first and second plates are each formed of first, second and third parts; inserting the intervertebral disc between two vertebrae in a configuration in which the first, second and third parts of each of the plates are axially aligned; and deploying the first and second plates *in situ* from the first configuration to a second configuration in which the parts are axially unaligned with each other by both rotation and sliding of the parts over one another, wherein the deployment from the first configuration to the second configuration increases a height of the disc. In accordance with an additional aspect of the invention, a method of deploying a prosthetic intervertebral disc includes the steps of: providing a prosthetic intervertebral disc comprising first and second end plates and a mobile core arranged to allow articulation and rotation between the first and second plates, wherein the first and second plates are each formed of first, second and third parts; inserting the intervertebral disc between two vertebrae in a configuration in which the first, second and third parts of each of the plates are substantially axially aligned; deploying the first and second plates *in situ* from the first configuration to a second configuration in which the parts are axially unaligned with each other; and moving the mobile core along a track between the end plates, wherein the movement of the mobile core from the first position to the second position increases a height of the disc.

BRIEF DESCRIPTION OF THE DRAWINGS

[0015] FIG. 1 is a perspective view of a posterior prosthetic intervertebral disc in a narrow insertion configuration;

[0016] FIG. 2 is a side view of the disc of FIG. 1;

[0017] FIG. 3 is a top view of the disc of FIG. 1;

[0018] FIG. 4 is a side cross sectional view of the disc of FIG. 1 taken along the line 4-4 of FIG. 3;

5 [0019] FIG. 5 is a cross sectional view of the disc of FIG. 1 taken along the line 5-5 of FIG. 2;

[0020] FIG. 6 is a perspective view of the disc of FIG. 1 in an expanded deployed configuration;

[0021] FIG. 7 is a top view of the deployed disc of FIG. 6;

10 [0022] FIG. 8 is a top view of an alternative embodiment of a posterior prosthetic intervertebral disc in a partially deployed configuration;

[0023] FIG. 9 is a perspective view of the disc of FIG. 8;

[0024] FIG. 10 is a side view of the disc of FIG. 8;

15 [0025] FIG. 11 is a perspective view of the disc of FIG. 8 with the core moving along a track from the position of FIG. 8 to the fully deployed position of FIG. 12; and

[0026] FIG. 12 is a perspective view of the disc of FIG. 8 with the core in a fully deployed position.

DETAILED DESCRIPTION OF THE INVENTION

20 [0027] The present invention provides an implanted intervertebral disc assembly which both restores motion and can be implanted from the back of the patient, thereby decreasing the invasiveness of the procedure. The posterior approach provides for a smaller posterior surgical incision and avoids important blood vessels located anterior to the spine particularly for lumbar disc replacements. The intervertebral discs described herein are designed to be
25 suitable for either a PLIF or TLIF approach to the spine. These approaches require insertion of a device with a small insertion profile which can be expanded or assembled in vivo into a complete disc assembly.

[0028] PLIF stands for Posterior Lumbar Interbody Fusion. In the PLIF approach to the spine, the vertebrae are reached through an incision in the patient's back (posterior). The PLIF

procedure involves forming a 3-6 inch incision in the patient's back and retracting the spinal muscles to allow access to the vertebral disc. The surgeon then carefully removes the lamina (laminectomy) to be able to see and access the nerve roots. The facet joints, which lie directly over the nerve roots, may be trimmed to allow more room for the nerve roots. Depending on the amount of space available, $\frac{1}{4}$ to $\frac{1}{2}$ of the facets may be removed. The surgeon then removes some or all of the affected disc and surrounding tissue. Once the disc space is prepared, hardware, such as an intervertebral disc, is inserted into the disc space. The space available for insertion of the intervertebral disc can vary depending on the patient, but generally the opening has a width and height of about 1 cm which with distraction can form a slightly larger opening.

[0029] TLIF stands for Transforaminal Lumbar Interbody Fusion. The TLIF has recently gained popularity as a surgical access to the lumbar spine and provides some potential advantages over the PLIF approach. The TLIF technique involves approaching the spine in a similar manner as the PLIF approach but more from the side of the spinal canal through a midline incision in the patient's back. This approach greatly reduces the amount of surgical muscle dissection and minimizes the nerve manipulation required to access the vertebrae, discs and nerves. The TLIF approach is generally less traumatic to the spine, is safer for the nerves, and allows for minimal access. However, the TLIF involves the removal of at least one and possibly both facets.

[0030] FIG. 1 illustrates a prosthetic intervertebral disc formed of first and second end plates 12, 14 sized and shaped to fit within an intervertebral space. Each plate 12, 14 has a vertebral contacting outer surface 16 and an inner surface carrying first and second bearing surfaces 18, 20 (shown in FIGS. 4 and 5). The first bearing surface 18 in the embodiment of FIG. 1 is a concave bearing surface while the second bearing surface 20 is a mating convex bearing surface. Together the bearing surfaces 18, 20 form a ball and socket joint arranged to allow articulation and rotation between the first and second plates 12, 14.

[0031] The first and second plates 12, 14 are each formed of first, second and third parts 22, 24, 26. The three parts 22, 24, 26 have a first configuration, shown in FIG. 1 in which the parts are axially aligned to form a low profile device appropriate for insertion through the small opening available in the TLIF or PLIF approaches described above. Preferably, the undeployed configuration of FIG. 1 has a height less than about 10 mm and a width less than about 12 mm. The three parts 22, 24, 26 of both of the plates 12, 14 rotate and translate with

respect to one another *in situ* to a second configuration or a deployed configuration in which the parts are axially unaligned with each other. In the deployed configuration, as shown in FIGS. 6 and 7, the three parts form a substantially H-shaped configuration which provides a maximum coverage of the vertebral end plates for a minimum of insertion profile. As the three parts 22, 24, 26 translate with respect to one another to the deployed configuration a height of the disc is increased in a manner which will be described in detail below.

[0032] The bone integration surfaces 16 of the disc 10 have been shown as flat surfaces for ease of illustration. The outer vertebral body contacting surface 16 may take on any of the configurations known in the art. Oftentimes, the outer surfaces 16 will include one or more surface features and/or materials to enhance attachment of the disc 10 to vertebral bone. For example, the outer surfaces 16 may be machined to have serrations, teeth or other surface features for promoting adhesion of the plates 12, 14 to a vertebra. In one embodiment, serrations are provided on the outer surfaces 16. The serrations can be pyramid shaped serrations extending in mutually orthogonal directions, but other geometries of serrations or other features including teeth, grooves, ridges, pins, barbs and combinations thereof would also be useful. When the bone integration structures are ridges, teeth, barbs or similar structures, they may be angled to ease insertion and prevent migration. The outer surfaces may include other fixation means inserted after deployment of the disc 10, including one or more fins, pins, or screws. In one embodiment, one or more fins are provided on the last of the three parts to enter the disc space. Optionally, additional fins may be provided that are inserted after the disc is positioned by sliding the fin(s) into one or more slots in the endplates.

[0033] The outer surfaces 16 may be provided with a rough microfinish formed by blasting with aluminum oxide microparticles or the like to improve bone integration. In some embodiments, the outer surface 16 may also be titanium plasma sprayed or HA coated to further enhance attachment of the outer surface to vertebral bone.

[0034] The disc 10 may be deployed with the aid of various instruments including one or more distracters, sizing guides, placement instruments and deployment instruments. The deployment instruments can be fixed to the ends of the disc 10 in the insertion configuration shown in FIG. 1 by a connection means, such as a quick connect or a threaded coupling. The placement and deployment instruments generally include at least two instruments with one instrument inserted through each of the two openings formed at the posterior side of the disc

space on either side of the spine. Referring now to FIG. 3, the sequence of deployment of the disc 10 includes rotation of the first and third parts 22, 26 with respect to the second part 24 in the direction of the arrows A, followed by sliding of the second part 24 along first and third parts in the direction of the arrow B to form the deployed configuration shown in FIGS.

5 6 and 7.

[0035] The disc 10 includes cylindrical pegs 30 on opposite ends of the second parts 24 which fit into channels 32 on the first and third parts 22, 26 to allow first rotation and then translation of the second part along the first and third parts. The rotation of the disc 10 from the substantially linear arrangement of FIGS. 1-3 to a substantially U-shaped arrangement
10 (not shown) can be caused by contact of a leading end of the inserted disc with an annulus of the natural disc. The U-shaped configuration is then converted to the final H-shaped configuration by pulling the second part 24 posteriorly in the direction of the arrow B. The sliding of the second or center part 24 along the channels 32 causes the disc space to be distracted, i.e. the height of the disc increases from an initial height H_i , shown in FIG. 2 to a
15 deployed height H_d , shown in FIG. 6. This distraction or separation of the end plates is provided by ramps 34 which lie along each side of the channel 32 in the first and third parts 22, 26. The deployed height H_d is preferably between 1.3 and 2 times the initial height H_i . In one example, the deployed height H_d is about 1.5 times the initial height H_i and provides a final deployed disc configuration shown in FIG. 6 which is significantly higher than the
20 height of the access opening provided by the posterior PLIF or TLIF approach.

[0036] Another embodiment of a posterior prosthetic intervertebral disc 100 is shown in FIGS. 8-12. The prosthetic disc 100 includes first and second end plates 112, 114 sized and shaped to fit within an intervertebral space, each end plate having a vertebral contacting surface 116 and an opposite inner surface including a bearing surface 118. The disc 100
25 includes a mobile core 120 which in a deployed configuration is positioned between the opposing bearing surfaces 118 to provide a mobile core articulating disc design. As in the embodiment of FIG. 1, each of the plates 112, 114 are formed of first, second and third parts 122, 124, 126. The three parts of the plates have a first configuration for insertion of the disc 100 through a small posterior keyhole into the disc space. In the first configuration (not
30 shown) the three parts 122, 124, 126 are substantially axially aligned. The after insertion, the three parts 122, 124, 126 are rotated by pivoting on interconnecting posts 130 to a second configuration in which the parts are axially unaligned with each other and arranged with the

first and third parts 122, 126 at an angle of about 20-90 degrees with respect to one another, preferably about 70-85 degrees.

[0037] The mobile core 120 includes opposite convex bearing surfaces arranged to be received between the first and second bearing surfaces 118 of the plates to allow articulation, rotation and some translation between the first and second plates. As shown in FIGS. 8-10, for insertion of the disc 100 into the disc space, the core 120 is positioned in a seat 132 formed between the first parts 122 at one end of the first parts. After insertion of the disc 100 into the disc space, the core 120 is advanced along a track 134, shown in FIG. 11 from the seat 132 to a final deployed position between the bearing surfaces 118 of the plates. FIG. 12 shows the core 120 seated between the bearing surfaces 118. The bearing surfaces 118 may include one or more core retaining features, such as a retaining ring or other peripheral retaining features. As can be seen in FIG. 11, the movement of the mobile core 130 from the first position in the seat 132 to the second position between the bearing surfaces 118 distracts the plates 112, 114 away from one another and increases a height of the disc 100 from an initial height H_i , shown in FIG. 10 to a deployed height H_d shown in FIG. 12.

[0038] The procedure for replacing a natural intervertebral disc with the artificial intervertebral discs 10, 100 includes using a PLIF or TLIF approach to the spine, by forming a 3-6 inch incision in the patient's back and retracting the spinal muscles to allow access to the vertebral disc. The surgeon then carefully removes the lamina (laminectomy) to be able to see and access the nerve roots. The disc space is then entered through a preexisting opening or through an opening formed by cutting away a portion of or an entire one or more facet. Those skilled in the art will understand the procedure of preparing the disc space and implanting the disc which is summarized herein. A far posterio-lateral minimally invasive approach can be used so as to allow for the minimum of facet removal such that the facet joints remain substantially intact. The surgeon then removes some or all of the affected disc and surrounding tissue. Once the disc space is prepared the intervertebral disc is inserted into the disc space in the insertion configuration in which the first, second and third parts are aligned. The space available for insertion of the intervertebral disc can vary depending on the patient, but generally the opening has a width and height of about 1 cm which with distraction can form a slightly larger opening, i.e. about 1 cm by 1.2 cm. The deployment of the discs 10, 100 can be performed through a single posterior opening, or preferably, through two posterior openings to allow the surgeon better access to deploy the disc. In one

embodiment, one of the two openings is used for insertion of the disc while the other opening is used for a distraction instrument and/or other deployment instruments.

[0039] The upper and lower plates 12, 14, 112, 114 may be constructed from any suitable metal, alloy or combination of metals or alloys, such as but not limited to cobalt chrome alloys, titanium (such as grade 5 titanium), titanium based alloys, tantalum, nickel titanium alloys, stainless steel, and/or the like. They may also be formed of ceramics, biologically compatible polymers including PEEK, UHMWPE, PLA or fiber reinforced polymers. The plates 12, 14, 112, 114 may be formed of a one piece construction or may be formed of more than one piece, such as different materials coupled together.

[0040] The core 130 can be made of low friction materials, such as titanium, titanium nitrides, other titanium based alloys, tantalum, nickel titanium alloys, stainless steel, cobalt chrome alloys, ceramics, or biologically compatible polymer materials including PEEK, UHMWPE, PLA or fiber reinforced polymers. High friction coating materials can also be used.

[0041] Different materials may be used for different parts of the disc 10 to optimize imaging characteristics. PEEK plates may also be coated with titanium plasma spray or provided with titanium screens for improved bone integration. Other materials and coatings can also be used such as titanium coated with titanium nitride, aluminum oxide blasting, HA (hydroxylapatite) coating, micro HA coating, and/or bone integration promoting coatings.

Any other suitable metals or combinations of metals may be used as well as ceramic or polymer materials, and combinations thereof. Any suitable technique may be used to couple materials together, such as snap fitting, slip fitting, lamination, interference fitting, use of adhesives, welding and the like.

[0042] Although the present invention has been described as having a ball in socket design (disc 10) or a mobile core design (disc 100), the articulation surfaces may be varied to take on any of the different articulation designs known in the art. For example, the disc 10 may use a mobile bearing design in place of the ball and socket articulation. In one alternative embodiment of the invention non-symmetrically shaped bearing surfaces are used to tailor the articulation of the disc to the anatomy. In one example, the bearing surfaces are arranged to allow a maximum of 12 degrees of motion in flexion, a maximum of 8 degrees in extension and a maximum of 8 degrees in each direction of lateral bending. This configuration is useful

particularly in the lumbar spine where the average range of motion of the various segments is larger in flexion than in extension or lateral bending.

5 [0043] Although the core 130 of FIG. 8 has been shown as circular in cross section with spherically shaped bearing surfaces, other shapes may be used including oval, elliptical, or kidney bean shaped. The circular shaped core does not limit rotational motion between the plates. The non-circular shaped cores can be used to limit rotational motion between the upper and lower plates 112, 113. When the core 130 is formed of a polymer such as PEEK which is invisible under radiographic imaging, it may be desirable to have a radiographic marker imbedded within the core.

10 [0044] While the exemplary embodiments have been described in some detail, by way of example and for clarity of understanding, those of skill in the art will recognize that a variety of modifications, adaptations, and changes may be employed. Hence, the scope of the present invention should be limited solely by the appended claims.

WHAT IS CLAIMED IS:

- 1 1. A prosthetic intervertebral disc comprising:
2 first and second end plates sized and shaped to fit within an intervertebral
3 space, each end plate having a vertebral contacting surface and an inner surface;
4 a first bearing surface on an inner surface of the first end plate and a second
5 bearing surface on an inner surface of the second end plate, the first and second bearing
6 surfaces arranged to allow articulation and rotation between the first and second plates;
7 wherein the first and second plates are each formed of first, second and third
8 parts having a first configuration in which the parts are axially aligned and a second
9 configuration in which the parts are axially unaligned with each other, the first and second
10 plates deployed *in situ* from the first configuration to the second configuration by both
11 rotation and sliding of the parts over one another, and wherein the deployment from the first
12 configuration to the second configuration increases a height of the disc.
- 1 2. The disc of Claim 1, wherein the first, second and third parts are
2 arranged with the second part interconnecting the first and third parts.
- 1 3. The disc of Claim 2, wherein opposite ends of the second part are
2 arranged to slide along the first and third parts during deployment.
- 1 4. The disc of Claim 3, wherein the opposite ends of the second part slide
2 in elongated tracks on the second and third parts to increase the height of the disc in a
3 direction perpendicular to the direction of sliding.
- 1 5. The disc of Claim 1, wherein the first bearing surface and the second
2 bearing surface comprise a ball and socket articulating joint.
- 1 6. The disc of Claim 1, wherein the first bearing surface and the second
2 bearing surface comprise three piece a mobile core articulating joint.
- 1 7. The disc of Claim 1, wherein first configuration comprises a
2 substantially linear arrangement.
- 1 8. The disc of Claim 7, wherein the second configuration comprises a
2 substantially H-shaped arrangement.

1 9. The disc of Claim 7, wherein the disc in the first configuration has a
2 height and width of less than 12 mm.

1 10. A prosthetic intervertebral disc comprising:
2 first and second end plates sized and shaped to fit within an intervertebral
3 space, each end plate having a vertebral contacting surface and an inner surface;
4 a first bearing surface on an inner surface of the first end plate and a second
5 bearing surface on an inner surface of the second end plate, the first and second bearing
6 surfaces opposed to one another;

7 wherein the first and second plates are each formed of first, second and third
8 parts having a first configuration in which the parts are substantially axially aligned and a
9 second configuration in which the parts are axially unaligned with each other;

10 a mobile core configured to be received between the first and second bearing
11 surfaces and arranged to allow articulation and rotation between the first and second plates;
12 and

13 a track formed in the first and second end plates, the track configured to allow
14 the mobile core to move from a first position outside of the bearing surfaces to a position
15 between the bearing surfaces, wherein the movement of the mobile core from the first
16 position to the second position increases a height of the disc.

1 11. The disc of Claim 10, wherein the first, second and third parts are
2 arranged with the second part interconnecting the first and third parts.

1 12. The disc of Claim 11, wherein the first and third parts are arranged to
2 pivot on opposite ends of the second part during deployment.

1 13. The disc of Claim 10, wherein first configuration comprises a
2 substantially linear arrangement.

1 14. The disc of Claim 13, wherein the second configuration comprises a
2 substantially H-shaped arrangement.

1 15. The disc of Claim 10, wherein the disc in the first configuration has a
2 height and width of less than 12 mm.

1 16. The disc of Claim 12, wherein the disc in the second configuration has
2 a height of at least 1.5 times a height in the first configuration.

1 17. The disc of Claim 1, wherein the disc in the second configuration has a
2 height of at least 1.5 times a height in the first configuration.

1 18. A method of deploying a prosthetic intervertebral disc, the method
2 comprising:

3 providing a prosthetic intervertebral disc having first and second end plates
4 each having a vertebral contacting surface and an inner surface, a first bearing surface on an
5 inner surface of the first end plate and a second bearing surface on an inner surface of the
6 second end plate, the first and second bearing surfaces arranged to allow articulation and
7 rotation between the first and second plates, wherein the first and second plates are each
8 formed of first, second and third parts;

9 inserting the intervertebral disc between two vertebrae in a configuration in
10 which the first, second and third parts of each of the plates are axially aligned; and

11 deploying the first and second plates *in situ* from the first configuration to a
12 second configuration in which the parts are axially unaligned with each other by both rotation
13 and sliding of the parts over one another, wherein the deployment from the first configuration
14 to the second configuration increases a height of the disc.

1 19. The method of Claim 18, wherein the first, second and third parts are
2 arranged with the second part interconnecting the first and third parts.

1 20. The method of Claim 19, wherein opposite ends of the second part
2 slide along the first and third parts during deployment.

1 21. The method of Claim 20, wherein the opposite ends of the second part
2 slide in elongated tracks on the second and third parts to increase the height of the disc in a
3 direction perpendicular to the direction of sliding.

1 22. A method of deploying a prosthetic intervertebral disc, the method
2 comprising:

3 providing a prosthetic intervertebral disc comprising first and second end
4 plates and a mobile core arranged to allow articulation and rotation between the first and

5 second plates, wherein the first and second plates are each formed of first, second and third
6 parts;

7 inserting the intervertebral disc between two vertebrae in a configuration in
8 which the first, second and third parts of each of the plates are substantially axially aligned;

9 deploying the first and second plates *in situ* from the first configuration to a
10 second configuration in which the parts are axially unaligned with each other; and

11 moving the mobile core along a track between the end plates, wherein the
12 movement of the mobile core from the first position to the second position increases a height
13 of the disc.

1 23. The method of Claim 22, wherein the track is formed in inner surfaces
2 of the first and second end plates and is configured to allow the mobile core to move from a
3 first position outside of bearing surfaces of the end plates to a position between the bearing
4 surfaces of the end plates.

1 24. The method of Claim 22, wherein the second configuration comprises
2 a substantially H-shaped arrangement.

1 25. The method of Claim 22, wherein the disc in the first configuration has
2 a height and width of less than 12 mm.

1 26. The method of Claim 22, wherein the disc in the second configuration
2 has a height of at least 1.5 times a height in the first configuration.

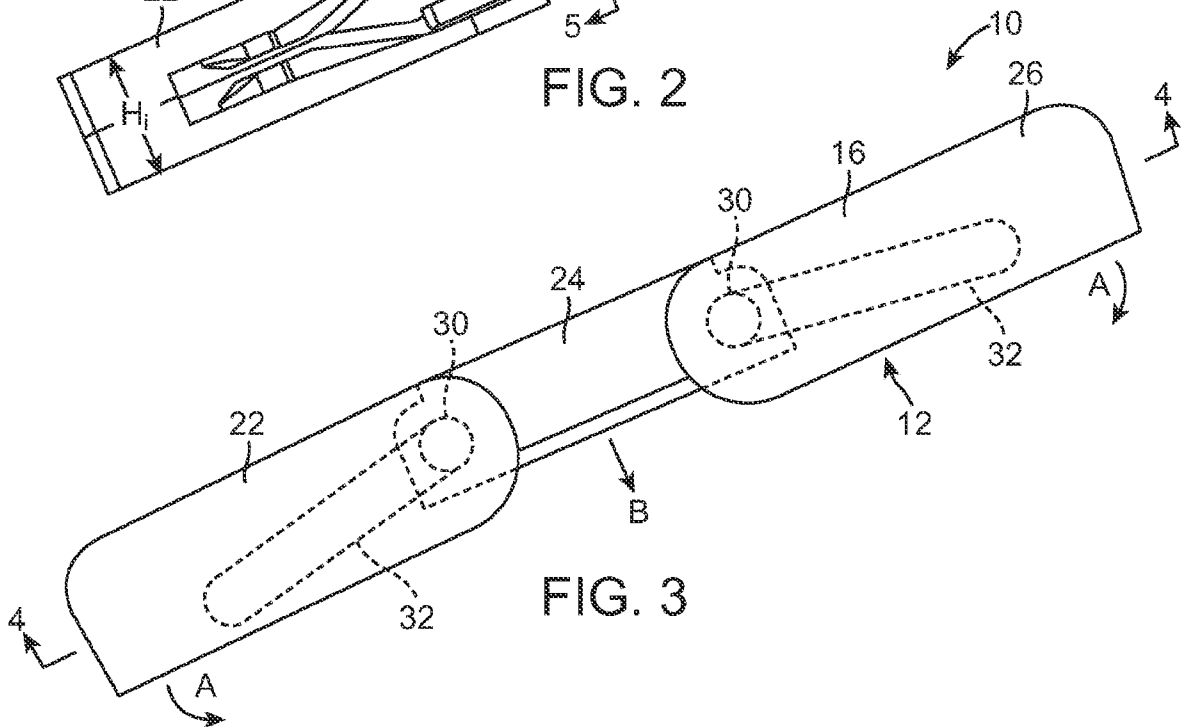
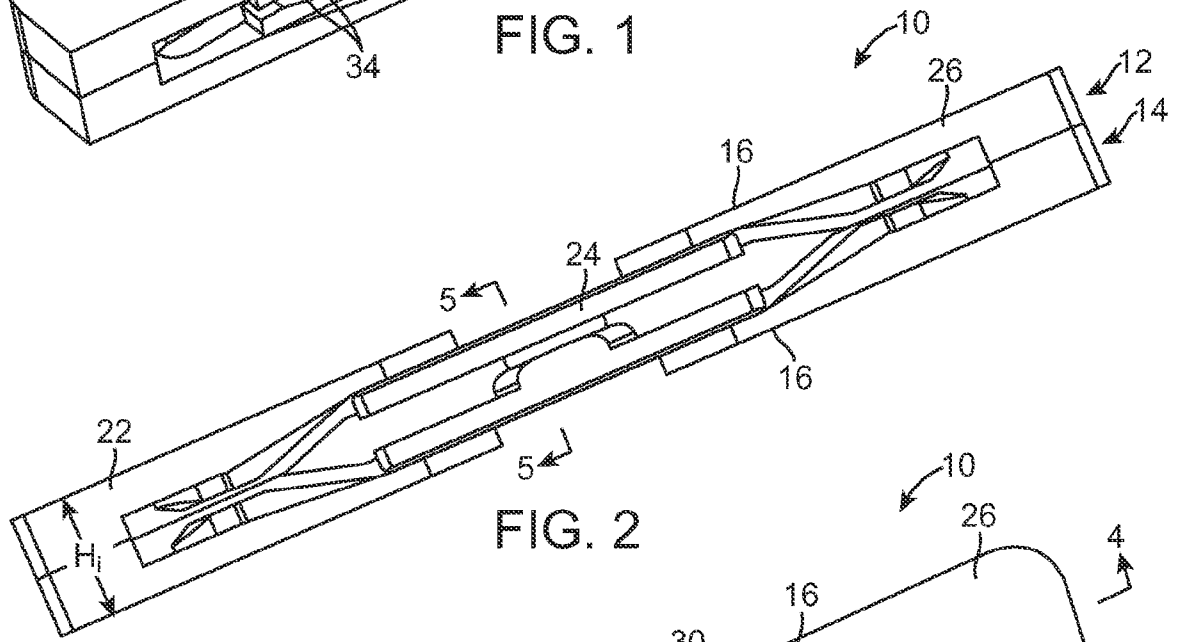
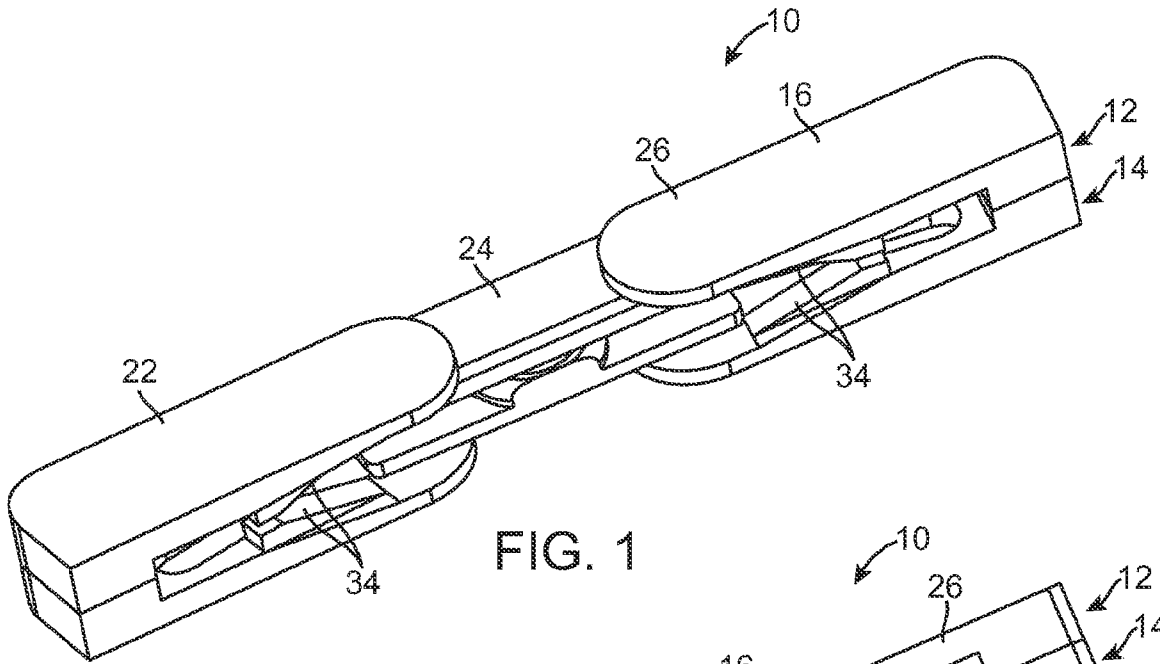

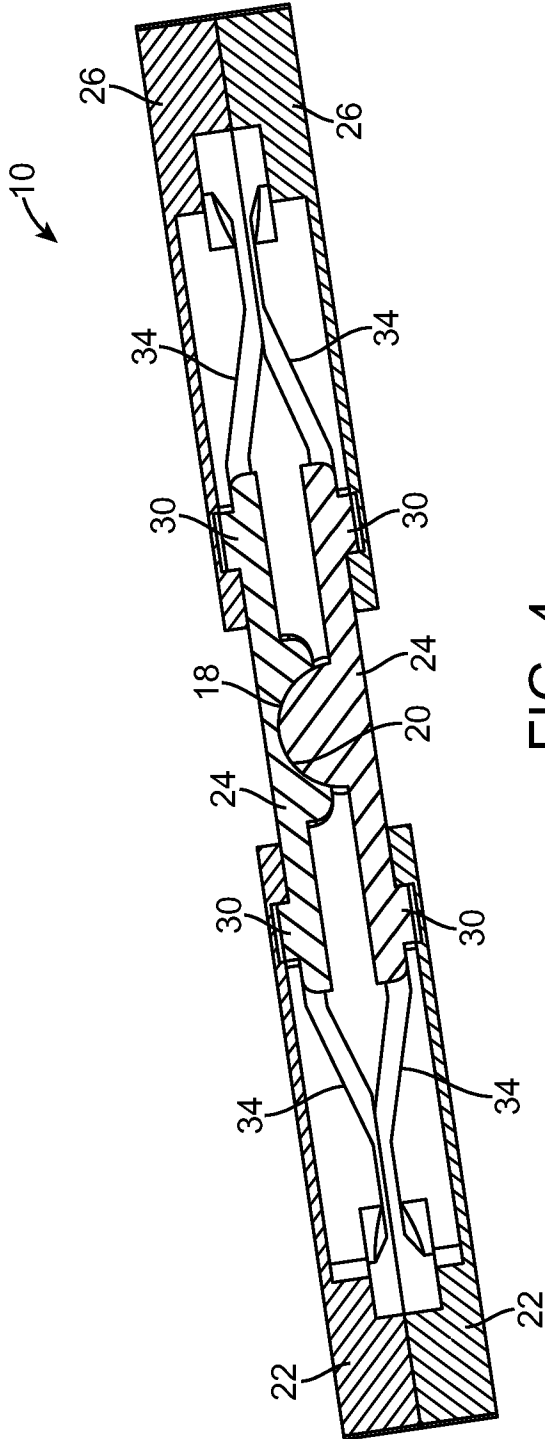

FIG. 4

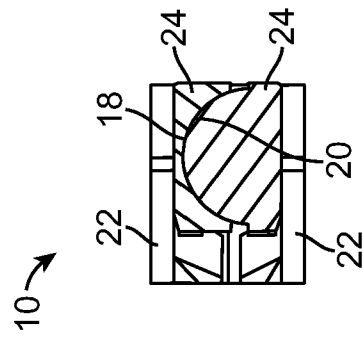

FIG. 5

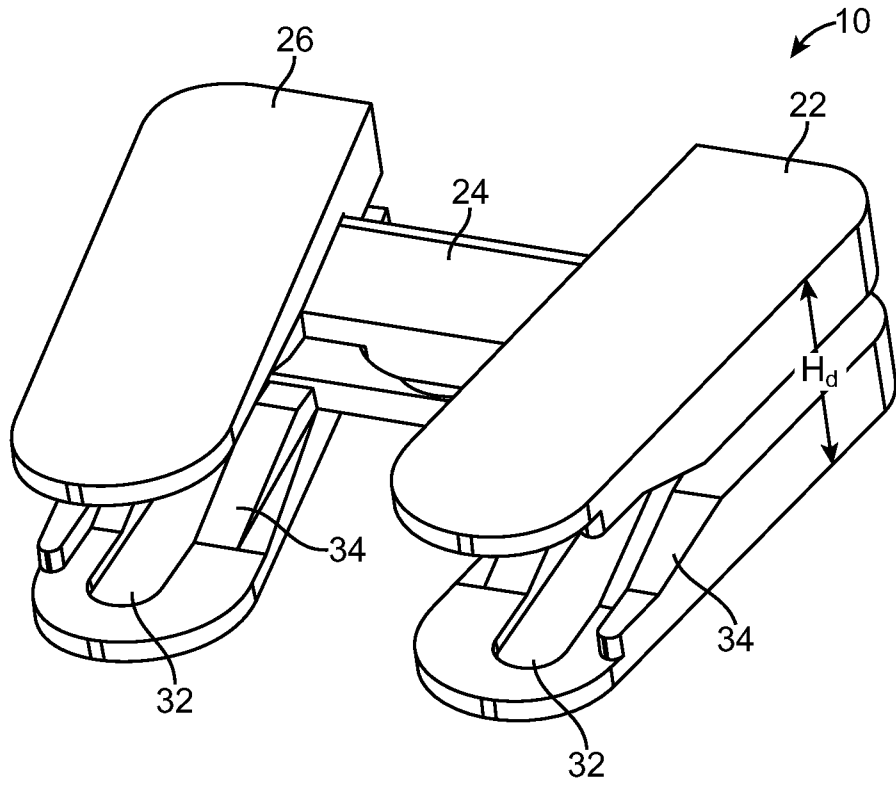

FIG. 6

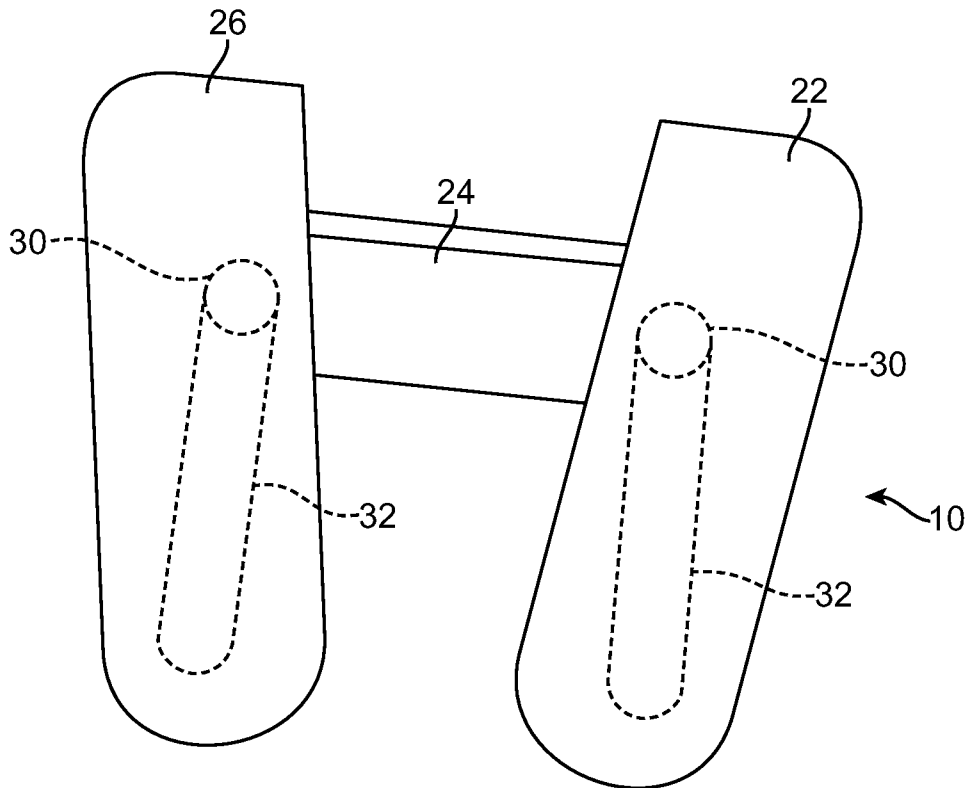

FIG. 7

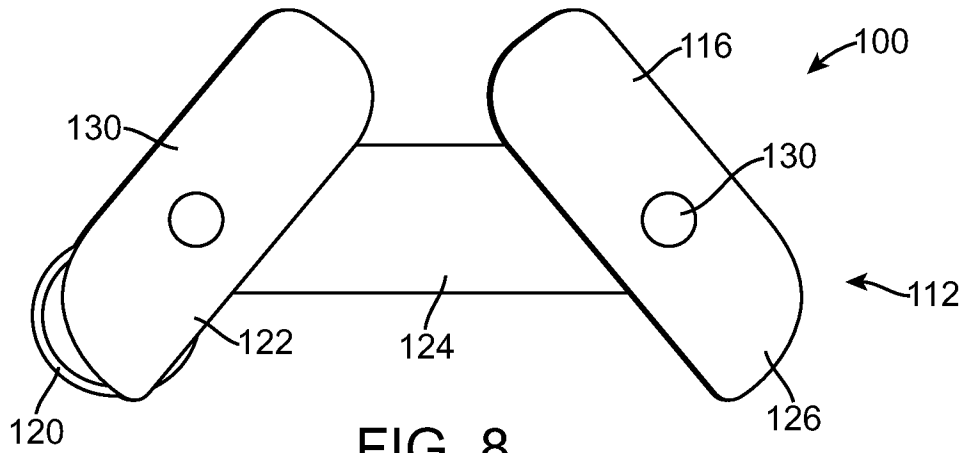

FIG. 8

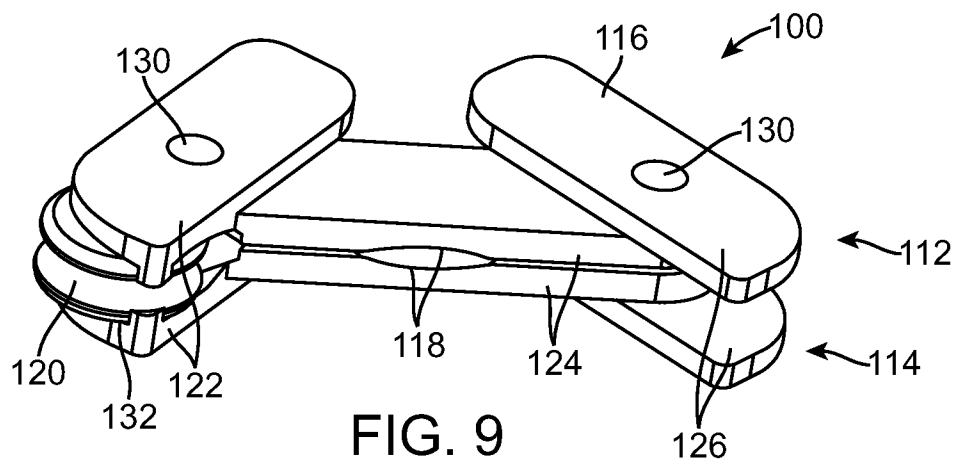

FIG. 9

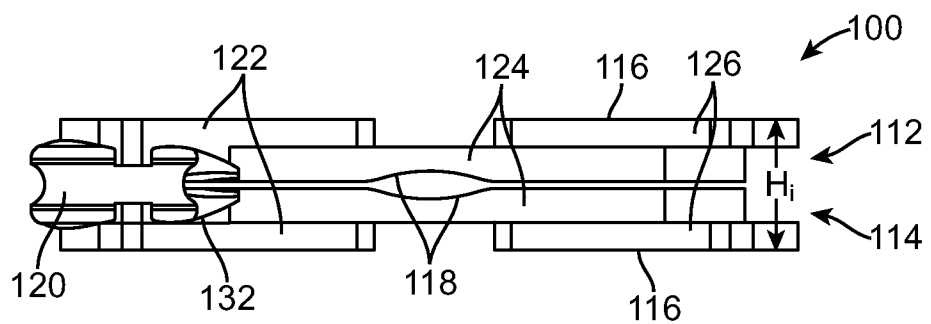
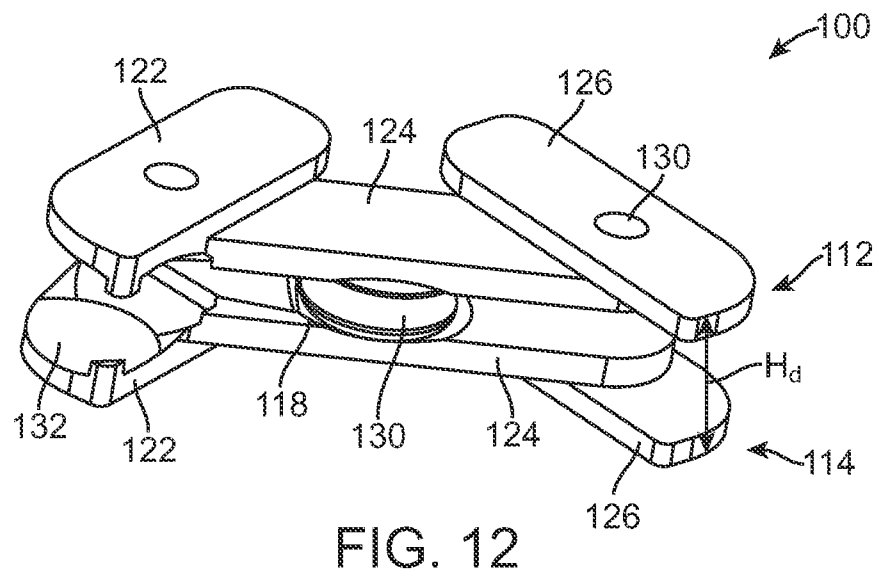
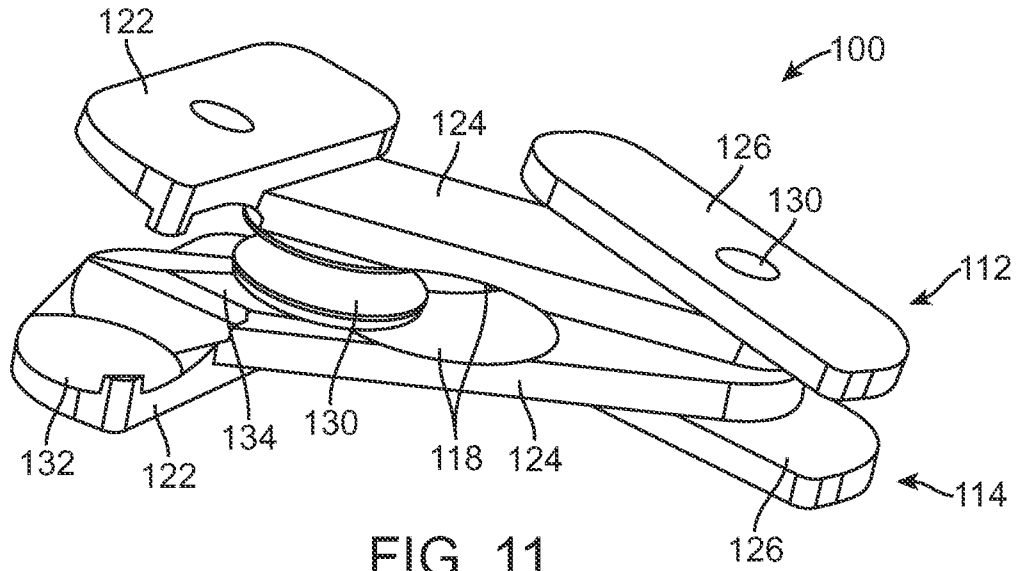

FIG. 10



INTERNATIONAL SEARCH REPORT

International application No

PCT/US2009/050575

A. CLASSIFICATION OF SUBJECT MATTER
INV. A61F2/44

According to International Patent Classification (IPC) or to both national classification and IPC

B. FIELDS SEARCHED

Minimum documentation searched (classification system followed by classification symbols)

A61F

Documentation searched other than minimum documentation to the extent that such documents are included in the fields searched

Electronic data base consulted during the international search (name of data base and, where practical, search terms used)

EPO-Internal

C. DOCUMENTS CONSIDERED TO BE RELEVANT

Category*	Citation of document, with indication, where appropriate, of the relevant passages	Relevant to claim No.
X	US 2007/299521 A1 (GLENN BRADLEY J [US] ET AL) 27 December 2007 (2007-12-27) claims 1,3,7,8,13,17-19; figures 16-24,44a-44f paragraphs [0095] - [0097], [0100], [0170] - [0174], [0180] - [0183]	1-17
A	WO 2007/121320 A (SPINALMOTION INC [US]; DE VILLIERS MALAN [ZA]; HOVDA DAVID [US]) 25 October 2007 (2007-10-25) figures 5-7b,14-17,27a-27c paragraphs [0084] - [0090], [0141], [0142]	1-3,5-7, 10-13
A	WO 2005/112834 A (MOSKOWITZ NATHAN C [US]) 1 December 2005 (2005-12-01) figures 6a-9a,13a-14b,20a-20f paragraphs [0071] - [0094], [0113] - [0115], [0127]	1-7,10, 13

 Further documents are listed in the continuation of Box C. See patent family annex.

* Special categories of cited documents:

A document defining the general state of the art which is not considered to be of particular relevance

E earlier document but published on or after the international filing date

L document which may throw doubts on priority claim(s) or which is cited to establish the publication date of another citation or other special reason (as specified)

O document referring to an oral disclosure, use, exhibition or other means

P document published prior to the international filing date but later than the priority date claimed

T later document published after the international filing date or priority date and not in conflict with the application but cited to understand the principle or theory underlying the invention

X document of particular relevance; the claimed invention cannot be considered novel or cannot be considered to involve an inventive step when the document is taken alone

Y document of particular relevance; the claimed invention cannot be considered to involve an inventive step when the document is combined with one or more other such documents, such combination being obvious to a person skilled in the art.

& document member of the same patent family

Date of the actual completion of the international search

23 October 2009

Date of mailing of the international search report

30/10/2009

Name and mailing address of the ISA/

European Patent Office, P.B. 5818 Patentlaan 2
NL - 2280 HV Rijswijk
Tel. (+31-70) 340-2040,
Fax: (+31-70) 340-3016

Authorized officer

Stach, Rainer

INTERNATIONAL SEARCH REPORT

International application No.
PCT/US2009/050575

Box No. II Observations where certain claims were found unsearchable (Continuation of item 2 of first sheet)

This international search report has not been established in respect of certain claims under Article 17(2)(a) for the following reasons:

1. Claims Nos.: 18-26
because they relate to subject matter not required to be searched by this Authority, namely:
Rule 39.1(iv) PCT - Method for treatment of the human or animal body by surgery
2. Claims Nos.:
because they relate to parts of the international application that do not comply with the prescribed requirements to such an extent that no meaningful international search can be carried out, specifically:
3. Claims Nos.:
because they are dependent claims and are not drafted in accordance with the second and third sentences of Rule 6.4(a).

Box No. III Observations where unity of invention is lacking (Continuation of item 3 of first sheet)

This International Searching Authority found multiple inventions in this international application, as follows:

1. As all required additional search fees were timely paid by the applicant, this international search report covers allsearchable claims.
2. As all searchable claims could be searched without effort justifying an additional fees, this Authority did not invite payment of additional fees.
3. As only some of the required additional search fees were timely paid by the applicant, this international search report covers only those claims for which fees were paid, specifically claims Nos.:
4. No required additional search fees were timely paid by the applicant. Consequently, this international search report is restricted to the invention first mentioned in the claims; it is covered by claims Nos.:

Remark on Protest

- The additional search fees were accompanied by the applicant's protest and, where applicable, the payment of a protest fee.
- The additional search fees were accompanied by the applicant's protest but the applicable protest fee was not paid within the time limit specified in the invitation.
- No protest accompanied the payment of additional search fees.

INTERNATIONAL SEARCH REPORT

Information on patent family members

International application No

PCT/US2009/050575

Patent document cited in search report	Publication date	Patent family member(s)	Publication date
US 2007299521 A1	27-12-2007	AU 2005309438 A1	01-06-2006
		BR PI0518488 A2	18-11-2008
		CA 2586594 A1	01-06-2006
		EP 1814498 A2	08-08-2007
		JP 2008520400 T	19-06-2008
		WO 2006058281 A2	01-06-2006
WO 2007121320 A	25-10-2007	AU 2007238092 A1	25-10-2007
		CA 2649107 A1	25-10-2007
		EP 2007322 A2	31-12-2008
		JP 2009533187 T	17-09-2009
		KR 20090007418 A	16-01-2009
		US 2008125864 A1	29-05-2008
		US 2007282449 A1	06-12-2007
WO 2005112834 A	01-12-2005	US 2005261769 A1	24-11-2005
		US 2005256576 A1	17-11-2005