



(19) **United States**

(12) **Patent Application Publication**

(10) **Pub. No.: US 2002/0016624 A1**

Patterson et al.

(43) **Pub. Date:**

Feb. 7, 2002

(54) **APPARATUS AND METHOD FOR CONTROLLED REMOVAL OF STENOTIC MATERIAL FROM STENTS**

(52) **U.S. Cl.** 623/1.12; 606/168

(75) Inventors: **Greg R. Patterson**, Pleasanton, CA (US); **Ronald G. Williams**, Menlo Park, CA (US); **James J. Leary**, Sunnyvale, CA (US)

(57) **ABSTRACT**

Apparatus and methods for treating in-stent restenosis are described for removing stenotic material from within previously stented regions of a patient's vasculature. The apparatus includes a catheter system having a stenotic material removal mechanism mounted on a distal portion of an elongated inner catheter. A sensing means, such as one or more sensing electrodes, are positioned on an outer surface of the apparatus. In addition, the apparatus optionally includes control means for diametrically expanding the stenotic material removal mechanism for effective recanalization of the stent. A coaxial outer catheter is provided for aspirating stenotic material which is removed from within the stent. In addition, embolic filter apparatus are described for collecting the stenotic material removed from within the stent. The methods comprise operating the stenotic material removal mechanism within a body vessel, typically a coronary artery or other artery, which has become restenosed or otherwise occluded following the initial stent placement, and sensing the proximity or contact between the stenotic material removal mechanism and the stent within the arterial wall so that the stenosis can be effectively recanalized without damaging the stent. The sensing means may be used to indicate an unsafe condition that might lead to stent damage, in response to which, the stenotic material removal mechanism may be manually or automatically deactivated. Alternatively or additionally, the sensing means may be used to indicate an appropriate endpoint for the stenotic material removal process.

Correspondence Address:

**TOWNSEND AND TOWNSEND AND CREW
TWO EMBARCADERO CENTER
EIGHTH FLOOR
SAN FRANCISCO, CA 94111-3834 (US)**

(73) Assignee: **Prolific Medical, Inc.**

(21) Appl. No.: **09/784,625**

(22) Filed: **Feb. 14, 2001**

Related U.S. Application Data

(60) Division of application No. 09/260,935, filed on Mar. 2, 1999, now Pat. No. 6,319,242, which is a division of application No. 08/857,659, filed on May 16, 1997, now Pat. No. 5,941,869, which is a continuation-in-part of application No. 08/798,722, filed on Feb. 12, 1997, now Pat. No. 5,882,329.

Publication Classification

(51) **Int. Cl.⁷** A61F 2/06; A61B 17/32

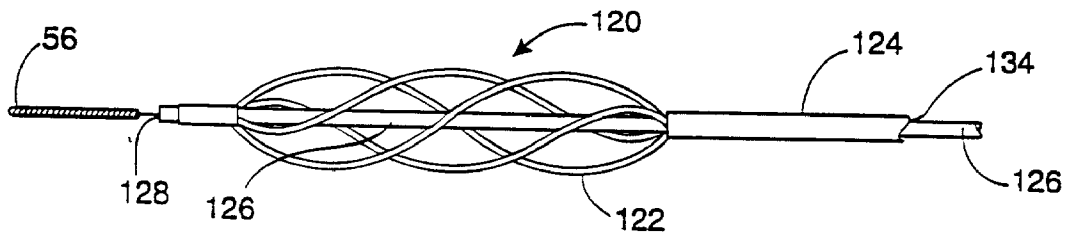

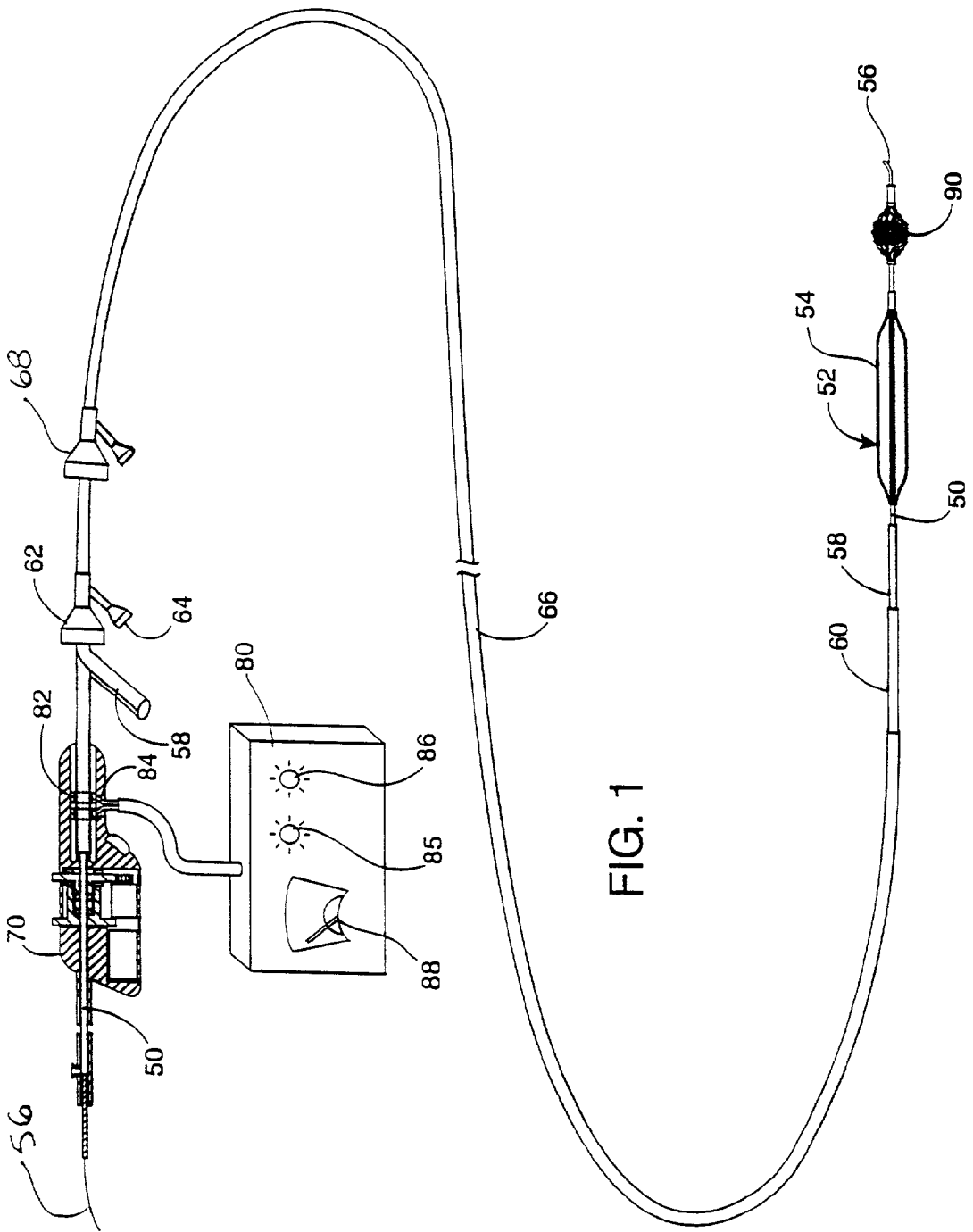

FIG. 1

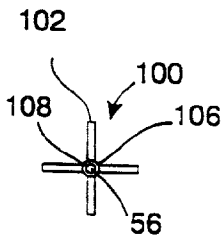
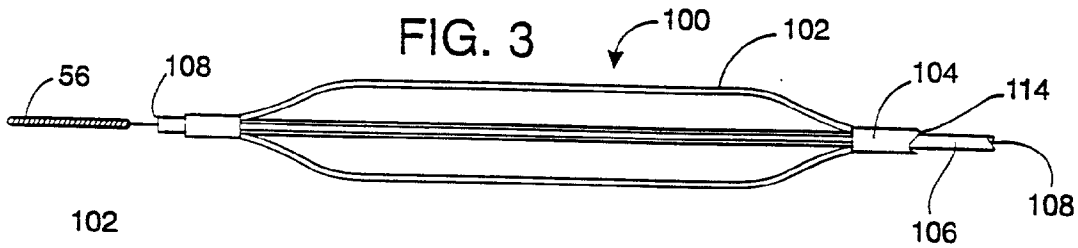
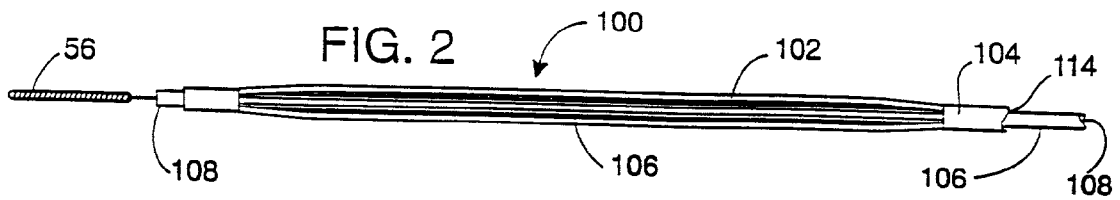

FIG. 4

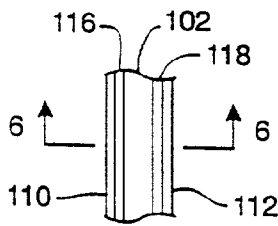

FIG. 5

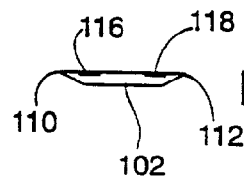

FIG. 6

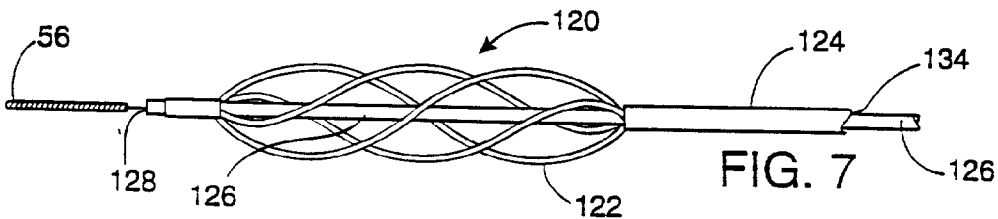

FIG. 7

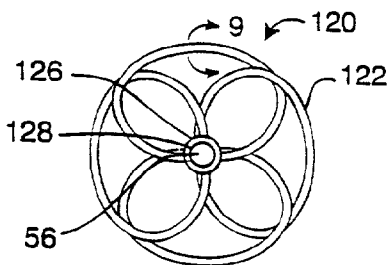

FIG. 8

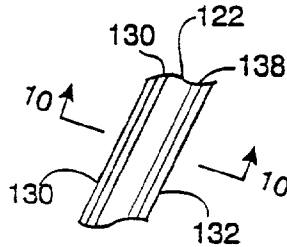

FIG. 9

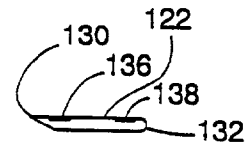

FIG. 10

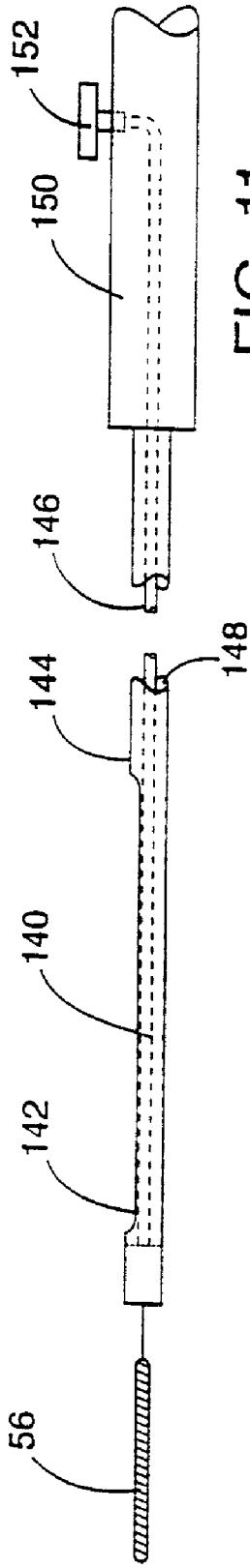

FIG. 11

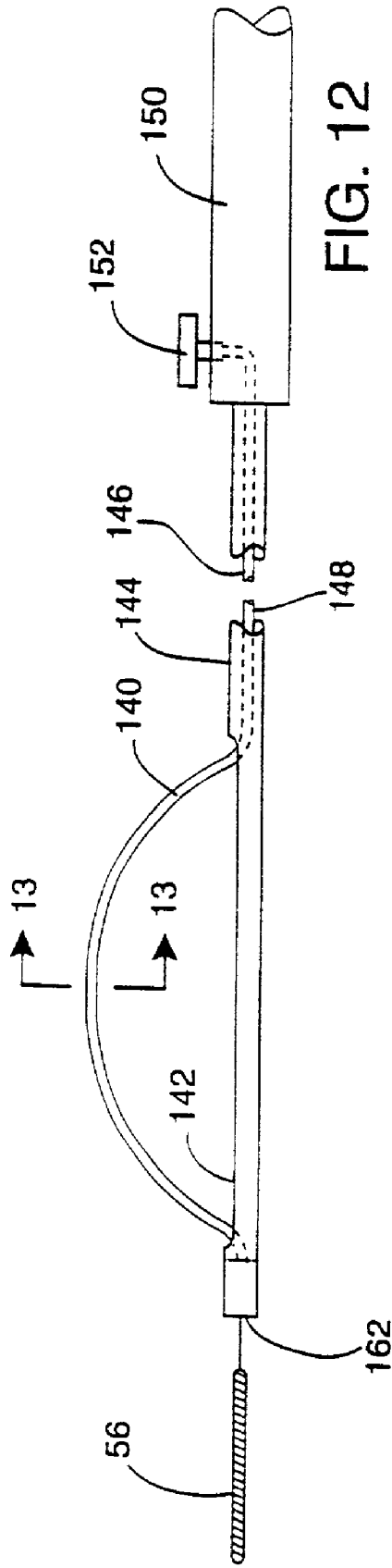

FIG. 12

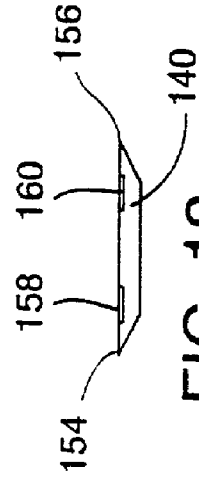
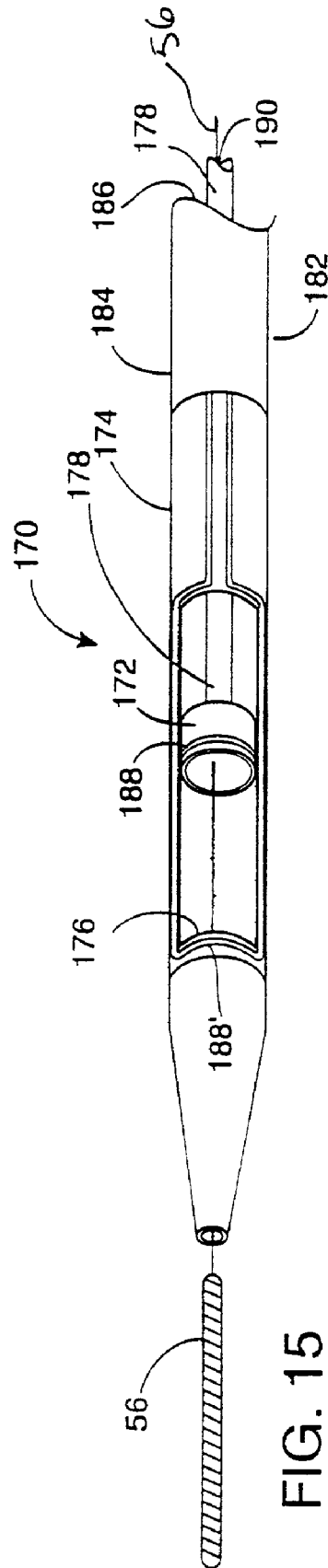
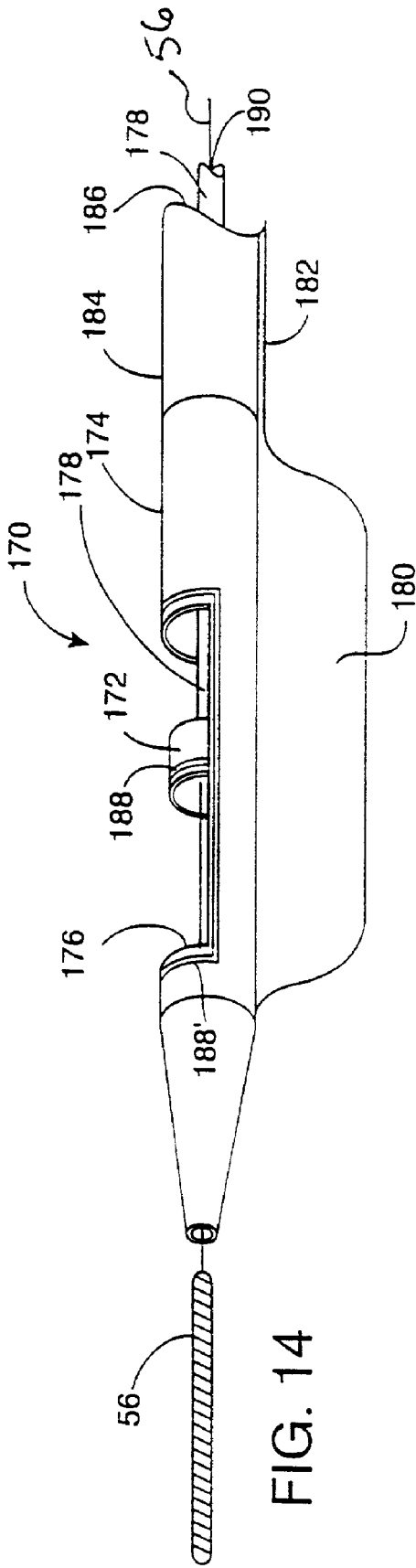

FIG. 13



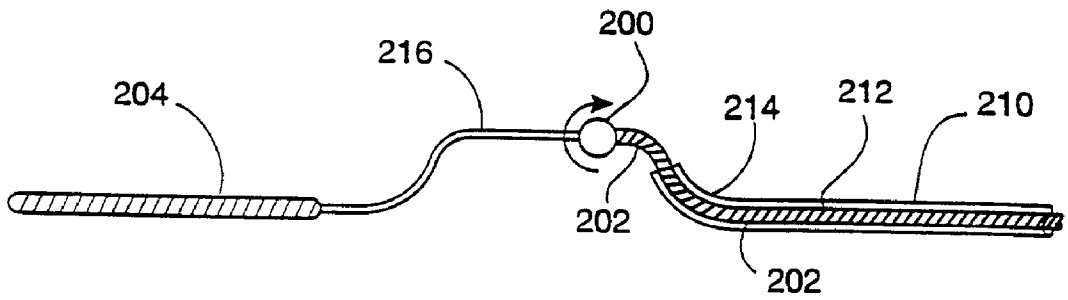

FIG. 16

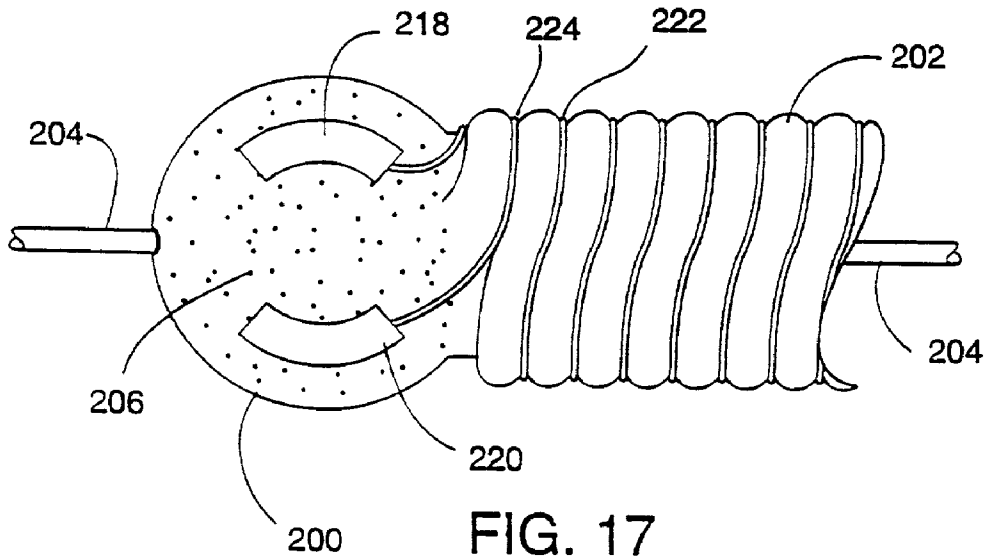
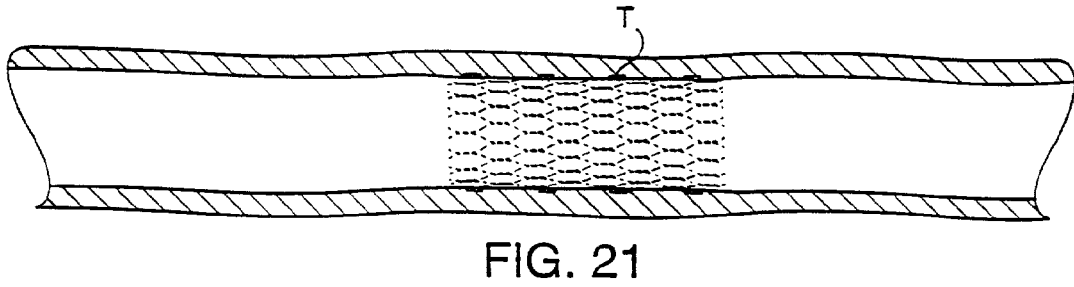
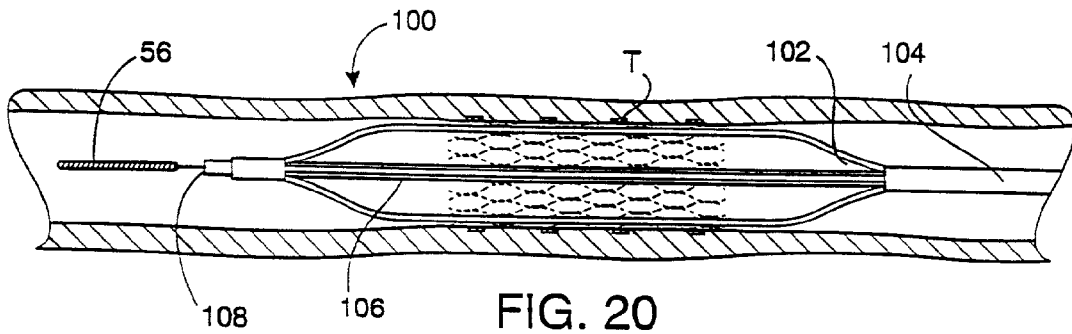
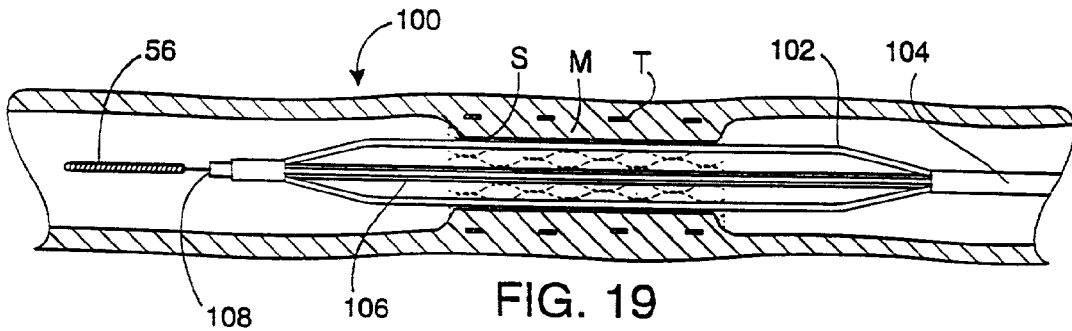
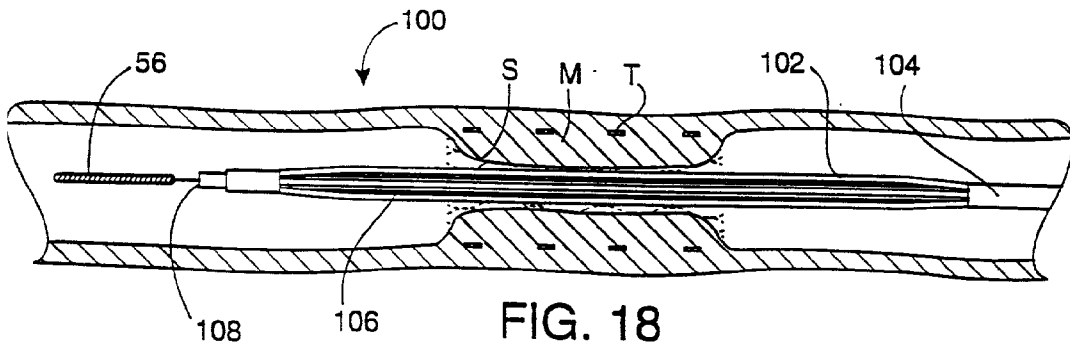

FIG. 17



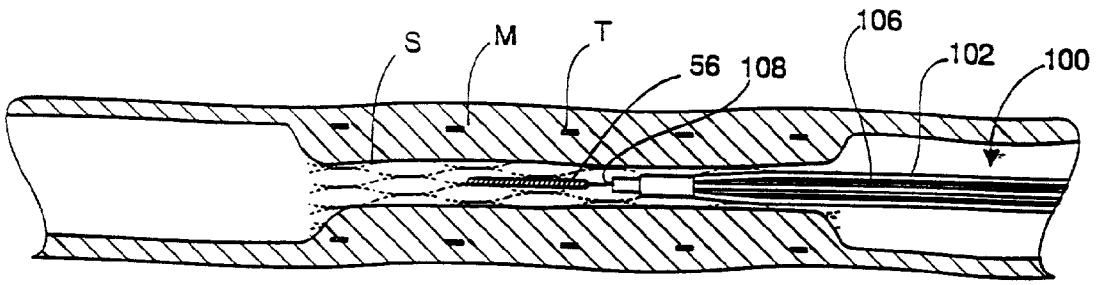

FIG. 22

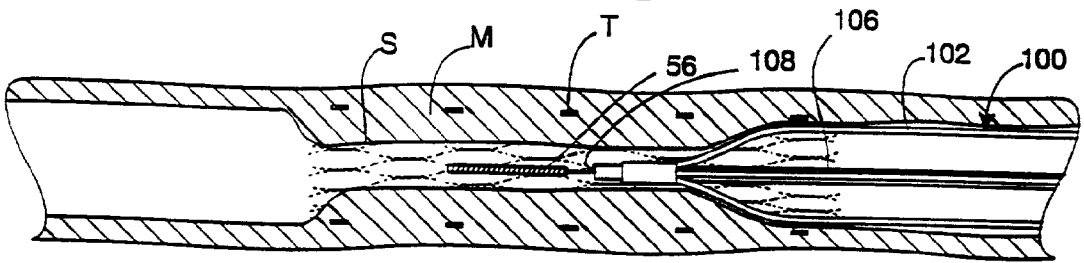

FIG. 23

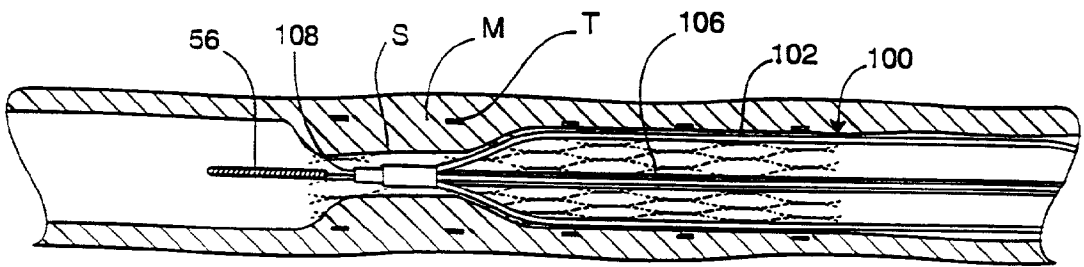

FIG. 24

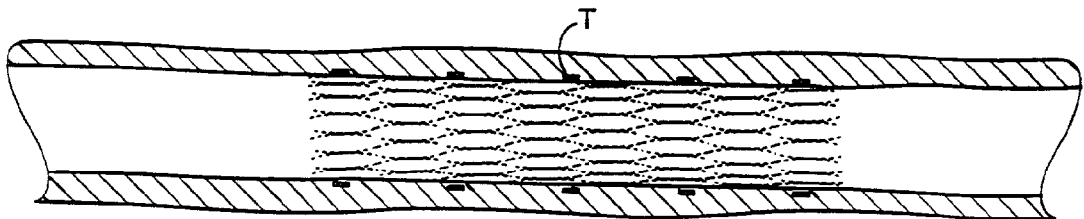

FIG. 25

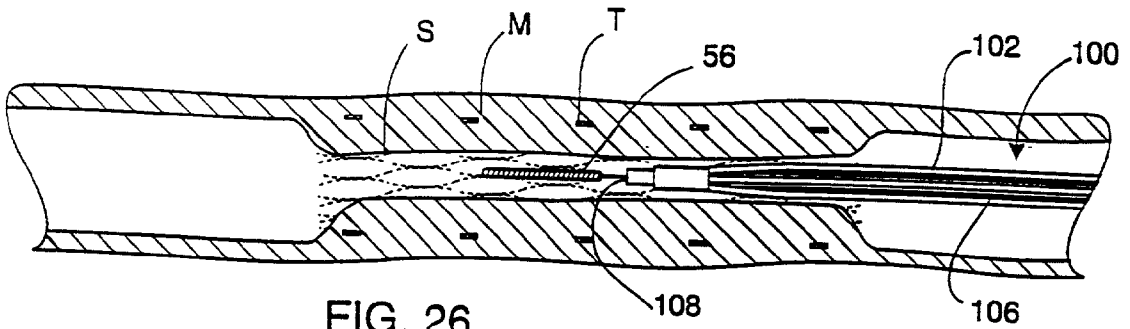

FIG. 26

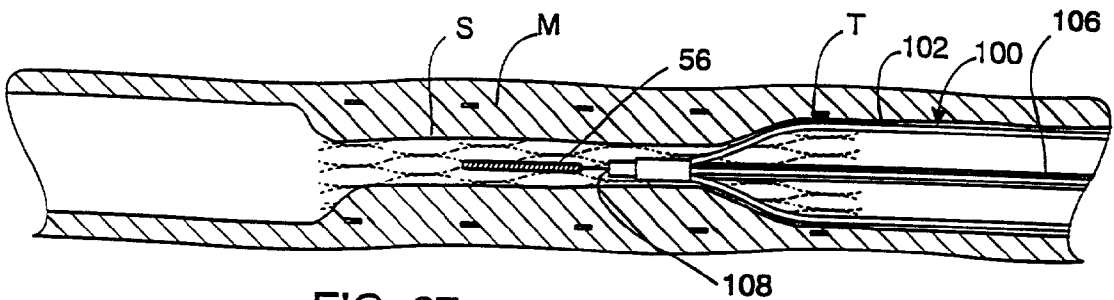

FIG. 27

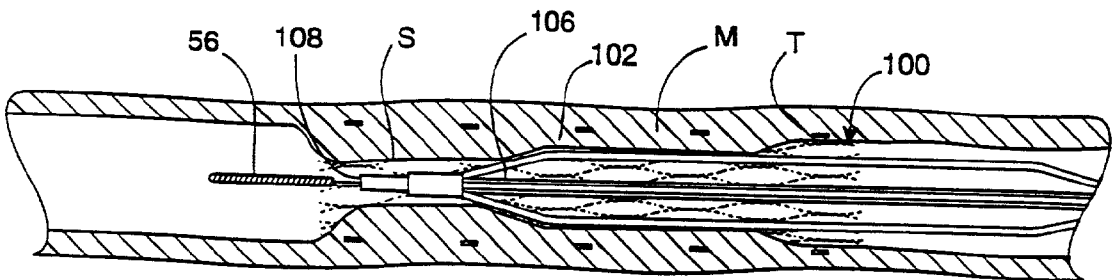

FIG. 28

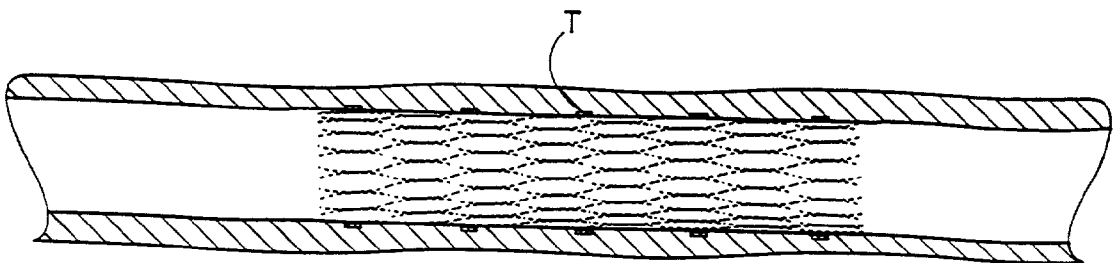
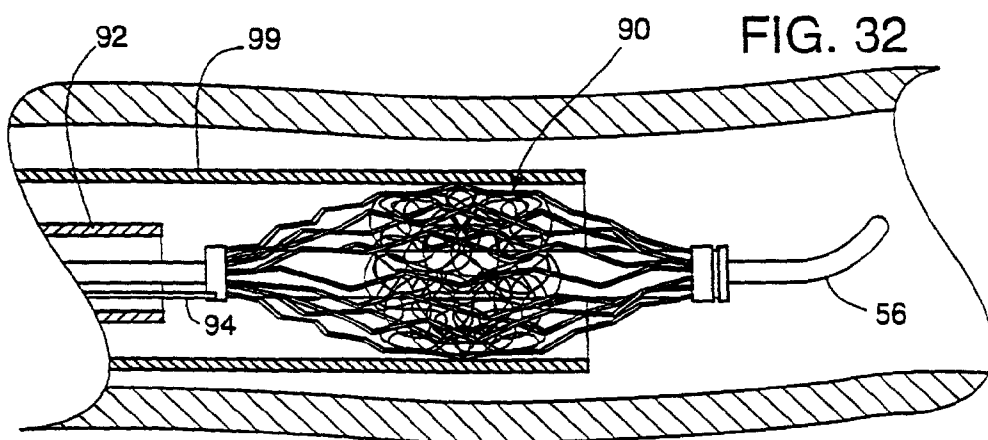
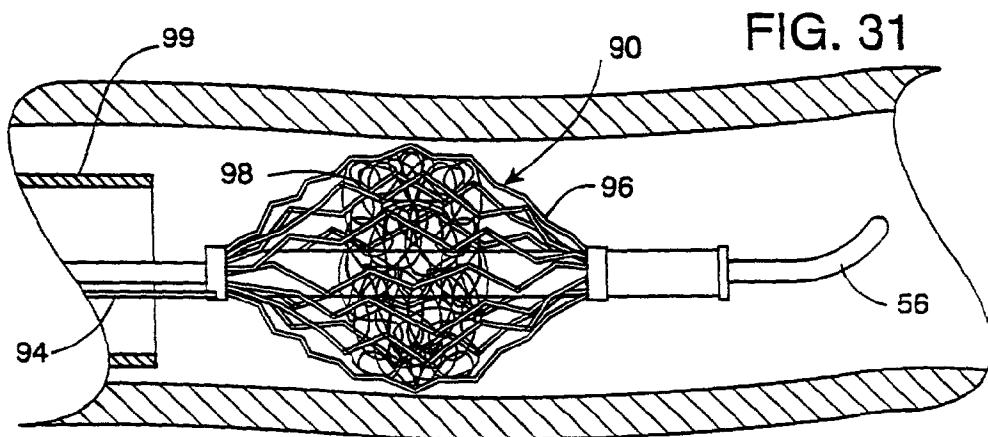
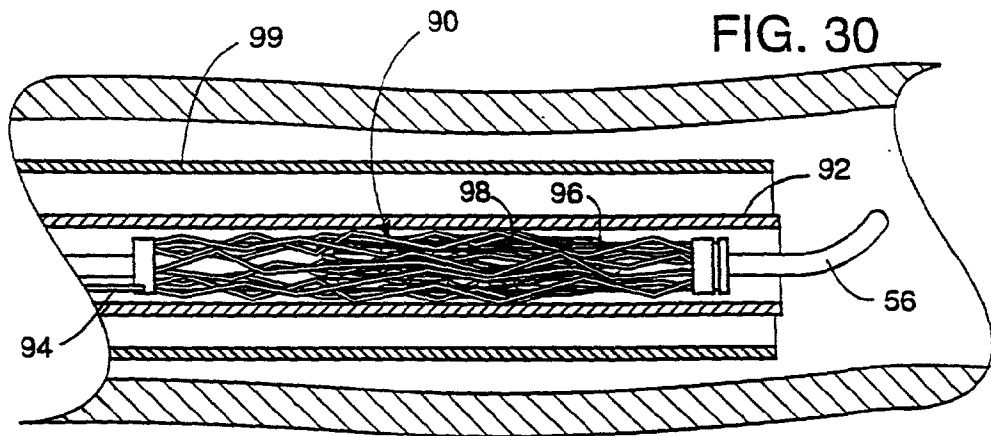

FIG. 29



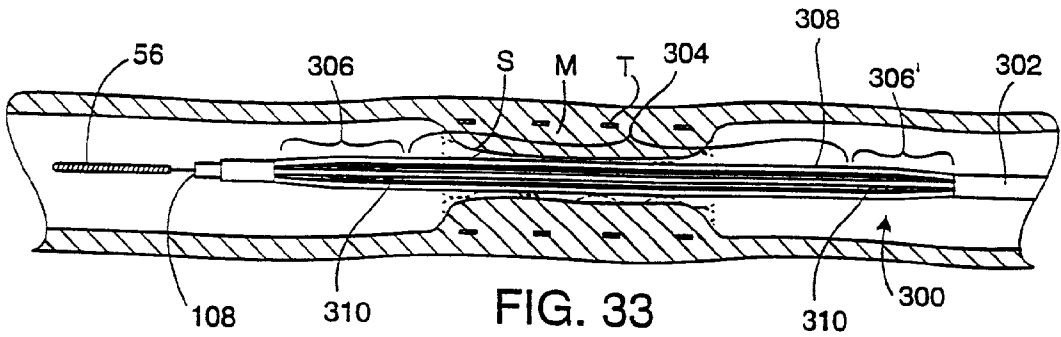

FIG. 33

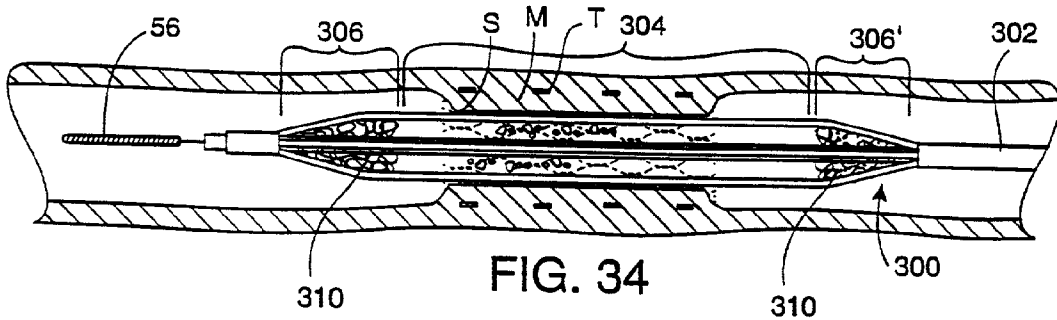

FIG. 34

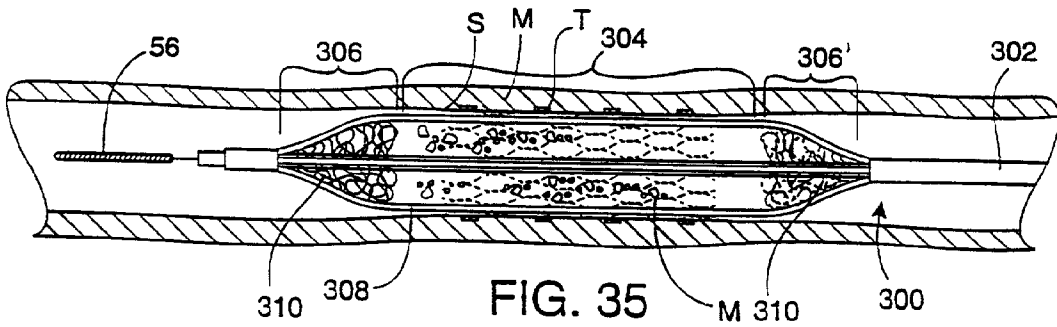

FIG. 35

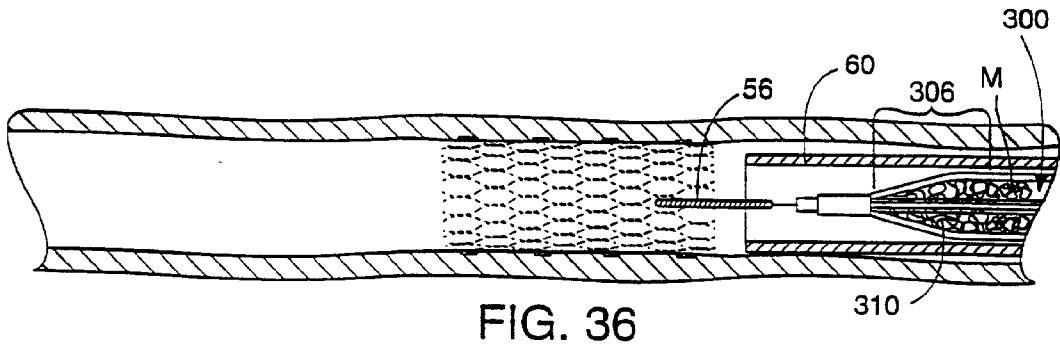

FIG. 36

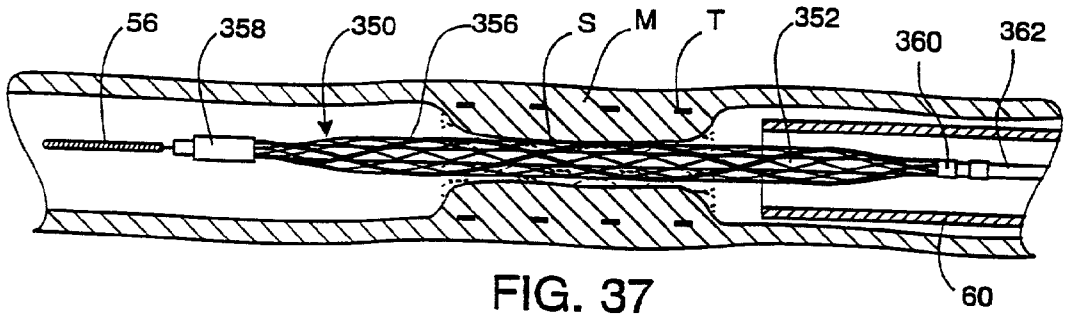

FIG. 37

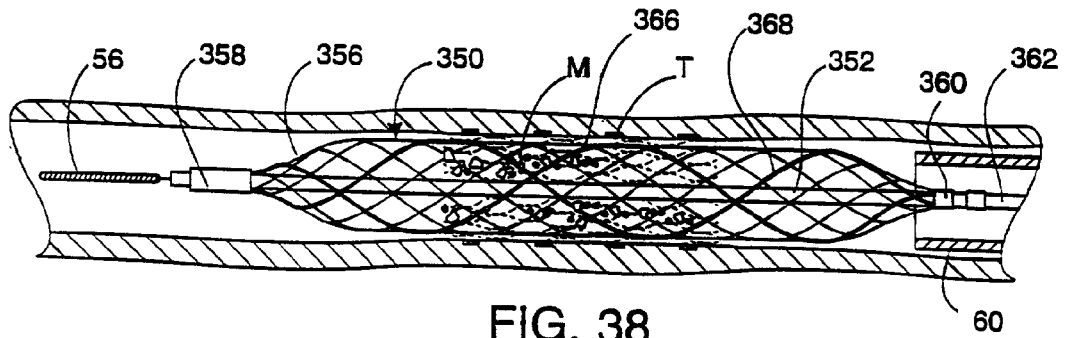

FIG. 38

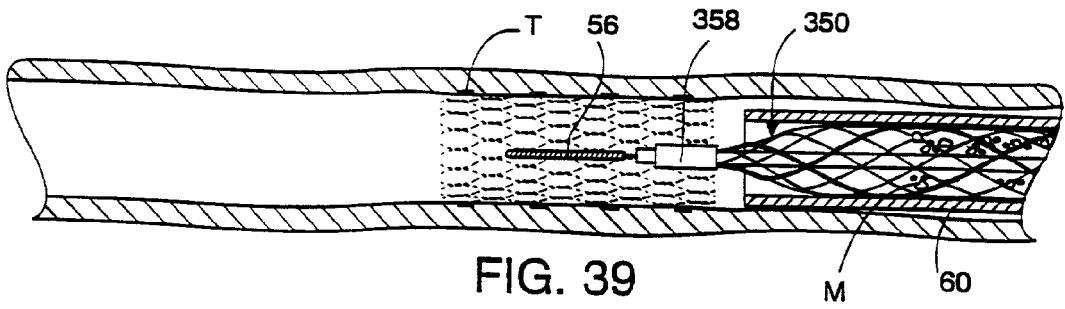

FIG. 39

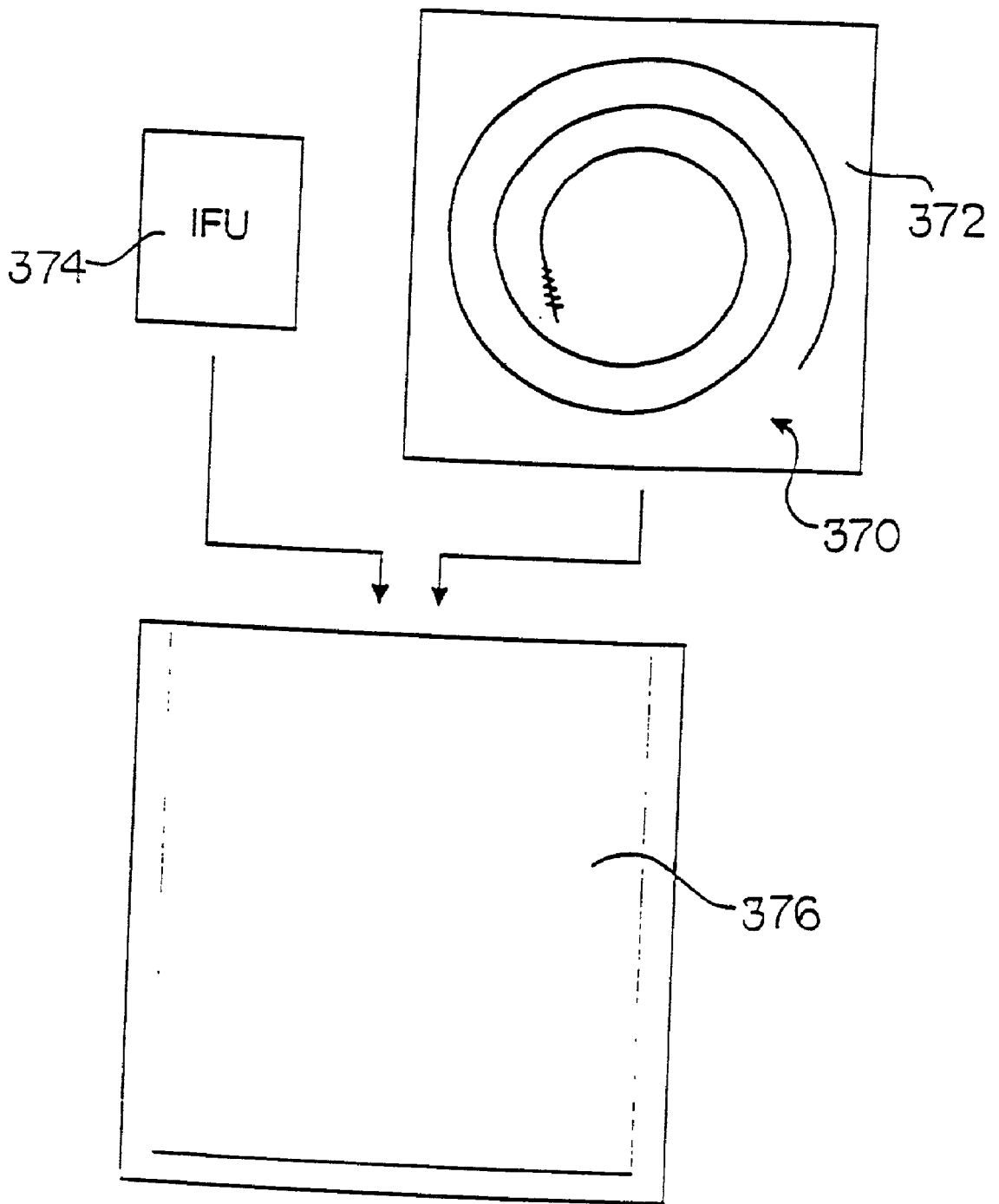

FIG 40

APPARATUS AND METHOD FOR CONTROLLED REMOVAL OF STENOTIC MATERIAL FROM STENTS

CROSS-REFERENCES TO RELATED APPLICATIONS

[0001] This patent application is a division of application Ser. No. 08/857,659, filed May 16, 1997, which is a continuation-in-part of co-owned, copending patent application, Ser. No. 08/798,722, filed Feb. 12, 1997, the entire disclosures of which are incorporated herein by reference.

BACKGROUND OF THE INVENTION

[0002] 1. Field of the Invention

[0003] The present invention relates generally to apparatus and methods for removing occluding material from stented regions within blood vessels which have restenosed. More particularly, the present invention relates to apparatus and methods for sensing a stent within the wall of a restenosed blood vessel and removing the occluding material without damaging the stent.

[0004] Percutaneous transluminal angioplasty (PTA) and percutaneous transluminal coronary angioplasty (PTCA) procedures are widely used for treating stenotic atherosclerotic regions of a patient's vasculature to restore adequate blood flow. Catheters having an expandible distal end, typically in the form of an inflatable balloon, are positioned in an artery, such as a coronary artery, at a stenotic site. The expandible end is then expanded to dilate the artery in order to restore adequate blood flow to regions beyond the stenosis. While PTA and PTCA have gained wide acceptance, these angioplasty procedures suffer from two major problems: abrupt closure and restenosis.

[0005] Abrupt closure refers to rapid reocclusion of the vessel within hours of the initial treatment, and often occurs in patients who have recently suffered acute myocardial infarction. Abrupt closure often results from either an intimal dissection or from rapid thrombus formation which occurs in response to injury of the vascular wall from the initial angioplasty procedure. Restenosis refers to a re-narrowing of the artery over the weeks or months following an initially apparently successful angioplasty procedure. Restenosis occurs in up to 50% of all angioplasty patients and results at least in part from smooth muscle cell proliferation and migration.

[0006] Many different strategies have been proposed to ameliorate abrupt closure and reduce the rate of restenosis. Of particular interest to the present invention, the implantation of vascular stents following angioplasty has become widespread. Stents are thin-walled tubular scaffolds which are expanded in the arterial lumen following the angioplasty procedure. Most commonly, the stents are formed from a malleable material, such as stainless steel, and are expanded in situ using a balloon. Alternatively, the stents may be formed from a shape memory alloy or other elastic material, in which case they are allowed to self-expand at the angioplasty treatment site. In either case, the stent acts as a mechanical support for the artery wall, inhibiting abrupt closure and reducing the restenosis rate as compared to PTCA.

[0007] While stents have been very successful in inhibiting abrupt closure and reasonably successful in inhibiting

restenosis, a significant portion of the treated patient population still experiences restenosis over time. Most stent structures comprise an open lattice, typically in a diamond or spiral pattern, and cell proliferation (also referred to as intimal hyperplasia) can intrude through the interstices between the support elements of the lattice. As a result, instead of forming a barrier to hyperplasia and restenosis, the stent can become embedded within an accumulated mass of thrombus and tissue growth, and the treatment site once again becomes occluded.

[0008] To date, proposed treatments for restenosis within previously stented regions of the coronary and other arteries have included both follow-up balloon angioplasty and directional atherectomy, e.g. using the Simpson directional atherectomy catheter available from Guidant Corporation, Santa Clara, Calif. Neither approach has been wholly successful. Balloon angioplasty can temporarily open the arterial lumen, but rarely provides long-term patency. Directional atherectomy can successfully debulk the lumen within the stent, but typically does not fully restore the stented lumen to its previous diameter because the catheter removes the stenotic material in an asymmetric pattern. Moreover, it has been found that the atherectomy cutting blades can damage the implanted stent. Such adverse effects were reported by Bowerman et al. in Disruption of a coronary stent during atherectomy for restenosis in the December 1991 issue of *Catheterization and Cardiovascular Diagnosis* and by Meyer et al. in *Stent wire cutting during coronary directional atherectomy* in the May 1993 issue of *Clinical Cardiology*. The possibility of such adverse outcomes is likely to limit the application of atherectomy as a treatment for stent restenosis and will probably result in more tentative use of the atherectomy cutter within the stented region when it is applied, leading to less complete removal of the stenosis.

[0009] For these reasons, it would be desirable to provide improved methods for treating restenosis within regions of the vasculature which have previously been implanted with stents. More particularly, it would be desirable to provide an apparatus for removal of stenotic material from within a stent which includes a sensing means for sensing when the stenosis removal mechanism is approaching or contacting the stent within the arterial wall so that the occluded artery can be effectively recanalized without damaging the stent. The stenosis removal mechanism of the apparatus may advantageously be a directional cutting or debulking device for selectively removing the stenotic material from within a stent or it may be a symmetrical cutting or debulking device for removing the stenotic material uniformly from the entire inner periphery of the stent.

[0010] 2. Description of the Background Art

[0011] Post-angioplasty restenosis is discussed in the following publications: Khanolkar (1996) *Indian Heart J.* 48:281-282; Ghannem et al. (1996) *Ann. Cardiol. Angeiol.* 45:287-290; Macander et al. (1994) *Cathet. Cardiovasc. Diagn.* 32:125-131; Strauss et al. (1992) *J. Am. Coll. Cardiol.* 20:1465-1473; Bowerman et al. (1991) *Cathet. Cardiovasc. Diagn.* 24:248-251; Moris et al. (1996) *Am. Heart J.* 131:834-836; Schomig et al. (1994) *J. Am. Coll. Cardiol.* 23:1053-1060; Haude et al., "Treatment of In-Stent Restenosis," in _____, Chapter 52, pages 357-365; Gordon et al. (1993) *J. Am. Coll. Cardiol.* 21:1166-1174; and Baim et

al. (1993) Am. J. Cardiol. 71:364366. These publications include descriptions of follow-up angioplasty and atherectomy as possible treatments for restenosis.

[0012] Atherectomy catheters having ultrasonic imaging transducers are described in U.S. Pat. Nos. 5,000,185 and 5,100,424. Rotary ablation catheters having selectively expandable burr components are described in U.S. Pat. Nos. 5,217,474 and 5,308,354. A catheter carrying an expandable filter is described in U.S. Pat. No. 4,723,549.

[0013] Thrombectomy and atherectomy catheters having rotating brush and filament structures are described in U.S. Pat. Nos. 5,578,018; 5,535,756; 5,427,115; 5,370,653; 5,009,659; and 4,850,957; WO 95/29626; DE 39 21 071 C2; and Netherlands 9400027.

[0014] Representative atherectomy catheters are described in U.S. Pat. Nos. 4,273,128; 4,445,509; 4,653,496; 4,696,667; 4,706,671; 4,728,319; 4,732,154; 4,762,130; 4,790,812; 4,819,634; 4,842,579; 4,857,045; 4,857,046; 4,867,156; 4,883,458; 4,886,061; 4,890,611; 4,894,051; 4,895,560; 4,926,858; 4,966,604; 4,979,939; 4,979,951; 5,011,488; 5,011,489; 5,011,490; 5,041,082; 5,047,040; 5,071,424; 5,078,723; 5,085,662; 5,087,265; 5,116,352; 5,135,483; 5,154,724; 5,158,564; 5,160,342; 5,176,693; 5,192,291; 5,195,954; 5,196,024; 5,209,749; 5,224,945; 5,234,451; 5,269,751; 5,314,438; 5,318,576; 5,320,634; 5,334,211; 5,356,418; 5,360,432; 5,376,100; 5,402,790; 5,443,443; 5,490,859; 5,527,326; 5,540,707; 5,556,405; 5,556,408; and 5,554,163.

[0015] The disclosures of these patent are incorporated herein by reference in their entirety.

SUMMARY OF THE INVENTION

[0016] The present invention provides apparatus and methods for removing stenotic material from within previously stented regions of a patient's vasculature. The present invention is particularly intended for treating regions of restenosis within a stent which result from accumulation of cellular, thrombotic, and other material over the weeks and months following an initially successful stent implant. The present invention will also be useful for treating relatively rapid thrombus formation which may sometimes occur during the hours and days following a stent placement procedure.

[0017] Methods according to the present invention comprise operating a stenotic material removal mechanism within a blood vessel, typically a coronary artery or other artery, which has become restenosed or otherwise occluded following the initial stent placement, and sensing the proximity or contact between the stenotic material removal mechanism and the stent within the arterial wall so that the occluded vessel can be effectively recanalized without damaging the stent. The sensing means for sensing the proximity or contact between the stenotic material removal mechanism and the stent may be used to indicate an unsafe condition that might lead to stent damage, in response to which, the stenotic material removal mechanism may be manually or automatically deactivated. Alternatively or additionally, the sensing means may be used to indicate an appropriate endpoint for the stenotic material removal process.

[0018] According to this second aspect, the indication of the proximity or contact between the stenotic material

removal mechanism and the stent provided by the sensing means may be used as feedback for controlling the stenotic material removal process in the following ways: When used in conjunction with a directional stenotic material removal mechanism, the sensing means may be used to guide the directional stenotic material removal mechanism either to remove stenotic material from selected portions of the interior of the stent or to remove stenotic material uniformly from the entire inner periphery of the stent. When used in conjunction with a controllable-depth stenotic material removal mechanism, the indication from the sensing means may be used as feedback to manually or automatically control the depth of stenotic material removal, preferably to remove stenotic material uniformly from the entire inner periphery of the stent. When used in conjunction with a controllable-width or diameter stenotic material removal mechanism, the indication from the sensing means may be used as feedback to manually or automatically control the width or diameter of the blood flow channel created within the stent. In certain embodiments of the method, the feedback from the sensing means may be used to control a combination of the directionality and the depth or diameter of the stenotic material removal process either to remove stenotic material from selected portions of the interior of the stent or to remove stenotic material uniformly from the entire inner periphery of the stent.

[0019] In a preferred aspect of the method of the present invention, a catheter carrying the stenotic material removal mechanism is positioned on one side of the restenosed stented region. The stenotic material removal mechanism is advanced from the catheter and positioned across the stenosis within the stent. The stenotic material removal mechanism is then expanded within the stenosis. The expansion may occur passively, as with a resilient stenotic material removal mechanism having one or more resilient members, such as one or more wire-shaped cutting blades, which are released from a tubular sheath and allowed to expand. Otherwise, the expansion may occur actively and controllably, such as with a stenotic material removal mechanism having one or more wire-shaped cutting blades which are actively and controllably extended outward to increase the width or diameter of the stenotic material removal mechanism, or such as a stenotic material removal mechanism having a cutter within a housing and an inflatable balloon located on one side of the housing which is inflated to increase the width or diameter of the stenotic material removal mechanism. The stenotic material removal mechanism is then activated for removing the stenotic material from within the stent. This is typically done by rotating and/or translating the entire stenotic material removal mechanism or a component of it within the stenosis. Medications, chemicals, ionizing radiation or energy, such as electrical, magnetic, ultrasonic, hydraulic, pulsed hydraulic, laser or thermal energy may be applied to assist in removal of the stenotic material and/or for denaturing the remaining tissue to discourage further restenosis at the treatment site. A sensing means which is located on or adjacent to the stenotic material removal mechanism monitors the proximity or contact between the stenotic material removal mechanism and the stent. When the stenotic material removal mechanism has approached close enough to the stent to indicate effective recanalization of the stenosis, the stenotic material removal mechanism is deactivated. In this way, the sensing means provides an interaction between the stenotic

material removal mechanism and the stented vessel to achieve effective recanalization of the stenosis without damaging or dislodging the stent within the vessel wall.

[0020] In an alternative aspect of the method of the present invention, the catheter carrying the stenotic material removal mechanism is positioned on one side of the restenosed stented region. The stenotic material removal mechanism is extended from the catheter and advanced part-way into the stenosis within the stent. The stenotic material removal mechanism is then expanded within the stenosis, either passively or actively and controllably as described above, to increase the width or diameter of the stenotic material removal mechanism. The stenotic material removal mechanism is then activated for removing the stenotic material from within a portion of the stent. This may be done by rotating and/or translating the entire stenotic material removal mechanism or a component of it within the stenosis. Medications, chemicals, ionizing radiation or energy, such as electrical, magnetic, ultrasonic, hydraulic, pulsed hydraulic, laser or thermal energy may be applied to assist in removal of the stenotic material and/or for denaturing the remaining tissue to discourage further restenosis at the treatment site. A sensing means which is located on or adjacent to the stenotic material removal mechanism monitors the proximity or contact between the stenotic material removal mechanism and the stent. When the stenotic material removal mechanism has approached close enough to the stent to indicate effective recanalization of that portion of the stenosis, the stenotic material removal mechanism is advanced farther into the stenosis. The stenotic material removal mechanism may be deactivated and advanced step-wise into the stenosis by contracting or compressing the stenotic material removal mechanism, advancing it a short distance and expanding it again in a new portion of the stent. Otherwise, the stenotic material removal mechanism may be advanced continuously, relying on either the resiliency of the stenotic material removal mechanism or active control for adjusting the width or diameter of the stenotic material removal mechanism as it advances. When the sensing means indicates that the new portion of the stent has been effectively recanalized, the stenotic material removal mechanism is advanced again along the stenosis until the entire stented region has been recanalized.

[0021] Alternatively, the stenotic material removal mechanism may be extended from the catheter and advanced all the way across the stenosis in a contracted or compressed state. The stenotic material removal mechanism is then expanded within the far end of the stenosis or within the vessel beyond the stenosis, either passively or actively and controllably as described above, to increase the width or diameter of the stenotic material removal mechanism. The stenotic material removal mechanism is then activated for removing the stenotic material while withdrawing the stenotic material removal mechanism toward the catheter to advance it through the stenosis in either a step-wise or continuous fashion. Medications, chemicals, ionizing radiation or energy, such as electrical, magnetic, ultrasonic, hydraulic, pulsed hydraulic, laser or thermal energy may be applied to assist in removal of the stenotic material and/or for denaturing the remaining tissue to discourage further restenosis at the treatment site. The sensing means which is used to monitor the proximity or contact between the stenotic material removal mechanism and the stent in order to control the

diameter and/or the rate of advancement of the stenotic material removal mechanism for effective recanalization of the stenosis within the stent.

[0022] The methods of the present invention may include providing a sensing means in the form of one or more open, exposed electrodes which are located on or adjacent to the stenotic material removal mechanism. A direct or alternating current reference voltage is applied to a unipolar electrode or applied between two bipolar electrodes, and the current leakage of the electrode or electrodes is monitored. When one or more of the electrodes contacts the metallic stent, the leakage current increases indicating that the stenotic material has been removed down to the stent support members for effective recanalization of the stenosis within that portion of the stent. Alternatively, the methods of the present invention may include providing a sensing means in the form of two exposed or insulated bipolar electrodes which are located on or adjacent to the stenotic material removal mechanism. An alternating current reference voltage is applied between the bipolar electrodes, and the complex impedance between the electrodes is monitored. As the electrodes approach the metallic stent, the capacitive and inductive characteristics of the electrode circuit change, which can be detected as a change in the complex impedance between the electrodes. When the complex impedance between the electrodes has changed a sufficient amount to indicate effective recanalization of the stenosis within that portion of the stent, the stenotic material removal mechanism may be deactivated or advanced along the stenosis as appropriate. The sensing means can be used to control or guide the stenotic material removal mechanism to remove the stenotic material to within a predetermined thickness of the stent support members or the stenotic material can be removed all the way down to the stent support members without fear of damaging the stent. If exposed electrodes are used in this method, monitoring the complex impedance between the electrodes will indicate when the stenotic material removal mechanism is approaching the metallic stent, then when one or more of the electrodes contacts the metallic stent, it will ground to the stent which can be detected as an extreme change in the complex impedance or as a rise in the leakage current. Thus, the sensing means can be used to separately indicate proximity and contact between the stenotic material removal mechanism and the stent. The sensing means can operate with very low voltage and current that will not create any adverse physiological effects on the vascular wall or the tissues and nerve pathways of the heart.

[0023] In embodiments where the stenotic material removal mechanism uses direct or alternating current electrical energy to assist in removal of the stenotic material and/or for denaturing the remaining tissue to discourage further restenosis at the treatment site, for example by heating or by radio frequency ablation, the heating or ablation electrodes can serve double duty as the sensing means electrodes for monitoring proximity or contact with the metallic stent.

[0024] Other types of proximity sensors sensitive to the metallic stent may be used in place of those described. Alternatively, optical or ultrasonic sensors may be used in place of the electronic detectors described for detection of both metallic and nonmetallic stents. For example, a non-imaging, A mode ultrasonic transducer can be used to detect both metallic and nonmetallic stents and to measure their

depth within the arterial wall based on echoes caused by the difference in acoustic impedance between the stent material and the arterial tissue or stenosis.

[0025] The methods of the present invention will optionally further comprise collecting and withdrawing the removed stenotic material from the blood vessel. Collection and withdrawal of the removed stenotic material may be accomplished using the same catheter or catheter assembly which carries the stenotic material removal mechanism, typically by aspiration, entrapment, filtering or some combination thereof. It will be appreciated that various catheter assemblies can be put together using coaxially arranged components which may be introduced through a single vascular access point, such as a femoral or brachial artery. Alternatively, collection and withdrawal can be accomplished using separate collection apparatus, such as a catheter or catheter assembly, which is introduced through a separate access point. In some instances, it may be desirable to partially or totally isolate the stented region from circulation during recanalization. For example, embolic filters or occlusion balloons may be placed upstream and downstream of the treatment site. Alternatively or additionally, the methods of the present invention may optionally further comprise comminution of the removed stenotic material into microscopic particles that will not cause embolization downstream of the treatment site.

[0026] The methods of the present invention will also optionally comprise the use of introducer means, such as introducer needles, guidewires and/or introducer sheaths for introducing the catheter or catheter system into the vascular system and guide means, such as steerable guidewires and selective and/or subselective guiding or delivery catheters for guiding and advancing the catheter or catheter system through the vasculature to the treatment site and supporting it during the treatment. The selective and subselective guiding or delivery catheters may also serve the functions of aspiration, collection and withdrawal of the removed stenotic material, as well as for infusion of therapeutic substances.

[0027] Apparatus according to the present invention include catheters, catheter systems, and catheter kits which are specially intended and adapted for performing the methods described above. In particular, the apparatus are designed to afford percutaneous intravascular placement of a catheter carrying a stenotic material removal mechanism for removing stenotic material from within a previously stented region of the vasculature and a sensing means for sensing when the stenotic material removal mechanism is approaching or contacting the stent within the vascular wall. This inventive combination facilitates the effective recanalization of previously placed vascular stents that have become restenosed without risking damaging the stent. To that end, catheter systems according to the present invention may comprise an inner catheter shaft having a proximal end and a distal end. The stenotic material removal mechanism is disposed near the distal end of the inner catheter shaft. The inner catheter shaft will preferably include a guidewire lumen for introduction of the catheter system over a steerable guidewire. The inner catheter shaft may have additional lumens or actuating mechanisms associated with the stenotic material removal mechanism. Various embodiments of the stenotic material removal mechanism will be more fully described below. In embodiments where the stenotic mate-

rial removal mechanism comprises resilient members which are radially compressible, the catheter system may also include a tubular sheath which serves to maintain the stenotic material removal mechanism in a compressed state as it is maneuvered to, and potentially across, the stenosis. The catheter system will usually further include an outer catheter tube having a proximal end, a distal end and an inner lumen. The outer catheter tube will usually have an aspiration port near its proximal end so that dislodged stenotic material can be aspirated from the vasculature. The outer catheter tube may optionally have selective or subselective curves formed near the distal end of the catheter tube for directing and maneuvering the catheter system through the vasculature to the site of the stenosis. In addition, an outer guiding catheter, for example a coronary guiding catheter, may be used for guiding the catheter system into the desired part of the vasculature and supporting it during the treatment.

[0028] The stenotic material removal mechanism which is disposed near the distal end of the inner catheter shaft may take one of several possible forms. In a first illustrative embodiment of the apparatus, the stenotic material removal mechanism is in the form of a cutting head having a plurality of longitudinally oriented cutting blades arranged radially about the central axis of the inner catheter. In a second illustrative embodiment of the apparatus, the stenotic material removal mechanism is in the form of a cutting head having a plurality of helically configured cutting blades arranged radially about the central axis of the inner catheter. In these first and second illustrative embodiments, each of the cutting blades is preferably shaped like a flattened wire with one or both lateral edges of the wire sharpened into a cutting edge. The wire-shaped cutting blades are resilient so that they can expand radially outward from the central axis of the inner catheter. Preferably, the wire-shaped cutting blades maintain an approximately parallel orientation to one another as they expand and contract in the radial direction so that the overall configuration of the cutting head is roughly cylindrical. The cutting head can be passively expandable, in which case the resilient wire-shaped cutting blades are treated by coldworking or heat treatment to have an elastic memory that predisposes them to expand outward when they are released from the radial constraint of the tubular sheath. Alternatively, the cutting head can be configured to be actively and controllably expandable. In this case, the resilient wire-shaped cutting blades are attached on their proximal ends to the inner catheter shaft and on their distal ends to an inner actuating member which is coaxially slidably with respect to the inner catheter shaft. When the inner actuating member is moved proximally with respect to the inner catheter shaft, the resilient wire-shaped cutting blades expand radially outward from the central axis of the inner catheter, and when the inner actuating member is moved distally with respect to the inner catheter shaft, the resilient wire-shaped cutting blades contract radially inward toward the central axis of the inner catheter. The resilient wire-shaped cutting blades may be treated by coldworking or heat treatment to have an elastic memory so that they are biased toward the contracted position, the expanded position or an intermediate position, each alternative having various advantages. The inner actuating member may be tubular, such as a polymer tube, a hollow flexible cable or a flexible metallic tube, so that the guidewire lumen can pass coaxially through the inner actuating member. Alternatively, the inner

actuating member may be a thin wire which runs parallel to and alongside the guidewire lumen.

[0029] The stenotic material removal mechanism is operated by rotating the cutting head to remove the stenotic material from within the stent by the cutting action of the longitudinally oriented cutting blades. The rotating action of the blades may be accompanied by axially advancing or withdrawing the cutting head through the stenosis and/or by expanding the width or diameter of the cutting head. In accordance with the methods described above, one or more of the longitudinally oriented cutting blades includes a sensing means for sensing the proximity or contact between the cutting blades and the stent. The sensing means may be in the form of one or more electrode wires which are positioned on the cutting blades. When the sensing means detects sufficient proximity or contact between the cutting blades and the stent to indicate effective recanalization of the stenosis, the cutting head is deactivated and withdrawn from the stented vessel.

[0030] Additionally or alternatively, energy, such as electrical, ultrasonic or thermal energy may be applied through the cutting blades to assist in removal of the stenotic material and/or for denaturing the remaining tissue to discourage further restenosis at the treatment site. In this case, electrodes used for heating or ablation can serve double duty as the sensing means electrodes for monitoring proximity or contact with the stent.

[0031] In a third illustrative embodiment of the apparatus, the stenotic material removal mechanism is in the form of a blade which is extendible and retractable from within a cavity or lumen located near the distal end of the inner catheter. The blade is actuated to extend radially from the inner catheter by advancing an actuating member which extends through an inner lumen of the catheter to an advancement knob located near the proximal end of the inner catheter. Preferably, the blade maintains an approximately parallel orientation to the inner catheter as it extends and retracts in the radial direction. The stenotic material removal mechanism may operate by cutting action, in which case the blade is preferably shaped like a flattened wire with one or both lateral edges of the wire sharpened into a cutting edge, or it may operate by application of electrical or thermal energy, in which case the blade may be flat, round or any convenient shape.

[0032] The stenotic material removal mechanism is operated by advancing the actuating member to extend the blade radially from the inner catheter, then rotating the catheter about its longitudinal axis to remove the stenotic material from within the stent. The rotating action of the blades may be accompanied by axially advancing or withdrawing the inner catheter through the stenosis. A sensing means for sensing the proximity or contact between the blade and the stent is positioned on the blade of the catheter. The sensing means may be in the form of one or more electrode wires which are positioned on the cutting blade. If the stenotic material removal mechanism operates by electrical or thermal heating or ablation, the heating or ablation electrodes can also serve as the sensing means electrodes for monitoring proximity or contact with the stent. When the sensing means detects sufficient proximity or contact between the blade and the stent to indicate effective recanalization of the stenosis, the cutting blade is deactivated and withdrawn from the stented vessel.

[0033] In a fourth illustrative embodiment of the apparatus, the stenotic material removal mechanism has a cutter positioned within a housing. The housing has a side aperture which exposes the cutter and an inflatable balloon located on the back of the housing opposite the side aperture. The balloon can be inflated to increase the width or diameter of the stenotic material removal mechanism and thereby to control the depth of cut and the diameter of the blood flow channel created. The cutter may be a cup-shaped rotating blade, a rotating linear or helical blade, a rotating abrasive burr or a reciprocating or axially movable cutting blade. Additionally or alternatively, medications, chemicals, ionizing radiation or energy, such as electrical, magnetic, ultrasonic, hydraulic, pulsed hydraulic, laser or thermal energy may be applied through the cutter to assist in removal of the stenotic material and/or for denaturing the remaining tissue to discourage further restenosis at the treatment site.

[0034] The stenotic material removal mechanism is positioned by advancing the inner catheter so that the side aperture of the housing is situated across the stenosis within the stent and inflating the balloon to press the side aperture against the stenotic material. Then, the cutter is actuated by rotating and/or by axially advancing the cutter within the housing to remove stenotic material from within the stent. A sensing means for sensing the proximity or contact between the stenotic material removal mechanism and the stent is positioned on the cutter and/or the housing of the catheter. Again, the sensing means may be in the form of one or more electrode wires which are positioned on the cutter and/or the housing. If the stenotic material removal mechanism operates by electrical or thermal heating or ablation, the heating or ablation electrodes can also serve as the sensing means electrodes for monitoring proximity or contact with the stent. When the sensing means detects sufficient proximity or contact between the cutter and the stent to indicate the desired depth of cut, the cutter is deactivated and withdrawn or directed to another part of the stenosis within the stented portion of the vessel.

[0035] In a fifth illustrative embodiment of the apparatus, the stenotic material removal mechanism has a rotating cutting head attached to a hollow drive cable which is coaxially and rotatably positioned over a guidewire. The rotating cutting head is typically spherical or ovoid in shape and has cutting blades, teeth or abrasive particles on its exterior surface. Optionally, the inner catheter or guidewire may have a bend or a steering mechanism close to its distal end for directing the cutting head against the stenotic material within the stent. Alternatively or additionally, the cutting head may also have control means for adjusting the outer diameter of the cutting head. A sensing means for sensing the proximity or contact between the cutting head and the stent is positioned on the cutting head. The sensing means may be in the form of one or more electrodes which are positioned on the cutting head.

[0036] The stenotic material removal mechanism is operated by advancing the inner catheter so that the cutting head is positioned within the stenosis, then rotating the drive cable and the cutting head to remove stenotic material from within the stent. The rotating action of the cutting head may be accompanied by axially advancing or withdrawing the cutting head through the stenosis. The cutting blades, teeth or abrasive particles on the exterior surface of the cutting head comminute or pulverize the stenotic material into fine

particles that will not cause embolization downstream of the treatment site. The optional bend or steering mechanism of the inner catheter or guidewire may be used for directing the cutting head against the stenotic material within the stent. Alternatively, the control means may be used for adjusting the diameter of the cutting head to achieve effective recanalization of the stented artery. When the sensing means indicates sufficient proximity or contact between the cutting head and the stent, the cutting head is deactivated and withdrawn or directed to another part of the stenosis within the stented portion of the vessel.

[0037] Each embodiment of the apparatus of the present invention will also include a monitoring means which couples to the sensor means of the catheter system through a connection fitting at the proximal end of the inner catheter. In one preferred embodiment, the monitoring means includes a voltage source that generates a direct or alternating current reference voltage which is applied to a unipolar electrode or applied between two bipolar electrodes positioned on the stenotic material removal mechanism, and an electrical monitor for monitoring the electrical conditions at the sensor electrode or electrodes. The electrical monitor may monitor the current leakage at the unipolar or bipolar sensor electrode to detect contact between the sensor electrode and a metallic stent and/or monitor the complex impedance across bipolar electrodes to detect proximity between the sensor electrodes and a metallic stent. The monitoring means may optionally include control means for deactivating the stenotic material removal mechanism when an unsafe condition that might lead to stent damage is detected or when the sensing means indicates an appropriate endpoint for the stenotic material removal process has been reached.

[0038] In an alternative embodiment, the monitoring means may be an optical sensor that includes an optical fiber which transmits a reference beam to a distal end of the catheter and directs it at the inner surface of the vessel close to the stenotic material removal mechanism. A photodetector detects the intensity and/or the wavelength of the light reflected back from the inner surface of the vessel through the optical fiber. A difference in reflectivity between the tissue of the vessel wall and the stent material allows the photodetector to detect proximity and/or contact between the stenotic material removal mechanism and the stent. In another alternative embodiment, the monitoring means may be a nonimaging, A mode ultrasonic scanner which generates a pulsed ultrasonic signal in a transducer mounted on or near the stenotic material removal mechanism. Differences in the acoustic impedance between the stent material and the arterial tissue or stenosis will cause echoes of the ultrasonic signal back to the transducer. The A mode ultrasonic scanner analyzes the amplitude and timing of the echoes detected by the ultrasonic transducer to measure the depth of the stent within the vessel wall. These two alternative embodiments of the monitoring means are useful for detection of both metallic and nonmetallic stents.

[0039] Preferably, each embodiment of the apparatus of the present invention will also include a motor drive unit which attaches at the proximal end of the catheter system. The motor drive unit houses a drive motor which is mechanically coupled to the inner catheter or the drive cable of the various embodiments to rotate and/or axially translate the stenotic material removal mechanism. For use with the first

four embodiments of the apparatus described above, the drive motor is preferably a motor or gear motor which operates at relatively low speed for rotating the various cutters at a speed from 500 to 2000 rpm. For use with the fifth embodiment of the apparatus described above, the drive motor is preferably a high speed motor which rotates the cutting head at a speed from 2000 to 150000 rpm for effective comminution of the stenotic material. Alternatively, the stenotic material removal mechanism may be operated by hand.

[0040] Optionally, the apparatus of the present invention may further comprise means for collecting and withdrawing the removed stenotic material from the blood vessel. The means for collection and withdrawal of the removed stenotic material may include an irrigation and/or aspiration apparatus attached respectively to the inner and outer catheters of the catheter assembly. Additionally, embolic filters or occlusion balloons may be included in the catheter system for placement upstream and/or downstream of the treatment site. An embolic filters and other stenotic material capture means are described for use in conjunction and/or in a combined apparatus with the stenotic material removal mechanism.

BRIEF DESCRIPTION OF THE DRAWINGS

[0041] FIG. 1 is a generalized schematic diagram of the apparatus of the present invention showing the different components of the catheter system.

[0042] FIG. 2 is a side view of the distal portion of a first embodiment of the apparatus of the present invention having a stenotic material removal mechanism having with a plurality of longitudinally oriented cutting blades shown in the contracted position.

[0043] FIG. 3 is a side view of the apparatus of FIG. 2 showing the stenotic material removal mechanism in the expanded position.

[0044] FIG. 4 is a distal end view of the apparatus of FIG. 2 with the stenotic material removal mechanism in the expanded position.

[0045] FIG. 5 is a magnified cutaway view of a cutting blade of the apparatus of FIG. 2 showing the sensor electrodes.

[0046] FIG. 6 is a cross section of the cutting blade of FIG. 5.

[0047] FIG. 7 is a side view of the distal portion of a second embodiment of the apparatus of the present invention having a stenotic material removal mechanism having with a plurality of helically configured cutting blades shown in the expanded position.

[0048] FIG. 8 is an enlarged distal end view of the apparatus of FIG. 7 with the stenotic material removal mechanism in the expanded position.

[0049] FIG. 9 is a magnified cutaway view of a cutting blade of the apparatus of FIG. 7 showing the sensor electrodes.

[0050] FIG. 10 is a cross section of the cutting blade of FIG. 9.

[0051] FIG. 11 is a side view of the distal portion and the proximal portion of a third embodiment of the apparatus of the present invention having a stenotic material removal mechanism with an extendible and retractable blade shown in the retracted position.

[0052] FIG. 12 is a side view of the apparatus of FIG. 11 showing the stenotic material removal mechanism in the extended position.

[0053] FIG. 13 is a magnified cross section of the cutting blade of the apparatus of FIG. 11 showing the sensor electrodes.

[0054] FIG. 14 is a side view of the distal portion of a fourth embodiment of the apparatus of the present invention showing a directional stenotic material removal mechanism with the balloon in the inflated position.

[0055] FIG. 15 is a top view of the apparatus of FIG. 14.

[0056] FIG. 16 is a side view of the distal portion and the proximal portion of a fifth embodiment of the apparatus of the present invention having an abrasive cutting head.

[0057] FIG. 17 is a magnified view of the cutting head of the apparatus of FIG. 16 showing the sensor electrodes.

[0058] FIGS. 18, 19, 20 and 21 are a series of drawings illustrating the method of the present invention using the apparatus of FIG. 2.

[0059] FIGS. 22, 23, 24 and 25 are a series of drawings illustrating an alternate method of the present invention using the apparatus of FIG. 2.

[0060] FIGS. 26, 27, 28 and 29 are a series of drawings illustrating another alternate method of the present invention using the apparatus of FIG. 2.

[0061] FIGS. 30, 31 and 32 are a series of drawings illustrating the operation of an optional embolic filter apparatus which may be used in conjunction with the method of the present invention.

[0062] FIGS. 33, 34, 35 and 36 are a series of drawings illustrating the operation of a combined stenotic material removal mechanism and stenotic material capture mechanism according to the present invention.

[0063] FIGS. 37, 38 and 39 are a series of drawings illustrating the operation of an alternate combined stenotic material removal mechanism and stenotic material capture mechanism according to the present invention.

[0064] FIG. 40 illustrates a kit including a catheter, a package and instructions for use according to the present invention.

DESCRIPTION OF THE SPECIFIC EMBODIMENTS

[0065] FIG. 1 is a generalized schematic diagram of the apparatus of the present invention. The apparatus comprises a catheter system designed to facilitate percutaneous removal of stenotic material from within a previously stented region of the vasculature without damaging or disrupting the implanted stent. In particular, the catheter system includes an inner catheter shaft 50 having a proximal end and a distal end, with a stenotic material removal mechanism 52 mounted near the distal end of the inner

catheter shaft 50 and a sensing means 54 for sensing when the stenotic material removal mechanism 52 is approaching or contacting the stent within the vascular wall. The inner catheter shaft 50 will preferably include a guidewire lumen for introduction of the catheter system over a steerable guidewire 56. The inner catheter shaft 50 may have additional lumens or actuating mechanisms associated with the stenotic material removal mechanism 52. Various embodiments of the stenotic material removal mechanism 52 will be more fully described below. In embodiments where the stenotic material removal mechanism 52 comprises resilient members which are radially compressible, the catheter system may also include an optional tubular sheath 58 which serves to maintain the stenotic material removal mechanism 52 in a compressed state as it is maneuvered to, and potentially across, the stenosis. The tubular sheath 58 may be split or scored along its length so that it can be easily removed from around the inner catheter shaft 50 and discarded after the stenotic material removal mechanism 52 has been maneuvered into place. The catheter system will usually further include an outer catheter tube 60 having a proximal end, a distal end and an inner lumen. The outer catheter tube will usually have a hemostasis valve 62 and an aspiration port 64 near its proximal end so that dislodged stenotic material can be aspirated from the vasculature. The outer catheter tube 60 may optionally have selective or subselective curves formed near the distal end of the outer catheter tube 60 for directing and maneuvering the catheter system through the vasculature to the site of the stenosis. In addition, an outer guiding catheter 66, for example a coronary guiding catheter, may be used for guiding the catheter system into the desired part of the vasculature and supporting it during the treatment. The guiding catheter 66 will have a Y-fitting with a hemostasis valve 68 connected at its proximal end.

[0066] Typically, the outer catheter 60 will have an overall length of approximately 60 cm to 120 cm, depending on the location of the vessel to be treated in the patient's body and the point of entry into the vasculature. For application in peripheral vessels or for application in the coronary arteries via a brachial artery insertion, the outer catheter 60 will typically have an overall length of approximately 60 cm to 90 cm. For application in the coronary arteries via a percutaneous femoral artery insertion, the outer catheter 60 will typically have an overall length of approximately 90 cm to 120 cm. The inner catheter 50 should have an overall length somewhat longer than the outer catheter 60 so that the stenotic material removal mechanism 52 can be extended out from the distal end of the outer catheter 60. The inner catheter 50 should therefore have an overall length of approximately 80 cm to 150 cm so that it can be extended 20 cm to 30 cm beyond the distal end of the outer catheter 60.

[0067] In a preferred embodiment, the catheter system includes a motor drive unit 70 which attaches at the proximal end of the inner catheter shaft 50. The motor drive unit 70 houses a drive motor 72 which is mechanically coupled to the inner catheter shaft 50 to rotate and/or axially translate the stenotic material removal mechanism 52 for removing stenotic material from within the stented vessel. The drive motor 72 may be a low speed motor or gear motor which operates at a speed from 500 to 2000 rpm or a high speed motor or a turbine which operates at a speed from 2000 to 150000 rpm. The operating speed of the drive motor 72 will

be chosen according to the particular needs of the stenotic material removal mechanism **52**, as will be discussed in more detail below. In alternative embodiments, the stenotic material removal mechanism **52** may be operated by hand.

[0068] The catheter system will also include a monitoring means **80** which couples to the sensor means **54** of the catheter system through a connection fitting **82** on the proximal end of the inner catheter shaft **50**. Typically, the connection fitting **82** will electrically couple to the monitoring means **80** through a commutator **84** which is part of the motor drive unit **70**. Alternatively, the monitoring means **80** may be miniaturized and incorporated as an integral part of the motor drive unit **70**. The monitoring means **80** may include an audible alarm **85** and a visual alarm **86** to indicate contact between the stenotic material removal mechanism **52** and the stent and/or a visual gauge **88** of the proximity of the stenotic material removal mechanism **52** to the stent. The structure and function of the sensor means **54** and the monitoring means **80** will be discussed in further detail below.

[0069] Optionally, the catheter system may further include an embolic filter **90** which may be coaxially deployed over the same guidewire **56** as the rest of the catheter system. Alternatively, embolic filters and/or occlusion balloons may be deployed on separate catheters for placement upstream and/or downstream of the treatment site.

[0070] The stenotic material removal mechanism which is disposed near the distal end of the inner catheter shaft may take one of several possible forms. The distal portion of a first illustrative embodiment of an inner catheter according to the apparatus of the present invention is depicted in FIGS. 2-6. In this embodiment, the stenotic material removal mechanism is in the form of a cutting head **100** having a plurality of longitudinally oriented cutting blades **102** arranged radially about the central axis of the inner catheter shaft **104**. The cutting head **100** is shown in a contracted position in FIG. 2 with the cutting blades **102** compressed closely around the central axis of the inner catheter shaft **104**. FIG. 3 shows the cutting head **100** in an expanded position with the cutting blades **102** extending radially outward from the central axis of the inner catheter shaft **104**. FIG. 4 shows a distal end view of the cutting head **100** in the expanded position. In variations of this embodiment, there may be two, three, four or more longitudinally oriented cutting blades **102**. Each of the cutting blades **102** is preferably shaped like a flattened wire with one or both lateral edges **110**, **112** of the wire sharpened into a cutting edge, as shown in the cross section of FIG. 6. The wire-shaped cutting blades **102** are resilient so that they can expand radially outward from the central axis of the inner catheter shaft **104**. Preferably, the wire-shaped cutting blades **102** maintain an approximately parallel orientation to one another as they expand and contract in the radial direction so that the overall configuration of the cutting head **100** is roughly cylindrical. The cutting blades **102** are preferably made of a strong and resilient biocompatible material capable of holding a sharp cutting edge. Suitable materials for the cutting blades **102** include metals, such as stainless steel, titanium and nickel/titanium alloys, and cobalt alloys like Elgiloy and MP35. Composite constructions are also possible for the cutting blades **102**.

[0071] The cutting head **100** can be passively expandable, in which case the resilient wire-shaped cutting blades **102**

are treated by coldworking or heat treatment to have an elastic memory that predisposes them to expand outward when they are released from the radial constraint of the tubular sheath **58** which was shown in FIG. 1. Alternatively, the cutting head **100** can be configured to be actively and controllably expandable. In this case, the resilient wire-shaped cutting blades **102** are attached on their proximal ends to the inner catheter shaft **104** and on their distal ends to an inner actuating member **106** which is coaxially slidably with respect to the inner catheter shaft **104**. When the inner actuating member **106** is moved proximally with respect to the inner catheter shaft **104**, the cutting blades **102** expand radially outward from the central axis of the inner catheter shaft **104**, and when the inner actuating member **106** is moved distally with respect to the inner catheter shaft **104**, the cutting blades **102** contract radially inward toward the central axis of the inner catheter shaft **104**. The cutting blades **102** may be treated by coldworking or heat treatment to have an elastic memory so that they are biased toward the contracted position so that the cutting head **100** will contract easily for advancing it across tight stenotic lesions, or toward a fully expanded position so that the cutting head **100** will be easy to deploy. Alternatively, the resilient wire-shaped cutting blades **102** may be treated so that they are biased toward an intermediate position which corresponds with a nominal expanded diameter. The inner actuating member **106** may be tubular, such as a polymer tube, a hollow flexible cable or a flexible metallic tube, so that a lumen **108** for a guidewire **56** can pass coaxially through the inner actuating member **106**. Alternatively, the inner actuating member may be a thin wire which runs parallel to and alongside the guidewire lumen.

[0072] The inner catheter shaft **104** is a tubular structure with an inner lumen **114** for passing the guidewire **56** and, in some embodiments, the inner actuating member **106** through. The inner catheter shaft **104** may be a polymer tube, a braid reinforced polymer tube, a hollow flexible cable, such as a multifilar wound cable, or a flexible metallic tube. The inner catheter shaft **104** acts as a flexible drive shaft for transmitting rotation and torque from the drive motor **72** (FIG. 1) to the cutting head **100**. The stenotic material removal mechanism is operated by rotating the cutting head **100** to remove the stenotic material from within the stent by the cutting action of the longitudinally oriented cutting blades **102**. The rotating action of the blades **102** may be accompanied by axially advancing or withdrawing the cutting head **100** through the stenosis and/or by expanding the width or diameter of the cutting head **100**. The cutting head **100** should be expandable over a range of approximately 2 mm to 5 mm for use in stented coronary arteries or as high as 6 mm for use in stented vein grafts and even larger for use in stented peripheral vessels and other stented body structures. The cutting head **100** should contract to as small a diameter as possible for passing through tightly stenotic lesions, preferably to a diameter smaller than 2 mm, more preferably to a diameter smaller than 1 mm. The effective cutting length of the cutting head **100** is preferably within the range of approximately 10 mm to 40 mm for use in stented coronary arteries and can be longer for use in stented peripheral vessels.

[0073] One or more, or all, of the longitudinally oriented cutting blades **102** includes a sensing means for sensing the proximity or contact between the cutting blades **102** and the stent. In this illustrative embodiment, the sensing means are

provided in the form of one or more electrode wires **116, 118** which are positioned on the cutting blades, as best seen in **FIGS. 5 and 6**. The sensing electrodes **116, 118** may extend the full length of the cutting blades **102** or only a portion of it, or the sensing electrodes **116, 118** may be arranged to provide a plurality of sensing locations along the length of the cutting blades **102**. In a first implementation of this embodiment, one or more open, exposed electrodes **116, 118** are located on the surface of the cutting blades **102**. Alternatively, the cutting blades **102** themselves may serve as the sensor electrodes. A direct or alternating current reference voltage is applied to a unipolar electrode or applied between two bipolar electrodes, and the current leakage of the electrode or electrodes is monitored. When one or more of the electrodes **116, 118** contacts the metallic stent, the leakage current increases indicating that the stenotic material has been removed down to the stent support members for effective recanalization of the stenosis within that portion of the stent. A second implementation of this embodiment involves two capacitively coupled bipolar electrodes **116, 118** which are located on the surface of the cutting blades **102**. An alternating current reference voltage is applied between the bipolar electrodes **116, 118**, and the complex impedance between the electrodes is monitored. As the electrodes **116, 118** approach the metallic stent, the capacitive and inductive characteristics of the electrode circuit change, which can be detected as a change in the complex impedance between the electrodes. When the complex impedance between the electrodes has changed a sufficient amount to indicate effective recanalization of the stenosis within that portion of the stent, the stenotic material removal mechanism may be deactivated or advanced along the stenosis as appropriate. These two implementations can be combined by applying an alternating current reference voltage between two exposed bipolar electrodes **116, 118**, and monitoring the complex impedance between the electrodes to indicate when the stenotic material removal mechanism is approaching the metallic stent, then when one or more of the electrodes contacts the metallic stent, it will ground to the stent which can be detected as an extreme change in the complex impedance or as a rise in the leakage current. Thus, the sensing means can be used to separately indicate proximity and contact between the cutting blades **102** and the stent. The sensing means can operate with very low voltage and current that will not create any adverse physiological effects on the vascular wall or the tissues and nerve pathways of the heart.

[0074] The distal portion of a second illustrative embodiment of an inner catheter according to the apparatus of the present invention is depicted in **FIGS. 7-10**. In this embodiment, the stenotic material removal mechanism is in the form of a cutting head **120** having a plurality of helically configured cutting blades **122** arranged radially about the central axis of the inner catheter shaft **124**, as shown in **FIG. 7**. **FIG. 8** shows an enlarged distal end view of the cutting head **120** in the expanded position. In variations of this embodiment, there may be two, three, four or more helically configured cutting blades **122**. Preferably, each of the cutting blades **122** is shaped like a flattened wire with one or both lateral edges **130, 132** of the wire sharpened into a cutting edge, as shown in the cross section of **FIG. 10**. Preferably, the helically configured cutting blades **122** maintain an approximately parallel orientation to one another as they expand and contract in the radial direction so that the overall

configuration of the cutting head **120** is roughly cylindrical. The cutting blades **122** are made of a strong and resilient biocompatible material capable of holding a sharp cutting edge, such as stainless steel, titanium and nickel/titanium alloys, and cobalt alloys like Elgiloy and MP35, or a composite construction.

[0075] As with the first embodiment, the cutting head **120** can be passively expandable or actively and controllably expandable. In the latter case, the helically configured cutting blades **122** are attached on their proximal ends to the inner catheter shaft **124** and on their distal ends to an inner actuating member **126** which slides proximally and distally with respect to the inner catheter shaft **124** to expand and contract diameter of the cutting head **120**, respectively. The cutting blades **122** may be treated by coldworking or heat treatment to have an elastic memory so that they are biased toward the contracted position, the expanded position or an intermediate position. The inner actuating member **126** may be tubular, such as a polymer tube, a hollow flexible cable or a flexible metallic tube, so that a lumen **128** for a guidewire **56** can pass coaxially through the inner actuating member **126**. Alternatively, the inner actuating member may be a thin wire which runs parallel to and alongside the guidewire lumen.

[0076] The inner catheter shaft **124** is a tubular structure with an inner lumen **134** for passing the guidewire **56** and, in some cases, the inner actuating member **126** through. The inner catheter shaft **124** may be a polymer tube, a braid reinforced polymer tube, a hollow flexible cable, such as a multifilar wound cable, or a flexible metallic tube that serves as a flexible drive shaft for transmitting rotation and torque from the drive motor **72** (**FIG. 1**) to the cutting head **120**. The stenotic material removal mechanism is operated by rotating the cutting head **120** to remove the stenotic material from within the stent by the cutting action of the helically configured cutting blades **122**. The rotating action of the blades **122** may be accompanied by axially advancing or withdrawing the cutting head **120** through the stenosis and/or by expanding the width or diameter of the cutting head **120**. The cutting head **120** should be expandable over a range of approximately 2 mm to 5 mm for use in stented coronary arteries or as high as 6 mm for use in stented vein grafts and even larger for use in stented peripheral vessels and other stented body structures. The cutting head **120** should contract to as small a diameter as possible for passing through tightly stenotic lesions, preferably to a diameter smaller than 2 mm, more preferably to a diameter smaller than 1 mm. The effective cutting length of the cutting head **120** is preferably within the range of approximately 10 mm to 40 mm for use in stented coronary arteries and can be longer for use in stented peripheral vessels.

[0077] One or more, or all, of the helically configured cutting blades **122** includes a sensing means for sensing the proximity or contact between the cutting blades **122** and the stent. As shown in **FIGS. 9 and 10**, the sensing means may be in the form of one or more electrode wires **136, 138** which are positioned on the surface of the cutting blades **122**. The sensing electrodes **136, 138** may extend the full length of the cutting blades **122** or only a portion of it, or the sensing electrodes **136, 138** may be arranged to provide a plurality of sensing locations along the length of the cutting blades **122**. As in the first embodiment described above, the electrodes **136, 138** may be exposed or insulated and unipolar or

bipolar. Alternatively, the cutting blades **122** themselves may serve as the sensor electrodes. Contact and/or proximity between the cutting blades **122** and the stent can be monitored by sensing the leakage current and/or the complex impedance of the sensor electrode circuit. When the sensing means detects sufficient proximity or contact between the cutting blades **122** and the stent to indicate effective recanalization of the stenosis within that portion of the stent, the cutting head **120** may be deactivated or advanced along the stenosis as appropriate.

[0078] The distal portion and the proximal portion of a third illustrative embodiment of an inner catheter according to the apparatus of the present invention is depicted in FIGS. **11-13**. In this embodiment, the stenotic material removal mechanism is in the form of a blade **140** which is extendible and retractable from within a cavity **142** located near the distal end of the inner catheter shaft **144**. The blade **140** is actuated to extend radially from the inner catheter shaft **144** by advancing an actuating member **146** which extends through an inner lumen **148** of the catheter to an advancement knob **152** which is located on a handle assembly **150** near the proximal end of the inner catheter shaft **144**. FIG. **11** is a side view of the inner catheter with the blade **140** on the distal portion of the inner catheter shaft **144** and the advancement knob **152** on the proximal handle assembly **150** in the retracted position. FIG. **12** is a side view of the inner catheter with the blade **140** and the advancement knob **152** in the extended position. Preferably, the blade **140** maintains an approximately parallel orientation to the inner catheter shaft **144** as it extends and retracts in the radial direction. The blade **140** may be treated by coldworking or heat treatment to have an elastic memory so that it is biased toward the retracted position, in which case the blade **140** will be extended by a compression force applied to the actuating member **146** by the advancement knob **152** on the handle assembly **150**. Alternatively, the blade **140** may be treated to be biased toward the extended position, in which case the blade **140** will be self-extending and will be retracted by a tensile force applied to the actuating member **146** by the advancement knob **152**. Accordingly, the actuating member **146** may be a thin wire, a flexible cable, or a thin tensile filament.

[0079] The inner catheter shaft **144** is a tubular structure with an inner lumen **162** which extends to the distal end for passing a guidewire **56** through for directing the catheter into and across a stented region in an artery. The inner catheter shaft **144** may be a polymer tube, a braid reinforced polymer tube, a hollow flexible cable, such as a multifilar wound cable, or a flexible metallic tube. Preferably, the inner catheter shaft **144** has sufficient torsional rigidity to serve as a flexible drive shaft for transmitting rotation and torque from the proximal handle assembly **150** to the blade **140** on the distal end of the inner catheter shaft **144**. The torque may be applied to the proximal handle assembly **150** manually by the operator or the proximal handle assembly **150** may include a drive motor **72**, as in FIG. **1**.

[0080] The stenotic material removal mechanism is operated by advancing the actuating member **146** to extend the blade **140** radially from the inner catheter shaft **144**, then rotating the catheter shaft **144** about its longitudinal axis to remove the stenotic material from within the stent. The rotating action of the blade **140** may be accompanied by axially advancing or withdrawing the inner catheter through

the stenosis. In one preferred embodiment, the stenotic material removal mechanism of the inner catheter operates by cutting action, in which case the blade **140** is preferably shaped like a flattened wire with one or both lateral edges **154, 156** of the wire sharpened into a cutting edge, as shown in the magnified cross section of the cutting blade in FIG. **13**. The cutting blade **140** is made of a strong and resilient biocompatible material capable of holding a sharp cutting edge, such as stainless steel, titanium and nickel/titanium alloys, and cobalt alloys like Elgiloy and MP35, or a composite construction. The cutting blade **140** includes a sensing means for sensing the proximity or contact between the cutting blade **140** and the stent. As shown in FIG. **13**, the sensing means may be in the form of one or more electrode wires **158, 160** which are positioned on the surface of the cutting blade **140**. The electrodes **158, 160** may be exposed or insulated and unipolar or bipolar. Alternatively, the cutting blade **140** itself may serve as a unipolar sensor electrode. Contact and/or proximity between the cutting blade **140** and the stent can be monitored by sensing the leakage current and/or the complex impedance of the sensor electrode circuit. When the sensing means detects sufficient proximity or contact between the cutting blade **140** and the stent to indicate effective recanalization of the stenosis within that portion of the stent, the cutting head **120** may be deactivated or advanced along the stenosis as appropriate.

[0081] Additionally or alternatively, energy, such as electrical, ultrasonic or thermal energy may be applied through the blade **140** to assist in removal of the stenotic material and/or for denaturing the remaining tissue to discourage further restenosis at the treatment site. In this case, electrodes used for heating or ablation can also serve as the sensing means electrodes for monitoring proximity or contact with the stent. If the device relies principally on ablation as the stenotic material removal technique, the blade **140** need not be sharpened as shown, but may instead be flat, round or any convenient shape.

[0082] The distal portion of a fourth illustrative embodiment of an inner catheter according to the apparatus of the present invention is depicted in FIGS. **14-15**. In this embodiment, the stenotic material removal mechanism **170** has a cutter **172** positioned within a housing **174**. The housing **174** has a side aperture **176** which exposes the cutter **172** and an inflatable balloon **180** located on the back of the housing **174** opposite the side aperture **176**. The balloon **180** can be inflated with fluid injected through a balloon lumen **182** to increase the width or diameter of the stenotic material removal mechanism **170** and thereby to control the depth of cut and the diameter of the blood flow channel created. The balloon **180** may be made of polyethylene, polyester, nylon or other polymeric materials. The cutter **172** may be a cup-shaped rotating blade, a rotating linear or helical blade, a rotating abrasive burr or an axially movable cutting blade, which is rotated and/or translated by a drive shaft **178** that extends proximally through a lumen **186** within the catheter shaft **184**. Additionally or alternatively, medications, chemicals, ionizing radiation or energy, such as electrical, magnetic, ultrasonic, hydraulic, pulsed hydraulic, laser or thermal energy may be applied through the cutter **172** to assist in removal of the stenotic material and/or for denaturing the remaining tissue to discourage further restenosis at the treatment site.

[0083] The catheter shaft **184** is a tubular structure which includes the balloon lumen **182** and the drive shaft lumen **186**. The catheter shaft **184** may be a polymer tube, a braid reinforced polymer tube, a hollow flexible cable, such as a multifilar wound cable, or a flexible metallic tube. Preferably, the catheter shaft **184** has sufficient torsional rigidity to rotate the housing **174** on the distal end of the catheter by rotating the proximal end of the catheter shaft **184**. The drive shaft **178** may be a hollow tube with a guidewire lumen **190** which extends to the distal end for passing a guidewire **56** through for directing the catheter into and across a stented region in an artery. The drive shaft **178** may be a polymer tube, a braid reinforced polymer tube, a hollow flexible cable, such as a multifilar wound cable, or a flexible metallic tube. Alternatively, the drive shaft **178** may be a solid wire, in which case the guidewire lumen **190** could be a separate lumen within the catheter shaft **184**.

[0084] In operation, the stenotic material removal mechanism **170** is positioned by advancing and rotating the inner catheter so that the side aperture **176** of the housing **174** is situated across the stenosis within the stent and inflating the balloon **180** to press the side aperture **176** against the stenotic material. Then, the cutter **172** is actuated by rotating and/or by axially advancing the cutter **172** within the housing **174** to remove stenotic material from within the stent. A sensing means **188, 188'** for sensing the proximity or contact between the stenotic material removal mechanism **170** and the stent is positioned on the cutter **172** and/or the housing **174** of the catheter. Again, the sensing means **188, 188'** may be in the form of one or more electrode wires which are positioned on the cutter **172** and/or the housing **174**. If the stenotic material removal mechanism **170** operates by electrical or thermal heating or ablation, the heating or ablation electrodes can also serve as the sensing means electrodes for monitoring proximity or contact with the stent. When the sensing means detects sufficient proximity or contact between the cutter **172** and the stent to indicate the desired depth of cut, the cutter **172** is deactivated and withdrawn or directed to another part of the stenosis within the stented portion of the vessel.

[0085] The distal portion of a fifth illustrative embodiment of an inner catheter according to the apparatus of the present invention is depicted in FIGS. 16-17. In this embodiment, the stenotic material removal mechanism is rotatably and slidably received within an inner lumen **212** of the inner catheter shaft **210**. The stenotic material removal mechanism has a rotating cutting head **200** attached to a hollow drive cable **202** which is coaxially and rotatably positioned over a guidewire **204**. The rotating cutting head **200** is typically spherical or ovoid in shape and has cutting blades, teeth or abrasive particles **206** on its exterior surface. In one preferred embodiment, the cutting head **200** has minute diamond abrasive particles **206** embedded on its exterior surface. The hollow drive cable **202** is preferably a multifilar wound cable, but alternatively may be a polymer tube, a braid reinforced polymer tube, a hollow flexible cable or a flexible metallic tube. Optionally, the inner catheter shaft **210** and/or the guidewire **204** may have a bend **214, 216** or other steering mechanism close to its distal end for directing the cutting head **200** against the stenotic material within the stent. Alternatively or additionally, the cutting head **200** may also have control means for adjusting the outer diameter of the cutting head **200**. Suitable cutting head diameter control

means are described in U.S. Pat. Nos. 5,217,474 and 5,308,354, the specifications of which are hereby incorporated by reference in their entirety.

[0086] A sensing means for sensing the proximity or contact between the cutting head **200** and the stent is positioned on the cutting head **200**. The sensing means may be in the form of one or more electrodes **218, 220** which are positioned on the cutting head **200**. One or more electrode lead wires **222, 224** may be incorporated into the multifilar hollow drive cable **202**. The electrodes **218, 220** may be exposed or insulated and unipolar or bipolar. Alternatively, the cutting head **200** itself may serve as a unipolar sensor electrode and the multifilar hollow drive cable **202** may serve as a single electrode lead wire.

[0087] The stenotic material removal mechanism is operated by advancing the inner catheter so that the cutting head **200** is positioned within the stenosis, then rotating the drive cable **202** and the cutting head **200** to remove stenotic material from within the stent. Preferably, the cutting head **200** is rotated with a high speed motor or turbine which rotates the cutting head at a speed from 2000 to 150000 rpm. The rotating action of the cutting head **200** may be accompanied by axially advancing or withdrawing the cutting head **200** through the stenosis. The cutting blades, teeth or abrasive particles **206** on the exterior surface of the cutting head **200** comminute, or pulverize, the stenotic material into fine particles that will not cause embolization downstream of the treatment site. The optional bend **214, 216** or steering mechanism of the inner catheter **210** or guidewire **204** may be used for directing the cutting head **200** against the stenotic material within the stent. Alternatively, the control means may be used for adjusting the diameter of the cutting head **200** to achieve effective recanalization of the stented artery. When the sensing means indicates sufficient proximity or contact between the cutting head **200** and the stent, the cutting head **200** is deactivated and withdrawn or advanced and directed to another part of the stenosis within the stented portion of the vessel.

[0088] The function of the monitoring means **80** of the catheter system, shown generically in FIG. 1, will be more fully appreciated in light of the foregoing descriptions of the various embodiments of the stenotic material removal mechanism and their related sensing means. In one preferred embodiment, the monitoring means includes a voltage source that generates a direct or alternating current reference voltage which is applied to a unipolar electrode or applied between two bipolar electrodes positioned on the stenotic material removal mechanism, and an electrical monitor for monitoring the electrical conditions at the sensor electrode or electrodes. The electrical monitor may monitor the current leakage at the unipolar or bipolar sensor electrode to detect contact between the sensor electrode and a metallic stent and/or monitor the complex impedance across bipolar electrodes to detect proximity between the sensor electrodes and a metallic stent. The monitoring means may optionally include control means for deactivating the stenotic material removal mechanism when an unsafe condition that might lead to stent damage is detected or when the sensing means indicates that an appropriate endpoint for the stenotic material removal process has been reached.

[0089] In cases where the sensing means provides separate sensing electrodes on the different blades of the stenotic

material removal mechanism or where a plurality of sensing locations are provided along the length of the stenotic material removal mechanism, the monitoring means **80** can be designed to monitor each of the multiple electrodes or sensing locations simultaneously, or it can be designed to have an appropriate sampling rate for alternately monitoring each of the electrodes or sensing locations in sequence.

[0090] In an alternative embodiment, the monitoring means may be an optical sensor that includes an optical fiber which transmits a reference beam to a distal end of the catheter and directs it at the inner surface of the vessel close to the stenotic material removal mechanism. A photodetector detects the intensity and/or the wavelength of the light reflected back from the inner surface of the vessel through the optical fiber. A difference in reflectivity between the tissue of the vessel wall and the stent material allows the photodetector to detect proximity and/or contact between the stenotic material removal mechanism and the stent.

[0091] In another alternative embodiment, the monitoring means may be a nonimaging, A mode ultrasonic scanner which generates a pulsed ultrasonic signal in a transducer mounted on or near the stenotic material removal mechanism. Differences in the acoustic impedance between the stent material and the arterial tissue or stenosis will cause echoes of the ultrasonic signal back to the transducer. The A mode ultrasonic scanner analyzes the amplitude and timing of the echoes detected by the ultrasonic transducer to measure the depth of the stent within the vessel wall. These two alternative embodiments of the monitoring means are useful for detection of both metallic and nonmetallic stents. A nonimaging, A mode ultrasonic scanner of this type is much more economical than the imaging ultrasonic scanners which have been described in combination with various atherectomy devices. The high echogenicity of the stent material will give a reliable measure of the depth of the stent within the vessel wall without the need for expensive imaging equipment.

[0092] FIGS. 18, 19, 20 and 21 are a series of drawings illustrating the method of the present invention. The method is illustrated and described using the apparatus of FIG. 1 with the stenotic material removal mechanism of FIGS. 2-6 by way of example. This method may be applied using any of the various apparatus described above with minor modifications to the procedure. The catheter system of FIG. 1 is introduced into the patient's vascular system through a peripheral arterial access using the known techniques of an arterial cutdown, the Seldinger technique and/or an introducer sheath. The catheter system is maneuvered to the vicinity of a restenosed region within a previously stented region of the vasculature, for example within a coronary artery, using manipulations of the optional guiding catheter **66** and the outer catheter **60** of the catheter system. The inner catheter **50** carrying the stenotic material removal mechanism **52** is positioned on one side of the restenosed stented region and the steerable guidewire **56** is maneuvered across the stenosis.

[0093] Referring now to FIG. 18, the cutting head **100** of the stenotic material removal mechanism is advanced from the inner catheter in the contracted position and positioned across the stenosis **S** within the stent **T**. The cutting head **100** is then expanded within the stenosis **S**, as shown in FIG. 19. The expansion may occur passively, by withdrawing the

optional tubular sheath **58** (shown in FIG. 1) and allowing the resilient cutting blades **102** of the cutting head **100** to expand outward. Alternatively, the expansion may occur actively and controllably, by withdrawing the inner actuating member **106** to expand the cutting blades **102** outward and increase the width or diameter of the cutting head **100**. The stenotic material removal mechanism is then activated by rotating the cutting head **100** to remove the stenotic material **M** from within the stenosis **S**. The cutting head **100** may be manually rotated by the operator or by a drive motor **72** within a motor drive unit **70**, as shown in FIG. 1. Medications, chemicals, ionizing radiation or energy, such as electrical, magnetic, ultrasonic, hydraulic, pulsed hydraulic, laser or thermal energy may be applied to assist in removal of the stenotic material **M** and/or for denaturing the remaining tissue to discourage further restenosis at the treatment site. The stenotic material **M** that is removed may be aspirated out through the aspiration port **64** of the outer catheter **60** (shown in FIG. 1). The electrodes **116**, **118** of the sensing means located on the cutting blades **102** monitor the proximity or contact between the cutting head **100** and the stent **T**. When the cutting blades **102** have approached close enough to the stent **T** to indicate effective recanalization of the stenosis **S**, as shown in FIG. 20, the stenotic material removal mechanism is deactivated. The catheter system is then withdrawn, leaving the stented region recanalized and open to renewed blood flow, as shown in FIG. 21.

[0094] FIGS. 22, 23, 24 and 25 are a series of drawings illustrating an alternate method of the present invention. As above, the method is illustrated and described using the stenotic material removal mechanism of FIGS. 2-6, but the method may be applied using most of the various apparatus described above with minor modifications to the procedure. In this alternative method, the catheter carrying the stenotic material removal mechanism is positioned on one side of the restenosed stented region. The cutting head **100** of the stenotic material removal mechanism is extended from the catheter and advanced part-way into the stent **T** and the cutting blades **102** are expanded outward, as shown in FIG. 22. The electrodes **116**, **118** of the sensing means located on the cutting blades **102** monitor the proximity or contact between the cutting head **100** and the stent **T** so that the diameter of the cutting head **100** can be accommodated to the internal diameter of the stent **T**. If the stenosis **S** does not extend all of the way to the end of the stent **T**, the expansion step can be performed while the cutting head **100** is stationary. However, if necessary, the stenotic material removal mechanism can be activated by rotating the cutting head **100** as the cutting blades **102** expand outward to begin removing the stenotic material **M** while adjusting the diameter of the cutting head **100** to the size of the stent **T**.

[0095] The stenotic material **M** is removed from within the stent **T** by rotating the cutting head **100** and advancing it through the stenosis **S**, as shown in FIGS. 23 and 24. The diameter of the cutting head **100** can be held constant as it is advanced through the stenosis **S** or it can be adjusted continuously based on feedback from the sensing means. Medications, chemicals, ionizing radiation or energy, such as electrical, magnetic, ultrasonic, hydraulic, pulsed hydraulic, laser or thermal energy may be applied to assist in removal of the stenotic material **M** and/or for denaturing the remaining tissue to discourage further restenosis at the treatment site. The stenotic material **M** that is removed may be aspirated out through the aspiration port **64** of the outer

catheter **60** (shown in **FIG. 1**). When the cutting head **100** has passed all the way through the stenosis **S**, the stenotic material removal mechanism is deactivated and the catheter system is withdrawn, leaving the stented region recanalized and open to renewed blood flow, as shown in **FIG. 25**.

[0096] This method can be effectively performed in the reverse direction, by advancing the cutting head **100** all the way across the stenosis in a contracted or compressed state. The cutting head **100** is then expanded within the far end of the stenosis **S** or within the vessel beyond the stenosis, using the sensing means to adjust the diameter of the cutting head **100** to the size of the stent **T**. The cutting head **100** is then rotated while withdrawing it toward the catheter to advance it through the stenosis **S**.

[0097] **FIGS. 26, 27, 28** and **29** are a series of drawings illustrating another alternate method of the present invention. Once again, the method is illustrated and described using the stenotic material removal mechanism of **FIGS. 2-6**, but the method may be applied using most of the various apparatus described above with minor modifications to the procedure. In this alternative method, the catheter carrying the stenotic material removal mechanism is positioned on one side of the restenosed stented region. The cutting head **100** of the stenotic material removal mechanism is extended from the catheter and advanced part-way into the stenosis **S** within the stent **T**, as shown in **FIG. 26**. The cutting blades **102** are then expanded outward within the stenosis **S**, either passively or actively and controllably as described above, to increase the width or diameter of the cutting head **100**. The stenotic material removal mechanism is then activated by rotating the cutting head **100** to begin removing the stenotic material **M** from within the stenosis **S**, as shown in **FIG. 27**. Medications, chemicals, ionizing radiation or energy, such as electrical, magnetic, ultrasonic, hydraulic, pulsed hydraulic, laser or thermal energy may be applied to assist in removal of the stenotic material **M** and/or for denaturing the remaining tissue to discourage further restenosis at the treatment site. The stenotic material **M** that is removed may be aspirated out through the aspiration port **64** of the outer catheter **60** (shown in **FIG. 1**). The electrodes **116, 118** of the sensing means located on the cutting blades **102** monitor the proximity or contact between the cutting head **100** and the stent **T**. When the cutting blades **102** have approached close enough to the stent **T** to indicate effective recanalization of that portion of the stenosis **S**, the cutting head **100** is advanced farther into the stenosis **S**, as shown in **FIG. 28**. The stenotic material removal mechanism may be deactivated and advanced step-wise into the stenosis **S** by contracting or compressing the cutting head **100**, advancing it a short distance and expanding it again in a new portion of the stent **T**. Otherwise, the cutting head **100** may be advanced continuously, relying on either the resiliency of the cutting blades **102** or active control for adjusting the width or diameter of the cutting head **100** as it advances. When the sensing means indicates that the new portion of the stent **T** has been effectively recanalized, the cutting head **100** is advanced again along the stenosis **S** until the entire stented region has been recanalized, as shown in **FIG. 29**.

[0098] This method can be effectively performed in the reverse direction, by advancing the cutting head **100** all the way across the stenosis in a contracted or compressed state. The cutting head **100** is then expanded within the far end of the stenosis **S** or within the vessel beyond the stenosis, either

passively or actively and controllably as described above, to increase the width or diameter of the cutting head **100**. The cutting head **100** is then rotated while withdrawing it toward the catheter to advance it through the stenosis in either a step-wise or continuous fashion. Medications, chemicals, ionizing radiation or energy, such as electrical, magnetic, ultrasonic, hydraulic, pulsed hydraulic, laser or thermal energy may be applied to assist in removal of the stenotic material and/or for denaturing the remaining tissue to discourage further restenosis at the treatment site. The sensing means is used to monitor the proximity or contact between the cutting head **100** and the stent **T** in order to control the diameter and/or the rate of advancement of the cutting head **100** for effective recanalization of the stenosis **S** within the stent **T**.

[0099] The methods of the present invention will optionally further comprise collecting and withdrawing the removed stenotic material from the blood vessel. **FIGS. 30, 31** and **32** are a series of drawings illustrating the operation of an optional embolic filter apparatus **90** which may be used in conjunction with the method of the present invention. The embolic filter apparatus **90** may be arranged coaxially as part of the catheter system as shown in **FIG. 1** and introduced through a single vascular access point and positioned distally to the treatment site. Alternatively, embolic filter apparatus **90** may be arranged on a separate catheter which is introduced through a different vascular access point and positioned proximally or distally to the treatment site.

[0100] In **FIG. 30**, the embolic filter **90** is shown in its compacted position within a tubular sheath **92** as it is first introduced into the vasculature and advanced to or across the stenosis. In coaxial arrangements, the tubular sheath **92** may be the same as the tubular sheath **58** or the inner catheter **50** of the catheter system of **FIG. 1**. The embolic filter **90** may be delivered coaxially over a separate guidewire **56**, or it may be built integrally with a guidewire **56** constructed especially for the purpose. Once the embolic filter **90** is in position, the tubular sheath **92** is withdrawn and the embolic filter **90** is allowed to expand to the full diameter of the vessel, as shown in **FIG. 31**. The expansion can occur passively, or an actuation member **94** may be used to actively expand the embolic filter **90**. The embolic filter **90** should be expandable over a range of approximately 2 mm to 5 mm for use in stented coronary arteries or as high as 6 mm for use in stented vein grafts and even larger for use in stented peripheral vessels and other stented body structures. The embolic filter **90** should contract to as small a diameter as possible for passing through tightly stenotic lesions, preferably to a diameter smaller than 2 mm, more preferably to a diameter smaller than 1 mm. The embolic filter **90** has a plurality of structural members **96**, which enclose and support a nonthrombogenic expandable filter medium **98**. The structural members **96** can be made of a metallic or polymeric material, and may be biased radially outward to assist in expansion of the embolic filter **90**. The expandable filter medium **98** may be a porous foam material or it may be a fibrous filter medium such as polyester fiber, which, in its expanded state, has a pore size appropriate for capturing significant emboli which may be dislodged during the stenotic material removal process. The pore size of the expandable filter medium **98** may advantageously be in the range of 0.01 to 0.2 mm to capture potential emboli. Once the stenotic material removal procedure has been completed, the embolic filter **90** is compressed slightly, by passive or

active means, and withdrawn into an outer catheter 99, to capture the emboli without releasing them, as shown in FIG. 32. In coaxial arrangements, the outer catheter 99 may be the inner catheter 50 or outer catheter 60 of the catheter system of FIG. 1. The outer catheter 99 and the embolic filter 90 are then withdrawn from the patient's vasculature. In other alternative methods, embolic filters and/or occlusion balloons may be placed upstream and downstream of the treatment site to isolate or capture potential emboli.

[0101] FIGS. 33, 34, 35 and 36 are a series of drawings illustrating a method and an apparatus according to the present invention that combine a stenotic material removal mechanism with an embolic filter for capturing stenotic material M which is removed from within the stent T. The apparatus has a cutting head 300 which is mounted on the distal end of an inner catheter shaft 302. The cutting head 300 has a cutting portion 304 and a filtering or material capturing portion 306. In this illustrative embodiment, the cutting portion 304 is centrally located on the cutting head 300 and the material capturing portion 306 is located distal to it. The cutting head 300 should be expandable over a range of approximately 2 mm to 5 mm for use in stented coronary arteries or as high as 6 mm for use in stented vein grafts and even larger for use in stented peripheral vessels and other stented body structures. The cutting head 300 should contract to as small a diameter as possible for passing through tightly stenotic lesions, preferably to a diameter smaller than 2 mm, more preferably to a diameter smaller than 1 mm. The effective cutting length of the cutting portion 304 is preferably within the range of approximately 10 mm to 40 mm for use in stented coronary arteries and can be longer for use in stented peripheral vessels. Additionally or alternatively, the cutting head 300 may also include a second material capturing portion 306' located proximally to the cutting portion 304. Alternatively, the material capturing portion 306 may occupy the entire length of the cutting head 300. The cutting portion 304 of the cutting head 300 may take any one of the different forms described herein in connection with the various embodiments of the invention. For illustrative purposes, the cutting portion 304 is shown having a plurality of longitudinally oriented cutting blades 308, similar to those shown in FIGS. 2-6. Alternatively, the cutting blades may be laterally or circumferentially oriented or helically configured, similar to those shown in FIGS. 7-10, or any convenient geometry. The cutting blades 308 of the cutting head 300 may be either passively or actively expandable, as described above.

[0102] The material capturing portion 306 preferably contains a nonthrombogenic expandable filter medium 310. The expandable filter medium 310 may be a porous foam material or it may be a fibrous filter medium such as polyester fiber, which, in its expanded state, has a pore size appropriate for capturing significant emboli which may be dislodged during the stenotic material removal process. The pore size of the expandable filter medium 310 may advantageously be in the range of 0.01 to 0.2 mm to capture potential emboli. The expandable filter medium 310 is enclosed and supported by the cutting blades 308 of the cutting head 300. Additionally or alternatively, the expandable filter medium 310 may include a membranous filter material that is attached to and suspended between the cutting blades 308 of the cutting head 300. Suitable membranous filter materials include flexible woven, nonwoven or knitted filtration fabrics. The expandable filter medium 310 occupies a distal portion 306

and/or a proximal portion 306' of the cutting head 300. Alternatively, the expandable filter medium 310 may occupy the entire length of the cutting head 300.

[0103] In use, the catheter carrying the stenotic material removal mechanism is positioned on one side of the restenosed stented region. The cutting head 300 is extended from the catheter and advanced across the stenosis S in the contracted position, as shown in FIG. 33. The expandable filter medium 310 is compressed within the cutting head 300. The cutting head 300 is then expanded within the stenosis S, as shown in FIG. 34. The expansion may occur passively, by withdrawing a surrounding tubular sheath 58 (shown in FIG. 1) and allowing the resilient cutting blades 308 of the cutting head 300 to expand outward. Alternatively, the expansion may occur actively and controllably, by operating an actuating mechanism to expand the cutting blades 308 outward and increase the width or diameter of the cutting head 300, as described above in connection with FIGS. 2-6. Preferably, the filter medium 310 within the material capturing portion 306 of the cutting head 300 expands to a diameter at least as large or larger than the expanded diameter of the cutting portion 304 of the cutting head 300. The stenotic material removal mechanism is then activated by rotating the cutting head 300 to remove the stenotic material M from within the stenosis S. The cutting head 300 may be rotated manually by the operator or by a drive motor 72 within a -motor drive unit 70, as shown in FIG. 1. Medications, chemicals, ionizing radiation or energy, such as electrical, magnetic, ultrasonic, hydraulic, pulsed hydraulic, laser or thermal energy may be applied to assist in removal of the stenotic material M and/or for denaturing the remaining tissue to discourage further restenosis at the treatment site. The stenotic material M that is removed is captured by the filter medium 310 within the material capturing portion 306 of the cutting head 300, as shown in FIG. 35.

[0104] Preferably, the cutting head 300 includes a sensing means, such as the sensor electrodes 116, 118 described above in connection with FIGS. 5 and 6, for sensing the proximity or contact between the cutting blades 308 of the cutting head 300 and the stent T. When the cutting blades 308 have approached close enough to the stent T to indicate effective recanalization of the stenosis S, as shown in FIG. 35, the stenotic material removal mechanism is deactivated. The cutting head 300 and all of the stenotic material M captured by the filter medium 310 within the material capturing portion 306 of the cutting head 300 are then withdrawn into the outer catheter 60, as shown in FIG. 36. The catheter system is then withdrawn from the patient, leaving the stented region recanalized and open to renewed blood flow.

[0105] Alternatively, this cutting head 300 with a combined stenotic material removal mechanism and stenotic material capture mechanism may be operated as a simple shearing body without a sensing means. In this alternative method, the cutting head 300 may be rotated and/or translated within the stenosis S to dislodge stenotic material M from within an interface envelope defined by the stent T embedded within the vessel wall, as shown in FIG. 34. The cutting head 300 may be expanded passively or actively to remove all of the stenotic material M from within the stent T. The stenotic material M that is removed is captured by the filter medium 310 within the material capturing portion 306

of the cutting head **300**, as shown in **FIG. 35**. The cutting head **300** and all of the stenotic material **M** captured by the filter medium **310** within the material capturing portion **306** of the cutting head **300** are then withdrawn into the outer catheter **60**, as shown in **FIG. 36**.

[**0106**] **FIGS. 37, 38** and **39** are a series of drawings illustrating an alternate method and apparatus according to the present invention that also combine a stenotic material removal mechanism with a means for capturing the stenotic material **M** that is removed from within the stent **T**. The apparatus has a head **350** which is mounted on the distal end of an inner catheter shaft **352**. The head **350** is a cage-like structure of counterwound or interwoven helical elements **356**. The helical elements **356** may comprise round filaments, ribbon filaments, or the like, made of a metallic or polymeric material. The helical elements **356** are attached to a distal ring **358** and to a proximal ring **360** which is free to slide over the inner catheter shaft **352**. The helical elements **356** may be treated by coldworking or heat treatment to have an elastic memory so that they are biased toward the expanded position, allowing the head **350** to be passively expanded. Alternatively, the proximal ring **360** may optionally be attached to a rod, sleeve, or other means **362** for axially translating the proximal ring **360** to actively and controllably adjust the radius of the head **350**. The cage-like structure of counterwound or interwoven helical elements **356** serves to capture dislodged stenotic material **M** that passes through the interstices between the helical elements **356**.

[**0107**] In use, the catheter **60** carrying the stenotic material removal mechanism is positioned on one side of the restenosed stented region. The head **350** is extended from the catheter and advanced across the stenosis **S** in a contracted position, as shown in **FIG. 37**. The head **350** is then expanded within the stenosis **S**, either passively or actively and controllably as described above. The stenotic material removal mechanism is then activated by rotating and/or translating the head **350** within the stenosis **S** to remove stenotic material **M** from within the stent **T**, as shown in **FIG. 38**. The head **350** may be rotated manually by the operator or by a drive motor **72** within a motor drive unit **70**, as shown in **FIG. 1**. The head **350** may operate by cutting action, abrasive action or shearing action. Alternatively or additionally, medications, chemicals, ionizing radiation or energy, such as electrical, magnetic, ultrasonic, hydraulic, pulsed hydraulic, laser or thermal energy may be applied to assist in removal of the stenotic material **M** and/or for denaturing the remaining tissue to discourage further restenosis at the treatment site. The stenotic material **M** that is dislodged passes through the interstices between the helical elements **356** and is captured within the cage-like structure of the head **350**.

[**0108**] Preferably, the head **350** includes a sensing means for sensing the proximity or contact between the helical elements **356** of the head **350** and the stent **T**. As shown in **FIG. 38**, the sensing means may take the form of one or more sensor electrode wires **366, 368** interwoven among the helical elements **356** of the head **350**. Alternatively, the helical elements **356** of the head **350** may serve as sensor electrodes themselves. When the helical elements **356** of the head **350** have approached close enough to the stent **T** to indicate effective recanalization of the stenosis **S**, as shown in **FIG. 38**, the stenotic material removal mechanism is

deactivated. The head **350** and all of the stenotic material **M** captured within the cage-like structure of the helical elements **356** are then withdrawn into the outer catheter **60**, as shown in **FIG. 39**. The interstices between the helical elements **356** of the head **350** contract as the head **350** is drawn into the catheter **60**, helping to assure that the particles of dislodged stenotic material **M** remain captured within the catheter. The catheter system is then withdrawn from the patient, leaving the stented region recanalized and open to renewed blood flow.

[**0109**] Alternatively, the head **350** of this apparatus may be operated as a simple shearing body without a sensing means. In this alternative method, the head **350** may be rotated and/or translated within the stenosis **S** to dislodge stenotic material **M** from within an interface envelope defined by the stent **T** embedded within the vessel wall, as shown in **FIG. 38**. The head **350** may be expanded passively or actively to remove all of the stenotic material **M** from within the stent **T**. The stenotic material **M** that is dislodged passes through the interstices between the helical elements **356** and is captured within the cage-like structure of the head **350**. The head **350** and all of the stenotic material **M** captured within it are then withdrawn into the outer catheter **60**, as shown in **FIG. 39**.

[**0110**] Referring now to **FIG. 40**, a catheter kit according to the present invention comprises a catheter or catheter system **370**, often mounted on a board or in a tray **372**, instructions for use (IFU) **374**, and a pouch **376** or other conventional package. A motor drive unit **70** (**FIG. 1**) may be packaged together with the catheter kit or separately. The instructions for use (IFU) **374** are typically part of a separate sheet or booklet which together with the catheter **370**, is packaged within the pouch **376** or other packaging material. The packaging and its contents will preferably be sterile or sterilizable. The instructions for use (IFU) **374** will set forth method steps comprising the method(s) as described above.

[**0111**] Although the method of the present invention has been described using the example of revascularizing restenosed coronary arteries, it should be noted that the methods and apparatus disclosed may be used for reopening any previously stented body passage which has been subject to restenosis or reclosure. Other body passages where these methods and apparatus may apply include the peripheral blood vessels, the urinary tract, the digestive tract and the respiratory tract.

What is claimed is:

1. An apparatus for removing stenotic material from within a stent located within a body vessel, said apparatus comprising:

a stenotic material removal mechanism for removing stenotic material from within the stent,

sensor means associated with said stenotic material removal mechanism for sensing proximity or contact between said stenotic material removal mechanism and the stent,

whereby said sensor means is used to determine an unsafe condition or an appropriate endpoint for removal of stenotic material from within the stent based on the sensed proximity or contact between said stenotic material removal mechanism and the stent for effective recanalization of the body vessel.

2. The apparatus of claim 1 further comprising a control means for controlling a depth to which said stenotic material removal mechanism removes the stenotic material from within the stent.

3. The apparatus of claim 2 wherein said control means comprises a mechanism for diametrically expanding said stenotic material removal mechanism.

4. The apparatus of claim 1 further comprising a means for directing said stenotic material removal mechanism to remove stenotic material from a selected area within the stent.

5. The apparatus of claim 1 further comprising a means for diametrically expanding said stenotic material removal mechanism.

6. The apparatus of claim 1 wherein said stenotic material removal mechanism comprises at least one longitudinally oriented blade.

7. The apparatus of claim 1 wherein said stenotic material removal mechanism comprises a plurality of longitudinally oriented blades.

8. The apparatus of claim 7 wherein said longitudinally oriented blades are resiliently biased to expand radially outward from a central axis of said stenotic material removal mechanism.

9. The apparatus of claim 1 wherein said stenotic material removal mechanism comprises a plurality of helically configured blades.

10. The apparatus of claim 9 wherein said helically configured blades are resiliently biased to expand radially outward from a central axis of said stenotic material removal mechanism.

11. The apparatus of claim 1 wherein said stenotic material removal mechanism comprises a rotating blade.

12. The apparatus of claim 1 wherein said stenotic material removal mechanism comprises a rotating abrasive tool.

13. The apparatus of claim 1 wherein said stenotic material removal mechanism comprises a cage-like network of filaments.

14. The apparatus of claim 1 further comprising a monitoring means associated with said sensor means for monitoring the proximity or contact between said stenotic material removal mechanism and the stent.

15. The apparatus of claim 14 wherein said sensor means comprises at least one electrical conductor on an exterior of said apparatus and said monitoring means comprises a leakage current detector for detecting a leakage current when said at least one electrical conductor contacts said stent.

16. The apparatus of claim 14 wherein said sensor means comprises a first electrical conductor and a second electrical conductor on an exterior of said apparatus and said monitoring means comprises a leakage current detector for detecting a leakage current when said first electrical conductor and said second electrical conductor contacts said stent.

17. The apparatus of claim 14 wherein said sensor means comprises at least one electrical conductor within said apparatus and said monitoring means comprises a means for detecting a change in electrical impedance when said at least one electrical conductor approaches said stent.

18. The apparatus of claim 14 wherein said sensor means comprises a first electrical conductor and a second electrical conductor within said apparatus and said monitoring means comprises a means for detecting a change in electrical

impedance when said first electrical conductor and said second electrical conductor approach said stent.

19. The apparatus of claim 14 wherein said monitoring means produces a signal indicative of the proximity or contact between said stenotic material removal mechanism and the stent.

20. The apparatus of claim 14 wherein said monitoring means includes means for deactivating said stenotic material removal mechanism when a predetermined level of proximity or contact between said stenotic material removal mechanism and the stent is detected.

21. The apparatus of claim 1 wherein said stenotic material removal mechanism is positioned at a distal portion of a first elongated catheter shaft.

22. The apparatus of claim 21 wherein said first elongated catheter shaft includes a lumen for passage of a guidewire therethrough.

23. The apparatus of claim 21 further comprising a second elongated catheter shaft positioned coaxially around said first elongated catheter shaft.

24. The apparatus of claim 23 wherein said second elongated catheter shaft includes an internal lumen for aspiration of stenotic material removed from within the stent.

25. The apparatus of claim 1 further comprising a stenotic material collection mechanism for collecting stenotic material removed from within the stent.

26. The apparatus of claim 25 wherein said stenotic material collection mechanism comprises an embolic filter positioned in operative association with said stenotic material removal mechanism.

27. The apparatus of claim 26 wherein said embolic filter is positioned coaxially with said stenotic material removal mechanism.

28. The apparatus of claim 25 wherein said stenotic material collection mechanism is positioned internally to said stenotic material removal mechanism.

29. An apparatus for removing stenotic material from within a stent located within a body vessel, said apparatus comprising:

a catheter shaft having a proximal end and a distal end, a stenotic material removal mechanism, and

means coupled to the stenotic material removal mechanism for increasing a depth to which the stenotic material removal mechanism removes the stenotic material from within the stent, wherein said means is limited to prevent further increase in depth when or before the stenotic material removal mechanism engages the stent.

30. The apparatus of claim 29 wherein said means deactivates said stenotic material removal mechanism when or before the stenotic material removal mechanism engages the stent.

31. The apparatus of claim 29 wherein said means includes a sensor for sensing contact between said stenotic material removal mechanism and the stent.

32. The apparatus of claim 29 wherein said means includes a sensor for sensing proximity between said stenotic material removal mechanism and the stent.

33. The apparatus of claim 29 wherein said means includes sensor means for sensing contact and proximity between said stenotic material removal mechanism and the stent.

34. The apparatus of claim 29 wherein said means includes a mechanism for diametrically expanding said stenotic material removal mechanism.

35. The apparatus of claim 29 further comprising a means for directing said stenotic material removal mechanism to remove stenotic material from a selected area within the stent.

36. The apparatus of claim 29 wherein said stenotic material removal mechanism comprises at least one longitudinally oriented blade.

37. The apparatus of claim 29 wherein said stenotic material removal mechanism comprises a plurality of longitudinally oriented blades.

38. The apparatus of claim 29 wherein said stenotic material removal mechanism comprises a plurality of helically configured blades.

39. The apparatus of claim 29 wherein said stenotic material removal mechanism comprises a rotating blade.

40. The apparatus of claim 29 wherein said stenotic material removal mechanism comprises a rotating abrasive tool.

41. The apparatus of claim 29 wherein said stenotic material removal mechanism comprises a cage-like network of filaments.

42. An apparatus for removing stenotic material from within a body vessel, said apparatus comprising:

- a stenotic material removal mechanism for removing stenotic material from within the body vessel, said stenotic material removal mechanism having a plurality of elongated blades, and

- a stenotic material collection mechanism for collecting stenotic material removed from within the body vessel, said stenotic material collection mechanism including an expandable filter medium enclosed and supported by said plurality of elongated blades.

43. The apparatus of claim 42 further comprising a means for diametrically expanding said stenotic material removal mechanism.

44. The apparatus of claim 42 wherein said elongated blades are resiliently biased to expand radially outward from a central axis of said stenotic material removal mechanism.

45. A method for removing stenotic material from within a stent located within a body vessel, said method comprising:

- operating a stenotic material removal mechanism to remove stenotic material from within the stent;

- sensing proximity or contact between said stenotic material removal mechanism and the stent; and

- determining an appropriate endpoint for removal of stenotic material from within the stent based on the sensed proximity or contact between said stenotic material removal mechanism and the stent for effective recanalization of the body vessel.

46. The method of claim 45 further comprising controlling a depth to which said stenotic material removal mechanism removes the stenotic material from within the stent.

47. The method of claim 45 comprising diametrically expanding said stenotic material removal mechanism.

48. The method of claim 45 comprising directing said stenotic material removal mechanism to remove stenotic material from a selected area within the stent.

49. The method of claim 45 further comprising producing a signal indicative of the proximity or contact between said stenotic material removal mechanism and the stent.

50. The method of claim 45 further comprising deactivating said stenotic material removal mechanism when a predetermined level of proximity or contact between said stenotic material removal mechanism and the stent is detected.

51. The method of claim 45 further comprising monitoring the proximity or contact between said stenotic material removal mechanism and the stent.

52. The method of claim 51 wherein said sensor means comprises at least one electrical conductor on an exterior of said stenotic material removal mechanism and wherein the step of monitoring comprises detecting a leakage current when said at least one electrical conductor contacts the stent.

53. The method of claim 51 wherein said sensor means comprises a first electrical conductor and a second electrical conductor on an exterior of said stenotic material removal mechanism and wherein the step of monitoring comprises detecting a leakage current when said first electrical conductor and said second electrical conductor contacts the stent.

54. The method of claim 51 wherein said sensor means comprises at least one electrical conductor positioned on said stenotic material removal mechanism and wherein the step of monitoring comprises detecting a change in electrical impedance when said at least one electrical conductor approaches the stent.

55. The method of claim 51 wherein said sensor means comprises a first electrical conductor and a second electrical conductor positioned on said stenotic material removal mechanism and wherein the step of monitoring comprises detecting a change in electrical impedance when said first electrical conductor and said second electrical conductor approach the stent.

56. The method of claim 45 further comprising aspirating stenotic material removed from within the stent.

57. The method of claim 45 further comprising collecting stenotic material removed from within the stent.

58. The method of claim 45 further comprising inserting said stenotic material removal mechanism into the body vessel on an elongated catheter.

59. The method of claim 58 further comprising introducing said stenotic material removal mechanism on said elongated catheter into the body vessel through a percutaneous puncture.

60. A method for removing stenotic material from within a stent located within a body vessel, said method comprising:

- engaging a stenotic material removal mechanism to remove a portion of stenotic material from within the stent;

- expanding the stenotic material removal mechanism to remove additional portions of the stenotic material; and

- limiting the expansion of the stenotic material removal mechanism when or before the stenotic material removal mechanism engages the stent.

61. The method of claim 60 comprising diametrically expanding said stenotic material removal mechanism.

62. The method of claim 60 further comprising deactivating said stenotic material removal mechanism when or before the stenotic material removal mechanism engages the stent.

63. The method of claim 60 further comprising directing said stenotic material removal mechanism to remove stenotic material from a selected area within the stent.

64. The method of claim 60 further comprising sensing proximity or contact between said stenotic material removal mechanism and the stent.

65. The method of claim 64 further comprising deactivating said stenotic material removal mechanism when a predetermined level of proximity or contact between said stenotic material removal mechanism and the stent is detected.

66. The method of claim 60 further comprising aspirating stenotic material removed from within the stent.

67. The method of claim 60 further comprising collecting stenotic material removed from within the stent.

68. The method of claim 60 further comprising inserting said stenotic material removal mechanism into the body vessel on an elongated catheter.

69. The method of claim 68 further comprising introducing said stenotic material removal mechanism on said elongated catheter into the body vessel through a percutaneous puncture.

70. A catheter kit comprising:

(a) a catheter including:

a catheter shaft having a proximal end and a distal end, a stenotic material removal mechanism, wherein said removal mechanism is expandable, and

(b) instructions for use setting forth the following steps:

percutaneously introducing the stenotic material removal mechanism into a restenosed stent in a blood vessel;

engaging the stenotic material removal mechanism to remove a portion of stenotic material from within the restenosed stent;

expanding the stenotic material removal mechanism to remove additional portions of the stenotic material; and

limiting the expansion of the stenotic material removal mechanism when or before the stenotic material removal mechanism engages the stent; and

(c) a package holding the catheter and the instructions for use.

* * * * *