



- (51) International Patent Classification: *A47L 13/256* (2006.01)
- (21) International Application Number: PCT/US2016/054373
- (22) International Filing Date: 29 September 2016 (29.09.2016)
- (25) Filing Language: English
- (26) Publication Language: English
- (30) Priority Data: 14/873,409 2 October 2015 (02.10.2015) US
- (71) Applicant: **THE PROCTER & GAMBLE COMPANY** [US/US]; One Procter & Gamble Plaza, Cincinnati, Ohio 45202 (US).
- (72) Inventors: **TOLLENS, Fernando, Ray**; One Procter & Gamble Plaza, Cincinnati, Ohio 45202 (US). **HOYING, David, John**; One Procter & Gamble Plaza, Cincinnati, Ohio 45202 (US). **FLOOD, Janine, Anne**; One Procter & Gamble Plaza, Cincinnati, Ohio 45202 (US). **KEITH, Brian, Lee**; One Procter & Gamble Plaza, Cincinnati, Ohio 45202 (US). **ELLIS, Jessica, Lea**; 135 Pearl Street #3, Cambridge, Massachusetts 02139 (US).
- (74) Agent: **KREBS, Jay A.**; c/o THE PROCTER & GAMBLE COMPANY, Global IP Services, One Procter & Gamble Plaza, C9, Cincinnati, Ohio 45202 (US).
- (81) Designated States (unless otherwise indicated, for every kind of national protection available): AE, AG, AL, AM, AO, AT, AU, AZ, BA, BB, BG, BH, BN, BR, BW, BY, BZ, CA, CH, CL, CN, CO, CR, CU, CZ, DE, DJ, DK, DM, DO, DZ, EC, EE, EG, ES, FI, GB, GD, GE, GH, GM, GT, HN, HR, HU, ID, IL, IN, IR, IS, JP, KE, KG, KN, KP, KR, KW, KZ, LA, LC, LK, LR, LS, LU, LY, MA, MD, ME, MG, MK, MN, MW, MX, MY, MZ, NA, NG, NI, NO, NZ, OM, PA, PE, PG, PH, PL, PT, QA, RO, RS, RU, RW, SA, SC, SD, SE, SG, SK, SL, SM, ST, SV, SY, TH, TJ, TM, TN, TR, TT, TZ, UA, UG, US, UZ, VC, VN, ZA, ZM, ZW.
- (84) Designated States (unless otherwise indicated, for every kind of regional protection available): ARIPO (BW, GH, GM, KE, LR, LS, MW, MZ, NA, RW, SD, SL, ST, SZ, TZ, UG, ZM, ZW), Eurasian (AM, AZ, BY, KG, KZ, RU, TJ, TM), European (AL, AT, BE, BG, CH, CY, CZ, DE, DK, EE, ES, FI, FR, GB, GR, HR, HU, IE, IS, IT, LT, LU, LV, MC, MK, MT, NL, NO, PL, PT, RO, RS, SE, SI, SK, SM, TR), OAPI (BF, BJ, CF, CG, CI, CM, GA, GN, GQ, GW, KM, ML, MR, NE, SN, TD, TG).

[Continued on next page]

(54) Title: CLEANING PAD HAVING PREFERRED PERFORMANCE WITH WATER

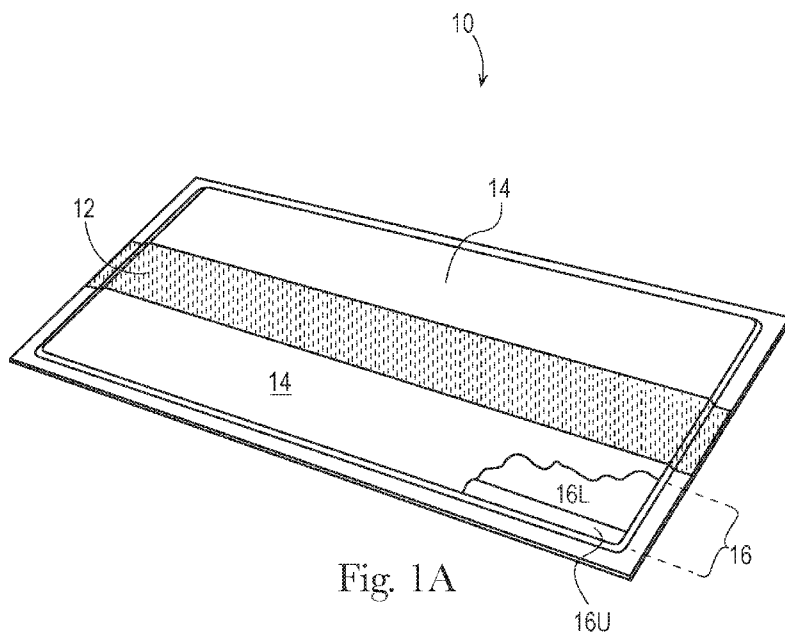

Fig. 1A

(57) Abstract: A cleaning pad for absorbing liquids from a hard, target surface. The cleaning pad has a hydrophobic floor sheet, and a core joined to the floor sheet. The core has absorbent gelling material therein with a gradient distribution, so that the pad has a particular minimum absorbency as used with water or with common amine oxide cleaning solution. A hydrophilic smoothing strip is joined to the outwardly facing surface of said floor sheet. The cleaning pad provides both good absorbency and a coefficient of friction falling within a specified range judged advantageous for cleaning. The absorbency and coefficient of friction work well with both water and an amine oxide cleaning solution.



**Published:**

— with international search report (Art. 21(3))

— before the expiration of the time limit for amending the claims and to be republished in the event of receipt of amendments (Rule 48.2(h))

## CLEANING PAD HAVING PREFERRED PERFORMANCE WITH WATER

## FIELD OF THE INVENTION

5 The present invention relates to a cleaning pad and more particularly to a cleaning pad suitable for absorbing liquid from a hard surface.

## BACKGROUND OF THE INVENTION

Attempts have been made in the art to provide cleaning pads which absorb liquids, such as  
10 cleaning solutions. The liquids may be absorbed from hard surfaces, such as floors, tables and  
countertops. Relevant attempts in the art include US 2003/0300991, 2004/0074520,  
2011/0041274, 6003191, 6048123, 6245413, 6601261, 6681434, 6701567, 6996871, 7037569,  
7096531, 7163349, 7480956, 7458128, 7624468, 8341797 and 8707505, WO200241746.

15 But hydrophobic floors, such as wood floors having aluminum oxide coatings, are difficult to  
clean. Dark color floors and shiny floors are hard to clean, particularly if consumers do not use  
enough cleaning solution. If the consumer uses too much cleaning solution, not all of it may be  
absorbed and retained by the sheet during cleaning. Improper cleaning may be caused by the  
coefficient of friction between the cleaning pad and surface being too low, and gliding over  
20 debris or being too great, and making cleaning difficult to manually accomplish. Some prior art  
attempts looked at individual materials and individual components of the cleaning pad, but did  
not consider how all of these work together to affect cleaning performance. The present  
invention overcomes these problems.

## 25 SUMMARY OF THE INVENTION

In one embodiment the cleaning pad comprises a pad having a floor sheet, and a core joined to  
the floor sheet. The core has absorbent gelling material (AGM) therein, so that the pad has a  
particular minimum absorbency as used with water or with common cleaning solutions. In a  
related embodiment, the cleaning pad may have a coefficient of friction falling within a specified  
range judged advantageous for cleaning.

In one embodiment the cleaning pad comprises a hydrophobic floor sheet having an inwardly  
facing surface and an outwardly facing surface opposed thereto. An absorbent core is joined to

the inwardly facing surface of the floor sheet. A hydrophilic smoothing strip is joined to the outwardly facing surface of said floor sheet.

#### BRIEF DESCRIPTION OF THE DRAWINGS

Fig. 1A to a top perspective view an exemplary cleaning pad according to the present invention shown partially in cutaway.

Fig. 1B is a bottom plan view of the cleaning pad of Fig. 1A, shown partially in cutaway and having one attachment strip truncated for clarity.

Fig. 2 is a schematic, vertical sectional view taken along lines 2 – 2 of Fig. 1B.

Figs. 3A – 3D are graphical representations of the generally proportionate relationship between coefficient of friction with water and absorbency of water.

Figs. 4A – 4F are graphical representations of the generally proportionate relationship between coefficient of friction with a representative amine oxide cleaning solution and absorbency of the amine oxide cleaning solution.

Fig. 5 is a schematic representation of the floor and stroke pattern used for the absorbency test.

Fig. 6 is a perspective view of a cleaning implement usable with the cleaning pad of the present invention and showing the cleaning pad in position to be removably attached to the cleaning implement.

#### DETAILED DESCRIPTION OF THE INVENTION

Referring to Figs. 1A, 1B and 2, the cleaning pad (10) of the present invention may comprise plural layers, to provide for absorption and storage of cleaning fluid and other liquids deposited on the target surface. The target surface will be described herein as a floor, although one of skill will recognize the invention is not so limited. The target surface can be any hard surface, such as a table or countertop, from which it is desired to absorb and retain liquids such as spill, cleaning solutions, etc.

The cleaning pad (10) may comprise a liquid pervious floor sheet (14) which contacts the floor during cleaning and preferably provides a desired coefficient of friction during cleaning. An absorbent core (16), preferably comprising AGM (16A) is disposed on, and optionally joined to an inwardly facing surface of the floor sheet (14). A smoothing strip (12) may be disposed on the outwardly facing surface of the floor sheet (14). Optionally, a back sheet (18) may be joined to the core (16) opposite the floor sheet (14), to provide for attachment of the cleaning pad (10) to an implement (30). The back sheet (18) may have an outwardly facing surface with one or

more attachment strips (20) to particularly facilitate attachment to an implement (30). The cleaning pad (10) may be generally planar and define an XY plane and associated X, Y axes. The Z axis is perpendicular thereto and generally vertical when the cleaning pad (10) is in use on a floor.

5

If desired, the core (16) may comprise AGM (16A) to increase the absorbent capacity of the cleaning pad (10). The AGM (16A) may be in the form of particles may be distributed within the cleaning pad (10) in such a manner to avoid rapid absorbency and absorb fluids slowly, to provide for the most effective use of the cleaning pad (10). The AGM (16A) also entraps dirty  
10 liquid absorbed from the floor, preventing redeposition. If desired foam absorbent material or fibrous material may be incorporated into the core (16).

Examining the cleaning pad (10) in more detail, the cleaning pad (10) may comprise plural layers disposed in a laminate. The lowest, or downwardly facing outer layer, may comprise apertures to  
15 allow for transmission of liquid therethrough and to promote the scrubbing of the target surface. One, two or more core (16) layers may provide for storage of the liquids, and may comprise the absorbent gelling materials. The cleaning pad (10) may have an absorbent capacity of at least 10, 15, or 20 grams of cleaning solution per gram of dry cleaning pad (10), as set forth in commonly assigned US Patent 6,003,191 and 6,601,261.

20

The optional top, or upwardly facing layer, is a back sheet (18), and may be liquid impervious in order to minimize loss of absorbed fluids and to protect the user's hand if the cleaning pad (10) is used without an implement (30). The top layer may further provide for releasable attachment of the cleaning pad (10) to a cleaning implement (30). The top layer may be made of a polyolefinic  
25 film, such as LDPE. A suitable back sheet (18) comprises a PE/PP film having a basis weight of 10 to 30 gsm.

Attached to the back sheet (18) may be one or more optional attachment strips (20). The attachment strips (20) may comprise adhesive, preferably pressure sensitive adhesive, or may  
30 loops for removable attachment to complementary hooks on an implement (30). Suitable loop attachment strips (20) may comprise a laminate of PE film and Nylon loops.

The back sheet (18) and floor sheet (14) may be peripherally joined, as is known in the art. This arrangement creates a pocket for securely holding the core (16). The core (16) may be

juxtaposed with, and optionally joined to the respective inwardly facing surfaces of the floor sheet (14) and back sheet (18).

The core (16) may comprise a single layer or two or more layers. If plural layers are selected for the core (16), the width of the layers may decrease as the floor sheet (14) is approached, as shown. The core (16) may comprise airlaid cellulose and optionally polymer fiber, as available from Glatfelter of York, PA. If two airlaid cellulose core (16) layers are selected, each layer of the core (16) may have a basis weight of at least about 75, 100, 125, 150, 175, 200, or 225 gsm and less than about 300 gsm.

Preferably each layer of the core (16) comprises AGM (16A). The AGM (16A) may absorb at least 10, 15 or 20 times its own weight. The AGM (16A) may be blown into the airlaid core (16) layer during manufacture as is known in the art. Suitable AGM (16A) is available as Z3070G from Evonik of Essen, Germany. Airlaid material containing a gradient AGM (16A) distribution is available from Glatfelter of York, PA.

The gradient distribution AGM (16A) may be achieved by using more than one forming head. For example, an airfelt/AGM (16A) line may have three forming heads. The first head may distribute a relatively large amount of AGM (16A) relative to the cellulose distributed from that head. The second forming head may distribute a less amount of AGM (16A) relative to the cellulose base, with this mixture being laid onto top of the first AGM (16A)/cellulose base. This pattern may be repeated using as many forming heads as desired. If desired the final forming head may distribute pure cellulose and no AGM (16A). Generally the layer from each forming head does not intermix with adjacent layers. Adhesive bonding and/or thermal bonding may hold superposed layers in place and provide structural rigidity.

Suitable core (16) layers and a suitable apparatus and process for making one or more layers of a core (16) having a gradient AGM (16A) distribution are found in US 8603622 issued Dec. 10, 2013. The teachings of 8603622 are incorporated herein by reference at column 5, lines 8 – 14 for the teaching of a suitable core (16) layer and at Figs. 5 – 6, with the accompanying discussion at column 16, line 41 to column 17, line 59 for the teaching of production devices suitable to make a core (16) layer for the present invention.

If two airlaid cellulose core (16) layers are selected, the lower core layer (16L), juxtaposed with the floor sheet (14), may comprise about 10 to 20 weight percent AGM (16A), with about 15 percent being found suitable. The upper core layer (16U), juxtaposed with the optional back sheet (18), if any, may comprise about 20 to about 30 weight percent AGM (16A), with about 25 percent being found suitable. The total core (16), with all layers thereof considered, may comprise 5 to 50 w%, or 10 to 45 w% AGM (16A), the amount and gradient distribution of AGM (16A) being found helpful for the present invention. The percentage of AGM (16A), as described and claimed herein refers to the weight percentage of AGM (16A) in that particular core (16) layer (16U or 16L), without regard to the floor sheet (14), back sheet (18), smoothing strip (12) or attachment strips (20).

Each core layer (16L, 16U) and particularly the upper core layer (16U) may be further stratified to provide greater absorbency benefit. The upper core layer (16U) may have three strata, as formed. The strata may comprise 0, 25, and 50 weight percent, monotonically increasing as the back sheet (18), if any, is approached, to provide a gradient distribution.

Generally it is desired that the upper core layer (16U) comprise more AGM (16A), on both an absolute basis and a weight percentage basis than the lower core layer (16L). The arrangement provides the benefit that gel blocking in the lower core layer (16L) does not prevent full absorption of liquid from the target surface and that liquids are transported upwardly and away from the floor sheet (14).

Any arrangement that provides more AGM (16A), preferably on an absolute basis or optionally on a weight percentage basis is suitable. Alternatively, either core (16) layer or a single core (16) layer may have increasing AGM (16A) concentration in the Z direction.

Any such process, as is known in the art, or arrangement, which provides for increasing AGM (16A) in the Z direction as the back sheet (18) is approached is herein considered an AGM (16A) gradient. It is to be recognized that the AGM (16A) gradient may be smooth, comprise one or more stepwise increments or any combination thereof.

The floor sheet (14) may comprise a discrete apertured nonwoven having a basis weight of about 20 to about 80 gsm and particularly about 28 to 60 gsm. The floor sheet (14) may be hydrophobic and made of synthetic fibers. A suitable floor sheet (14) is a 60 gsm PE/PP discrete

apertured spunbond nonwoven available as SofSpan from Fitsea of Simpsonville, SC. The floor sheet (14) may have a contact angle of 101 to 180 degrees with water.

5 The floor sheet (14) may comprise a smoothing strip (12). The smoothing strip (12) may have a width less than the floor sheet (14) and may comprise at least about 10, 20, 30, 40, 50, 60 or 70% of the floor sheet (14) width. The smoothing strip (12) may have a width of at least 10, 20, 30, 40, 50, 100, 150, 200, 250, mm and less than 70, 80, 100, 200 or 300 mm, with a width of 24 to 44 mm being suitable and a width of 34 mm being preferred.

10 The smoothing strip (12) may be hydrophilic. As used herein hydrophilic means having a contact angle of 0 to 100 degrees, as measured by the test method set forth herein. The smoothing strip (12) may particularly have a contact angle of 30 to 100 degrees and more particularly 55 to 90 degrees. The smoothing strip (12) may comprise at least 50% cellulosic content to be hydrophilic.

15

More particularly, a suitable smoothing strip (12) may comprise a laminate of cellulose fibers and synthetic fibers. Such a laminate is believed to be helpful in attaining the performance of the cleaning pads (10) described herein. The cellulose fiber lamina may be outwardly facing, to provide friction and absorbency on the floor. The synthetic fiber layer may be positioned on  
20 contacting relationship with the floor sheet (14) to provide integrity during use.

A 23 gsm tissue and 17 gsm polypropylene spunbond hydroentagled, sold as 40 gsm Genesis tissue by Suominen of Helsinki, Finland has been found to be a suitable smoothing strip (12). Another suitable smoothing strip (12) may comprise 28 gsm tissue and 17 gsm polypropylene  
25 spunbond hydroentagled, sold as 45 gsm Hydratexture tissue by Suominen.

Cleaning pads (10) made with these smoothing strips (12) are respectively referred to as Genesis and Hydra [for Hydratexture] in all of Figs. 3 and 4. The smoothing strips (12) were all disposed on the respective floor sheets (14) with the tissue facing outwardly and polypropylene disposed  
30 directly on the floor sheet (14).

The smoothing strip (12) may have a surface texture less than 0.5 mm, 0.4 mm or less than 0.3 mm and even be essentially 0 mm. Surface texture is measured as the peak to valley distance, independent of the smoothing strip (12) thickness. A surface texture of less than 0.5 mm is



believed to minimize streaking during cleaning, particularly when the floor dries and more particularly when a dark floor dries.

If desired, the smoothing strip (12) may have a color which contrasts with that of the floor sheet (14). This arrangement provides the benefit of a signal to the consumer that the smoothing strip (12) and floor sheet (14) have different functionalities.

Referring to all of Figs. 3A – 4F, inclusive, representative cleaning pads (10) are tested for both absorbency and kinetic coefficient of friction, using the respective test methods described herein. Commercially available cleaning pads (10) include those purchased from or under the names of Dollar General, Grime Boss, Great Value, Kroger, Lola, Price First, Rite Aid, Swiffer and Target, it being understood that commercially available products may change over time.

Four cleaning pads (10) according to the present invention were also tested. Two of these cleaning pads (10) used the aforementioned 34 mm Genesis smoothing strip (12). Two of these cleaning pads (10) used the aforementioned 34 mm Hydra smoothing strip (12). All four of the cleaning pads (10) according to the present invention utilized an absorbent core (16) having two airlaid layers (16U), (16L) of cellulose and AGM (16A), a floor sheet (14) and a back sheet (18). The two cleaning pads (10) labelled ‘Grad’ used a gradient core (16). The upper core layer (16U) is the core layer disposed closer to and juxtaposed with the back sheet (18). The lower core layer (16L) may be closer to and juxtaposed with the floor sheet (14). One of skill will recognize that juxtaposition includes contacting the adjacent component. Pads made for test purposes and not having AGM (16A) in the absorbent core (16) or a smoothing strip (12) are labelled ‘NO AGM’ and ‘No Strip,’ respectively. The specific materials used in the cleaning pads (10) representing the four data points described and claimed herein are set forth in Table 1 below.

Table 1

Component	Genesis	Hydra	Grad Genesis	Grad Hydra
Smoothing Strip (12)	Genesis – 40gsm Hydroentangled Laminate -- 23gsm Pulp/ 17gsm Spunbond	Hydratexture – 45gsm Hydroentangled Laminate -- 28gsm Pulp/ 17gsm Spunbond	Genesis – 40gsm Hydroentangled Laminate -- 23gsm Pulp/ 17gsm Spunbond	Hydratexture – 45gsm Hydroentangled Laminate -- 28gsm Pulp/ 17gsm Spunbond
Floor Sheet (14)	60gsm Spunbond PP/PE Blend – Apertured	60gsm Spunbond PP/PE Blend – Apertured	60gsm Spunbond PP/PE Blend – Apertured	60gsm Spunbond PP/PE Blend – Apertured
Lower Core Layer (16L)	150gsm Airlaid – 15% AGM, 29% PE/PET fiber, 56% pulp	150gsm Airlaid – 15% AGM, 29% PE/PET fiber, 56% pulp	150gsm Airlaid – 15% AGM, 29% PE/PET fiber, 56% pulp	150gsm Airlaid – 15% AGM, 29% PE/PET fiber, 56% pulp
Upper Core Layer (16U)	150gsm Airlaid – 25% AGM, 12% PE/PET fiber, 63% pulp	150gsm Airlaid – 25% AGM, 12% PE/PET fiber, 63% pulp	310gsm Gradient Airlaid Gradient Core per Table 2	310gsm Gradient Airlaid Gradient Core per Table 2
Back Sheet (18)	21 gsm PP/PE Film	21 gsm PP/PE Film	21 gsm PP/PE Film	21 gsm PP/PE Film

The particular core (16) construction provides for a compound gradient distribution of AGM (16A) within the core. The upper core layer (16U) has 35 w% AGM. The lower core layer (16L) has 15 w% AGM. A core (16) having two, or more core layers (16U), (16L) disposed in contacting relationship may have an AGM (16A) gradient distribution which increases, as the floor sheet (14) is approached and decreases, as the back sheet (18) is approached. The AGM (16A) gradient may be monotonic or non-monotonic.

The upper core layer (16U) and/or lower core layer (16L) may have an AGM (16A) gradient distribution therein. Again, it is desired that the AGM (16A) distribution increase/decrease as set forth above within the core layer (16L)(16U).

The upper core layer (16U) of the two cleaning pads (10) according to the present invention and labelled 'Grad' described above has the AGM (16A) distribution set forth in Table 2 below. Particularly the upper core layer (16U) comprises three strata within that particular layer (16U). The strata provide for a gradient AGM (16A) distribution within that layer (16U) and a compound AGM (16A) within the core (16).

Table 2

Strata	w%
<b>Strata Towards Floor Sheet (14) and Lower Core Layer (16L)</b>	
(Latex Glue)	0.8
(Pulp)	13.2
(Bico Fiber)	4.4
<b>Middle Strata</b>	
(Pulp)	20.6
(AGM)	13.9
<b>Strata Towards Back Sheet (18)</b>	
(Pulp)	20.6
(AGM)	20.9
(Pulp)	5.5

In contrast, a commercially available Swiffer WetJet cleaning pad has an upper core layer (16U) and lower core layer (16L) with 15 w% and 25 w% AGM, respectively for a total of 20.5 w% AGM in the core (16). This commercially available cleaning pad has coefficients of friction of 0.6 with water and 0.5 with amine oxide cleaning solution.

If a gradient distribution within a core layer (16L)(16U) occurs, that respective layer is considered as a whole when determining whether the overall core (16) has a gradient AGM (16A) distribution. Thus, the embodiment described and claimed herein has a gradient core (16) due to the AGM (16A) distribution of 15% in the lower core layer (16L) and 35 w% in the upper core layer (16U). An AGM distribution of at least 15 w%, and preferably 20 w%, 25 w%, 30 w% or 40w% is desired between the lower upper core layer (16U) and lower core layer (16L).

Referring to Fig 3A, the inventors have recognized that, under testing with deionized water, cleaning pads (10) exhibit a generally positive correlation between coefficient of friction and absorbency. Conceptually two relatively straight lines may be drawn, one from WetJet Extra Power to Grad Hydra and one from Great Value to No AGM + Hydra. Such correlation is unexpected in view of the prior art.

20

Referring to Fig. 3B, it can be seen that under testing with deionized water, cleaning pads (10) according to the present invention may have an absorbency of at least 0.45, preferably at least

0.48, more preferably at least 0.5, more preferably at least 0.55, more preferably at least 0.6, more preferably at least 0.65, but less than 1.0, 0.9 or 0.8. An absorbency with water in this range is judged advantageous for cleaning purposes, without requiring undue AGM (16A) levels and the associated costs and material handling challenges.

5

Referring to Fig 3C, it can be seen that under testing with deionized water, cleaning pads (10) according to the present invention may have coefficient of friction of at least 0.6 [current WetJet having a coefficient of friction of 0.6 with water], preferably at least 0.65, more preferably at least 0.7, but less than 0.9, and preferably less than 0.8. A coefficient of friction with water in this range is judged advantageous for cleaning purposes, without requiring undue cleaning effort at greater friction levels or without skipping over dirt and not adequately cleaning the floor at lower friction levels.

10

Referring to Fig 3D, it can be seen that under testing with deionized water, particularly desirable cleaning pads (10) according to the present invention may have a coefficient of friction of at least 0.4, more preferably at least 0.5, more preferably at least 0.6, more preferably at least 0.65, more preferably at least 0.7, but less than 0.9 or less than 0.8 and may further have an absorbency of at least 0.45, preferably at least 0.48, more preferably at least 0.5, more preferably at least 0.55, more preferably at least 0.6, more preferably at least 0.65, but less than 1.0, 0.9 or 0.8. The performance of such a cleaning pad (10) is represented by the shaded box of Fig. 3D.

15

To further investigate the performance of a cleaning pad (10) according to the present invention, the cleaning pads (10) were tested with an amine oxide cleaning solution, as described herein. It is believed that testing with this amine oxide cleaning solution more accurately represents the cleaning performance of a cleaning pad (10) in use.

20

Referring to Fig. 4A, the inventors have recognized that, under testing with amine oxide cleaning solution, cleaning pads (10) exhibit a generally positive correlation between coefficient of friction and absorbency. Conceptually three relatively straight lines may be drawn, one from WetJet Extra Power to Grad Genesis, one from Target II (2) to Rite Aid, and one from Target I to Dollar General. All three lines have a generally similar slope and linear correlation. Such correlation is unexpected in view of the prior art.

25

30

Referring to Fig. 4B, it can be seen that under testing with amine oxide cleaning solution, cleaning pads (10) according to the present invention may have an absorbency with amine oxide cleaning solution of at least 0.35, preferably at least 0.4, more preferably at least 0.45, more preferably at least 0.5, more preferably at least 0.55, but less than 0.9, 0.85 or 0.8. An  
5 absorbency with amine oxide cleaning solution in this range is judged advantageous for cleaning purposes, without requiring undue AGM (16A) levels and the associated costs and material handling challenges.

Referring to Fig 4C, it can be seen that under testing with amine oxide cleaning solution, cleaning pads (10) according to the present invention may have a coefficient of friction of at least  
10 0.5, preferably at least 0.55, more preferably at least 0.6, more preferably at least 0.65, but less than 0.9, and more preferably less than 0.8 and more preferably less than 0.75. A coefficient of friction with amine oxide cleaning solution in this range is judged advantageous for cleaning purposes, without requiring undue cleaning effort at greater friction levels or without skipping  
15 over dirt and not adequately cleaning the floor at lower friction levels.

Referring to Fig. 4D, it can be seen that under testing with amine oxide cleaning solution, cleaning pads (10) according to the present invention may have an absorbency conforming to the inequality:

$$\text{Absorbency} > 0.7 * \text{cof} - 0.14,$$

wherein  $0.5 < \text{cof} < 0.85$  and

absorbency  $< 1$ ,

and cof is the coefficient of friction.

Optionally  $0.55 < \text{cof} < 0.8$ , or  $0.6 < \text{cof} < 0.75$ .

absorbency  $< 0.9$  or  $< 0.8$  and the 0.7 multiplier of the coefficient of friction may be 0.75 - 0.8.

Such inequality is unexpected in view of the prior art.

A cleaning pad (10) that conforms to this inequality is judged advantageous for cleaning purposes, without requiring undue AGM (16A) levels and the associated costs and material handling challenges and judged advantageous without requiring undue cleaning effort at greater

friction levels or without skipping over dirt and not adequately cleaning the floor at lower friction levels, wherein:  $0.5 < \text{cof} < 0.9$ , and/or  $0.35 < \text{absorbency} < 0.60$ .

An absorbency with amine oxide cleaning solution in this range is judged advantageous for cleaning purposes, without requiring undue AGM (16A) levels and the associated costs and material handling challenges.

- 5 Referring to Fig. 4E, the unpredicted linear relationship of four cleaning pad (10)s according to the present invention is illustrated. But utilizing this previously unknown relationship it is believed an improved cleaning pad (10) is provided.

- 10 Referring to Fig. 4F, a cleaning pad (10) according to the present invention may conform to the region of the graph illustrated between the upper and lower lines. Such a cleaning pad (10) may conform to the equation  $\text{Absorbency} = 0.7 * \text{cof} + /- 0.1$ .

wherein  $0.5 < \text{cof} < 0.9$  and  
absorbency  $< 1$ ,

and cof is the coefficient of friction.

Optionally  $0.55 < \text{cof} < 0.75$ , absorbency  $< 0.9$  or  $< 0.8$  and the band about the line can be  $+ / - 0.05$ . Such equation is unexpected in view of the prior art.

#### Test Methods

- 15 Prior to any testing, each cleaning pad (10) is conditioned for at least 24 hours in a controlled room at 20 - 25 degrees C and 40 – 50 % relative humidity.

#### Surface Texture

- 20 The texture outwardly facing surface of the smoothing strip (12) is measured while the smoothing strip (12) is still attached to the balance of the cleaning pad (10). The cleaning pad (10) is cut, parallel to the width dimension of the cleaning pad (10) using a sharp knife in a manner that is not injurious to the texture of the floor sheet (14) or smoothing strip (12). The sample is viewed from the edge, so that a cross sectional view of the cut plane can be measured.

The surface texture topography of the smoothing strip (12) is determined to the nearest 0.01 mm, by measuring a linear distance along an axis perpendicular to the floor-facing planar surface of the smoothing strip (12). The distance to be measured is the vertical span, perpendicular to the plane of the smoothing strip (12), between the bottom of a valley and the top of an adjacent peak, wherein both endpoints are located on the floor-facing surface of the smoothing strip (12).  
5 Distances are measured using the Point to Point measurement function or equivalent.

This procedure is repeated for a total of  $n = 1$  measurements on each of five different cleaning pads (10). The five results are averaged to determine the surface texture for the smoothing strip  
10 (12).

A suitable digital microscope for making the measurements is a Nikon SMZ1500 with the Nikon TV Lens C-0.6x, having an Infinity 2 Camera from Lumenera Corporation of Ottawa, Canada. Suitable measurement software includes INFINITY ANALYZE, Release 5.0.3 from Lumenera Corporation.

15

#### AGM Gradient

Prophetically Micro X-ray Computed Tomography [CT] may be used to determine if the core (16), or a layer thereof, has a gradient AGM (16A) distribution. CT imaging reports the X-ray absorption of a sample in three-dimensions. MicroCT scanner instruments use a cone beam X-ray source to irradiate the sample. The radiation is attenuated by the sample and a scintillator converts the transmitted X-ray radiation to light and passes it into an array of detectors. X-ray attenuation is largely a function of the material density of the sample, so denser materials require a higher energy to penetrate and appear brighter (higher attenuation), while void areas appear darker (lower attenuation). Intensity differences in grey levels are used to distinguish between  
20 different structures in the sample, such as synthetic/cellulose fibers, AGM (16A) particles, voids, and non-void areas. Two-dimensional (2D) projected images can be acquired from different angles as the sample is rotated, enabling the creation of a digital three-dimensional (3D) reconstruction image of the sample using 3D imaging software. Resolution is a function of the instrument characteristics, diameter of the field of view and the number of projections used. The  
25 dataset obtained of the sample is visualized and analyzed via image processing software program(s) in order to measure 3D structures and intensities.  
30

#### Absorbency

Absorbency is measured using the following equipment.

A floor mop having a weight of 2.2 +/- 0.2 kg without the cleaning pad (10) and having a handle (34) and head (32). The head (32) is connected to the proximal end of the handle (34) by a ball and socket joint or universal joint.

- 5 Referring to Fig. 6, the head (32) is rectangular with dimensions of 11.4 cm x 27.3 cm, a 2 mm crown extending in the 27.3 cm direction and is covered with a compliant surface, such as EVA on the floor side. The handle (34) has a straight section (34S) with a length of 108 +/- 2.5 cm from the center of the ball and socket or universal joint. The straight section (34S) of the handle (34) has a grip (34G) at the distal end thereof, the grip (34G) being oriented at 45 +/- 5 degrees to  
10 the straight section (34S). The center of the grip (34G), as grasped by a typical user, is 5 +/- 2 cm from the transition between the straight section (34S) and grip (34G). A Swiffer WetJet (30) mop currently sold by the instant assignee, is suitable.

A metronome set at 70 beats per minute.

- An mahogany plank engineered hardwood floor having dimensions of 122 cm x 91 cm  
15 with an aluminum oxide polyurethane coating and contact angle of 100 +/- 15 degrees with deionized water. Each plank is 12.1 cm wide with a 1 mm gap between adjacent planks. The floor has a 60 degree gloss reading of 85 +/- 5 Gloss Units. The boards are aligned parallel to the short direction, so that each board is at least 91 cm long extending that length without a seam. A Home Legend Santos Mahogany Engineered Hardwood floor, UPC 664646301473, has been  
20 found suitable.

A tared bottle of the liquid to be tested.

A hand-held trigger sprayer which sprays approximately 1.24 grams per stroke.

A scale accurate to 0.01 grams, as available from Mettler Toledo.

1300 grams of dionized water.

- 25 1300 grams of solution comprising 0.04% amine oxide active (C10-16 Alkyldimethyl) CAS no. 70592-80-2, 0.5% EtOH ethyl alcohol and balance deionized water. This solution is hereinthroughout referred to as an amine oxide cleaning solution, and is representative of common, commercially available cleaning solutions.

80/20 dionized water/ isopropyl alcohol solution.

30

The floor is cleaned before each trial with the 80/20 water/IPA solution and dried with paper towels. A sample cleaning pad (10) is weighed to determine the initial weight using the scale.



Referring to Fig. 5, the floor may be conceptually divided into a 4 x 3 grid of 12 squares, with each square being 30.5 cm x 30.5 cm. Deionized water is sprayed onto the test surface in the respective centers of the four squares spaced as shown with the stars, so that an uneven distribution of the water occurs. Approximately 2.75 to 3 grams of water is sprayed onto each square indicated in Fig. 5 for a total of 11 to 12 grams of water on the test surface. The spray bottle is reweighed to determine the amount of liquid sprayed onto the floor.

The cleaning pad (10) is attached to the mop. If the cleaning pad (10) is larger than the head (32), the cleaning pad (10) is centered and trimmed to fit, so that an edge of the cleaning pad (10) does not fold or improperly drag during testing. If a smaller cleaning pad (10) is used, the cleaning pad (10) is centered on the head (32).

The metronome is actuated. The mop is stroked forward and backwards six strokes in each direction for a total of 12 strokes to cover the entire floor from left to right as shown in Fig. 5. The test is conducted using ordinary mopping force as applied through the mop handle (34) for the prescribed mopping rate, with no intentional compressive force added or subtracted by the user, so that the total weight on the floor remains 2.2 +/- 0.5 kg. The 12 strokes are repeated in reverse from right to left, to return to the starting point to complete one trial. The test user does not step on the test surface during any portion of the 12 strokes, but moves left to right as occurs under ordinary mopping conditions.

Mopping occurs at the rate of 70 strokes per minute, using the metronome. Each beat of the metronome matches a stroke from forward to backwards or vice versa, for 24 total beats during the strokes used to complete a single test. The cleaning pad (10) is reweighed to determine the amount of liquid absorbed during mopping. The percentage of the water absorbed by the cleaning pad (10) is determined by dividing the amount of water absorbed by the amount of water dosed onto the test floor and converted to a decimal value.

This procedure is repeated for a total of  $n = 13$  trials for each cleaning pad (10) and the results averaged, with the floor being cleaned before each new trial using the aforementioned 80/20 solution. A total of  $n = 3$  cleaning pads (10) are tested. The results of the three cleaning pads (10) are averaged to obtain the absorbency of that pad for deionized water. The absorbency is reported as a decimal, representing a fraction between and including 0 and 1.

This procedure, including the floor preparation, is repeated for the aforementioned amine oxide/ethyl alcohol solution. This solution, referred to herein as an amine oxide cleaning solution represents a common type of commercially available cleaning solution for the test purposes described and claimed herein.

5

#### Coefficient of Friction

The coefficient of friction of a material is the resistive force of friction divided by the normal or perpendicular force pushing the material against a surface. The coefficient of friction test method uses a Friction/Peel Tensile Tester, Model Insight 10 from MTS System Corporation of  
10 Eden Prairie, MN to measure the kinetic coefficient of friction.

A 203 g sled, with dimensions of 6.5 cm × 11.0 cm × 1.5 cm and having hook fasteners on the bottom surface is provided. A first sample of the cleaning pad (10) is attached to the sled using the hooks. If the cleaning is larger than the sled, the cleaning pad (10) is centered and trimmed to fit, so that an edge of the cleaning pad (10) does not fold during testing. If a smaller cleaning pad  
15 (10) is used, the cleaning pad (10) is centered on the sled. The pressure of the sled is about 2.84 g/cm<sup>2</sup>. This pressure simulates the typical pressure applied to a cleaning pad (10) by a lightweight mop while a user is cleaning a floor.

The test surface is a glass plate 15 cm wide x 28 cm long x 5 mm thick, available from MTS System Corporation as part of Friction Test apparatus, part no. 100087526. The sled and test  
20 surface are cleaned using the aforementioned 80/20 IPA/water solution. The instrument is set up as follows:

1. Set the "Sled Weight" to 203 g.
2. Set the "Data Acq. Rate" to 20 Hz.
3. Set the "Begin Point" to 10 mm.
- 25 4. Set the "End Point" to 130 mm.
5. Set the "Extension Limit High" to 135 mm.
6. Set the "Crosshead" speed to 1000 mm/min.
7. "Return" the load cell to the starting point for test.
8. Place the first sample and sled on top of the glass plate at about 5 mm from back edge of  
30 the glass test surface such that the sled is lined up at the center of the path where the hook on the sled lines up with the eyelet of the load cell.

9. Attach the sled to the load cell by passing a string through the pulley and up to the clamp on the test apparatus. Close the clamp on the string to secure it.
10. Add 0.5 ml of test solution to the glass plate using a volumetric pipette 1 cm in front of the sample. The test solution should be applied to an area of about 50 mm in width (the width being defined as the dimension perpendicular to the direction of the sled) by 20 mm in length (the length being defined as the dimension parallel to the direction of the sled in motion) The same test solution is used for both the absorbency test and the coefficient of friction test. That absorbency and coefficient of friction are either both tested with water or both tested with the amine oxide cleaning solution described herein.
11. Initiate test by pressing the “play” icon. The load cell starts moving from the back to the front dragging the sled and the test sample.
12. When the test is complete, the load cell stops and the program will display the measure of the Static Coefficient of Friction (ST) as well as the Kinetic Coefficient of Friction (KI). Record the Kinetic Coefficient of Friction measurement. Activate the “Return” button so that the sled with the sample returns to the starting position. Position the sled in the starting position. Then press the play icon in order to repeat the test.
13. Again when the test is completed, the load cell stops and the program will display the Kinetic Coefficient of friction. Record this measurement.
14. Again activate the Return button to send the sled back to the start position.
15. Repeat test by positioning the sled with test sample at back edge as previously discussed.
16. Each sample is tested three times. The test surface is not re-wetted for the second and third trials.
17. Calculate the average of these 3 measurements
18. Repeat this procedure for  $n = 3$  samples and average the results.

## 25 Static Contact Angle

The cleaning pad (10) is tested with the floor sheet (14) facing upwardly, so that the floor sheet (14) and smoothing strip (12), are exposed. The back sheet (18) is placed on a flat, horizontal surface. The area of test sample (i.e., floor sheet (14) or smoothing strip (12)) is sufficient to prevent spreading of the test drop to the edge of the sample being tested or drops from contacting each other. The sample test surface is not directly touched during preparation or testing, to avoid finger contamination.

A contact angle goniometer is used to measure the static contact angle of the floor sheet and/or smoothing strip. The method described hereinbelow is derived from ASTM D5946-09.

The apparatus for measuring contact angle has: (1) a liquid dispenser capable of suspending a sessile drop, as specified, from the tip of the dispenser, (2) a sample holder that allows a sample to lay flat without unintended wrinkles or distortions, and hold the sample so that the surface being measured is horizontal, (3) provision for bringing the sample and suspended droplet towards each other in a controlled manner to accomplish droplet transfer onto the test surface, and (4) means for capturing a profile image of the drop with minimal distortion. A 5 degree  
5  
10  
15  
lookdown angle is used, so that the line of sight is raised 5 degrees from the horizontal and the baseline of the drop is clearly visible when in contact with the sample. The apparatus has means for direct angle measurements, such as image analysis of the drop dimensions and position on the sample. A FTÅ200 dynamic contact angle video system analyzer manufactured by First Ten Angstroms, Portsmouth, VA has been found suitable. FTÅ software supplied by First Ten  
15  
Angstroms (Build 362, Version 2.1) has been found suitable. Lighting is adjusted so a clear image is resolvable by the software, to extract the baseline and droplet contour without user input.

A test sample is placed onto the specimen holder of the instrument ensuring that the sample is  
20  
lying flat without unintended wrinkles or distortions. A single droplet of 6.5 +/- 1.5 µL of deionized water is transferred by contact from a 22 gauge syringe needle dispenser onto the surface of the sample, i.e. the floor sheet (14) or smoothing strip (12), as the case may be. Images of the profile of the drop are collected by the software at a rate of at least 20 images/s. The contact angle between the droplet and the test surface is measured, in degrees, when the  
25  
sessile volume has decreased by 2% of the initial volume. If a 2% decrease in sessile volume does not occur, as for example may happen if the test sample is not absorbent, the contact angle is measured at equilibrium, as determined by lack of additional wetting and lack of movement of the droplet.

30  
The test sample is moved, in order to place the next droplet onto a clean, undisturbed area of the sample, preferably at least 25mm away from any previous measurements. The test is repeated for a total of n = 5 samples. The measurements are checked to see if the measurements vary by more than 5 degrees from the minimum reading to the maximum reading. If the results of n = 5

tests do not vary by more than 5 degrees, and the  $n = 5$  results are averaged to yield the static contact angle.

If the readings vary by more than 5 degrees, then a total of  $n = 20$  readings are taken and the  
5 results averaged. The  $n = 20$  average is then used.

#### Implement (30)

The cleaning pad (10) according to the present invention may be used by hand or with a cleaning  
10 implement (30). Referring to Fig. 6, the cleaning implement (30) may comprise a plastic head  
(32) for holding the cleaning pad (10) and an elongate handle (34) articulably connected thereto.  
The handle (34) may comprise a metal or plastic tube or solid rod.

The head (32) may have a downwardly facing surface, to which the cleaning pad (10) may be  
15 attached. The downwardly facing surface may be generally flat, or slightly convex. The head  
(32) may further have an upwardly facing surface. The upwardly facing surface may have a  
universal joint to facilitate connection of the elongate handle (34) to the head (32).

A hook and loop system may be used to attach the cleaning pad (10) directly to the bottom of the  
20 head. Alternatively, the upwardly facing surface may further comprise a mechanism, such as  
resilient grippers, for removably attaching the cleaning pad (10) to the implement (30). If  
grippers are used with the cleaning implement (30), the grippers may be made according to  
commonly assigned US patents 6,305,046; 6,484,346; 6,651,290 and/or D487,173.

25 The cleaning implement (30) may further comprise a reservoir for storage of cleaning solution.  
The reservoir may be replaced when the cleaning solution is depleted and/or refilled as desired.  
The reservoir may be disposed on the head (32) or the handle (34) of the cleaning implement  
(30). The neck of the reservoir may be offset per commonly assigned US patent 6,390,335. The  
cleaning solution contained therein may be made according to the teachings of commonly  
30 assigned US patent 6,814,088.

The cleaning implement (30) may further comprise a pump for dispensing cleaning solution from  
the reservoir onto the target surface, such as a floor. The pump may be battery powered or  
operated by line voltage. Alternatively, the cleaning solution may be dispensed by gravity flow.

The cleaning solution may be sprayed through one or more nozzles to provide for distribution of the cleaning solution onto the target surface in an efficacious pattern.

If a replaceable reservoir is utilized, the replaceable reservoir may be inverted to provide for gravity flow of the cleaning solution. Or the cleaning solution may be pumped to the dispensing  
5 nozzles. The reservoir may be a bottle, and may be made of plastic, such as a polyolefin. The cleaning implement (30) may have a sleeve (36), which removably receives the bottle, or other reservoir. The cleaning implement (30) may have a needle, optionally disposed in the sleeve (36) to receive the cleaning solution from the bottle. The bottle may have a needle piercable  
10 membrane, complementary to the needle, and which is resealed to prevent undesired dripping of the cleaning solution during insertion and removal of the replaceable reservoir. Alternatively or additionally, If desired, the implement (30) may also provide for steam to be delivered to the cleaning pad (10) and/or to the floor or other target surface.

A suitable reservoir of cleaning solution and fitment therefor may be made according to the  
15 teachings of commonly assigned US Patents 6,386,392, 7,172,099; D388,705; D484,804; D485,178. A suitable cleaning implement (30) may be made according to the teachings of commonly assigned US Patents 5,888,006; 5,960,508; 5,988,920; 6,045,622; 6,101,661; 6,142,750; 6,579,023; 6,601,261; 6,722,806; 6,766,552; D477,701 and/or D487,174. A steam  
20 implement (30) may be made according to the teachings of jointly assigned 2013/0319463.

The dimensions and values disclosed herein are not to be understood as being strictly limited to the exact numerical values recited. Instead, unless otherwise specified, each such dimension is intended to mean both the recited value and a functionally equivalent range surrounding that  
25 value. For example, a dimension disclosed as “40 mm” is intended to mean “about 40 mm” whether or not the term ‘about’ is expressly recited. Every range disclosed herein includes all endpoints of that range whether disclosed within that range or as part of a related range. Thus two endpoints of the same range may be disclosed as endpoints of broader or narrower ranges. The common mathematical symbols > and < mean greater than or equal to and less than or equal  
30 to, respectively, and include the endpoints set forth in the equations and inequalities below.

Every document cited herein, including any cross referenced or related patent or application, is hereby incorporated herein by reference in its entirety unless expressly excluded or otherwise limited. The citation of any document is not an admission that it is prior art with respect to any

invention disclosed or claimed herein or that it alone, or in any combination with any other reference or references, teaches, suggests or discloses any such invention. Further, to the extent that any meaning or definition of a term in this document conflicts with any meaning or definition of the same term in a document incorporated by reference, the meaning or definition  
5 assigned to that term in this document shall govern.

While particular embodiments of the present invention have been illustrated and described, it would be obvious to those skilled in the art that various other changes and modifications can be made without departing from the spirit and scope of the invention. It is therefore intended to  
10 cover in the appended claims all such changes and modifications that are within the scope of this invention.

## CLAIMS

What is claimed is:

1. A cleaning pad (10) comprising:  
a liquid pervious floor sheet (14), and  
an absorbent core (16) juxtaposed with said floor sheet (14) and comprising absorbent gelling material therein, characterized by said cleaning pad (10) having an absorbency with water of 0.48 to 1.
2. A cleaning pad (10) according to claim 1 characterized by having an absorbency with water of 0.5 to 1.
3. A cleaning pad (10) according to claim 2 characterized by having an absorbency with water of 0.55 to 0.9.
4. A cleaning pad (10) according to any preceding claim characterized by having a coefficient of friction with water of 0.6 to 0.9.
5. A cleaning pad (10) according to any preceding claim comprising from 5 to 50 w% AGM (16A).
6. A cleaning pad (10) according to claim 5 having a gradient distribution of AGM (16A), with AGM (16A) percentage decreasing as the floor sheet (14) is approached.
7. A cleaning pad (10) according to any preceding claim characterized by having an absorbency with amine oxide cleaning solution from 0.4 to 0.9.
8. A cleaning pad (10) comprising:  
a liquid pervious floor sheet (14), and  
an absorbent core (16) juxtaposed with said floor sheet (14) and comprising absorbent gelling material therein, said cleaning pad (10) having an absorbency with amine oxide cleaning solution from 0.35 to 1.
9. A cleaning pad (10) according to claim 7 wherein said absorbency with amine oxide cleaning solution is from 0.4 to 0.9.



10. A cleaning pad (10) according to claim 8 wherein said absorbency with amine oxide cleaning solution is from 0.4 to 0.65.
11. A cleaning pad (10) according to claims 8, 9 and 10 having a coefficient of friction with amine oxide cleaning solution from 0.5 to 0.9.
12. A cleaning pad (10) according to claims 8, 9, 10 and 11 characterized by having an absorbency with water of 0.5 to 1.
13. A cleaning pad (10) according to claims 8, 9, 10, 11 and 12 comprising from 5 to 50 w% AGM (16A).
14. A cleaning pad (10) according to claim 13 having a gradient distribution of AGM (16A), with AGM (16A) percentage decreasing as the floor sheet (14) is approached.
15. A cleaning pad (10) according to any preceding claim wherein said liquid pervious floor sheet (14) has an outwardly facing surface, and characterized by said cleaning pad (10) further comprising a hydrophilic smoothing strip (12) joined to said outwardly facing surface of said floor sheet (14).

1/14

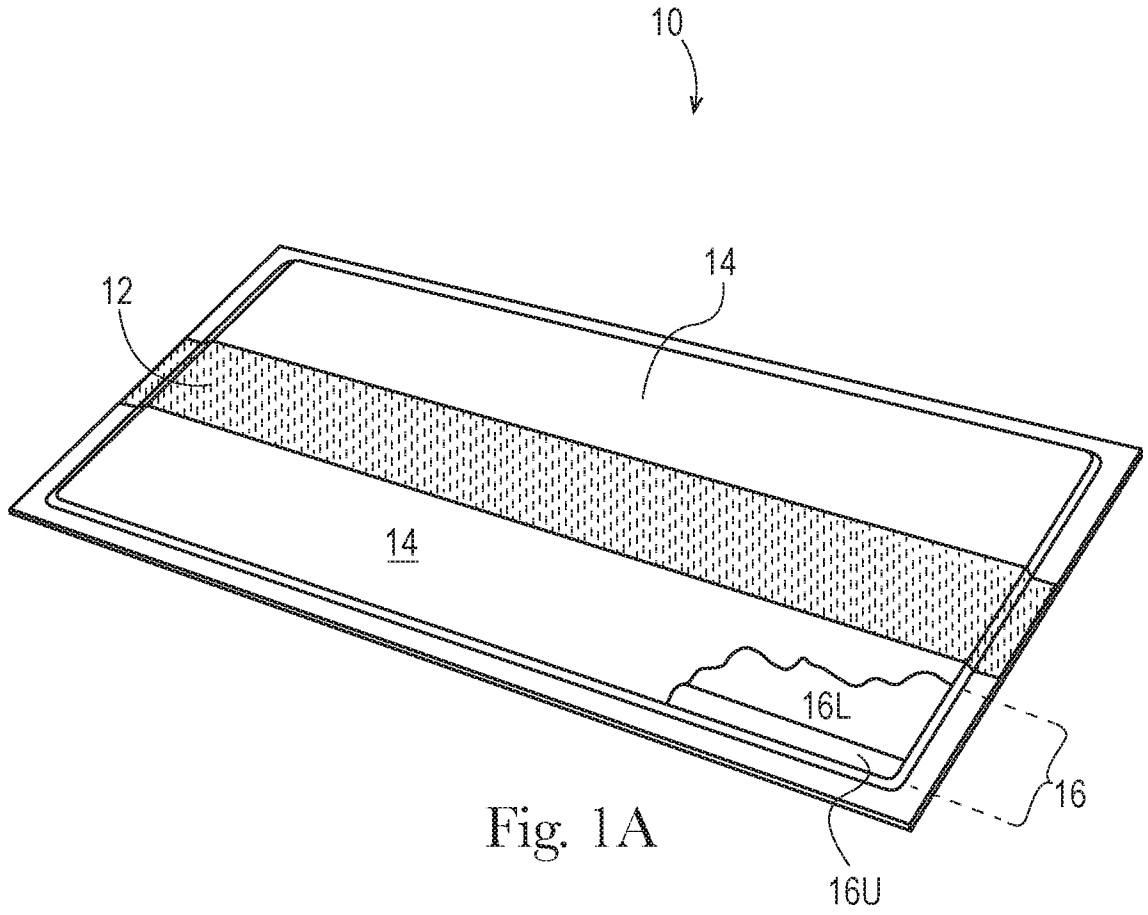

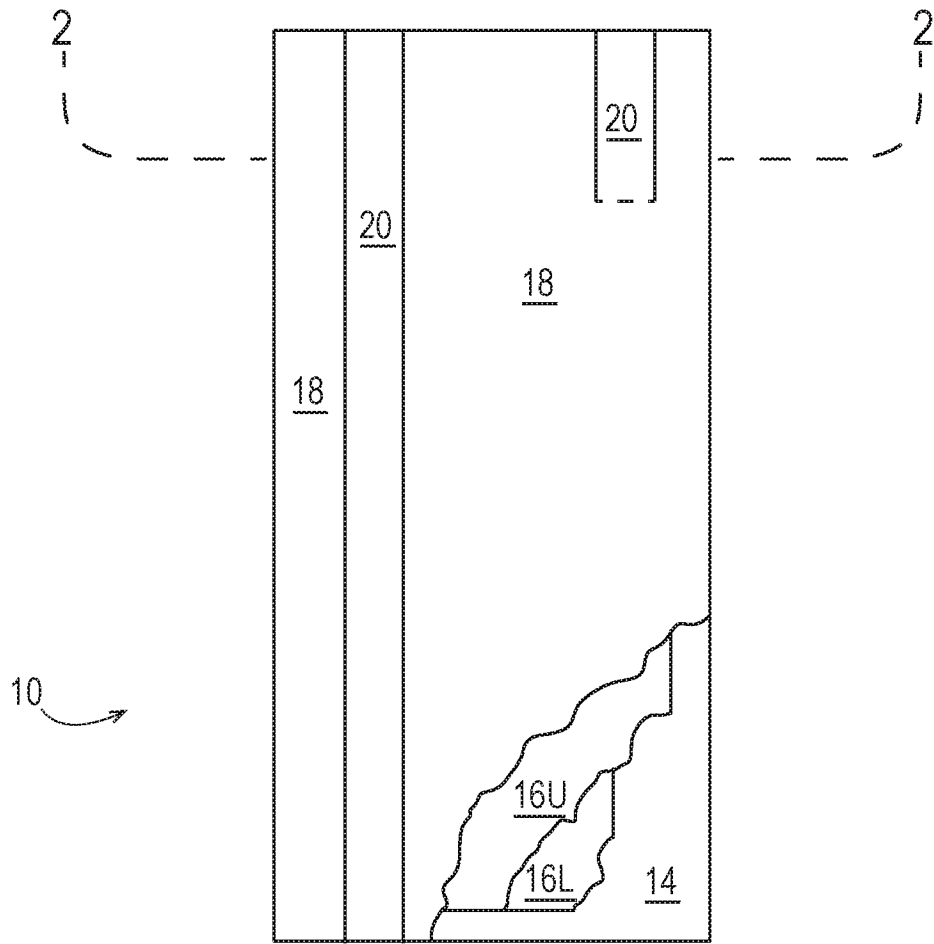

Fig. 1B

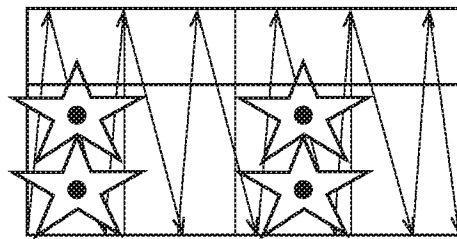
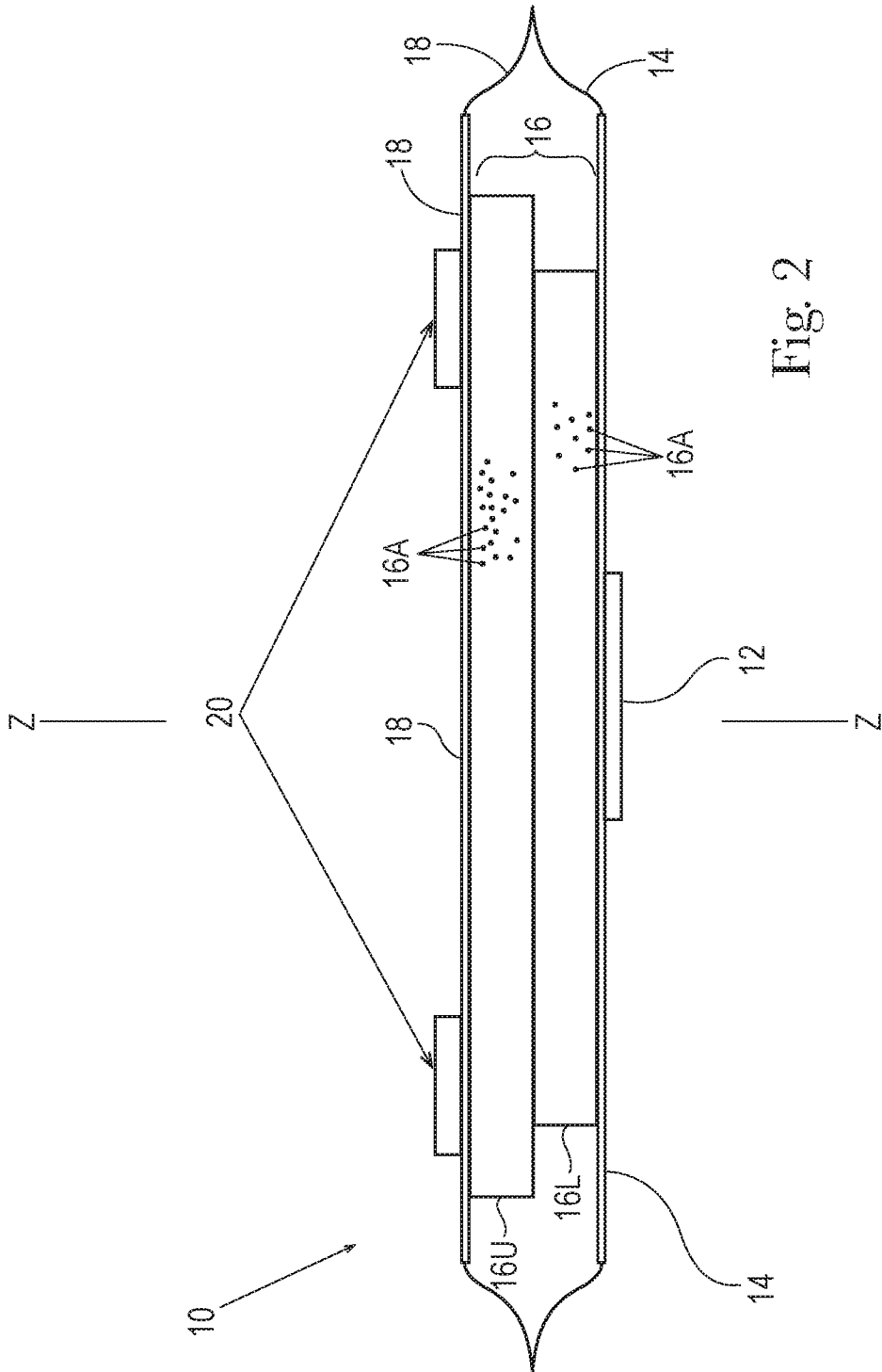

Fig. 5



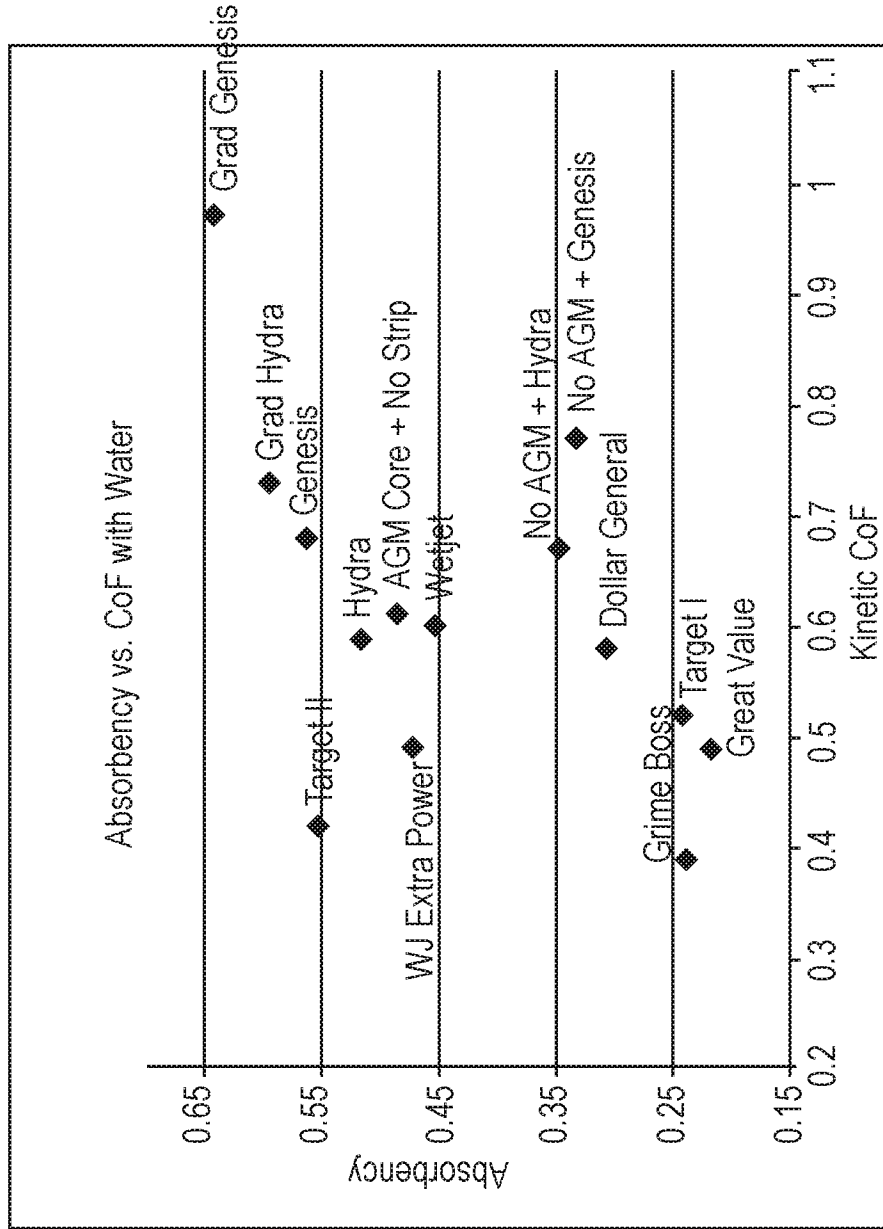

Fig. 3A

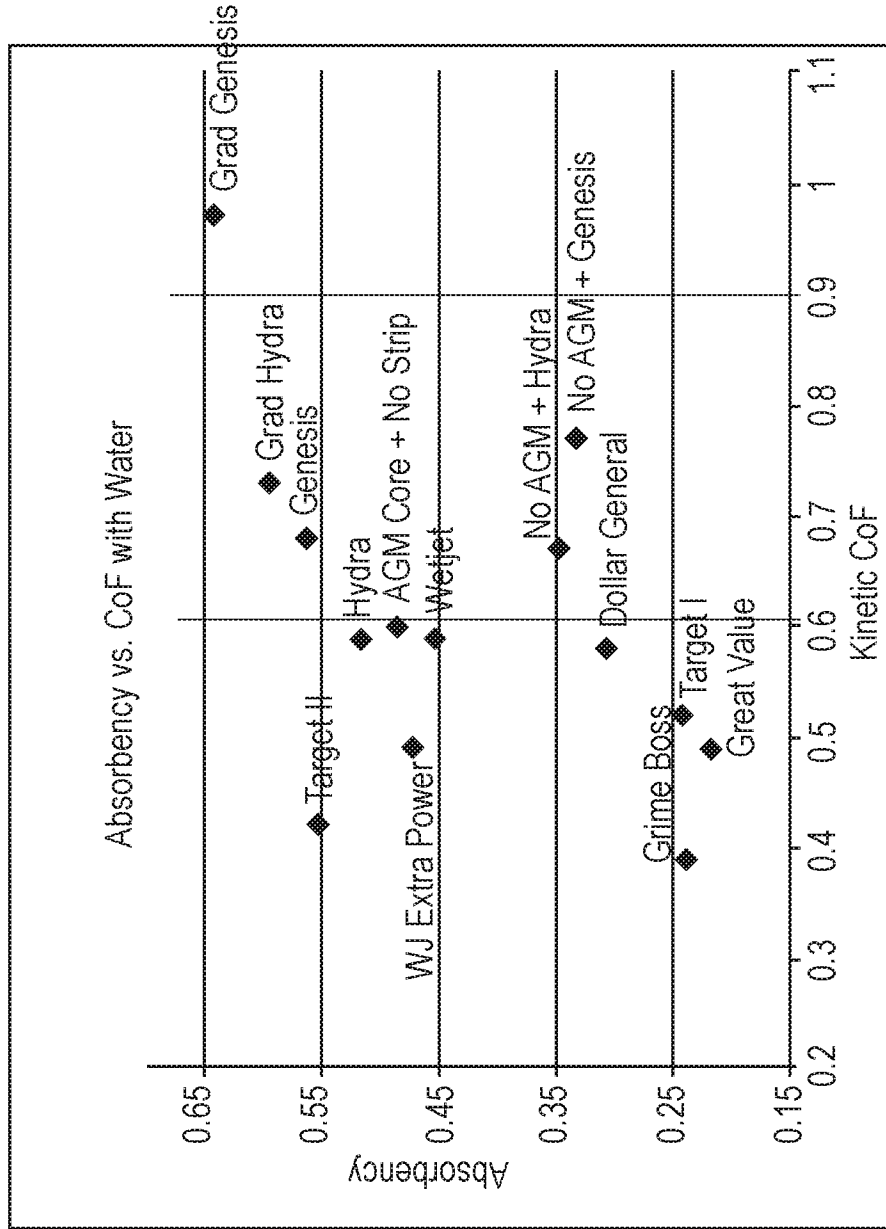

Fig. 3B

6/14

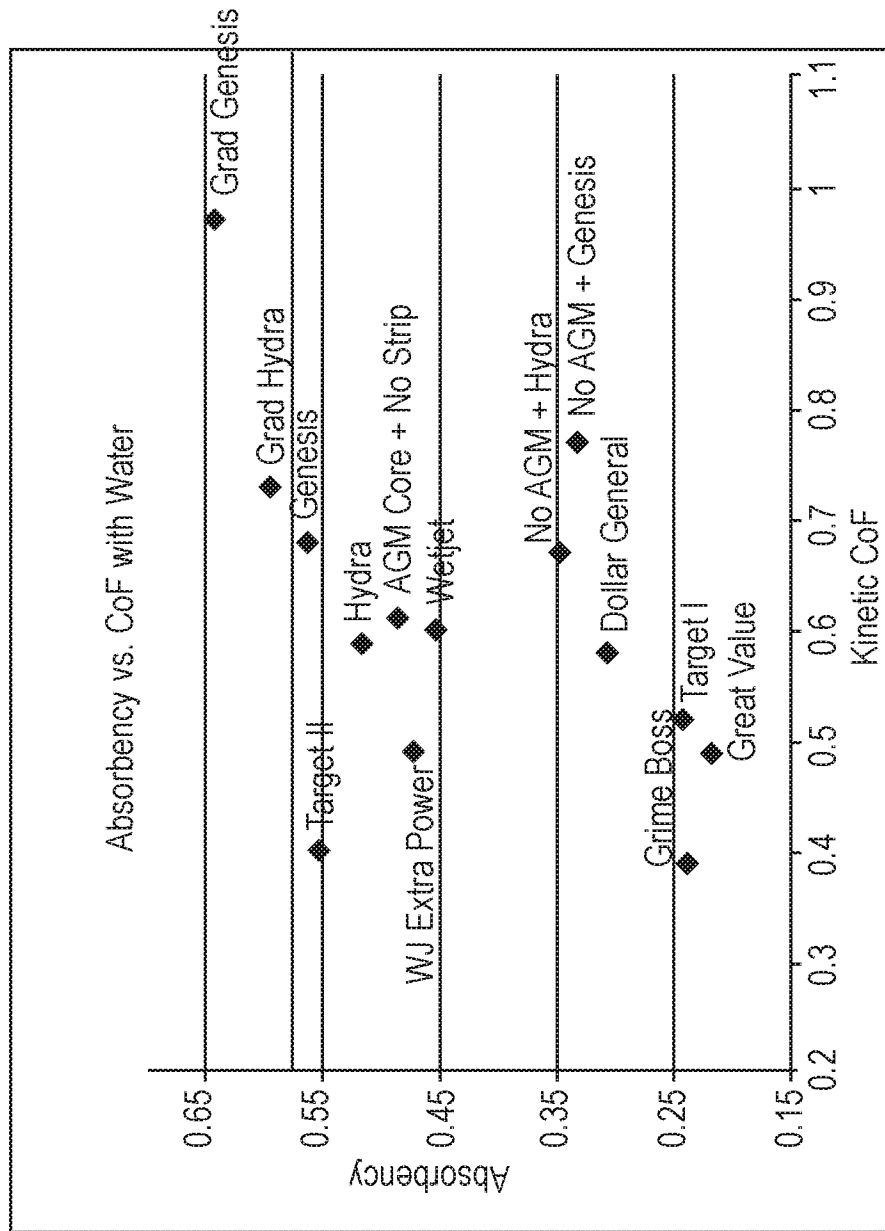

Fig. 3C

7/14

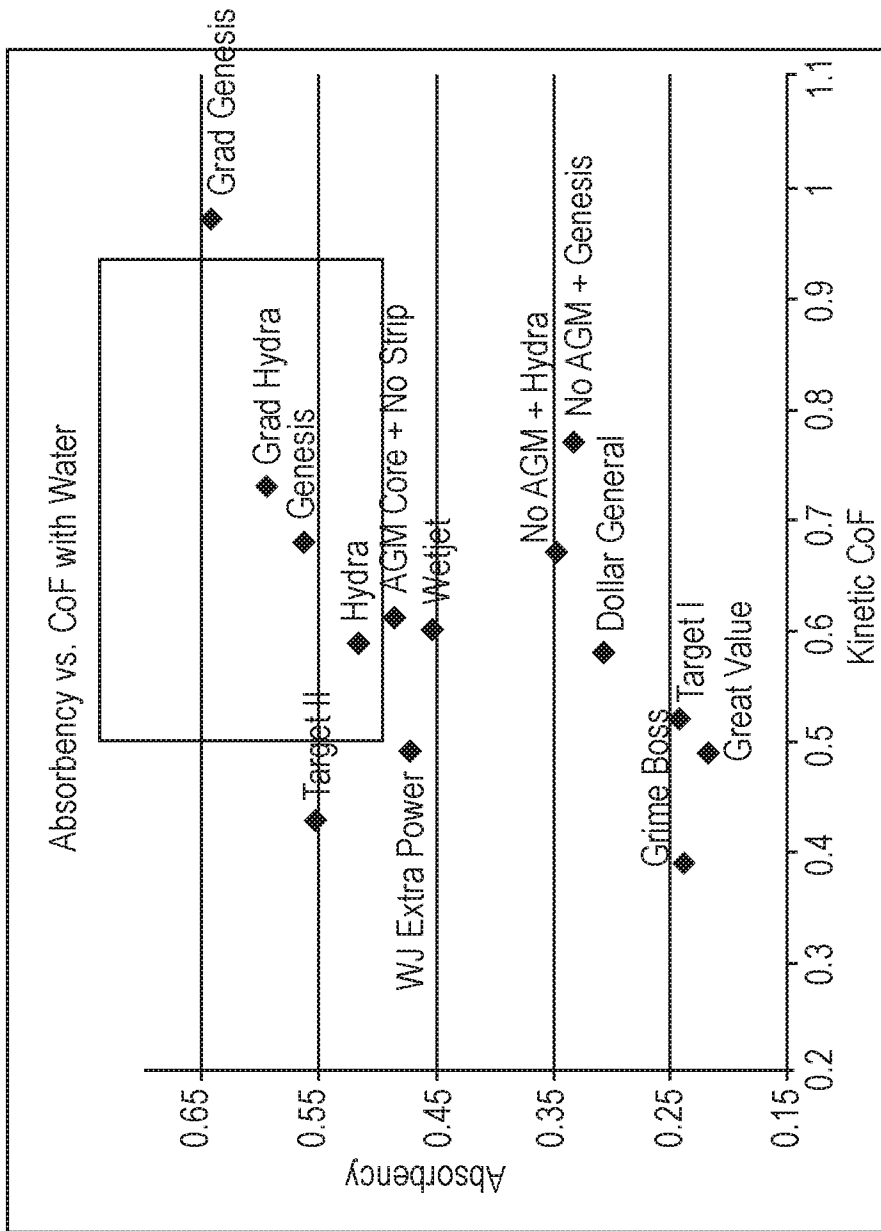

Fig. 3D



8/14

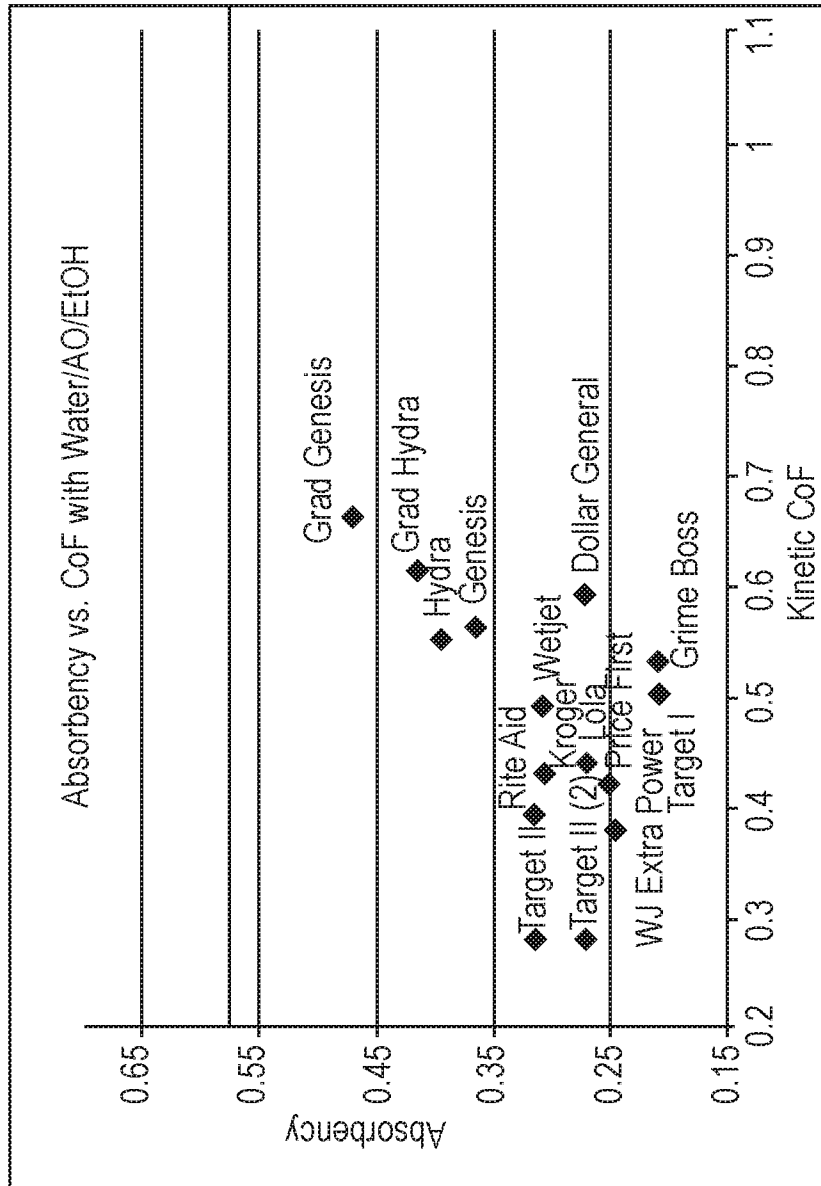

Fig. 4A

9/14

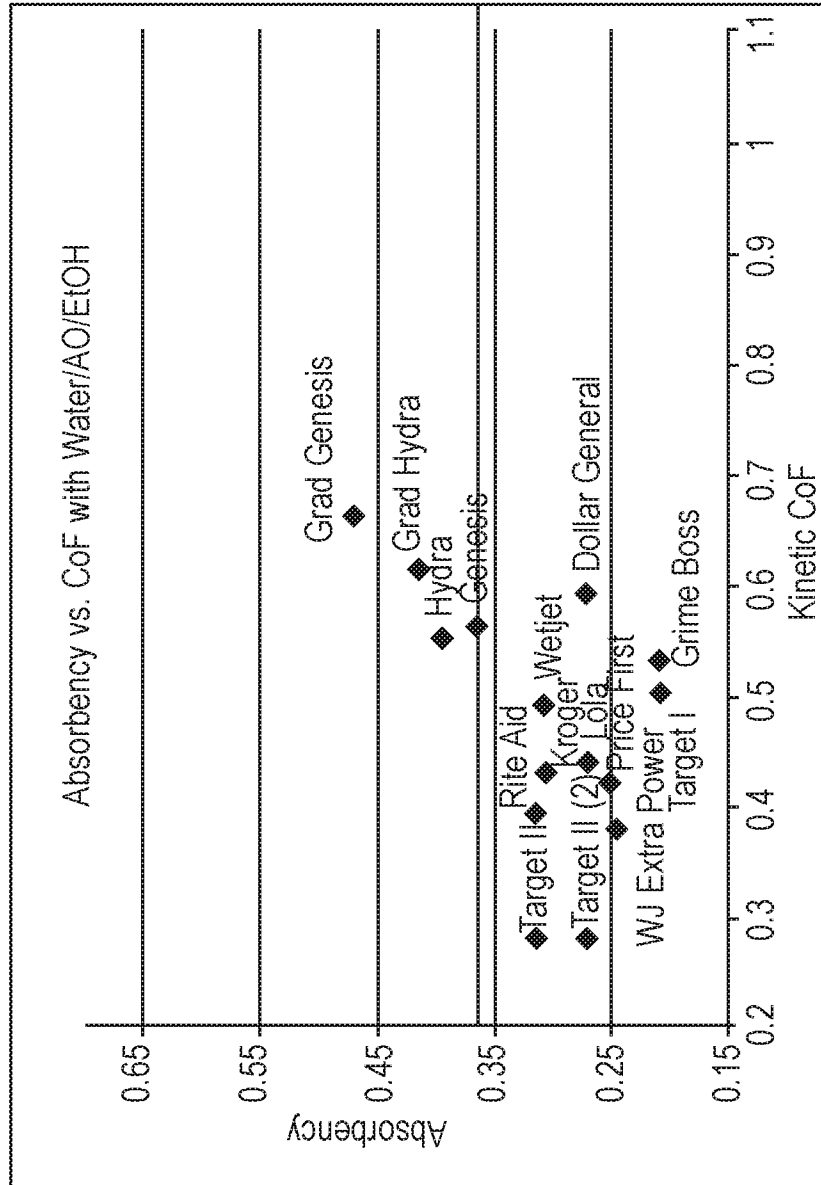

Fig. 4B

10/14

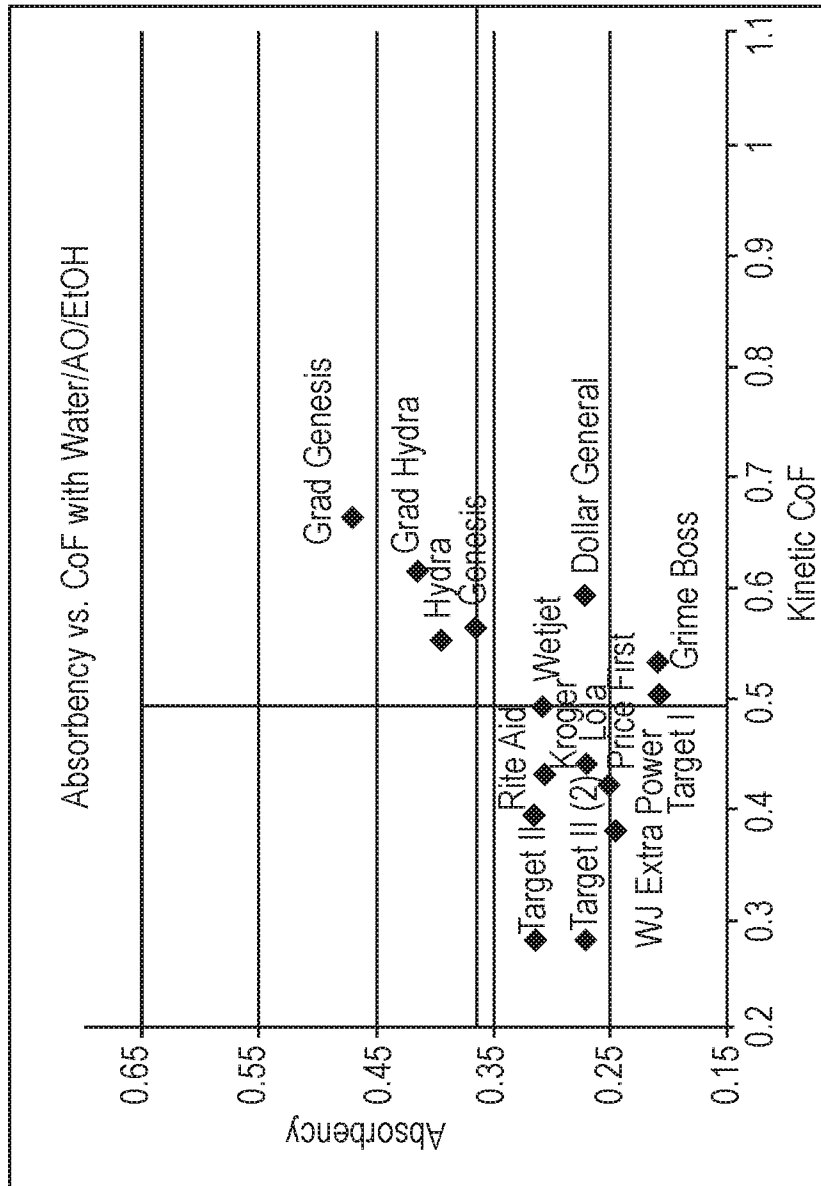

Fig. 4C

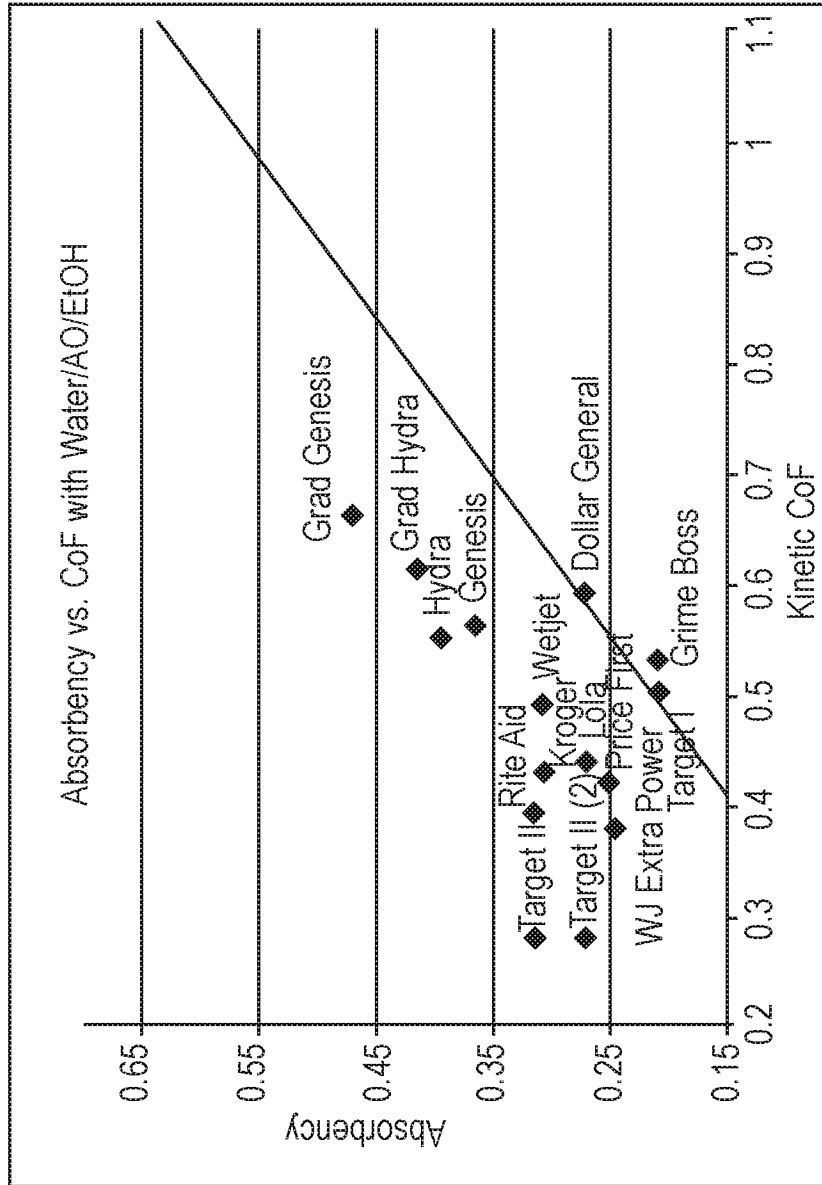

Fig. 4D

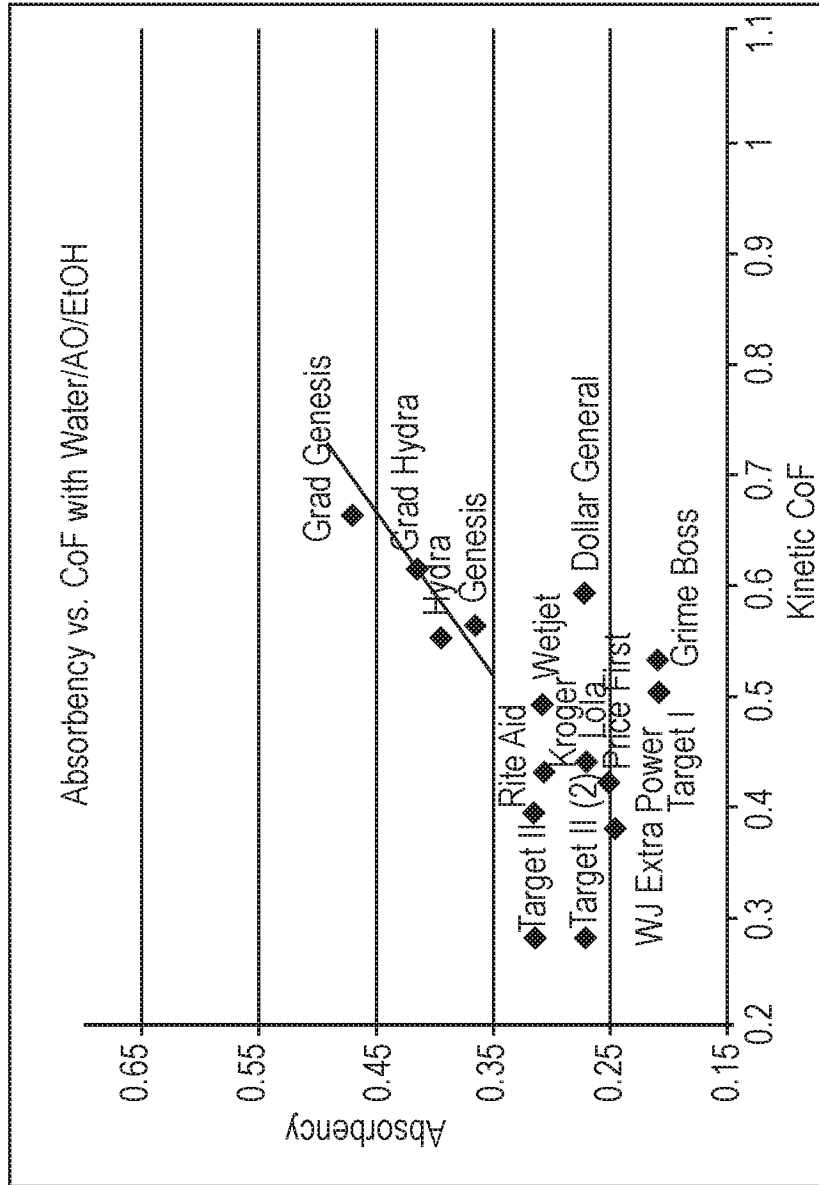

Fig. 4E

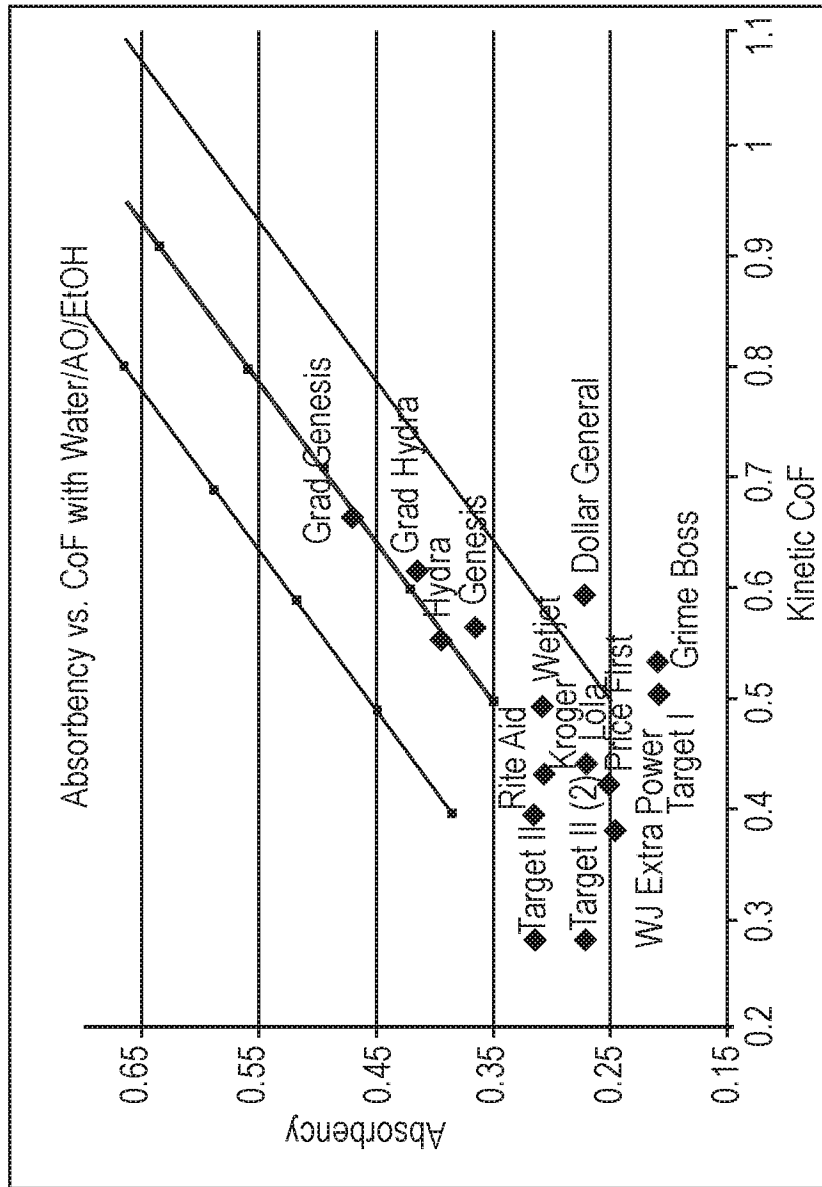
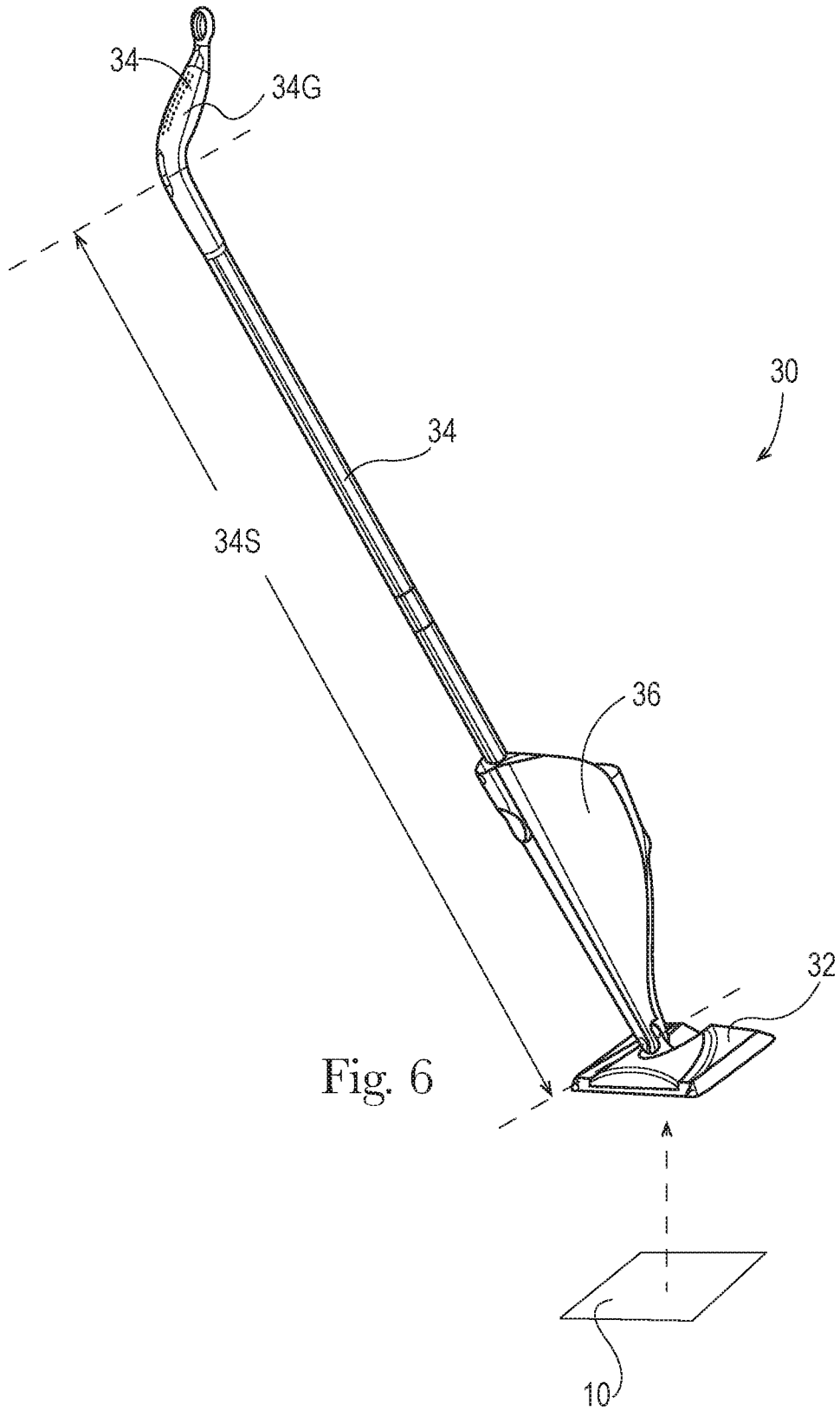

Fig. 4F



**INTERNATIONAL SEARCH REPORT**

International application No  
PCT/US2016/054373

**A. CLASSIFICATION OF SUBJECT MATTER**  
INV. A47L13/256  
ADD.  
  
According to International Patent Classification (IPC) or to both national classification and IPC

**B. FIELDS SEARCHED**  
Minimum documentation searched (classification system followed by classification symbols)  
A47L  
  
Documentation searched other than minimum documentation to the extent that such documents are included in the fields searched

Electronic data base consulted during the international search (name of data base and, where practicable, search terms used)  
EPO-Internal, WPI Data

**C. DOCUMENTS CONSIDERED TO BE RELEVANT**

Category*	Citation of document, with indication, where appropriate, of the relevant passages	Relevant to claim No.
X A	US 2005/076936 A1 (PUNG DAVID JOHN [US] ET AL) 14 April 2005 (2005-04-14) paragraphs [0081], [0092]; claims; figures -----	1-5,7-13 6,14
X A	US 2012/308780 A1 (ROETTGER HENNING [DE] ET AL) 6 December 2012 (2012-12-06) paragraphs [0028], [0156] - [0163]; claims; figures 1-4 -----	1-5,7-13 6,14
X A	US 6 048 123 A (HOLT STEVEN ALLEN [US] ET AL) 11 April 2000 (2000-04-11) cited in the application column 15, line 29 - column 16, line 34; figures 1-4 -----	1-5,7-13 6,14

Further documents are listed in the continuation of Box C.       See patent family annex.

\* Special categories of cited documents :

<p>"A" document defining the general state of the art which is not considered to be of particular relevance</p> <p>"E" earlier application or patent but published on or after the international filing date</p> <p>"L" document which may throw doubts on priority claim(s) or which is cited to establish the publication date of another citation or other special reason (as specified)</p> <p>"O" document referring to an oral disclosure, use, exhibition or other means</p> <p>"P" document published prior to the international filing date but later than the priority date claimed</p>	<p>"T" later document published after the international filing date or priority date and not in conflict with the application but cited to understand the principle or theory underlying the invention</p> <p>"X" document of particular relevance; the claimed invention cannot be considered novel or cannot be considered to involve an inventive step when the document is taken alone</p> <p>"Y" document of particular relevance; the claimed invention cannot be considered to involve an inventive step when the document is combined with one or more other such documents, such combination being obvious to a person skilled in the art</p> <p>"&amp;" document member of the same patent family</p>
---	---

Date of the actual completion of the international search  12 December 2016	Date of mailing of the international search report  10/02/2017
---	--

Name and mailing address of the ISA/ European Patent Office, P.B. 5818 Patentlaan 2 NL - 2280 HV Rijswijk Tel. (+31-70) 340-2040, Fax: (+31-70) 340-3016	Authorized officer  Lopez Vega, Javier
--	--



# INTERNATIONAL SEARCH REPORT

International application No.  
PCT/US2016/054373

## Box No. II Observations where certain claims were found unsearchable (Continuation of item 2 of first sheet)

This international search report has not been established in respect of certain claims under Article 17(2)(a) for the following reasons:

1.  Claims Nos.:  
because they relate to subject matter not required to be searched by this Authority, namely:
  
2.  Claims Nos.:  
because they relate to parts of the international application that do not comply with the prescribed requirements to such an extent that no meaningful international search can be carried out, specifically:
  
3.  Claims Nos.:  
because they are dependent claims and are not drafted in accordance with the second and third sentences of Rule 6.4(a).

## Box No. III Observations where unity of invention is lacking (Continuation of item 3 of first sheet)

This International Searching Authority found multiple inventions in this international application, as follows:

see additional sheet

1.  As all required additional search fees were timely paid by the applicant, this international search report covers all searchable claims.
  
2.  As all searchable claims could be searched without effort justifying an additional fees, this Authority did not invite payment of additional fees.
  
3.  As only some of the required additional search fees were timely paid by the applicant, this international search report covers only those claims for which fees were paid, specifically claims Nos.:
  
4.  No required additional search fees were timely paid by the applicant. Consequently, this international search report is restricted to the invention first mentioned in the claims; it is covered by claims Nos.:

1-14

### Remark on Protest

- The additional search fees were accompanied by the applicant's protest and, where applicable, the payment of a protest fee.
- The additional search fees were accompanied by the applicant's protest but the applicable protest fee was not paid within the time limit specified in the invitation.
- No protest accompanied the payment of additional search fees.

**FURTHER INFORMATION CONTINUED FROM PCT/ISA/ 210**

This International Searching Authority found multiple (groups of) inventions in this international application, as follows:

1. claims: 1-14

Cleaning pad with gradient distribution of the absorbent gelling material

---

2. claim: 15

Cleaning pad with hydrophilic smoothing strip

---

# INTERNATIONAL SEARCH REPORT

Information on patent family members

International application No

PCT/US2016/054373

Patent document cited in search report	Publication date	Patent family member(s)	Publication date	
US 2005076936	A1	14-04-2005	CA 2541795 A1	21-04-2005
			CN 1863477 A	15-11-2006
			EP 1680005 A1	19-07-2006
			JP 2007507324 A	29-03-2007
			MX PA06003953 A	05-07-2006
			US 2005076936 A1	14-04-2005
			WO 2005034710 A1	21-04-2005
-----				
US 2012308780	A1	06-12-2012	CA 2782112 A1	03-06-2011
			CN 102821720 A	12-12-2012
			DE 102009055951 A1	01-06-2011
			EP 2503974 A1	03-10-2012
			RU 2012126673 A	20-01-2014
			US 2012308780 A1	06-12-2012
			US 2014094361 A1	03-04-2014
			US 2016243522 A1	25-08-2016
WO 2011063975 A1	03-06-2011			
-----				
US 6048123	A	11-04-2000	AU 733654 B2	17-05-2001
			BR 9711532 A	24-08-1999
			CA 2266783 A1	26-03-1999
			CN 1238667 A	15-12-1999
			CN 1669519 A	21-09-2005
			DE 69710083 D1	14-03-2002
			DE 69710083 T2	10-10-2002
			EP 0929250 A1	21-07-1999
			ES 2167020 T3	01-05-2002
			JP 2000507480 A	20-06-2000
			MA 24326 A1	01-04-1998
			RU 2154397 C1	20-08-2000
			US 6048123 A	11-04-2000
			US 2003135948 A1	24-07-2003
US 2004206372 A1	21-10-2004			
WO 9811812 A1	26-03-1998			
-----				