



(22) **Date de dépôt/Filing Date:** 2015/08/25

(41) **Mise à la disp. pub./Open to Public Insp.:** 2017/02/25

(45) **Date de délivrance/Issue Date:** 2023/07/18

(51) **Cl.Int./Int.Cl. G09G 5/00** (2006.01),
G06F 3/14 (2006.01), **G02C 7/00** (2006.01)

(72) **Inventeurs/Inventors:**
HOUGH, NATHAN L., BB;
HOUGH, CHRISTOPHER J. S., BB;
SHARPE, JENNIFER K., BB;
HOUGH, RYAN M., BB;
VIGEANT, LUKE A., CA

(73) **Propriétaire/Owner:**
EVOLUTION OPTIKS LIMITED, VG

(74) **Agent:** MERIZZI RAMSBOTTOM & FORSTER

(54) **Titre : SYSTEME DE CORRECTION DE LA VISION, METHODE ET INTERFACE UTILISATEUR GRAPHIQUE DESTINEE A LA MISE EN PLACE DE DISPOSITIFS ELECTRONIQUES AYANT UN AFFICHEUR GRAPHIQUE**

(54) **Title: VISION CORRECTION SYSTEM, METHOD AND GRAPHICAL USER INTERFACE FOR IMPLEMENTATION ON ELECTRONIC DEVICES HAVING A GRAPHICAL DISPLAY**

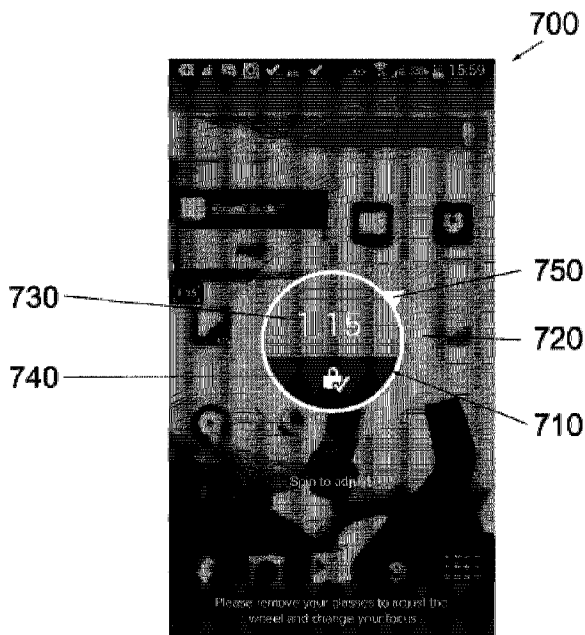

(57) **Abrégé/Abstract:**

Described are various embodiments of an electronic device having an adjustable graphical display, and a vision correction system, method and graphical user interface therefor. In one embodiment, a device is described for use by a prescribed user having reduced visual acuity, comprising: a digital display; a hardware processor; and a computer-readable medium having statements and instructions stored thereon for execution by said hardware processor in correcting an output image to be rendered by the digital display in accordance with a designated image correction that at least partially compensates for the user's reduced visual acuity.

ABSTRACT

Described are various embodiments of an electronic device having an adjustable graphical display, and a vision correction system, method and graphical user interface therefor. In one embodiment, a device is described for use by a prescribed user having reduced visual acuity, comprising: a digital display; a hardware processor; and a computer-readable medium having statements and instructions stored thereon for execution by said hardware processor in correcting an output image to be rendered by the digital display in accordance with a designated image correction that at least partially compensates for the user's reduced visual acuity.

VISION CORRECTION SYSTEM, METHOD AND GRAPHICAL USER INTERFACE
FOR IMPLEMENTATION ON ELECTRONIC DEVICES HAVING A GRAPHICAL
DISPLAY

FIELD OF THE DISCLOSURE

5 **[0001]** The present disclosure relates to electronic devices having a graphical display, and in particular, to a vision correction system, method and graphical user interface for implementation on such electronic devices.

BACKGROUND

10 **[0002]** The operating systems of current electronic devices having graphical displays offer certain “Accessibility” features built into the software of the device to attempt to provide users with reduced vision the ability to read and view content on the electronic device. Specifically, current accessibility options include the ability to invert images, increase the image size, adjust brightness and contrast settings, bold text, view the device display only in grey, and for those with legal blindness, the use of speech technology.

15 **[0003]** These techniques focus on the limited ability of software to manipulate display images through conventional image manipulation, with limited success. Other techniques, as reported for example in Fu-Chung Huang, Gordon Wetzstein, Brian A. Barsky, and Ramesh Raskar. "Eyeglasses-free Display: Towards Correcting Visual Aberrations with Computational Light Field Displays". *ACM Transaction on Graphics*, xx:0, Aug. 2014, have resulted either in a low-contrast image, a low-resolution image, or both. In any event, current techniques have thus far failed to provide a reliable solution for electronic device users having reduced visual acuity and who may wish to interact with their device’s graphical display without the use of corrective eyewear, for example.

25 **[0004]** Furthermore, current techniques generally involve device-specific implementations based on device-resident image adjustment controls and parameters requiring direct user configuration.

[0005] This background information is provided to reveal information believed by the applicant to be of possible relevance. No admission is necessarily intended, nor should be construed, that any of the preceding information constitutes prior art.

SUMMARY

5 **[0006]** The following presents a simplified summary of the general inventive concept(s) described herein to provide a basic understanding of some aspects of the invention. This summary is not an extensive overview of the invention. It is not intended to restrict key or critical elements of the invention or to delineate the scope of the invention beyond that which is explicitly or implicitly described by the following description and
10 claims.

[0007] A need exists for a vision correction system, method and graphical user interface for implementation on electronic devices having a graphical display, that overcome some of the drawbacks of known techniques, or at least, provide a useful alternative thereto. Some aspects of disclosure provide embodiments of such systems,
15 methods, GUIs and devices.

[0008] In accordance with one aspect, there is provided an electronic device for use by a prescribed user having reduced visual acuity, the device comprising: a digital display; a hardware processor; and a computer-readable medium having statements and instructions stored thereon for execution by said hardware processor in correcting an output image to
20 be rendered by said digital display in accordance with a designated image correction, wherein said image correction function receives as input at least one designated user-specific vision correction parameter selected from a plurality of available correction parameters to correspond with the reduced visual acuity of the user and thereby output a correspondingly corrected output image; wherein output of said correspondingly corrected
25 output image via said digital display at least partially compensates for the user's reduced visual acuity.

[0009] In one embodiment, said digital display comprises a light-field display having a digital output display screen and a light-field display optics layered thereon and defined

by at least one light-field optics parameter, and wherein said image correction function comprises an image pre-filtering function that receives as input said at least one light-field optics parameter and said at least one designated user-specific vision correction parameter to output said correspondingly corrected output image via said light-field display. In one such embodiment, the light-field display optics comprises a pinhole mask forming a parallax barrier light-field display. In another such embodiment, the light-field display optics comprises a lenslet array.

[0010] In one embodiment, said computer-readable medium has further statements and instructions stored thereon for execution by said hardware processor to implement and render an interactive graphical user interface (GUI) on said display, wherein said interactive GUI incorporates a dynamic vision correction scaling function that dynamically adjusts said at least one vision correction parameter in real-time in response to a designated user interaction therewith via said GUI.

[0011] In one such embodiment, said dynamic vision correction scaling function comprises a graphically rendered scaling function and wherein said designated user interaction comprises a continuous slide motion operation, and wherein said GUI is configured to capture and translate a user's given continuous slide motion operation to a corresponding adjustment to said vision correction parameter scalable with a degree of said user's given slide motion operation. In one such embodiment, said graphically rendered scaling function comprises a substantially circular graphical scale and wherein said continuous slide motion operation consists of a substantially circular motion on said substantially circular graphical scale. In another such embodiment, said light-field display comprises a touch-sensitive display and wherein said designated user interaction comprises a recognizable touch-activated gesture on said touch-sensitive display.

[0012] In one embodiment, the electronic device further comprises a communication interface operable to communicate over a network with a network-accessible vision correction resource having stored in association therewith said plurality of available correction parameters and a user profile associated with the user; wherein said user profile has stored in association therewith said at least one designated vision correction parameter;

and wherein identification of said user profile is communicated by the electronic device to said network-accessible resource via said communication interface to access said at least one designated vision correction parameter therefrom. In one such embodiment, the electronic device further comprises statements and instructions that, when executed by said hardware processor, render a user login interface that receives as input user profile credentials and relays said user credentials to said network-accessible vision correction resource to access said at least one designated vision correction parameter therefrom. In another such embodiment, a given user profile is rendered accessible in response to a corresponding user login via two or more distinct electronic devices. In another such embodiment, said at least one designated vision correction parameter is automatically calculated by a hardware processor associated with said network-accessible resource as a function of at least one user visual acuity factor input by the user via the electronic device and communicated to the network-accessible resource via said communication interface for storage against said user profile, wherein said user visual acuity factor comprises at least one of a user demographic and a predefined user vision correction prescription.

[0013] In one embodiment, the device consists of a digital vehicle user interface, a digital watch, or a digital reader.

[0014] In one embodiment, the device further comprises an onboard or remotely interfaceable digital camera operable to display an image captured by said camera on said digital display such that said captured image is automatically corrected in accordance with said vision correction function for consumption by the user via said digital display.

[0015] In one embodiment, said computer-readable medium has further statements and instructions stored thereon for execution by said hardware processor to implement and render an interactive graphical user interface (GUI) on said digital display, wherein said interactive GUI incorporates a vision toggle function that dynamically toggles responsive to user action between distinct predefined vision correction modes. In one such embodiment, said distinct predefined vision correction modes include a non-corrected mode.

[0016] In accordance with another aspect, there is provided a computer-readable medium having statements and instructions stored thereon for execution by a hardware processor to implement a vision correction application on an electronic device having a digital display to at least partially compensate for a user's reduced visual acuity, said statements and instructions executable by said hardware processor to: access at least one designated user vision correction parameter selected from a plurality of available correction parameters to correspond with the reduced visual acuity of the user; correct an output image of the electronic device in accordance with a designated image correction function to output a correspondingly corrected output image, wherein said image correction function receives as input said at least one designated user vision correction parameter; and output said correspondingly corrected output image via said digital display so to at least partially compensate for the user's reduced visual acuity.

[0017] In accordance with one embodiment, said computer-readable medium has further statements and instructions stored thereon for execution by said hardware processor to implement and render an interactive graphical user interface (GUI) on said digital display, wherein said interactive GUI incorporates a dynamic vision correction scaling function that dynamically adjusts said at least one vision correction parameter in real-time in response to a designated user interaction therewith via said GUI. In one such embodiment, said dynamic vision correction scaling function comprises a graphically rendered scaling function and wherein said designated user interaction comprises a continuous slide motion operation, and wherein said GUI is configured to capture and translate a user's given continuous slide motion operation to a corresponding adjustment to said vision correction parameter scalable with a degree of said user's given slide motion operation. In one such embodiment, said graphically rendered scaling function comprises a substantially circular graphical scale and wherein said continuous slide motion operation consists of a substantially circular motion on said substantially circular graphical scale.

[0018] In one embodiment, the computer-readable medium further comprises statements and instructions to implement and render an interactive graphical user interface (GUI) on said digital display, wherein said interactive GUI incorporates a vision toggle function that dynamically toggles responsive to user action between distinct predefined

vision correction modes corresponding to distinct vision correction parameters. In one such embodiment, said distinct predefined vision correction modes include a non-corrected mode.

5 [0019] In one embodiment, said computer-readable medium further comprises statements and instructions to process an image captured by an onboard or remotely interfaceable camera such that said captured image is automatically corrected in accordance with said vision correction function for consumption by the user via said digital display.

10 [0020] In one embodiment, the computer-readable medium is operable to access a display distance parameter representative of a distance between the user and the digital display and execute said vision correction function as a function of said distance. In one such embodiment, said display distance parameter is predefined as an average distance of the display screen in operation. In another such embodiment, the computer-readable medium is executable on distinct device types, and wherein said display distance parameter
15 is predefined for each of said distinct device types. In another such embodiment, said average distance is at least partially defined for each given user as a function of a demographic of said given user.

[0021] In accordance with another aspect, there is provided a network-enabled vision correction system to implement vision correction on a plurality of electronic devices, each
20 having a digital output display screen, a hardware processor, a computer-readable medium, and a communication interface, the system comprising: a network-accessible vision correction server having stored in association therewith a user profile for each system user, wherein each said user profile has stored in association therewith a respective system user identifier and at least one respective vision correction parameter selected from a plurality
25 of vision correction parameters to at least partially correspond with a reduced visual acuity of said respective system user; a software application executable on each of the devices and comprising statements and instructions executable by the hardware processor thereof in correcting an output image to be rendered by the digital display thereof in accordance with a designated image correction function, wherein said image correction function

receives as input said at least one vision correction parameter accessed from a given user profile as selected for a given system user, and thereby outputs a correspondingly corrected output image via said digital display to at least partially compensate for a reduced visual acuity of said given system user.

5 [0022] In one embodiment, the system further comprises a light-field optics to be layered on the digital output display screen of each of the devices, wherein said light-field optics is defined by at least one light-field optics parameter, and wherein said image correction function is configured to account for said light-field optics parameter in correcting said output image.

10 [0023] In one embodiment, said software application further comprises statements and instructions that, when executed by the hardware processor, render a user login, authentication or identification interface that receives as input user profile credentials, authentication or identification metrics, and relays said user credentials or metrics to said server in accessing said at least one vision correction parameter therefrom.

15 [0024] In one embodiment, said at least one vision correction parameter is automatically calculated by a server-accessible hardware processor as a function of at least one user visual acuity factor input by the user via the electronic device and communicated to said server via the communication interface for storage against said user profile, wherein said user visual acuity factor comprises at least one of a user demographic and a predefined
20 user vision correction prescription.

[0025] In one embodiment, the system further comprises the plurality of electronic devices.

[0026] In one embodiment, said user login interface enables any given user to access its at least one vision correction parameter via respective electronic devices and have any
25 said respective electronic device output said correspondingly corrected output image via said digital display upon successful login therewith.

[0027] In one embodiment, said user profile is remotely accessible upon user identification from any of said electronic devices so to execute said correspondingly

corrected output image via any of said electronic devices in response to said user identification.

[0028] In one embodiment, said electronic devices comprises any one or more of cellular telephones, smartphones, smart watches or other smart devices, an onboard vehicle navigation or entertainment system, a network interfaceable vehicle dashboard and/or controls, and the like.

[0029] In accordance with another aspect, there is provided a network-enabled vision correction method to implement vision correction on a plurality of electronic devices, each having a digital output display screen, a hardware processor, a computer-readable medium, and a communication interface, the method comprising: providing access to a vision correction application executable on each of the remote electronic devices to correct an output image to be rendered by the digital display in accordance with a designated image correction function; storing on a remote server a respective user profile for each of a plurality of registered users, and storing in association therewith at least one designated vision correction parameter corresponding with a respective reduced visual acuity for each of said registered user and a respective digital user identifier usable in remotely identifying each of said registered users; receiving at an application server over the network a given digital user identifier from a given registered user operating any given one of the remote electronic devices; the application server: identifying said given registered user against a corresponding stored user profile as a function of said given digital user identifier; retrieving said at least one designated vision correction parameter stored in association therewith; and transmitting said at least one designated vision correction parameter over the network to said given one of the remote electronic devices so to invoke execution of said designated image correction function thereon based at least in part on said at least one designated vision correction parameter and thereby output a correspondingly corrected output image via the digital display to at least partially compensate for a reduced visual acuity of said given registered user.

[0030] In one embodiment, the vision correction application is further executable to graphically render a real-time vision correction adjustment interface that dynamically

adjusts said at least one designated vision correction parameter in real-time responsive to user interaction with said interface in dynamically adjusting said corrected output image accordingly, and digitally record an adjusted vision correction parameter corresponding to a preferred corrected output image setting selected by said given registered user user via
5 said interface, wherein the method further comprises: receiving over the network a vision correction parameter adjustment command at said application server from said given one of the remote electronic devices indicative of said adjusted vision correction parameter; and storing said adjusted vision correction parameter against said given user profile.

[0031] As introduced above, and in accordance with some aspects, a method and system are provided for the correction of vision on an electronic device, for instance where
10 a combination of resident software and hardware on a user's electronic device can be dynamically controlled to manipulate the image displayed thereby in order to make the image clearer, at least to some significant level, to users with reduced visual acuity and/or visual impairments, commonly referred to herein as reduced visual acuity. For example,
15 the software and hardware combination may allow for vision corrections similar to that achievable using conventional prescription lens, adjusting any one of more of a rendered image's hue, contrast, and brightness, for example.

[0032] In some embodiments, the system may be configured to invoke a server-based calibration process that not only allows for the centralized management of a user's
20 calibration parameters, which may facilitate, enhance or enable various user-centric account or profile features such as calibration portability between user, public or shared devices, but also allow for the accumulation, tracking and analysis of calibration parameters from multiple users or subscribers. The latter may be used to better predict and deliver more accurate display correction settings to each user based on similarities observed
25 between reported user conditions and selected settings, thus further enabling the provision of visual settings that allow a greater cross section of the population to use their device without the need for corrective lenses.

[0033] In accordance with another aspect, there is provided an electronic device for a user having reduced visual acuity to fine tune a prescription thereof corresponding with

their reduced visual acuity, the device comprising: a digital light-field display comprising a single digital output display screen and a light-field display optics layered thereon and defined by a light-field optics parameter; a hardware processor; and a non-transitory computer-readable medium having statements and instructions stored thereon for execution
5 by the hardware processor in correcting an output image to be rendered by the digital light-field display in accordance with an image pre-filtering function. The image pre-filtering function receives as input said light-field display optics parameter and a progressively adjustable vision correction parameter that corresponds to vision correction prescriptions and that is progressively adjusted to output, in real-time, a correspondingly corrected output
10 image until the correspondingly corrected output image is observed by the user via the digital light-field display to compensate for the user's reduced visual acuity and thereby fine tune their prescription.

[0034] In some embodiments, the fined tuned prescription is automatically calculated from a designated vision correction parameter corresponding thereto.

15 **[0035]** In some embodiments, the progressively adjustable vision correction parameter is adjusted to fine tune the prescription based on a time of day.

[0036] In some embodiments, the progressively adjustable vision correction parameter is adjusted to fine tune the prescription based on ambient lighting.

[0037] In some embodiments, the non-transitory computer-readable medium has
20 further statements and instructions stored thereon for execution by the hardware processor to implement and render an interactive graphical user interface (GUI) on the display, wherein the interactive GUI incorporates a dynamic vision correction scaling function that dynamically adjusts said progressively adjustable vision correction parameter in real-time in response to a designated interaction therewith via the GUI.

25 **[0038]** In some embodiments, the dynamic vision correction scaling function comprises a graphically rendered scaling function and wherein the designated interaction comprises a continuous slide motion operation, and wherein the GUI is configured to capture and translate a given continuous slide motion operation to a corresponding

adjustment to said progressively adjustable vision correction parameter scalable with a degree of said given slide motion operation.

[0039] In some embodiments, the graphically rendered scaling function comprises a substantially circular graphical scale and wherein the continuous slide motion operation
5 consists of a substantially circular motion on the substantially circular graphical scale.

[0040] In some embodiments, the electronic device further comprises a communication interface operable to communicate over a network with a network-accessible vision correction resource having stored in association therewith a user profile associated with the user; wherein identification of the user profile is communicated by the electronic device to
10 the network-accessible resource via the communication interface to store a designated vision correction parameter corresponding with the fine-tuned prescription.

[0041] In some embodiments, a given user profile, and the designated vision correction parameter stored in association therewith, are rendered accessible in response to a corresponding user login via a distinct electronic device.

[0042] In some embodiments, the fined tuned prescription is automatically calculated
15 from the designated vision correction parameter.

[0043] In some embodiments, the light-field display optics comprises a parallax barrier, or a lenslet array.

[0044] In some embodiments, the electronic device further comprises a front-facing
20 camera, wherein a distance from the digital display and the user is calculated using information retrieved from the front-facing camera, and wherein the image pre-filtering function receives said distance as input to output the correspondingly corrected output image as a function thereof.

[0045] In accordance with another aspect, there is provided a non-transitory computer-
25 readable medium having statements and instructions stored thereon for execution by a hardware processor to implement an application on an electronic device, the electronic device comprising a light-field display which comprises a single digital output display

screen and a light-field display optics layered thereon defined by a light-field optics parameter, the application for a user having reduced visual acuity to fine tune a prescription thereof corresponding with their reduced visual acuity, the statements and instructions executable by said hardware processor to: progressively adjust a progressively adjustable vision correction parameter corresponding to vision correction prescriptions; correct an output image of the electronic device in accordance with an image pre-filtering function that receives as input said light-field optics parameter and said progressively adjustable vision correction parameter to output a correspondingly corrected output image via said single digital output display screen; and progressively output, in real-time, the correspondingly corrected output image via the single digital output display screen and the light-field display optics layered thereon until the correspondingly corrected output image is observed by the user via the single digital display to compensate for the user's reduced visual acuity and thereby fine tune their prescription.

[0046] In some embodiments, the non-transitory computer-readable medium has further statements and instructions stored thereon for execution by the hardware processor to implement and render an interactive graphical user interface (GUI) on the digital output display screen, wherein the interactive GUI incorporates a dynamic vision correction scaling function that dynamically adjusts the vision correction parameter in real-time in response to a designated interaction therewith via the GUI, wherein the dynamic vision correction scaling function comprises a graphically rendered scaling function and wherein the designated interaction comprises a continuous slide motion operation, and wherein the GUI is configured to capture and translate a given continuous slide motion operation to a corresponding adjustment to the vision correction parameter scalable with a degree of the given slide motion operation.

[0047] In some embodiments, the progressively adjustable vision correction parameter is adjusted to fine tune the prescription based on a time of day.

[0048] In some embodiments, the progressively adjustable vision correction parameter is adjusted to fine tune the prescription based on ambient lighting.

[0049] In some embodiments, the non-transitory computer-readable medium further comprises statements and instructions operable to cause the hardware processor to access a display distance parameter representative of a distance between the user and the digital output display screen and execute the image pre-filtering function as a function of distance.

5 **[0050]** In accordance with another aspect, there is provided a method for fine tuning a vision correction prescription for a user having a reduced visual acuity, the method comprising: rendering an output image for visualization by the user via a digital light-field display comprising a single digital output display screen and a light-field display optics layered thereon defined by a light-field optics parameter; correcting the output image in
10 accordance with an image pre-filtering function that receives as input the light-field optics parameter and a progressively adjustable vision correction parameter corresponding to vision correction prescriptions to output a correspondingly corrected output image via the single digital output display screen; progressively adjusting the progressively adjustable vision correction parameter to progressively output, in real-time, the correspondingly
15 corrected output image via the single digital output display screen and the light-field display optics layered thereon until the correspondingly corrected output image is observed by the user via the single digital display to compensate for the user's reduced visual acuity and thereby fine tune their prescription.

[0051] In some embodiments, a device, system, or method may employ a front-facing
20 camera, wherein a distance from a digital display and the user is calculated using information retrieved from the front-facing camera, and wherein the image pre-filtering function receives the distance as input to output the correspondingly corrected output image as a function thereof.

[0052] Other aspects, features and/or advantages will become more apparent upon
25 reading of the following non-restrictive description of specific embodiments thereof, given by way of example only with reference to the accompanying drawings.

BRIEF DESCRIPTION OF THE FIGURES

[0053] Several embodiments of the present disclosure will be provided, by way of examples only, with reference to the appended drawings, wherein:

[0054] Figure 1 is a diagrammatical view of an electronic device having an adjustable graphical display, in accordance with one embodiment;

5 [0055] Figure 2 is an exploded view of a graphical display mask for use in cooperation with an adjustable graphical display of an electronic device and showing an enlarged portion of a pinhole layer thereof, in accordance with one embodiment;

[0056] Figures 3A and 3B are exploded and side views, respectively, of an assembly of the graphical display mask of Figure 2 overlaying an adjustable graphical display of an electronic device to produce a parallax barrier light field display, in accordance with one
10 embodiment;

[0057] Figure 4 is a partial diagrammatic representation of an effect of the parallax barrier light field display of Figures 3A and 3B;

[0058] Figure 5 is a flow chart of an image pre-filtering process to be applied in pre-
15 filtering an image to be displayed by the display of the electronic device of Figures 3A and 3B through the mask layered thereon, in accordance with one embodiment;

[0059] Figure 6A is a flow chart of a user login process for a server-based vision correction system, in accordance with one embodiment;

[0060] Figure 6B is a flow chart continuing from the flow chart of Figure 6a and
20 showing various user options selectable through a graphical user interface rendered on the user's device and cooperatively implemented via the server-based vision correction system, in accordance with one embodiment;

[0061] Figure 7 is an exemplary screenshot of a graphical user interface rendered on a
25 user's electronic device and implemented in respect of a vision correction system to show a calibration screen thereof, in accordance with one embodiment;

[0062] Figure 8 is a flow chart of server-based process for retrieving and delivering recommended vision correction parameters to a user's device in response to input user prescription and/or demographic information, in accordance with one embodiment;

5 **[0063]** Figure 9 is an exemplary screenshot of a graphical user interface rendered on a user's electronic device and implemented in respect of a vision correction system to show a vision correction application launching screen thereof, in accordance with one embodiment;

[0064] Figure 10 is an exemplary screenshot of a graphical user interface rendered on a user's electronic device and implemented in respect of a vision correction system to show
10 new account setup screen thereof, in accordance with one embodiment;

[0065] Figure 11 is an exemplary screenshot of a graphical user interface rendered on a user's electronic device and implemented in respect of a vision correction system to show a service plan selection screen thereof, in accordance with one embodiment;

15 **[0066]** Figure 12 is an exemplary screenshot of a graphical user interface rendered on a user's electronic device and implemented in respect of a vision correction system to show an access password reset screen thereof, in accordance with one embodiment;

[0067] Figure 13 is an exemplary screenshot of a graphical user interface rendered on a user's electronic device and implemented in respect of a vision correction system to show a user profile screen thereof, in accordance with one embodiment; and

20 **[0068]** Figures 14A to D are exemplary screenshots of a graphical user interface rendered on a user's electronic device and implemented in respect of a vision correction system to show a sequence of dynamically updated vision correction calibration screens thereof in which an applied vision correction is updated in real-time in response to an incremental user input applied thereto, in accordance with one embodiment.

25 **DETAILED DESCRIPTION**

[0069] The systems and methods described herein provide, in accordance with different embodiments, different examples an electronic device having an adjustable

graphical display, and a vision correction system, method and graphical user interface therefor.

[0070] Figure 1 illustrates an electronic device 100 according to an embodiment. Electronic device 100, while depicted as a cellular telephone, is not limited to a cellular telephone. Other devices capable of implementing the disclosed embodiments include, for example, smartphones, tablets, e-readers, watches, televisions, GPS devices, laptops, and desktop computers. Likewise, an onboard vehicle entertainment or control module having a digital screen output or the like may also be considered, as can a digital watch, such as smart watch or the like. Any electronic device capable of performing the present embodiments is considered to be within the scope of electronic device 100.

[0071] Electronic device 100 includes a processing unit 110, a display 120, and internal memory 130. Display 120 can be an LCD screen, a monitor, a plasma display panel, an e-mounted display, or any other type of electronic display. Internal memory 130 can be any form of electronic storage, including a disk drive, optical drive, read-only memory, random-access memory, or flash memory. Memory 130 has stored in it vision correction application 140. Electronic device 100 may optionally include a front-facing camera 150, and an accelerometer 160. Accelerometer 160 is capable of determining the tilt and/or orientation of electronic device 100.

[0072] Figure 2 illustrates a pinhole mask 200 according to one embodiment. Pinhole mask 200 comprises a piece of transparent material, such as transparency plastic. Other transparent materials may be used instead of transparency plastic. Printed on pinhole mask 200 is a pattern of pinholes. The enlargement in Fig. 2 shows this pattern more clearly. In one embodiment, the size of the pinholes is dependent upon, and slightly less than, the size of the individual pixels of display 120. For example, in one embodiment, the pixels of display 120 are each 78 microns wide, and the pinholes are each 75 microns in diameter. The size of the pinhole also represents a tradeoff between brightness and diffraction, with the former preferably to be maximized and the latter preferably to be minimized. In one embodiment, the pinholes are spaced 390 microns apart.

[0073] Figures 3A and 3B illustrates a vision correcting device 300 according to one embodiment. Vision correcting device 300 comprises electronic device 100, with transparent spacer 310 on top of display 120. On top of transparent spacer 310 is pinhole mask 200. On top of pinhole mask 200 is optional screen protector 320. In Figures 3A and 3B, the width of transparent spacer 310, pinhole mask 200, and screen protector 310 are not drawn to scale. In one embodiment, the thickness of spacer 310 is 4 millimetres.

[0074] The device of Figures 3A and 3B creates a parallax barrier light field display. Figure 4 shows, in part, the effect of the parallax barrier light field display of Figures 3A and 3B. This display has a number of views that is calculated by dividing the separation of the pinholes by the width of the pixels of the display.

[0075] In the embodiment shown in Figure 4, the display would have 5 ($390 \div 78$) views. In addition, the field of view (θ) can be calculated via the following formula:

$$\theta = \tan^{-1} \frac{\Delta x}{d}$$

where Δx is the pinhole separation and d is the width of spacer 310.

[0076] While Figures 2 and 3 describe an embodiment that uses a pinhole mask to create a parallax barrier light field display, other light field display technologies, such as lenslet arrays and multilayer designs, are within the scope of the present disclosure.

[0077] In one embodiment, vision correction application 140 runs as a process on processing unit 110 of electronic device 100. As it runs, it pre-filters the output of display 120.

[0078] Figure 5 illustrates a pre-filtering method according to one embodiment. This method describes the process by which the images displayed on screen 120 are pre-filtered according to stored vision correction parameters.

[0079] In step 500, a user's vision correction parameters are retrieved from internal memory 130, which may permanently store the user's vision correction parameter(s) or again retrieve them from an external database upon user login and/or client application

launch. For instance, in the latter example, the user's current vision correction parameter(s) may be actively stored and accessed from an external database operated within the context of a server-based vision correction subscription system or the like, and/or unlocked for local access via the client application post user authentication with the server-based system.

5 **[0080]** In optional step 502, on electronic devices that include front-facing camera 150, the distance from the screen to the user is calculated using information retrieved from front-facing camera 150.

[0081] In optional step 504, on electronic devices that include accelerometer 160, the tilt and orientation of electronic device 100 are retrieved from accelerometer 160.

10 **[0082]** In step 506, the vision correction information and, if applicable, the distance from the screen to the user and/or the tilt and orientation of electronic device 100 are used as input to an image pre-filtering function to pre-filter the image.

[0083] Several different pre-filtering algorithms may be used for this step, either alone or in combination, including deconvolution algorithms, an iterative Richardson-Lucy algorithm, an all-pass kernel pre-filtering algorithm, and a light field pre-filtering algorithm. Some examples of pre-filtering algorithms are described in Fu-Chung Huang, Gordon Wetzstein, Brian A. Barsky, and Ramesh Raskar. "Eyeglasses-free Display: Towards Correcting Visual Aberrations with Computational Light Field Displays". *ACM Transaction on Graphics*, xx:0, Aug. 2014.

20 **[0084]** In step 508, the pre-filtered image is displayed on screen 120 as a corrected output image.

[0085] In step 510, the light field emitted from the pre-filtered display passes through pinhole mask 200, and is diffracted by pinhole mask 200.

25 **[0086]** Through the method illustrated in Figure 5, a user can view a corrected image without the need for glasses or other vision correction implements.

[0087] In yet another example, the user of a camera-enabled electronic device may use this function, along with the image correction capabilities described herein, to read or view

printed or other materials via the electronic device rather than directly. For example, a user of a camera-enabled smartphone may use their smartphone as a visual aid to read a menu at a restaurant or a form at a medical appointment by activating the vision correction application along with a back-facing camera feature of the application (or again simply
5 activating the camera function of the smartphone), and pointing the phone to the hardcopy materials to be viewed. By virtue of the image correction application, while the camera may automatically focus on the image, the rendered image on the screen will be displayed so to correct for the user's visual acuity and thus, may appear somewhat blurred or out of focus to an individual with perfect vision, but appear perfectly clearly to the user as if he
10 were otherwise wearing their glasses.

[0088] With reference to Figure 6A, and in accordance with one embodiment, a method will be described for launching and operating a vision correction application from a client device in communication with a remote server operated to provide client access to vision correction data, user services and subscriptions, and the like. The illustrated method starts
15 in step 600, where a user of electronic device 100 starts vision correction application 140 in a way appropriate to the type of electronic device being used. For example, if the electronic device is a smartphone, the user touches the icon corresponding to vision correction application 140.

[0089] In step 602, a screen, such as that shown for example at Figure 9, is displayed
20 to the user, giving the user the option of logging in (if the user is already registered) or registering as a new user.

[0090] With reference to Figure 10, and in accordance with one embodiment, an illustrative registration screen is provided in which a new user may be asked to provide their full name, email address, phone number, password (e.g. to secure use of their vision
25 correction application, user profile and/or subscription information such as payment options and credentials), and the like, thereby setting up a new user profile for the user as basis for their use of the client application.

[0091] With reference to Figure 11, and in accordance with one embodiment, the new user may then be asked to select a payment option, such as an annual or yearly subscription

basis, or again offered the option of purchasing a gift card for the purpose of offering vision correction application services to a friend or family member as a gift. Other registration steps and features may also be performed without departing from the general scope and nature of the present disclosure, such as entering payment or prepayment information, user demographics usable in tailoring user services and/or compiling user data and/or statistics, and the like.

[0092] With reference again to Figure 6, in step 604, an otherwise registered user selects the option to log in, and enters his or her account information. The account information is verified according to standard methods known by those of ordinary skill in the art. The account information may include information about the user's Facebook, Twitter, Google+, or any other social media account. Where a user has forgotten their credentials, they may be directed to a reset password screen, such as that shown in Figure 12, in which the registered user may enter the email address associated with their user profile and subsequently receive a reset password via that email address. Other approaches can also be considered, as will be appreciated by the skilled artisan.

[0093] In step 606, in response to a successful login, the user's information is retrieved from an external database. This information includes preset or current vision correction parameters. This information may also include eye prescription information. The eye prescription information may include the following data: left eye near spherical, right eye near spherical, left eye distant spherical, right eye distant spherical, left eye near cylindrical, right eye near cylindrical, left eye distant cylindrical, right eye distant cylindrical, left eye near axis, right eye near axis, left eye distant axis, right eye distant axis, left eye near prism, right eye near prism, left eye distant prism, right eye distant prism, left eye near base, right eye near base, left eye distant base, and right eye distant base. The eye prescription information may also include the date of the eye exam and the name of the eye doctor that performed the eye exam.

[0094] In step 608, the retrieved information is used to pre-filter the display as described above with respect to the method in Figure 500.

[0095] Figure 13 provides an illustrative example of a user profile screen, for example shown upon successful launch of the client application, and in which various user and/or device profile information may be included. For example, the profile screen may include the name of the user's device(s) enabled to operate the vision correction application, a subscription status message (e.g. noting time left before a next payment is due) and details, the profile's creation date, the date of the user's last eye exam and the name of the physician who performed the exam, the current prescription value (e.g. 4.75), as well as various optional function buttons providing access to, for example, different subscription renewal options and/or payment screens, the option to add a new user profile under a same subscription package (e.g. a family package or package for shared users of a same device), and various other add-ons, for example.

[0096] In step 610, the user selects an option to refocus the display, for example via an "edit profile" button rendered on the profile screen.

[0097] In step 612, a calibration screen is presented to the user. Figure 7 shows calibration screen 700 in one embodiment. In this embodiment, the calibration screen comprises a circular area 710 in the center of the screen, surrounded by a circular track 720. Circular area 710 comprises a parameter display area 730 and a button 740. Input pointer 750 can move around circular track 720 responsive to input from the user.

[0098] In step 614, the user moves input pointer 750 around circular track 720. As input pointer 750 is moved, the vision correction information is updated based on the position of input pointer 750. In addition, the image on display 120 is adjusted based on the updated vision correction information.

[0099] With reference to Figures 14A to D, operation of the calibration screen 700 of Figure 7 is shown in sequence while illustrating a dynamic effect such operation has on a visibility to the user of the calibration screen's background image as the vision correction parameter(s) is/are dynamically adjusted in real-time. For example, the image is shown to sharpen progressively as the effective prescription rating progresses continuously from 0.25 in Figure 14A, to 2.0 in Figure 14B, to 2.98 in Figure 14C, but is then overshoot as the effective prescription rating jumps to 5.43 at Figure 14D. Accordingly, the user may fine

tune their effective prescription rating, either as their visual acuity changes over time or perhaps for different times of the day or under different ambient lighting conditions, or generally as a preference using different devices and/or setting.

5 **[00100]** The method of inputting and/or calibrating the vision correction information is not limited to the calibration screen shown in Figure 7 and Figures 14A to D. Other methods for inputting the vision correction information will be readily apparent to one of ordinary skill in the art, and may include manually inputting the parameter, moving a linear slider control, selecting a point on a grid, or any other method for inputting a parameter.

10 **[00101]** In step 616, the user presses button 740 and the vision correction information is saved in the external database for later retrieval.

[00102] In step 618, the user selects an option to input prescription and demographic information.

15 **[00103]** In step 620, a prescription input screen is presented to the user. This screen includes data entry fields for each of the prescription information settings. The user then inputs the prescription information and the prescription information is saved in internal memory 130.

20 **[00104]** Alternatively, a left eye prescription input screen may be presented to the user first, followed by a right eye prescription input screen. In this embodiment, the user inputs the corresponding prescription information in each screen and the prescription information is saved in the external database.

[00105] In step 622, a demographic information input screen is presented to the user. The screen includes data entry fields for demographic information, e.g. race, sex and age. The user then inputs the demographic information and the demographic information is stored in the external database.

25 **[00106]** In step 624, the prescription and demographic information is associated with the user's vision correction information in the external database.

[00107] In step 626, the user selects an option to enable/disable the vision correcting function of vision correction application 140.

[00108] In step 628, if the vision correcting function was enabled, it is disabled. If it was disabled, it is enabled. The state of the vision correcting function, whether enabled or
5 disabled, is stored in internal memory 130 of electronic device 100.

[00109] The present disclosure also contemplates a method for recommending vision correction parameters based on a user's prescription and demographic information. This method is described below with respect to Figure 8.

[00110] In step 800, the user inputs prescription and demographic information as in
10 steps 620 and 622 of the method of Figure 6.

[00111] In step 802, the user's prescription and demographic information are sent to the external database.

[00112] In step 804, the external database computes recommended vision correction parameters based on the user's prescription and demographic information. The database
15 computes these parameters using the vision correction parameters of other users with similar prescription and demographic information.

[00113] In step 806, the external database sends the recommended vision correction parameters to electronic device 100.

[00114] While the present disclosure describes various exemplary embodiments, the
20 disclosure is not so limited. To the contrary, the disclosure is intended to cover various modifications and equivalent arrangements included within the general scope of the present disclosure.

CLAIMS

What is claimed is:

1. An electronic device for use by a prescribed user having reduced visual acuity, the device comprising:

a digital display;

a hardware processor; and

a computer-readable medium having statements and instructions stored thereon for execution by said hardware processor in correcting an output image to be rendered by said digital display in accordance with a designated image correction, wherein said image correction function receives as input at least one designated user-specific vision correction parameter selected from a plurality of available correction parameters to correspond with the reduced visual acuity of the user and thereby output a correspondingly corrected output image;

wherein output of said correspondingly corrected output image via said digital display at least partially compensates for the user's reduced visual acuity,

wherein said digital display is a light-field display including a single digital output display screen and a light-field display optics layered thereon and defined by at least one light-field optics parameter so to concurrently produce a number of controllable angularly defined display views, and

wherein said image correction function comprises an image pre-filtering function that receives as input said at least one light-field optics parameter and said at least one designated user-specific vision correction parameter to output said correspondingly corrected output image via said light-field display in accordance with said number of controllable angularly defined display views;

wherein said computer-readable medium has further statements and instructions stored thereon for execution by said hardware processor to implement an interactive user interface, wherein said interactive user interface incorporates a dynamic vision correction scaling function that dynamically adjusts said at least one vision correction parameter in real-time in response to a designated interaction therewith via said interactive user interface.

2. The electronic device of claim 1, wherein said light-field display optics comprises a parallax barrier.

3. The electronic device of claim 1, wherein said light-field display optics comprises a lenslet array.

4. The electronic device of any one of claims 1 to 3, wherein said computer-readable medium has further statements and instructions stored thereon for execution by said hardware processor to implement and render an interactive graphical user interface (GUI) on said display, wherein said interactive GUI incorporates said dynamic vision correction scaling function that dynamically adjusts said at least one vision correction parameter in real-time in response to said designated user interaction therewith via said GUI.

5. The electronic device of claim 4, wherein said dynamic vision correction scaling function comprises a graphically rendered scaling function and wherein said designated user interaction comprises a continuous slide motion operation, and wherein said GUI is configured to capture and translate a user's given continuous slide motion operation to a corresponding adjustment to said vision correction parameter scalable with a degree of said user's given slide motion operation.

6. The electronic device of claim 5, wherein said graphically rendered scaling function comprises a circular graphical scale and wherein said continuous slide motion operation consists of a circular motion on said circular graphical scale.

7. The electronic device of any one of claims 4 to 6, wherein said light-field display comprises a touch-sensitive display and wherein said designated user interaction comprises a recognizable touch-activated gesture on said touch-sensitive display.

8. The electronic device of any one of claims 1 to 7, further comprising a communication interface operable to communicate over a network with a network-accessible vision correction resource having stored in association therewith said plurality of available correction parameters and a user profile associated with the user;

wherein said user profile has stored in association therewith said at least one designated vision correction parameter; and

wherein identification of said user profile is communicated by the electronic device to said network-accessible resource via said communication interface to access said at least one designated vision correction parameter therefrom.

9. The electronic device of claim 8, wherein said computer-readable medium has further statements and instructions stored thereon that, when executed by said hardware processor, render a user login interface that receives as input user profile credentials and relays said user credentials to said network-accessible vision correction resource to access said at least one designated vision correction parameter therefrom, and wherein a given user profile is rendered accessible in response to a corresponding user login via two or more distinct electronic devices.

10. The electronic device of either one of claim 8 or claim 9, wherein said at least one designated vision correction parameter is automatically calculated by a hardware processor associated with said network-accessible resource as a function of at least one user visual acuity factor input by the user via the electronic device and communicated to the network-accessible resource via said communication interface for storage against said user profile, wherein said user visual acuity factor comprises at least one of a user demographic and a predefined user vision correction prescription.

11. The electronic device of any one of claims 1 to 10, wherein the device comprises a digital vehicle user interface, a digital watch, or a digital reader.

12. The electronic device of any one of claims 1 to 10, wherein the device further comprises an onboard or remotely interfaceable digital camera operable to display an image captured by said camera on said digital display such that said captured image is automatically corrected in accordance with said vision correction function for consumption by the user via said digital display.

13. The electronic device of any one of claims 1 to 10, wherein said computer-readable medium has further statements and instructions stored thereon for execution by said hardware processor to implement and render an interactive graphical user interface (GUI) on said digital display, wherein said interactive GUI incorporates a vision toggle function that dynamically

toggles responsive to user action between distinct predefined vision correction modes, and wherein said distinct predefined vision correction modes include a non-corrected mode.

14. A computer-readable medium having statements and instructions stored thereon for execution by a hardware processor to implement a vision correction application on an electronic device including a light-field display which comprises a single digital output display screen and a light-field display optics layered thereon and is defined by at least one light-field optics parameter, to at least partially compensate for a user's reduced visual acuity, said statements and instructions executable by said hardware processor to:

access at least one designated user vision correction parameter selected from a plurality of available correction parameters to correspond with the reduced visual acuity of the user;

correct an output image of the electronic device in accordance with a designated image correction function to output a correspondingly corrected output image via said single digital output display screen, wherein said image correction function comprises an image pre-filtering function that receives as input said at least one light-field optics parameter and said at least one designated user vision correction parameter so to concurrently produce a number of controllable angularly defined display views; and

output said correspondingly corrected output image via said single digital output display screen and said light-field display optics layered thereon in accordance with said number of controllable angularly defined display views so to at least partially compensate for the user's reduced visual acuity;

wherein said computer-readable medium has further statements and instructions stored thereon for execution by said hardware processor to implement an interactive user interface, wherein said interactive user interface incorporates a dynamic vision correction scaling function that dynamically adjusts said at least one vision correction parameter in real-time in response to a designated user interaction therewith.

15. The computer-readable medium of claim 14, wherein said computer-readable medium has further statements and instructions stored thereon for execution by said hardware processor to implement and render an interactive graphical user interface (GUI) on said digital output display screen, wherein said interactive GUI incorporates said dynamic vision correction scaling function that dynamically adjusts said at least one vision correction parameter in real-time in response to

said designated user interaction therewith via said GUI, wherein said dynamic vision correction scaling function comprises a graphically rendered scaling function and wherein said designated user interaction comprises a continuous slide motion operation, and wherein said GUI is configured to capture and translate a user's given continuous slide motion operation to a corresponding adjustment to said vision correction parameter scalable with a degree of said user's given slide motion operation.

16. The computer-readable medium of claim 15, wherein said graphically rendered scaling function comprises a circular graphical scale and wherein said continuous slide motion operation consists of a circular motion on said circular graphical scale.

17. The computer-readable medium of claim 14, wherein the computer-readable medium further comprises statements and instructions to implement and render an interactive graphical user interface (GUI) on said digital output display screen, wherein said interactive GUI incorporates a vision toggle function that dynamically toggles responsive to user action between distinct predefined vision correction modes corresponding to distinct vision correction parameters, and wherein said distinct predefined vision correction modes include a non-corrected mode.

18. The computer-readable medium of claim 14, wherein said computer-readable medium further comprises statements and instructions to process an image captured by an onboard or remotely interfaceable camera such that said captured image is automatically corrected in accordance with said vision correction function for consumption by the user via said digital output display screen.

19. The computer-readable medium of claim 14, wherein the computer-readable medium further comprises statements and instructions operable to cause said hardware processor to access a display distance parameter representative of a distance between the user and the digital output display screen and execute said vision correction function as a function of said distance.

20. The computer-readable medium of claim 19, wherein said display distance parameter is predefined as an average distance of the display screen in operation.

21. The computer-readable medium of claim 19, wherein the computer-readable medium is executable on distinct device types, and wherein said display distance parameter is predefined for each of said distinct device types.

22. The computer-readable medium of claim 19, wherein said average distance is at least partially defined for each given user as a function of a demographic of said given user.

23. A network-enabled vision correction system to implement vision correction on a plurality of electronic devices, each including a single digital output display screen, a hardware processor, a computer-readable medium, and a communication interface, the system comprising:

a network-accessible vision correction server including stored in association therewith a user profile for each system user, wherein each said user profile includes stored in association therewith a respective system user identifier and at least one respective vision correction parameter selected from a plurality of vision correction parameters to at least partially correspond with a reduced visual acuity of said respective system user;

a software application executable on each of the devices, stored in the computer-readable medium thereof, and comprising statements and instructions executable by the hardware processor thereof in correcting an output image to be rendered by the single digital output display screen thereof in accordance with a designated image correction function, wherein said image correction function receives as input said at least one vision correction parameter accessed from a given user profile as selected for a given system user, and thereby outputs a correspondingly corrected output image via said digital display to at least partially compensate for a reduced visual acuity of said given system user; and

a light-field optics to be layered on the single digital output display screen of each of the devices, wherein said light-field optics is defined by at least one light-field optics parameter so to concurrently produce a number of controllable angularly defined display views, and wherein said image correction function is configured to account for said light-field optics parameter in correcting said output image in accordance with said number of controllable angularly defined display views;

wherein said software application is further executable to graphically render a real-time vision correction adjustment interface that dynamically adjusts said at least one designated vision correction parameter in real-time responsive to user interaction with said interface in dynamically

adjusting said corrected output image accordingly, and digitally record an adjusted vision correction parameter corresponding to a preferred corrected output image setting selected by said given registered user via said interface;

wherein said server further receives over the network a vision correction parameter adjustment command from said given one of the remote electronic devices indicative of said adjusted vision correction parameter; and stores said adjusted vision correction parameter against said given user profile.

24. The system of claim 23, wherein said software application further comprises statements and instructions that, when executed by the hardware processor, render a user login, authentication or identification interface that receives as input user profile credentials, authentication or identification metrics, and relays said user credentials or metrics to said server in accessing said at least one vision correction parameter therefrom.

25. The system of either one of claim 23 or claim 24, wherein said at least one vision correction parameter is automatically calculated by a server-accessible hardware processor as a function of at least one user visual acuity factor input by the user via the electronic device and communicated to said server via the communication interface for storage against said user profile, wherein said user visual acuity factor comprises at least one of a user demographic and a predefined user vision correction prescription.

26. The system of any one of claims 23 to 25, further comprising the plurality of electronic devices.

27. The system of claim 24, wherein said user login interface enables any given user to access its at least one vision correction parameter via respective electronic devices and have any said respective electronic device output said correspondingly corrected output image via said digital display upon successful login therewith.

28. The system of claim 23, wherein said user profile is remotely accessible upon user identification from any of said electronic devices so to execute said correspondingly corrected output image via any of said electronic devices in response to said user identification.

29. The system of any one of claims 23 to 28, wherein said electronic devices comprise any one or more of cellular telephones, smartphones, smart watches, smart devices, an onboard vehicle navigation system, an onboard vehicle entertainment system, a network interfaceable vehicle dashboard or network interfaceable vehicle controls.

30. A network-enabled vision correction method to implement vision correction on a plurality of remote electronic devices, each having a single digital output display screen, a hardware processor, and a communication interface, the method comprising:

providing access to a vision correction application executable on each of the remote electronic devices to correct an output image to be rendered by the single digital output display screen, wherein said single digital output display screen comprises a light-field display optics layered thereon and defined by at least one light-field optics parameter so to concurrently produce a number of controllable angularly defined display views, in accordance with a designated image correction function, wherein said image correction function comprises an image pre-filtering function that receives as input said at least one light-field optics parameter and at least one designated vision correction parameter corresponding with a respective reduced visual acuity;

storing on a remote server a respective user profile for each of a plurality of registered users, and storing in association therewith said at least one designated vision correction parameter for each of said registered users and a respective digital user identifier usable in remotely identifying each of said registered users; and

receiving at an application server over the network a given digital user identifier from a given registered user operating any given one of the remote electronic devices;

the application server:

identifying said given registered user against a corresponding stored user profile as a function of said given digital user identifier;

retrieving said at least one designated vision correction parameter stored in association therewith; and

transmitting said at least one designated vision correction parameter over the network to said given one of the remote electronic devices so to invoke execution of said designated image correction function thereon based at least in part on said at least one designated vision correction parameter and thereby output a correspondingly corrected output image via the single digital output display

screen and said light-field display optics layered thereon in accordance with said number of controllable angularly defined display views to at least partially compensate for a reduced visual acuity of said given registered user; wherein said vision correction application is further executable to graphically render a real-time vision correction adjustment interface that dynamically adjusts said at least one designated vision correction parameter in real-time responsive to user interaction with said interface in dynamically adjusting said corrected output image accordingly, and digitally record an adjusted vision correction parameter corresponding to a preferred corrected output image setting selected by said given registered user via said interface, wherein the method further comprises:

receiving over the network a vision correction parameter adjustment command at said application server from said given one of the remote electronic devices indicative of said adjusted vision correction parameter; and

storing said adjusted vision correction parameter against said given user profile.

31. The system of claim 23, wherein each of said devices further comprises a front-facing camera, wherein a distance from said digital display and the user is calculated using information retrieved from said front-facing camera, and wherein said image correction function receives said distance as input to output said corrected output image as a function thereof.

32. The device of claim 1, further comprising a front-facing camera, wherein a distance from said digital display and the user is calculated using information retrieved from said front-facing camera, and wherein said image pre-filtering function receives said distance as input to output said correspondingly corrected output image as a function thereof.

33. An electronic device for a user having reduced visual acuity to fine tune a prescription thereof corresponding with their reduced visual acuity, the device comprising:

a single digital output display screen and a light-field optics layer defined by a light-field optics parameter;

a hardware processor; and

a non-transitory computer-readable medium having statements and instructions stored thereon for execution by said hardware processor in correcting an output image to be rendered by said single digital output display screen in accordance with an image pre-filtering function,

wherein said image pre-filtering function receives as input said light-field optics parameter and a progressively adjustable vision correction parameter that corresponds to vision correction prescriptions and that is progressively adjusted to output, in real-time, a correspondingly corrected output image until said correspondingly corrected output image is observed by the user via said single digital output display screen and light-field optics layer to compensate for the user's reduced visual acuity and thereby fine tune their prescription.

34. The electronic device of claim 33, wherein the fined tuned prescription is automatically calculated from a designated vision correction parameter corresponding thereto.

35. The electronic device of either one of claim 33 or claim 34, wherein said progressively adjustable vision correction parameter is adjusted to fine tune the prescription based on a time of day.

36. The electronic device of any one of claims 33 to 35, wherein said progressively adjustable vision correction parameter is adjusted to fine tune the prescription based on ambient lighting.

37. The electronic device of any one of claims 33 to 36, wherein said non-transitory computer-readable medium has further statements and instructions stored thereon for execution by said hardware processor to implement and render an interactive graphical user interface (GUI) on said display, wherein said interactive GUI incorporates a dynamic vision correction scaling function that dynamically adjusts said progressively adjustable vision correction parameter in real-time in response to a designated interaction therewith via said GUI.

38. The electronic device of claim 37, wherein said dynamic vision correction scaling function comprises a graphically rendered scaling function and wherein said designated interaction comprises a continuous slide motion operation, and wherein said GUI is configured to capture and translate a given continuous slide motion operation to a corresponding adjustment to said progressively adjustable vision correction parameter scalable with a degree of said given slide motion operation.

39. The electronic device of claim 38, wherein said graphically rendered scaling function comprises a circular graphical scale and wherein said continuous slide motion operation consists of a circular motion on said circular graphical scale.

40. The electronic device of any one of claims 33 to 39, further comprising a communication interface operable to communicate over a network with a network-accessible vision correction resource having stored in association therewith a user profile associated with the user; wherein identification of said user profile is communicated by the electronic device to said network-accessible resource via said communication interface to store a designated vision correction parameter corresponding with the fine-tuned prescription.

41. The electronic device of claim 40, wherein a given user profile, and said designated vision correction parameter stored in association therewith, are rendered accessible in response to a corresponding user login via a distinct electronic device.

42. The electronic device of claim 40, wherein the fined tuned prescription is automatically calculated from said designated vision correction parameter.

43. The electronic device of any one of claims 33 to 42, wherein said light-field optics layer comprises a parallax barrier.

44. The electronic device of any one of claims 33 to 42, wherein said light-field optics layer comprises a lenslet array.

45. The electronic device of any one of claims 33 to 44, further comprising a front-facing camera, wherein a distance from said digital output display screen and the user is calculated using information retrieved from said front-facing camera, and wherein said image pre-filtering function receives said distance as input to output said correspondingly corrected output image as a function thereof.

46. A non-transitory computer-readable medium having statements and instructions stored thereon for execution by a hardware processor to implement an application on an electronic device,

the electronic device comprising a single digital output display screen and a light-field optics layer defined by a light-field optics parameter, the application for a user having reduced visual acuity to fine tune a prescription thereof corresponding with their reduced visual acuity, said statements and instructions executable by said hardware processor to:

progressively adjust a progressively adjustable vision correction parameter corresponding to vision correction prescriptions;

correct an output image of the electronic device in accordance with an image pre-filtering function that receives as input said light-field optics parameter and said progressively adjustable vision correction parameter to output a correspondingly corrected output image via said single digital output display screen; and

progressively output, in real-time, said correspondingly corrected output image via said single digital output display screen and said light-field optics layer until said correspondingly corrected output image is observed by the user via said single digital output display screen and said light-field optics layer to compensate for the user's reduced visual acuity and thereby fine tune their prescription.

47. The non-transitory computer-readable medium of claim 46, wherein said non-transitory computer-readable medium has further statements and instructions stored thereon for execution by said hardware processor to implement and render an interactive graphical user interface (GUI) on said single digital output display screen, wherein said interactive GUI incorporates a dynamic vision correction scaling function that dynamically adjusts said vision correction parameter in real-time in response to a designated interaction therewith via said GUI, wherein said dynamic vision correction scaling function comprises a graphically rendered scaling function and wherein said designated interaction comprises a continuous slide motion operation, and wherein said GUI is configured to capture and translate a given continuous slide motion operation to a corresponding adjustment to said vision correction parameter scalable with a degree of said given slide motion operation.

48. The non-transitory computer-readable medium of either one of claim 46 or claim 47, wherein said progressively adjustable vision correction parameter is adjusted to fine tune the prescription based on a time of day.

49. The non-transitory computer-readable medium of any one of claims 46 to 48, wherein said progressively adjustable vision correction parameter is adjusted to fine tune the prescription based on ambient lighting.

50. The non-transitory computer-readable medium of any one of claims 46 to 49, wherein the non-transitory computer-readable medium further comprises statements and instructions operable to cause said hardware processor to access a display distance parameter representative of a distance between the user and the single digital output display screen and execute said image pre-filtering function as a function of said distance.

51. A method for fine tuning a vision correction prescription for a user having a reduced visual acuity, the method comprising:

rendering an output image for visualization by the user via a single digital output display screen and a light-field optics layer defined by a light-field optics parameter;

correcting said output image in accordance with an image pre-filtering function that receives as input said light-field optics parameter and a progressively adjustable vision correction parameter corresponding to vision correction prescriptions to output a correspondingly corrected output image via said single digital output display screen; and

progressively adjusting said progressively adjustable vision correction parameter to progressively output, in real-time, said correspondingly corrected output image via said single digital output display screen and said light-field optics layer until said correspondingly corrected output image is observed by the user via said single digital output display screen and said light-field optics layer to compensate for the user's reduced visual acuity and thereby fine tune their prescription.

52. A network-enabled system for use by users having reduced visual acuity to fine tune a respective prescription thereof corresponding with their respective reduced visual acuity, the system comprising:

a network-accessible vision correction server; and

a software application executable on each of a plurality of electronic devices, each of said devices comprising a single digital output display screen and a light-field optics layer defined by a light-field optics parameter, a hardware processor, a non-transitory computer-readable medium,

and a network communication interface, said software application comprising instructions executable by said hardware processor in correcting an output image to be rendered by said single digital output display screen in accordance with a designated image correction function, wherein said image correction function accounts for said light-field optics parameter and receives as input a progressively adjustable vision correction parameter that corresponds to vision correction prescriptions and that is progressively adjusted to output, in real-time, a correspondingly corrected output image until said correspondingly corrected output image is observed by a given user via said single digital output display screen and light-field optics layer of a given one of said devices to compensate for a reduced visual acuity of said given user and thereby fine tune their prescription.

53. The system of claim 52, further comprising an interactive graphical user interface (GUI) that incorporates a dynamic vision correction scaling function that dynamically adjusts said progressively adjustable vision correction parameter in real-time in response to a designated interaction therewith via said GUI.

54. The system of claim 52 or claim 53, wherein said server has stored in association therewith a user profile for each system user, wherein each said user profile includes stored in association therewith a respective system user identifier, wherein said fine tuned prescription is stored in association with said user profile for said given user.

55. The system of any one of claims 52 to 54, wherein the system comprises the plurality of electronic devices.

56. A network-enabled method for fine tuning a vision correction prescription for a user having a reduced visual acuity, the method comprising:

providing the user access to a vision correction application executable on a given one of a plurality of remote electronic devices, each of the devices comprising a single digital output display screen and a light-field optics layer defined by a light-field optics parameter, a hardware processor, a non-transitory computer-readable medium, and a network communication interface to a network-accessible vision correction server;

rendering an output image for visualization by the user via said single digital output display screen and light-field optics layer of said given device;

correcting said output image in accordance with an image correction function that receives as input said light-field optics parameter and a progressively adjustable vision correction parameter corresponding to vision correction prescriptions to output a correspondingly corrected output image via said single digital output display screen and light-field optics layer; and

progressively adjusting said progressively adjustable vision correction parameter to progressively output, in real-time, said correspondingly corrected output image via said single digital output display screen and said light-field optics layer until said correspondingly corrected output image is observed by the user via said single digital output display screen and said light-field optics layer to compensate for the user's reduced visual acuity and thereby fine tune their prescription.

57. The method of claim 56, wherein said server has stored in association therewith a user profile for each system user, wherein each said user profile includes stored in association therewith a respective system user identifier, and wherein the method further comprises storing said fine tuned prescription in association with said user profile for said given user.

58. The device of any one of claims 33 to 45, wherein said light-field optics layer is layered on or spaced from said single digital output display screen.

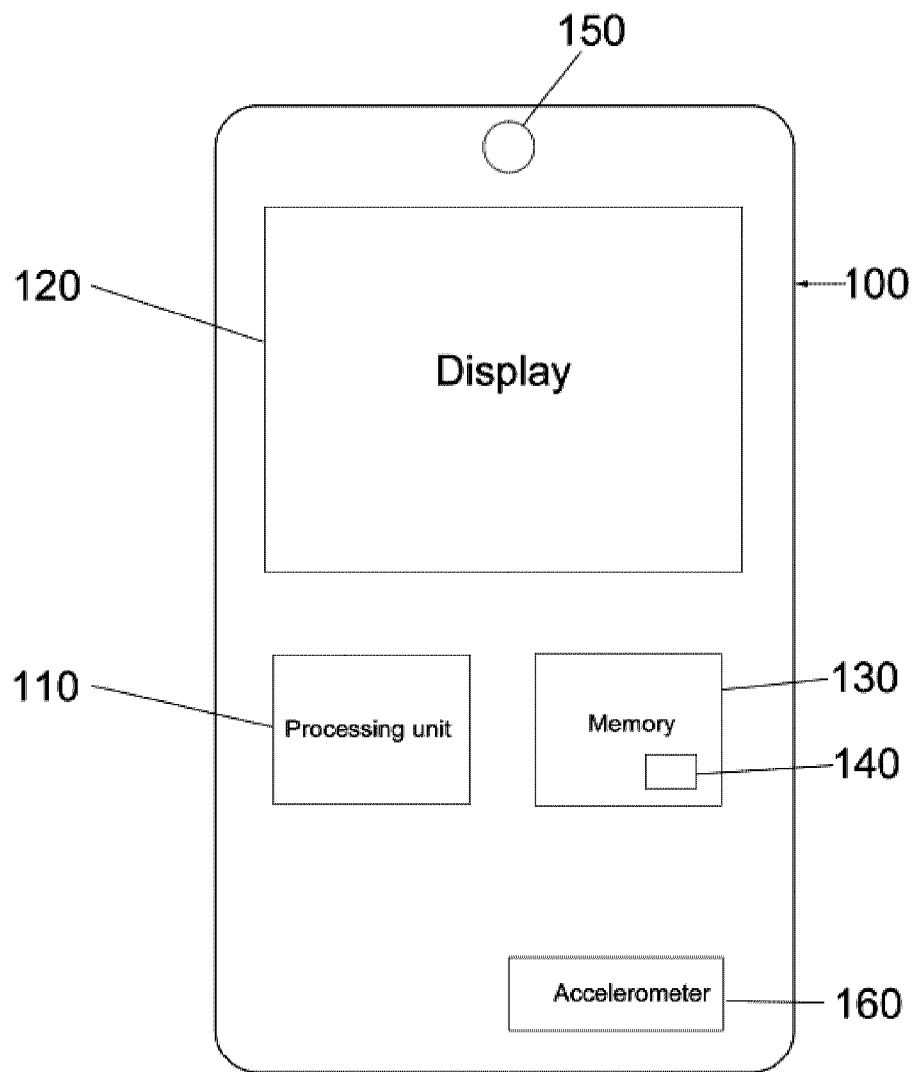

FIGURE 1

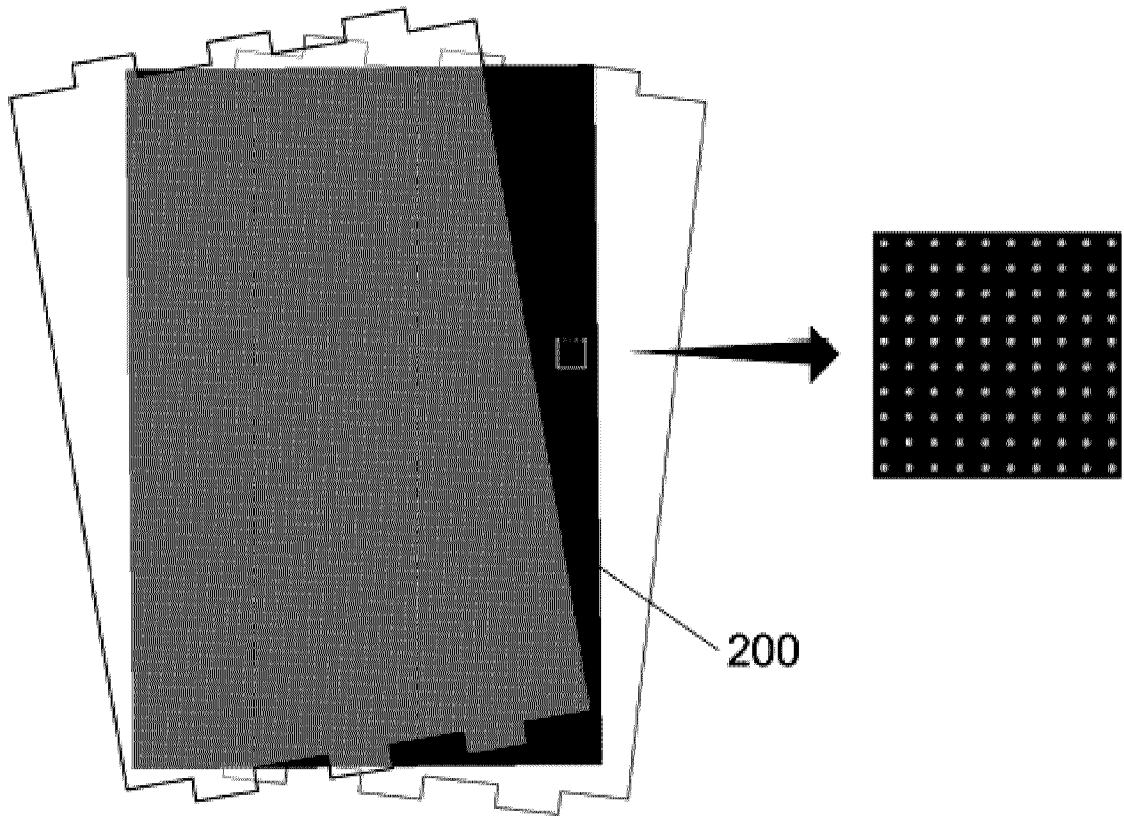
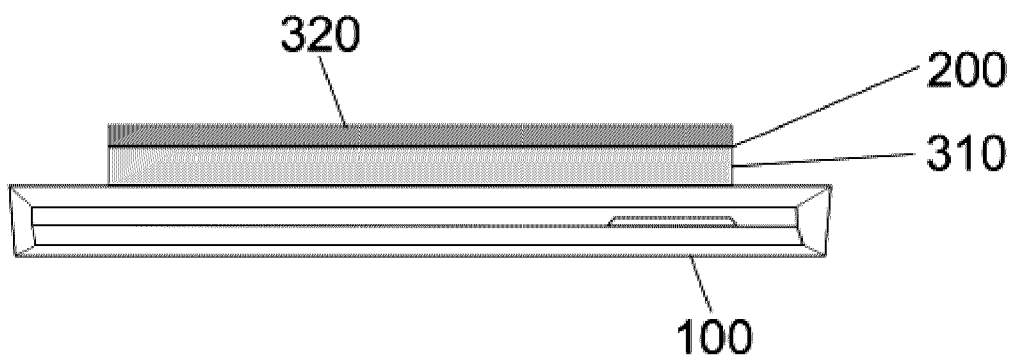
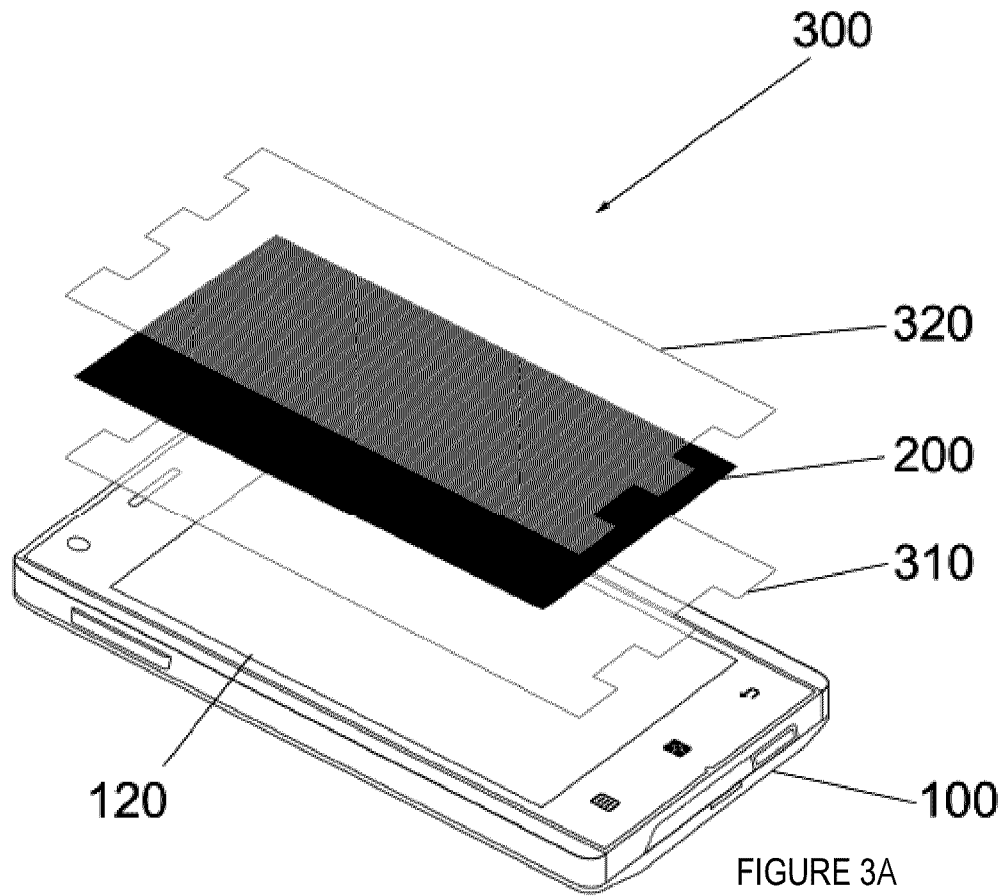

FIGURE 2



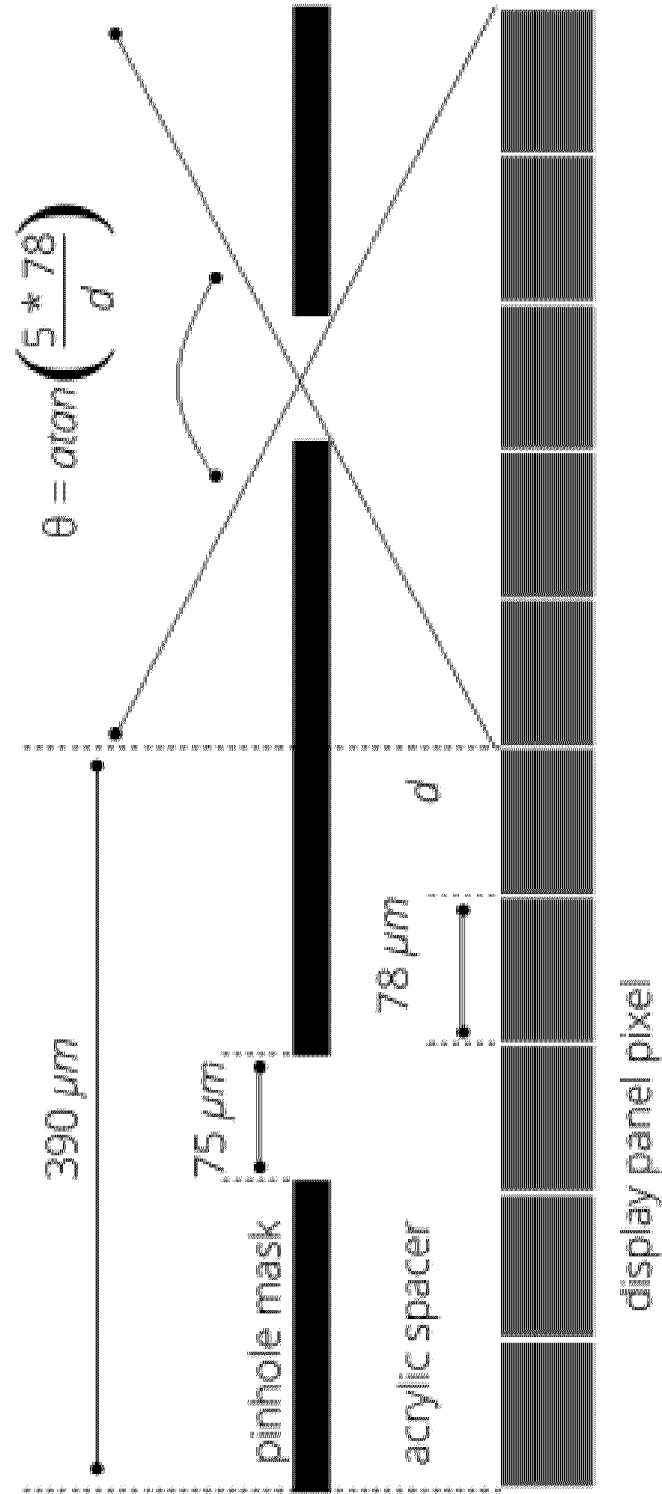

FIGURE 4

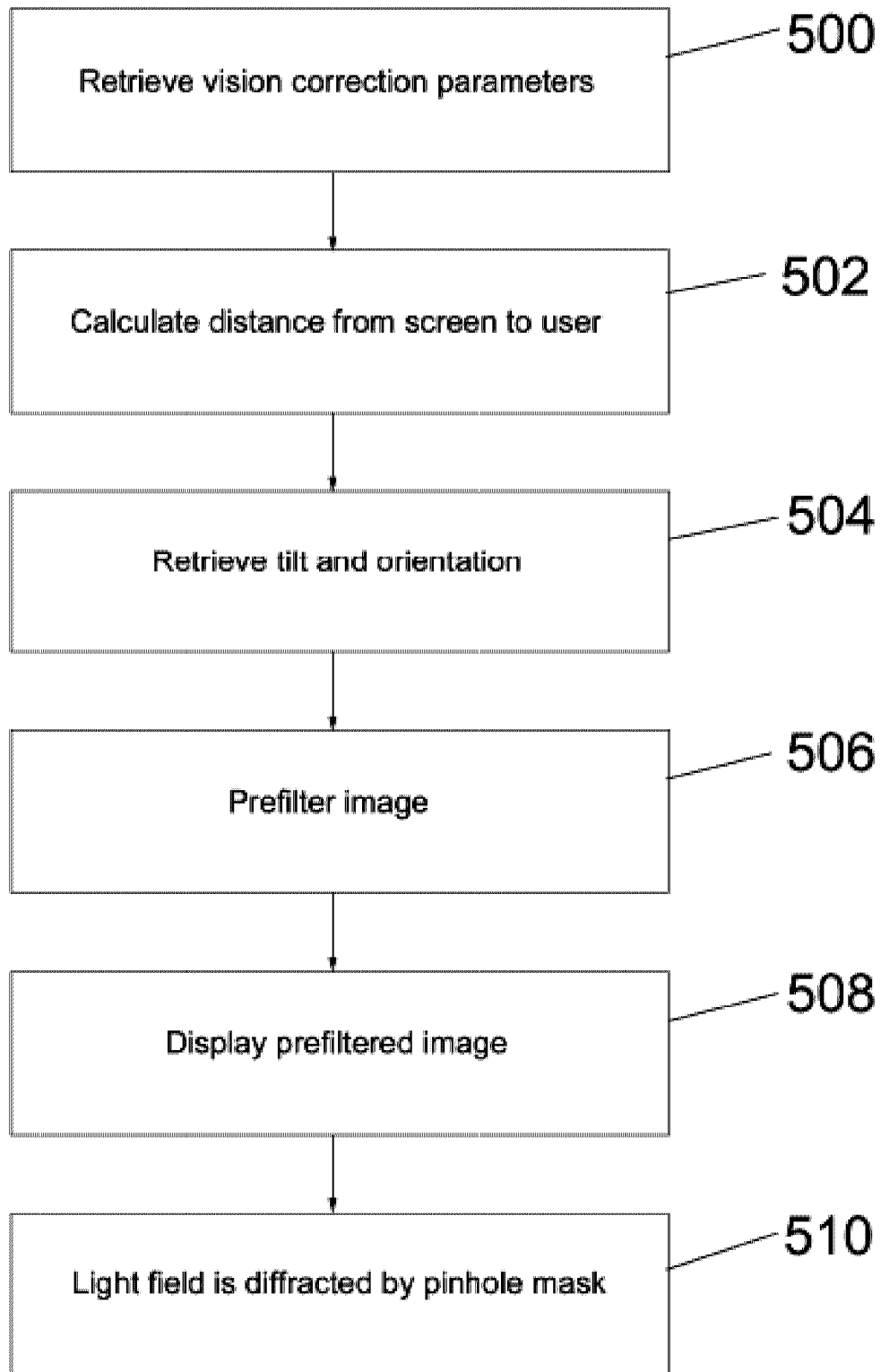

FIGURE 5

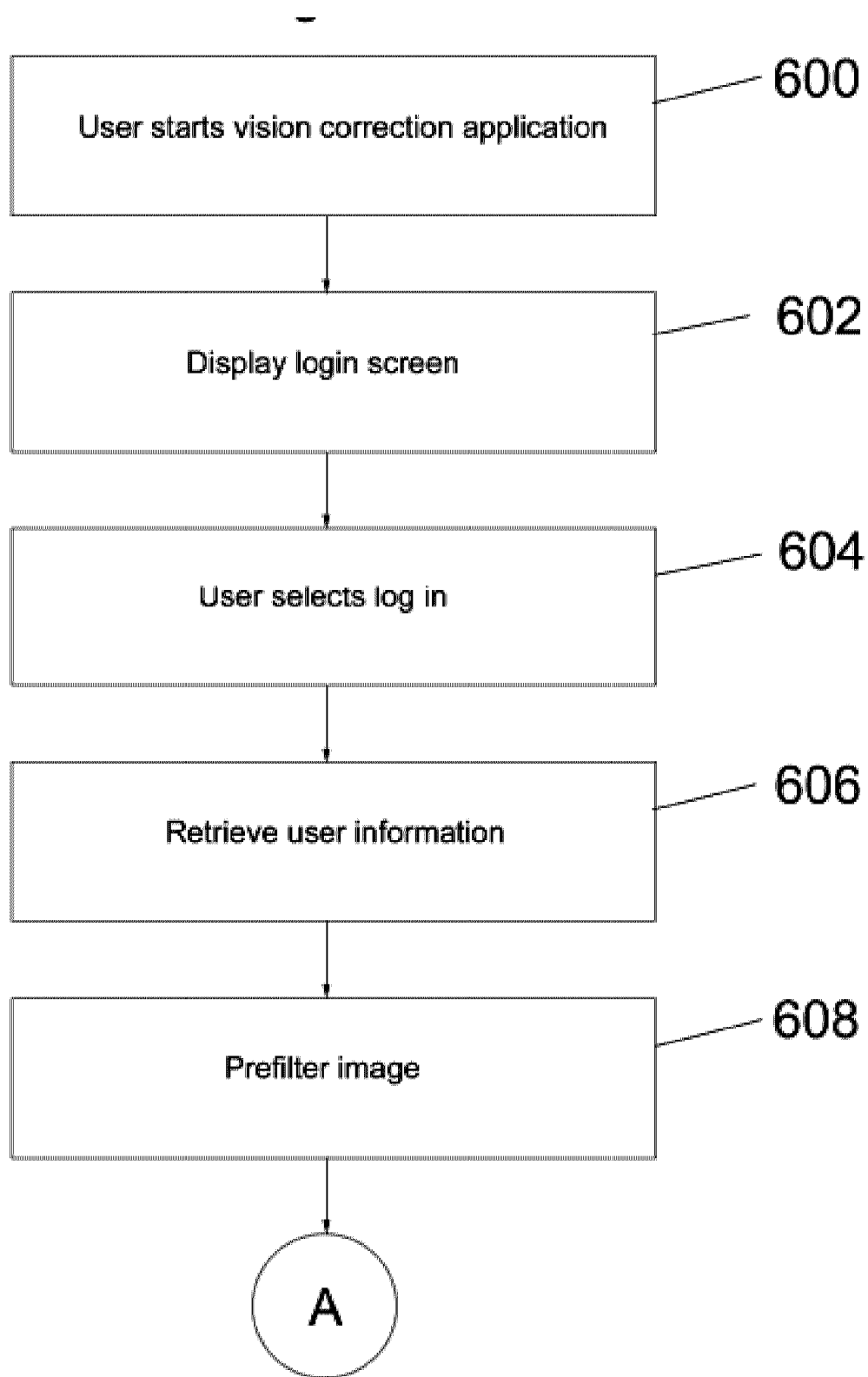

FIGURE 6A

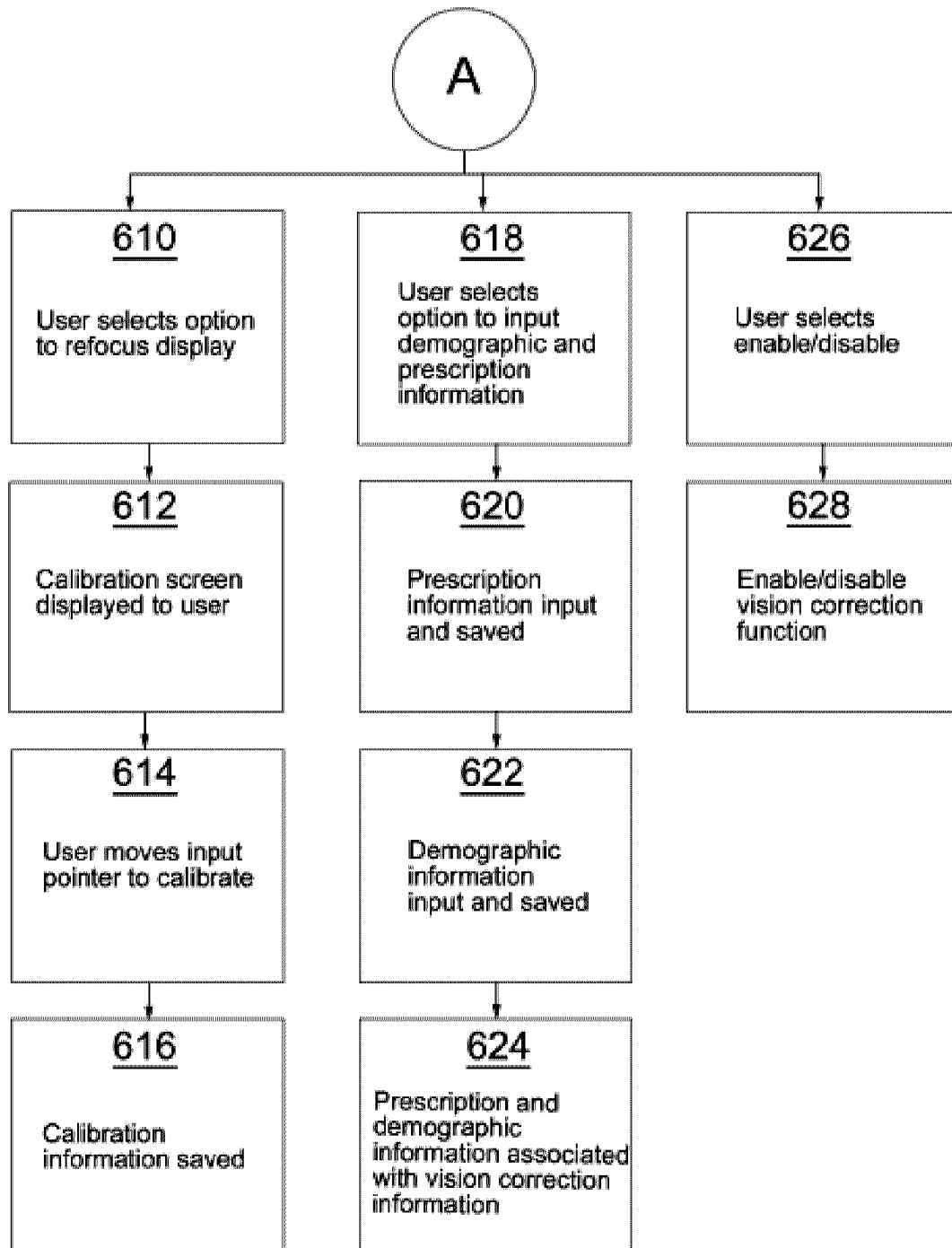

FIGURE 6B

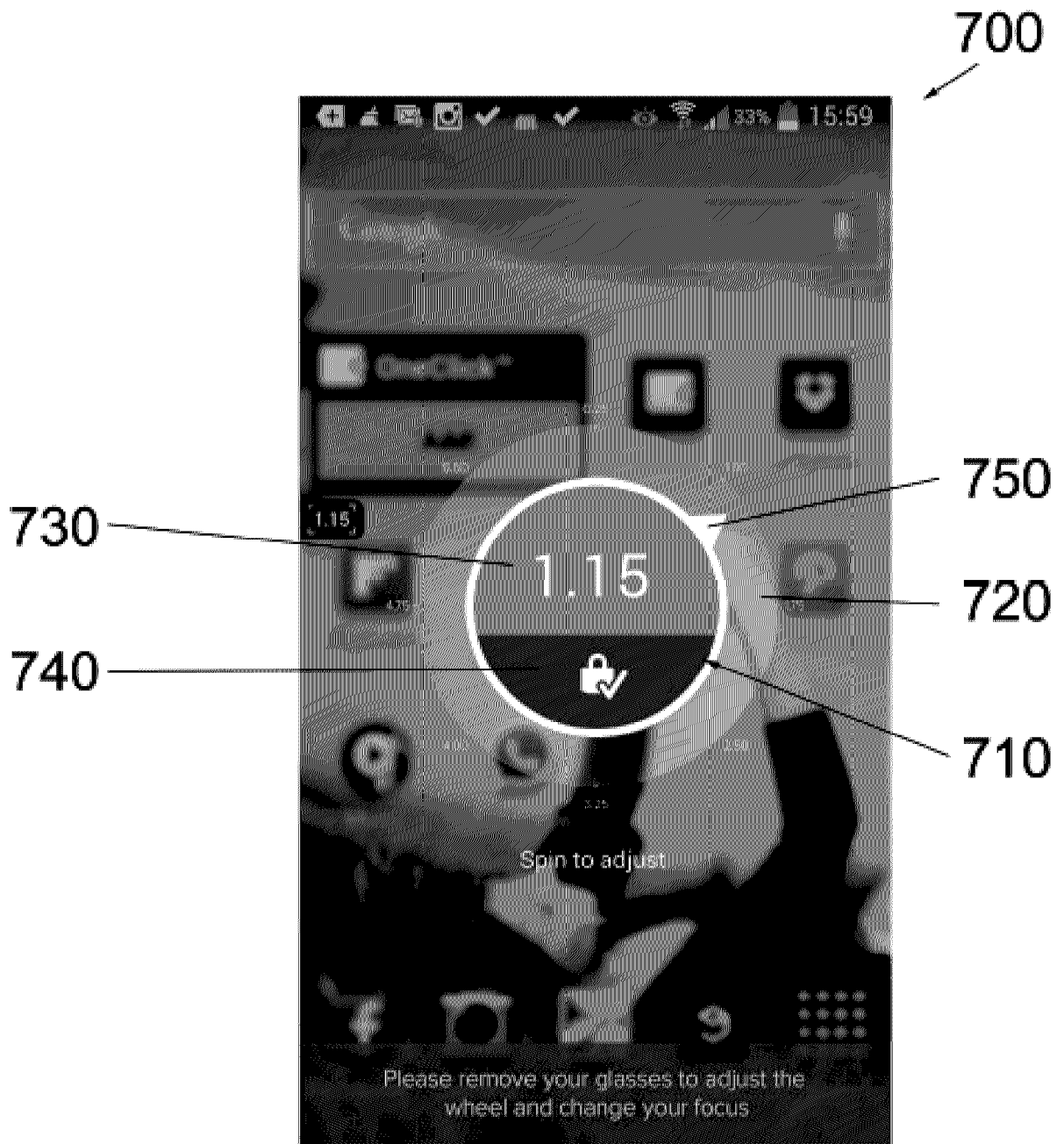

FIGURE 7

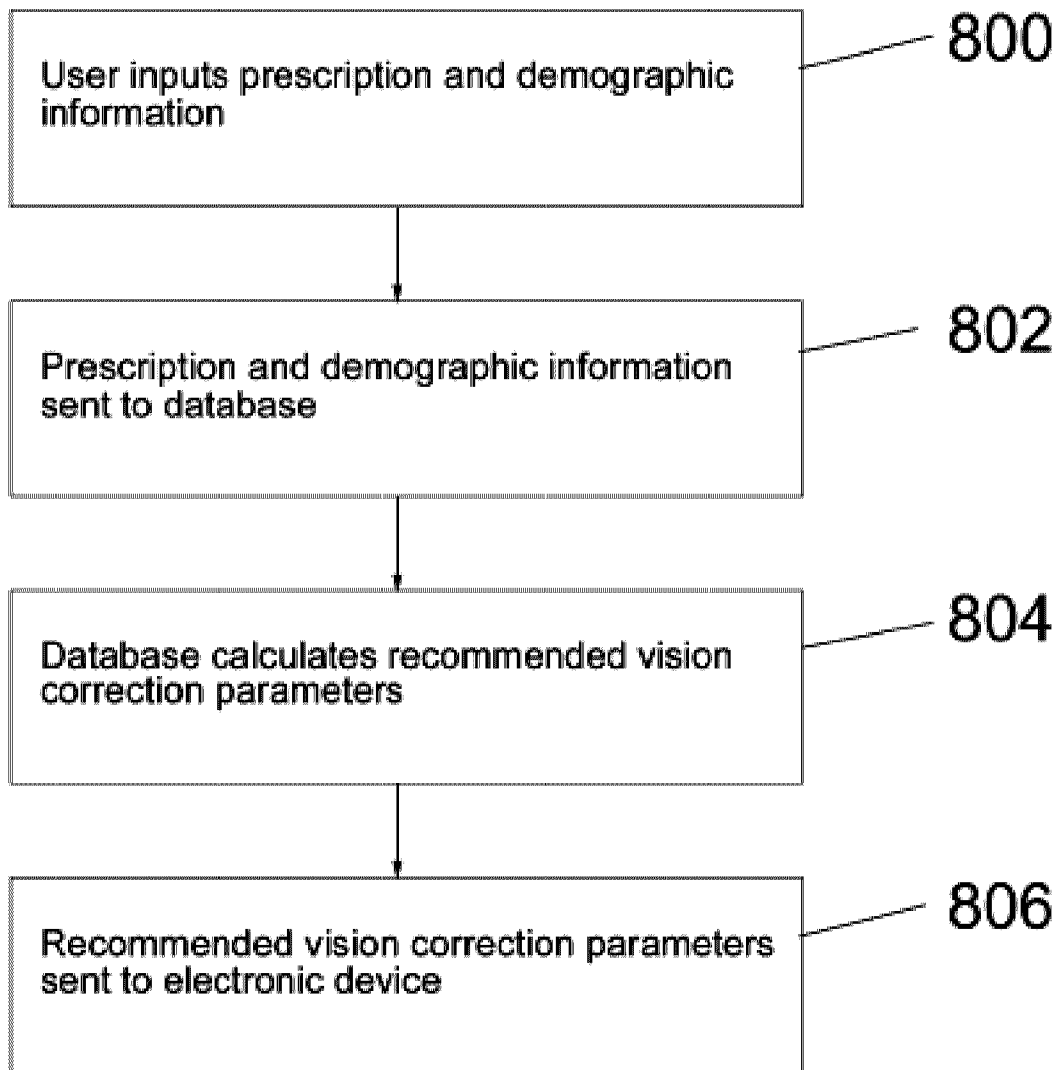
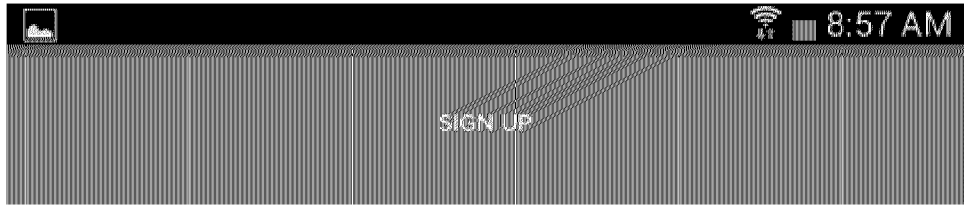

FIGURE 8



FIGURE 9



Please fill the form below

Full Name

Email

Phone Number

Password



Repeat Password

Email Newsletter

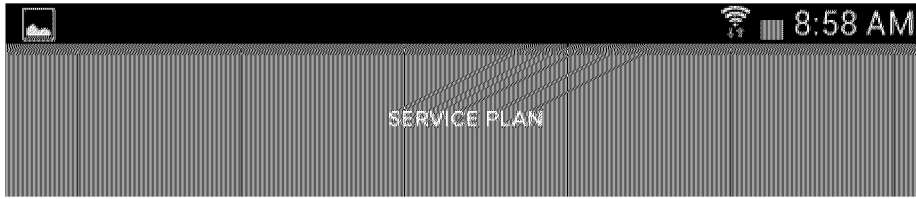
A registration form with five text input fields and one checkbox. The fields are labeled "Full Name", "Email", "Phone Number", "Password", and "Repeat Password". The checkbox is labeled "Email Newsletter" and is checked. The form is enclosed in a dotted-line border.



Choose plan that fit for you

| | | |
|---|--|----------------------------------|
|  | Subscription Based Service Up to 14 days FREE | <input checked="" type="radio"/> |
|  | Annual and Monthly Subscription Options Only \$15/mo | <input type="radio"/> |
|  | Gift Cards and Activation Enter your activation code | <input type="radio"/> |

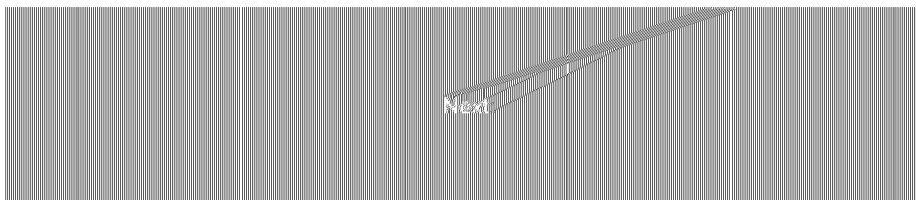

FIGURE 11

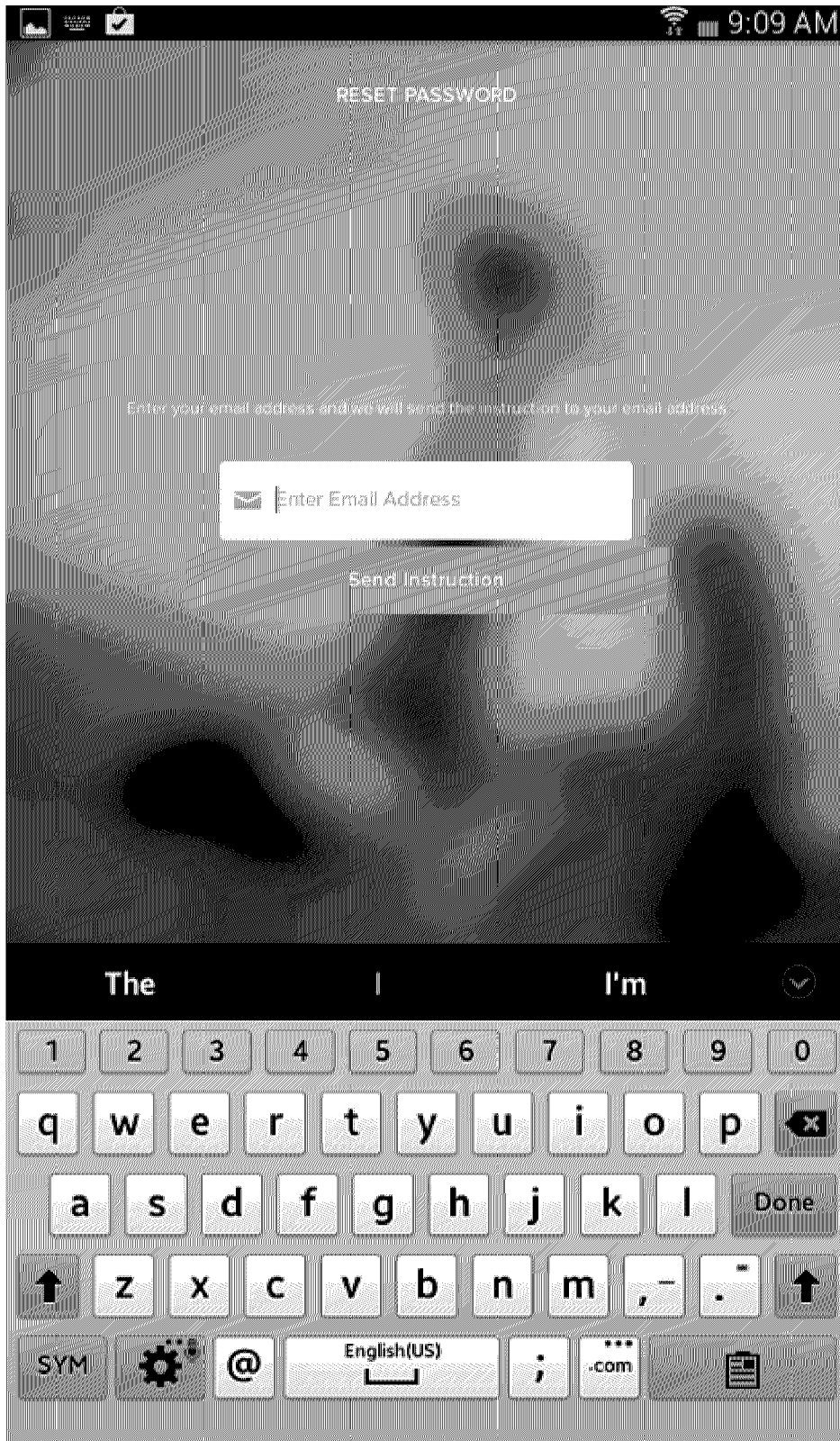

FIGURE 12

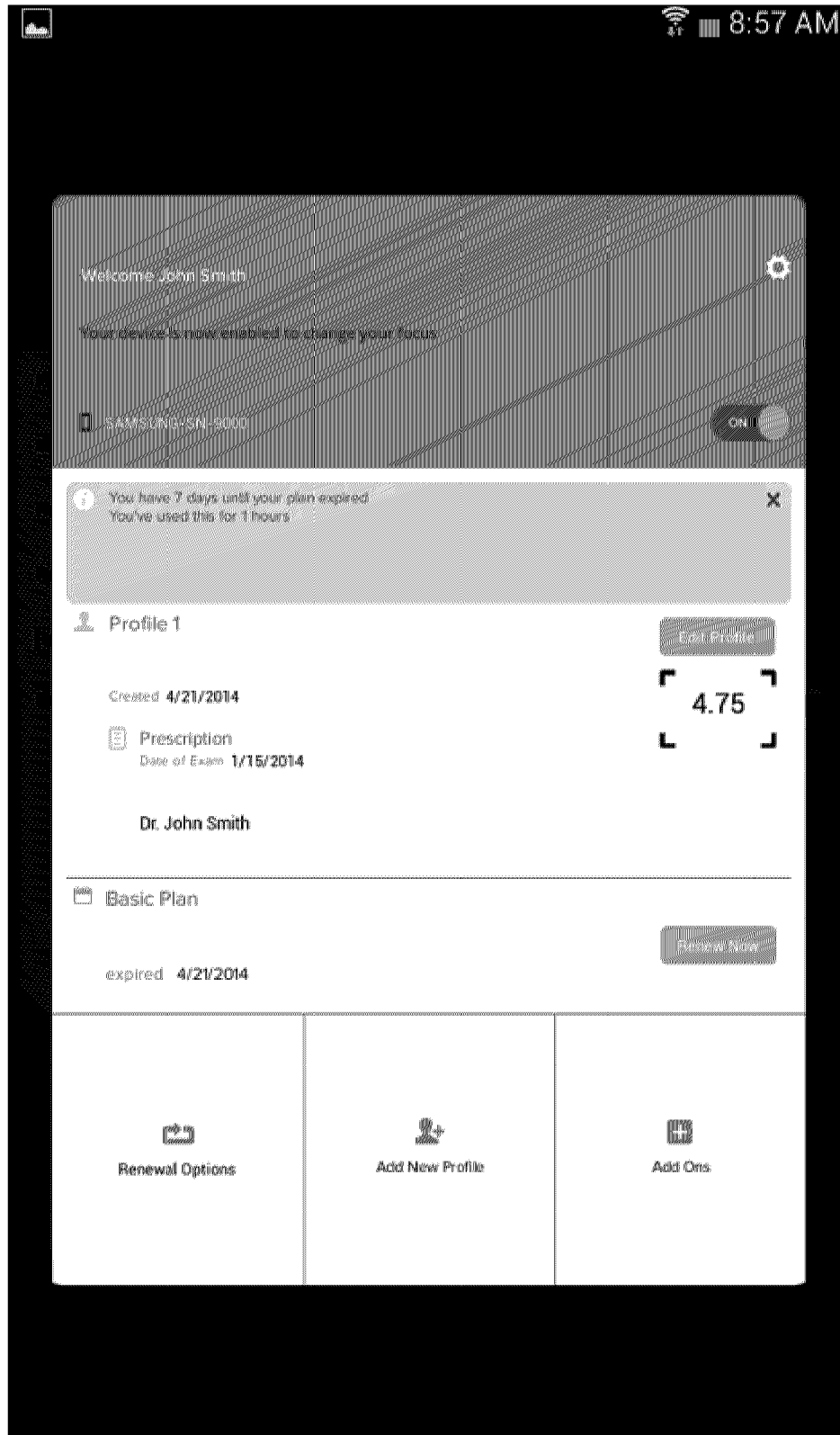

FIGURE 13

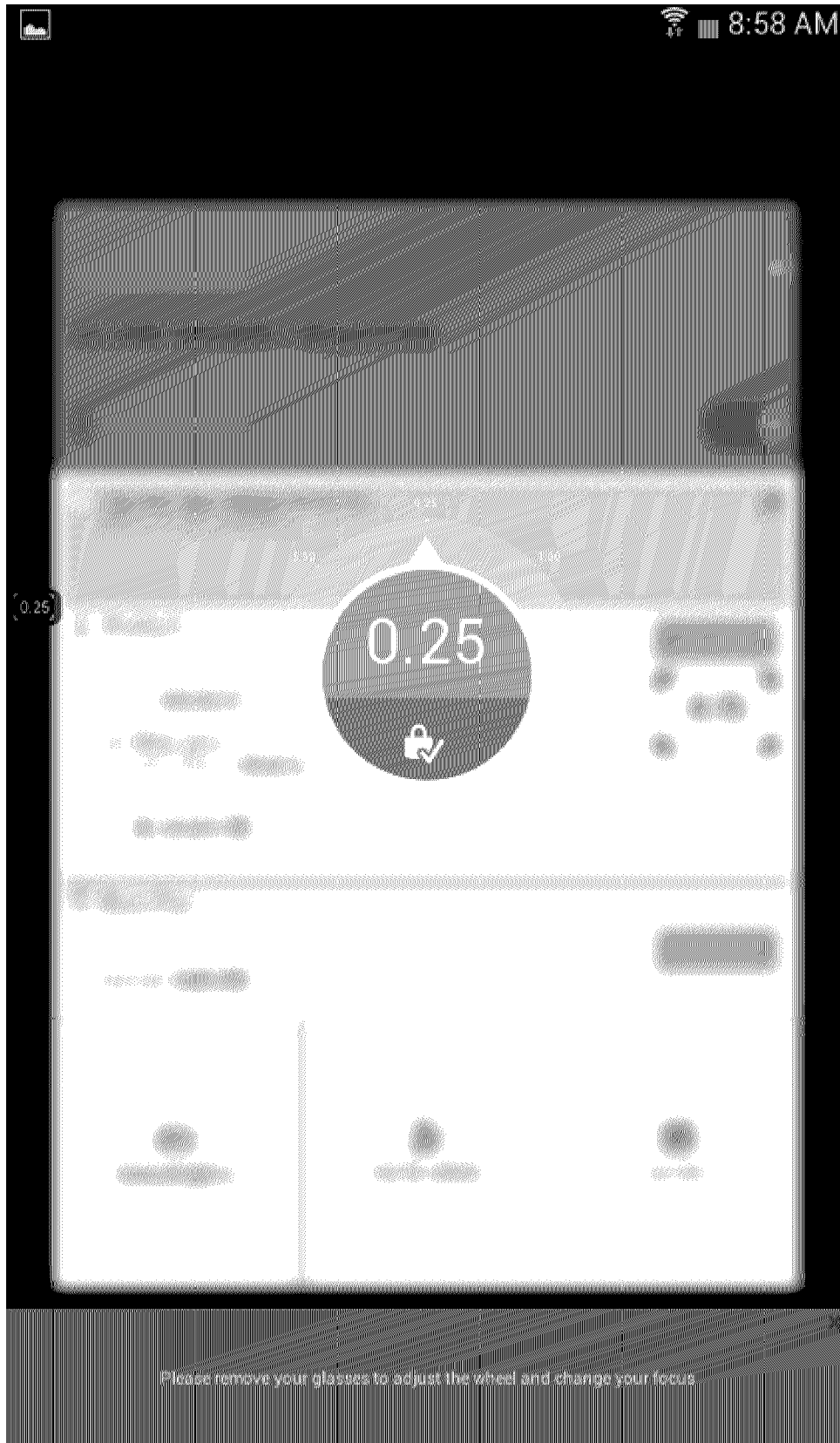

FIGURE 14A

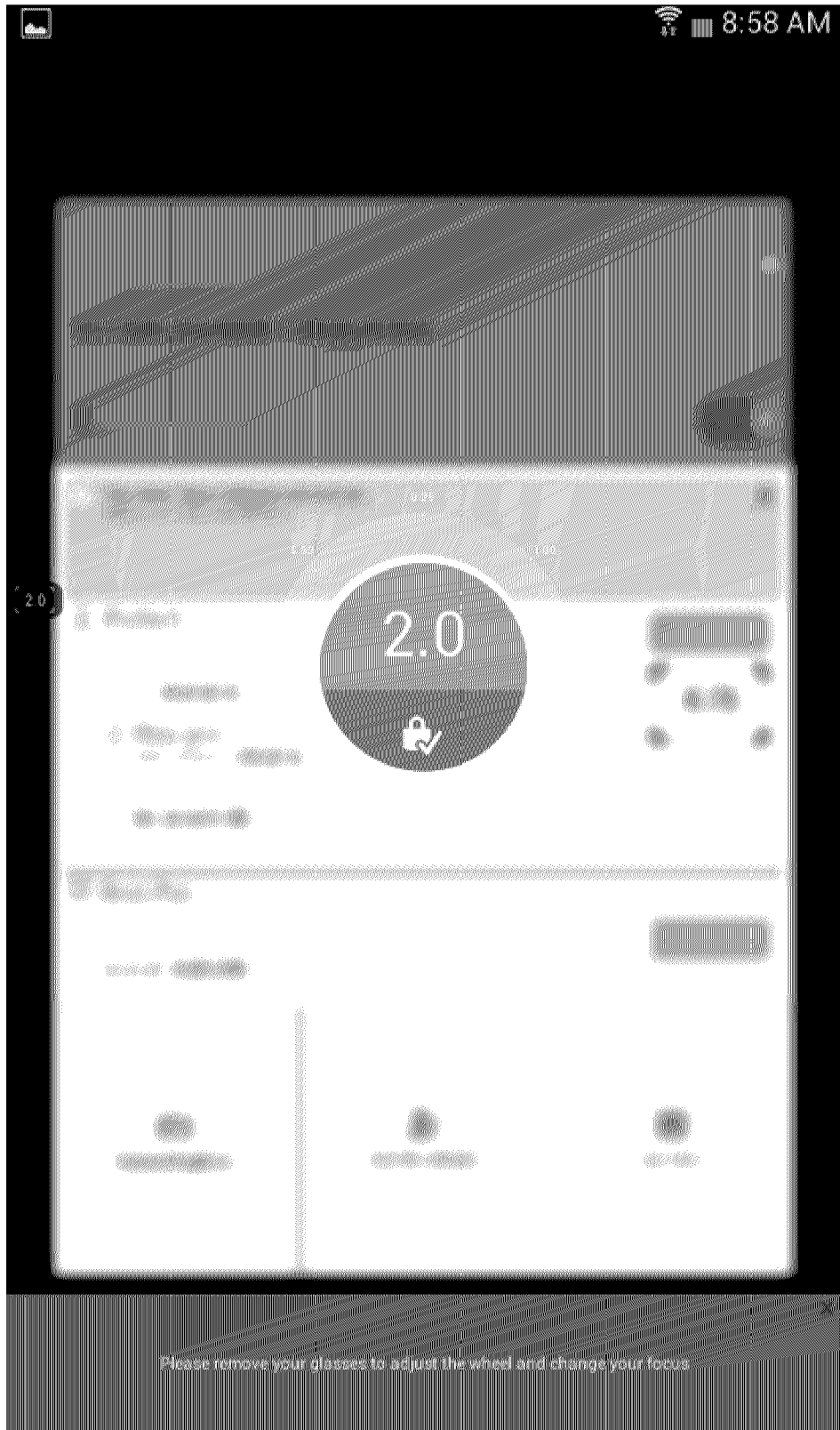

FIGURE 14B

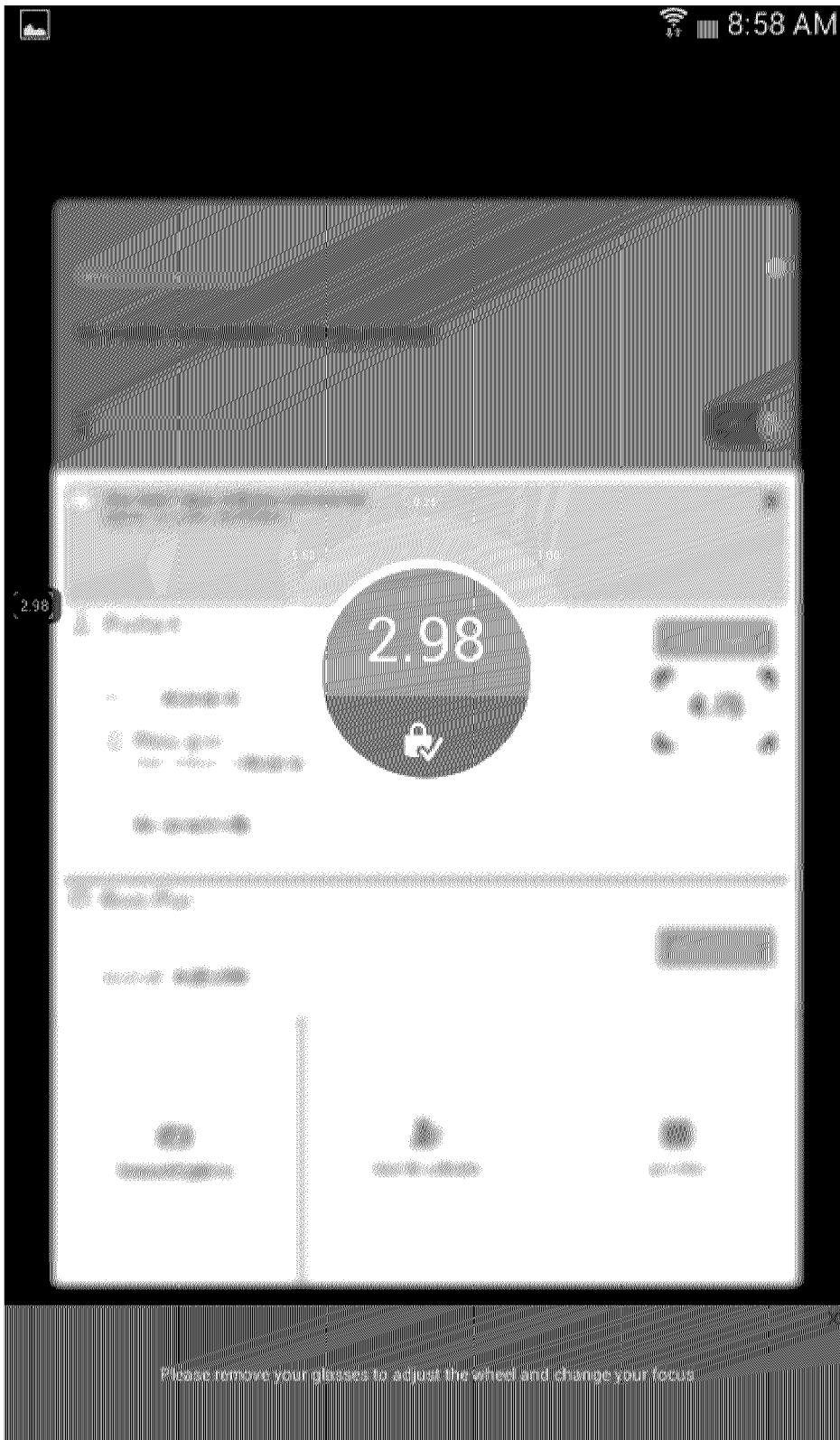

FIGURE 14C



FIGURE 14D

