



(19) **United States**  
 (12) **Reissued Patent**  
**Miloslavsky**

(10) **Patent Number:** **US RE46,528 E**  
 (45) **Date of Reissued Patent:** **Aug. 29, 2017**

- (54) **IMPLEMENTATION OF CALL-CENTER OUTBOUND DIALING CAPABILITY AT A TELEPHONY NETWORK LEVEL**
- (71) Applicant: **Genesys Telecommunications Laboratories, Inc.**, Daly City, CA (US)
- (72) Inventor: **Alec Miloslavsky**, Hillsborough, CA (US)
- (73) Assignee: **GENESYS TELECOMMUNICATIONS LABORATORIES, INC.**, Daly City, CA (US)

- (56) **References Cited**
- U.S. PATENT DOCUMENTS
- |             |         |                 |
|-------------|---------|-----------------|
| 3,914,559 A | 10/1975 | Knollman        |
| 4,048,452 A | 9/1977  | Oehring et al.  |
| 4,056,683 A | 11/1977 | Suehiro         |
| 4,290,141 A | 9/1981  | Anderson et al. |
- (Continued)

FOREIGN PATENT DOCUMENTS

- |    |        |         |
|----|--------|---------|
| AT | 270486 | 7/2004  |
| AT | 281039 | 11/2004 |
- (Continued)

OTHER PUBLICATIONS

"Competitive Gateway Product," Nikkei Communications, Japan, No. 257, Nov. 1997, 18 pages.  
 (Continued)

- (21) Appl. No.: **14/566,612**
- (22) Filed: **Dec. 10, 2014**

**Related U.S. Patent Documents**

- Reissue of:
- (64) Patent No.: **5,991,395**  
 Issued: **Nov. 23, 1999**  
 Appl. No.: **09/095,732**  
 Filed: **Jun. 10, 1998**

- U.S. Applications:
- (63) Continuation-in-part of application No. 08/968,825, filed on Nov. 14, 1997, now Pat. No. 6,005,931.

- (51) **Int. Cl.**  
**H04M 1/00** (2006.01)  
**H04M 3/523** (2006.01)
- (52) **U.S. Cl.**  
 CPC ..... **H04M 3/523** (2013.01)
- (58) **Field of Classification Search**  
 CPC ..... **H04M 3/523**  
 USPC ..... **379/265.02**  
 See application file for complete search history.

*Primary Examiner* — Michelle Tarae  
 (74) *Attorney, Agent, or Firm* — Lewis Roca Rothgerber Christie LLP

- (57) **ABSTRACT**
- A system (33) for outbound dialing for call centers (11) place an outbound dialer (21) at network level (13), and client call centers provide destination number calling lists. The outbound dialer (21), upon completing a call to a destination number, connects the completed call to a routing point at a client call center. The system (33) may be CTI-enhanced, and can be hosted by a client of a network provider, or by the network provider. Clients may subscribe to the network provider for service, providing calling lists and routing points, and completed calls may be routed to call centers operated by different clients. The architecture and method of the system (33) minimizes the number of leased lines required by each call center taking advantage of the system (33).

**13 Claims, 2 Drawing Sheets**

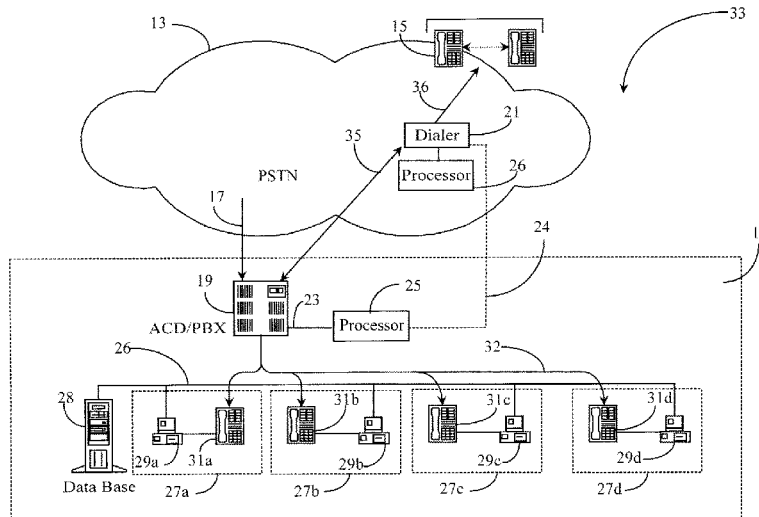

(56)

References Cited

U.S. PATENT DOCUMENTS

4,320,256	A	3/1982	Freeman	5,136,633	A	8/1992	Tejada et al.	
4,345,315	A	8/1982	Cadotte et al.	5,155,761	A	10/1992	Hammond	
4,355,207	A	10/1982	Curtin	5,164,983	A	11/1992	Brown et al.	
4,355,372	A	10/1982	Johnson et al.	5,168,515	A	12/1992	Gechter et al.	
4,400,587	A	8/1983	Taylor et al.	5,175,800	A	12/1992	Galis et al.	
4,439,636	A	3/1984	Newkirk et al.	5,179,589	A	1/1993	Syu .....	379/265
4,451,700	A	5/1984	Kempner et al.	5,181,236	A	1/1993	LaVallee et al.	
4,489,438	A	12/1984	Hughes	5,181,239	A	1/1993	Jolissaint	
4,512,011	A	4/1985	Turner	5,185,782	A	2/1993	Srinivasan	
4,517,410	A	5/1985	Williams et al.	5,202,828	A	4/1993	Vertelney et al.	
4,521,643	A	6/1985	Dupuis et al.	5,206,903	A	4/1993	Kohler et al.	
4,523,055	A	6/1985	Hohl et al.	5,208,745	A	5/1993	Quentin et al.	
4,528,643	A	7/1985	Freeny, Jr.	5,212,727	A	5/1993	Ramkumar	
4,539,435	A	9/1985	Eckmann	5,214,688	A	5/1993	Szlam et al.	
4,555,903	A	12/1985	Heaton	5,231,670	A	7/1993	Goldhor et al.	
4,558,180	A	12/1985	Scordo	5,247,569	A	9/1993	Cave	
4,559,415	A	12/1985	Bernard et al.	5,249,223	A	9/1993	Vanacore	
4,566,030	A	1/1986	Nickerson et al.	5,253,288	A	10/1993	Frey et al.	
4,567,323	A	1/1986	Lottes et al.	5,256,863	A	10/1993	Ferguson et al.	
4,577,062	A	3/1986	Hilleary et al.	5,261,096	A	11/1993	Howarth	
4,577,067	A	3/1986	Levy et al.	5,271,058	A	12/1993	Andrews et al.	
4,578,700	A	3/1986	Roberts et al.	5,274,635	A	12/1993	Rahman et al.	
4,580,012	A	4/1986	Matthews et al.	5,274,700	A	12/1993	Gechter et al.	
4,584,602	A	4/1986	Nakagawa	5,274,782	A	12/1993	Chalasanani et al.	
4,587,379	A	5/1986	Masuda	5,278,898	A	1/1994	Cambray et al.	
4,598,367	A	7/1986	DeFrancesco et al.	5,278,977	A	1/1994	Spencer et al.	
4,603,232	A	7/1986	Kurland et al.	5,280,625	A	1/1994	Howarter et al.	
4,611,094	A	9/1986	Asmuth et al.	5,283,638	A	2/1994	Engberg et al.	
4,625,276	A	11/1986	Benton et al.	5,283,856	A	2/1994	Gross et al.	
4,630,200	A	12/1986	Ohmae et al.	5,285,494	A	2/1994	Sprecher et al.	
4,630,201	A	12/1986	White	5,288,147	A	2/1994	Schaefer et al.	
4,634,809	A	1/1987	Paulsson et al.	5,291,550	A	3/1994	Levy et al.	
4,649,563	A	3/1987	Riskin	5,291,551	A	3/1994	Conn et al.	
4,654,482	A	3/1987	DeAngelis	5,291,552	A	3/1994	Kerrigan et al. ....	379/266
4,667,287	A	5/1987	Allen et al.	5,299,259	A	3/1994	Otto .....	379/221
4,674,044	A	6/1987	Kalmus et al.	5,299,260	A	3/1994	Shaio	
4,679,189	A	7/1987	Olson et al.	5,301,320	A	4/1994	McAtee et al.	
4,696,029	A	9/1987	Cohen	5,309,505	A	5/1994	Szlam et al.	
4,697,282	A	9/1987	Winter et al.	5,311,574	A	5/1994	Livanos	
4,737,983	A	4/1988	Frauenthal et al.	5,311,583	A	5/1994	Friedes et al.	
4,756,020	A	7/1988	Fodale	5,315,709	A	5/1994	Alston, Jr. et al.	
4,757,267	A	7/1988	Riskin	5,327,486	A	7/1994	Wolff et al.	
4,763,191	A	8/1988	Gordon et al.	5,329,583	A	7/1994	Jurgensen et al.	
4,763,317	A	8/1988	Lehman et al.	5,333,266	A	7/1994	Boaz et al.	
4,763,353	A	8/1988	Canale et al.	5,335,268	A	8/1994	Kelly, Jr. et al.	
4,771,425	A	9/1988	Baran et al.	5,335,269	A	8/1994	Steinlicht	
4,785,408	A	11/1988	Britton et al.	5,343,477	A	8/1994	Yamada	
4,788,715	A	11/1988	Lee	5,343,518	A	8/1994	Kneipp .....	H04M 3/36 370/522
4,811,382	A	3/1989	Sleevi	5,355,474	A	10/1994	Thuraisingham et al.	
4,812,843	A	3/1989	Champion, III et al.	5,359,649	A	10/1994	Rosu et al.	
4,829,563	A	5/1989	Crockett et al.	5,363,507	A	11/1994	Nakayama et al.	
4,831,518	A	5/1989	Yu et al.	5,367,329	A	11/1994	Nakagaki et al.	
4,852,001	A	7/1989	Tsushima et al.	5,369,695	A	11/1994	Chakravarti et al.	
4,866,756	A	9/1989	Crane et al.	5,384,766	A	1/1995	Yamato et al.	
4,881,261	A	11/1989	Oliphant et al.	5,384,771	A	1/1995	Isidoro et al.	
4,893,328	A	1/1990	Peacock	5,384,829	A	1/1995	Heileman, Jr. et al.	
4,896,345	A	1/1990	Thorne	5,384,841	A	1/1995	Adams et al.	
4,897,866	A	1/1990	Majmudar et al.	5,392,277	A	2/1995	Bernstein	
4,908,850	A	3/1990	Masson et al.	5,392,328	A	2/1995	Schmidt et al.	
4,924,488	A	5/1990	Kosich	5,392,345	A	2/1995	Otto	
4,943,995	A	7/1990	Daudelin et al.	5,392,400	A	2/1995	Berkowitz et al.	
4,944,038	A	7/1990	Hardy et al.	5,402,474	A	3/1995	Miller et al.	
4,953,204	A	8/1990	Cuschleg, Jr. et al.	5,414,762	A	5/1995	Flisik et al.	
4,972,461	A	11/1990	Brown et al.	5,422,813	A	6/1995	Schuchman et al.	
4,994,985	A	2/1991	Cree et al.	5,425,091	A	6/1995	Josephs	
5,001,710	A	3/1991	Gawrys et al.	5,425,093	A	6/1995	Trefger .....	379/266
5,008,930	A	4/1991	Gawrys et al.	5,426,594	A	6/1995	Wright et al.	
5,017,917	A	5/1991	Fisher et al.	5,428,608	A	6/1995	Freeman et al.	
5,020,095	A	5/1991	Morganstein et al.	5,436,965	A	7/1995	Grossman et al. ....	379/266
5,036,535	A	7/1991	Gechter et al.	5,436,967	A	7/1995	Hanson	
5,058,152	A	10/1991	Solomon et al.	5,440,719	A	8/1995	Hanes et al.	
5,062,103	A	10/1991	Davidson et al.	5,444,767	A	8/1995	Goetcheus et al.	
5,073,890	A	12/1991	Danielsen	5,444,774	A	8/1995	Friedes	
5,095,504	A	3/1992	Nishikawa et al.	5,444,823	A	8/1995	Nguyen	
5,117,225	A	5/1992	Wang	5,450,482	A	9/1995	Chen et al.	
				5,450,483	A	9/1995	Williams	
				5,452,350	A	9/1995	Reynolds et al.	
				5,455,903	A	10/1995	Jolissaint et al.	

(56)

References Cited

U.S. PATENT DOCUMENTS

5,459,780	A	10/1995	Sand	5,608,786	A	3/1997	Gordon
5,463,685	A	10/1995	Gaechter et al.	5,610,910	A	3/1997	Focsaneanu et al.
5,465,286	A	11/1995	Clare et al.	5,617,570	A	4/1997	Russell et al.
5,467,391	A	11/1995	Donaghue, Jr. et al. ....	5,619,183	A	4/1997	Ziegler et al.
5,469,504	A	11/1995	Blaha	5,619,557	A	4/1997	Van Berkum
5,473,680	A	12/1995	Porter	5,619,648	A	4/1997	Canale et al.
5,475,813	A	12/1995	Cieslak et al.	5,621,789	A	4/1997	McCalmont et al.
5,479,487	A	* 12/1995	Hammond ..... H04M 3/51	5,621,790	A	4/1997	Grossman et al. .... 379/266
			379/266.07	5,623,600	A	4/1997	Ji et al.
5,481,616	A	1/1996	Freadman	5,624,265	A	4/1997	Redford et al.
5,488,648	A	1/1996	Womble	5,625,404	A	4/1997	Grady et al.
5,491,783	A	2/1996	Douglas et al.	5,625,676	A	4/1997	Greco et al.
5,493,564	A	2/1996	Mullan	5,625,682	A	4/1997	Gray et al.
5,495,522	A	2/1996	Allen et al.	5,627,764	A	5/1997	Schutzman et al.
5,495,523	A	2/1996	Stent et al. .... 379/265	5,627,884	A	5/1997	Williams et al.
5,496,392	A	3/1996	Sims et al.	5,630,127	A	5/1997	Moore et al.
5,497,317	A	3/1996	Hawkins et al.	5,632,011	A	5/1997	Landfield et al.
5,497,371	A	3/1996	Ellis et al.	5,633,920	A	5/1997	Kikinis et al.
5,497,373	A	3/1996	Hulen et al.	5,633,924	A	5/1997	Kaish et al. .... 379/266
5,500,889	A	3/1996	Baker et al.	5,635,918	A	6/1997	Tett
5,500,891	A	3/1996	Harrington et al.	5,640,445	A	6/1997	David
5,506,898	A	4/1996	Costantini et al.	5,642,411	A	6/1997	Theis
5,509,062	A	4/1996	Carlsen	5,642,477	A	6/1997	de Carmo et al.
5,510,829	A	4/1996	Sugiyama et al.	5,642,511	A	6/1997	Chow et al.
5,511,117	A	4/1996	Zazzera	5,644,720	A	7/1997	Boll et al.
5,517,620	A	5/1996	Hashimoto et al.	5,646,981	A	7/1997	Klein
5,519,773	A	5/1996	Dumas et al.	5,649,105	A	7/1997	Aldred et al.
5,524,047	A	6/1996	Brown et al.	5,652,785	A	7/1997	Richardson, Jr. et al.
5,524,147	A	6/1996	Bean	5,652,789	A	7/1997	Miner et al.
5,526,353	A	6/1996	Henley et al.	5,652,791	A	7/1997	Sunderman et al.
5,528,678	A	6/1996	Kaplan	5,654,961	A	8/1997	Araujo et al.
5,530,740	A	6/1996	Irribarren et al.	5,655,015	A	8/1997	Walsh et al.
5,530,744	A	6/1996	Charalambous et al.	5,657,383	A	8/1997	Gerber et al.
5,533,103	A	7/1996	Peavey et al.	5,659,542	A	8/1997	Bell et al.
5,533,107	A	7/1996	Irwin et al.	5,659,604	A	8/1997	Beckmann
5,533,108	A	7/1996	Harris et al.	5,659,746	A	8/1997	Bankert et al.
5,533,110	A	7/1996	Pinard et al.	5,673,304	A	9/1997	Connor et al.
5,533,115	A	7/1996	Hollenbach et al.	5,673,311	A	9/1997	Andruska et al.
5,535,211	A	7/1996	Yano	5,673,322	A	9/1997	Pepe et al.
5,535,256	A	7/1996	Maloney et al.	5,675,637	A	* 10/1997	Szlam et al. .... H04M 3/51
5,535,323	A	7/1996	Miller et al.				379/114.19
5,537,470	A	7/1996	Lee	5,684,870	A	11/1997	Maloney et al.
5,537,630	A	7/1996	Berry et al.	5,689,229	A	11/1997	Chaco et al.
5,539,811	A	7/1996	Nakamura et al.	5,692,033	A	11/1997	Farris
5,544,220	A	8/1996	Trefzger ..... 379/266	5,696,809	A	12/1997	Voit
5,546,452	A	8/1996	Andrews et al.	5,696,811	A	12/1997	Maloney et al.
5,550,816	A	8/1996	Hardwick et al.	5,701,400	A	12/1997	Amado
5,553,133	A	9/1996	Perkins	5,703,943	A	12/1997	Otto
5,555,299	A	9/1996	Maloney et al.	5,706,453	A	1/1998	Cheng et al.
5,555,426	A	9/1996	Johnson et al.	5,708,702	A	1/1998	De Paul et al.
5,557,667	A	9/1996	Bruno et al.	5,712,901	A	1/1998	Meermans
5,559,868	A	9/1996	Blonder	5,715,306	A	2/1998	Sunderman et al.
5,559,877	A	9/1996	Ash et al.	5,715,307	A	2/1998	Zazzera
5,559,878	A	9/1996	Keys et al.	5,715,432	A	2/1998	Xu et al.
5,561,711	A	10/1996	Muller	5,717,747	A	2/1998	Boyle, III et al.
5,561,841	A	10/1996	Markus	5,721,770	A	2/1998	Kohler
5,563,805	A	10/1996	Arbuckle et al.	5,724,412	A	3/1998	Srinivasan
5,563,937	A	10/1996	Bruno et al.	5,724,418	A	3/1998	Brady
5,566,294	A	10/1996	Kojima et al.	5,726,984	A	3/1998	Kubler et al.
5,570,419	A	10/1996	Cave et al.	5,727,159	A	3/1998	Kikinis
5,570,420	A	10/1996	Bress et al.	5,729,594	A	3/1998	Klingman
5,572,579	A	11/1996	Orriss et al.	5,732,078	A	3/1998	Arango
5,572,643	A	11/1996	Judson	5,734,981	A	3/1998	Kennedy, III et al.
5,577,100	A	11/1996	McGregor et al.	5,737,495	A	4/1998	Adams et al.
5,577,105	A	11/1996	Baum et al.	5,737,595	A	4/1998	Cohen et al.
5,583,862	A	12/1996	Callon	5,737,691	A	4/1998	Wang et al.
5,583,922	A	12/1996	Davis et al.	5,737,726	A	4/1998	Cameron et al.
5,590,188	A	12/1996	Crockett ..... 379/225	5,737,727	A	4/1998	Lehmann et al.
5,592,542	A	1/1997	Honda et al.	5,740,238	A	4/1998	Flockhart et al.
5,592,543	A	1/1997	Smith et al.	5,740,240	A	4/1998	Jolissaint
5,594,791	A	1/1997	Szlam et al.	5,742,668	A	4/1998	Pepe et al.
5,598,532	A	1/1997	Liron	5,742,670	A	4/1998	Bennett
5,604,737	A	2/1997	Iwami et al.	5,742,675	A	4/1998	Kilander et al.
5,606,602	A	2/1997	Johnson et al.	5,742,905	A	4/1998	Pepe et al.
5,608,778	A	3/1997	Partridge, III	5,745,687	A	4/1998	Randell
				5,745,878	A	4/1998	Hashimoto et al.
				5,748,884	A	5/1998	Royce et al.
				5,748,907	A	5/1998	Crane
				5,751,706	A	5/1998	Land et al.

(56)

## References Cited

## U.S. PATENT DOCUMENTS

5,751,707 A	5/1998	Voit et al.	5,838,774 A	11/1998	Weisser, Jr.
5,751,795 A	5/1998	Hassler et al.	5,841,854 A	11/1998	Schumacher et al.
5,752,059 A	5/1998	Holleran et al.	5,842,131 A	11/1998	Yamane
5,752,244 A	5/1998	Rose et al.	5,844,980 A	12/1998	Patel et al.
5,752,246 A	5/1998	Rogers et al.	5,844,982 A	12/1998	Knitl
5,754,111 A	5/1998	Garcia	5,847,484 A	12/1998	Kuyama et al.
5,754,636 A	5/1998	Bayless et al.	5,848,131 A	12/1998	Shaffer et al.
5,754,639 A	5/1998	Flockhart et al.	5,848,143 A	12/1998	Andrews et al.
5,754,655 A	5/1998	Hughes et al.	5,850,433 A	12/1998	Rondeau
5,757,904 A	5/1998	Anderson	5,852,814 A	12/1998	Allen
5,760,823 A	6/1998	Brunson et al.	5,857,184 A	1/1999	Lynch
5,761,289 A	6/1998	Keshav	5,862,134 A	1/1999	Deng
5,764,736 A	6/1998	Shachar et al.	5,862,211 A	1/1999	Roush
5,764,898 A	6/1998	Tsuji et al.	5,862,223 A	1/1999	Walker et al.
5,765,033 A	6/1998	Miloslavsky	5,864,616 A	1/1999	Hartmeier
5,768,360 A	6/1998	Reynolds et al.	5,864,848 A	1/1999	Horvitz et al.
5,768,527 A	6/1998	Zhu et al.	5,867,484 A	2/1999	Shaunfield
5,774,583 A	6/1998	Sasaki et al.	5,867,494 A	2/1999	Krishnaswamy et al.
5,778,060 A	7/1998	Otto	5,867,495 A	2/1999	Elliott et al.
5,778,178 A	7/1998	Arunachalam	5,867,559 A	2/1999	Jorgensen et al.
5,778,377 A	7/1998	Marlin et al.	5,867,562 A	2/1999	Scherer
5,784,438 A	7/1998	Martinez	5,867,822 A	2/1999	Sankar
5,784,451 A	7/1998	Smith, Jr.	5,870,464 A	2/1999	Brewster et al.
5,784,452 A	7/1998	Carney	5,870,549 A	2/1999	Bobo, II
5,787,160 A	7/1998	Chaney et al.	5,872,841 A	2/1999	King et al.
5,787,163 A	7/1998	Taylor et al.	5,872,926 A	2/1999	Levac et al.
5,790,635 A	8/1998	Dezozno	5,873,032 A	2/1999	Cox et al.
5,790,650 A	8/1998	Dunn et al.	5,873,040 A	2/1999	Dunn et al.
5,790,789 A	8/1998	Suarez	5,873,076 A	2/1999	Barr et al.
5,790,798 A	8/1998	Beckett, II et al.	5,878,126 A	3/1999	Velamuri et al.
5,793,857 A	8/1998	Barnes et al.	5,878,130 A	3/1999	Andrews et al.
5,793,861 A	8/1998	Haigh	5,878,230 A	3/1999	Weber et al.
5,794,039 A	8/1998	Guck	5,881,146 A	3/1999	Hamilton
5,796,398 A	8/1998	Zimmer	5,883,891 A	3/1999	Williams et al.
5,796,729 A	8/1998	Greaney et al.	5,884,032 A	3/1999	Bateman et al.
5,796,791 A	8/1998	Polcyn ..... 379/265	5,884,262 A	3/1999	Wise et al.
5,796,813 A	8/1998	Sonnenberg	5,887,173 A	3/1999	Ogawa et al.
5,799,067 A	8/1998	Kikinis et al.	5,889,474 A	3/1999	LaDue
5,799,297 A	8/1998	Goodridge et al.	5,889,774 A	3/1999	Mirashrafi et al.
5,802,163 A	9/1998	Miloslavsky	5,889,799 A	3/1999	Grossman et al. .... 379/266
5,802,253 A	9/1998	Gross et al.	5,889,863 A	3/1999	Weber
5,802,283 A	9/1998	Grady et al.	5,892,764 A	4/1999	Riemann et al.
5,802,314 A	9/1998	Tullis et al.	5,892,822 A	4/1999	Gottlieb et al.
5,802,316 A	9/1998	Ito et al.	5,893,912 A	4/1999	Freund et al.
5,802,493 A	9/1998	Sheflott et al.	5,894,512 A	4/1999	Zenner
5,802,526 A	9/1998	Fawcett et al.	5,896,444 A	4/1999	Perlman et al.
5,805,587 A	9/1998	Norris et al.	5,897,635 A	4/1999	Torres et al.
5,806,061 A	9/1998	Chaudhuri et al.	5,901,138 A	5/1999	Bader et al.
5,809,128 A	9/1998	McMullin	5,901,203 A	5/1999	Morganstein et al.
5,809,282 A	9/1998	Cooper et al.	5,901,209 A	5/1999	Tannenbaum et al.
5,809,512 A	9/1998	Kato	5,903,631 A	5/1999	Smith et al.
5,812,795 A	9/1998	Horovitz et al.	5,903,877 A	5/1999	Berkowitz et al.
5,813,014 A	9/1998	Gustman	5,905,495 A	5/1999	Tanaka et al.
5,815,566 A	9/1998	Ramot et al.	5,905,792 A	5/1999	Miloslavsky
5,818,935 A	10/1998	Maa	5,905,793 A	5/1999	Flockhart et al.
5,822,306 A	10/1998	Catchpole	5,905,863 A	5/1999	Knowles et al.
5,822,400 A	10/1998	Smith	5,907,547 A	5/1999	Foladare et al.
5,822,404 A	10/1998	Cave	5,911,134 A	6/1999	Castonguay et al.
5,822,526 A	10/1998	Waskiewicz	5,911,776 A	6/1999	Guck
5,825,775 A	10/1998	Chin et al.	5,914,941 A	6/1999	Janky
5,825,862 A	10/1998	Voit et al.	5,915,001 A	6/1999	Uppaluru
5,825,869 A	10/1998	Brooks et al.	5,915,008 A	6/1999	Dulman
5,825,870 A	10/1998	Miloslavsky	5,915,011 A	6/1999	Miloslavsky
5,826,040 A	10/1998	Fargher et al.	5,915,012 A	6/1999	Miloslavsky
5,826,269 A	10/1998	Hussey	5,916,302 A	6/1999	Dunn et al.
5,828,747 A	10/1998	Fisher et al.	5,917,817 A	6/1999	Dunn et al.
5,828,839 A	10/1998	Moncreiff	5,917,898 A	6/1999	Bassa et al.
5,831,611 A	11/1998	Kennedy et al.	5,918,213 A	6/1999	Bernard et al.
5,832,196 A	11/1998	Croslin et al.	5,920,621 A	7/1999	Gottlieb
5,835,090 A	11/1998	Clark et al.	5,920,719 A	7/1999	Sutton et al.
5,835,570 A	11/1998	Wattenbarger	5,920,865 A	7/1999	Ariga
5,835,583 A	11/1998	Hetz et al.	5,923,745 A	7/1999	Hurd
5,838,682 A	11/1998	Dekelbaum et al.	5,923,879 A	7/1999	Sasmazel et al.
5,838,768 A	11/1998	Sumar et al.	5,926,535 A	7/1999	Reynolds
5,838,773 A	11/1998	Eisner et al.	5,926,538 A	7/1999	Deryugin et al.
			5,926,539 A	7/1999	Shtivelman
			5,933,492 A	8/1999	Turovski
			5,937,051 A	8/1999	Hurd et al.
			5,937,057 A	8/1999	Bell et al.

(56)

## References Cited

## U.S. PATENT DOCUMENTS

5,937,162	A	8/1999	Funk et al.	6,009,163	A	12/1999	Nabkel et al.
5,937,388	A	8/1999	Davis et al.	6,009,469	A	12/1999	Mattaway et al.
5,938,725	A	8/1999	Hara	6,011,792	A	1/2000	Miloslavsky
5,940,075	A	8/1999	Mutschler, III et al.	6,011,844	A	1/2000	Uppaluru et al.
5,940,478	A	8/1999	Vaudreuil et al.	6,011,974	A	1/2000	Cedervall et al.
5,940,479	A	8/1999	Guy et al.	6,012,152	A	1/2000	Douik et al.
5,940,488	A	8/1999	DeGrazia et al.	6,014,137	A	1/2000	Burns
5,940,495	A	8/1999	Bondarenko et al.	6,014,138	A	1/2000	Cain et al.
5,940,496	A	8/1999	Gisby et al.	6,014,379	A	1/2000	White et al.
5,940,497	A	8/1999	Miloslavsky	6,014,437	A	1/2000	Acker et al.
5,940,598	A	8/1999	Strauss et al.	6,014,647	A	1/2000	Nizzari et al.
5,940,823	A	8/1999	Schreiber et al.	6,014,711	A	1/2000	Brown
5,943,416	A	8/1999	Gisby	6,018,578	A	1/2000	Bondarenko et al.
5,946,375	A	8/1999	Pattison et al.	6,018,579	A	1/2000	Petrunka
5,946,386	A	8/1999	Rogers et al.	6,018,761	A	1/2000	Uomini
5,946,387	A	8/1999	Miloslavsky	6,021,262	A	2/2000	Cote et al.
5,946,388	A	8/1999	Walker et al.	6,021,411	A	2/2000	Brophy et al.
5,948,054	A	9/1999	Nielsen	6,021,428	A	2/2000	Miloslavsky
5,949,988	A	9/1999	Feisullin et al.	6,023,684	A	2/2000	Pearson
5,953,332	A	9/1999	Miloslavsky	6,023,723	A	2/2000	McCormick et al.
5,953,405	A	9/1999	Miloslavsky	6,026,087	A	2/2000	Mirashrafi et al.
5,953,406	A	9/1999	LaRue et al.	6,026,375	A	2/2000	Hall et al.
5,956,482	A	9/1999	Agraharam et al.	6,028,917	A	2/2000	Creamer et al.
5,956,729	A	9/1999	Goetz et al.	6,029,195	A	2/2000	Herz
5,958,014	A	9/1999	Cave	6,038,293	A	3/2000	McNerney et al.
5,958,016	A	9/1999	Chang et al.	6,038,537	A	3/2000	Matsuoka
5,958,064	A	9/1999	Judd et al.	6,041,116	A	3/2000	Meyers
5,959,982	A	9/1999	Federkins et al.	6,044,142	A	3/2000	Hammarstrom et al.
5,960,073	A	9/1999	Kikinis et al.	6,044,144	A	3/2000	Becker et al.
5,960,411	A	9/1999	Hartman et al.	6,044,146	A	3/2000	Gisby et al.
5,963,632	A	10/1999	Miloslavsky	6,044,368	A	3/2000	Powers
5,963,635	A	10/1999	Szlam et al.	6,046,762	A	4/2000	Sonesh et al.
5,966,427	A	10/1999	Shaffer et al.	6,047,060	A	4/2000	Fedorov et al.
5,966,695	A	10/1999	Melchione et al.	6,049,272	A	4/2000	Lee et al.
5,970,065	A	10/1999	Miloslavsky	6,049,547	A	4/2000	Fisher et al.
5,970,134	A	10/1999	Highland et al.	6,049,779	A	4/2000	Berkson
5,974,135	A	10/1999	Breneman et al.	6,052,514	A	4/2000	Gill et al.
5,974,414	A	10/1999	Stanczak et al.	6,055,307	A	4/2000	Behnke et al.
5,974,444	A	10/1999	Konrad	6,055,308	A	4/2000	Miloslavsky et al.
5,974,448	A	10/1999	Yamauchi et al.	6,055,513	A	4/2000	Katz et al.
RE36,416	E	11/1999	Szlam et al.	6,058,163	A	5/2000	Pattison et al.
5,978,465	A	11/1999	Corduoy et al.	6,058,389	A	5/2000	Chandra et al.
5,978,467	A	11/1999	Walker et al.	6,058,435	A	5/2000	Sassin et al.
5,978,672	A	11/1999	Hartmaier et al.	6,061,054	A	5/2000	Jolly
5,978,836	A	11/1999	Ouchi	6,064,667	A	5/2000	Gisby et al.
5,982,774	A	11/1999	Foladare et al.	6,064,722	A	5/2000	Clise et al.
5,982,870	A	11/1999	Pershan et al.	6,064,723	A	5/2000	Cohn et al.
5,982,873	A	11/1999	Flockhart et al.	6,064,730	A	5/2000	Ginsberg
5,983,218	A	11/1999	Syeda-Mahmood	6,064,973	A	5/2000	Smith et al.
5,987,102	A	11/1999	Elliott et al.	6,067,357	A	5/2000	Kishinsky et al.
5,987,117	A	11/1999	McNeil et al.	6,069,890	A	5/2000	White et al.
5,987,118	A	11/1999	Dickerman et al.	6,070,142	A	5/2000	McDonough et al.
5,987,423	A	11/1999	Arnold et al.	6,070,144	A	5/2000	Ginsberg et al.
5,987,446	A	11/1999	Corey et al.	6,072,864	A	6/2000	Shtivelman et al.
5,991,365	A	11/1999	Pizano et al.	6,073,013	A	6/2000	Agre et al.
5,991,390	A	11/1999	Booton	6,073,105	A	6/2000	Sutcliffe et al.
5,991,391	A	11/1999	Miloslavsky	6,073,109	A	6/2000	Flores et al.
5,991,392	A	11/1999	Miloslavsky	6,073,124	A	6/2000	Krishnan et al.
5,991,393	A	11/1999	Kamen	6,075,783	A	6/2000	Voit
5,991,394	A	11/1999	Dezonno et al.	6,075,843	A	6/2000	Cave
5,991,395	A	11/1999	Miloslavsky	6,076,101	A	6/2000	Kamakura et al.
5,995,606	A	11/1999	Civanlar et al.	6,076,105	A	6/2000	Wolff et al.
5,995,610	A	11/1999	Smidt et al.	6,076,109	A	6/2000	Kikinis
5,995,614	A	11/1999	Miloslavsky	6,078,581	A	6/2000	Shtivelman et al.
5,995,615	A	11/1999	Miloslavsky	6,078,583	A	6/2000	Takahara et al.
5,996,000	A	11/1999	Shuster	6,081,591	A	6/2000	Skoog
5,999,525	A	12/1999	Krishnaswamy et al.	6,081,592	A	6/2000	Battle
5,999,609	A	12/1999	Nishimura	6,085,097	A	7/2000	Savery et al.
5,999,965	A	12/1999	Kelly	6,085,201	A	7/2000	Tso
6,002,396	A	12/1999	Davies	6,088,340	A	7/2000	Buchholz et al.
6,002,760	A	12/1999	Gisby	6,088,696	A	7/2000	Moon et al.
6,003,034	A	12/1999	Tuli	6,088,717	A	7/2000	Reed et al.
6,005,845	A	12/1999	Svennesson et al.	6,094,479	A	7/2000	Lindeberg et al.
6,005,920	A	12/1999	Fuller et al.	6,094,673	A	7/2000	Dilip et al.
6,005,931	A	12/1999	Neyman et al.	6,097,792	A	8/2000	Thornton
				6,097,804	A	8/2000	Gilbert et al.
				6,097,938	A	8/2000	Paxson
				6,098,065	A	8/2000	Skillen et al.
				6,101,473	A	8/2000	Scott et al.

(56)

## References Cited

## U.S. PATENT DOCUMENTS

6,104,711	A	8/2000	Voit	6,219,413	B1	4/2001	Burg
6,104,800	A	8/2000	Benson	6,222,919	B1	4/2001	Hollatz et al.
6,104,801	A	8/2000	Miloslavsky	6,226,285	B1	5/2001	Kozdon et al.
6,104,802	A	8/2000	Perlmutter	6,229,524	B1	5/2001	Chernock et al.
6,108,688	A	8/2000	Nielsen	6,229,888	B1	5/2001	Miloslavsky
6,108,704	A	8/2000	Hutton et al.	6,230,197	B1	5/2001	Beck et al.
6,108,711	A	8/2000	Beck et al.	6,233,234	B1	5/2001	Curry et al.
6,112,085	A	8/2000	Garner et al.	6,233,616	B1	5/2001	Reid
6,115,596	A	9/2000	Raith et al.	6,236,857	B1	5/2001	Calabrese et al.
6,115,742	A	9/2000	Franklin et al.	6,240,285	B1	5/2001	Blum et al.
6,118,865	A	9/2000	Gisby	6,243,092	B1	6/2001	Okita et al.
6,119,155	A	9/2000	Rossmann et al.	6,243,373	B1	6/2001	Turock
6,119,167	A	9/2000	Boyle et al.	6,243,375	B1	6/2001	Speicher
6,122,360	A	9/2000	Neyman et al.	6,243,379	B1	6/2001	Veerina et al.
6,122,364	A	9/2000	Petrunka et al.	6,243,713	B1	6/2001	Nelson et al.
6,122,365	A	9/2000	Yegoshin	6,249,807	B1	6/2001	Shaw et al.
6,122,632	A	9/2000	Botts et al.	6,253,129	B1	6/2001	Jenkins et al.
6,125,113	A	9/2000	Farris et al.	6,256,489	B1	7/2001	Lichter et al.
6,125,126	A	9/2000	Hallenstål	6,256,503	B1	7/2001	Stephens
6,128,379	A	10/2000	Smyk	6,259,692	B1	7/2001	Shtivelman et al.
6,128,482	A	10/2000	Nixon et al.	6,259,774	B1	7/2001	Miloslavsky
6,128,603	A	10/2000	Dent et al.	6,259,786	B1	7/2001	Gisby
6,128,646	A	10/2000	Miloslavsky	6,263,049	B1	7/2001	Kuhn
6,130,933	A	10/2000	Miloslavsky	6,263,065	B1	7/2001	Durinovic-Johri et al.
6,134,217	A	10/2000	Stiliadis et al.	6,263,066	B1	7/2001	Shtivelman et al.
6,134,235	A	10/2000	Goldman et al.	6,263,359	B1	7/2001	Fong et al.
6,134,315	A	10/2000	Galvin	6,275,693	B1	8/2001	Lin et al.
6,134,318	A	10/2000	O'Neil	6,278,976	B1	8/2001	Kochian
6,134,530	A	10/2000	Bunting et al.	6,278,996	B1	8/2001	Richardson et al.
6,137,870	A	10/2000	Scherer	6,282,429	B1	8/2001	Baiyor et al.
6,138,139	A	10/2000	Beck et al.	6,282,565	B1	8/2001	Shaw et al.
6,141,345	A	10/2000	Goeddel et al.	6,285,316	B1	9/2001	Nir et al.
6,148,074	A	11/2000	Miloslavsky et al.	6,285,364	B1	9/2001	Giordano, III et al.
6,157,653	A	12/2000	Kline et al.	6,286,033	B1	9/2001	Kishinsky et al.
6,157,655	A	12/2000	Shtivelman	6,286,084	B1	9/2001	Wexler et al.
6,157,924	A	12/2000	Austin	6,286,129	B1	9/2001	Agarwal et al.
6,166,735	A	12/2000	Dom et al.	6,289,094	B1	9/2001	Miloslavsky
6,167,255	A	12/2000	Kennedy, III et al.	6,292,181	B1	9/2001	Banerjee et al.
6,167,395	A	12/2000	Beck et al.	6,292,553	B1	9/2001	Fellingham et al.
6,167,404	A	12/2000	Morcos et al.	6,295,353	B1	9/2001	Flockhart et al.
6,170,011	B1	1/2001	Macleod Beck et al.	6,295,530	B1	9/2001	Ritchie et al.
6,173,052	B1	1/2001	Brady	6,298,041	B1	10/2001	Packer
6,173,316	B1	1/2001	De Boor et al.	6,301,480	B1	10/2001	Kennedy, III et al.
6,175,562	B1	1/2001	Cave	6,304,898	B1	10/2001	Shiigi
6,175,563	B1	1/2001	Miloslavsky	6,314,089	B1	11/2001	Szlam et al.
6,175,564	B1	1/2001	Miloslavsky et al.	6,314,430	B1	11/2001	Chang
6,175,620	B1	1/2001	Rouge et al.	6,320,857	B1	11/2001	Tonnby et al.
6,175,842	B1	1/2001	Kirk et al.	6,320,951	B1	11/2001	Shtivelman et al.
6,178,239	B1	1/2001	Kishinsky et al.	6,324,276	B1	11/2001	Uppaluru et al.
6,181,336	B1	1/2001	Chiu et al.	6,330,323	B1	12/2001	Gottlieb et al.
6,181,736	B1	1/2001	McLaughlin et al.	6,330,426	B2	12/2001	Brown et al.
6,181,788	B1	1/2001	Miloslavsky	6,332,022	B1	12/2001	Martinez
6,182,059	B1	1/2001	Angotti et al.	6,332,154	B2	12/2001	Beck et al.
6,182,249	B1	1/2001	Wookey et al.	6,332,163	B1	12/2001	Bowman-Amuah
6,185,184	B1	2/2001	Mattaway et al.	6,333,980	B1	12/2001	Hollatz et al.
6,185,287	B1	2/2001	Miloslavsky	6,335,927	B1	1/2002	Elliott et al.
6,185,291	B1	2/2001	Miloslavsky	6,337,904	B1	1/2002	Gisby
6,185,292	B1	2/2001	Miloslavsky	6,339,593	B1	1/2002	Kikinis
6,185,427	B1	2/2001	Krasner et al.	6,341,128	B1	1/2002	Svedberg
6,185,535	B1	2/2001	Hedin et al.	6,343,281	B1	1/2002	Kato
6,188,688	B1	2/2001	Buskirk, Jr.	6,345,290	B2	2/2002	Okada et al.
6,188,762	B1	2/2001	Shooster	6,345,300	B1	2/2002	Bakshi et al.
6,192,122	B1	2/2001	Flockhart et al.	6,345,305	B1	2/2002	Beck et al.
6,192,250	B1	2/2001	Buskens et al.	6,346,952	B1	2/2002	Shtivelman
6,192,338	B1	2/2001	Haszto et al.	6,347,085	B2	2/2002	Kelly
6,195,357	B1	2/2001	Polcyn	6,353,608	B1	3/2002	Cullers et al.
6,198,738	B1	3/2001	Chang et al.	6,353,667	B1	3/2002	Foster et al.
6,198,739	B1	3/2001	Neyman et al.	6,359,981	B1	3/2002	Neyman et al.
6,201,804	B1	3/2001	Kikinis	6,362,838	B1	3/2002	Szlam et al.
6,201,863	B1	3/2001	Miloslavsky	6,363,411	B1	3/2002	Dugan et al.
6,205,135	B1	3/2001	Chinni et al.	6,366,575	B1	4/2002	Barkan et al.
6,205,412	B1	3/2001	Barskiy et al.	6,366,586	B1	4/2002	Christie
6,212,178	B1	4/2001	Beck et al.	6,366,651	B1	4/2002	Griffith et al.
6,215,783	B1	4/2001	Neyman	6,366,656	B1	4/2002	Lee et al.
6,219,045	B1	4/2001	Leahy et al.	6,366,658	B1	4/2002	Bjornberg et al.
				6,366,663	B1	4/2002	Bauer et al.
				6,366,925	B1	4/2002	Meltzer et al.
				6,370,238	B1	4/2002	Sansone et al.
				6,370,508	B2	4/2002	Beck et al.

(56)

## References Cited

## U.S. PATENT DOCUMENTS

6,370,567	B1	4/2002	Ouchi	6,549,539	B1	4/2003	Neyman
6,373,836	B1	4/2002	Deryugin et al.	6,553,114	B1	4/2003	Fisher et al.
6,373,937	B1	4/2002	Yegoshin	6,554,183	B1	4/2003	Sticha et al.
6,377,568	B1	4/2002	Kelly	6,560,328	B1	5/2003	Bondarenko et al.
6,377,583	B1	4/2002	Lyles et al.	6,560,329	B1	5/2003	Draginich et al.
6,377,944	B1	4/2002	Busey et al.	6,560,607	B1	5/2003	Lassesen
6,377,975	B1	4/2002	Florman	6,563,788	B1	5/2003	Torba et al.
6,381,640	B1	4/2002	Beck et al.	6,567,854	B1	5/2003	Olshansky et al.
6,385,191	B1	5/2002	Coffinan et al.	6,581,105	B2	6/2003	Miloslavsky et al.
6,385,202	B1	5/2002	Katseff et al.	6,594,269	B1	7/2003	Polcyn
6,385,646	B1	5/2002	Brown et al.	6,594,347	B1	7/2003	Calder et al.
6,389,007	B1	5/2002	Shenkman et al.	6,597,685	B2	7/2003	Miloslavsky et al.
6,389,133	B1	5/2002	Kamen	6,600,733	B2	7/2003	Deng
6,393,018	B2	5/2002	Miloslavsky	6,600,822	B2	7/2003	Kamen
6,393,122	B1	5/2002	Belzile	6,603,762	B1	8/2003	Kikinis
6,393,278	B1	5/2002	Buchanan et al.	6,603,854	B1	8/2003	Judkins et al.
6,393,481	B1	5/2002	Deo et al.	6,611,498	B1	8/2003	Baker et al.
6,396,834	B1	5/2002	Bonomi et al.	6,611,590	B1	8/2003	Lu et al.
6,396,919	B1	5/2002	Shimada et al.	6,614,780	B2	9/2003	Hakim et al.
6,400,725	B1	6/2002	Ross	6,614,781	B1	9/2003	Elliott et al.
6,401,066	B1	6/2002	McIntosh	6,625,139	B2	9/2003	Miloslavsky et al.
6,401,094	B1	6/2002	Stemp et al.	6,628,666	B1	9/2003	Pickering et al.
6,405,033	B1	6/2002	Kennedy, III et al.	6,631,399	B1	10/2003	Stanczak et al.
6,407,996	B1	6/2002	Witchalls	6,633,910	B1	10/2003	Rajan et al.
6,407,999	B1	6/2002	Olkkonen et al.	6,650,747	B1	11/2003	Bala et al.
6,408,064	B1	6/2002	Fedorov et al.	6,651,085	B1	11/2003	Woods
6,411,806	B1	6/2002	Garner et al.	6,658,389	B1	12/2003	Alpdemir
6,418,146	B1	7/2002	Miloslavsky	6,661,882	B1	12/2003	Muir et al.
6,418,199	B1	7/2002	Perrone	6,665,395	B1	12/2003	Busey et al.
6,424,709	B1	7/2002	Doyle et al.	6,665,396	B1	12/2003	Khoury et al.
6,427,002	B2	7/2002	Campbell et al.	6,668,286	B2	12/2003	Bateman et al.
6,430,174	B1	8/2002	Jennings et al.	6,678,718	B1	1/2004	Khoury et al.
6,430,282	B1	8/2002	Bannister et al.	6,681,010	B1	1/2004	Anderson et al.
6,434,231	B2	8/2002	Neyman et al.	6,687,241	B1	2/2004	Goss
6,434,530	B1	8/2002	Sloane et al.	6,690,788	B1	2/2004	Bauer et al.
6,434,549	B1	8/2002	Linetsky et al.	6,693,893	B1	2/2004	Ehlinger
6,442,242	B1	8/2002	McAllister et al.	6,704,394	B1	3/2004	Kambhatla et al.
6,442,247	B1	8/2002	Garcia	6,704,409	B1	3/2004	Dilip et al.
6,445,788	B1	9/2002	Torba	6,704,410	B1	3/2004	McFarlane et al.
6,449,260	B1	9/2002	Sassin et al.	6,704,411	B1	3/2004	Nishidate
6,449,270	B1	9/2002	Miloslavsky	6,707,903	B2	3/2004	Burok et al.
6,449,358	B1	9/2002	Anisimov et al.	6,711,249	B2	3/2004	Weissman et al.
6,449,646	B1	9/2002	Sikora et al.	6,711,611	B2	3/2004	Hanhan
6,452,609	B1	9/2002	Katinsky et al.	6,714,643	B1	3/2004	Gargeya et al.
6,453,038	B1	9/2002	McFarlane et al.	6,718,032	B1	4/2004	Vrenjak et al.
6,453,341	B1	9/2002	Miloslavsky	6,718,366	B2	4/2004	Johnstone et al.
6,456,615	B1	9/2002	Kikinis	6,721,306	B1	4/2004	Farris et al.
6,456,619	B1	9/2002	Sassin et al.	6,731,626	B1	5/2004	Neyman
6,459,697	B1	10/2002	Neyman	6,735,298	B2	5/2004	Neyman et al.
6,463,148	B1	10/2002	Brady	6,744,877	B1	6/2004	Edwards
6,470,010	B1	10/2002	Szviatovszki et al.	6,744,878	B1	6/2004	Komissarchik et al.
6,470,080	B2	10/2002	Perlmutter	6,748,211	B1	6/2004	Isaac et al.
6,473,787	B2	10/2002	Miloslavsky	6,751,210	B1	6/2004	Shaffer et al.
6,480,600	B1	11/2002	Neyman et al.	6,753,784	B1	6/2004	Sznaider et al.
6,487,663	B1	11/2002	Jaisimha et al.	6,754,181	B1	6/2004	Elliott et al.
6,489,954	B1	12/2002	Powlette	6,760,322	B1	7/2004	Fukuda et al.
6,490,350	B2	12/2002	McDuff et al.	6,760,324	B1	7/2004	Scott et al.
6,493,353	B2	12/2002	Kelly et al.	6,760,428	B2	7/2004	Foster
6,493,433	B2	12/2002	Clabaugh et al.	6,760,727	B1	7/2004	Schroeder et al.
6,493,447	B1	12/2002	Goss et al.	6,763,104	B1	7/2004	Judkins et al.
6,496,567	B1	12/2002	Bjornberg et al.	6,763,369	B1	7/2004	Yuarte et al.
6,496,702	B1	12/2002	Lockhart	6,771,765	B1	8/2004	Crowther et al.
6,496,981	B1	12/2002	Wistendahl et al.	6,778,527	B1	8/2004	Amin
6,498,897	B1	12/2002	Nelson et al.	6,785,375	B1	8/2004	Beddus et al.
6,499,088	B1	12/2002	Wexler et al.	6,785,710	B2	8/2004	Kikinis
6,512,825	B1	1/2003	Lindholm et al.	6,785,740	B1	8/2004	Yoneda et al.
6,515,996	B1	2/2003	Tonnby et al.	6,788,779	B2	9/2004	Ostapchuck
6,519,246	B1	2/2003	Strahs	6,798,771	B1	9/2004	Low et al.
6,519,617	B1	2/2003	Wanderski et al.	6,801,520	B2	10/2004	Philonenko
6,532,493	B1	3/2003	Aviani, Jr. et al.	6,801,928	B2	10/2004	Nuestro
6,535,492	B2	3/2003	Shtivelman	6,804,346	B1	10/2004	Mewhinney
6,535,601	B1	3/2003	Flockhart et al.	6,816,871	B2	11/2004	Lee
6,536,043	B1	3/2003	Guedalia	6,816,878	B1	11/2004	Zimmers et al.
6,539,419	B2	3/2003	Beck et al.	6,823,197	B1	11/2004	Chen et al.
6,546,405	B2	4/2003	Gupta et al.	6,829,349	B1	12/2004	Neale et al.
				6,845,154	B1	1/2005	Cave et al.
				6,847,715	B1	1/2005	Swartz
				6,847,825	B1	1/2005	Duvall et al.
				6,850,602	B1	2/2005	Chou

(56)

## References Cited

## U.S. PATENT DOCUMENTS

6,850,614	B1	2/2005	Collins	7,363,228	B2	4/2008	Wyss et al.
6,859,529	B2	2/2005	Duncan et al.	7,372,956	B1	5/2008	Kikinis et al.
6,865,267	B2	3/2005	Dezonne	7,373,405	B2	5/2008	Deryugin et al.
6,868,391	B1	3/2005	Hultgren	7,373,410	B2	5/2008	Monza et al.
6,874,119	B2	3/2005	Macleod Beck et al.	7,376,227	B2	5/2008	Anisimov et al.
6,876,632	B1	4/2005	Takeda	7,376,431	B2	5/2008	Niedermeyer
6,879,586	B2	4/2005	Miloslavsky et al.	7,401,112	B1	7/2008	Matz et al.
6,882,996	B2	4/2005	Preisig et al.	7,415,009	B2	8/2008	Neyman
6,898,190	B2	5/2005	Shtivelman et al.	7,418,094	B2	8/2008	Golitsin et al.
6,903,685	B1	6/2005	Arndt et al.	7,428,303	B2	9/2008	Campbell et al.
6,907,112	B1	6/2005	Guedalia et al.	7,434,204	B1	10/2008	Everingham et al.
6,907,455	B1	6/2005	Wolfe et al.	7,457,279	B1	11/2008	Scott et al.
6,910,072	B2	6/2005	Macleod Beck et al.	7,460,496	B2	12/2008	Miloslavsky et al.
6,912,272	B2	6/2005	Kirk et al.	7,496,640	B2	2/2009	Hanhan
6,922,411	B1	7/2005	Taylor	7,535,479	B2	5/2009	Okita et al.
6,922,689	B2	7/2005	Shtivelman	7,558,383	B2	7/2009	Shtivelman et al.
6,925,161	B2	8/2005	Burg et al.	7,561,887	B2	7/2009	Lockhart
6,934,379	B2	8/2005	Falcon et al.	7,564,840	B2	7/2009	Elliott et al.
6,934,381	B1	8/2005	Klein et al.	7,565,428	B2	7/2009	Deryugin et al.
6,944,272	B1	9/2005	Thomas	7,609,829	B2	10/2009	Wang et al.
6,958,994	B2	10/2005	Zhakov et al.	7,610,347	B2	10/2009	Petrovykh
6,965,870	B1	11/2005	Petras et al.	7,619,996	B2	11/2009	Miloslavsky et al.
6,965,914	B2	11/2005	Dowling	7,653,744	B2	1/2010	Kanefsky et al.
6,970,844	B1	11/2005	Bierenbaum	7,669,182	B2	2/2010	Garcia
6,977,740	B1	12/2005	Mandalia	7,672,998	B1	3/2010	Haskins et al.
6,981,020	B2	12/2005	Miloslavsky et al.	7,706,520	B1	4/2010	Waterson et al.
6,985,478	B2	1/2006	Pogossiants et al.	7,715,332	B2	5/2010	Miloslavsky et al.
6,985,943	B2	1/2006	Deryugin et al.	7,716,292	B2	5/2010	Kikinis
6,987,977	B2	1/2006	Lockhart	7,739,325	B1	6/2010	Okita et al.
6,996,603	B1	2/2006	Srinivasan	7,764,231	B1	7/2010	Karr et al.
7,006,614	B2	2/2006	Feinberg et al.	7,769,161	B1	8/2010	Hession et al.
7,020,264	B1	3/2006	Neyman et al.	7,779,067	B2	8/2010	Beck et al.
7,031,442	B1	4/2006	Neyman et al.	7,792,773	B2	9/2010	McCord et al.
7,036,128	B1	4/2006	Julia et al.	7,808,977	B2	10/2010	Kikinis
7,039,176	B2	5/2006	Borodow et al.	7,823,167	B2	10/2010	Makagon et al.
7,039,857	B2	5/2006	Beck et al.	7,853,717	B2	12/2010	Petrovykh
7,076,048	B2	7/2006	Lee et al.	7,856,095	B2	12/2010	Brown
7,079,641	B2	7/2006	Ostapchuck	7,903,807	B2	3/2011	Neyman et al.
7,080,092	B2	7/2006	Upton	7,907,598	B2	3/2011	Anisimov et al.
7,088,814	B1	8/2006	Shaffer et al.	7,929,978	B2	4/2011	Lockhart
7,092,509	B1	8/2006	Mears et al.	7,957,401	B2	6/2011	Zalenski et al.
7,106,850	B2	9/2006	Campbell et al.	8,009,821	B1	8/2011	Apparao et al.
7,110,523	B2	9/2006	Gagle et al.	8,018,921	B2	9/2011	Pogossiants et al.
7,110,525	B1	9/2006	Heller et al.	8,024,401	B1	9/2011	Gurbani et al.
7,117,244	B2	10/2006	Florman et al.	8,031,698	B2	10/2011	Neyman
7,120,700	B2	10/2006	Macleod Beck et al.	8,036,214	B2	10/2011	Elliott et al.
7,127,400	B2	10/2006	Koch	8,059,812	B1	11/2011	Bundy
7,133,830	B1	11/2006	Hoban et al.	8,068,598	B1	11/2011	Russi et al.
7,136,475	B1	11/2006	Rogers et al.	8,085,761	B2	12/2011	Elliott et al.
7,155,496	B2	12/2006	Froyd et al.	8,089,958	B2	1/2012	Elliott et al.
7,155,512	B2	12/2006	Lean et al.	8,126,133	B1	2/2012	Everingham et al.
7,159,224	B2	1/2007	Sharma et al.	8,130,749	B2	3/2012	Kikinis
7,167,924	B1	1/2007	Symonds et al.	8,180,662	B2	5/2012	Minert et al.
7,184,747	B2	2/2007	Bogat	8,180,666	B2	5/2012	Minert et al.
7,216,350	B2	5/2007	Martin et al.	8,199,891	B2	6/2012	Brown et al.
7,221,377	B1	5/2007	Okita et al.	8,209,207	B2	6/2012	Minert et al.
7,222,301	B2	5/2007	Makagon et al.	8,209,209	B2	6/2012	Minert et al.
7,231,032	B2	6/2007	Nevman et al.	8,223,948	B2	7/2012	Minert et al.
7,236,486	B2	6/2007	Baker et al.	8,226,477	B1	7/2012	Machado et al.
7,236,584	B2	6/2007	Torba	8,254,404	B2	8/2012	Rabenko et al.
7,242,760	B2	7/2007	Shires	8,254,558	B2	8/2012	Minert et al.
7,245,641	B2	7/2007	Kim et al.	8,270,421	B2	9/2012	Elliott et al.
7,245,711	B2	7/2007	Margolis	8,275,111	B2	9/2012	Golitsin et al.
7,246,009	B2	7/2007	Hamblen et al.	8,345,856	B1	1/2013	Anisimov et al.
7,254,219	B1	8/2007	Hansen et al.	8,351,595	B2	1/2013	Peterson et al.
7,254,641	B2	8/2007	Broughton et al.	8,358,769	B2	1/2013	Neyman et al.
7,263,372	B2	8/2007	Lockhart	8,395,994	B2	3/2013	Stevenson et al.
7,263,671	B2	8/2007	Hull et al.	8,396,205	B1	3/2013	Lowry et al.
7,269,263	B2	9/2007	Dedieu et al.	8,411,844	B1	4/2013	Anisimov et al.
7,272,627	B2	9/2007	Petrovykh	8,693,347	B2	4/2014	Elliott et al.
7,277,424	B1	10/2007	Dowling	9,002,920	B2	4/2015	Deryugin et al.
7,277,536	B2	10/2007	Ostapchuk	RE45,583	E	6/2015	Lockhart
7,277,916	B2	10/2007	Nuestro	9,118,781	B1	8/2015	Kavulak et al.
7,283,519	B2	10/2007	Girard	9,241,258	B2	1/2016	Ku et al.
7,336,649	B1	2/2008	Huang	9,247,053	B1	1/2016	Bruce et al.
				2001/0000458	A1	4/2001	Shtivelman et al.
				2001/0001150	A1	5/2001	Miloslavsky
				2001/0005382	A1	6/2001	Cave et al.
				2001/0008555	A1	7/2001	Bae et al.



(56)

## References Cited

## U.S. PATENT DOCUMENTS

2001/0011366	A1	8/2001	Beck et al.	2003/0055884	A1	3/2003	Yuen et al.
2001/0013041	A1	8/2001	Macleod Beck et al.	2003/0058884	A1	3/2003	Kallner et al.
2001/0014604	A1	8/2001	Kingdon et al.	2003/0084128	A1	5/2003	Anderson et al.
2001/0023430	A1	9/2001	Srinivasan	2003/0084349	A1	5/2003	Friedrichs et al.
2001/0023448	A1	9/2001	Hanhan	2003/0088421	A1	5/2003	Maes et al.
2001/0024497	A1	9/2001	Campbell et al.	2003/0097457	A1	5/2003	Saran et al.
2001/0025309	A1	9/2001	Macleod Beck et al.	2003/0099343	A1	5/2003	Dezonno
2001/0028649	A1	10/2001	Pogossiants et al.	2003/0115353	A1	6/2003	Deryugin et al.
2001/0029519	A1	10/2001	Hallinan et al.	2003/0125048	A1	7/2003	Lockhart
2001/0037316	A1	11/2001	Shiloh	2003/0135592	A1	7/2003	Vetter et al.
2001/0038624	A1	11/2001	Greenberg et al.	2003/0161296	A1	8/2003	Butler et al.
2001/0040887	A1	11/2001	Shtivelman et al.	2003/0161448	A1	8/2003	Parolkar et al.
2001/0042095	A1	11/2001	Kim et al.	2003/0179729	A1	9/2003	MacLeod Beck et al.
2001/0043586	A1	11/2001	Miloslavsky	2003/0212558	A1	11/2003	Matula
2001/0043589	A1	11/2001	Kikinis	2003/0216923	A1	11/2003	Gilmore et al.
2001/0044676	A1	11/2001	Macleod Beck et al.	2003/0219029	A1	11/2003	Pickett
2001/0044828	A1	11/2001	Kikinis	2003/0220875	A1	11/2003	Lam et al.
2001/0047262	A1	11/2001	Kurganov et al.	2003/0229529	A1	12/2003	Mui et al.
2001/0054064	A1	12/2001	Kannan	2004/0006739	A1	1/2004	Mulligan
2002/0001300	A1	1/2002	Miloslavsky et al.	2004/0017797	A1	1/2004	Chen et al.
2002/0012428	A1	1/2002	Neyman et al.	2004/0019638	A1	1/2004	Makagon et al.
2002/0013150	A1	1/2002	McKenna et al.	2004/0030557	A1	2/2004	Culy et al.
2002/0019844	A1	2/2002	Kurowski et al.	2004/0047302	A1	3/2004	Dezonno et al.
2002/0019846	A1	2/2002	Miloslavsky et al.	2004/0054743	A1	3/2004	McPartlan et al.
2002/0025819	A1	2/2002	Cetusic et al.	2004/0064348	A1	4/2004	Humenansky et al.
2002/0035647	A1	3/2002	Brown et al.	2004/0081183	A1	4/2004	Monza et al.
2002/0037076	A1	3/2002	Perlmutter	2004/0083195	A1	4/2004	McCord et al.
2002/0041674	A1	4/2002	Kamen	2004/0083281	A1	4/2004	Makagon et al.
2002/0054579	A1	5/2002	Miloslavsky	2004/0083479	A1	4/2004	Bondarenko et al.
2002/0055853	A1	5/2002	Macleod Beck et al.	2004/0083482	A1	4/2004	Makagon et al.
2002/0056000	A1	5/2002	Albert Coussement	2004/0102977	A1	5/2004	Metzler et al.
2002/0057671	A1	5/2002	Kikinis	2004/0107025	A1	6/2004	Ransom et al.
2002/0059164	A1	5/2002	Shtivelman	2004/0111269	A1	6/2004	Koch
2002/0059374	A1	5/2002	Nuestro	2004/0120502	A1	6/2004	Strathmeyer et al.
2002/0060988	A1	5/2002	Shtivelman	2004/0169675	A1	9/2004	Beck et al.
2002/0062385	A1	5/2002	Dowling	2004/0179516	A1	9/2004	Neyman
2002/0064149	A1	5/2002	Elliott et al.	2004/0181574	A1	9/2004	Hanhan
2002/0071529	A1	6/2002	Nelkenbaum	2004/0199580	A1	10/2004	Zhakov et al.
2002/0076031	A1	6/2002	Falcon et al.	2004/0208134	A1	10/2004	Neyman et al.
2002/0078150	A1	6/2002	Thompson et al.	2004/0208309	A1	10/2004	Miloslavsky
2002/0087648	A1	7/2002	Petrovykh	2004/0213400	A1	10/2004	Golitsin et al.
2002/0091527	A1	7/2002	Shiau	2004/0223490	A1	11/2004	Donovan et al.
2002/0091726	A1	7/2002	Macleod Beck et al.	2004/0264678	A1	12/2004	Ostapchuck
2002/0095462	A1	7/2002	Beck et al.	2004/0267892	A1	12/2004	Kikinis
2002/0097708	A1	7/2002	Deng	2005/0013417	A1	1/2005	Zimmers et al.
2002/0099738	A1	7/2002	Grant	2005/0033851	A1	2/2005	Kikinis
2002/0101866	A1	8/2002	Miloslavsky et al.	2005/0041678	A1	2/2005	Nuestro
2002/0101880	A1	8/2002	Kim	2005/0128961	A1	6/2005	Miloslavsky et al.
2002/0103998	A1	8/2002	DeBruine	2005/0147090	A1	7/2005	MacLeod Beck et al.
2002/0105957	A1	8/2002	Bondarenko et al.	2005/0154792	A1	7/2005	Deryugin et al.
2002/0114278	A1	8/2002	Coussement	2005/0207559	A1	9/2005	Shtivelman et al.
2002/0114441	A1	8/2002	Coussement	2006/0029206	A1	2/2006	Anisimov et al.
2002/0120719	A1	8/2002	Lee et al.	2006/0034262	A1	2/2006	Pogossiants et al.
2002/0123899	A1	9/2002	Hall et al.	2006/0079250	A1	4/2006	Lockhart
2002/0126678	A1	9/2002	Kelly et al.	2006/0080107	A1	4/2006	Hill et al.
2002/0126828	A1	9/2002	Kamen	2006/0095568	A1	5/2006	Makagon et al.
2002/0131399	A1	9/2002	Philonenko	2006/0109976	A1	5/2006	Sundaram et al.
2002/0136167	A1	9/2002	Steele et al.	2006/0133594	A1	6/2006	Neyman et al.
2002/0150311	A1	10/2002	Lynn	2006/0153173	A1	7/2006	Beck et al.
2002/0169834	A1	11/2002	Miloslavsky et al.	2006/0209797	A1	9/2006	Anisimov et al.
2002/0174436	A1	11/2002	Wu et al.	2006/0210047	A1	9/2006	Neyman et al.
2002/0176404	A1	11/2002	Girard	2006/0245421	A1	11/2006	Ostapchuk
2003/0002479	A1	1/2003	Vortman et al.	2007/0002744	A1	1/2007	Mewhinney et al.
2003/0002652	A1	1/2003	Neyman et al.	2007/0041525	A1	2/2007	Tingley et al.
2003/0002654	A1	1/2003	Torba	2007/0041567	A1	2/2007	Anisimov et al.
2003/0007621	A1	1/2003	Graves et al.	2007/0071224	A1	3/2007	Shtivelman et al.
2003/0009530	A1	1/2003	Philonenko et al.	2007/0110043	A1	5/2007	Girard
2003/0018702	A1	1/2003	Broughton et al.	2007/0127707	A1	6/2007	Koser et al.
2003/0018729	A1	1/2003	Miloslavsky	2007/0143301	A1	6/2007	Tran
2003/0021259	A1	1/2003	Miloslavsky et al.	2007/0195940	A1	8/2007	Miloslavsky et al.
2003/0021406	A1	1/2003	Ostapchuck	2007/0213073	A1	9/2007	Lockhart
2003/0026414	A1	2/2003	Baker et al.	2007/0274495	A1	11/2007	Youd et al.
2003/0037113	A1	2/2003	Petrovykh	2008/0002822	A1	1/2008	Petrovykh
2003/0043832	A1	3/2003	Anisimov et al.	2008/0013531	A1	1/2008	Elliott et al.
2003/0051037	A1	3/2003	Sundaram et al.	2008/0025295	A1	1/2008	Elliott et al.
				2008/0034354	A1	2/2008	Brughton et al.
				2008/0043728	A1	2/2008	Miloslavsky et al.
				2008/0043955	A1	2/2008	Shtivelman et al.
				2008/0043975	A1	2/2008	Miloslavsky et al.

(56)	<b>References Cited</b>			AU	1118899	5/1999
	U.S. PATENT DOCUMENTS			AU	740090 B2	6/1999
				AU	743737 B2	6/1999
				AU	744340 B2	6/1999
2008/0043977	A1	2/2008	Neyman et al.	AU	1120099	6/1999
2008/0046504	A1	2/2008	Deryugin et al.	AU	1276799	6/1999
2008/0046531	A1	2/2008	Shtivelman et al.	AU	1286299	6/1999
2008/0049731	A1	2/2008	Kikinis	AU	741437 B2	8/1999
2008/0049737	A1	2/2008	Neyman	AU	758713 B2	8/1999
2008/0049928	A1	2/2008	Miloslavsky et al.	AU	2595499	8/1999
2008/0049929	A1	2/2008	Miloslavsky et al.	AU	2595599	8/1999
2008/0062971	A1	3/2008	Kikinis	AU	2667299	8/1999
2008/0130844	A1	6/2008	Hubbard et al.	AU	2674899	8/1999
2008/0205378	A1	8/2008	Wyss et al.	AU	739979 B2	9/1999
2008/0222240	A1	9/2008	Deryugin et al.	AU	2674799	9/1999
2008/0285739	A1	11/2008	Golitsin et al.	AU	749023 B2	12/1999
2009/0089136	A1	4/2009	Minert et al.	AU	4427299	12/1999
2009/0089451	A1	4/2009	Petrovykh	AU	4819499	12/1999
2009/0227267	A1	9/2009	Lockhart	AU	746085 B2	1/2000
2009/0240346	A1	9/2009	Cadigan, Jr. et al.	AU	4426799	1/2000
2010/0106710	A1	4/2010	Nishizawa et al.	AU	750215 B2	4/2000
2010/0157979	A1	6/2010	Anisimov et al.	AU	754238 B2	4/2000
2010/0198930	A1	8/2010	Kikinis	AU	755234 B2	4/2000
2011/0099602	A1	4/2011	Apparao et al.	AU	5807099	4/2000
2011/0110363	A1	5/2011	Anandani	AU	5810599	4/2000
2011/0178946	A1	7/2011	Minert et al.	AU	5813699	4/2000
2011/0179304	A1	7/2011	Peterson	AU	748456 B2	5/2000
2011/0179398	A1	7/2011	Peterson	AU	751143 B2	5/2000
2011/0182418	A1	7/2011	Anisimov et al.	AU	751232 B2	5/2000
2012/0047266	A1	2/2012	Minert	AU	751269 B2	5/2000
2012/0066016	A1	3/2012	Minert et al.	AU	751301 B2	5/2000
2012/0177195	A1	7/2012	Elliott et al.	AU	755138 B2	5/2000
2012/0195415	A1	8/2012	Wyss et al.	AU	1233800	5/2000
2012/0250849	A1	10/2012	Liu et al.	AU	1327200	5/2000
2013/0016115	A1	1/2013	Minert et al.	AU	1328200	5/2000
2013/0070757	A1	3/2013	Elliott et al.	AU	1328300	5/2000
2013/0129067	A1	5/2013	Neyman et al.	AU	1454700	5/2000
2013/0230160	A1	9/2013	Neyman et al.	AU	1717700	5/2000
2014/0376708	A1	12/2014	Deryugin et al.	AU	1718600	5/2000
2014/0379936	A1	12/2014	Anisimov et al.	AU	2045900	6/2000
2015/0201021	A1	7/2015	Beck et al.	AU	748447 B2	7/2000
2015/0244870	A1	8/2015	Neyman et al.	AU	3113800	7/2000
				AU	2964900	9/2000
				AU	3470800	9/2000
				AU	4507700	2/2001
				AU	6798300	4/2001
				AU	1077201	6/2001
				AU	1077301	6/2001
				AU	8006800	6/2001
				AU	4732501	10/2001
				AU	5384201	10/2001
				AU	5724801	11/2001
				AU	756656 B2	1/2003
				AU	2003300117	8/2004
				BR	9913621 A	5/2001
				BR	9913622 A	5/2001
				CA	2178705 A1	3/1997
				CA	2391428 A1	3/1997
				CA	2259912 C	1/1998
				CA	2280002 A1	8/1998
				CA	2289193 A1	12/1998
				CA	2289198 A1	12/1998
				CA	2302397 A1	3/1999
				CA	2302488 A1	3/1999
				CA	2302674 A1	3/1999
				CA	2302680 A1	3/1999
				CA	2302704 A1	3/1999
				CA	2302678 A1	4/1999
				CA	2308590 A1	5/1999
				CA	2309185 A1	5/1999
				CA	2309186 A1	5/1999
				CA	2309183 A1	6/1999
				CA	2320978 A1	8/1999
				CA	2320979 A1	8/1999
				CA	2320989 A1	8/1999
				CA	2330608 A1	12/1999
				CA	2334513 A1	12/1999
				CA	2343286 A1	3/2000
				CA	2343288 A1	3/2000
				CA	2343288 A1	3/2000
AT	316736	2/2006				
AT	317621	2/2006				
AT	318048	3/2006				
AT	337678	9/2006				
AT	379921	12/2007				
AT	380434	12/2007				
AT	384398	2/2008				
AT	388578	3/2008				
AT	401736	8/2008				
AT	413059	11/2008				
AT	424090	3/2009				
AT	465451	5/2010				
AT	474415	7/2010				
AU	2604797	10/1997				
AU	718233 B2	3/1998				
AU	5274398	3/1998				
AU	6023598	8/1998				
AU	6034698	8/1998				
AU	6167398	8/1998				
AU	6319498	8/1998				
AU	6655298	9/1998				
AU	6655398	9/1998				
AU	7099298	10/1998				
AU	735134 B2	3/1999				
AU	736449 B2	4/1999				
AU	737483 B2	4/1999				
AU	743217 B2	4/1999				
AU	745404 B2	4/1999				
AU	748636 B2	4/1999				
AU	9225198	4/1999				
AU	9228098	4/1999				
AU	9381998	4/1999				
AU	9479298	4/1999				
AU	743880 B2	5/1999				

(56) References Cited			EP	0740450 A2	10/1996
FOREIGN PATENT DOCUMENTS			EP	0748102 A2	12/1996
CA	2343756 A1	3/2000	EP	0753956 A2	1/1997
CA	2347721 A1	5/2000	EP	0755146 A2	1/1997
CA	2348567 A1	5/2000	EP	0758175 A1	2/1997
CA	2348574 A1	5/2000	EP	0771095 A2	5/1997
CA	2348575 C	5/2000	EP	0792076 A2	8/1997
CA	2348994 A1	5/2000	EP	0806858 A2	11/1997
CA	2348999 A1	5/2000	EP	0817455 A2	1/1998
CA	2350515 A1	5/2000	EP	0856980 A2	8/1998
CA	2352973 A1	6/2000	EP	0863651 A2	9/1998
CA	2362172 A1	8/2000	EP	0866407 A1	9/1998
CA	2313596 A1	2/2001	EP	0869639 A2	10/1998
CN	1282484 A	1/2001	EP	0883306 A2	12/1998
CN	1282485 A	1/2001	EP	0908047 A1	4/1999
CN	1285990 A	2/2001	EP	0958560 A1	11/1999
CN	1285991 A	2/2001	EP	0962087 A1	12/1999
CN	1293798 A	5/2001	EP	1006706 A2	6/2000
CN	1293858 A	5/2001	EP	1013062 A1	6/2000
CN	1298590 A	6/2001	EP	1013066 A1	6/2000
CN	1309861 A	8/2001	EP	1016280 A1	7/2000
CN	1310822 A	8/2001	EP	1044553 A1	10/2000
CN	1323418 A	11/2001	EP	1064630 A1	1/2001
CN	1323421 A	11/2001	EP	1066712 A1	1/2001
CN	1354942 A	6/2002	EP	1075153 A2	2/2001
CN	1130061 C	12/2003	EP	1087597 A2	3/2001
CN	1132399 C	12/2003	EP	1088277 A1	4/2001
CN	1145314 C	4/2004	EP	1092313 A1	4/2001
CN	1149521 C	5/2004	EP	1107555 A2	6/2001
CN	1152549 C	6/2004	EP	1114543 A1	7/2001
CN	1512724 A	7/2004	EP	1125214 A1	8/2001
CN	1520197 A	8/2004	EP	1133677 A2	9/2001
CN	1197336 C	4/2005	EP	1133736 A1	9/2001
CN	1200548 C	5/2005	EP	1133742 A1	9/2001
CN	1662025 A	8/2005	EP	1145153 A1	10/2001
CN	1232077 C	12/2005	EP	1145154 A1	10/2001
CN	1756280 A	4/2006	EP	1163564 A2	12/2001
CN	100477702 C	4/2009	EP	1193961 A2	4/2002
CN	100547568 C	10/2009	EP	1227635 A2	7/2002
CN	102257789 A	11/2011	EP	1248447 A2	10/2002
CN	101635775 B	12/2011	EP	1290861 A1	3/2003
DE	60011863 T2	12/2004	EP	1292901 A1	3/2003
DE	69730498 T2	9/2005	EP	1292939 A1	3/2003
DE	60015236 T2	2/2006	EP	1328121 A1	7/2003
DE	69832275 T2	8/2006	EP	0873642 B1	4/2004
DE	69833285 T2	9/2006	EP	1413954 A2	4/2004
DE	69833394 T2	10/2006	EP	1107615 B1	6/2004
DE	69833462 T2	10/2006	EP	1033024 A4	9/2004
DE	69833935 T2	11/2006	EP	1129545 A1	9/2004
DE	60214191 T2	12/2006	EP	1061723 B1	10/2004
DE	69834184 T2	3/2007	EP	1465397 A1	10/2004
DE	69838795 T2	10/2008	EP	1469663 A1	10/2004
DE	69838814 T2	11/2008	EP	1484903 A2	12/2004
DE	69839022 T2	1/2009	EP	1566949 A1	8/2005
DE	69839222 T2	3/2009	EP	0985308 B1	11/2005
EP	0193961 A2	9/1986	EP	1359735 B1	1/2006
EP	0236013 A2	9/1987	EP	1357729 B1	2/2006
EP	0376517 A2	7/1990	EP	1377001 B1	2/2006
EP	0420779 A2	4/1991	EP	0954922 B1	3/2006
EP	0424015 A2	4/1991	EP	0986875 B1	4/2006
EP	0425161 A2	5/1991	EP	1410614 B1	8/2006
EP	0425163 A2	5/1991	EP	1774760 A2	4/2007
EP	0515068 A2	11/1992	EP	1021905 B1	11/2007
EP	0528732 A1	2/1993	EP	1031232 B1	12/2007
EP	0532972 A1	3/1993	EP	1865697 A3	12/2007
EP	0539105 A2	4/1993	EP	1040638 B1	1/2008
EP	0559979 A2	9/1993	EP	1048162 B1	3/2008
EP	0568770 A2	11/1993	EP	1157509 B1	7/2008
EP	0610625 A2	8/1994	EP	1337079 B1	9/2008
EP	0647050 A2	4/1995	EP	1326415 B1	10/2008
EP	0647051 A1	4/1995	EP	1013054 B1	2/2009
EP	0660573 A2	6/1995	EP	1333653 B1	4/2009
EP	0701358 A1	3/1996	EP	0983676 B1	6/2009
EP	0705017 A2	4/1996	EP	1125208 B1	4/2010
EP	0721268 A2	7/1996	EP	1142284 B1	7/2010
EP	0725526 A2	8/1996	EP	2380323 A1	10/2011
EP	0734187 A2	9/1996	EP	1408678 B1	11/2011
			EP	1057301 B1	8/2013
			EP	1131728 B1	1/2014

(56) References Cited					
FOREIGN PATENT DOCUMENTS					
EP	1625460 B1	5/2014	JP	10-506766	6/1998
ES	2231120 T3	5/2005	JP	10-214113	8/1998
ES	2255657 T3	7/2006	JP	10-224477	8/1998
ES	2256666 T3	7/2006	JP	10-509847	9/1998
ES	2257639 T3	8/2006	JP	10-304073	11/1998
FR	2671252 A1	7/1992	JP	10-304074	11/1998
GB	2273225 A	6/1994	JP	10-327258	12/1998
GB	2306853 A	5/1997	JP	10-513632	12/1998
GB	2315190 A	1/1998	JP	11055741	2/1999
GB	2324627 A	10/1998	JP	11-506292	6/1999
GB	2369263 A	5/2002	JP	11-508430	7/1999
JP	61-51247	3/1986	JP	11-508715	7/1999
JP	62-200956	9/1987	JP	11183189	7/1999
JP	63-149955	6/1988	JP	11-317817	11/1999
JP	64-7460	1/1989	JP	11-512906	11/1999
JP	64-77265	3/1989	JP	11-346266	12/1999
JP	02-170756	7/1990	JP	2000-011005	1/2000
JP	02-298154	12/1990	JP	2000-49847	2/2000
JP	03-052443	3/1991	JP	2000-151819	5/2000
JP	03-160865	7/1991	JP	2000-514985	11/2000
JP	03-177144	8/1991	JP	2000-514986	11/2000
JP	04-40723	2/1992	JP	2000-516432	12/2000
JP	4-66858	6/1992	JP	2000-516795	12/2000
JP	04-265049	9/1992	JP	2000-517142	12/2000
JP	4-336742	11/1992	JP	2001-500677	1/2001
JP	04-371056	12/1992	JP	2001-103533	4/2001
JP	06-044157	2/1994	JP	2001-292236	10/2001
JP	06-046150	2/1994	JP	2001-516993	10/2001
JP	06-066830	3/1994	JP	2001-517027	10/2001
JP	06-069988	3/1994	JP	2001-517029	10/2001
JP	06-83771	3/1994	JP	2001-517038	10/2001
JP	06-90292	3/1994	JP	2001-518754	10/2001
JP	06-103058	4/1994	JP	2001-522201	11/2001
JP	06-121051	4/1994	JP	2001-523930	11/2001
JP	06-284203	7/1994	JP	3226929 B2	11/2001
JP	06-261129	9/1994	JP	2001-524782	12/2001
JP	06-291877	10/1994	JP	2001-526871	12/2001
JP	06-334748	12/1994	JP	2002-503903	2/2002
JP	07-046321	2/1995	JP	2002-503921	2/2002
JP	07-058851	3/1995	JP	2002-504783	2/2002
JP	07-115471	5/1995	JP	2002-518890	6/2002
JP	07-170288	7/1995	JP	2002-519762	7/2002
JP	07-170546	7/1995	JP	2002-525895	8/2002
JP	07-262104	10/1995	JP	2002-528824	9/2002
JP	07-212471	11/1995	JP	2002-529836	9/2002
JP	07-319538	12/1995	JP	2002-529943	9/2002
JP	07-336447	12/1995	JP	2002-529944	9/2002
JP	08-46699	2/1996	JP	2002-529945	9/2002
JP	08-056377	2/1996	JP	2002-529994	9/2002
JP	08-163252	6/1996	JP	2002-529994	9/2002
JP	08-181793	7/1996	JP	2002-530010	9/2002
JP	08-504305	7/1996	JP	2002-534003	10/2002
JP	08-214076	8/1996	JP	2002-537594	11/2002
JP	08-214346	8/1996	JP	2003-502720	1/2003
JP	08-510071	10/1996	JP	2003-507908	2/2003
JP	8-321885	12/1996	JP	2003-510929	3/2003
JP	8-329118	12/1996	JP	3384792 B2	3/2003
JP	8-331618	12/1996	JP	3393119 B2	4/2003
JP	09-036963	2/1997	JP	2003-516672	5/2003
JP	09-501812	2/1997	JP	3453561 B2	10/2003
JP	09-504394	4/1997	JP	3461488 B2	10/2003
JP	09-149137	6/1997	JP	3516656 B2	4/2004
JP	09-163031	6/1997	JP	3516659 B2	4/2004
JP	09-224093	8/1997	JP	3547142 B2	7/2004
JP	09-508508	8/1997	JP	3547397 B2	7/2004
JP	09-233118	9/1997	JP	2004-312730	11/2004
JP	09-265408	10/1997	JP	2005-504452	2/2005
JP	10-11374	1/1998	JP	3615708 B2	2/2005
JP	10-13811	1/1998	JP	3628962 B2	3/2005
JP	10-51549	2/1998	JP	2005-094780	4/2005
JP	10-093713	4/1998	JP	2005-102234	4/2005
JP	10-093716	4/1998	JP	2005-124184	5/2005
JP	10-504425	4/1998	JP	3681403 B2	8/2005
JP	10-116249	5/1998	JP	3681406 B2	8/2005
JP	10-143451	5/1998	JP	3686087 B2	8/2005
			JP	3686337 B2	8/2005
			JP	3735124 B2	1/2006
			JP	3820151	9/2006
			JP	2006-295947	10/2006
			JP	3877523 B2	2/2007

(56)

## References Cited

## FOREIGN PATENT DOCUMENTS

JP	4057785	B2	3/2008
JP	4205310	B2	1/2009
JP	4234926	B2	3/2009
JP	4295186	B2	7/2009
JP	4450515	B2	4/2010
JP	2012-513725		6/2012
KR	10-2011-0098841	A	9/2011
WO	9208194	A1	5/1992
WO	9401959	A1	1/1994
WO	9429995	A1	12/1994
WO	9508236	A2	3/1995
WO	9520860	A1	8/1995
WO	9533325	A2	12/1995
WO	9614704	A1	5/1996
WO	9620553	A2	7/1996
WO	9623265	A1	8/1996
WO	9627254	A1	9/1996
WO	9701917	A1	1/1997
WO	9712472	A1	4/1997
WO	9713352	A1	4/1997
WO	9716014	A2	5/1997
WO	9718662	A1	5/1997
WO	9720424	A1	6/1997
WO	9722201	A2	6/1997
WO	9723078	A1	6/1997
WO	9726749	A1	7/1997
WO	9728635	A1	8/1997
WO	9729584	A1	8/1997
WO	9734401	A1	9/1997
WO	9736414	A1	10/1997
WO	9737500	A1	10/1997
WO	9738389	A2	10/1997
WO	9738519	A1	10/1997
WO	9750235	A1	12/1997
WO	9801987	A1	1/1998
WO	9810573	A2	3/1998
WO	9813765	A1	4/1998
WO	9813974	A1	4/1998
WO	9817048	A1	4/1998
WO	9827479	A2	6/1998
WO	9831130	A1	7/1998
WO	9834390	A1	8/1998
WO	9835326	A1	8/1998
WO	9835509	A2	8/1998
WO	9836551	A1	8/1998
WO	9837481	A1	8/1998
WO	9837677	A2	8/1998
WO	9837686	A1	8/1998
WO	9837687	A1	8/1998
WO	9844699	A1	10/1998
WO	9844714	A1	10/1998
WO	9848577	A2	10/1998
WO	9854877	A2	12/1998
WO	9856133	A2	12/1998
WO	9856141	A1	12/1998
WO	9857501	A2	12/1998
WO	9900960	A1	1/1999
WO	9900966	A1	1/1999
WO	9903247	A2	1/1999
WO	9912367	A1	3/1999
WO	9913635	A1	3/1999
WO	9914919	A1	3/1999
WO	9914920	A1	3/1999
WO	9914924	A1	3/1999
WO	9914951	A1	3/1999
WO	9917518	A1	4/1999
WO	9923806	A1	5/1999
WO	9923807	A1	5/1999
WO	9926395	A1	5/1999
WO	9926424	A2	5/1999
WO	9927698	A1	6/1999
WO	9941720	A1	8/1999
WO	9941890	A2	8/1999
WO	9941891	A1	8/1999
WO	9941895	A1	8/1999
WO	9943137	A1	8/1999
WO	9925117		10/1999
WO	9956227	A1	11/1999
WO	9956229	A1	11/1999
WO	9965214	A1	12/1999
WO	9965252	A2	12/1999
WO	9967718	A1	12/1999
WO	0007332	A2	2/2000
WO	0016203	A1	3/2000
WO	0016207	A1	3/2000
WO	0016523	A1	3/2000
WO	0018094	A1	3/2000
WO	0025238	A1	5/2000
WO	0026804	A1	5/2000
WO	0026816	A1	5/2000
WO	0026817	A1	5/2000
WO	0027063	A2	5/2000
WO	0028425	A1	5/2000
WO	0028702	A1	5/2000
WO	0035173	A1	6/2000
WO	0038398	A1	6/2000
WO	0044159	A1	7/2000
WO	0049482	A2	8/2000
WO	0049778	A1	8/2000
WO	0113606	A1	2/2001
WO	0124025	A1	4/2001
WO	0140997	A1	6/2001
WO	0141372	A1	6/2001
WO	0143410	A1	6/2001
WO	0152513	A1	7/2001
WO	0180214	A1	10/2001
WO	0180540	A1	10/2001
WO	0184360	A1	11/2001
WO	02065741	A2	8/2002
WO	03010948	A1	2/2003
WO	2004063854	A2	7/2004
WO	2005036907	A1	4/2005
WO	2006055059	A2	5/2006
WO	2010075151	A1	7/2010

## OTHER PUBLICATIONS

“Guide for the Use of Micro-Researcher II/SGR (Scroll Graph Section),” NEC Corporation, Third Edition, Chapters 1 & 5, Jul. 1995, 2 pages.

“Kana: Customer Messaging System,” Kana Communications Sales Brochure, Palo Alto, CA, 1996, 12 pages.

“Latest Trend in CTI,” Nikkei Communications, No. 248, Jun. 16, 1997, 14 pages.

“Method for Automatic Contextual Transposition Upon Receipt of Item of Specified Criteria,” IBM Technical Disclosure Bulletin, vol. 37, No. 2B, Feb. 1994, 1 page.

“New Telephone Service Changing Computer Telephone Business,” Nikkei Communications, Nov. 11, 1996, 7 pages.

“Single Line Suffices for Internet Telephone,” Nikkei Communications, May 19, 1997, 9 pages.

Bachmann, David W. et al., “NetMod: A Design Tool for Large-Scale Heterogeneous Campus Networks,” Center for Information Technology Integration (CITI), the University of Michigan, Ann Arbor, MI, Jun. 15, 1990, 34 pages.

Bangun, H. et al., A Network Architecture for Multiuser Networked Games on Demand, International Conference on Information Communications and Signal Processing, ICICS '97, Sep. 9-12, 1997, 5 pages.

Bertsekas, Dimitri et al., “Data Networks,” Prentice-Hall, New Jersey, 1987, 5 pages.

Chau, Sam et al., “Intelligent Network Routing Using CCS7 and ISDN,” Global Telecommunications Conference, vol. 3, 6 pages, 1990.

Chaudhuri, Surajit et al., “Optimizing Queries over Multimedia Repositories,” Hewlett-Packard Laboratories, Stanford, Mar. 1996, 12 pages.

Chaum, David, “Untraceable Electronic Mail, Return Addresses, and Digital Pseudonyms,” Communications of the ACM, vol. 24, No. 2, Feb. 1981, 8 pages.

(56)

## References Cited

## OTHER PUBLICATIONS

- Chew, T.-S. et al., "Netplan-a Telecommunications Network Planning Support System," TENCON '92, IEEE Region 10 International Conference, vol. 2, 7 pages, 1992.
- Chiu, H. et al., "Conferencing Metaphor," IBM Technical Disclosure Bulletin, vol. 36, No. 2, Feb. 1993, 4 pages.
- Cordom, Christopher et al., "Conversant VIS Listens and Talks to Your Customers," AT&T Technology, vol. 9, No. 2, 4 pages, 1994.
- D'Hooge, Herman, "The Communicating PC," IEEE Communications Magazine, 6 pages, Apr. 1996.
- Durinovic-Johri, Sanja et al., "Advanced Routing Solutions for Toll-Free Customers: Algorithm Design and Performance," Proceedings of the International Teletraffic Congress, ITC-15, 1997, 12 pages.
- Esesve, D.R., "Wireless Application Protocol (WAP)," Vitam College of Engineering, No Date Available, 12 pages.
- Festa, Paul, "Vignette Updates StoryServer Platform," CNET News.com, Sep. 16, 1997, 4 pages.
- Foster, Robin Harris, "Advanced Definity Call Centers: Working for You and Your Customers," AT&T Technology, vol. 9, No. 2, 1994, 6 pages.
- Francis, Paul et al., "Flexible Routing and Addressing for a Next Generation IP," SIGCOMM, 10 pages, 1994.
- Gawrys, G.W., et al., "ISDN: Integrated Network/Premises Solutions for Customer Needs," ICC, 6 pages, 1986.
- Gechter, J. et al., "ISDN Service Opportunities in the Intelligent Network," Proceedings of the National Communications Forum, Chicago, IL, vol. 43, No. 1, Oct. 1989, 4 pages.
- Harvey, Dean E. et al., "Call Center Solutions," AT&T Technical Journal, vol. 70, No. 5, 10 pages, Sep./ Oct. 1991.
- Held, Gilbert, "Voice Over Data Networks," McGraw Hill, Texas, 1998, 16 pages.
- Henderson, Shane G. et al., "Rostering by Interating Integer Programming and Simulation," Proceedings of the 1998 Winter Simulation Conference, Washington D.C., Dec. 13, 1998, 7 pages.
- Hofmann, Peter. et al., "@INGate: Integrating Telephony and Internet," IEEE Conference on Protocols for Multimedia Systems, 4 pages, Nov. 1997.
- House, Eric, "How to Munge Outgoing From: Field When Using Mail?," Google Discussion Group, Apr. 2, 1997, 1 page.
- Hu, Michael Junke et al., "An Object-Relational Database System for the Interactive Multimedia," IEEE International Conference on Intelligent Processing Systems, pp. 1571-1575, Oct. 1997.
- International Search Report for PCT/US96/16919, dated Jun. 2, 1997, 3 pages.
- International Search Report for PCT/US97/01469, dated Apr. 14, 1997, 1 page.
- International Search Report for PCT/US97/05457, dated Jun. 24, 1997, 2 pages.
- International Search Report for PCT/US97/11881, dated Oct. 24, 1997, 1 page.
- Kaufman, Harvey, "Call Centers in Cyberspace," Communications News, vol. 34, Issue 7, Jul. 1997, 4 pages.
- Kramer, Brian, "How to Send a File to the Sender of a Message?," Google Discussion Group, May 27, 1994, 5 pages.
- Lee, Chien-I, et al., "A New Storage and Retrieval Method to Support Editing Operations in a Multi-Disk-based Video Server," Fourth International Conference on Parallel and Distributed Information Systems, IEEE, Miami Beach, FL, Dec. 1996, 10 pages.
- Lin, Yi-Bing et al., "A Flexible Graphical User Interface for Performance Modeling," Software—Practice and Experience, vol. 25(2), Feb. 1995, 24 pages.
- Low, Colin, "The Internet Telephony Red Herring," Global Telecommunications Conference, Nov. 1996, 15 pages.
- Mackay, Wendy E., et al., "Virtual Video Editing in Interactive Multimedia Applications," Communications of the ACM, vol. 32, No. 7, Jul. 1989, 9 pages.
- Masashi, Tsuboi et al., "Computer Telephony Integration System," CTSTAGE, Oki Electric Research and Development, 174, vol. 64, No. 2, Apr. 1, 1997, 10 pages.
- Matsuo, Yasunori, "Microsoft Project for Windows 95," Nikkei Personal Computing, Nikkei Business Publications, Inc., No. 255, Dec. 18, 1995, 2 pages.
- Mattison, Rob, "Data Warehousing and Data Mining for Telecommunications," Artech House, Boston, 1997, 7 pages.
- Metz, Christopher, "IP Routers: New Tool for Gigabit Networking," On the Wire, IEEE Internet, Nov./Dec. 1998, 5 pages.
- Microsoft Dictionary Pages, Microsoft Press, Redmond, WA, 1991, 2 pages.
- Orozco-Barbosa, Luis et al., "Design and Performance Evaluation of Intelligent Multimedia Services," Computer Communications, vol. 20, 1997, 14 pages.
- Padmanabhan, M., et al. Speech Recognition Performance on a Voicemail Transcription Task, IBM T.J. Watson Research Center, Yorktown Height, NY, 4 pages.
- Rangan, P. Venkat, et al., "A Window-Based Editor for Digital Video and Audio," Proceedings of the 25th Hawaii International Conference on System Sciences, IEEE, vol. 2, Jan. 1992, 9 pages.
- Recker, Mimi M. et al., "Predicting Document Access in Large, Multimedia Repositories," ACM Transactions on Computer-Human Interaction, vol. 3, 1994, 23 pages.
- Schmandt, Chris, "Phoneshell: The Telephone as Computer Terminal," Proceedings of ACM Multimedia Conference, 1993, 10 pages.
- Semilof, Margie, "Call Centers Go On-Line," Communications Week, No Date Available, 2 pages.
- Smith, J.D., An Overview to Computer-Telecommunications Integration (CTI), Telecommunications, Conference Publication No. 404, IEEE, Mar. 26-29, 1995, 5 pages.
- Sulkin, Allan, Building the ACD-LAN Connection, Business Communications Review, Jun. 1996, 4 pages.
- Szlam, Aleksander et al., "Predictive Dialing Fundamentals," Flatiron Publishing, New York, 1996, 28 pages.
- Toji, Ryutaro et al., "A Study of Customer Contact Operation System and Functions," Proceedings of the IECE General Conference, Comm. 2, Mar. 6, 1997, 3 pages.
- Tsunemasa, Mizuo., "CTI World 2: World of CTI," Business Communication, vol. 34, No. 2, Feb. 1, 1997, 13 pages.
- Van Zijl, Lynette, et al., "A Tool for Graphical Network Modeling and Analysis," IEEE Software, Jan. 1992, 8 pages.
- Vazquez, E., et al., Graphical Interface for Communication Network Analysis and Simulation, Department of Telematic Engineering, Technical University of Madrid, IEE, 1991, Spain, 4 pages.
- Zenel, Bruce et al., Intelligent Communication Filtering for Limited Bandwidth Environments, Computer Science Department, Columbia University, IEEE, 1995, 7 pages.
- "Solution Drivers/CTI, CTI Solution Strategy of Seven Computer Vendors, Toward Market Development of Mainly Bank, Insurance and Communications Markets," Computopia, Computer Age Co., Ltd., Japan, vol. 33, No. 379, 5 pages, Apr. 1998.
- Beck, C. et al., Interactive process of operating system for multimedia communication center, Genesys Telecom Lab, Inc. 2014, 3 pages.
- Bernett, Howard et al., "Assessing Web-Enabled Call Center Technologies," IT Pro, May/June 2001, 7 pages.
- Bickley, M. et al., Using Servers to Enhance Control System Capability, 1999 Particle Accelerator Conference, New York, NY, Mar. 29-Apr. 2, 1999, 3 pages.
- Bradley, Kirk A. et al., "Detecting Disruptive Routers: A Distributed Network Monitoring Approach," Department of Computer Science, University of California, Davis, Sep. 1, 1998, 10 pages.
- Canadian Office Action for Application No. 2,259,912, dated Nov. 19, 2001, 2 pages.
- Canadian Office Action for Application No. 2,289,198, dated Jun. 28, 2002, 2 pages.
- Canadian Office Action for Application No. 2,302,397, dated Apr. 23, 2002, 2 pages.
- Canadian Office Action for Application No. 2,302,678, dated Apr. 23, 2002, 2 pages.
- Canadian Office Action for Application No. 2308590, dated Jun. 28, 2002, 2 pages.
- Canadian Office Action for Application No. 2309183, dated Jul. 23, 2002, 2 pages.

(56)

**References Cited**

## OTHER PUBLICATIONS

- Canadian Office Action for Application No. 2320978, dated Jun. 2, 2003, 2 pages.
- Canadian Office Action for Application No. 2320978, dated Sep. 26, 2002, 2 pages.
- Canadian Office Action for Application No. 2334513, dated May 30, 2003, 2 pages.
- Canadian Office Action for Application No. 2347721, dated Aug. 12, 2004, 3 pages.
- Canadian Office Action for Application No. 2352973, dated Apr. 17, 2003, 3 pages.
- Chan, Kevin F. et al., "Interactive Network Planning and Analysis on a Personal Computer," Computer Applications in Power, IEEE, vol. 3, No. 1, Jan. 1990, 5 pages.
- Chinese Office Action for Application No. 200980151937.6, dated Jul. 1, 2013, 14 pages.
- Chinese Office Action for Application No. 98812258.8 dated Jul. 26, 2002, 5 pages.
- Chinese Office Action for Application No. 98812259.6, dated Jan. 10, 2003, 9 pages.
- Chinese Office Action for Application No. 98812261.8, dated Jun. 20, 2003, 10 pages.
- Chinese Office Action for Application No. 99808531.6, dated Mar. 14, 2003, 14 pages.
- Chinese Office Action for Application No. 99811995.4, dated Apr. 8, 2005, 6 pages.
- Chinese Office Action for Application No. 99811995.4, dated Jul. 6, 2007, 11 pages.
- Chinese Office Action for Application No. 99811996.2, dated May 9, 2003, 10 pages.
- Chinese Office action for Patent Application No. 200980151937.6, dated Feb. 15, 2015, 6 pages.
- Chinese Office action with English Translation for Application No. 200980151937.6 dated May 23, 2014, 7 pages.
- Chou, Sheng-Lin., et al., "Computer Telephony Integration and Its Applications," IEEE Communications Surveys & Tutorials, vol. 3, No. 1, 2000, 10 pages.
- Curbera, Francisco et al., "Unraveling the Web Services Web: An Introduction to SOAP, WSDL, and UDDI," IEEE Internet Computing, 8 pages, Mar./Apr. 2002.
- Eren, P. Erhan, et al., "Interactive Object-Based Analysis and Manipulation of Digital Video," IEEE Workshop on Multimedia Signal Processing, 1998, 6 pages.
- European Office action Application No. 04011886.1, dated Mar. 9, 2007, 6 pages.
- European Office action for Application No. 00115441.8, dated Feb. 11, 2004, 7 pages.
- European Office action for Application No. 00115441.8, dated Mar. 15, 2005, 4 pages.
- European Office Action for Application No. 00115441.8, dated May 18, 2006, 11 pages.
- European Office Action for Application No. 00119160.0, dated Jan. 16, 2004, 6 pages.
- European Office action for Application No. 00123329.5, dated Jun. 17, 2002, 6 pages.
- European Office Action for Application No. 00123331.1, dated Apr. 18, 2006, 5 pages.
- European Office Action for Application No. 00305049.9, dated Dec. 29, 2003, 5 pages.
- European Office Action for Application No. 00908266.0, dated Aug. 10, 2005, 6 pages.
- European Office action for Application No. 02400027.5, dated Jan. 21, 2008, 5 pages.
- European Office action for Application No. 02756535.7, dated Aug. 5, 2005, 6 pages.
- European Office Action for Application No. 03022831.6, dated Nov. 30, 2006, 7 pages.
- European Office Action for Application No. 03800376.0, dated Jul. 8, 2008, 6 pages.
- European Office Action for Application No. 04009176.1, dated Oct. 12, 2011, 8 pages.
- European Office Action for Application No. 97904087.0, dated Jun. 25, 2002, 5 pages.
- European Office Action for Application No. 97933327.5, dated Aug. 26, 2002, 4 pages.
- European Office Action for Application No. 97933327.5, dated Feb. 7, 2002, 5 pages.
- European Office Action for Application No. 98903471.5, dated May 29, 2006, 4 pages.
- European Office Action for Application No. 98903471.5, dated Oct. 11, 2004, 6 pages.
- European Office Action for Application No. 98908545.1, dated Mar. 15, 2005, 4 pages.
- European Office Action for Application No. 98908545.1, dated Nov. 14, 2003, 10 pages.
- European Office Action for Application No. 98924821.6, dated Aug. 26, 2003, 4 pages.
- European Office Action for Application No. 98926248.0, dated Aug. 5, 2004, 4 pages.
- European Office Action for Application No. 98926248.0, dated Dec. 11, 2003, 4 pages.
- European Office Action for Application No. 98926248.0, dated Oct. 21, 2002, 6 pages.
- European Office Action for Application No. 98944799.0, dated Aug. 18, 2005, 7 pages.
- European Office Action for Application No. 98944799.0, dated Mar. 26, 2008, 5 pages.
- European Office Action for Application No. 98944830.3, dated Jan. 30, 2006, 9 pages.
- European Office Action for Application No. 98946907.7, dated Jun. 1, 2006, 6 pages.
- European Office Action for Application No. 98946926.7, dated Dec. 8, 2005, 4 pages.
- European Office Action for Application No. 98953947.3, dated Aug. 22, 2006, 6 pages.
- European Office Action for Application No. 98953962.2, dated Oct. 28, 2005, 5 pages.
- European Office Action for Application No. 98956309.3, dated Jun. 8, 2005, 5 pages.
- European Office Action for Application No. 99905907.4, dated Oct. 31, 2005, 4 pages.
- European Office Action for Application No. 99906856.2, dated Sep. 24, 2007, 5 pages.
- European Office Action for Application No. 99906958.6, dated Feb. 22, 2006, 7 pages.
- European Office Action for Application No. 99927333.7, dated Aug. 21, 2006, 9 pages.
- European Office Action for Application No. 99927340.2, dated Aug. 9, 2011, 6 pages.
- European Office Action for Application No. 99927340.2, dated Nov. 25, 2013, 5 pages.
- European Office Action for Application No. 99945479.6, dated Aug. 9, 2006, 6 pages.
- European Office Action for Application No. 99945519.9, dated Aug. 20, 2007, 6 pages.
- European Office action for Application No. 99956732.4, dated Aug. 17, 2006, 7 pages.
- European Office action for Application No. 99956745.6, dated Mar. 14, 2006, 5 pages.
- European Office Action for Application No. 99960267.5, dated May 10, 2007, 6 pages.
- European Office Action for Application No. 99960279.0, dated Aug. 16, 2005, 6 pages.
- European Office Action for Application No. 99965163.1, dated Jul. 13, 2009, 5 pages.
- European Search Report and Written Opinion for Application No. 05783002.8, dated Mar. 16, 2009, 8 pages.
- European Search Report for 0115441.8 (now EP1075153), dated Nov. 6, 2002, 3 pages.
- European Search Report for Application No. 00123329.5, dated Jan. 30, 2002, 2 pages.

(56)

**References Cited**

## OTHER PUBLICATIONS

European Search Report for Application No. 00123331.1, dated Dec. 5, 2003, 6 pages.

European Search Report for Application No. 00305049.9, dated May 7, 2003, 3 pages.

European Search Report for Application No. 00908266.0, dated May 24, 2005, 3 pages.

European Search Report for Application No. 00913226.7, dated Feb. 14, 2005, 3 pages.

European Search Report for Application No. 0119160.0, dated Apr. 17, 2003, 3 pages.

European Search Report for Application No. 01920248.0, dated May 3, 2004, 3 pages.

European Search Report for Application No. 01927387.9, dated Jun. 2, 2006, 3 pages.

European Search Report for Application No. 02400027.5, dated Feb. 20, 2004, 3 pages.

European Search Report for Application No. 02756535.7, dated May 25, 2005, 4 pages.

European Search Report for Application No. 03002575.3, dated Jun. 4, 2003, 3 pages.

European Search Report for Application No. 03008532.8, dated Dec. 27, 2004, 3 pages.

European Search Report for Application No. 03008534.4, dated Jul. 23, 2003, 3 pages.

European Search Report for Application No. 03022831.6, dated Mar. 22, 2006, 3 pages.

European Search Report for Application No. 03023463.7, dated Jun. 14, 2004, 3 pages.

European Search Report for Application No. 03076826.1, dated Sep. 10, 2003, 3 pages.

European Search Report for Application No. 03077174.5, dated Sep. 4, 2003, 4 pages.

European Search Report for Application No. 03077712.2, dated Mar. 29, 2004, 3 pages.

European Search Report for Application No. 03800376, dated May 7, 2007, 3 pages.

European Search Report for Application No. 04007911.3, dated Aug. 17, 2004, 5 pages.

European Search Report for Application No. 04007913.9, dated Aug. 5, 2004, 4 pages.

European Search Report for Application No. 04011886.1, dated Jun. 22, 2006, 5 pages.

European Search Report for Application No. 07018035.1, dated Apr. 23, 2009, 4 pages.

European Search Report for Application No. 97904087.0, dated Nov. 5, 2001, 3 pages.

European Search Report for Application No. 97933327.5, dated Oct. 11, 2001, 3 pages.

European Search Report for Application No. 98903471.5, dated Jul. 26, 2002, 4 pages.

European Search Report for Application No. 98903623.1, dated Apr. 17, 2002, 3 pages.

European Search Report for Application No. 98907371.3, dated Mar. 28, 2002, 3 pages.

European Search Report for Application No. 98924821.6, dated Jun. 13, 2002, 2 pages.

European Search Report for Application No. 98926248, dated Jul. 18, 2002, 3 pages.

European Search Report for Application No. 98944799.0, dated Aug. 5, 2004, 3 pages.

European Search Report for Application No. 98944830.3, dated Aug. 11, 2004, 3 pages.

European Search Report for Application No. 98946907.7, dated Aug. 11, 2004, 3 pages.

European Search Report for Application No. 98946926.7, dated Aug. 11, 2004, 3 pages.

European Search Report for Application No. 98948163.5, dated Aug. 8, 2000, 3 pages.

European Search Report for Application No. 98948164.3, dated Jun. 15, 2004, 3 pages.

European Search Report for Application No. 98953947.3, dated Aug. 20, 2004, 3 pages.

European Search Report for Application No. 98953962.2, dated Sep. 2, 2004, 3 pages.

European Search Report for Application No. 98956187.3, dated Sep. 16, 2005, 3 pages.

European Search Report for Application No. 98956309.3, dated Sep. 10, 2004, 3 pages.

European Search Report for Application No. 99905907.4, dated Jun. 1, 2005, 3 pages.

European Search Report for Application No. 99906856.2, dated Oct. 4, 2006, 3 pages.

European Search Report for Application No. 99906958.6, dated Aug. 19, 2005, 3 pages.

European Search Report for Application No. 99927333.7, dated Mar. 30, 2005, 5 pages.

European Search Report for Application No. 99927340.2, dated Oct. 18, 2004, 3 pages.

European Search Report for Application No. 99945479.6, dated Mar. 24, 2006, 3 pages.

European Search Report for Application No. 99945519.9, dated Oct. 18, 2005, 3 pages.

European Search Report for Application No. 99945556.1, dated Nov. 16, 2004, 3 pages.

European Search Report for Application No. 99956732.4, dated Apr. 19, 2006, 4 pages.

European Search Report for Application No. 99956745.6, dated Jun. 30, 2005, 3 pages.

European Search Report for Application No. 99960267.5, dated Jul. 14, 2005, 3 pages.

European Search Report for Application No. 99960279.0, dated Apr. 26, 2005, 3 pages.

European Search Report for Application No. 99965163.1, dated Nov. 19, 2004, 4 pages.

European Search Report for Application No. 99971602.0, dated Feb. 6, 2007, 3 pages.

International Preliminary Examination Report for PCT/US01/13313, dated Apr. 22, 2002, 4 pages.

International Preliminary Examination Report for PCT/US01/40267, dated Dec. 9, 2002, 4 pages.

International Preliminary Examination Report for PCT/US96/16919, dated Feb. 18, 1998, 18 pages.

International Preliminary Examination Report for PCT/US97/01469, dated Oct. 14, 1998, 8 pages.

International Preliminary Examination Report for PCT/US97/11881, dated Mar. 27, 1998, 3 pages.

International Preliminary Examination Report for PCT/US98/00631, dated Sep. 10, 1999, 7 pages.

International Preliminary Examination Report for PCT/US98/02847, dated Jul. 9, 1999, 5 pages.

International Preliminary Examination Report for PCT/US98/13644, dated Jan. 12, 2000, 6 pages.

International Preliminary Examination Report for PCT/US98/18646, dated Oct. 30, 2000, 5 pages.

International Preliminary Examination Report for PCT/US98/18789, dated Dec. 30, 1999, 6 pages.

International Preliminary Examination Report for PCT/US98/22527, dated Jun. 30, 2000, 5 pages.

International Preliminary Examination Report for PCT/US99/12841, dated Jan. 22, 2001, 5 pages.

International Preliminary Examination Report for PCT/US99/25308, dated Sep. 10, 2000, 3 pages.

International Preliminary Examination Report for PCT/US99/25309, dated May 8, 2001, 4 pages.

International Preliminary Report on Patentability for PCT/US2005/027544, dated May 22, 2007, 7 pages.

International Search Report and Written Opinion for PCT/US2009/068402, dated Mar. 31, 2010, 10 pages.

International Search Report for PCT/US00/00781, dated Apr. 12, 2000, 2 pages.



(56)

**References Cited**

## OTHER PUBLICATIONS

- International Search Report for PCT/US00/00785, dated Oct. 2, 2000, 2 pages.
- International Search Report for PCT/US00/023066, dated Oct. 30, 2000, 1 page.
- International Search Report for PCT/US00/27982, dated Jan. 31, 2001, 3 pages.
- International Search Report for PCT/US00/27983, dated Mar. 19, 2001, 2 pages.
- International Search Report for PCT/US00/27984, dated Mar. 22, 2001, 1 page.
- International Search Report for PCT/US01/07457, dated Aug. 30, 2001, 1 page.
- International Search Report for PCT/US01/13313, dated Jul. 6, 2001, 1 page.
- International Search Report for PCT/US01/40267, dated Jul. 17, 2001, 1 page.
- International Search Report for PCT/US02/23080, dated Oct. 1, 2002, 1 page.
- International Search Report for PCT/US03/41677, dated Apr. 10, 2006, 1 page.
- International Search Report for PCT/US05/27544, dated Jun. 14, 2006, 1 page.
- International Search Report for PCT/US98/00631, dated Jun. 18, 1998, 1 page.
- International Search Report for PCT/US98/01158, dated Jul. 17, 1998, 1 page.
- International Search Report for PCT/US98/02152, dated Jun. 25, 1998, 1 page.
- International Search Report for PCT/US98/02847, dated Aug. 6, 1998, 1 page.
- International Search Report for PCT/US98/02848, dated Aug. 11, 1998, 1 page.
- International Search Report for PCT/US98/02923, dated Aug. 19, 1998, 1 page.
- International Search Report for PCT/US98/06334, dated Sep. 1, 1998, 2 pages.
- International Search Report for PCT/US98/10357, dated Jan. 14, 1999, 1 page.
- International Search Report for PCT/US98/11442, dated Oct. 21, 1998, 2 pages.
- International Search Report for PCT/US98/13644, dated Apr. 21, 1999, 2 pages.
- International Search Report for PCT/US98/18646, dated Jan. 29, 1999, 2 pages.
- International Search Report for PCT/US98/18789, dated Jan. 29, 1999, 3 pages.
- International Search Report for PCT/US98/18833, dated Nov. 19, 1998, 1 page.
- International Search Report for PCT/US98/18874, dated Jan. 29, 1999, 1 page.
- International Search Report for PCT/US98/18989, dated Jan. 25, 1999, 1 page.
- International Search Report for PCT/US98/22527, dated Apr. 2, 1999, 2 pages.
- International Search Report for PCT/US98/22555, mailed Mar. 3, 1999, 1 page.
- International Search Report for PCT/US98/22600, mailed Jun. 4, 1999, 1 page.
- International Search Report for PCT/US98/22935, mailed Apr. 14, 1999, 1 page.
- International Search Report for PCT/US99/02812, mailed May 11, 1999, 1 page.
- International Search Report for PCT/US99/02814, mailed Jun. 17, 1999, 1 page.
- International Search Report for PCT/US99/02822, mailed Aug. 18, 1999, 1 page.
- International Search Report for PCT/US99/03038, mailed Apr. 23, 1999, 1 page.
- International Search Report for PCT/US99/03039, mailed May 11, 1999, 1 page.
- International Search Report for PCT/US99/12700, dated Nov. 30, 1999, 1 page.
- International Search Report for PCT/US99/12781, dated Sep. 9, 1999, 2 pages.
- International Search Report for PCT/US99/12841, dated Sep. 10, 1999, 2 pages.
- International Search Report for PCT/US99/20259, dated Feb. 15, 2000, 1 page.
- International Search Report for PCT/US99/20387, dated Dec. 7, 1999, 2 pages.
- International Search Report for PCT/US99/20461, dated Dec. 23, 1999, 2 pages.
- International Search Report for PCT/US99/25117, dated Nov. 1, 2000, 2 pages.
- International Search Report for PCT/US99/25265, dated Feb. 18, 2000, 1 page.
- International Search Report for PCT/US99/25308, dated Feb. 3, 2000, 1 page.
- International Search Report for PCT/US99/25309, dated Feb. 10, 2000, 1 page.
- International Search Report for PCT/US99/25310, dated Feb. 10, 2000, 1 page.
- International Search Report for PCT/US99/26619, dated Mar. 17, 2000, 1 page.
- International Search Report for PCT/US99/26659, dated Feb. 4, 2000, 1 page.
- International Search Report for PCT/US99/29043, dated Mar. 20, 2000, 1 page.
- International Search Report for PCT/US99/29044, dated May 11, 2000, 1 page.
- International Written Opinion for PCT/US98/22527, dated Dec. 27, 1999, 5 pages.
- Japanese Interrogation and Re-Examination Report for Application No. 1999-502827, dated Oct. 26, 2004, 7 pages.
- Japanese Office Action for Application No. 1997-527811, dated Oct. 10, 2000, 6 pages.
- Japanese Office Action for Application No. 1998-505335, dated Mar. 5, 2002, 7 pages.
- Japanese Office Action for Application No. 1998-531244, dated Jan. 6, 2004, 4 pages.
- Japanese Office Action for Application No. 1998-531244, dated Sep. 10, 2002, 5 pages.
- Japanese Office Action for Application No. 1998-536740, dated Feb. 24, 2004, 5 pages.
- Japanese Office Action for Application No. 1998-536740, dated Sep. 3, 2002, 14 pages.
- Japanese Office Action for Application No. 1999-500765, dated Feb. 10, 2004, 6 pages.
- Japanese Office Action for Application No. 1999-500765, dated Sep. 3, 2002, 11 pages.
- Japanese Office Action for Application No. 1999-502827, dated Dec. 3, 2002, 4 pages.
- Japanese Office Action for Application No. 1999-502827, dated May 28, 2002, 3 pages.
- Japanese Office Action for Application No. 1999-502827, dated Nov. 1, 2005, 8 pages.
- Japanese Office action for Application No. 2000-220082, dated Apr. 1, 2003, 3 pages.
- Japanese Office Action for Application No. 2000-511299, dated Feb. 3, 2004, 4 pages.
- Japanese Office Action for Application No. 2000-511299, dated May 16, 2006, 7 pages.
- Japanese Office Action for Application No. 2000-512333, dated Sep. 3, 2002, 6 pages.
- Japanese Office Action for Application No. 2000-512334, dated Sep. 10, 2002, 9 pages.
- Japanese Office Action for Application No. 2000-512336, dated Jul. 23, 2002, 8 pages.
- Japanese Office Action for Application No. 2000-512336, dated Jun. 24, 2003, 4 pages.

(56)

**References Cited**

## OTHER PUBLICATIONS

- Japanese Office Action for Application No. 2000-514448, dated Sep. 3, 2002, 10 pages.
- Japanese Office Action for Application No. 2000-519541, dated May 16, 2005, 4 pages.
- Japanese Office Action for Application No. 2000-519541, dated Aug. 20, 2002, 10 pages.
- Japanese Office Action for Application No. 2000-519541, dated Dec. 2, 2003, 7 pages.
- Japanese Office Action for Application No. 2000-519541, dated Mar. 14, 2006, 6 pages.
- Japanese Office Action for Application No. 2000-522718, dated Sep. 10, 2002, 9 pages.
- Japanese Office Action for Application No. 2000-531822, dated Sep. 24, 2002, 6 pages.
- Japanese Office Action for Application No. 2000-531940, dated Dec. 3, 2002, 4 pages.
- Japanese Office Action for Application No. 2000-532958, dated Aug. 20, 2002, 7 pages.
- Japanese Office Action for Application No. 2000-554115, dated Apr. 27, 2005, 5 pages.
- Japanese Office Action for Application No. 2000-554115, dated Jan. 6, 2004, 4 pages.
- Japanese Office Action for Application No. 2000-554115, dated Oct. 1, 2002, 5 pages.
- Japanese Office Action for Application No. 2000-556311, dated Oct. 21, 2003, 6 pages.
- Japanese Office Action for Application No. 2000-570673, dated Oct. 4, 2005, 4 pages.
- Japanese Office Action for Application No. 2000-570673, dated Mar. 8, 2005, 6 pages.
- Japanese Office Action for Application No. 2000-570673, dated Oct. 14, 2003, 6 pages.
- Japanese Office Action for Application No. 2000-570677, dated May 11, 2004, 8 pages.
- Japanese Office Action for Application No. 2000-570677, dated Nov. 30, 2004, 10 pages.
- Japanese Office Action for Application No. 2000-570941, dated Oct. 7, 2003, 6 pages.
- Japanese Office Action for Application. No. 2000-578753, dated May 11, 2004, 11 pages.
- Japanese Office Action for Application No. 2000-580124, dated Apr. 12, 2005, 6 pages.
- Japanese Office Action for Application No. 2000-580124, dated Oct. 7, 2003, 5 pages.
- Japanese Office Action for Application No. 2000-580329, dated Feb. 15, 2005, 8 pages.
- Japanese Office Action for Application No. 2000-580329, dated May 13, 2008, 8 pages.
- Japanese Office Action for Application No. 2000-580329, dated Oct. 4, 2005, 5 pages.
- Japanese Office Action for Application No. 2000-581781, dated Feb. 3, 2004, 4 pages.
- Japanese Office Action for Application No. 2000-581781, dated Oct. 8, 2002, 4 pages.
- Japanese Office Action for Application No. 2000-590363, dated Apr. 1, 2003, 6 pages.
- Japanese Office Action for Application No. 2001-526724, dated Aug. 1, 2006, 5 pages.
- Japanese Office Action for Application No. 2001-526724, dated Dec. 13, 2005, 5 pages.
- Japanese Office Action for Application No. 2001-526724, dated May 17, 2005, 4 pages.
- Japanese Office Action for Application No. 2006-127262, dated Jun. 1, 2010 (5 pages).
- Japanese Office Action for Application No. 2006-127262, dated Nov. 18, 2008 (7 pages).
- Japanese Office Action for Application No. 2011-543586, dated Jan. 24, 2013, 5 pages.
- Japanese Office Action for Application No. 532950, dated Dec. 17, 2002, 6 pages.
- Katz, Michael, "When CTI Meets the Internet," *Telecommunications*, vol. 31, No. 7, Jul. 1997, 6 pages.
- Kaukonen, S., et al., "Agent-Based Conferencing Using Mobile IP-Telephony," *Proceedings of Multimedia Signal Processing*, 1999, 6 pages.
- Korean Office Action for Application No. 10-2011-7016735, dated Jun. 13, 2013, 3 pages.
- Korean Office Action for Application No. 10-2011-7017067, dated Aug. 21, 2012, 9 pages.
- Malabocchia, Fabio, et al., "Mining Telecommunications Data Bases: An Approach to Support the Business Management," *Network Operations and Management Symposium, IEEE*, vol. 1, Feb. 1998, 9 pages.
- Matsumoto, Akihiko, "Bank CTI/Call Center Using Up Customer Information, Analysis of Six Major Manufacturers' Solutions," *Network Computing, Ric Telecom Corporation, Japan*, vol. 10, No. 10, Oct. 1, 1998, 13 pages.
- Monson-Haefel, Richard, "Enterprise JavaBeans," *O'Reilly & Assoc.*, 2nd Ed., 1999, 7 pages.
- Murayama, Hideki, "Integrated Customer Supporting System View Workshop/CS, OA Business Personal Computer," *NEC Business System, Denpa Press Co., Ltd.*, vol. 15, No. 12, Dec. 1997, 6 pages.
- Nariani, Sushil, "Internet Telephony," *Whatis.com*, Oct. 25, 1999, 2 pages.
- Newton's Telecom Dictionary, *The Official Dictionary of Telecommunications & the Internet*, 16th Edition, *Telecom Books*, Feb. 2000, 3 pages.
- Newton, Harry, "Newton's Telecom Dictionary," *Flatiron Publishing, New York*, 1994, 7 pages.
- Rodriguez-Martinez, Manuel et al., "Mocha: A Self-Extensible Database Middleware System for Distributed Data Sources," *International Conference on Management Data—SIGMOD*, 2000, 12 pages.
- Rosenberg, Arthur M., "Call Center Computer Telephony: Technology Overview," *Gartner, Inc.*, Jan. 1998 (24 pages).
- Sekine, Shoji et al., "Front Office Oriented Solution for Customer Satisfaction and Profit Expansion," *Hitachi Hyoron Co, Ltd., Japan*, vol. 80, No. 9, Sep. 1998, 11 pages.
- Sevcik, Peter et al., "The Call Center Revolution," *Northeast Consulting Technical Paper*, Jan. 1, 1997, 12 pages.
- Supplemental European Search Report for Application No. 98908545.1, dated Sep. 5, 2002, 4 pages.
- T-Server for Alcatel A4400/OXE, *Deployment Guide, Framework 7.6, Genesys An Alcatel-Lucent Company*, 6 pages.
- Tadamura, Katsumi et al., "Synchronizing Computer Graphics Animation and Audio," *IEEE*, 1998, 11 pages.
- Taisei, Mori et al., "Call Center: Promotion of Information Use with a Direct Link to Core Business with Eye on the Internet Customer," *Ric Telecom Corporation, Japan*, vol. 10, No. 8, Aug. 1, 1998, 9 pages.
- Tang, Jingrong et al., "Advanced Service Architecture for H.323 Internet Protocol Telephony," *Computer Communications*, vol. 23, 2000, 14 pages.
- Thio, Fu Wang et al., "Distributed Multimedia Database: A Design and Application Study," *The Fourth International Conference on High Performance Computing in the Asia-Pacific Region, IEEE, Beijing, China*, vol. 2, May 2000, 6 pages.
- Toji, Ryutaro et al., "OCN Multimedia Customer Contact System," *NTT Technical Journal, The Telecommunication Association, Japan*, vol. 10, No. 1, Jan. 1, 1998, 6 pages.
- Wagner, Susanne., "Intralingual Speech-to-Text Conversion in Real-Time: Challenges and Opportunities," *Challenges of Multidimensional Translation Conference Proceedings*, 2005, 10 pages.
- Wang, Yong et al., "Real-time scheduling for multi-agent call center automation", *Information service agents lab, school of computing science Simon Fraser University, Burnaby, BC Canada*, 1999, 13 pages.
- Wolter, Roger., "XML Web Services Basics," *Microsoft Corporation*, Dec. 2001, 4 pages.
- Derfler, Frank J. et al., *How Networks Work*, *Que Corporation, Millennium Ed.*, 39 pages.

(56)

**References Cited**

OTHER PUBLICATIONS

Solis, Ignacio et al., FLIP: a Flexible Protocol for Efficient Communication Between Heterogeneous Devices, IEEE, 2001, 10 pages.

White, Ron, How Computers Work, Que Corporation, 7th Edition, Oct. 15, 2003, 53 pages.

\* cited by examiner

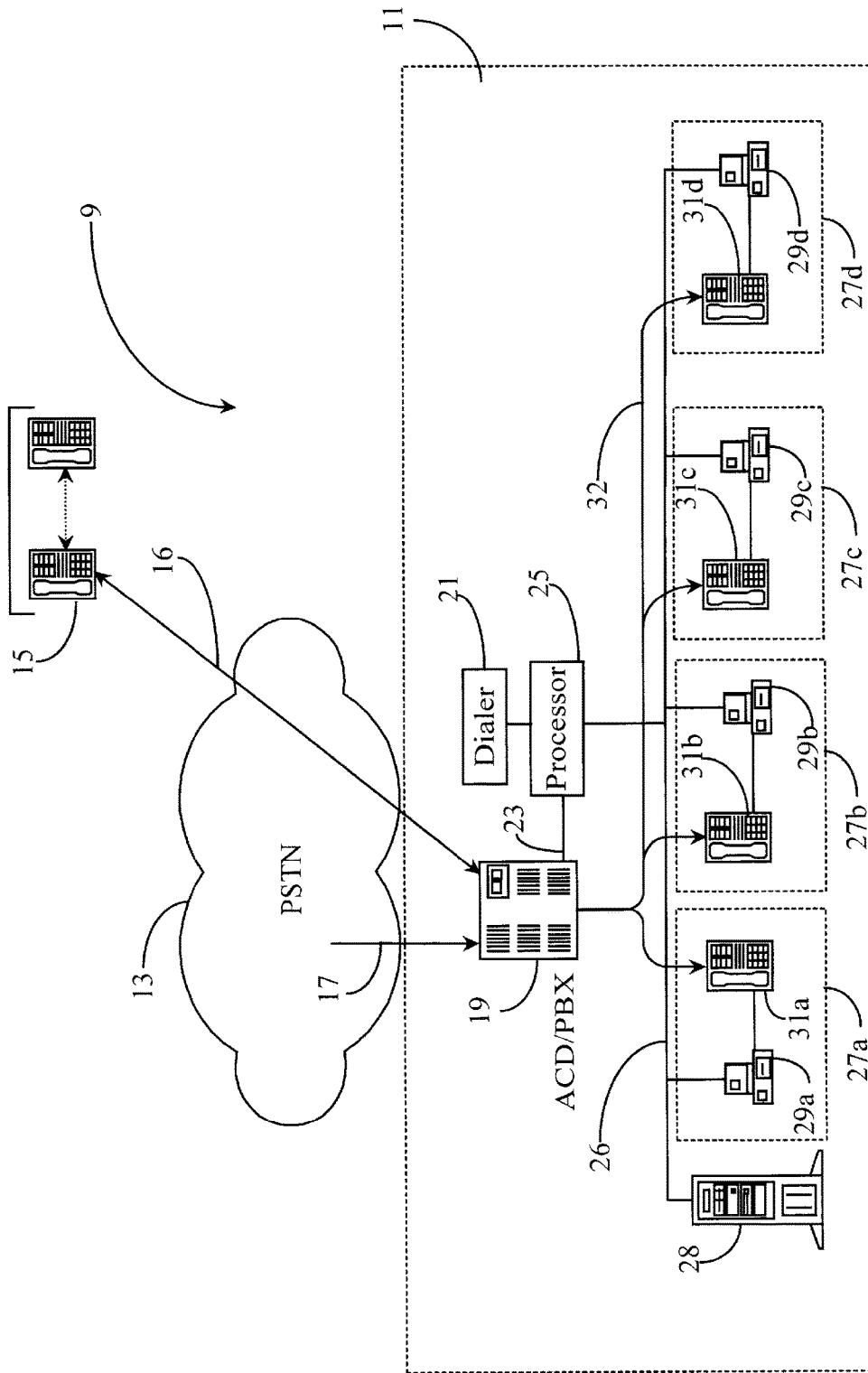

Fig. 1 (Prior Art)

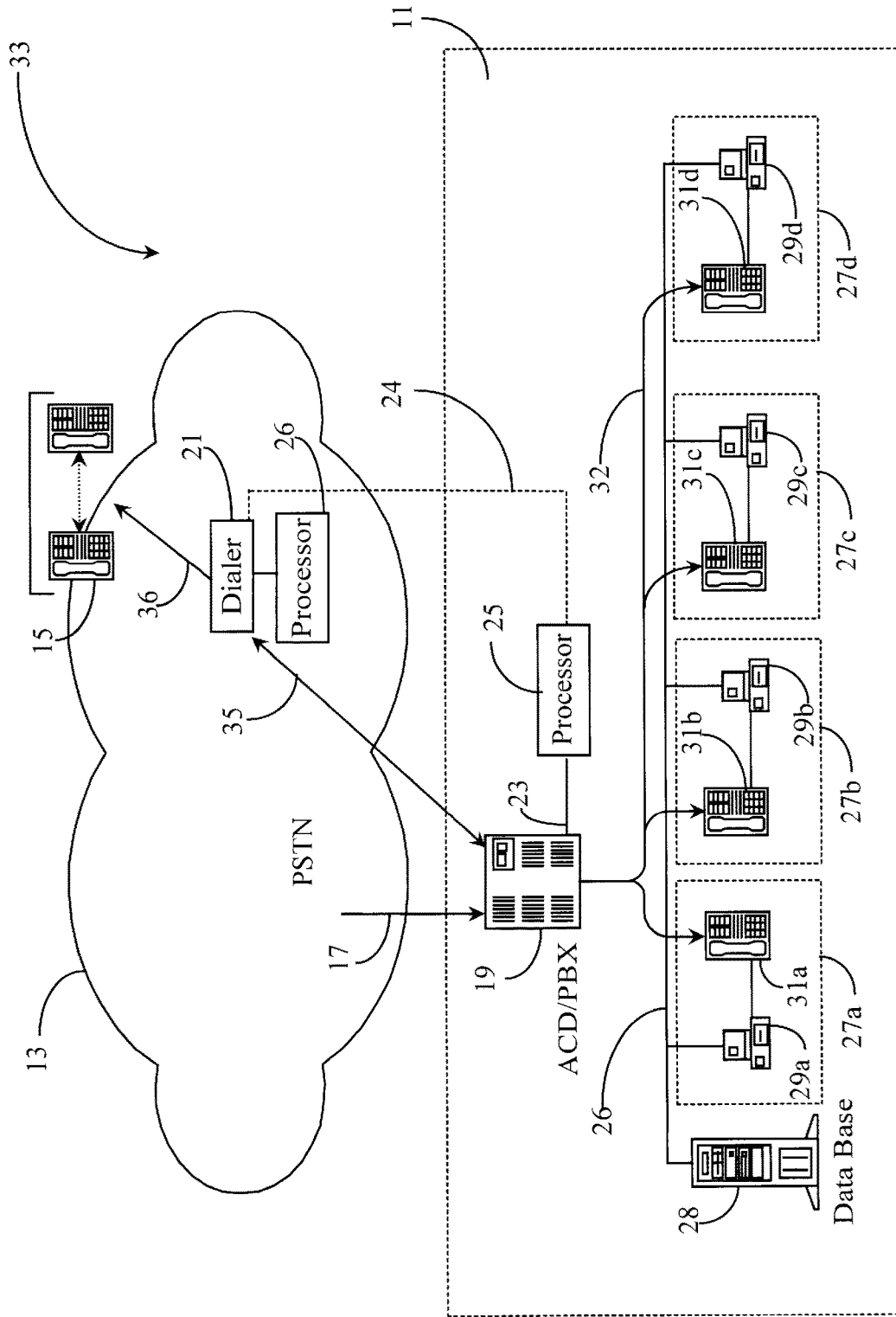

Fig. 2

**IMPLEMENTATION OF CALL-CENTER  
OUTBOUND DIALING CAPABILITY AT A  
TELEPHONY NETWORK LEVEL**

**Matter enclosed in heavy brackets [ ] appears in the original patent but forms no part of this reissue specification; matter printed in italics indicates the additions made by reissue; a claim printed with strikethrough indicates that the claim was canceled, disclaimed, or held invalid by a prior post-patent action or proceeding.**

CROSS-REFERENCE TO RELATED  
DOCUMENTS

[The present invention is related as a] *This application is a reissue of U.S. Pat. No. 5,991,395, filed Jun. 10, 1998 as application Ser. No. 09/095,732, which is a Continuation-in-Part [(CIP) to copending application 08/964,309, filed Nov. 4, 1997, and also as a CIP to copending] of application Ser. No. 08/968,825, filed Nov. 14, 1997.*

FIELD OF THE INVENTION

The present Invention is in the field of telecommunications and pertains more particularly to methods of implementing out bound dialing capability for a call center.

BACKGROUND OF THE INVENTION

Telephone call processing and switching systems are, at the time of the present patent application, relatively sophisticated, computerized systems, and development and introduction of new systems continues. Much information on the nature of such hardware and software is available in a number of publications accessible to the present inventors and to those with skill in the art in general. For this reason, much minute detail of known systems is not reproduced here, as to do so may obscure the facts of the invention.

At the time of filing the present patent application there continues to be remarkable growth in telephone-based information systems. Recently emerging examples are telemarketing operations and technical support operations, among many others, which have grown apace with development and marketing of, for example, sophisticated computer equipment. More traditional are systems for serving customers of large insurance companies and the like. In some cases organizations develop and maintain their own telephony operations with purchased or leased equipment, and in many other cases, companies are outsourcing such operations to firms that specialize in such services.

A large technical support operation serves as a good example in this specification of the kind of applications of telephone equipment and functions to which the present invention pertains and applies, and a technical support organization will be used from time to time in the current specification for example purposes. Such a technical support system, as well as other such systems, typically has a country-wide or even world-wide matrix of call centers for serving customer's needs. Such call center operations are more and more a common practice to provide redundancy and decentralization. However, the components of the present specification can apply to a single call center as well.

In a call center, a relatively large number of agents handle telephone communication with callers. Each agent is typically assigned to a telephone connected to a central switch, which is in turn connected by one or more trunk lines to a

publicly-switched telephone network (PSTN), well-known in the art. The central switch may be one of several types, as known in the art.

An organization having one or more call centers for serving customers typically provides one or more telephone numbers to the public or to their customer base, or both, that may be used to reach the service. The number or numbers may be published on product packaging, in advertisements, in user manuals, in computerized help files, and the like. There are basically two scenarios. If the organization providing the service has a single call center, the number will be to the call center, and all further routing to an agent will be at the call center. If there are several call centers, the organization may provide several numbers, one for each call center, and the customer may be expected to use the number for the closest center, or for the center advertised to provide specifically the service he or she might need. In some cases the number provided will connect the caller with a first Service Control Point (SCP) which is adapted to pre-process incoming calls and forward the calls to other call centers.

Routing of calls, then, may be on several levels. Pre-routing may be done at SCPs and further routing may be, and almost always is, accomplished at individual call centers. As described above, a call center typically involves a central switch, which may be, for example, an Automatic Call Distributor (ACD), Private Branch Exchange (PBX), or a public-switched telephone network (PSTN) switch. The central switch is connected to the PSTN network, well-known in the art. Agents, trained (hopefully) to handle customer service, man telephones connected to the central switch. This arrangement is known in the art as Customer Premises Equipment (CPE).

The processes of incorporating computer enhancement to telephone switches is known in the art as Computer Telephony Integration (CTI), and the hardware used is referred to as CTI equipment. Such equipment includes processors, routers, servers and the like. It is this processor that provides the CTI enhancement for the call center.

More recently, call centers have been enabled to handle data network telephony (DNT). DNT equipped centers operate similarly to conventional CIT centers in function although the operations such as routing calls, switching lines, queuing calls, and so on, are performed digitally with digital equipment rather than with an analog requirement. In DNT, calls are received at each agent's computer terminal or DNT communication device. For the purpose of this specification, a CTI system will most often be referred to when describing elements of the present invention although they will apply to DNT as well.

In a CTI system telephone stations connected to the central switch may be equipped also with computer terminals, so agents manning such stations may have access to stored data as well as being linked to incoming callers by a telephone connection. Such stations may be interconnected in a network by any one of several known network protocols, with one or more servers also connected to the network one or more of which may also be connected to a processor providing CTI enhancement, also connected to the central switch of the call center.

Typically, call centers are manned by agents connected by telephone and trained to handle certain problems experienced by customers such as questions regarding complicated installations of software and so on. Another instance might be a large sales network wherein the agent is trained to take customer orders and the like. Generally, agents who are employed to operate in such a call center work on site and

must log-in and be counted present so that calls can be routed to that particular agent.

In typical call center operations agents are primarily engaged in handling incoming calls from persons seeking services provided by the call center. This is not, however, the only task agents handle. In many instances there is a need for agents to make outgoing calls. An agent, for example, in interaction with a calling party, may need to research some item of information, then place a call back to the original caller. In other instances the primary function of the call center may be agent-initiated calls (sales, marketing for example). In any case, there are often reasons for agents taking part in calls originated at the call center, in addition to their other duties.

In the operation of call centers wherein calls are placed from the call center, it is known in the art to make such calls by an automatic outbound dialing system, wherein calls placed by the dialing system are answered by clients and then transferred quickly to available agents.

In most call centers, as previously described, an automatic dialer within the call center handles outbound dialing functions for the agents. In those call-centers wherein outbound calls are more prevalent, sufficient outbound channels (phone lines) must be provided to the call center so that the outbound dialer has enough channels available to keep every agent busy handling connected calls.

Because outbound dialing is automatic and a significant number of outbound calls will result in failure to connect to a real person, the hit ratio is always less than 1. If one automatically dialed outbound call is answered by a real person for every two calls made, for example, the hit ratio is 0.5.

The outbound dialer must have access to a sufficient number of channels so that connected calls may be transmitted to agents in a manner so as to keep them fairly engaged in taking calls. Therefore, at least two lines dedicated to placing outbound calls by the automatic dialer would be needed if the hit ratio is 0.5.

The outbound channels used by the automatic dialer at a customer's premise have to be assigned, leased lines. The cost, then, for the sponsor of the call center, in terms of payment for total lines, can be very significant.

In order to avoid the extra expense related to extra lines required for outbound dialing, many companies prefer to limit outbound dialing capability as much as possible. However, many businesses cannot do this as outbound calls may be key to their success. Very little has been done in the art at the time of the present application, however, to efficiently manage agent activity in handling outbound calls.

What is clearly needed is a method and apparatus wherein outbound calls can be made in automated fashion from an automatic dialing system at network level, transparent to the agent, and calls connected can be distributed efficiently among available agents. An outbound dialer such as this would require only one dedicated channel per agent at a call center, thus significantly reducing cost related to the leasing of extra lines.

#### SUMMARY OF THE INVENTION

In a preferred embodiment of the present invention an outbound dialer system is provided, comprising an automatic call dialer in a network having a network provider, the call center having capability of placing calls to pre-stored destination numbers; circuitry for recognizing a call answered by a person; and a calling list of destination numbers. The dialer places calls to the pre-stored destination

numbers, and upon a call being answered by a person, connects the completed call to a routing point in a remote call center. The network may be a publicly-switched telephone network (PSTN), or other wide area network (WAN).

In some cases the outbound dialer is sponsored by a single organization, and all connected calls are connected to the same routing point at the call center. In other cases the system further comprises a computer-telephony integration (CTI) processor, wherein the outbound dialer is sponsored by a single organization having a plurality of call centers, and completed calls are connected to routing points at individual ones of the plurality of call centers based on pre-stored routing criteria. A variety of routing criteria may be used, such as load-balancing and the like.

In some cases the system may be operated by the network provider. In this case the system further comprises a plurality of calling lists provided by a plurality of client organizations having call centers, and the system places outbound calls based on different calling lists, connecting completed calls to call centers operated by the client organizations providing the calling lists.

In another aspect of the invention a call center system is provided, comprising a call center having a call-switching apparatus connected to a telephone network by at least one multi-channel telephony trunk line, and a plurality of agent stations having telephones connected by station-side ports to the call-switching apparatus; and an outbound dialer in the network having a network provider, the outbound dialer having capability of placing calls to pre-stored destination numbers, circuitry for recognizing a call answered by a person, and a calling list of destination numbers. The dialer places calls to the pre-stored destination numbers, and upon a call being answered by a person, connects the completed call to a routing point in the call center. The network in this case a swell may be a publicly-switched telephone network (PSTN). The dialer may be sponsored by a single organization having one or a plurality of call centers, or may be hosted by the network service provider serving a variety of clients as a subscription service.

In another aspect a method for practicing the invention is provided, comprising steps of (a) placing outbound calls by an automatic dialer in a network servicing the call center, according to destination numbers provided by the call center; (b) determining when a call is answered by a person; and (c) connecting answered calls to a routing point at the call center.

The system according to various embodiments of the invention minimizes the number of leased lines a call center has to have to keep a set of agents busy, and by so doing, minimizes the cost of operating a call center operating at least partially on placing outgoing calls to destination numbers. Objects of the invention are more fully explained below, and enabling embodiments of the invention are taught.

#### BRIEF DESCRIPTION OF THE DRAWING FIGURES

FIG. 1 is an overview of a typical call center utilizing outbound dialing according to current art.

FIG. 2 is a simple overview of a call center utilizing outbound dialing according to an embodiment of the present invention.

#### DESCRIPTION OF THE PREFERRED EMBODIMENTS

FIG. 1 is an overview of a typical call center 11 in a telephony system 9 utilizing outbound dialing according to

5

current art. Call center **11** comprises a telephony switching apparatus **19** connected in this embodiment to a computer-telephony integration (CTI) processor **25** via CTI link **23**. CTI processor **25** provides computerized functions for switch **19**, and is capable of both monitoring switch activity and controlling switch activity. Switch **19** may be an automatic call distributor (ACD), a private branch exchange (PBX), or another type of telephony switch such as known in the art, having a CTI interface.

Switch **19** is connected via a telephone wiring system **32** to agent workstations **27a-27d** from station-side ports. Each workstation **27a-d** comprises a personal computer/video display unit (PC/VDU) and a switch-connected telephone such as PC/VDU's **29a-29d** and telephones **31a-31d** respectively. Workstations **27a-d** share a connection through their PC/VDU's to a local area network (LAN) **26**. LAN **26** also has connected thereto a data server **28** for storing and providing data to CTI processor **25** and to PC/VDUs at agent's stations.

Incoming calls to agents at call center **11** arrive from, in this example, a publicly switched telephone network (PSTN) **13** via incoming trunk **17**. In other embodiments the network may be a corporate wide-area network (WAN) or other WAN.

In the example of FIG. **1** an outbound dialer **21** is linked to CTI processor **25** which is both switch- and LAN-connected. Outbound dialer **21** is automatic and operated by software according to a predetermined protocol. Outbound dialer **21** may reside separately as illustrated, or may reside in switch **19** or processor **25**. It is shown as a separate unit here solely for the purpose of clarification.

Outbound dialer **21** places calls to clients **15** over an outbound trunk **16** which comprises telephony channels from switch **19** into PSTN **13**. In this example the channels of trunk **16** are dedicated to outbound dialing. Trunk **16** in this example comprises at least double the number of channels as the number of agents who are actively logged onto the system for reasons as previously described with reference to the background section. That is, that many calls are not answered, others are picked up by automatic systems and the like, and only a portion are actually answered by person.

One with skill in the art will appreciate that many agents may be present and active in a very large call center requiring significant trunking architecture to effect efficient outbound dialing. The example presented here shows only **4** agents, but is deemed sufficient by the inventor for the purpose of illustrating basic call-center functionality. There are, as well, functional elements that are well known to be present in typical call-center architecture that are not illustrated here. These elements may include customer information system servers (CIS), interactive voice response units (IVR), Routers, Stat-Servers, and other such components. Such conventional elements may be assumed to be present in embodiments of the present invention.

FIG. **2** is an overview of a call center utilizing outbound dialing according to an embodiment of the present invention, wherein the outbound dialing function resides at the network level. Telephony communications system **33** comprises many of the same elements described above with reference to FIG. **1**. Therefore, elements of FIG. **2** that remain the same in function are shown with the same element numbers and will not be reintroduced. Outbound dialer **21** in this embodiment operates in the PSTN, and is supported by a CTI processor **26**, which may be the same as, or similar to, CTI processor **25** at the call center. In other embodiments processor **25** may have a digital link **24**

6

(shown as a dotted line, indicating optional) to dialer **21** in the network, and processor **26** may not be needed.

The innovative technique of providing outbound dialing at the network level allows fewer dedicated lines to be employed between switch **19** and PSTN **13**. For example, trunk **16** of FIG. **1** (prior art) must maintain at least 8 outbound channels to accommodate agents at workstations **27a-d**, assuming a ration of 1 out of two outbound calls being answered by a person. This high number of lines (channels) needed for the purpose of placing the outbound calls all have to be paid for. However, implementing dialer **21** at the level of PSTN **13** allows an inbound trunk **35** (FIG. **2**), consisting of substantially the same number of channels as number of active agents, to be used, keeping all agents busy, because the outbound dialer now needs but one line per active agent to route connected calls.

In a preferred embodiment the outbound dialer at network level places calls to destination numbers provided by one or more call-center hosts. When a call is answered by a person, the call is connected to a routing point at the pertinent call center. The call is then routed to an agent according to any routing rules in force at the call center. These routing rules may be relatively sophisticated, incorporating agent skill level and the like, or may be on the basis of an Automatic Call Distributor (ACD) as known in the art. In some minimal embodiments calls may be dialed through directly to agents.

In alternative embodiments the routing functions may be at network level as well, including ACD or more sophisticated routing, in which case connected calls accomplished by the outbound dialer at network level may be directed to agents stations rather than to a routing point at a call center. In other embodiments ACD at the network level may accomplish routing to secondary routing points at call centers based on availability and/or loading, and further routing is then accomplished at the call center routing point.

In one embodiment of the present invention, the outbound dialing capability is hosted by the network provider, and offered to companies (clients of the network provider) hosting call centers as a subscription service. A company hosting several distributed call centers can now share costs with other similar companies via the fact that all outbound calls are shared over network lines. In this way, the cost for the service will be substantially less than each company maintaining their own outbound dialing systems within their own call centers. If there is no cost for busy or failed connections as is the case with most shared public lines, costs may be reduced even further.

In another embodiment of the present invention, routers are distributed within PSTN **13** with each router associated with a separate call center that may be hosted by one or more companies. The same outbound dialing system could accommodate all of the call centers.

In yet another embodiment of the present invention, scaled-down versions of the outbound dialing system could be distributed so that each call center connected to a distributed router would have it's own outbound dialer.

A DNT application has routing nodes in a digital data network instead of routers as known in connection-oriented, switched systems, analog to digital conversion is employed, and WAN access is provided. A combination DNT/CTI outbound dialing system is also provided as one possible architecture adapted for converting analog to digital and vice versa. In this way DNT call centers and CTI call centers may subscribe to the same service. The service in some embodiments is offered by a third party telecommunications company, in others by the local telephone company, or perhaps,



may be set-up as a joint venture involving several companies hosting call centers as a way to share and reduce costs.

It will be apparent to one with skill in the art that by placing outbound dialing capability within the telephone network, significant savings can be realized by individual companies maintaining call centers. It will also be apparent to one with skill in the art that by utilizing distributed architecture within the network, that costs may even be further reduced due to sharing of the network lines.

The spirit and scope of the present invention is limited only by the claims that follow.

What is claimed is:

1. An outbound dialer system comprising:
  - a network level by a network provider, the automatic call dialer having the capability of placing calls selected from one or more stored lists of destination numbers provided by one or more clients of the network provider; and
  - circuitry for recognizing that at least one of said placed calls is answered by a person;
    - wherein the dialer places said calls to the selected destination numbers, and upon a first one of said placed calls being answered by a first person, connects the answered first call to a first routing point in a remote call center hosted by a first client of the one or more clients of the network provider, and upon a second one of the placed calls being answered by a second person, connects the answered second call to a second routing point in a second remote call center hosted by a second remote call center different from the first remote call center, wherein the second remote call center is hosted by a second client of the one or more clients of the network provider.
2. The outbound dialer system of claim 1 wherein the network is a publicly-switched telephone network (PSTN).
3. The outbound dialer system of claim 1 wherein the outbound dialer system is hosted by a single client of the network provider, and all calls completed to persons are then connected to a routing point at a call center also hosted by the single client.
4. [The outbound dialer system of claim 3 further comprising] *An outbound dialer system comprising:*
  - a network level by a network provider, the automatic call dialer having the capability of placing calls selected from one or more stored lists of destination numbers provided by one or more clients of the network provider;
  - circuitry for recognizing that at least one of said placed calls is answered by a person, wherein the dialer places said calls to the selected destination numbers, and upon one of said placed calls being answered by a person, connects the answered call to a routing point in a remote call center hosted by a client of the network provider; and
  - a computer-telephony integration (CTI) processor connected to the automatic call dialer, wherein the outbound dialer system is sponsored by a single client hosting a plurality of call centers, and wherein calls completed to persons are then connected to routing points at individual ones of the plurality of call centers based on pre-stored routing criteria.
5. The outbound dialer system of claim 4 wherein said completed calls are routed to individual call centers based on a load-balancing algorithm.

6. [The outbound dialer system of claim 1] *An outbound dialer system comprising:*

*an automatic call dialer implemented and operated at network level by a network provider, the automatic call dialer having the capability of placing calls selected from one or more stored lists of destination numbers provided by one or more clients of the network provider; and*

*circuitry for recognizing that at least one of said placed calls is answered by a person,*

*wherein the dialer places said calls to the selected destination numbers, and upon one of said placed calls being answered by a person, connects the answered call to a routing point in a remote call center hosted by a client of the network provider,*

wherein the system further comprises a plurality of calling lists provided by a plurality of clients hosting call centers, and wherein the system places outbound calls from different calling lists, connecting calls completed to persons to call centers operated by the clients providing the calling lists.

7. A call center system, comprising:

[at least one] *a plurality of call [center] centers each having a call-switching apparatus connected to a telephone network hosted by a network provider by at least one multi-channel telephony trunk line, and a plurality of agent stations having telephones connected by station-side ports to the call-switching apparatus, the [at least one] plurality of call [center] centers hosted by a client of the network provider; and*

an outbound dialer in the network implemented and operated by the network provider, the outbound dialer having the capability of placing calls to destination numbers selected from stored lists of destination numbers provided by the client, and circuitry for recognizing that at least one of said placed calls is answered by a person;

wherein the outbound dialer places said calls to the selected destination numbers, and upon a first one of said placed calls being answered by a first person, connects the answered first call to a first routing point in [the at least one] *a first call center of the plurality of call [center] centers, and upon a second one of said placed calls being answered by a second person, connects the answered second call to a second routing point in a second call center of the plurality of call centers, wherein the second call center is different from the first call center.*

8. The call center system of claim 7 wherein the network is a publicly-switched telephone network (PSTN).

9. The call center system of claim 7 wherein the outbound dialer system is hosted by a simple client of the network provider, and all of said calls answered by a person are connected to a routing point at the at least one call center.

10. [The call center system of claim 7 further comprising] *A call center system, comprising:*

*at least one call center having a call-switching apparatus connected to a telephone network hosted by a network provider by at least one multi-channel telephony trunk line, and a plurality of agent stations having telephones connected by station-side ports to the call-switching apparatus, the at least one call center hosted by a client of the network provider;*

*an outbound dialer in the network implemented and operated by the network provider, the outbound dialer having the capability of placing calls to destination numbers selected from stored lists of destination num-*

9

*bers provided by the client, and circuitry for recognizing that at least one of said placed calls is answered by a person, wherein the outbound dialer places said calls to the selected destination numbers, and upon one of said placed calls being answered by a person, connects the answered call to a routing point in the at least one call center; and*

a computer-telephony integration (CTI) processor connected to the outbound dialer and a plurality of call centers hosted by the single client, wherein said calls answered by a person are then connected to routing points at individual ones of the plurality of call centers based on pre-stored routing criteria.

11. The call center system of claim 10 wherein said answered calls are routed to individual call centers based on a load-balancing algorithm.

12. [The call center system of claim 7] *A call center system, comprising:*

*at least one call center having a call-switching apparatus connected to a telephone network hosted by a network provider by at least one multi-channel telephony trunk line, and a plurality of agent stations having telephones connected by station-side ports to the call-switching apparatus, the at least one call center hosted by a client of the network provider; and*

*an outbound dialer in the network implemented and operated by the network provider, the outbound dialer having the capability of placing calls to destination numbers selected from stored lists of destination numbers provided by the client, and circuitry for recognizing that at least one of said placed calls is answered by a person,*

*wherein the outbound dialer places said calls to the selected destination numbers, and upon one of said*

10

*placed calls being answered by a person, connects the answered call to a routing point in the at least one call center;*

wherein the system further comprises a plurality of calling lists provided by a plurality of clients hosting call centers, and wherein the outbound dialer places outbound calls from different calling lists, connecting said calls answered by person to call centers operated by the clients providing the calling lists.

13. A method for minimizing the number of outgoing channels required for a *plurality of call [center] centers* having a plurality of agents and operating by outbound dialing, comprising steps of:

(a) providing, by the call center, one or more stored lists of destination numbers to be called to an automated outbound dialer implemented and operated by a network provider at network level;

(b) placing outbound calls by the automated outbound dialer in in the network servicing the call center, according to the list of destination numbers provided by the call center;

(c) determining when [individual ones] *a first one* of said outbound calls are answered by a *first* person; and

(d) connecting said [calls] *first call* answered by [a] *the first* person to a *first* routing point at [the] *a first* call center of the plurality of call centers;

(e) determining when a *second one* of said outbound calls are answered by a *second* person; and

(f) connecting said *second call* answered by the *second* person to a *second* routing point at a *second* call center of the plurality of call centers, wherein the *second* call center is different from the *first* call center.

\* \* \* \* \*