

(19)
(12)

(KR)
(B1)

(51) 。 Int. Cl.7
G11B 7/08

(45)
(11)
(24)

2004 07 02
10-0438276
2004 06 22

(21) 10-2001-0007356
(22) 2001 02 14

(65)
(43)

10-2002-0066899
2002 08 21

(73) 20

(72) 1 481-25 1

101 203

(74)
:

(54) 가

가 , , 가 , 가
가 , , 가 , 가
가 가 3 , .

2

1
2 가 .
3 , 가
4 , 가
5 , .
< >

11,111,211... 12,112,212...
 13,113,213... 14,114,214,121,221...
 15,115,215... 16,116,216...
 17,117,217... 118...
 119,219... 120,220...

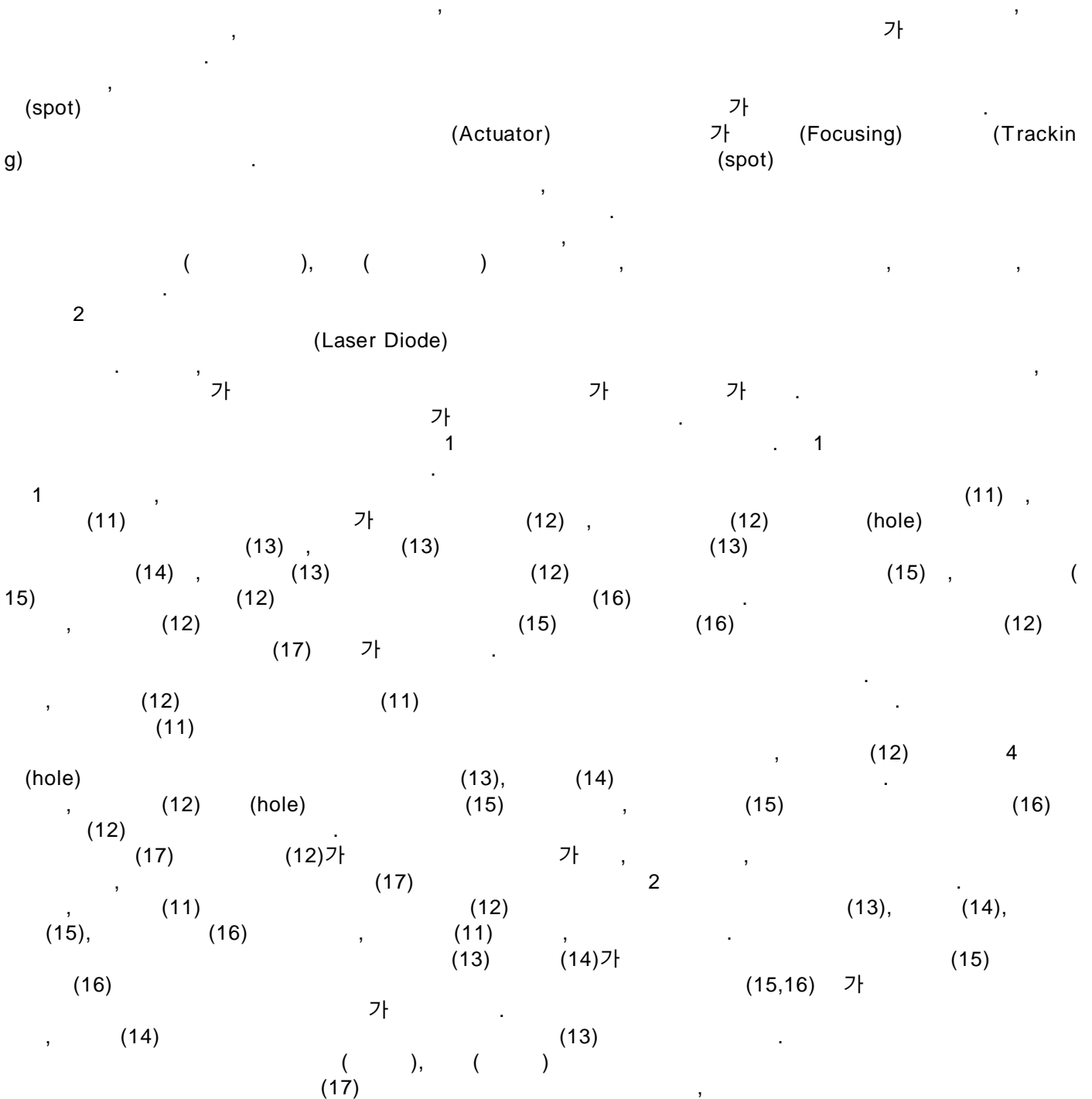

(tracking, focusing)

가

가

3

, 3

가

2

가

2

1

가

가

가

3

가

2

가

가

가

2

가

1

가

4

가

2

가

3

2

1

12)
) ,

2

3

5

3

2

(111)

가

(113),

가

(114),

(112)

,

(1

(115,116

0)

(122)

4

5

(119)

(123)

(119)

(120)

(112)

(121)

(118)

,

(12

2

4

(220)

(212)

가

(219)

,

가

1
2
le)

3

,

(112)

(113)가

(116)

(111)

가

(ho

(114)

(115)

(116)

(113)

(115)

가

(115)

(115)

(115)

(112)

(113),

(114)

(113),

(114)

(115)

(116)

가

(116)

(112)

(118)

(118)

(119)

(122)

(123)

(121)

(120)

가

(119)

(120)

(118)

(119)

(120)

(119)

(122)

(119)

(122)

(119)

(119)

(120)

가

3

(a)

(120)

(112)가

(112)

(N:S)

(119)

,

(120)

(120)

(120)

(120)

(120)

(120)

가

, 3 (b) , (119) (N:S) (120) 가
 , (120) , (N:S,S:N)가 , (120) 가
 , (112) ,
 a)(b) (119) (120) 가 3 (가
 2 ; 2 4 5 , 3 (가
 1 , (212) , (219) (220) (N:S)
 219) , (N:S) , (219) (220) (가
 , 가 5 , 5 (a) , (219) N:S
 , (220) 가 , (212) ,
 가 5 (b) , (219) N:S, S:N (220)
 (219) (219) (N:S, S:N) (212)
 2 , (212)
 5 (a)(b) , (219) (220) 가
 (212) , (219) (220)
 (211) 가 (219)가 (212)

가 , ,
 가 , 가
 가

(57)

1.

가

가

2.

1

가

3.

1

가

1

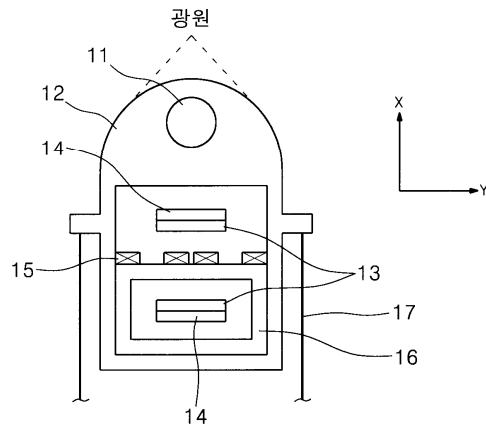

2

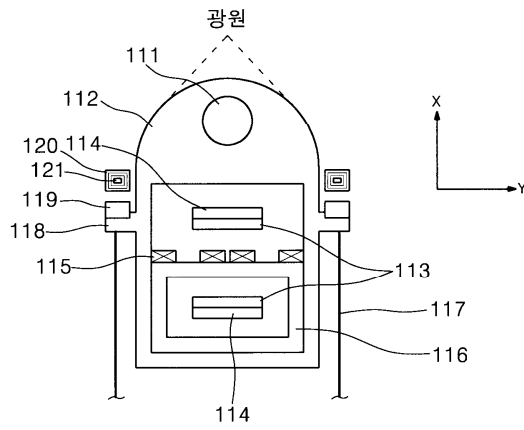

3

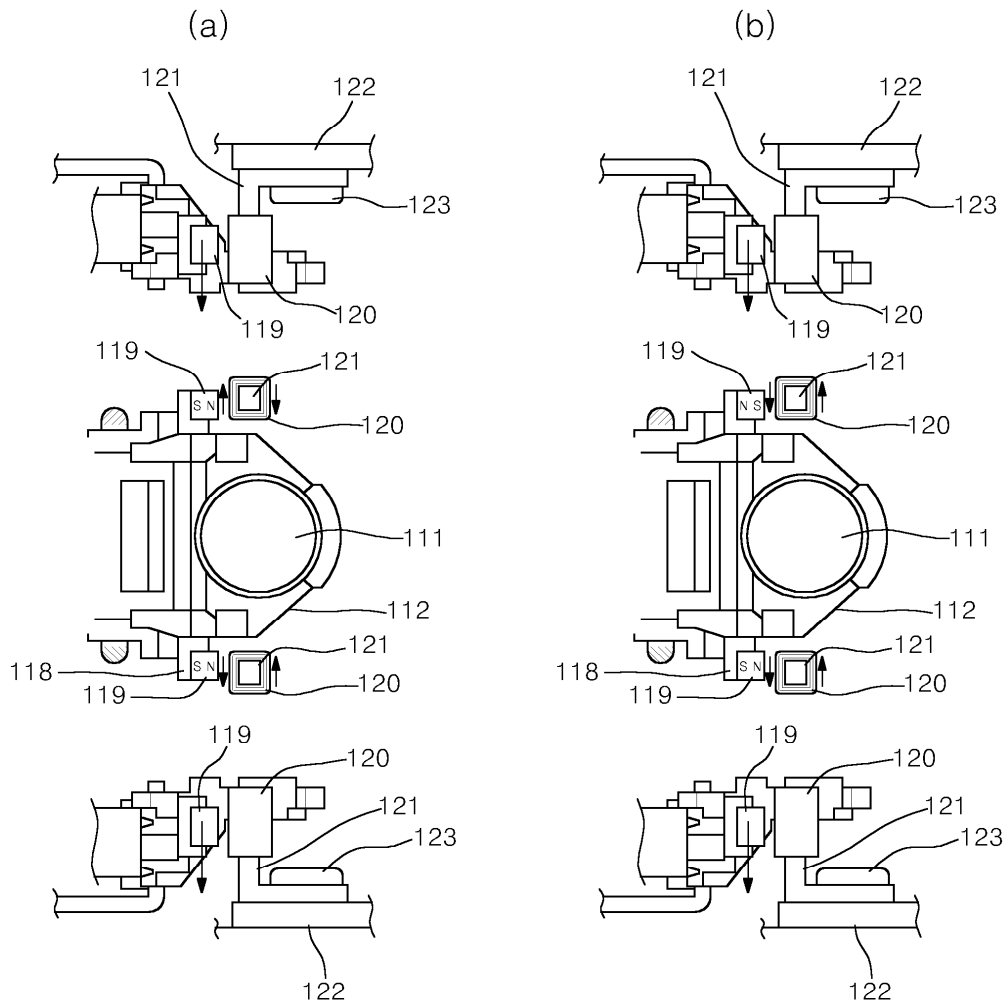

4

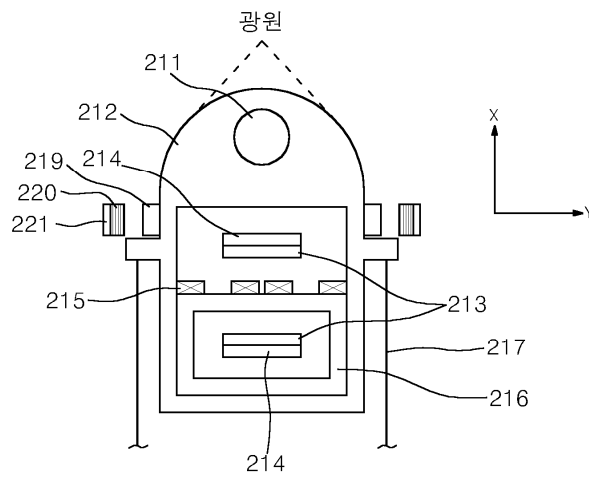

5

(a)

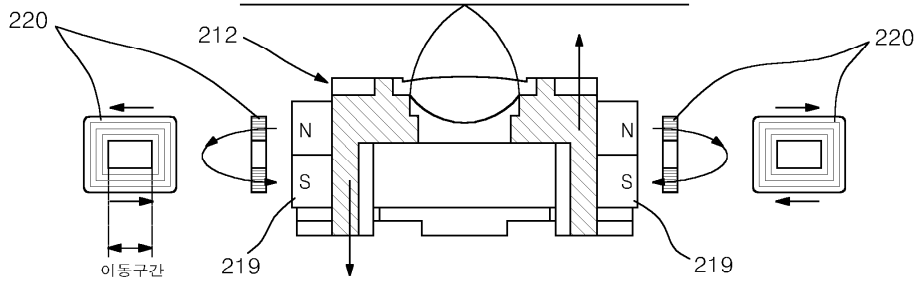

(b)

