



(12) **United States Design Patent**
Levine

(10) **Patent No.:** **US D905,658 S**
(45) **Date of Patent:** **** Dec. 22, 2020**

(54) **ADJUSTMENT PORTION OF A HEADPHONE DEVICE**

- (71) Applicant: **New Audio LLC**, New York, NY (US)
- (72) Inventor: **Jonathan E. Levine**, New York, NY (US)
- (73) Assignee: **New Audio, LLC**, New York, NY (US)
- (**) Term: **15 Years**
- (21) Appl. No.: **29/695,994**
- (22) Filed: **Jun. 24, 2019**

Related U.S. Application Data

- (63) Continuation of application No. 29/636,718, filed on Feb. 9, 2018, now Pat. No. Des. 857,654, which is a continuation of application No. 29/583,762, filed on Nov. 8, 2016, now Pat. No. Des. 812,588, which is a continuation of application No. 29/532,834, filed on Jul. 10, 2015, now Pat. No. Des. 772,841, which is a continuation of application No. 29/481,794, filed on Feb. 10, 2014, now Pat. No. Des. 736,174.
- (51) **LOC (12) Cl.** **14-01**
- (52) **U.S. Cl.**
USPC **D14/205**
- (58) **Field of Classification Search**
USPC D14/205, 206, 188, 192, 203.5; D29/112; 2/209, 8.1, 339, 322; 24/163 R, 170, 604, 606, 614, 619, 320, 24/194, 593.11, DIG. 47, 71.1; 379/430, 379/455; 381/380, 381, 183, 379, 378, 381/374, 371; 211/184; 224/275
CPC H04R 1/1066; H04R 1/1016; H04R 5/033; H04R 5/0335; H04R 25/00; H04R 1/105; H04R 1/1075; H04R 1/1008
See application file for complete search history.

(56) **References Cited**

U.S. PATENT DOCUMENTS

1,127,161 A *	2/1915	Baldwin	H04R 5/0335	381/379
1,483,315 A	2/1924	Saal			
1,648,832 A	11/1927	Urban			
1,651,623 A	12/1927	Obergfell			
1,714,377 A *	5/1929	Kiernan	H04R 1/10	381/378
2,010,612 A *	8/1935	Stafford	A44B 11/24	2/322
2,140,132 A *	12/1938	Hollett	B60D 1/025	280/492
2,235,372 A *	3/1941	Kalbitz	H04R 1/1066	381/371
2,486,267 A *	10/1949	Dulinsky	H04R 5/0335	381/377

(Continued)

FOREIGN PATENT DOCUMENTS

- JP 2015026948 A 2/2015
- Primary Examiner* — Paula Allen Greene
- (74) *Attorney, Agent, or Firm* — Holzer Patel Drennan

(57) **CLAIM**

The ornamental design for an adjustment portion of a headphone device, as shown and described.

DESCRIPTION

FIG. 1 is a perspective view of an adjustment portion of a headphone device showing my new design.
 FIG. 2 is a front elevational view thereof.
 FIG. 3 is a back elevational view thereof.
 FIG. 4 is a first side elevational view thereof.
 FIG. 5 is a second side elevational view thereof.
 FIG. 6 is a top plan view thereof; and,
 FIG. 7 is a bottom plan view thereof.
 The broken lines depict environment that forms no part of the claimed design.

1 Claim, 5 Drawing Sheets

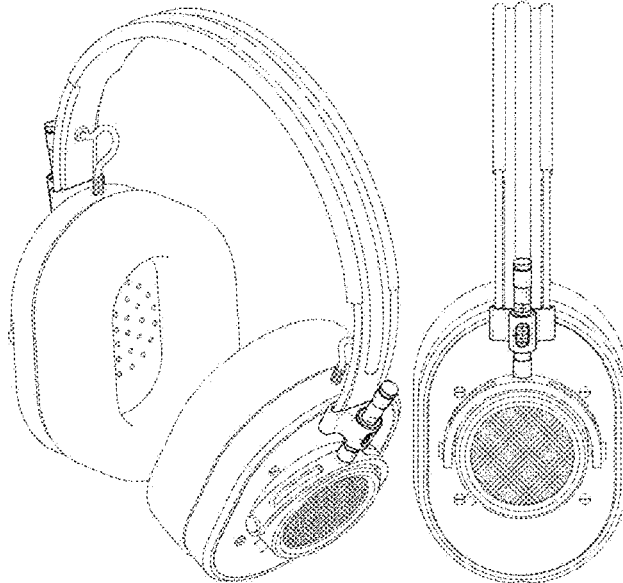

(56)

References Cited

U.S. PATENT DOCUMENTS

2,497,007	A *	2/1950	Melidoni	F16G 11/12	24/71.1	D639,776	S	6/2011	Arimoto	
2,503,432	A *	4/1950	Bowers	A42B 3/145	600/242	D652,021	S	1/2012	Miyawaki	
2,511,234	A *	6/1950	Anderson	A42B 3/145	2/8.1	D652,022	S	1/2012	Miyawaki	
2,652,457	A *	9/1953	Knowles	H04M 1/05	381/151	8,098,872	B2	1/2012	Chang	
2,747,191	A *	5/1956	Hoffmaster	A61F 9/06	2/8.1	D657,344	S	4/2012	Brunner	
2,782,423	A *	2/1957	Simon	A61F 11/14	2/209	D662,080	S	6/2012	Carr	
2,858,544	A	11/1958	Roth				8,213,644	B2	7/2012	Choi	
2,946,860	A *	7/1960	Jansen	H04R 1/1008	181/129	D666,579	S	9/2012	Hou	
3,073,410	A	1/1963	Gongoll				8,325,962	B2	12/2012	Ishida et al.	
3,183,565	A *	5/1965	Schwarz	F16G 11/12	24/71.1	D677,243	S	3/2013	Kitayama	
3,440,663	A	4/1969	Beguín				D680,999	S	4/2013	Chan	
3,454,964	A	7/1969	Brinkhoff				8,737,668	B1	5/2014	Blair et al.	
3,488,457	A	1/1970	Lahti				D706,241	S	6/2014	Szymanski	
3,505,684	A	4/1970	Hutchinson				8,755,555	B2	6/2014	Dougherty	
3,562,816	A	2/1971	Hutchinson				D712,872	S	9/2014	Yuen	
3,579,640	A	5/1971	Beguín				D721,052	S	1/2015	Carr	
3,593,341	A	7/1971	Aileo				D727,280	S *	4/2015	Levine	D14/205
3,815,155	A	6/1974	Davison				D727,281	S *	4/2015	Levine	D14/205
3,908,200	A *	9/1975	Lundin	A61F 11/14	2/209	D728,512	S	5/2015	Nakagawa	
3,922,725	A	12/1975	Csiki et al.				D729,194	S	5/2015	Boeckel et al.	
3,984,885	A	10/1976	Yoshimura				D736,174	S *	8/2015	Levine	D14/205
D244,301	S	5/1977	Besasio				D736,175	S	8/2015	Levine	
4,274,181	A *	6/1981	Schaller	G10G 5/005	224/257	D737,799	S	9/2015	Carr	
4,309,575	A *	1/1982	Zweig	H04R 1/1066	381/151	D741,842	S	10/2015	Levine	
4,437,538	A	3/1984	Ohlsson				D746,790	S	1/2016	Strasberg	
4,439,645	A	3/1984	Scalzo				D762,190	S	7/2016	Levine	
4,472,607	A *	9/1984	Houng	H04M 1/05	181/18	D762,191	S	7/2016	Levine	
4,727,585	A *	2/1988	Flygstad	H04R 5/0335	2/209	D765,055	S	8/2016	Hsieh	
4,747,145	A *	5/1988	Wiegel	H04M 1/05	381/378	D768,110	S	10/2016	Suzuki	
4,829,571	A *	5/1989	Kakiuchi	H04R 1/1033	381/309	D772,841	S	11/2016	Levine	
5,035,005	A	7/1991	Hung				D772,841	S	11/2016	Levine	
5,293,647	A *	3/1994	Mirmilshsteyn	H04R 1/10	2/209	D780,155	S	2/2017	Levine et al.	
5,438,626	A	8/1995	Neuman et al.				D781,265	S	3/2017	Levine et al.	
5,499,985	A *	3/1996	Hein	A61B 17/162	24/573.11	D781,814	S	3/2017	Levine	
D410,466	S	6/1999	Mouri et al.				D782,995	S	4/2017	Matthews	
D432,522	S	10/2000	Kieltyka				D789,327	S	6/2017	Miyake	
6,201,877	B1 *	3/2001	Chang	H04R 1/08	381/364	D792,376	S	7/2017	Morimoto	
6,263,085	B1	7/2001	Weller				D795,218	S	8/2017	Ohmachi	
6,392,196	B1	5/2002	Lin				9,729,954	B2	8/2017	Levine et al.	
6,427,018	B1 *	7/2002	Keliiliki	H04R 1/1066	381/381	D805,056	S *	12/2017	Levine	D14/205
7,251,335	B1 *	7/2007	Chen	H04R 1/1083	381/384	D810,055	S	2/2018	Levine	
D613,266	S *	4/2010	Barry	D14/205		D812,588	S	3/2018	Levine	
D620,474	S	7/2010	Komiyama				D820,810	S	6/2018	Levine et al.	
D633,895	S *	3/2011	Morimoto	D14/205		D832,811	S	11/2018	Levine et al.	
D635,958	S *	4/2011	Ando	D14/205		D832,813	S	11/2018	Levine et al.	
							D852,166	S *	6/2019	Levine	D14/205
							D857,652	S *	8/2019	Wang	D14/205
							D857,654	S *	8/2019	Levine	D14/205
							D878,329	S *	3/2020	Levine	D14/205
							D882,544	S *	4/2020	Paterson	D14/205
							10,743,106	B2 *	8/2020	Daley	H04R 1/105
							2003/0210801	A1	11/2003	Naksen et al.	
							2004/0216946	A1	11/2004	Lenhard-Backhaus	
							2005/0105755	A1	5/2005	Yueh	
							2005/0266875	A1	12/2005	Yegin et al.	
							2007/0223766	A1	9/2007	Davis et al.	
							2008/0056525	A1	3/2008	Fujiwara et al.	
							2010/0177907	A1	7/2010	Morisawa	
							2012/0070028	A1	3/2012	Margulies	
							2012/0093334	A1	4/2012	Schreuder et al.	
							2016/0079660	A1	3/2016	Bevelacqua	
							2016/0205461	A1	7/2016	Fernandez-Medina et al.	
							2017/0041696	A1	2/2017	Levine et al.	
							2017/0041697	A1	2/2017	Levine	
							2017/0134845	A1	5/2017	Milam et al.	
							2017/0265420	A1	9/2017	Carlson	
							2017/0339479	A1	11/2017	Levine	
							2018/0020277	A1	1/2018	Briggs	
							2018/0020278	A1	1/2018	Levine et al.	

* cited by examiner

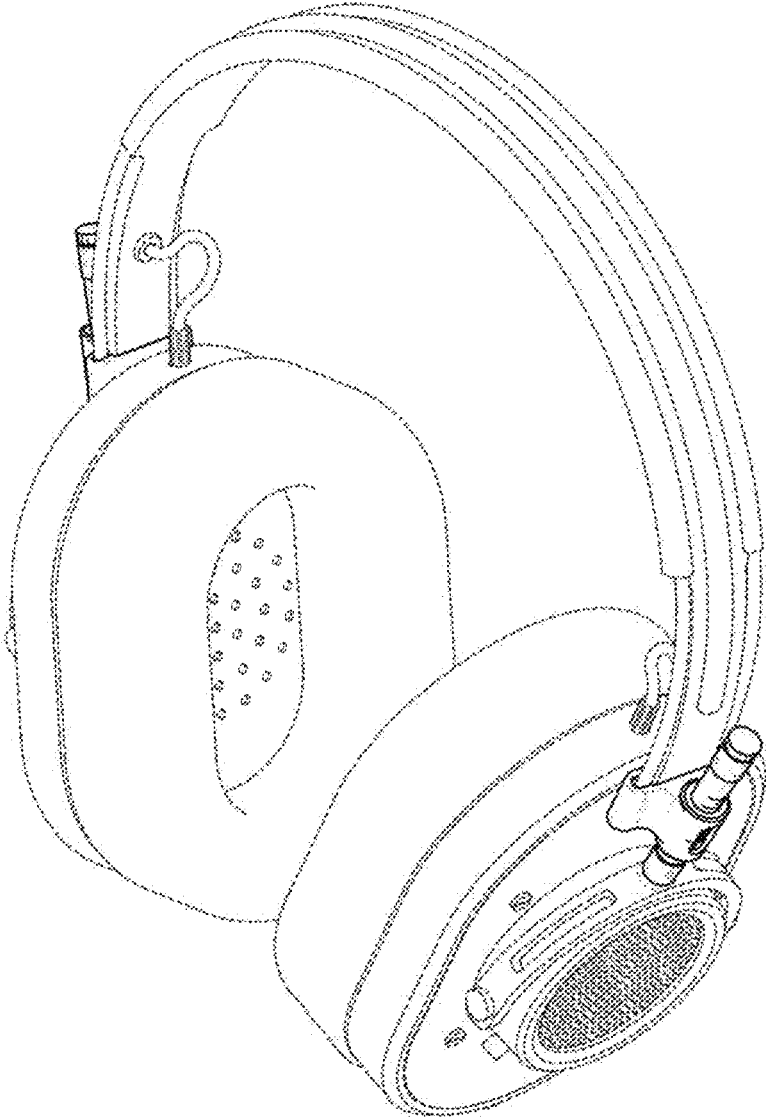

Fig. 1



Fig. 2

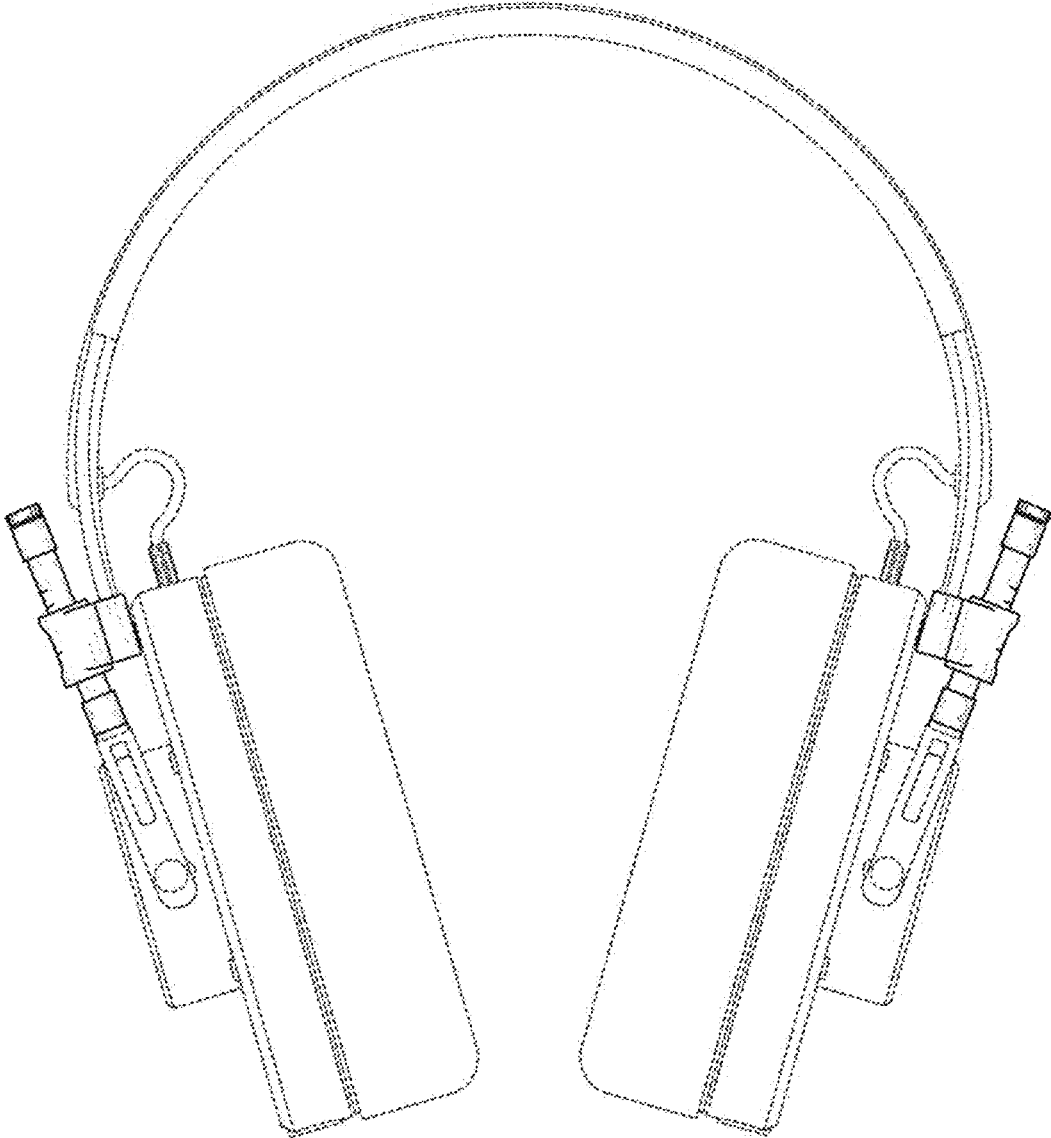

Fig. 3

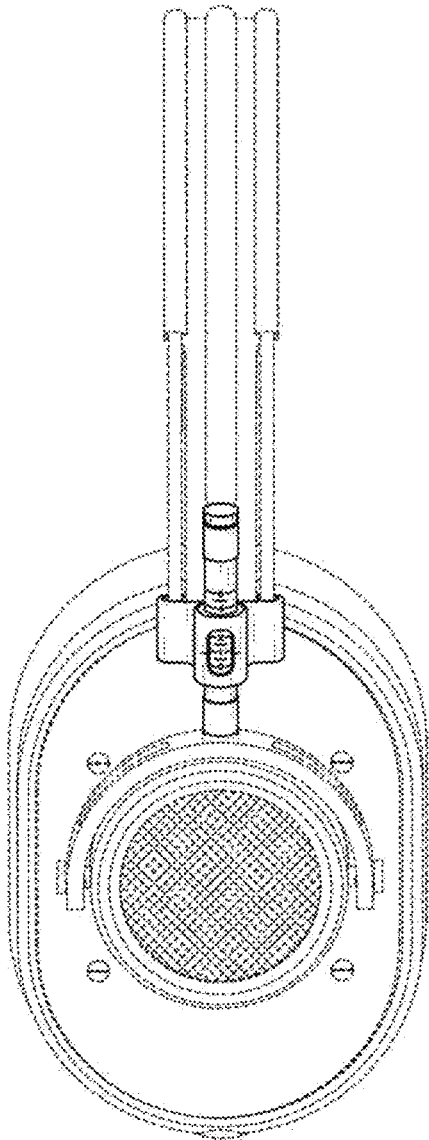

Fig. 4

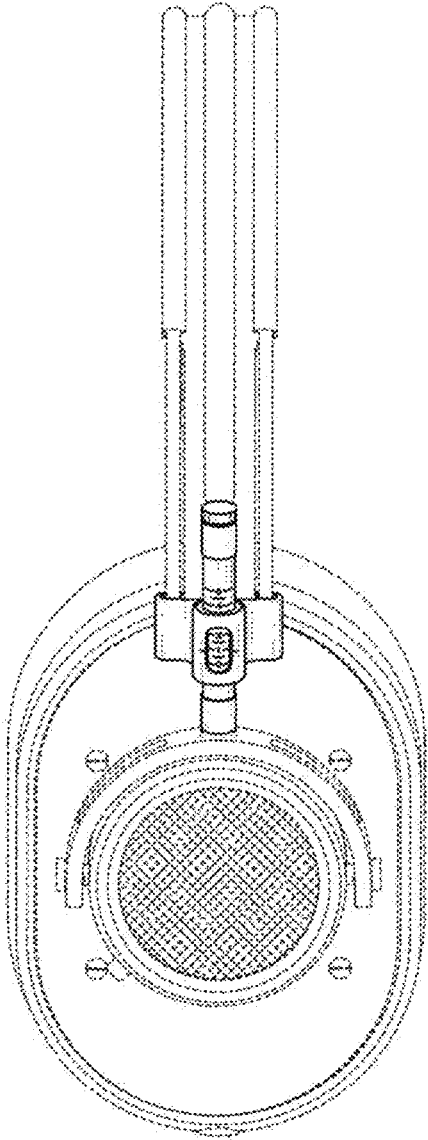

Fig. 5

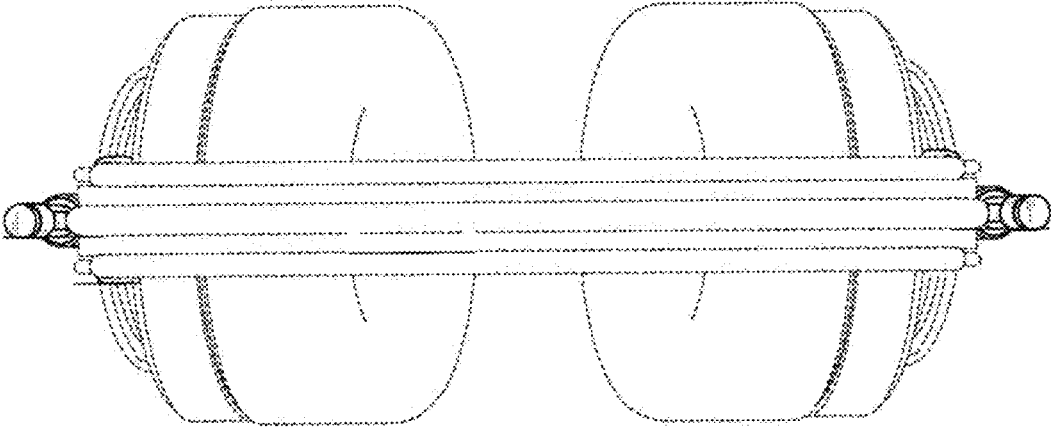

Fig. 6

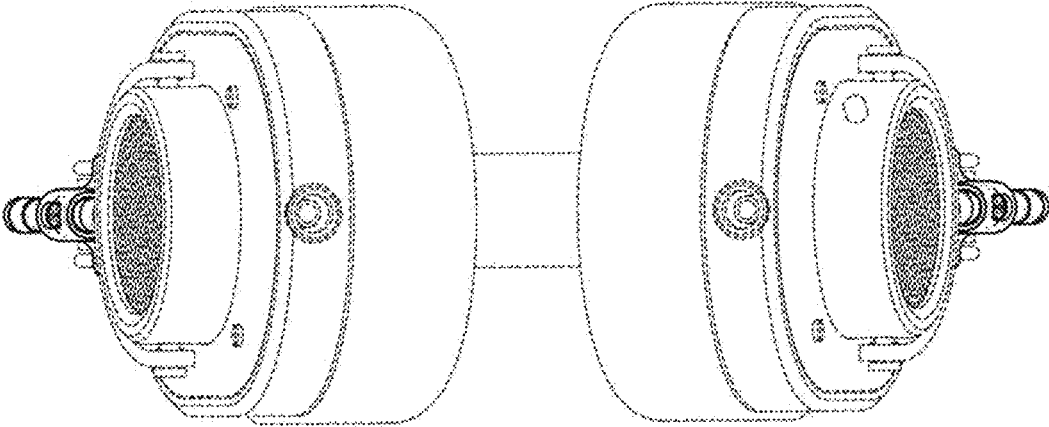

Fig. 7