

(12) **UK Patent Application** (19) **GB** (11) **2 383 824** (13) **A**

(43) Date of A Publication **09.07.2003**

(21) Application No **0200173.3**

(22) Date of Filing **04.01.2002**

(71) Applicant(s)
Hsin-Tsai Wu
1F, No 19, Alley 3, Lane 106, Sec 3,
Min-Chuan E Rd, Taipei City, Taiwan

(72) Inventor(s)
Hsin-Tsai Wu

(74) Agent and/or Address for Service
Marks & Clerk
57-60 Lincoln's Inn Fields, LONDON,
WC2A 3LS, United Kingdom

(51) INT CL⁷
F04B 19/00

(52) UK CL (Edition V)
F1W WAB WEX W104

(56) Documents Cited
WO 2001/087121 A **US 6332760 A**
US 20010044969 A **US 20010026763 A**

(58) Field of Search
UK CL (Edition T) **A4M M1B2 M1B6, B7A AAAJ AAAT**
A424, F1W WAB WEX W104, F2V VG10 VV3 VV8 VW22
INT CL⁷ **A47C 27/08, F04B 17/00 19/00, F04D 29/60**
Other: **ONLINE: WPI; EPODOC; JAPIO**

(54) Abstract Title
Inflation seat assembly for an inflatable article

(57) An inflation seat assembly 1 is adapted for connecting an inflatable article 2 to a motor-driven air pump 3. The air pump 3 has air inlet and outlet ports 31, 32, and is operable so as to draw and supply air via the air inlet and air outlet ports 31, 32, respectively. The inflation seat assembly 1 includes a casing 10, an inlet check valve 11, an air outlet 12, and a closure member 13. The casing 10 has a base wall 101, a peripheral wall 102, and a skirt flange 103. The base and peripheral walls 101, 102 cooperate to form a receiving space 104 for retaining the air pump 3 removably therein. The inlet check valve 11 can be coupled to the air outlet port 32 of the air pump 3, and permits air flow into the inflatable article 2. The air outlet 12 is in fluid communication with the inflatable article 2. The closure member 13 is used to close selectively the air outlet 12.

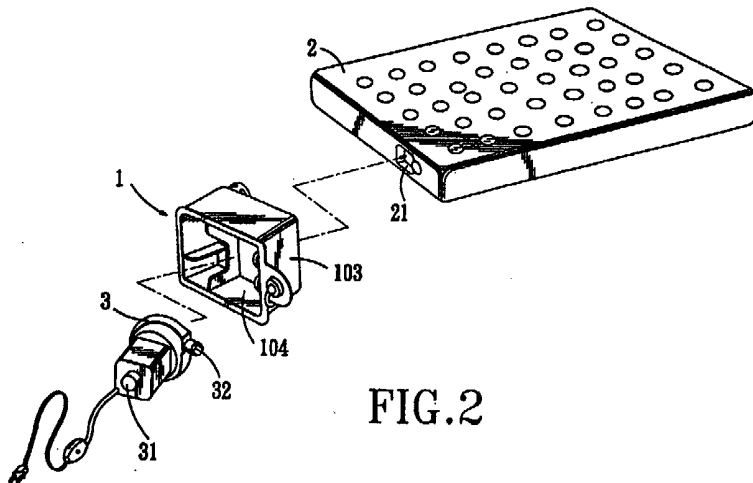

FIG. 2

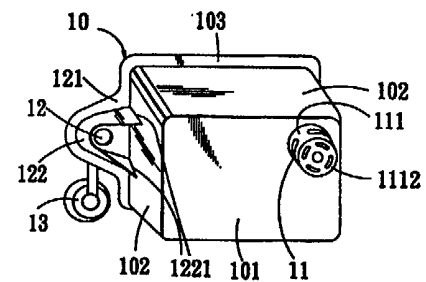
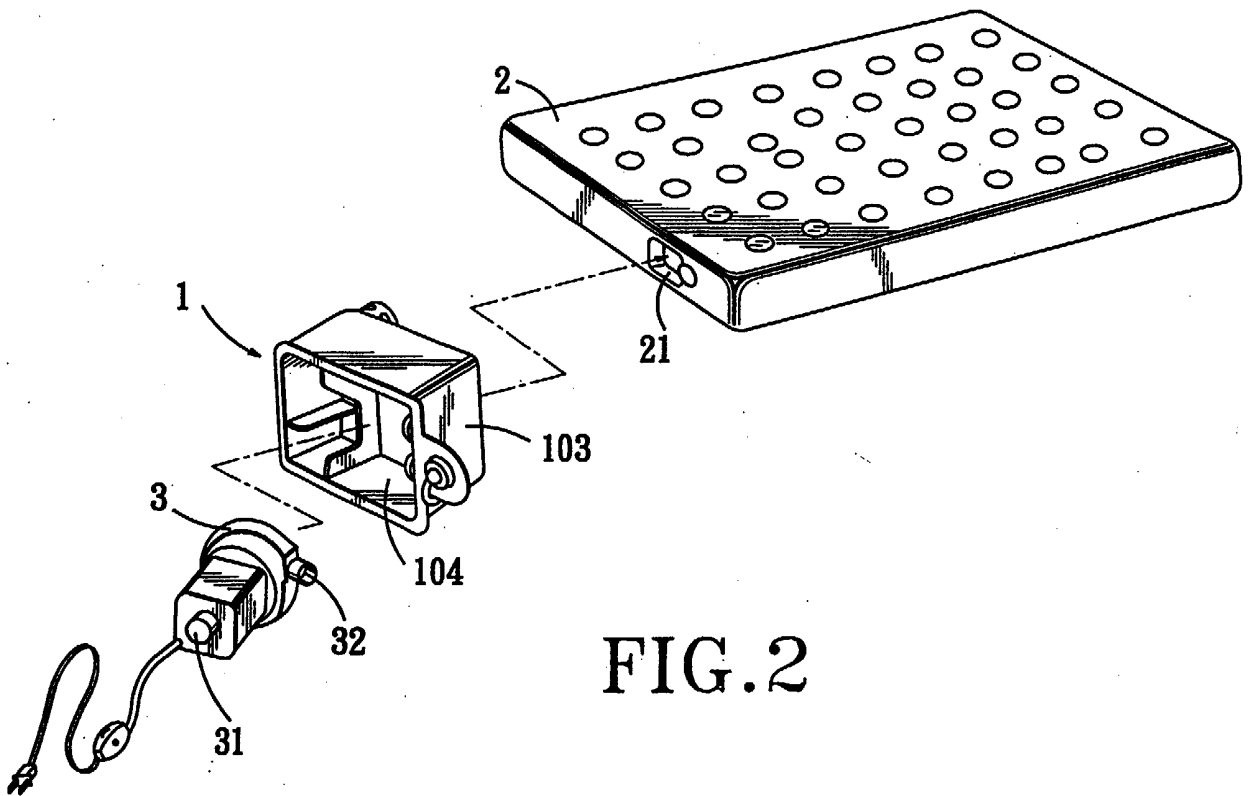
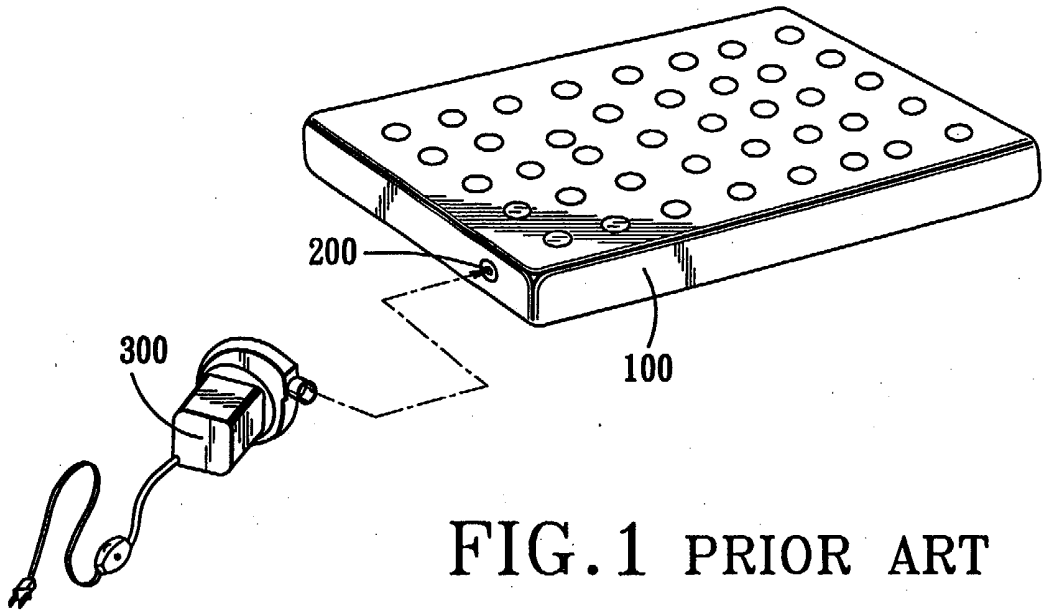

FIG. 4

GB 2 383 824 A



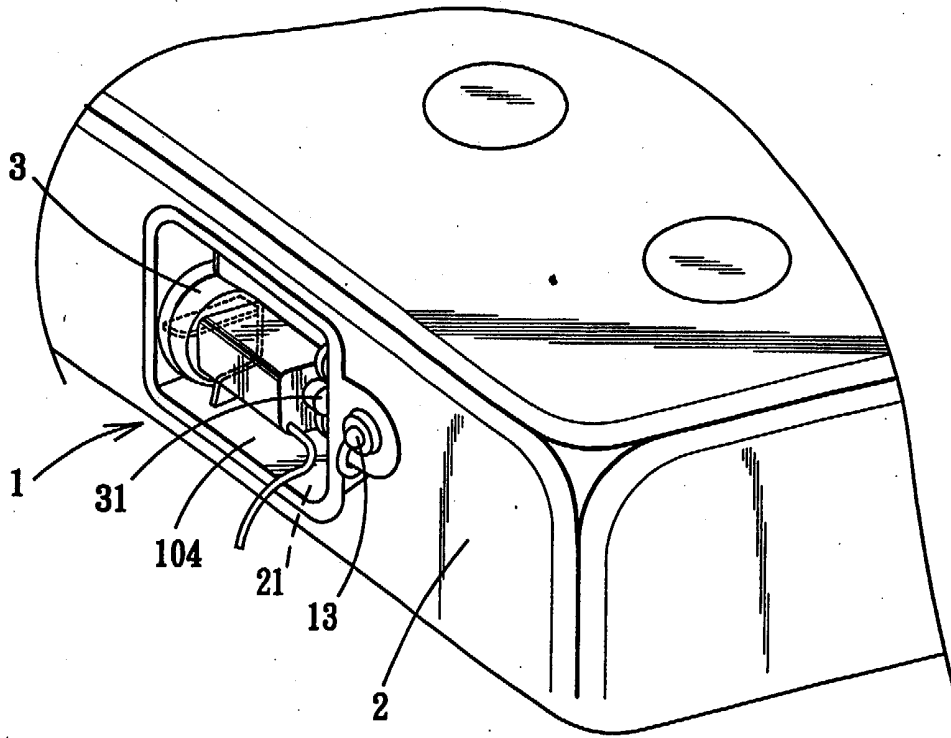

FIG. 3

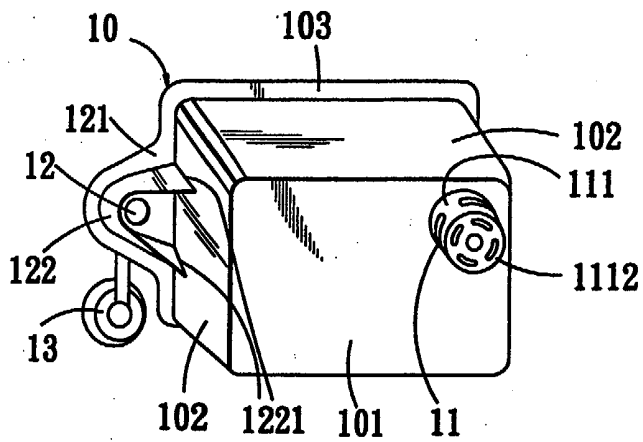

FIG. 4

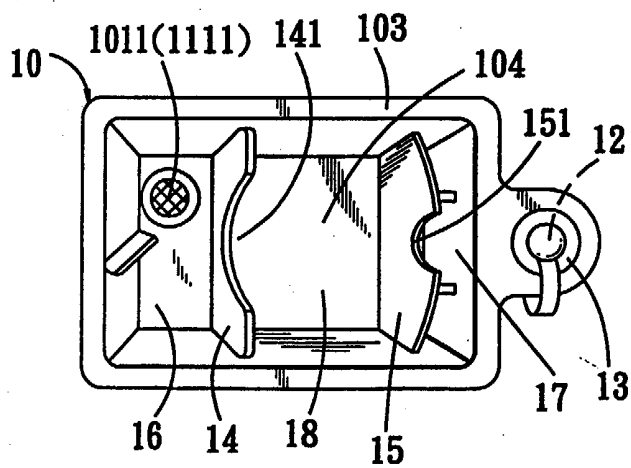

FIG. 5

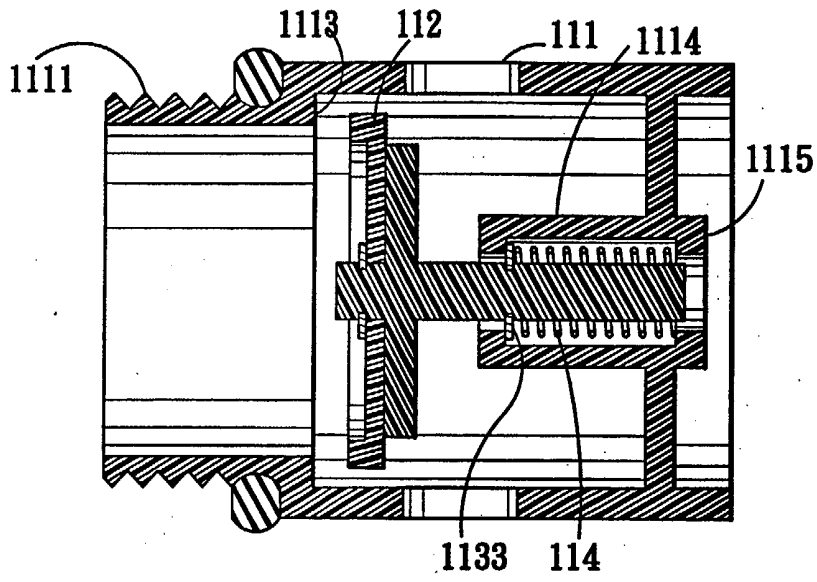

FIG. 6

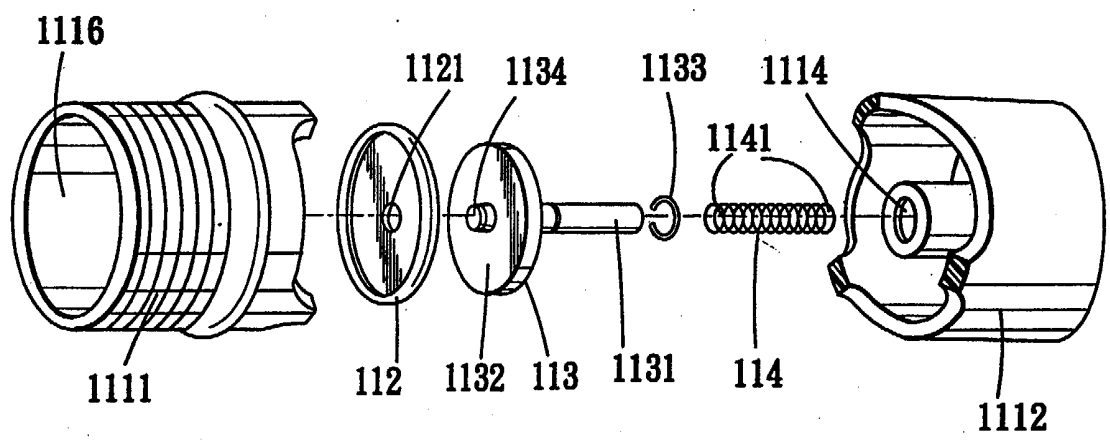

FIG. 7

INFLATION SEAT ASSEMBLY FOR AN INFLATABLE ARTICLE

The invention relates to an inflation seat assembly, more particularly to an inflation seat assembly for connecting an inflatable article to a motor-driven air pump.

Referring to Figure 1, a conventional inflatable article 100 is generally provided with an inflation valve 200. Air is supplied into the inflatable article 100 by blowing or by a motor-driven air pump 300. The inflation valve 200 is a check valve that can prevent the air in the inflatable article 100 from escaping via the inflation valve 200.

Since the inflation valve 200 has a very simple construction, it cannot be relied upon to effectively achieve the purpose of preventing the air in the inflatable article 100 from escaping. Furthermore, since the inflation valve 200 is relatively small, coupling of the air pump 300 to the inflation valve 200 for supplying air into the inflatable article 100 is inconvenient to conduct.

Therefore, the object of the present invention is to provide an inflation seat assembly that is capable of overcoming the aforementioned drawbacks of the prior art.

According to this invention, there is provided an inflation seat assembly adapted for connecting an inflatable article to a motor-driven air pump. The air

pump has an air inlet port and an air outlet port, and is operable so as to draw air via the air inlet port and to supply air via the air outlet port. The inflation seat assembly comprises a casing, an inlet check valve, an air outlet, and a closure member. The casing has a base wall, a peripheral wall extending in a transverse direction from a periphery of the base wall, and a skirt flange extending outwardly from the peripheral wall. The base wall and the peripheral wall cooperate to form a receiving space that is adapted to retain the air pump removably therein. The casing is adapted to be extended into the inflatable article, and is adapted to be connected sealingly to the inflatable article such that the receiving space is accessible externally of the inflatable article. The inlet check valve is disposed on the base wall, is adapted to be coupled to the air outlet port of the air pump, and permits air flow from the air outlet port into the inflatable article for inflating the inflatable article. The air outlet is formed in the skirt flange, and is adapted to be in fluid communication with an interior of the inflatable article. The closure member is mounted on the air outlet for closing selectively the air outlet.

Other features and advantages of the present invention will become apparent in the following detailed description of the preferred embodiment with reference to the accompanying drawings, of which:

Figure 1 is a perspective view of a conventional inflatable article;

Figure 2 is a perspective view of an air inflatable assembly that incorporates the preferred embodiment of an inflation seat assembly according to the present invention;

Figure 3 is a fragmentary perspective view of the air inflatable assembly of Figure 2 in an assembled state;

Figure 4 is a rear perspective view of the air inflatable assembly of Figure 2;

Figure 5 is a schematic front view of the inflation seat assembly of Figure 2;

Figure 6 is a cross-sectional view of an inlet check valve of the inflation seat assembly; and

Figure 7 is an exploded perspective view of the inlet check valve of Figure 6, with a perforated wall portion of a tubular valve housing cut into two for the sake of clarity.

Referring to Figures 2 to 5, the preferred embodiment of an inflation seat assembly 1 according to the present invention is shown to be adapted for use in an air inflatable assembly that includes an inflatable article 2 and a motor-driven air pump 3. The air pump 3 has an air inlet port 31 and an air outlet port 32, and is operable so as to draw air via the air inlet port 31 and to supply air via the air outlet port 32. The inflation seat

assembly 1 comprises a casing 10, an inlet check valve 11, an air outlet 12, and a closure member 13. The casing 10 has a base wall 101, a peripheral wall 102, a skirt flange 103, a pair of partition plates 14, 15, and a reinforcing rib 122, as best illustrated in Figures 4 and 5. The base wall 101 is formed with a mounting hole 1011. The peripheral wall 102 extends in a transverse direction from a periphery of the base wall 101. The base wall 101 and the peripheral wall 102 cooperate to form a receiving space 104 that is adapted to retain the air pump 3 removably therein. The skirt flange 103 extends outwardly from the peripheral wall 102, is disposed on a plane parallel to the base wall 101, and has a projecting section 121 that is formed with the air outlet 12. Each of the partition plates 14, 15 extends from the base wall 101 into the receiving space 104, and divides the receiving space 104 into a first section 16, a second section 17, and a third section 18. The third section 18 is between the first and second sections 16, 17, and is adapted to receive the air pump 3 removably therein. Each of the partition plates 14, 15 further has a distal edge opposite to the base wall 101 and formed with a notch 141, 151. The notches 141, 151 of the partition plates 14, 15 are adapted to permit a respective one of the air inlet and air outlet ports 31, 32 of the air pump 3 to extend removably therethrough. The reinforcing rib 122 extends from the projecting

section 121 along a periphery of the air outlet 12, and has opposite ends 1221 connected to the peripheral wall 102 of the casing 10, thereby reinforcing the projecting section 121 so as to protect the same from breaking.

5 The casing 10 is adapted to be extended into the inflatable article 2 via an opening 21 in the latter, and is adapted to be connected sealingly to the inflatable article 2 such that the receiving space 104 is accessible externally of the inflatable article 2.

10 The inlet check valve 11 is disposed on the base wall 101, is adapted to be coupled removably to the air outlet port 32 of the air pump 3, and permits air flow from the air outlet port 32 into the inflatable article 2 for inflating the inflatable article 2. As shown in
15 Figures 6 and 7, the inlet check valve 11 includes a tubular valve housing 111, a gasket 112, a piston 113, and a biasing member 114. The tubular valve housing 111 has a mounting wall portion 1111, a perforated wall portion 1112, an annular valve seat 1113, and a shaft
20 guiding tube 1114. The mounting wall portion 1111 is mounted threadedly to the base wall 101 at the mounting hole 1011, and confines a coupling hole 1116 for coupling with the air outlet port 32 of the air pump 3. The perforated wall portion 1112 extends from the mounting
25 wall portion 1111. The annular valve seat 1113 is formed at a juncture of the mounting and perforated wall portions 1111, 1112. The shaft guiding tube 1114 is

connected to and is disposed coaxially in the perforated wall portion 1112, and has one end formed with a radial inward spring support flange 1115. The gasket 112 is disposed in the perforated wall portion 1112, and has a through-hole 1121. The piston 113 has a piston shaft 1131 and an urging plate 1132. The piston shaft 1131 extends slidably into the shaft guiding tube 1114, and has a spring support ring 1133 mounted thereon. The urging plate 1132 is formed on one end of the piston shaft 1131, and has a protrusion 1134 that extends into the through-hole 1121 in the gasket 112. The urging plate 1132 is disposed on one side of the gasket 112 opposite to the valve seat 1113. The biasing member 114 is a coil spring sleeved on the piston shaft 1131, is disposed in the shaft guiding tube 1114, and has opposite ends 1141 abutting against the spring support flange 1115 and the spring support ring 1133, respectively, thereby biasing the piston 113 to push the gasket 112 to seal the valve seat 1113, and thereby preventing the air in the inflatable article 2 from escaping via the inlet check valve 11.

The air outlet 12, which is formed in the skirt flange 103, is adapted to be in fluid communication with an interior of the inflatable article 2, and is adapted to be coupled removably to the air inlet port 31 of the air pump 3.

The closure member 19 is mounted on the air outlet

12 for closing selectively the air outlet 12.

In use, the air outlet port 32 of the air pump 3 is coupled to the valve housing 111 of the inlet check valve 11 so that air flow from the former pushes the gasket 112 and the piston 113 against the action of the biasing member 114, and enters into the inflatable article 2 via the perforated wall portion 1112 of the valve housing 111, thereby inflating the article 2. To deflate the article 2, the closure member 19 is removed from the air outlet 12, and the air inlet port 31 of the air pump 3 is coupled to the air outlet 12 so as to draw air from the article 2.

It has thus been shown that the inlet check valve 11 on the casing 10 can effectively guard against the undesired escape of air from the article 2. In addition, the inlet check valve 11 and the air outlet 12 can be coupled to the air pump 3 to facilitate inflation and deflation of the article 2. The object of the present invention is thus achieved.

CLAIMS:

1. An inflation seat assembly for connecting an inflatable article to a motor-driven air pump, the air pump having an air inlet port and an air outlet port and being operable so as to draw air via the air inlet port and to supply air via the air outlet port, said inflation seat assembly comprising:

a casing having a base wall, a peripheral wall extending in a transverse direction from a periphery of said base wall, and a skirt flange extending outwardly from said peripheral wall, said base wall and said peripheral wall cooperating to form a receiving space that is adapted to retain the air pump removably therein, said casing being adapted to be extended into the inflatable article and being adapted to be connected sealingly to the inflatable article such that said receiving space is accessible externally of the inflatable article;

an inlet check valve disposed on said base wall, said inlet check valve being adapted to be coupled to the air outlet port of the air pump and permitting air flow from the air outlet port into the inflatable article for inflating the inflatable article;

an air outlet formed in said skirt flange and adapted to be in fluid communication with an interior of the inflatable article; and

a closure member mounted on said air outlet for

closing selectively said air outlet.

2. The inflation seat assembly of Claim 1, wherein said casing further has a pair of partition plates, each of which extends from said base wall into said receiving space so as to divide said receiving space into a first section, a second section, and a third section between said first and second sections and adapted to receive the air pump therein, each of said partition plates having a distal edge opposite to said base wall and formed with a notch, said notches of said partition plates being adapted to permit a respective one of the air inlet and air outlet ports of the air pump to extend removably therethrough.

3. The inflation seat assembly of Claim 1, wherein said skirt flange has a projecting section that is formed with said air outlet, said casing further having a reinforcing rib that extends from said projecting section along a periphery of said air outlet and that has opposite ends connected to said peripheral wall of said casing.

4. The inflation seat assembly of Claim 1, wherein said base wall is formed with a mounting hole, said inlet check valve including:

a tubular valve housing having a mounting wall portion coupled to said base wall at said mounting hole, a perforated wall portion extending from said mounting wall portion, an annular valve seat formed at a juncture

of said mounting and perforated wall portions, and a shaft guiding tube connected to and disposed coaxially in said perforated wall portion;

a gasket disposed in said perforated wall portion;

5 a piston having a piston shaft that extends slidably into said shaft guiding tube, and an urging plate formed on one end of said piston shaft and disposed on one side of said gasket opposite to said valve seat; and

10 a biasing member disposed in said shaft guiding tube for biasing said piston to push said gasket to seal said valve seat, thereby preventing the air in the inflatable article from escaping via said inlet check valve.

5. The inflation seat assembly of Claim 4, wherein said shaft guiding tube has one end formed with a radial inward spring support flange, said piston shaft having a spring support ring mounted thereon, said biasing member being
15 a coil spring sleeved on said piston shaft and having opposite ends abutting against said spring support flange and said spring support ring, respectively.

20 6. The inflation seat assembly of Claim 1, wherein said skirt flange is disposed on a plane that is parallel to said base wall of said casing.

25 7. The inflation seat assembly of Claim 1, wherein said air outlet is adapted to be coupled removably to the air inlet port of the air pump.

8. The inflation seat assembly substantially as hereinbefore described with reference to and as

illustrated in Figures 2-7 of the accompanying drawings.

CLAIMS:

1. An inflation seat assembly for connecting an inflatable article to a motor-driven air pump, the air pump having an air inlet port and an air outlet port and being operable so as to draw air via the air inlet port and to supply air via the air outlet port, said inflation seat assembly comprising:

a casing having a base wall, a peripheral wall extending in a transverse direction from a periphery of said base wall, and a skirt flange extending outwardly from said peripheral wall, said base wall and said peripheral wall cooperating to form a receiving space that is adapted to retain the air pump removably therein, said casing being adapted to be extended into the inflatable article and being adapted to be connected sealingly to the inflatable article such that said receiving space is accessible externally of the inflatable article;

an inlet check valve disposed on said base wall, said inlet check valve being adapted to be coupled to the air outlet port of the air pump and permitting air flow from the air outlet port into the inflatable article for inflating the inflatable article;

an air outlet formed in said skirt flange and adapted to be in fluid communication with an interior of the inflatable article; and

a closure member mounted on said air outlet for

closing selectively said air outlet; wherein said base wall is formed with a mounting hole, said inlet check valve including:

a tubular valve housing having a mounting wall portion coupled to said base wall at said mounting hole, a perforated wall portion extending from said mounting wall portion, an annular valve seat formed at a juncture of said mounting and perforated wall portions, and a shaft guiding tube connected to and disposed coaxially in said perforated wall portion;

a gasket disposed in said perforated wall portion;

a piston having a piston shaft that extends slidably into said shaft guiding tube, and an urging plate formed on one end of said piston shaft and disposed on one side of said gasket opposite to said valve seat; and

a biasing member disposed in said shaft guiding tube for biasing said piston to push said gasket to seal said valve seat, thereby preventing the air in the inflatable article from escaping via said inlet check valve.

2. The inflation seat assembly of Claim 1, wherein said casing further has a pair of partition plates, each of which extends from said base wall into said receiving space so as to divide said receiving space into a first section, a second section, and a third section between said first and second sections and adapted to receive the air pump therein, each of said partition plates having a distal edge opposite to said base wall and formed with a notch, said notches of said partition plates being

adapted to permit a respective one of the air inlet and air outlet ports of the air pump to extend removably therethrough.

3. The inflation seat assembly of Claim 1, wherein said skirt flange has a projecting section that is formed with said air outlet, said casing further having a reinforcing rib that extends from said projecting section along a periphery of said air outlet and that has opposite ends connected to said peripheral wall of said casing.

4. The inflation seat assembly of Claim 1, wherein said shaft guiding tube has one end formed with a radial inward spring support flange, said piston shaft having a spring support ring mounted thereon, said biasing member being a coil spring sleeved on said piston shaft and having opposite ends abutting against said spring support flange and said spring support ring, respectively.

5. The inflation seat assembly of Claim 1, wherein said skirt flange is disposed on a plane that is parallel to said base wall of said casing.

6. The inflation seat assembly of Claim 1, wherein said air outlet is adapted to be coupled removably to the air inlet port of the air pump.

7. The inflation seat assembly substantially as hereinbefore described with reference to and as

illustrated in Figures 2-7 of the accompanying drawings.



INVESTOR IN PEOPLE

Application No: GB 0200173.3
Claims searched: 1 - 8

Examiner: David Hotchkiss
Date of search: 26 June 2002

Patents Act 1977 Search Report under Section 17

Databases searched:

UK Patent Office collections, including GB, EP, WO & US patent specifications, in:
UK Cl (Ed.T): F1W (WAB, WEX, W104); B7A (AAAJ, AAAT, A424); A4M (M1B2, M1B6); F2V (VW22, VV8, VV3, VG10)
Int Cl (Ed.7): F04B (19/00, 17/00); A47C (27/08); F04D29/60
Other: Online: WPI; EPODOC; JAPIO

Documents considered to be relevant:

Category	Identity of document and relevant passage	Relevant to claims
X	WO 01/87121 (CHAFFEE R B) See especially figures 2 - 5 & 9	1 & 6
X	US 2001044969 (CHAFFEE R B) See especially figures 2 - 5 & 9	1 & 6
X	US 2001026763 (TEAM WORLDWIDE CORP) See especially figure 2	1 & 6
X	US 6332760 (TEAM WORLDWIDE CORP) See especially figure 2	1 & 6

X	Document indicating lack of novelty or inventive step	A	Document indicating technological background and/or state of the art.
Y	Document indicating lack of inventive step if combined with one or more other documents of same category.	P	Document published on or after the declared priority date but before the filing date of this invention.
&	Member of the same patent family	E	Patent document published on or after, but with priority date earlier than, the filing date of this application.