



US 20050159746A1

(19) **United States**

(12) **Patent Application Publication**

Grob et al.

(10) **Pub. No.: US 2005/0159746 A1**

(43) **Pub. Date: Jul. 21, 2005**

(54) **CERVICAL FACET RESURFACING IMPLANT**

Publication Classification

(76) Inventors: **Dieter Grob, Erlenbach (CH); Horace Winston Hale, Degersheim (CH)**

(51) **Int. Cl.7** **A61B 17/56**

(52) **U.S. Cl.** **606/61**

Correspondence Address:

**Mark C. Johnson
Renner, Otto, Boisselle & Sklar, LLP
Nineteenth Floor
1621 Euclid Avenue
Cleveland, OH 44115-2191 (US)**

(57) **ABSTRACT**

The present invention relates to prostheses for treating spinal pathologies, and more specifically to a system and method for treating articulating surfaces of cervical vertebrae facet joints. The system includes a superior implant for placement on a superior articulating surface and an inferior implant for placement on an inferior articulating surface. In addition, described is a method for providing articulating surfaces for cervical vertebrae facet joint articular facets.

(21) Appl. No.: **10/762,008**

(22) Filed: **Jan. 21, 2004**

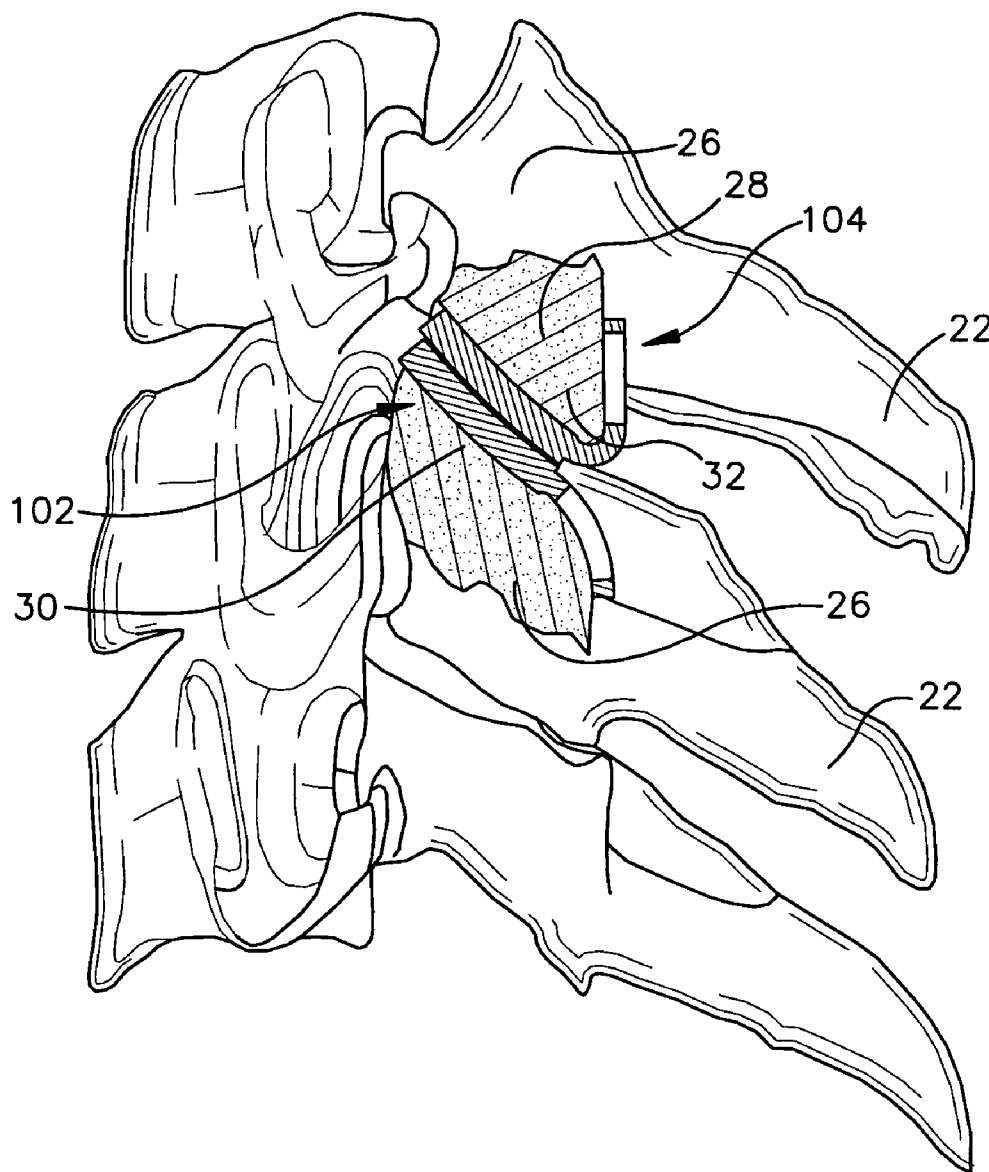

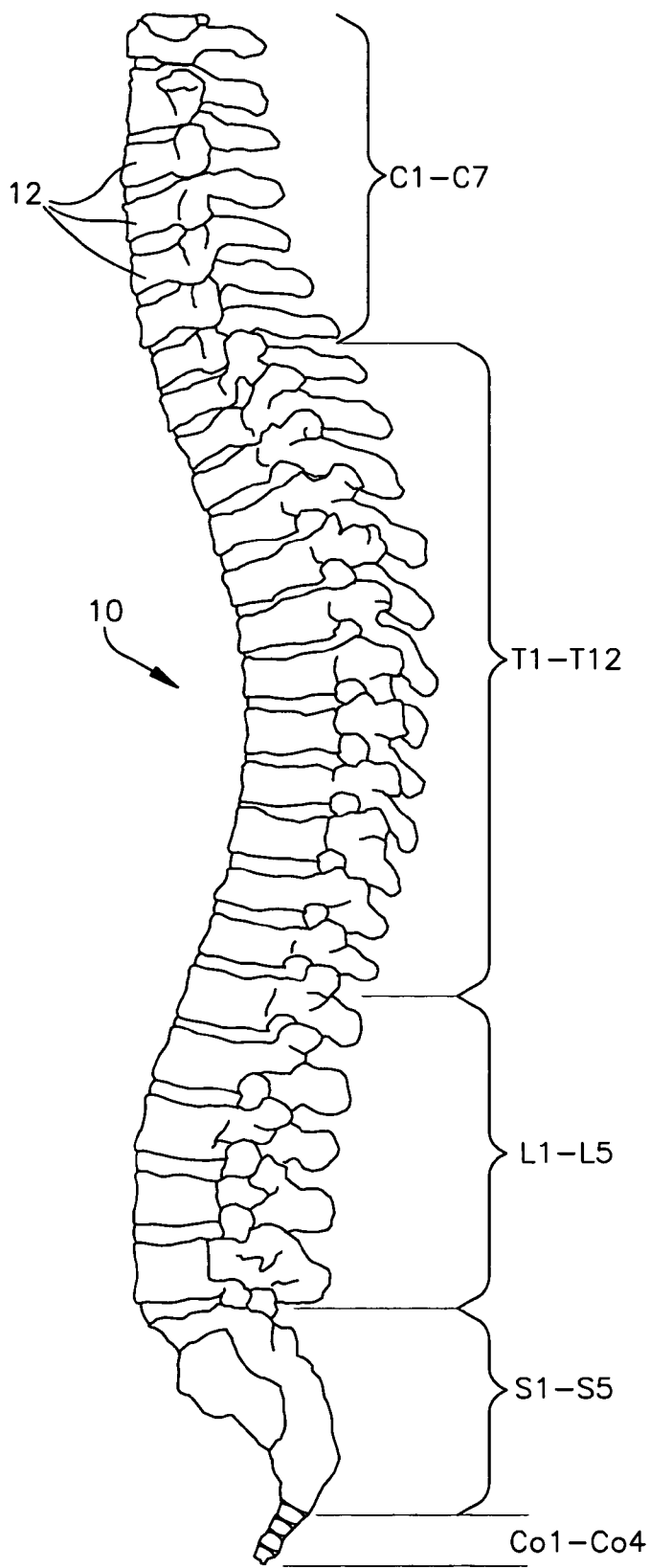

Figure 1

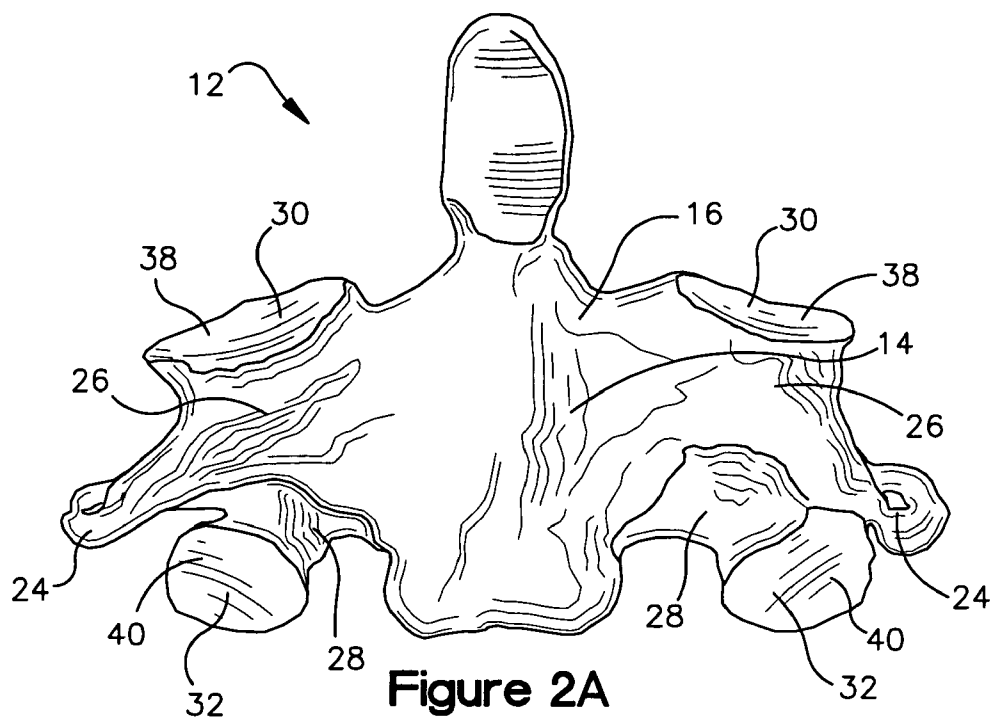

Figure 2A

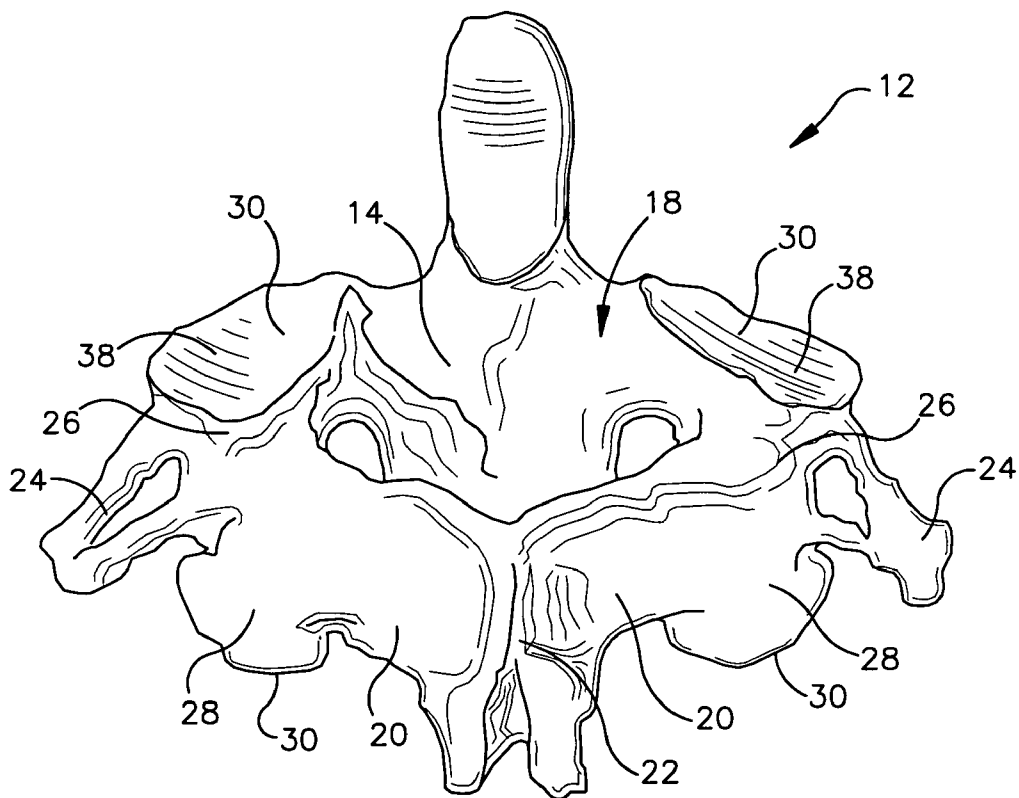

Figure 2B

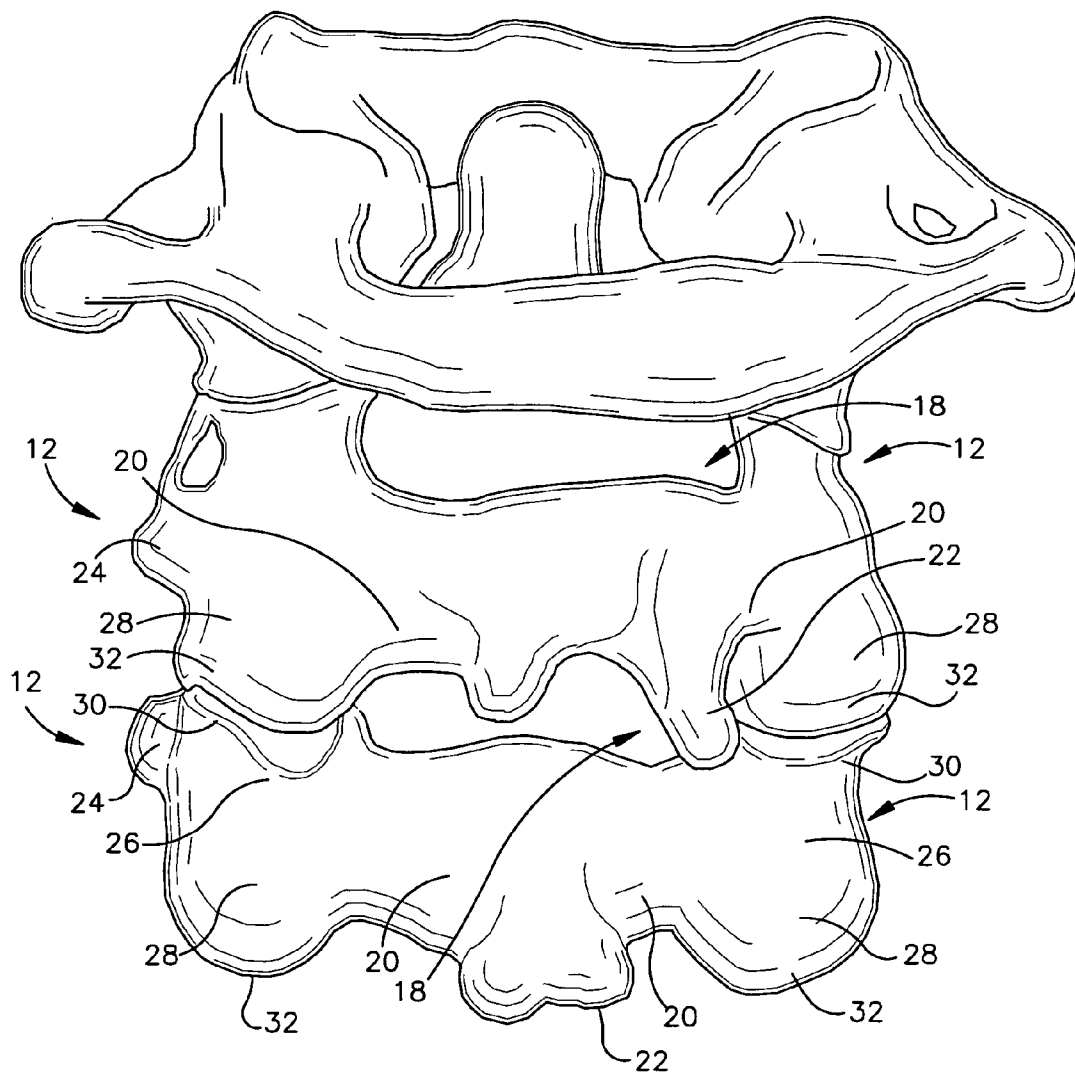

Figure 3

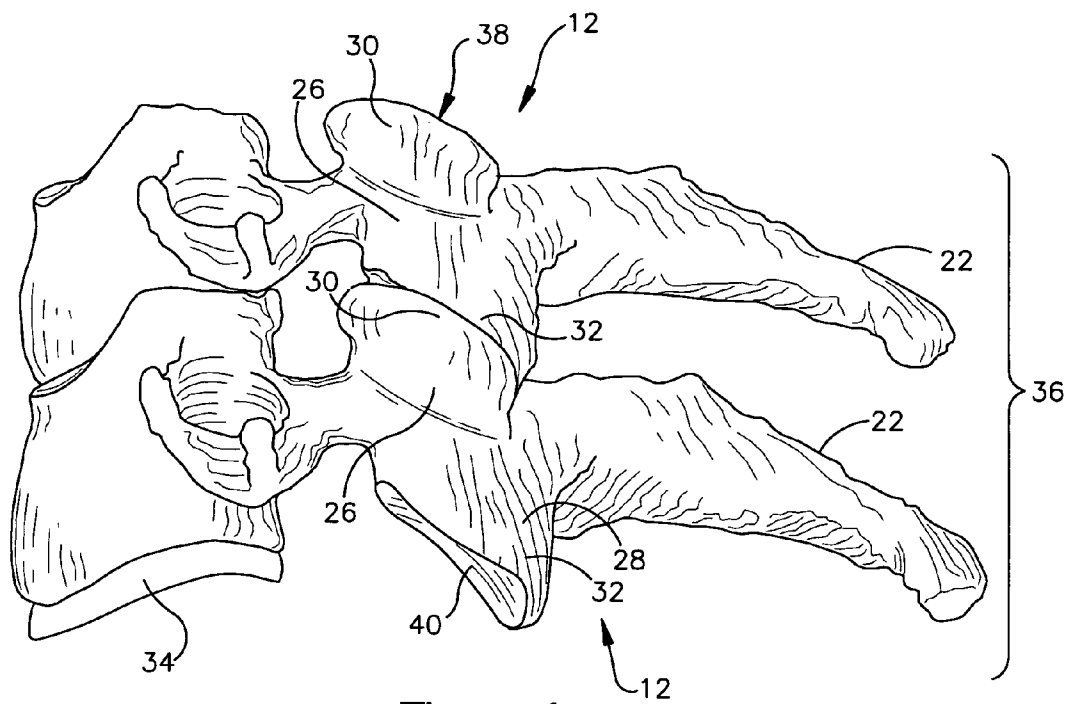

Figure 4

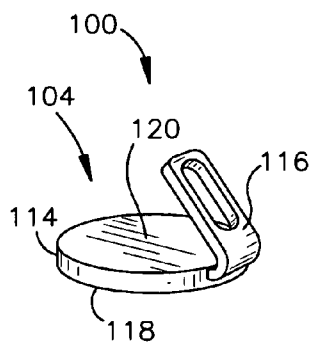

Figure 5A

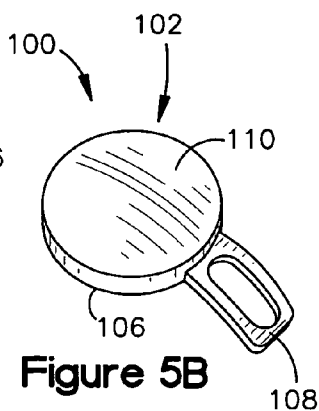

Figure 5B

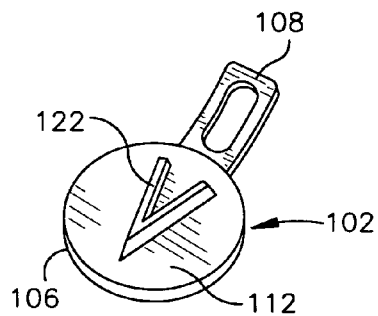

Figure 5C

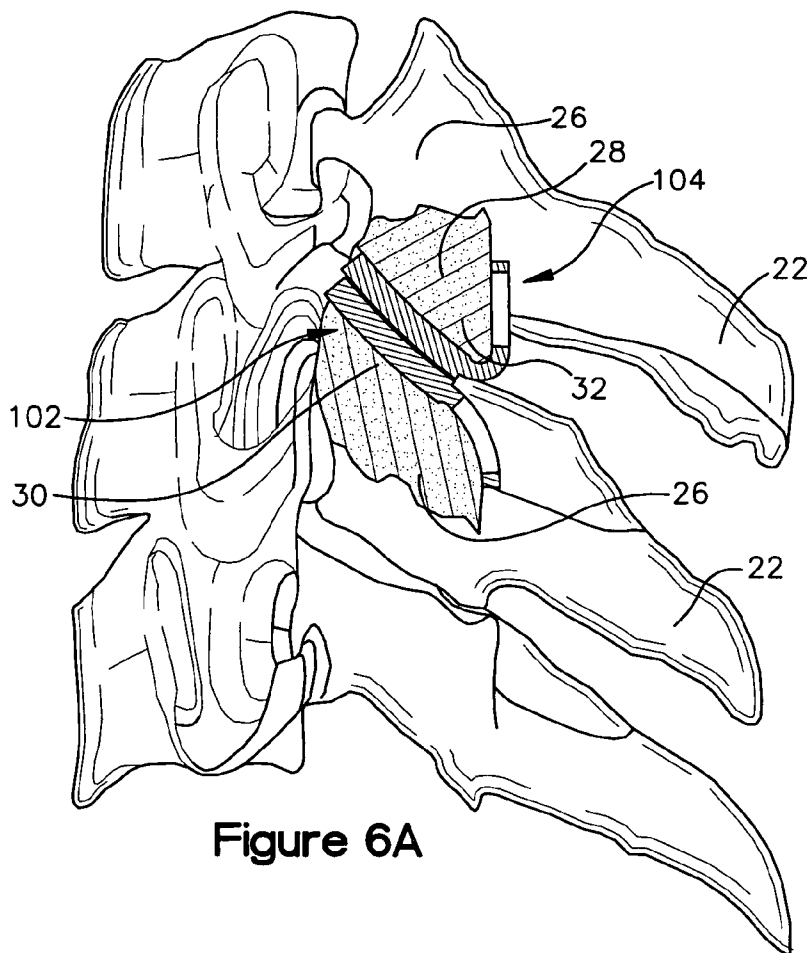

Figure 6A

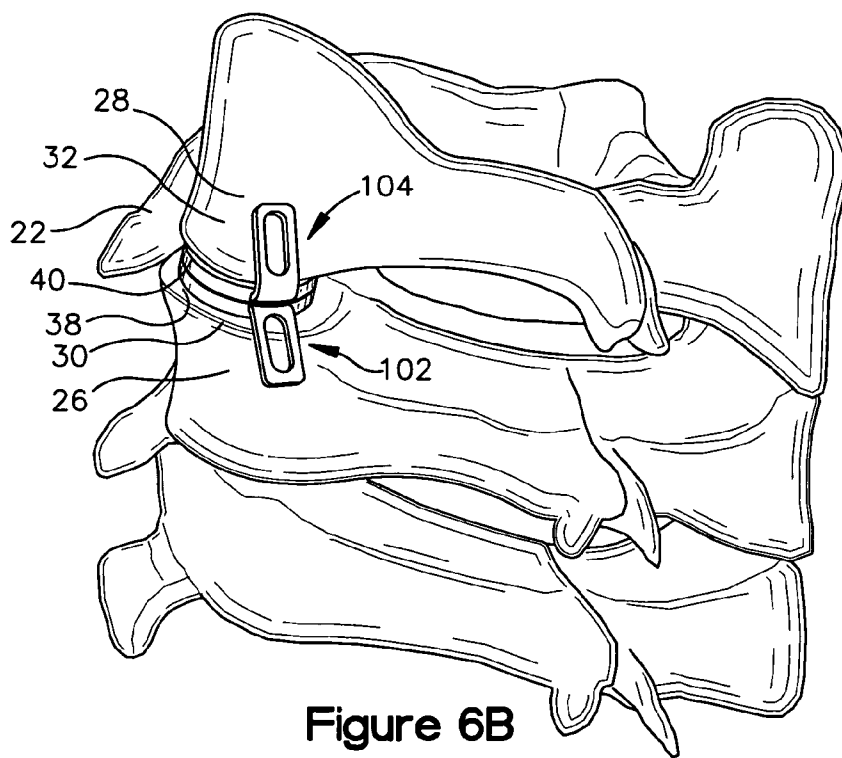

Figure 6B

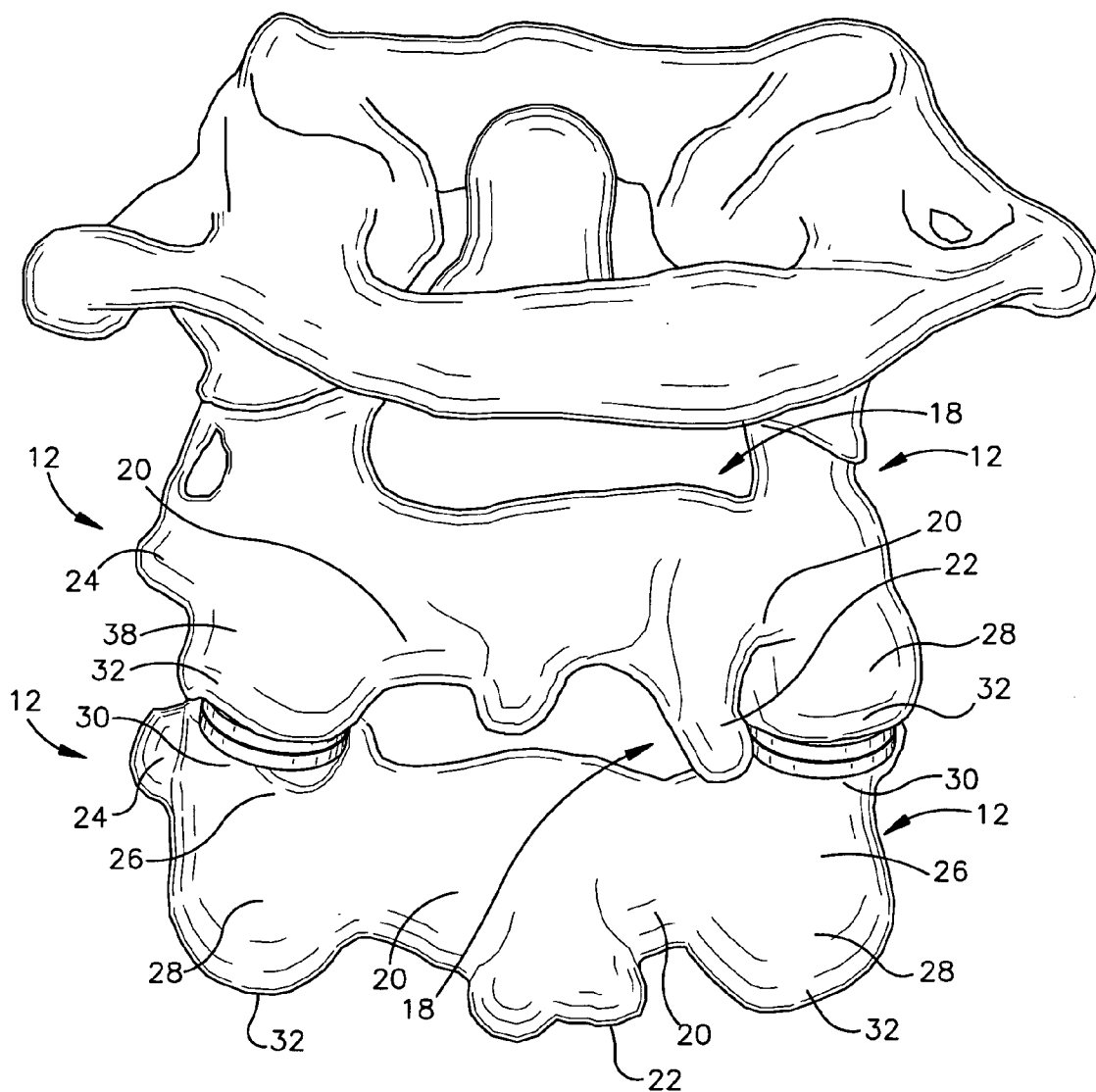

Figure 6

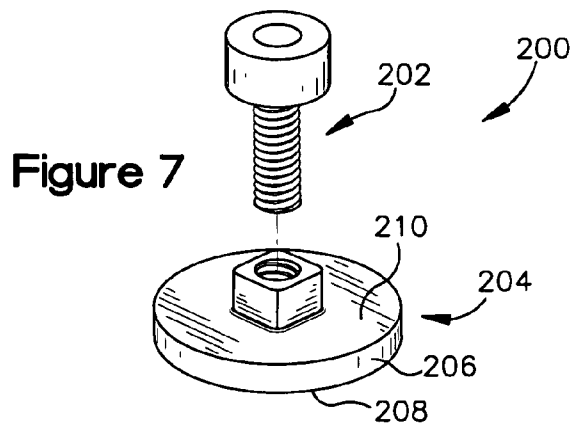

Figure 7

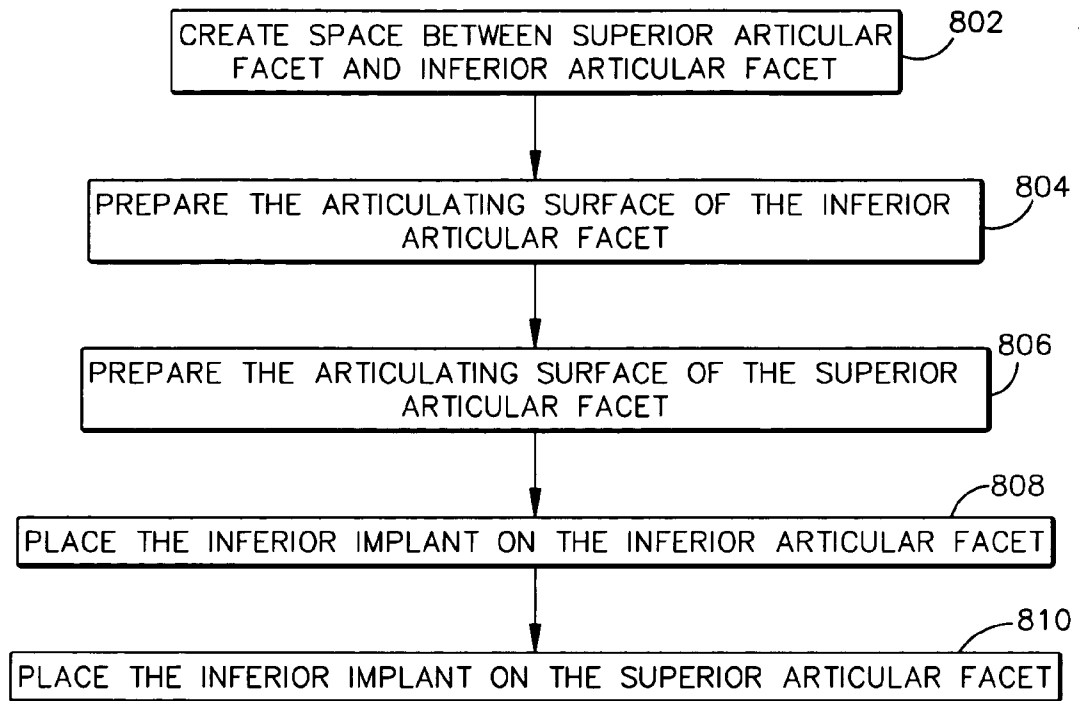

Figure 8

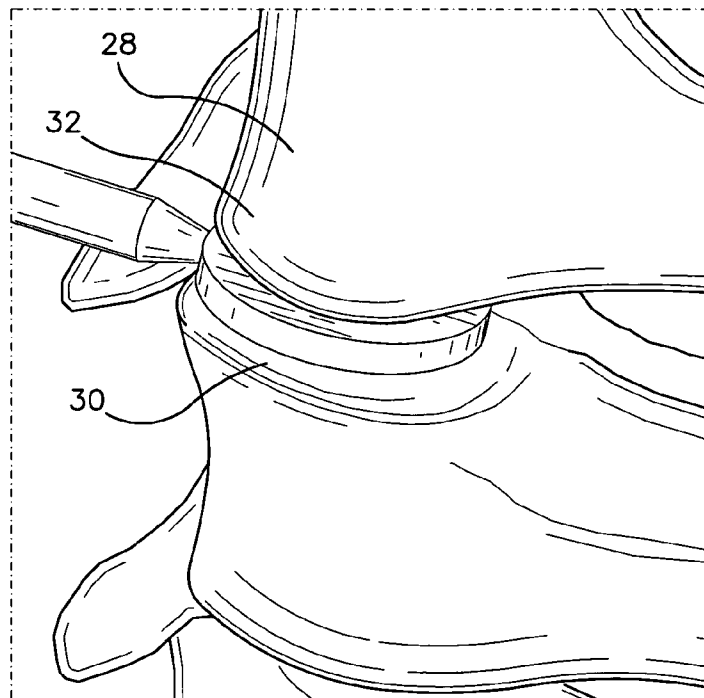

Figure 9

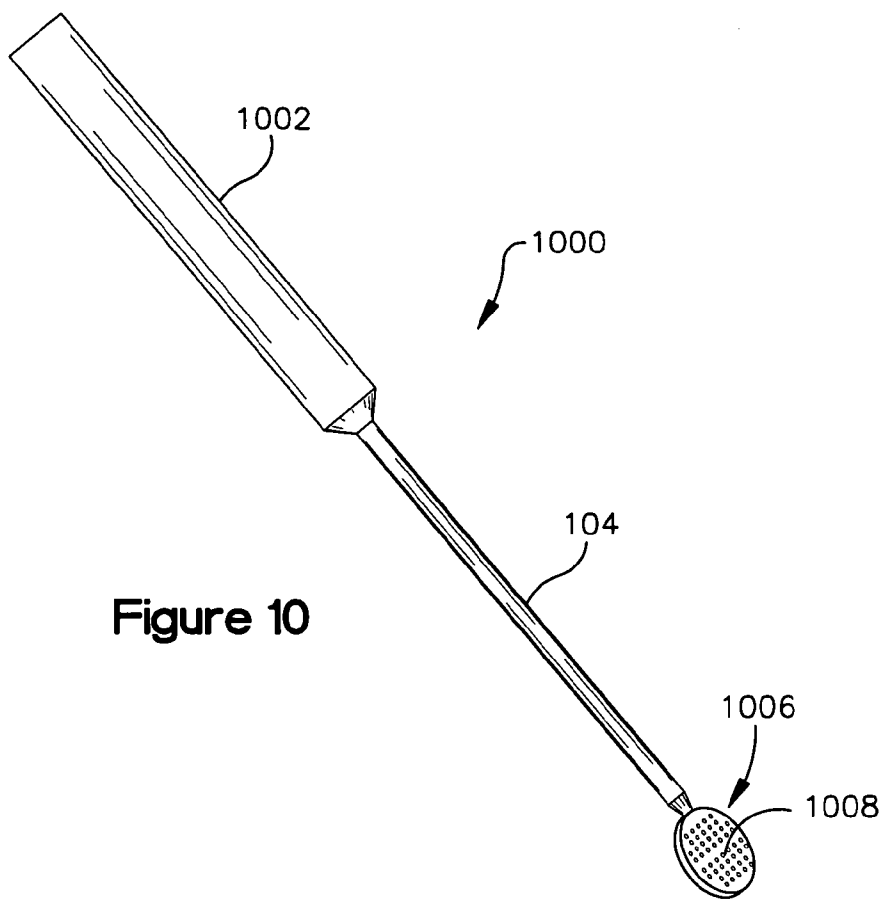

Figure 10

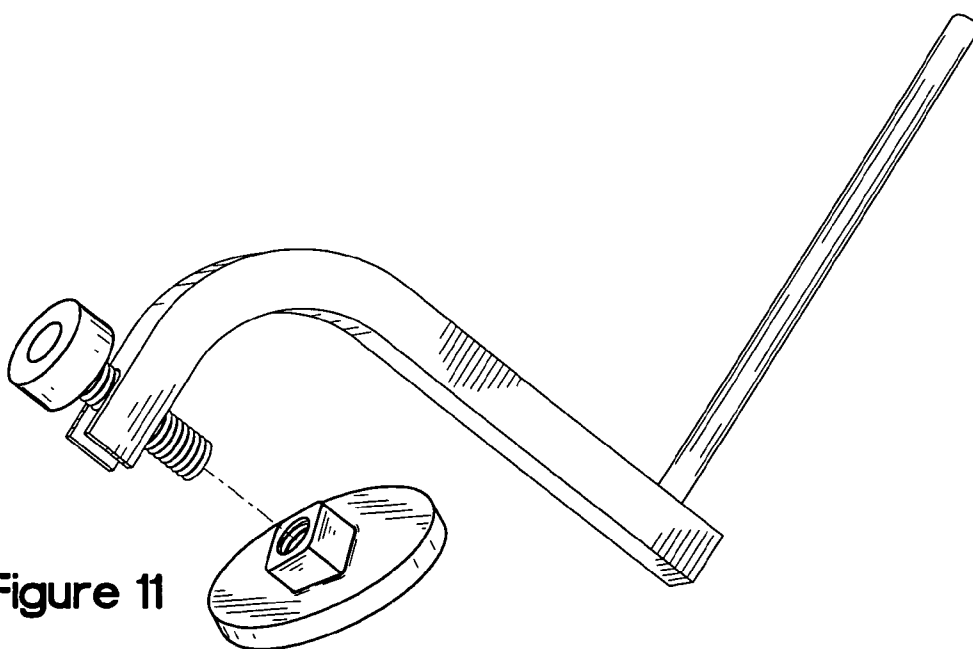

Figure 11

CERVICAL FACET RESURFACING IMPLANT

FIELD OF THE INVENTION

[0001] The present invention relates generally to prostheses for treating spinal pathologies, and more specifically to a system and method for treating articulating surfaces of cervical facet joints.

BACKGROUND OF THE INVENTION

[0002] Back and neck pain are common ailments. In many cases, the pain severely limits a person's functional ability and quality of life. A variety of spinal pathologies can lead to back pain.

[0003] Through disease or injury, the laminae, spinous process, articular processes, or facets of one or more vertebral bodies can become damaged, such that the vertebrae no longer articulate or properly align with each other. This can result in an undesired anatomy, loss of mobility, and pain or discomfort. With respect to vertebral articular surface degeneration, facet joints may show a reduced thickness of cartilage and may advance to entire disappearance thereof. Furthermore, surrounding the degenerated articular surfaces, there is bony formation capable of causing neurological compressions inside either the foramenae or spinal canal. These facts induce pain which affect a large part of the population.

[0004] The vertebral facet joints, for example, can be damaged by either traumatic injury or by various disease processes, such as osteoarthritis, ankylosing spondylolysis, and degenerative spondylolisthesis. The damage to the facet joints often results in pressure on nerves, also called a "pinched" nerve, or nerve impingement. The result is pain, misaligned anatomy, and a corresponding loss of mobility. Pressure on nerves can also occur without facet joint pathology, e.g., a herniated disc.

[0005] Degenerative spinal diseases can involve articular surfaces only, but may also have a more invasive pathology including traumatic, infectious, tumorous or dysmorphic (spondylolisthesis, for example) effecting the destruction of all or part of the articular process. The locking of vertebral motions by spinal arthrodesis or ligamentoplasty induces, beyond a spinal stiffness, an increased force on the joint facets of the adjacent vertebrae above and below the fusion, usually sustained by the considered intervertebral space and therefore an increase of degeneration of these joint facets.

[0006] One type of conventional treatment of facet joint pathology is spinal stabilization, also known as intervertebral stabilization. By applying intervertebral stabilization, one can prevent relative motion between the vertebrae. By preventing this movement, pain can be reduced. Stabilization can be accomplished by various methods. One method of stabilization is spinal fusion. Another method of stabilization is fixation of any number of vertebrae to stabilize and prevent movement of the vertebrae. Yet another type of conventional treatment is decompressive laminectomy. This procedure involves excision of the laminae to relieve compression of nerves. With regard to discal prostheses, they provide a "space" between two vertebral bodies while preserving some motion. They solve the aging intervertebral disc problem but do not function to reduce the force on posterior joint facets.

[0007] These traditional treatments are subject to a variety of limitations and varying success rates. Furthermore, none of the described treatments puts the spine in proper alignment or returns the spine to a desired anatomy. In addition, stabilization techniques, by holding the vertebrae in a fixed position, permanently limit a person's mobility. Some procedures involving motion devices have a high incidence of spontaneous fusion. There is thus a need in the art for a system and procedure capable of increasing the percentage of good results in disc replacement surgery. In addition, there is a need in the art for better results than are commonly achieved through spinal fusions. Further, there is a need in the art for a system and procedure that permits greater mobility in cases of spinal problems involving only the facet joints, and for obviating the need for spinal fusion associated with degenerative and congenital problems of the spine.

BRIEF SUMMARY OF THE INVENTION

[0008] According to an aspect of the invention, there is provided a cervical facet resurfacing implant comprising: a superior implant having an articulating surface and a fixation surface and configured for secured placement on a resurfaced superior articular facet of a selected cervical vertebra; and an inferior implant having an articulating surface and a fixation surface and configured for secured placement on a resurfaced inferior articular facet of a cervical vertebra immediately above the selected cervical vertebra such that the articulating surface of the inferior implant interacts with the articular surface of the superior implant.

[0009] According to another aspect of the invention, there is provided a facet implant comprising: a generally disk-shaped superior implant having an articulating surface and a fixation surface and being configured for placement on a resurfaced superior articular facet of a selected cervical vertebra, the superior implant having a tab extending from the generally disk-shaped portion of the superior implant, the tab being configured for secured attachment to the lateral mass of the selected vertebra; and a generally disk-shaped inferior implant having an articulating surface and a fixation surface and being configured for placement on a resurfaced inferior articular facet of a cervical vertebra immediately above the selected cervical vertebra such that the articulating surface of the inferior implant interacts with the articular surface of the superior implant, the inferior implant having a tab extending from the generally disk-shaped portion of the inferior implant, the tab being configured for secured attachment to the inferior articular process of the cervical vertebra immediately above the selected vertebra.

[0010] According to another aspect of the invention, there is a method for providing articulating surfaces for cervical vertebrae facet joint articular facets comprising of: creating a space between a superior articular facet of a selected cervical vertebra and an inferior articular facet of a cervical vertebra immediately above the selected cervical vertebra; using a rasp to prepare an articulating surface of the inferior articular facet for an inferior implant; using a rasp to prepare an articulating surface of the superior articular facet for a superior implant; fixing the inferior implant on the inferior articular facet such that a fixation surface of the inferior implant interacts with the articulating surface of the inferior articular facet; and fixing the superior implant on the superior articular facet such that a fixation surface of the superior implant interacts with the articulating surface of the superior

articular facet; wherein the articulating surface of the superior implant and the articulating surface of the inferior implant are configured to articulate with one another.

BRIEF DESCRIPTION OF THE DRAWINGS

- [0011] FIG. 1 is a lateral elevation view of a normal human spinal column;
- [0012] FIG. 2A is an anterior view of a normal human cervical vertebra;
- [0013] FIG. 2B is a posterosuperior view of a normal human cervical vertebra;
- [0014] FIG. 3 is a posterior perspective view of a cervical vertebral facet joint;
- [0015] FIG. 4 is a lateral elevation view of a cervical vertebral facet joint;
- [0016] FIG. 5 illustrates a cervical facet implant;
- [0017] FIGS. 6A-C illustrate a facet implant in conjunction with cervical vertebrae;
- [0018] FIG. 7 illustrates an alternate embodiment of a cervical facet inferior implant in conjunction with a trans-lateral mass screw;
- [0019] FIG. 8 is a flow chart generally illustrating a method for providing articulating surfaces for cervical facet joint articular facets;
- [0020] FIG. 9 is an illustration of a rasp being used to prepare an articulating surface;
- [0021] FIG. 10 is an illustration of a rasp; and
- [0022] FIG. 11 is an illustration of an aiming device for use in positioning a trans lateral mass screw.

DETAILED DESCRIPTION OF THE INVENTION

[0023] Referring initially to FIG. 1, the human spinal column 10 is illustrated. The spinal column 10 is comprised of a series of thirty-three stacked vertebrae divided into five regions. The cervical region includes seven vertebrae, known as C1-C7. The thoracic region includes twelve vertebrae, known as T1-T12. The lumbar region contains five vertebrae, known as L1-L5. The sacral region is comprised of five vertebrae, known as S1-S5. The coccygeal region contains four vertebrae 12, known as Co1-Cu4.

[0024] Turning now to FIGS. 2 and 3, normal human cervical vertebrae 12 are illustrated. It will be understood by those skilled in the art that while the cervical vertebrae 12 vary somewhat according to location, they share many features common to most vertebrae 12. Each vertebra 12 includes a vertebral body 14. Two short bones, the pedicles 16, extend backward from each side of the vertebral body 14 to form a vertebral arch 18. At the posterior end of each pedicle 16, the vertebral arch 18 flares out into broad plates of bone known as the laminae 20. The laminae 20 fuse with each other to form a spinous process 22. The spinous process 22 provides muscle and ligament attachment.

[0025] The transition from the pedicles 16 to the laminae 20 is interrupted by a transverse process 24 that thrust out laterally on each side from the junction of the pedicle 16 and the lamina 20. The transverse processes 24 serve as guides

for the attachment of muscles to the vertebrae 12. Connecting the transverse process 24 on each side of the body 14 is a lateral mass 26. Two inferior articular processes 28 extend downward from the junction of the laminae 20 and the transverse processes 24. The inferior articular processes 28 each have a natural bony structure known as an inferior articular facet 32, which faces downward. On the superior articular facet 30 is a superior articulating surface 38. Similarly, a superior articular facet 30 faces upward from the junction of the lateral mass 26 and the pedicle 16. On the inferior articular facet 32 is an inferior articulating surface 40.

[0026] As shown in FIGS. 3 and 4, when adjacent vertebrae 12 are aligned, the superior articular facet 30 and inferior articular facet 32 interlock. Capped with a smooth articular cartilage, the interlocked vertebrae form a facet joint 36, also known as a zygapophysial joint. An intervertebral disc 34 between each pair of vertebrae 12 permits gliding movement between vertebrae 12. Thus, the structure and alignment of the vertebrae 12 permit a range of movement of the vertebrae 12 relative to each other.

[0027] The facet joint 36 is composed of a superior half and an inferior half. The superior half is formed by the vertebral level below the intervertebral disc 34, and the inferior half is formed by the vertebral level above the intervertebral disc 34. For example, in the C3-C4 facet joint, the superior portion of the joint is formed by bony structure on the C4 vertebra (e.g., a superior articular surface and supporting bone on the C4 vertebra), and the inferior portion of the joint is formed by bony structure on the C3 vertebra (e.g., an inferior articular surface and supporting bone on the C3 vertebra).

[0028] Turning now to FIG. 5, an exemplary cervical facet resurfacing implant according to the present invention is illustrated. The exemplary facet implant 100 generally has a superior implant 102 and an inferior implant 104. The superior implant 102 generally has a disk-shaped portion 106 and a tab 108 extending from the disk-shaped portion 106. The disk-shaped portion 106 includes an articulating surface 110 and a fixation surface 112.

[0029] The inferior implant 104 also generally has a disk-shaped portion 114 and a tab 116 extending from the disk-shaped portion 114. The disk-shaped portion 114 includes an articulating surface 118 and a fixation surface 120.

[0030] It should be noted that the term "disk-shaped" is not restricted to circular or ovalar shapes. A generally disk-shaped implant may have multiple sides, such as a square-shaped, hexagonal-shaped, or octagonal-shaped implant. While each of these shapes appear similar from a lateral perspective and are capable of performing a similar function according to the present invention, a circular or ovalar disk-shape is preferred.

[0031] Turning now to FIGS. 6A-C, an exemplary cervical facet resurfacing implant according to the present invention is illustrated in conjunction with a facet joint. The superior implant 102 is configured for placement on superior articular facet 30. The superior implant 102 may be fixed to the superior articulating surface 38 using cemented and/or cementless fixation techniques. In an exemplary embodiment, the superior implant 106 includes a disk-shaped

portion **106**, which has an articulating surface **110** and a fixation surface **112** and is configured for placement on a specifically prepared superior articulating surface **38**.

[0032] The disk-shaped portion **106** of the superior implant **102** may range from about 1 mm thick to about 6 mm thick. In an exemplary embodiment, the thickness of the superior implant **102** ranges from about 2 mm to about 4 mm. In another exemplary embodiment, the thickness of the superior implant **102** ranges from about 1.5 mm to about 2.5 mm. The disk-shaped portion **106** of the superior implant **102** may also range from about 3 mm in diameter to about 14 mm in diameter. In an exemplary embodiment, the diameter of the superior implant **102** ranges from about 6 mm to about 12 mm. In another exemplary embodiment, the diameter of the superior implant **102** ranges from about 8 mm to about 10 mm.

[0033] The fixation surface **112** may be generally flat or generally curved and is configured to interact with the superior articulating surface **38**. The articulating surface **110** may be generally curved and may be configured to interact with an articulating surface **118** of the inferior implant **104**.

[0034] Extending from the disk-shaped portion **106** of the superior implant is a tab **108** configured to interact with or for attachment to the lateral mass **26** of the vertebra **12**. The tab **108** may be generally curved so that it matches the natural curvature of the vertebra **12**. For example, the tab **108** and the disk-shaped portion **106** of the superior implant **102** may form an angle ranging from about 110 degrees to about 160 degrees. In one exemplary embodiment, the tab **108** and the disk-shaped portion **106** of the superior implant **102** form an angle ranging from about 120 degrees to about 150 degrees. In another exemplary embodiment, the tab **108** and the disk-shaped portion **106** of the superior implant **102** may form an angle ranging from about 130 degrees to about 145 degrees.

[0035] The tab **108** may include a hole or a slot or the like configured to receive a fixation device, such as a screw or the like. In other words, the fixation device passes through the hole or slot of the tab **108** and into the lateral mass **26** of the vertebra **12**.

[0036] The superior implant **102** may have a surface fixation mechanism for fixing the superior implant **102**, such as by fixing the fixation surface **112**, to the superior articulating surface **38**. The surface fixation mechanism may be any fixation mechanism known in the art, such as at least one of: one or more pegs, one or more pips, ridges, one or more grooves, one or more fins, and one or more screws. In an exemplary embodiment, the surface fixation mechanism includes at least one fin **122**. The fin **122** helps prevent the superior implant **102** from migrating along the superior articulating surface. In another exemplary embodiment, the surface fixation mechanism may include a plurality of ridges, grouped in regions such that the ridges in different regions are oriented in different directions. For example, the surface fixation mechanism may include four regions on the fixation surface **112** where each of the four regions has ridges oriented in a different direction. The various orientations of the ridges prevent the inferior implant **104** from moving in different directions with respect to the superior articulating surface **38**.

[0037] The fixation surface **112** of the superior implant **102** may also have a porous coating; a porous onlay mate-

rial; a biologic coating; a surface treatment, such as to facilitate bone ingrowth or cement fixation; a material facilitating bone ingrowth; and combinations thereof. For example, the fixation surface **112** may have a porous surface that is beaded, threaded, textured, etc. Further, the fixation surface **112** may have a hydroxyapatite coating or may be plasma-sprayed. In addition to the examples listed, any known method of improving fixation of biologic implants may be used to improve the interaction of the fixation surface **112** and the superior articular facet **30**.

[0038] In one exemplary embodiment, the fixation surface **112** of the superior implant **102** is configured to interact only with the superior articulating surface **38** and does not interact directly with any other aspect of the superior articular facet **30** or the facet joint **36**. The fixation surface **112** of the superior implant **102** may be generally flat or generally curved for improved interaction with the superior articulating surface **38**.

[0039] The articulating surface **110** in one exemplary embodiment is generally configured to articulate or interact with the articulating surface **118** of the inferior implant **104**. Accordingly, the articulating surface **110** of the superior implant **102** may be generally flat or generally curved. The superior implant **102** articulating surface **110** may be configured such that it acts as a "female" surface wherein it is concave or configured to accept a "male" articulating surface **118** of an inferior implant **104**. Conversely, the superior implant **102** articulating surface **110** may also be configured such that it acts as a "male" surface wherein it is convex or configured to be accepted by "female" articulating surface **118** of an inferior implant **104**.

[0040] The superior implant **102** may be composed of any material commonly used in the art for articulating medical implants. Such materials include, but are not limited to, cobalt-chromium alloys, ceramics (alumina ceramic, zirconia ceramic, yttria zirconia ceramic, etc.), titanium, ultra high molecular weight polyethylene (UHMWPE), pyrolytic carbon, titanium/aluminum/vanadium (Ti/Al/V) alloys, Tantalum, Carbon composite materials and combinations thereof. For example, the superior implant **102** may be generally composed of titanium, but have a UHMWPE articulating surface. Some materials are more appropriate for articulating surfaces and some more appropriate for fixation surfaces, but any materials known in the art for use with articulating and fixation surfaces can be used in the present invention. Such materials are commonly used in joint arthroplasty and the like.

[0041] The inferior implant **104** is configured for placement on inferior articular facet **32**. The inferior implant **104** may be fixed to the inferior articulating surface **40** using cemented and/or cementless fixation techniques. In an exemplary embodiment, the inferior implant **104** has a disk-shaped portion **114**, which has an articulating surface **118** and a fixation surface **120** and is configured for placement on a specifically prepared inferior articulating surface **40**.

[0042] The disk-shaped portion **116** of the inferior implant **104** may range from about 1 mm thick to about 6 mm thick. In an exemplary embodiment, the thickness of the inferior implant **104** ranges from about 2 mm to about 4 mm. In another exemplary embodiment, the thickness of the inferior implant **104** ranges from about 1.5 mm to about 2.5 mm. The

disk-shaped portion **114** of the inferior implant **104** may also range from about 3 mm in diameter to about 14 mm in diameter. In an exemplary embodiment, the diameter of the inferior implant **104** ranges from about 6 mm to about 12 mm. In another exemplary embodiment, the diameter of the inferior implant **104** ranges from about 8 mm to about 10 mm.

[0043] The fixation surface **120** may be generally flat or generally curved and is configured to interact with the inferior articulating surface **40**. The articulating surface **118** may be generally curved and may be configured to interact with an articulating surface **110** of the superior implant **102**.

[0044] Extending from the disk-shaped portion **114** of the inferior implant is a tab **116** configured to interact with or for attachment to the inferior articular process **28** of the vertebra **12**. The tab **116** may be generally curved so that it matches the natural curvature of the vertebra **12**. For example, the tab **116** and the disk-shaped portion **114** of the inferior implant **104** may form an angle ranging from about 10 degrees to about 70 degrees. In one exemplary embodiment, the tab **116** and the disk-shaped portion **114** of the inferior implant **104** form an angle ranging from about 20 degrees to about 60 degrees. In another exemplary embodiment, the tab **116** and the disk-shaped portion **114** of the inferior implant **104** may form an angle ranging from about 30 degrees to about 50 degrees.

[0045] The tab **116** may include a hole or a slot or the like configured to receive a fixation device, such as a screw or the like. In other words, the fixation device passes through the hole or slot of the tab **116** and into the inferior articular process **28** of the vertebra **12**.

[0046] The inferior implant **104** may have a surface fixation mechanism for fixing the inferior implant **104**, such as by fixing the fixation surface **120**, to the inferior articulating surface **40**. The surface fixation mechanism may be any fixation mechanism known in the art, such as at least one of: one or more pegs, one or more pips, ridges, one or more grooves, one or more fins, and one or more screws. In an exemplary embodiment, the surface fixation mechanism includes at least one fin, such as the fin shown as **122** on the superior implant **102**. The fin helps prevent the inferior implant **104** from migrating along the superior articulating surface. In another exemplary embodiment, the surface fixation mechanism may include a plurality of ridges, grouped in regions such that the ridges in different regions are oriented in different directions. For example, the surface fixation mechanism may include four regions on the fixation surface **120** where each of the four regions has ridges oriented in a different direction. The various orientations of the ridges prevent the inferior implant **104** from moving in different directions with respect to the inferior articulating surface **40**.

[0047] The fixation surface **120** of the inferior implant **104** may also have a porous coating; a porous onlay material; a biologic coating; a surface treatment, such as to facilitate bone ingrowth or cement fixation; and combinations thereof. For example, the fixation surface **120** may have a porous surface that is beaded, threaded, textured, etc. Further, the fixation surface **120** may have a hydroxyapatite coating or may be plasma-sprayed. In addition to the examples listed, any known method of improving fixation of biologic implants may be used to improve the interaction of the fixation surface **120** and the inferior articular facet **32**.

[0048] In one exemplary embodiment, the fixation surface **120** of the inferior implant **104** is configured to interact only with the inferior articulating surface **40** and does not interact directly with any other aspect of the inferior articular facet **32**, the inferior articular process **28**, or even the facet joint **36**. The fixation surface **120** of the inferior implant **104** may be generally flat or generally curved for improved interaction with the inferior articulating surface **40**.

[0049] The articulating surface **118** in one exemplary embodiment is generally configured to articulate or interact with the articulating surface **110** of the superior implant **102**. Accordingly, the articulating surface **118** of the inferior implant **104** may be generally flat or generally curved. The inferior implant **104** articulating surface **118** may be configured such that it acts as a "female" surface wherein it is concave or configured to accept a "male" articulating surface **110** of a superior implant **102**. Conversely, the inferior implant **104** articulating surface **118** may also be configured such that it acts as a "male" surface wherein it is convex or configured to be accepted by "female" articulating surface **110** of an superior implant **102**.

[0050] The inferior implant **104** may be composed of any material commonly used in the art for articulating medical implants. Such materials include, but are not limited to, cobalt-chromium alloys, ceramics (alumina ceramic, zirconia ceramic, yttria zirconia ceramic, etc.), titanium, ultra high molecular weight polyethylene (UHMWPE), pyrolytic carbon, titanium/aluminum/vanadium (Ti/Al/V) alloys, and combinations thereof. For example, the inferior implant **104** may be generally composed of a ceramic material or a cobalt-chromium alloy. Some materials are more appropriate for articulating surfaces and some more appropriate for fixation surfaces, but any materials known in the art for use with articulating and fixation surfaces can be used in the present invention. Such materials are commonly used in joint arthroplasty and the like.

[0051] Turning next to FIG. 7, there is provided an alternate embodiment of a cervical facet inferior implant in conjunction with a trans-lateral mass screw. In another exemplary embodiment, the inferior implant **204** is configured to interact with or attach to a trans-lateral mass fixation mechanism **202**. As shown, the trans-lateral mass fixation mechanism **202** is a screw, but may be any like fixation mechanism.

[0052] For example, the inferior implant **204** may include a threaded hole **212** either extending from or bored into the fixation surface **210** of the inferior implant **204**. The manner in which the inferior implant **204** and the trans-lateral mass fixation mechanism **202** interact may vary with different anatomies. For example, it may be preferable to offset the trans-lateral mass screw **202** from the inferior implant **204** such that when the trans-lateral mass screw **202** and inferior implant **204** interact, the trans-lateral mass screw **202** is not perpendicular to the inferior implant **204**. The trans-lateral mass screw **202** may range from about 0 degrees offset from perpendicular to about 60 degrees offset from perpendicular.

[0053] The articulating surface **208** of the inferior implant **204** is generally configured to articulate or interact with the articulating surface **110** of the superior implant **102** shown in FIG. 5. Accordingly, the articulating surface **208** of the inferior implant **204** may be generally flat or generally curved. The inferior implant **204** articulating surface **208**

may be configured such that it acts as a “male” surface wherein it is convex or configured to be accepted by a “female” articulating surface **110** of a superior implant **102**. Conversely, the inferior implant **204** articulating surface **208** may also be configured such that it acts as a “female” surface wherein it is configured to accept a “male” articulating surface **110** of a superior implant **102**.

[0054] A trans-lateral mass fixation mechanism **202** is configured to interact with the inferior implant **204**. The trans-lateral mass fixation mechanism **202** secures the inferior implant **204** to the inferior articular facet **32**. The trans-lateral mass fixation mechanism **202** may be any fixation mechanism known in the art, such as a translaminar screw. The trans-lateral mass fixation mechanism **202** may be made from any material known in the art for medical fixation devices. For example, the trans-lateral mass fixation mechanism **202** may be made from titanium, titanium/aluminum/vanadium (Ti/Al/V) alloys, Tantalum, CrCo, ceramic, carbon or carbon composite materials.

[0055] Turning next to **FIG. 8**, there is provided a flow diagram generally illustrating a method for providing articulating surfaces for facet joint articular facets. The overall flow begins at process block **802** wherein a space is created between the superior articular facet **30** and the inferior articular facet **32**. It will be understood by those skilled in the art that prior to creating the space, it may be preferable or even necessary to expose the facet joint **36** at an effected level and remove the capsule. The effected level may be exposed through use of any appropriate procedure, such as a modified “Wiltse” approach. The creation of the space at process block **602** may be accomplished by using a curette or similar device and by removing the cartilaginous surfaces of the facet joint **36**. In one exemplary embodiment, the created space is sufficient for using a rasp on an articulating surface of an articular facet. The space created between the superior articular facet **30** and the inferior articular facet **32** may range, for example, from about 2 mm to about 15 mm. In one exemplary embodiment, the space ranges from about 4 mm to about 8 mm. It should be understood that a rasp can be any tool used to scrape, grate, or file the facets.

[0056] Flow progresses to process block **804** wherein the articulating surface **40** of the inferior articular facet **32** is prepared for an inferior implant **104**. Such preparation may be made by a rasp, such as a rasp specifically designed for preparing a surface for the cervical facet implant. Progression then continues to process block **806** wherein the articulating surface **38** of the superior articular facet **30** is prepared for a superior implant **102**. Again, such preparation may be made by a rasp, such as a rasp specifically designed for preparing a surface for the cervical facet implant.

[0057] Each of the rasps of process blocks **804** and **806** may be either a single shaft rasp or a double action rasp, such as those illustrated in **FIGS. 10-12** and described in detail herein. The process of preparing the articulating surfaces **38** and **40** of the articular facets **28** and **30** may involve using multiple rasps of increasing thickness while widening the space created in process block **802**. For example, a 2 mm rasp may initially be used, then a 4 mm rasp, then a 6 mm rasp, then an 8 mm rasp, etc., until a desired result is achieved. In addition, the rasps of process blocks **804** and **806** may be the same rasp. Further, a single rasp can be used to prepare the articulating surfaces **38** and **40** concurrently.

The articulating surfaces **38** and **40** may be prepared such that a bleeding bone bed is created to facilitate bone ingrowth for the superior implant **102** and inferior implant **104**.

[0058] As shown in **FIG. 9**, when the single handed rasp is used to prepare articulating surface **38** and/or articulating surface **40**, the working end of the tool may be positioned inside the space created in process block **802**. The rasp may then be moved from an anterior to a posterior position inside the facet joint **36** in order to effect a clean and uniform resection of the created space in the shape and dimension of both implants. In other words, the articulating surface **38** is prepared such that its shape and dimension resembles the superior implant **102** and the articulating surface **40** is prepared such that its shape and dimension resembles the inferior implant **104**. The anterior/posterior movement of the rasp may be continued until the rasp is too small for the space created. The rasp may be too small when the space created is so wide that the rasp cannot prepare both the articulating surfaces **38** and **40** concurrently. A larger (thicker) rasp may then be used. Increasingly larger rasps may be used until the created space is increased such that it ranges from about 4 mm to about 8 mm. In one exemplary embodiment, the rasps are designed to cut only when moving in a posterior direction to help prevent injury during the resurfacing process.

[0059] In one embodiment, the steps of process blocks **802**, **804** and **806** are repeated on the contralateral side of facet joint **36** prior to performing the steps of process block **808**.

[0060] Progression then flows to process block **808** wherein the inferior implant **104** is placed on the prepared/resurfaced articulating surface **40** of the inferior articular facet **32**. In one exemplary embodiment, the inferior implant **104** is placed such that the disk-shaped portion **114** interacts with the articulating surface **40** of the inferior articular facet **32**, but not with other aspects of the inferior articular facet **32**.

[0061] In one alternative embodiment, a trans-lateral mass screw **202** is used to secure an inferior implant **204** to the inferior articular facet **32**. In this embodiment, the above method would also include using the trans-lateral mass screw **202** to secure the inferior implant **204** to the inferior articular facet **32**.

[0062] To facilitate placement of the trans-lateral mass screw **106**, an aiming device such as the device illustrated in **FIG. 11** may be used. The aiming device can be used to position a drill for creating a trans-lateral mass hole for the trans-lateral mass screw **202**. A drill can then be used to create the hole, which may have a diameter of about 2 mm, depending on the diameter of the trans-lateral mass screw **202**.

[0063] Once the hole is drilled, the trans-lateral mass screw **202** can be introduced into the hole and then used to secure the inferior implant **104** to the inferior articular facet **32**. In one embodiment, the steps of process blocks **808**, including any steps associated with the drilling or placement of the trans-lateral mass screw **202**, are repeated on the contralateral side of facet joint **36** prior to performing the steps of process block **810**.

[0064] Progression then continues to process block **810** wherein the superior implant **102** is placed on the prepared/

resurfaced articulating surface **38** of the superior articular facet **30**. In one exemplary embodiment, the superior implant **102** is placed such that the disk-shaped portion **106** interacts with the articulating surface **38** of the superior articular facet **30**, but not with other aspects of the superior articular facet **30**.

[0065] In one embodiment, the steps of process blocks **802**, **804**, **806**, **808** and **810** are then repeated on the contralateral side.

[0066] Turning now to **FIG. 10**, a single handed rasp is illustrated. The rasp **1000** includes a handle **1002** and a shaft **1004** connecting the handle **1002** to the working end of the rasp **1000**. Attached to the shaft **804** at the working end of the rasp **1000** is a head **1006**. The head **1006** has at least one cutting surface **1008**. In one exemplary embodiment, the cutting surface **1008** is configured to cut when the cutting surface **1008** is moved in a first direction (e.g. when the rasp is moved from the anterior to the posterior direction of the facet joint) but not when the cutting surface **1008** is moved in a direction opposite to the first direction (e.g. when the rasp is moved from the posterior to the anterior direction of the facet joint).

[0067] The rasp **1000** is configured to prepare the articulating surfaces of a facet joint. In an exemplary embodiment, the rasp **1000** is configured to prepare articulating surfaces **38** and **40** of the articular facets **28** and **30** such that the shape and dimension of the prepared articulating surfaces resembles the shape and dimension of the superior implant **102** and inferior implant **104**. For example, if the superior implant **102** and/or inferior implant **104** are curved, the head **1006** may be generally curved to properly prepare the surface for the implant.

[0068] In addition, the rasp **1000** may be made from any appropriate material commonly used for medical tools. In one exemplary embodiment, at least part of the rasp **1000** is made from titanium, although the rasp could also be made from any material known in the art.

[0069] While the present invention has been described in association with several exemplary embodiments, the described embodiments are to be considered in all respects as illustrative and not restrictive. Such other features, aspects, variations, modifications, and substitution of equivalents may be made without departing from the spirit and scope of this invention which is intended to be limited solely by the scope of the following claims. Also, it will be appreciated that features and parts illustrated in one embodiment may be used, or may be applicable, in the same or in a similar way in other embodiments.

What is claimed is:

1. A cervical facet resurfacing implant comprising:

a superior implant having an articulating surface and a fixation surface and configured for secured placement on a resurfaced superior articular facet of a selected cervical vertebra; and

an inferior implant having an articulating surface and a fixation surface and configured for secured placement on a resurfaced inferior articular facet of a cervical vertebra immediately above the selected cervical ver-

tebra such that the articulating surface of the inferior implant interacts with the articular surface of the superior implant.

2. The cervical facet resurfacing implant of claim 1 wherein the superior implant and inferior implant are each generally disk-shaped.

3. The cervical facet resurfacing implant of claim 1 wherein the superior implant further comprises a tab extending from the generally disk-shaped portion of the superior implant.

4. The cervical facet resurfacing implant of claim 3 wherein the tab is configured for attachment to the lateral mass of the selected cervical vertebra.

5. The cervical facet resurfacing implant of claim 4 wherein the tab is attached to the lateral mass of the selected cervical vertebra with a screw.

6. The cervical facet resurfacing implant of claim 3 wherein the tab and the disk-shaped portion of the superior implant form an angle of from about 110 degrees to about 160 degrees.

7. The cervical facet resurfacing implant of claim 1 wherein the inferior implant further comprises a tab extending from the generally disk-shaped portion of the inferior implant.

8. The cervical facet resurfacing implant of claim 7 wherein the tab is configured for attachment to the inferior articular process of the cervical vertebra immediately above the selected cervical vertebra.

9. The cervical facet resurfacing implant of claim 7 wherein the tab is attached to the inferior articular process of the cervical vertebra immediately above the selected cervical vertebra with a screw.

10. The cervical facet resurfacing implant of claim 7 wherein the tab and the disk-shaped portion of the inferior implant form an angle of from about 10 degrees to about 70 degrees.

11. The cervical facet resurfacing implant of claim 1 wherein at least one of the superior implant and the inferior implant comprises a surface fixation mechanism.

12. The cervical facet resurfacing implant of claim 11 wherein the surface fixation mechanism comprises at least one of: at least one peg, at least one pip, at least one fin, ridges, and at least one screw hole.

13. The cervical facet resurfacing implant of claim 12 wherein the surface fixation mechanism comprises multiple regions and wherein each of the regions has at least one ridge oriented in a different direction than the other regions.

14. The cervical facet resurfacing implant of claim 1 wherein the fixation surface of at least one of the inferior implant and the superior implant has at least one of: a porous coating, a porous onlay material, a biologic coating, a surface treatment, and a material facilitating ingrowth of bone.

15. The cervical facet resurfacing implant of claim 1 wherein the articulating surface of at least one of the inferior implant and the superior implant is composed of at least one of: cobalt-chromium alloy, ceramic, UHMWPE, pyrolytic carbon, and Ti/Al/V.

16. The cervical facet resurfacing implant of claim 1 wherein the inferior implant and superior implant each range from about 1 mm thick to about 6 mm thick.

17. The cervical facet resurfacing implant of claim 1 wherein the inferior implant and superior implant each range from about 3 mm in diameter to about 14 mm in diameter.

18. The cervical facet resurfacing implant of claim 1 further comprising a trans-lateral mass fixation mechanism for securing the inferior implant to the inferior articular facet.

19. The facet implant of claim 18 wherein the trans-lateral mass fixation mechanism comprises at least one of: a translaminal screw, a bolt and a fixation pin.

20. A facet implant comprising:

a generally disk-shaped superior implant having an articulating surface and a fixation surface and being configured for placement on a resurfaced superior articular facet of a selected cervical vertebra, the superior implant having a tab extending from the generally disk-shaped portion of the superior implant, the tab being configured for secured attachment to the lateral mass of the selected vertebra; and

a generally disk-shaped inferior implant having an articulating surface and a fixation surface and being configured for placement on a resurfaced inferior articular facet of a cervical vertebra immediately above the selected cervical vertebra such that the articulating surface of the inferior implant interacts with the articular surface of the superior implant, the inferior implant having a tab extending from the generally disk-shaped portion of the inferior implant, the tab being configured for secured attachment to the inferior articular process of the cervical vertebra immediately above the selected vertebra.

21. The cervical facet resurfacing implant of claim 20 wherein at least one of the superior implant and the inferior implant comprises a surface fixation mechanism.

22. The cervical facet resurfacing implant of claim 21 wherein the surface fixation mechanism comprises at least one of: at least one peg, at least one pip, at least one fin, ridges, and at least one screw hole.

23. The cervical facet resurfacing implant of claim 20 wherein the fixation surface of at least one of the inferior implant and the superior implant has at least one of: a porous coating, a porous onlay material, a biologic coating, a surface treatment, and a material facilitating ingrowth of bone.

24. The cervical facet resurfacing implant of claim 20 wherein the articulating surface of at least one of the inferior implant and the superior implant is composed of at least one of: cobalt-chromium alloy, ceramic, UHMWPE, pyrolytic carbon, and Ti/Al/V.

25. A method for providing articulating surfaces for vertebrae facet joint articular facets of comprising:

creating a space between a superior articular facet of a selected vertebra and an inferior articular facet of a vertebra immediately above the selected vertebra;

using a rasp to prepare an articulating surface of the inferior articular facet for an inferior implant;

using a rasp to prepare an articulating surface of the superior articular facet for a superior implant;

fixing the inferior implant on the inferior articular facet such that a fixation surface of the inferior implant interacts with the articulating surface of the inferior articular facet; and

fixing the superior implant on the superior articular facet such that a fixation surface of the superior implant interacts with the articulating surface of the superior articular facet;

wherein the articulating surface of the superior implant and the articulating surface of the inferior implant are configured to articulate with one another.

26. The method of claim 24 wherein each of the steps are repeated on articular facets on a contralateral side of the vertebrae facet joint.

27. The method of claim 24 wherein the created space is begun with a curette.

28. The method of claim 24 wherein the created space is a space sufficient for using a rasp on an articulating surface of an articular facet.

29. The method of claim 24 wherein the created space ranges from about 2 mm to about 5 mm.

30. The method of claim 24 wherein multiple rasps of increasing thickness are used to prepare the articulating surfaces of the superior and inferior articular facets.

31. The method of claim 24 wherein the articulating surfaces of the superior and inferior articular facets are prepared such that the created space is increased to accommodate the superior and inferior implants.

32. The method of claim 30 wherein the articulating surfaces of the superior and inferior articular facets are prepared such that the shape and dimension of superior articular facet resembles the superior implant and the shape and dimension of the inferior articular facet resembles the inferior implant.

33. The method of claim 30 wherein the created space is increased such that it ranges from about 4 mm to about 15 mm.

34. The method of claim 24 wherein the articulating surfaces of the superior and inferior articular facets are prepared such that a bleeding bone bed is created to facilitate bone ingrowth.

35. The method of claim 24 wherein the inferior and superior articulating surfaces are prepared by the same rasp.

36. The method of claim 24 wherein at least one rasp is configured to cut when moving in a first direction, but not when moving in a direction opposite of the first direction.

37. The method of claim 24 further comprising securing the inferior implant to the inferior articular facet with a trans-lateral mass fixation mechanism.

* * * * *