

Dec. 22, 1970

J. S. HOCHHEISER

3,549,990

NON-SPARKING A-C CONNECTORS

Filed Aug. 19, 1968

3 Sheets-Sheet 1

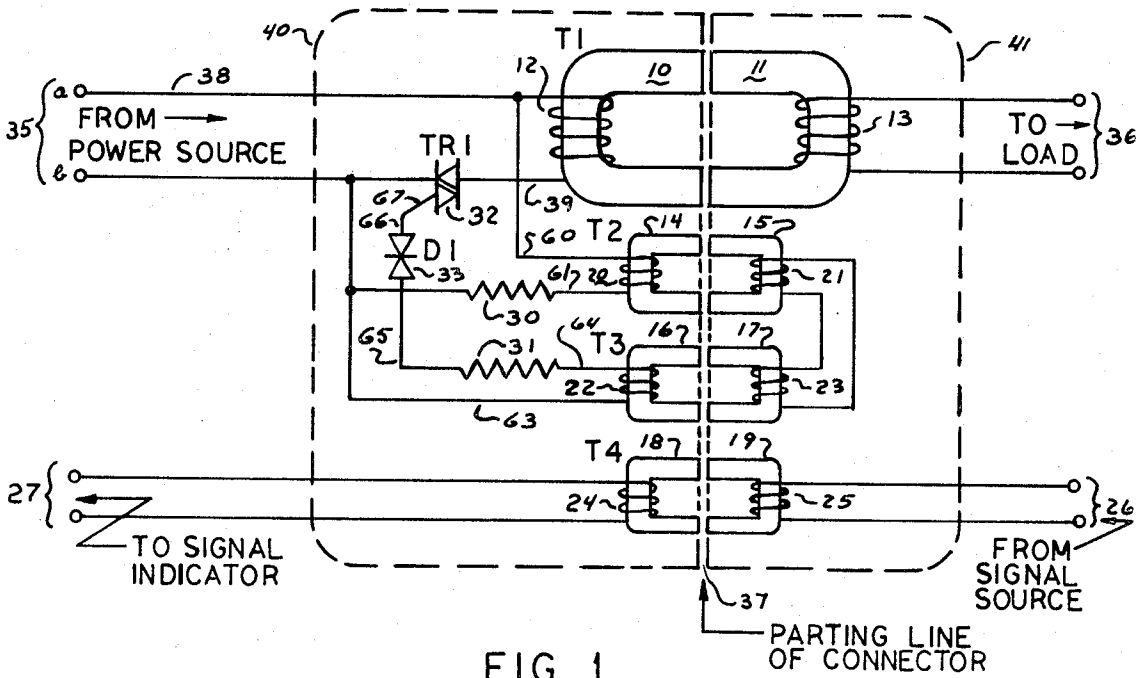

FIG. 1

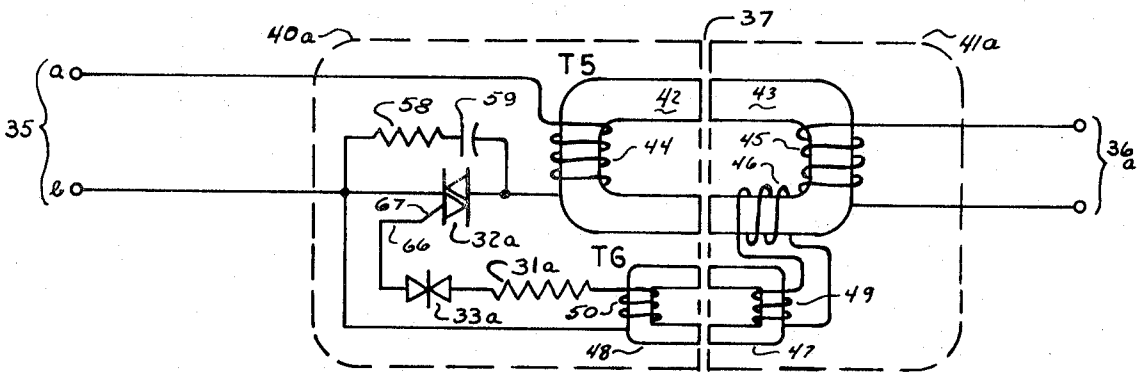

FIG. 2

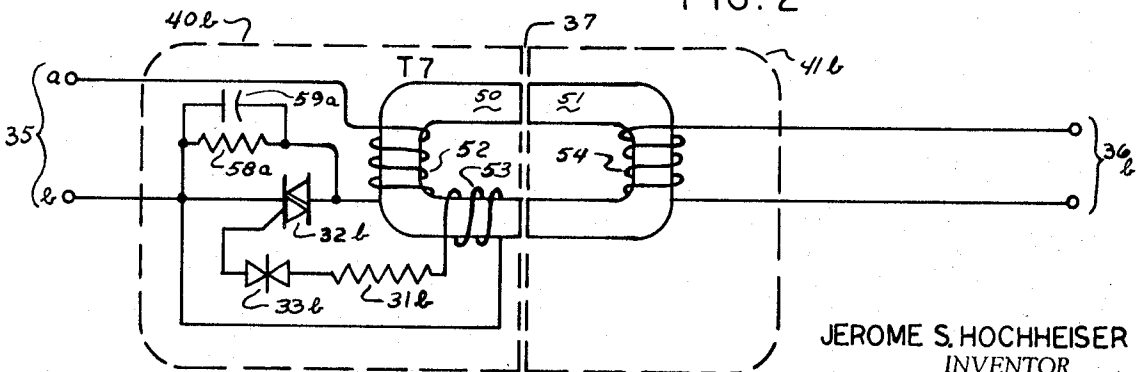

FIG. 3

JEROME S. HOCHHEISER
INVENTOR.

BY *Norman L. Chaff*

AGENT

Dec. 22, 1970

J. S. HOCHHEISER

3,549,990

NON-SPARKING A-C CONNECTORS

Filed Aug. 19, 1968

3 Sheets-Sheet 2

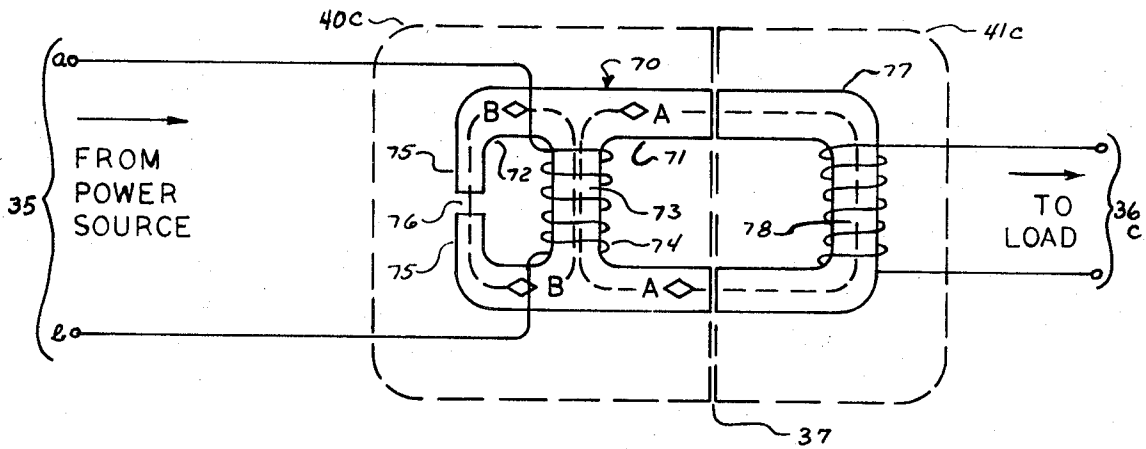

FIG. 4

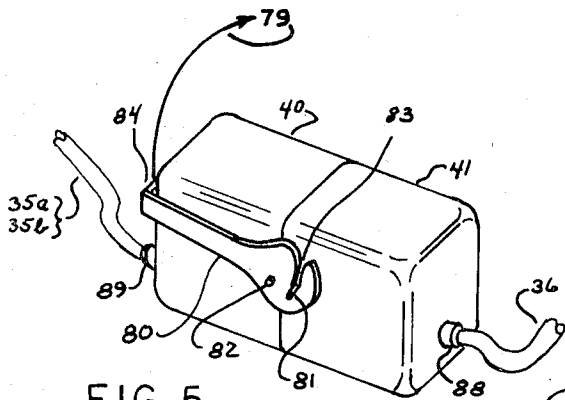

FIG. 5

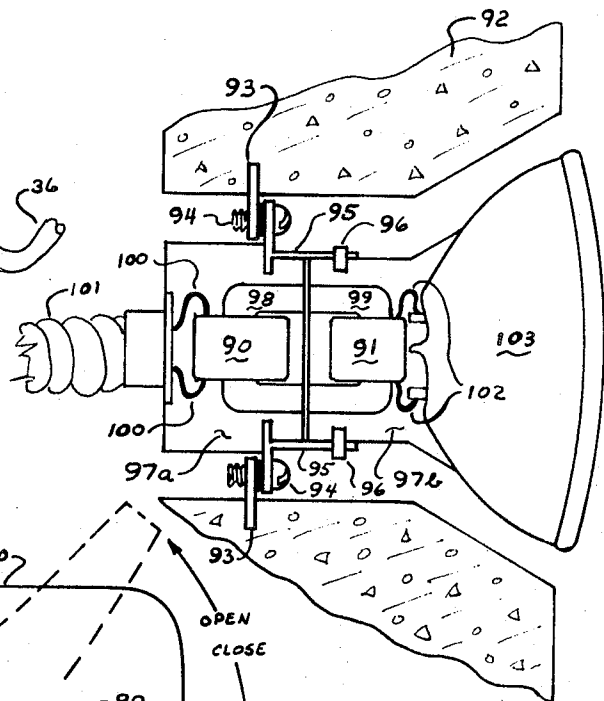

FIG. 7

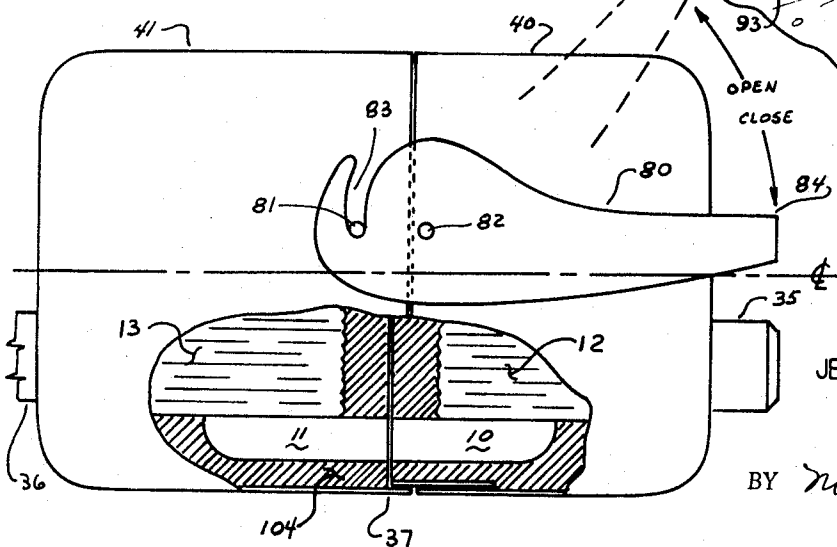

FIG. 6

JEROME S. HOCHHEISER
INVENTOR.

BY *Norman L. Chalpin*

AGENT

Dec. 22, 1970

J. S. HOCHHEISER

3,549,990

NON-SPARKING A-C CONNECTORS

Filed Aug. 19, 1968

3 Sheets-Sheet 3

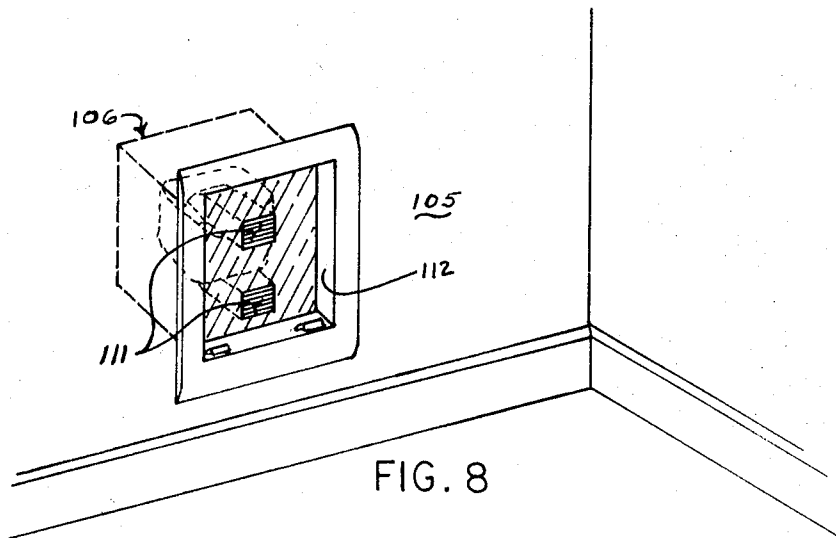

FIG. 8

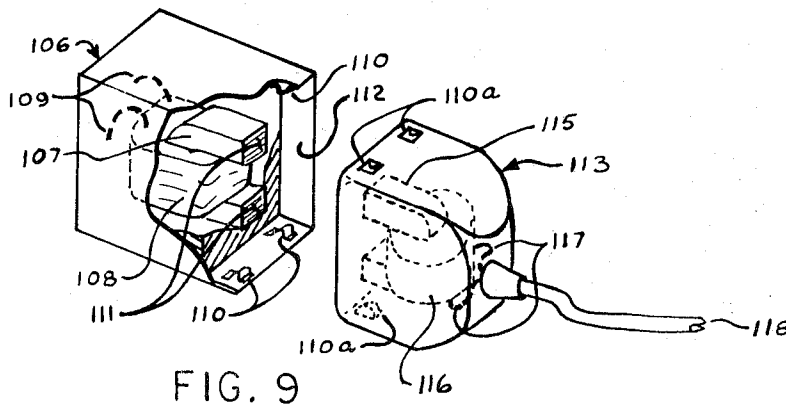

FIG. 9

JEROME S. HOCHHEISER
INVENTOR.

BY *Norman L. Chalf.*

AGENT

1

3,549,990
NON-SPARKING A-C CONNECTORS
Jerome S. Hochheiser, 8847 Oakdale Ave.,
Northridge, Calif. 91324
Filed Aug. 19, 1968, Ser. No. 753,645
Int. Cl. H02m 5/12

U.S. Cl. 323-44

11 Claims

ABSTRACT OF THE DISCLOSURE

Electric non-sparking connection devices in any environment are disclosed. A-C or signal connections can be made with these connectors so that the signals or power may be transferred from a source to a load without direct wire connection which otherwise would spark on contact or on disconnect. The connection devices include a receptacle and plug, each with a respective half core on which a winding is wound. The half cores are separable and mate together. On the core of the receptacle is a primary winding. The primary is connected to a source of power or signals. The plug unit core has at least a secondary winding which is connected to a load. When the cores are brought together in mating relation by inserting the plug in the receptacle energy from the source is transferred to the load via the electromagnetic coupling through the now completed core.

BACKGROUND OF THE INVENTION

At the present state of the art of A.C. electrical power distribution in domestic and industrial usage one brings wires from an electrical power generator to an area where this power is to be used. Usually the power is transmitted on these wires at high voltage. Transformers at various steps in the process step the voltage up or down until the potential at relatively low voltage is delivered to individual sockets in homes and industrial or other structures into which the utilization devices (loads) are ultimately "plugged in."

When it becomes necessary to deliver A.C. electric power to devices in certain hazardous, wet, or gaseous environments as in a hospital where oxygen or other potentially explosive gases may be exposed to sparks, or in a swimming pool where a short or leakage to ground represents a lethal hazard to swimmers, or in a submarine environment where the disconnection might lead to short circuiting of the exposed terminals, presently highly complex and costly leakage sensors and circuit breakers are used to attempt to avoid the dangers by detecting the leak and opening the circuits.

Interconnections for moisture-proof operation in a submarine environment are now made in especially constructed plug and socket assemblies within bellows with hermetic seals. These are generally awkward to use and still must be sealed by a secondary closure after separation to avoid moisture entering the receptacles or reaching the contacts. Other sealed connectors use rubber casings to isolate the plugs which must be separated within the casings.

There is no absolutely safe electric power delivering plug and socket arrangement available today for use in hazardous environments such as set forth above. Similarly there is no really safe electrical wall connection that does not provide a shock hazard to inquisitive children with

2

bits of wire or metallic prod-like objects—nor is there a safe swimming pool light or other power connector.

THE PRESENT INVENTION

Utilizing the basic principle of the transformer the present invention provides an utterly safe method to transfer A.C. electric power or signals from a source to a load for domestic, industrial, military or marine applications.

If one considers a conventional electric power transformer, it is constructed of a primary and secondary winding on a core. The core in some transformers is in the form of an E with an I closing the open ends of the E.

Other transformers employ a toroidal core or a core in the form of a flattened oval. In any event primary and secondary windings are normally wound on these cores and in the usual course of the use of such transformers energy is transferred from the primary to the secondary.

If a toroidal core or one in the flattened oval form is split to form two identical C shaped forms with a primary winding on one and a secondary winding on the other and if the primary winding is connected to an A.C. source, bringing the secondary C core back into an exact mating relationship with the primary C core will result in the transfer of A.C. energy from the primary to the secondary. Removing the secondary C core from the primary C core and the load device connected to the secondary no longer receives power.

In a practical embodiment the secondary side of the electrical coupling device according to the invention may include a tertiary winding which couples back to the primary side via another core or onto the same core for applying a control or triggering signal to a semi conductor switching device such as a silicon controlled rectifier or similar device to apply the primary current to the device only when the two halves of the cores are mated together.

Practical embodiments also include snap together receptacle and plug elements which when interfitted provide the core mating connection for the one or more cores included in the assembly.

Several embodiments of the invention are set forth in the specification and illustrated in the drawings. These embodiments should not be construed as limiting the invention to the specific forms thereof shown or described since those skilled in the arts appertaining to the invention will be able to devise other embodiments in view of the teachings herein within the ambit of the claims which follow the specification.

IN THE DRAWINGS

FIG. 1 is schematic representation of a split core magnetic signal and power transfer coupling element according to the invention showing the use of several cores for power, signal and control applications;

FIG. 2 is another schematic circuit diagram illustration of another embodiment of the invention employing multiple windings and multiple cores;

FIG. 3 is a schematic circuit diagram of a further embodiment of the invention incorporating multifunction use of a single core;

FIG. 4 is a schematic circuit diagram of still another embodiment of the invention incorporating a figure-8 shaped core with extra gap for regulator action;

3

FIG. 5 is a typical assembled plug and receptacle assembly as used in a submarine or other environmental application of the invention;

FIG. 6 is a partially cutaway view of the device shown in FIG. 5 to show the internal construction thereof;

FIG. 7 illustrates in a partially cutaway form the installation of a connection device according to this invention for installation in swimming pools;

FIG. 8 is an illustration of how the invention may be applied to structures for household or industrial electrical power outlets; and

FIG. 9 is a partially cutaway drawing of the outlet of FIG. 8 showing how a cord and plug arrangement according to the invention can be connected.

DESCRIPTION OF THE INVENTION

The basic form of the invention can be seen to be connector assemblies in two halves 40, 41 which are shown in FIGS. 1-4 in schematic form and in FIGS. 5 and 6 as completed assemblies.

Referring to FIG. 1 the left connector half 40 of the schematic circuit arrangement can be seen to include the C or halves of cores 10, 14, 16, 18 and the right connector half 41 includes the opposite C or halves of cores 11, 15, 17, 19. When the assemblies 40-41 are mated together core halves 10-11, 14-15, 16-17, and 18-19 butt up against one another, the ends thereof meeting exactly in register on the parting line 37 of the connector halves 40, 41.

On matching core halves 10-11 primary winding 12 (on C-half 10) and secondary winding 13 (on C-half 11) form a transformer T-1. Winding 12 is connected by one lead to one side of an A.C. power line 35a. The other lead 39 of primary 12 is connected through a Triac (a trade name for a bi-directional semi conductor triggered switch) identified as TR1 to the other side of power line 35b. The secondary winding 13 connects to a load circuit at 36.

Similarly on core halves 14-15 primary winding 20 and secondary winding 21 are wound to form a transformer identified as T-2. Windings 22 and 23 on core halves 16-17 form transformer T-3. Windings 24 and 25 on core halves 18-19 form transformer T-4.

For the simplest explanation of the principle on which the invention rests consider only the transformer T-4 within the connector halves 40-41 in FIG. 1. If there were an alternating current signal from a signal source applied via leads at 36 to winding 25, as long as core halves 18-19 are butting together there will be a transfer of the energy to winding 24 and out via leads 27 to some utilization device which may be a signal indicator lamp or the like. If the two connector halves are separated thus separating the core halves 18 and 19 (along with the other cores in the assembly) the transformer is broken and there will be no transfer of energy to winding 24 from the source feeding winding 25.

Now examine windings 12 and 13 on transformer T-1 (cores 10-11). Any energy (A.C. power) applied on leads 38-39 from source 35a-35b to winding 12 is transferred by transformer action to winding 13 and thus to a load at leads 36 so long as core halves 10-11 are in contact with one another, mating and matching. Similarly, separating the connector halves 40-41 will result in the termination of the transformer action and no signal or power is transferred to winding 13 so that no energy will be applied to a load device connected to leads 36.

Special attention should be given to the two transformers T-2 and T-3 formed with cores 14-15 and 16-17. Note that winding 21 on T-2 (the secondary) is coupled by direct electrical connection within connector half 41 to winding 23 on T-3. The primary of T-2 (winding 20) is connected to the source of A.C. power leads 35a, 35b with a series current limiting resistor 30 in the return lead 61 terminating in the return line 35b of the power source.

4

The primary of transformer T-3 (winding 23) receives the signal or power from the source at 35a-35b via the path including leads 60 and 61 and through resistor 30, primary winding 20 of T-2 and secondary winding 21 of T-2. The signal on primary winding 23 of T-3 is coupled to its secondary winding 22 through core halves 16 and 17. Secondary winding 22 has one lead 63 connected to the input or cathode lead of Triac 32 which is also the return or common line 35b of the power source, and its other lead 64 connected through current limiting resistor 31 to one side 65 of a Diac 33 (a trade name for a bi-directional semi-conductor diode D1). The other side 66 of diode 33 is connected to the triggered electrode 67 of the Triac 32.

The operation of connector assembly 40-41 illustrated in FIG. 1 may now be described as follows. The transformer T-1 (windings 12 and 13) is the power transfer transformer. The windings 12 and 13 have a turns ratio for either step-up or step-down in voltage to winding 13 as may be desired to operate the load device or devices to be connected to secondary 13 at leads 36. The ratio also be a 1:1 ratio.

The transfer of energy from winding 12 to winding 13 on core 10-11 will be affected by two conditions. One is the proximity of core halves 10-11 to one another; the most efficient transfer being when they are in exact mating and butting relationship. The second element affecting the operation of the transformer T-1 is the action of Triac 32 under the control of Diac 33. When an appropriate very small amplitude of D.C. signal is applied to gate or trigger electrode 67 of Triac 32 the Triac becomes conductive completing the circuit from A.C. power source at 35a-35b to the primary winding 12 of transformer T-1. This action is well known and described in any number of texts, for example the General Electric Company's Handbooks on Semi-Conductor Devices published since 1967 and in the Hobbyists Handbooks published by the Radio Corporation of America.

The small D.C. signal is generated by rectifier action of the Diac 33 upon the A.C. signal applied to Diac 33 via winding 22 through the path detailed above. The turns ratio of windings from winding 20 to 21 and 23 to 22 is step down so as to produce the small triggering voltage necessary to actuate Triac 32 into conductivity.

Separating the connector halves 40-41 will not only open the magnetic A.C. coupling path between windings on T-1 but also will open the magnetic coupling path of transformers T-2, T-3 and T-4. This removes the triggering signal from Triac gate 67 and renders Triac 32 non-conducting and therefore in effect open-circuiting primary 12 of transformer T-1. Thus, when the connector halves 40-41 are parted no power is applied to primary winding 12 even though not in fact disconnected from the power line.

The Diac-Triac arrangement described above prevents any loading of the power line 35a-35b when no devices are connected to the connector system of this invention. The Diac-Triac arrangement also makes an on/off switch unnecessary since merely disconnecting the secondary connector half 41 from primary half 40 accomplishes complete removal of power from the system components.

Any signal or power may be transferred via windings of T-4 which may go in either direction with source and load interchanged at will. Without a Diac-Triac switch as described above circuits such as T-4 will include high enough impedance in the external circuits to preclude excessive loading when the cores are separated and the magnetic flux path broken.

In FIG. 2 the two connector halves 40a-41a include only two pairs of C-core halves 42-43 and 47-48. Primary 44 and secondary 45 on cores 42-43 forming transformer T-5 act in the same manner as primary and secondary 12-13 described in FIG. 1. The tertiary winding 46 on core 43 is connected to the primary 49 of the second transformer T-6 in the connectors 40a-41a which in

5

turn couples via cores 47-48 to secondary 50. Winding 50 drives Diac 33a.

The operation of transformer T-6 in FIG. 2 is the same as that of transformer T-3 in FIG. 1, to provide the necessary triggering signal with Diac 33a and Triac 32a to perform the switching action already described in FIG. 1. The resistor and capacitor 58, 59 are a corrective impedance network to apply an initial starting signal to primary 44 so that there is enough energy transferred to tertiary winding 46 to operate transformer T-6 and permit it to provide the turn on signal via Diac 33a to Triac 32a. The resistor-capacitor combination 58-59 may be in parallel for particular applications as in FIG. 3 at 58a-59a or there may be only a capacitor, or only a resistor depending on characteristics of the particular components which are employed.

Similarly to that described in FIG. 1 when the two halves 40a-41a of the connector system are separated the circuit load device connected at 36a will derive no power from the source at 35a-b and Triac 33a will become non-conductive, protecting primary winding 44.

FIG. 3 is a further variation in the circuit arrangement by which the triggering on and shut-off of power by a Diac/Triac arrangement (here 32b/33b) is accomplished. In the two connector halves 40b-41b only a single transformer T-7 and hence only one pair of split core halves 50-51 are used. The primary winding 52 on core half 50 and another winding 53 also on core 50 provide the transformer by which the signal for Diac/Triac 32b/33b triggering is accomplished.

When the core halves 50-51 are butting together in mating relationship a complete transformer T-7 is formed so that there will be energy transfer from primary 52 to secondary 54 when primary 52 is energized. Also there will be transfer of energy from winding 52 to winding 53.

Just as above described for transformer T-5/T-6 the impedance devices 58a-59a permit sufficient starting signal to be applied to the transformer primary 52 of T-7 so that the triggering action of the Diac/Triac can be effected.

In FIG. 4 a further example of an A.C. energy transfer device is shown employing the same principles of split magnetic core coupling hereinbefore described.

The difference in FIG. 4 is that the halves of the connector 40c and 41c do not encase identical pairs of cores as in the previously described examples. The left half core 70 has a C section 71 and an O section 72. The O section 72 and C section 71 share a common upright 73 on which primary winding 74 is wound. The O portion of the core 78 opposite the common upright 73 has a gap 76 shown at the center, but which may be anywhere convenient in the magnetic loop B-B except in the upright 73 common with loop A-A.

This gap 76 has a special function in making the transformer-connector shown in FIG. 4 behave as a regulating transformer.

In the second half 41c of the connector the C core 77 mates with C portion of core 70 in the primary half 40c.

Secondary winding 78 is placed on core 77 in the manner similar to that of the other secondary cores.

The flux path illustrated by dashed lines A-A is the path for power transfer of energy from primary winding 74 to secondary winding 78. The flux path B-B is in fact a leakage flux. Therefore the air gap at 76 is made relatively large compared to the parting line gap 37 so that under normal transformer action the transformer is reasonably efficient. When the halves are parted the flux path B-B through air gap 76 is a reluctance path of such low level that the resulting inductance of the primary winding 74 will prevent excessive loading of the power source. In this manner the requirement of the Diac/Triac switch as used in previously described examples is eliminated.

6

In FIG. 5 a perspective view of a typical assembly of connectors 40-41 according to this invention is shown.

With reference to the circuit schematic shown in FIG. 1 and the partially cutaway side view of the assembly of FIG. 5 which is shown in FIG. 6 the parts of the assembly may be more readily appreciated.

The water-tight or sealed assembly halves 40-41 are held together by a latching clamp 80, 81, 82, 83, 84 which includes a saddle bar 80/84 pivoting on an axis 82. The view of the article does not show both sides but the side not seen looks the same (except for the handedness of the posts) as does the side shown in FIG. 5.

There is a slot 83 in the latching clamp countoured so as to receive a pin 81. The saddle bar when moved in the direction of arrow 79 by pulling on the cross link section 84 thereof rotates on pivot 82 in connector half shell housing 40. The crescent or sickle contoured slot 83 in saddle bar 80/84 engages pin 81 in the other connector half shell housing 41 to pull the two halves 40-41 tightly together. The action in the direction of arrow 79 disengages contoured slot 83 from pins 81 applying a force against the tendency of magnetic attraction of the cores permitting the halves 40-41 to be separated easily. When pulled up tight the cores 10-11 (see FIG. 6) are pulled tightly together providing the coupling between windings 12 and 13 to give the transformer action, electro-magnetically coupling the energy from primary 12 to secondary 13 as hereinbefore more fully described. The leads 35/36 from primary and secondary windings exit from their respective half shells 40/41 via sealing outlets 88/89 by techniques well-known in this art. The cores and windings in each half shell are encapsulated with a non-hydroscopic plastic as indicated at 104 in FIG. 6. By so doing both connector halves can be exposed to electrically conductive or corrosive liquids without danger of short circuits.

From the foregoing description of FIGS. 1 through 6 it should be clear that the new device and technique of this invention provide an improved way to provide power to loads without a direct physical wire connection. It also provides a safer power outlet and power connection arrangement which can be used in underwater or otherwise hazardous environments. The transfer of the energy from source to load is accomplished by a transformer action with primary and secondary wound on respective matching halves of the transformer core. The advantages of this technique apart from the safety due to the absence of sparking when connecting or disconnecting the load from the source are, that from a source, for example of 110 volts on a primary and secondary side may be wired so that either 1:1 or higher or lower ratios may be achieved in the transformer action thereby operating higher voltage apparatus or lower voltage apparatus from a common outlet. The reason this is possible is because the connector on the load device is part of the load device and the turns used in the winding on its half-core element (such as say the device shown in FIG. 3 including 51, winding 54 and the connector shell 41b) will be such as to provide the appropriate voltage to its utilization element to be connected (in the device of FIG. 3) to lines 36b.

The system may be applied to the transfer of a plurality of signals either related to one another as in the transformers T-1, T-2 and T-3 of FIG. 1, or independent signals as would be the case of using transformer T-4 in the same connector encasement 40-41 as shown in FIG. 1.

In the case of the interrelated windings used in the outlet plug and connector arrangements for those devices shown in FIGS. 1, 2 and 3, they may be on separate cores of core pairs as shown in FIG. 1, or there may be several windings 45, 46 on the secondary core as in FIG. 2, or there may be several windings 52, 53 on the primary core as in FIG. 3.

The windings on primary and secondary cores may separate upon separation of the half cores so as to terminate the transfer of power from primary to secondary by the

mere spatial separation of the windings as would be the case of the arrangement shown in FIG. 1 for cores 18-19 and windings 24-25 of transformer T-4. To achieve a more positive termination of the power so that not even the condition of an unloaded or open secondary or the absence of a secondary with the primary still connected to the power source may be present, there are shown circuits for switching power on and off to the primary winding via double acting diode and double acting thyristor switches such as the Diac/Triac combinations shown in FIGS. 1-3 with a variety of circuits for triggering the thyristor switches as shown in FIGS. 1-3.

In FIGS. 5 and 6 separable plug and receptacle halves are shown for use of the invention on cables which might be for underwater or hazardous environment applications. The housings or encasements 40-41 in FIG. 5 are shown to be held together by a saddle strap clamp 80-84 but other means could be used to clamp the two halves together.

As an example of an application of the invention where electrical currents can be an extreme hazard and the use of the invention makes the operation and use safe, consider the swimming pool lamp installation illustrated in FIG. 7.

In the wall of a swimming pool 92 a receptacle area 97a is provided, with mounting hardware plates 93 embedded therein. To the hardware plates 93 are assembled slide receptacles 95 by screws 94. Within the area 97a a primary half-core 98 is embedded with a primary winding 90 wound thereon connected by wires 100 to a source of 110 volt or similar A.C. power brought to the swimming pool wall receptacle area via waterproof and armored cable 101 of the approved subterranean type. A lamp assembly including a lamp 103, a secondary half-core 99, matching core 98 with a secondary winding 91 wound thereon and connected by wires 102 to lamp 103 is assembled to the slide bars 95 on straps 96 which interfit over bars 95 to bring the secondary core 99 into mating and butting alignment with primary core 98. Thus, when power is applied to the input leads 100 energizing the transformer formed by primary 90, secondary 91 and cores 98-99 the lamp will be lit. To remove a lamp for replacement involves a simple pulling action to slide the lamp element off of guide bars 95 and put a new lamp in its place.

Since water entering into the receptacle after the lamp and its assembly is removed does not complete the magnetic circuit necessary to fulfill the requirement of transformer action no sparks or no electric current will be in contact with the water. Thus a present hazard in swimming pool lighting is eliminated by using the principles of this invention. Although the illustration of FIG. 6 shows the transformer cores 98-99 and windings 90-91 as single elements they may also be such as those shown in FIGS. 1 through 4 to achieve switching and regulating action.

In FIGS. 8 and 9 a household or industrial wall socket installation of the system of this invention is illustrated. In a wall 105 of room a receptacle box 106 of conventional configuration can contain the primary portion of a connection system according to this invention incorporating a half-core 107 and primary winding 108 with leads 109 connected to an A.C. source of power. The open ends 111 of core 107 are the only exposed portions of the system and these carry no electric potential so that there is no danger of shock in inquisitive infant fingers should they come in contact with the core ends 111.

The receptacle plug 113 inserts into the flange or recess area 112 of receptacle box 106. In receptacle box 106 at the flange or recessed area 112 are springs 110 entering the recess. Four springs 110 are shown, but more or fewer may be used as needed. In the end of plug 113 recesses 110a are provided to mate with springs 110 so that when plug 113 is inserted into recess 112 the springs 110 snap into and engage recesses 110a and hold plug 113 in place to mate with core 107.

Within plug 113 is a secondary half-core 115 with a secondary winding 116 thereon. Leads 117 connect secondary 116 to a cable 118 which is connected to a load device not shown but which may be any appliance or instrument or lighting fixture or other utilization element that may be desired.

Switching of the power to the plug receptacle such as 106/113 with its transformer arrangement according to this invention can be accomplished by conventional wall switches or by means of the techniques set forth in FIGS. 1-3. In the latter case receptacle 106 and plug assembly 113 will include multiple winding and/or multiple core arrangements shown in FIGS. 1-3.

There has been disclosed hereinabove an entirely new approach to the distribution of A.C. electric signal generally and A.C. electric power particularly. The new method can be described as including the steps of applying an alternating current to a winding such as 12 on a half-core such as 10 in FIG. 1 and bringing a matching half-core such as 11 into mating and abutting proximity with the first named half-core 10, the second half-core 11 having thereon a winding such as 13 thereby providing a magnetic coupling path via the cores 10, 11 for the inductive coupling of the alternating current applied to winding 12 to the winding 13 and applying the alternating current induced in winding 13 to a load device, for example like the swimming pool lamp shown in FIG. 7.

The new approach can be implemented as described hereinabove by wall socket assemblies as shown in FIGS. 8 and 9, underwater connections as shown in FIG. 7 and in other environments where it is important to preclude sparking when making and breaking circuit connections.

Examples of such environments are in hospitals in the use of anaesthetic gases and certain volatile fluids; in industrial plants where possible explosive fumes are likely to be present.

The new technique of magnetic coupling configurations to transfer A.C. power to loads as hereinabove described permits connection and disconnection of the load device plugs from the source outlets without sparking.

When the source outlet is "open" that is, has no load device plug in it, it may be in any environment, even underwater, without "shorting" which would be characteristic of all prior art male-female plug and socket connection techniques.

Coming in contact with the exposed core ends such as 111 (FIG. 8) presents no danger of shock or electrical short. The most disturbing effect could be a buzzing noise if a metal object came in contact with these core ends.

What is claimed as new is:

1. A non-sparking alternating electrical current connection means comprising:

a first housing having an open end and having wires brought thereinto from an external source of alternating current electric power;

at least a first magnetic half-core disposed in said first housing having a first winding thereon electrically connected to said wires, the open ends of said first magnetic half-core facing outwardly from said open end of said first housing, the open end forming a recess in said housing to receive a mating plug;

a second housing having an open end and having wires exiting therefrom for connection to an external load device;

at least a second magnetic half-core disposed in said second housing having a second winding thereon electrically connected to said exiting wires, the open ends of said second magnetic half-core facing outwardly from said open end of said second housing, said open ends of said second core being aligned with said open ends of said second housing, and in a matching and mating relationship to said open ends of said first magnetic half-core; and

said second housing having an external dimension so as

9

to interfit with said first housing in said recess in said first housing to bring said open ends of said second half-core into abutting and mating relationship with said first half-core to form a completed core, whereby alternating electric power from said external source is inductively transferred via said first winding to said second winding by the electro-magnetic inductive path formed by the completion of said core to apply said alternating electric current to said external load device.

2. The non-sparking alternating electrical current connection means defined in claim 1 wherein said second winding has a step-down turns ratio with respect to said first winding to reduce the voltage applied to said load with respect to the voltage of said external source of alternating electric power.

3. The non-sparking alternating electrical current connection means defined in claim 1 wherein said first housing is in a wall box outlet configuration and installed in the wall of a structure.

4. The non-sparking alternating electrical current connection means defined in claim 1 wherein said first housing is in a wall box outlet configuration and installed in the wall of a swimming pool.

5. The non-sparking alternating current connection means defined in claim 1 wherein said second winding has a step-up ratio with respect to said first winding to raise the voltage applied to said load with respect to the voltage of said external source of alternating electric power.

6. The non-sparking alternating current connection means defined in claim 1 wherein said recess in said first housing has springs entering said recess and said second housing has recessed receptacles for said springs, so that when said second housing is inserted into said first housing said springs engage said recessed receptacles to hold said first housing and said second housing together.

7. In the non-sparking alternating electrical current connection means defined in claim 1

a semi-conductor switch connected in between one of said wires in said first housing and said first winding and a winding in addition to said first winding on said first core, said winding-in-addition being connected to said semi-conduction switch and said semi-conductor switch being responsive to currents developed in said winding-in-addition to become conductive when said second housing is brought into said first housing and second core mated with said first core,

and to remain non-conductive when said housings and said cores are separated, thereby acting as a power on-off switch for said non-sparking connection means.

8. A non-sparking alternating electrical current connection means comprising:

a first housing having an open end and having wires brought thereinto from an external source of alternating current electric power;

a plurality of first magnetic half-cores disposed in said first housing, each having an individual winding respectively thereon, at least one of said individual windings being connected to said wires, the open ends of each of said first magnetic half-cores facing outwardly from said open end of said first housing, the open end of said housing forming a recess therein to receive a mating plug;

a second housing having an open end and having at least a pair of wires exiting therefrom for connection to an external load device;

a plurality of second magnetic half-cores corresponding in number to those in said first housing disposed in said second housing each of said plurality of second cores having a second winding thereon, at least one of said second windings electrically connected to said pair of exiting wires, the open ends of said second magnetic half-core facing outwardly from said open

10

end of said second housing, said open ends being aligned with said open end of said second housing, and in a matching and mating relationship to said open ends of said first magnetic half-cores; and said second housing having an external dimension such as to interfit with said first housing in said recess in said first housing to bring said open ends of said second half-cores into abutting and mating relationship with said first half-cores to form a plurality of completed cores,

whereby alternating electric signals or currents applied to each said windings on said first plurality of half-cores are inductively transferred via said windings to the corresponding windings on said plurality of second half-cores by the electro-magnetic inductive path formed by the completion of said cores to apply said alternating electric current to external load devices which may be connected to the windings on said second cores.

9. The connection means defined in claim 8 wherein said at least one of said windings has a semi-conductor switching device in said wire lead, said semi-conductor switching device including a triggering element connected to a bi-directional rectifier device and said bi-directional rectifier device being connected to one of said plurality of windings on one of said first cores, another of said plurality of windings on another of said plurality of first cores being connected to said wires in said first housing connected to said external source of A.C. electric power, the corresponding second core winding to said winding on said first core connected to said bi-directional rectifier and the corresponding second core winding to said first core winding connected to said wires in said first housing being connected together whereby when said housings are brought together A.C. electric current from said external source in said wires in said first housing is coupled via said second cores with said second windings connected together to said bi-directional rectifier to trigger said semi-conductor switch to turn on power to said external load devices.

10. A safe electrical connector comprising:

a first housing including one-half of a transformer with C-shaped core ends exposed in said housing to the outside of said housing;

a second housing matable with said first housing and having the second half of said transformer with the matching C-shaped core ends to said first housing core ends exposed to the outside of said housing,

A.C. electric current connections from an external source connected to said one-half of said transformer; and

load wires connected between said second half of said transformer and an external load device;

said exposed ends of said cores ends in said housing being butted together so that the A.C. electric current is electromagnetically coupled from said external source to said external load device via the transformer formed by bringing said one-half and said other half together.

11. A signal and power connection device comprising: a first housing having therein a plurality of C-shaped cores;

a second housing having a matching plurality of C-shaped cores;

one of the cores in said first housing and the matching core in said second housing having a primary and secondary winding respectively for transferring power between a source of power and a load;

another core in said first housing and the matching core in said second housing having a primary and secondary winding respectively connected between a source of signals and a utilization circuit for said signals;

the remaining cores in said first and second housings having respective interconnected primary and secondary windings coupled to the source and to semi-

11

conductor control devices for regulating the flow of current in said primary and secondary windings of said power transfer connection, such that upon the disconnection of said connection device by separation of said matching cores, power to said primary winding of said one of said cores in said first housing is removed.

References Cited

UNITED STATES PATENTS

2,967,267 1/1961 Steinman et al. ----- 317-99X
 3,146,051 8/1964 Woofter et al. ----- 339-91X

12

3,192,499 6/1965 West ----- 339-91
 3,292,579 12/1966 Buchanan ----- 336-221X
 3,418,552 12/1968 Holmes ----- 320-2

5 J D MILLER, Primary Examiner
 G. GOLDBERG, Assistant Examiner

U.S. Cl. X.R.

10 317-11, 101; 323-51; 339-91