

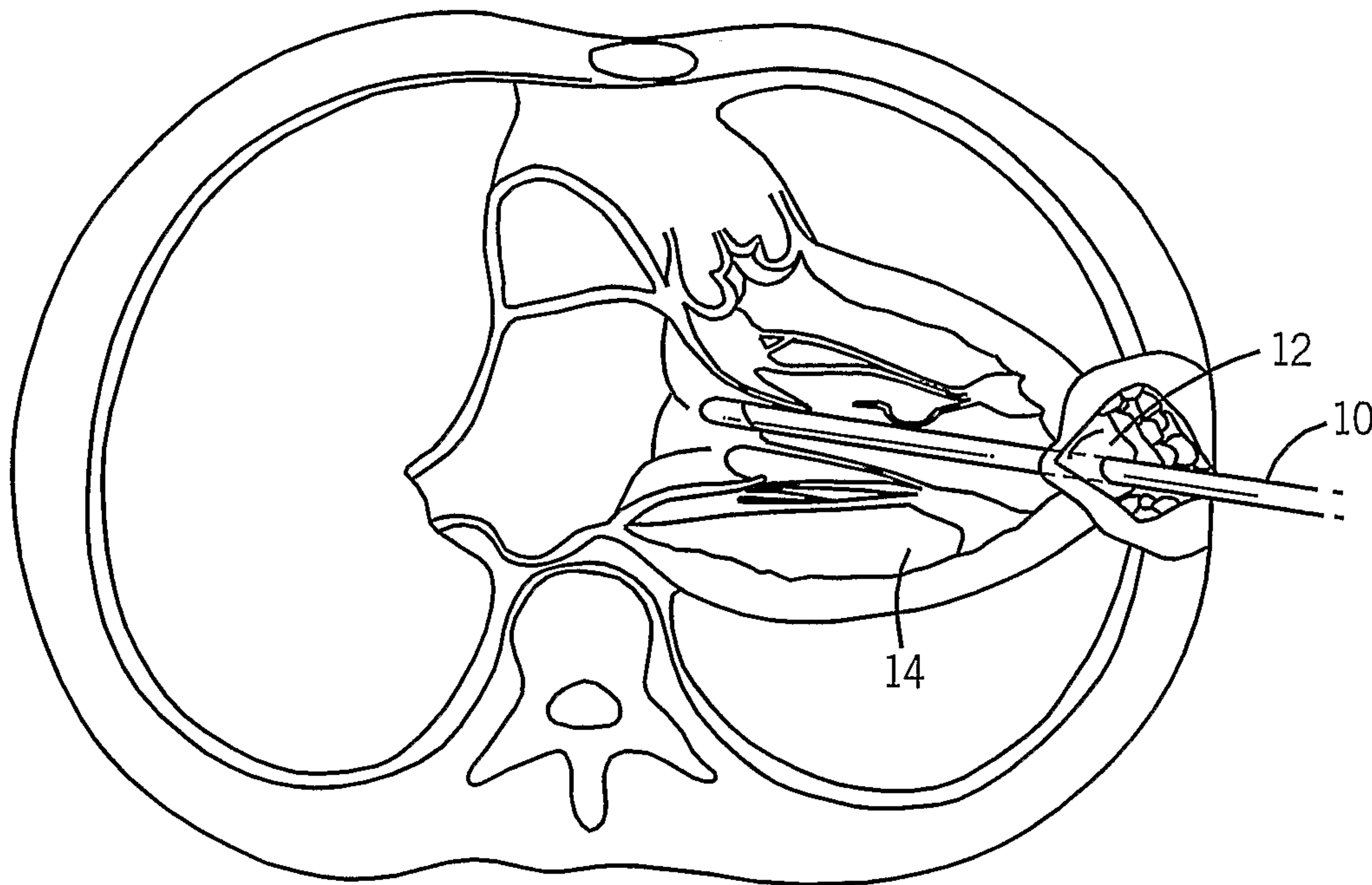

(86) Date de dépôt PCT/PCT Filing Date: 2006/01/19
 (87) Date publication PCT/PCT Publication Date: 2006/07/27
 (85) Entrée phase nationale/National Entry: 2007/07/20
 (86) N° demande PCT/PCT Application No.: US 2006/001699
 (87) N° publication PCT/PCT Publication No.: 2006/078694
 (30) Priorité/Priority: 2005/01/21 (US60/645,677)

(51) Cl.Int./Int.Cl. *A61F 2/24* (2006.01),
A61B 17/062 (2006.01)
 (71) Demandeur/Applicant:
MAYO FOUNDATION FOR MEDICAL EDUCATION AND
RESEARCH, US
 (72) Inventeur/Inventor:
SPEZIALI, GIOVANNI, US
 (74) Agent: GOUDREAU GAGE DUBUC

(54) Titre : METHODE ET APPAREIL DE REPARATION THORASCOPIQUE DE LA VALVULE CARDIAQUE
 (54) Title: THORASCOPIC HEART VALVE REPAIR METHOD AND APPARATUS



(57) **Abrégé/Abstract:**

An instrument for performing thorascopic repair of heart valves includes a shaft for extending through the chest cavity and into a heart chamber providing access to a valve needing repair. A movable tip on the shaft is operable to capture a valve leaflet and a needle is operable to penetrate a capture valve leaflet and draw the suture therethrough. The suture is thus fastened to the valve leaflet and the instrument is withdrawn from the heart chamber transporting the suture outside the heart chamber. The suture is anchored to the heart wall with proper tension as determined by observing valve operation with an ultrasonic imaging system.

(12) INTERNATIONAL APPLICATION PUBLISHED UNDER THE PATENT COOPERATION TREATY (PCT)

(19) World Intellectual Property Organization
International Bureau(43) International Publication Date
27 July 2006 (27.07.2006)

PCT

(10) International Publication Number
WO 2006/078694 A2

(51) International Patent Classification: Not classified

(21) International Application Number:
PCT/US2006/001699

(22) International Filing Date: 19 January 2006 (19.01.2006)

(25) Filing Language: English

(26) Publication Language: English

(30) Priority Data:
60/645,677 21 January 2005 (21.01.2005) US(71) Applicant (for all designated States except US): **MAYO FOUNDATION FOR MEDICAL EDUCATION AND RESEARCH** [US/US]; 200 First Street SE, Rochester, MN 55905 (US).

(72) Inventor; and

(75) Inventor/Applicant (for US only): **SPEZIALI, Giovanni** [US/US]; 130 Cheval Lane NE, Rochester, MN 55906 (US).(74) Agent: **SAMMONS, Barry, E.; QUARLES & BRADY LLP**, 411 East Wisconsin Avenue, Milwaukee, WI 53202 (US).

(81) Designated States (unless otherwise indicated, for every kind of national protection available): AE, AG, AL, AM, AT, AU, AZ, BA, BB, BG, BR, BW, BY, BZ, CA, CH, CN, CO, CR, CU, CZ, DE, DK, DM, DZ, EC, EE, EG, ES, FI, GB, GD, GE, GH, GM, HR, HU, ID, IL, IN, IS, JP, KE, KG, KM, KN, KP, KR, KZ, LC, LK, LR, LS, LT, LU, LV, LY, MA, MD, MG, MK, MN, MW, MX, MZ, NA, NG, NI, NO, NZ, OM, PG, PH, PL, PT, RO, RU, SC, SD, SE, SG, SK, SL, SM, SY, TJ, TM, TN, TR, TT, TZ, UA, UG, US, UZ, VC, VN, YU, ZA, ZM, ZW.

(84) Designated States (unless otherwise indicated, for every kind of regional protection available): ARIPO (BW, GH, GM, KE, LS, MW, MZ, NA, SD, SL, SZ, TZ, UG, ZM, ZW), Eurasian (AM, AZ, BY, KG, KZ, MD, RU, TJ, TM), European (AT, BE, BG, CH, CY, CZ, DE, DK, EE, ES, FI, FR, GB, GR, HU, IE, IS, IT, LT, LU, LV, MC, NL, PL, PT, RO, SE, SI, SK, TR), OAPI (BF, BJ, CF, CG, CI, CM, GA, GN, GQ, GW, ML, MR, NE, SN, TD, TG).

Published:

— without international search report and to be republished upon receipt of that report

For two-letter codes and other abbreviations, refer to the "Guidance Notes on Codes and Abbreviations" appearing at the beginning of each regular issue of the PCT Gazette.

(54) Title: THORASCOPIC HEART VALVE REPAIR METHOD AND APPARATUS

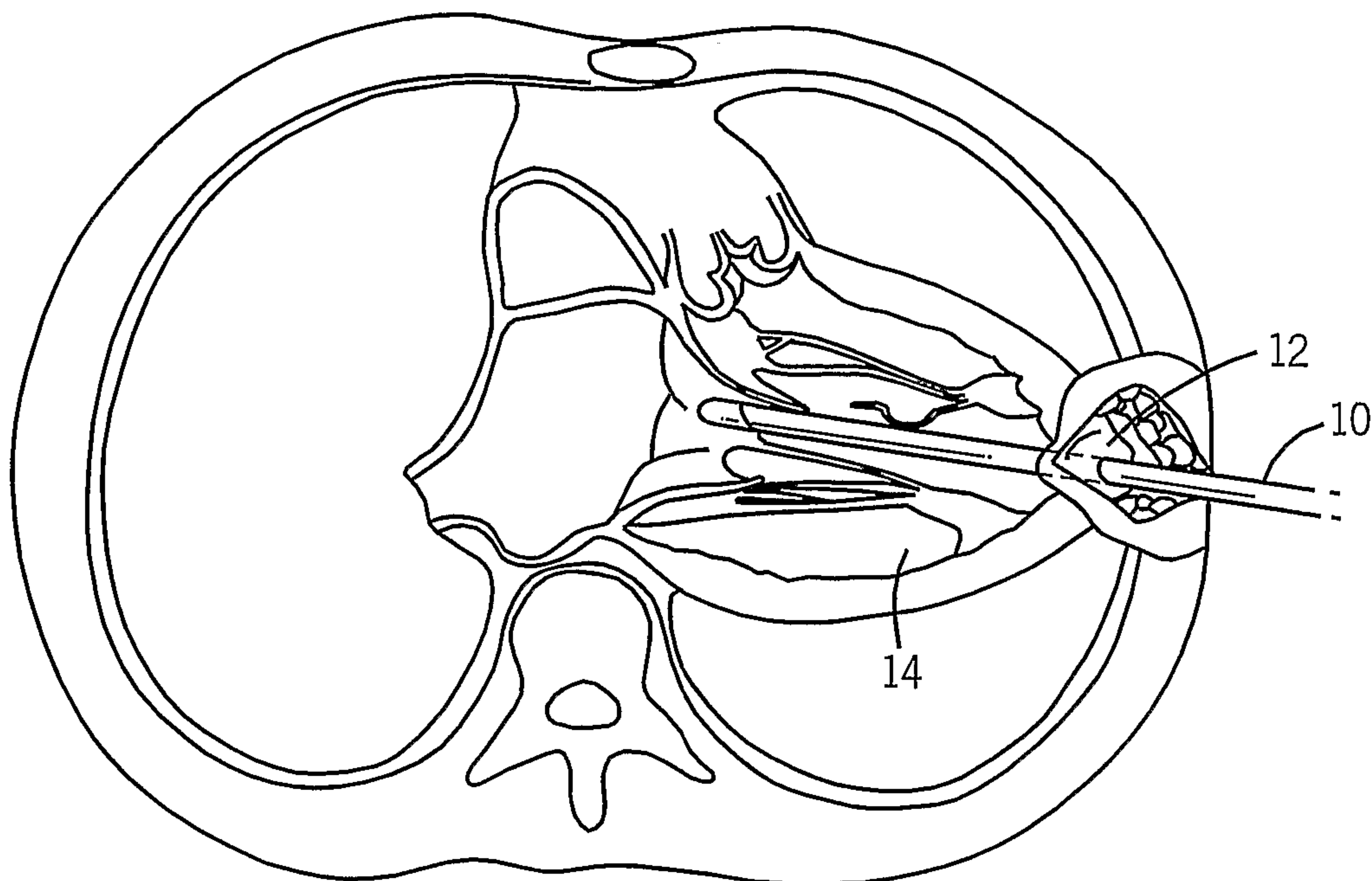

(57) Abstract: An instrument for performing thoroscopic repair of heart valves includes a shaft for extending through the chest cavity and into a heart chamber providing access to a valve needing repair. A movable tip on the shaft is operable to capture a valve leaflet and a needle is operable to penetrate a captured valve leaflet and draw the suture therethrough. The suture is thus fastened to the valve leaflet and the instrument is withdrawn from the heart chamber transporting the suture outside the heart chamber. The suture is anchored to the heart wall with proper tension as determined by observing valve operation with an ultrasonic imaging system.

WO 2006/078694 A2

THORASCOPIC HEART VALVE REPAIR METHOD AND APPARATUS

CROSS-REFERENCE TO RELATED APPLICATIONS

[0001] This application is based on U.S. Provisional Patent Application Serial No. 60/645,677 filed on January 21, 2005 and entitled "THORASCOPIC HEART VALVE REPAIR METHOD AND APPARATUS."

BACKGROUND OF THE INVENTION

[0002] Various types of surgical procedures are currently performed to investigate, diagnose, and treat diseases of the heart and the great vessels of the thorax. Such procedures include repair and replacement of mitral, aortic, and other heart valves, repair of atrial and ventricular septal defects, pulmonary thrombectomy, treatment of aneurysms, electrophysiological mapping and ablation of the myocardium, and other procedures in which interventional devices are introduced into the interior of the heart or a great vessel.

[0003] Using current techniques, many of these procedures require a gross thoracotomy, usually in the form of a median sternotomy, to gain access into the patient's thoracic cavity. A saw or other cutting instrument is used to cut the sternum longitudinally, allowing two opposing halves of the anterior or ventral portion of the rib cage to be spread apart. A large opening into the thoracic cavity is thus created, through which the surgical team may directly visualize and operate upon the heart and other thoracic contents.

[0004] Surgical intervention within the heart generally requires isolation of the heart and coronary blood vessels from the remainder of the arterial system, and arrest of cardiac function. Usually, the heart is isolated from the arterial system by introducing an external aortic cross-clamp through a sternotomy and applying it to the aorta between the brachiocephalic artery and the coronary ostia. Cardioplegic fluid is then injected into the coronary arteries, either directly into the coronary ostia or through a puncture in the aortic root, so as to arrest cardiac function. In some cases, cardioplegic fluid is injected into the coronary sinus for retrograde perfusion of the myocardium. The patient is placed on cardiopulmonary bypass to maintain peripheral circulation of oxygenated blood.

[0005] Of particular interest to the present invention are intracardiac procedures for surgical treatment of heart valves, especially the mitral and aortic valves. According to recent estimates, more than 79,000 patients are diagnosed with aortic and mitral valve disease in U.S. hospitals each year. More than 49,000 mitral valve or aortic valve replacement procedures are performed annually in the U.S., along with a significant number of heart valve repair procedures.

[0006] Various surgical techniques may be used to repair a diseased or damaged valve, including annuloplasty (contracting the valve annulus), quadrangular resection (narrowing the valve leaflets), commissurotomy (cutting the valve commissures to separate the valve leaflets), shortening mitral or tricuspid valve chordae tendonae, reattachment of severed mitral or tricuspid valve chordae tendonae or papillary muscle tissue, and decalcification of valve and annulus tissue. Alternatively, the valve may be replaced, by excising the valve leaflets of the natural valve, and securing a replacement valve in the valve position, usually by suturing the replacement valve to the natural valve annulus. Various types of replacement valves are in current use, including mechanical and biological prostheses, homografts, and allografts, as described in Bodnar and Frater, *Replacement Cardiac Valves* 1-357 (1991), which is incorporated herein by reference. A comprehensive discussion of heart valve diseases and the surgical treatment thereof is found in Kirklin and Barratt-Boyes, *Cardiac Surgery* 323-459 (1986), the complete disclosure of which is incorporated herein by reference.

[0007] The mitral valve, located between the left atrium and left ventricle of the heart, is most easily reached through the wall of the left atrium, which normally resides on the posterior side of the heart, opposite the side of the heart that is exposed by a median sternotomy. Therefore, to access the mitral valve via a sternotomy, the heart is rotated to bring the left atrium into a position accessible through the sternotomy. An opening, or atriotomy, is then made in the left atrium, anterior to the right pulmonary veins. The atriotomy is retracted by means of sutures or a retraction device, exposing the mitral valve directly posterior to the atriotomy. One of the fore mentioned techniques may then be used to repair or replace the valve.

[0008] An alternative technique for mitral valve access may be used when a median sternotomy and/or rotational manipulation of the heart are undesirable. In this technique, a large incision is made in the right lateral side of the chest, usually in the region of the fifth intercostal space. One or more ribs may be removed from the patient, and other ribs near the incision are retracted outward to create a large opening into the thoracic cavity. The left atrium is then exposed on the posterior side of the heart, and an atriotomy is formed in the wall of the left atrium, through which the mitral valve may be accessed for repair or replacement.

[0009] Using such open-chest techniques, the large opening provided by a median sternotomy or right thoracotomy enables the surgeon to see the mitral valve directly through the left atriotomy, and to position his or her hands within the thoracic cavity in close proximity to the exterior of the heart for manipulation of surgical instruments, removal of excised tissue, and/or introduction of a replacement valve through the atriotomy for attachment within the heart. However, these invasive, open-chest procedures produce a high degree of trauma, a significant risk of complications, an extended hospital stay, and a painful recovery period for the patient. Moreover, while heart valve surgery produces beneficial results for many patients, numerous others who might benefit from such surgery are unable or unwilling to undergo the trauma and risks of current techniques.

[0010] The mitral and tricuspid valves inside the human heart include an orifice (annulus), two (for the mitral) or three (for the tricuspid) leaflets and a subvalvular apparatus. The subvalvular apparatus includes multiple chordae tendinae, which connect the mobile valve leaflets to muscular structures (papillary muscles) inside the ventricles. Rupture or elongation of the chordae tendinae result in partial or generalized leaflet prolapse, which causes mitral (or tricuspid) valve regurgitation. A commonly used technique to surgically correct mitral valve regurgitation is the implantation of artificial chordae (usually 4-0 or 5-0 Gore-Tex sutures) between the prolapsing segment of the valve and the papillary muscle. This operation is generally carried out through a median sternotomy and requires cardiopulmonary bypass with aortic cross-clamp and cardioplegic arrest of the heart.

SUMMARY OF THE INVENTION

[0011] The present invention is a method and apparatus for performing a minimally invasive thoracoscopic repair of heart valves while the heart is beating. More specifically the method includes inserting an instrument through the subject's chest wall and through the heart wall. The instrument carries on its distal end a movable element which is manipulated to grasp a valve leaflet and hold it while a needle mechanism punctures the valve leaflet and loops a suture around a portion of the valve leaflet. The instrument is withdrawn from the heart along with the suture and the suture is tied off at the apex of the heart after adjusting its tension for optimal valve operation as observed with an ultrasonic imaging system.

[0012] In addition to grasping and needle mechanisms, the instrument includes fiber optics which provide direct visual indication that the valve leaflet is properly grasped. A set of illuminating fibers terminate at the distal end of the instrument around the needle mechanism in close proximity to a set of sensor fibers. The sensor fibers convey light from the distal end of the instrument to produce an image for the operator. When a valve leaflet is properly grasped, light from the illuminating fibers is reflected off the leaflet surface back through the sensor fibers. On the other hand, if the valve leaflet is not properly grasped the sensor fibers see blood.

[0013] A general object of the invention is to provide an instrument and procedure which enables heart valves to be repaired without the need for open heart surgery. The instrument is inserted through an opening in the chest wall and into a heart chamber while the heart is beating. The instrument enables repair of a heart valve, after which it is withdrawn from the heart and the chest.

DETAILED DESCRIPTION OF THE PREFERRED EMBODIMENT

[0014] Under general anesthesia and double-lumen ventilation, the patient is prepped and draped so as to allow ample surgical access to the right lateral, anterior and left lateral chest wall (from the posterior axillary line on one side to the posterior axillary line on the other side). As shown in Fig. 1, one or more thoracoscopic ports are inserted in the left chest through the intercostal spaces and an instrument 10 is inserted through one of these ports into the chest cavity. Alternatively, a small (3-5 cm) left thoracotomy is performed in the fifth or sixth intercostals space on the anterior axillary line. The patient is fully heparinized. After collapsing the left lung,

the pericardium overlying the apex 12 of the left ventricle 14 is opened and its edges are suspended to the skin incision line. This provides close access to the apex of the heart. Guidance of the intracardiac procedure is provided by a combination of transesophageal or intravascular echocardiography (not shown in the drawings) and with direct visualization through a fiber-optical system built into the instrument 10 as will be described in detail below. A double-pledgeted purse-string suture is placed on the apex of the left ventricle 12 and a stab incision is made at that location. The surgical instrument 10 is inserted through this incision, into the left ventricular chamber 14 of the beating heart.

[0015] Referring particularly to Fig. 2, the instrument 10 may be used to grasp a prolapsing segment of the mitral valve 16 and an artificial chorda 18 may be secured to its free edge. Accurate positioning of the implanted artificial chorda 18 is guaranteed by both echo and direct fiberoptic visualization as will be described in detail below. The instrument 10 is then withdrawn from the left ventricle chamber 14 pulling the unattached end of the neo-implanted chorda 18 with it. Hemostasis is achieved by tying the purse-string suture around the incision in the left ventricular apex 12 after the instrument 10 and chorda 18 are withdrawn. As shown in Fig. 3, the neo-implanted chorda 18 is appropriately tensioned under direct echo-Doppler visualization and secured outside the apex 12 of the heart. That is, a tension is placed on the neo-implanted chorda 18 and the operation of the repaired valve 16 is observed on the ultrasound image. The tension is adjusted until regurgitation is minimized.

[0016] While a single chorda 18 is implanted in the above description, additional chorda, or sutures, can be implanted and attached to the apex 12 of the heart wall with optimal tension. In this case the tensions in all the neo-implanted chorda 18 are adjusted until optimal valve operation is achieved.

[0017] As shown in Figs. 4 and 5, the instrument 10 used to perform the above procedure includes a rigid metal shaft 100 having a handle 120 at its extrathoracic (proximal) end which enables the instrument to be manipulated and guided into position. Actuating mechanisms for controlling the grasping mechanism and needle mechanism located at the distal end 140 of the instrument are also mounted near the handle 120. As will be described below, the grasping mechanism

is operated by squeezing the scissor-grip handle 120, and the needle mechanism is operated by moving an up-turned control shaft 122.

[0018] Located on the distal, intracardiac end 140 of the instrument 10 is a grasping mechanism which can be operated to hold a prolapsing valve leaflet. As shown in Figs. 6 and 7, in the preferred embodiment this mechanism is a tip 160 which is supported on the distal end of the shaft 100 by a set of rods 162. The rods 162 slide within the shaft 100 to move the tip 160 between an open position as shown in Figs. 6B and 7 and a closed position as shown in Fig. 6A when the scissor-grip handle 120 is operated. As will be explained below, a mitral valve leaflet is located in the gap between the open tip 160 and the distal end of shaft 100 and it is captured by closing the tip 160 to pinch the valve leaflet therebetween.

[0019] Disposed in a needle lumen 164 formed in the shaft 100 is a needle 180 which connects to the control shaft 122 at the proximal end of shaft 100. Needle mechanism 180 slides between a retracted position in which it is housed in the lumen 164 near the distal end of the shaft 100 and an extended position in which it extends into the sliding tip 160 when the tip is in its closed position. As a result, if a valve leaflet has been captured between the tip 160 and the distal end of shaft 100 the needle may be extended from the lumen 164 by moving control shaft 122 to puncture the captured leaflet and pass completely through it.

[0020] The distal end of the shaft 100 also contains an artificial chorda, or suture 18 that is to be deployed in the patient's heart. The suture 18 is typically a 4-0 or 5-0 suture manufactured by a company such as Gore-Tex. This suture 18 is deployed by the operation of the grasping mechanism and the needle mechanism 180 as described in more detail below.

[0021] The shaft 100 has a size and shape suitable to be inserted into the patient's chest and through the left ventricle cardiac wall and form a water-tight seal with the heart muscle. It has a circular or ellipsoidal cross-section and it houses the control links between the handle end and the intracardiac end of the instrument as well as a fiber optic visualization system described in more detail below.

[0022] As shown in Figs. 8A-8F, the preferred embodiment of the suture deployment system at the distal end of the instrument 10 is positioned around a valve leaflet 16 to be repaired as shown in Fig. 8A. The suture 18 is folded at the

middle to form a loop 19 that is positioned in the tip 160. Both ends of the suture 18 are disposed in a suture lumen 165 formed in the shaft 100 beneath the rods 162. As shown in Fig. 8B, the valve leaflet 16 is grasped by closing the tip 160, and the needle 180 is extended to puncture the leaflet 16 and extend into the tip 160. A notch 166 formed on one side of the needle 180 hooks the suture loop 19. The needle 180 is then retracted back through the leaflet 16 to pull the suture loop 19 through the puncture opening as shown in Fig. 8C. The leaflet 16 is then released and the instrument 10 is withdrawn from the heart as shown in Fig. 8D pulling both ends and the midpoint of the suture 18 with it. As shown in Fig. 8E, the suture 18 is released by the instrument 10 and the surgeon inserts the two suture ends 21 through the loop 19 at its midpoint. The ends 21 are then pulled and the loop 19 slides along the suture 18 back into the heart chamber 14 where it forms a Larks head around the edge of the valve leaflet as shown in Fig. 8F.

[0023] Multiple sutures 18 may be implanted in this manner until a satisfactory result is obtained. After deployment of the sutures 18, the heart wall incision is repaired by either a pre-positioned purse-string suture or by any kind of appropriate hemostatic device or technique. Hemostasis is checked, appropriate chest drainage tubes are positioned and secured, and all incisions are closed.

[0024] As shown in Figs. 9A-9D, a second embodiment of the suture deployment system at the distal end of the instrument 10 is positioned around a valve leaflet 16 to be repaired as shown in Fig. 9A. The suture 18 in this embodiment is a closed loop with one end of the loop disposed in the tip 160 and its other end disposed in the lumen 164 and wrapped around the needle 180. The needle 180 is extended through the grasped valve leaflet 16 into the instrument tip 160 where it hooks one end of the looped suture 18 in a notch 166 formed on one side of the needle as shown in Fig. 9B. The needle 180 is then retracted to pull the the looped suture 18 through the puncture opening in the leaflet 16. The leaflet is then released as shown in Fig. 9C by sliding the tip 160 to its open position. The instrument 10 is then withdrawn as shown in Fig. 9D to slide the unhooked end of the looped suture 18 along the length of the needle toward the leaflet 16 where it forms a Larks head around the leaflet edge.

[0025] The instrument 10 is then withdrawing from the heart chamber 14 pulling the hooked end of the suture 18 through the heart wall. The suture 18 is secured to the outside of the heart apex.

[0026] As shown in Figs. 10A-10D, a third embodiment of the suture deployment system at the distal end of the instrument 10 is positioned around a valve leaflet 16 to be repaired as shown in Fig. 10A. The midpoint 17 of the suture 18 is looped around the lumen 164 and its two loose ends 20 are coiled up in the tip 160. After the tip 160 is closed to capture the valve leaflet 16, the needle 180 is extended through the grasped valve leaflet 16 into the instrument tip 160. The free ends 20 of the suture 18 are positioned in the tip 160 to form a loop 19 and a notch 166 formed on one side of the needle extends through this loop 19 and "hooks" the free ends of the suture 18 as shown in Fig. 10B. The needle 180 is then retracted back into the lumen 164 to pull the hooked ends of the suture 18 through the puncture opening in the leaflet 16. The leaflet is then released as shown in Fig. 10C by sliding the tip 160 to its open position. The instrument 10 is then withdrawn from the heart as shown in Fig. 10D to pull the free ends 20 back through the valve leaflet 16 and a Larks head is formed around the leaflet edge by the midpoint 17 of the suture 18.

[0027] The instrument 10 is then withdrawn from the heart chamber 14 pulling the free ends 20 of the suture 18 through the heart wall. The free ends 20 of the suture 18 are secured to the outside of the heart apex.

[0028] Other suture deployment systems are possible where, for example, the needle may penetrate through the leaflet and link up with a snap fitting device that is attached to one end of the looped suture 18 in the instrument tip 160. The needle then withdraws pulling the device and looped suture back through the penetration opening in the leaflet as described above.

[0029] As shown in Fig. 7 to enhance visibility during this procedure, four fiberoptic channels 170 extend along the length of the instrument shaft 100 and terminate at its distal end. Each channel 170 contains at least one illuminating fiber which connects at its extrathoracic end to a white light source (not shown in the drawings). Each channel 170 also contains at least one sensor fiber which conveys reflected light from the distal end back to a visualization monitor (not shown in the

drawings) connected to its extrathoracic end. In the preferred embodiment each channel 170 includes two illuminating fibers and two sensor fibers.

[0030] The four fiberoptic channels 170 are disposed around the needle lumen 164 such that when a valve leaflet 16 is properly grasped, the valve leaflet tissue 16 rests against the distal end of all the fibers 170. As a result, light is reflected off the tissue back into the sensor fibers and four white circles are displayed on the visualization monitor. When the leaflet 16 is not properly pressed against the distal end of a channel 170, light is not reflected from the leaflet 16 and the visualization monitor displays the red color reflected from blood. When no valve tissue is captured, the monitor shows four red dots and when valve tissue is captured, the dots corresponding to the fiberoptic channels 170 contacting the tissue turn white. If the monitor shows all four dots as white, it means that the valve tissue capture is optimal. If only the upper two dots turn white and the bottom dots remain red, the "bite" on the valve leaflet 16 is too shallow for a proper attachment of the suture 18.

[0031] In addition to the fiberoptic visualization system that insures that a valve leaflet is properly captured, other real-time visualization systems are employed to help guide the instrument 10 to the valve leaflet 16. Preferably a transesophageal or intravascular color-Doppler echocardiography system is used for this purpose. As explained above, this imaging system is also used to determine the length of the neo-implanted artificial chordae in real-time by observing reduction or disappearance of regurgitation by transesophageal or intravascular color-Doppler echocardiography.

CLAIMS

1. A method for repairing a heart valve, the steps comprising:
 - a) inserting an instrument through the subject's chest wall and into the chest cavity;
 - b) inserting the distal end of the instrument through a heart wall and entering a heart chamber;
 - c) grasping a leaflet on the heart valve with a movable device on the distal end of the instrument;
 - d) puncturing the leaflet with a needle disposed on the distal end of the instrument and drawing a suture through the puncture to connect the suture thereto;
 - e) anchoring the suture to another structure in the heart;
 - f) withdrawing the instrument from the heart chamber; and
 - g) withdrawing the instrument from the chest cavity.
2. The method as recited in claim 1 in which step e) includes withdrawing the suture with the instrument from the heart chamber as recited in step f) and anchoring the suture to the outer surface of the heart wall.
3. The method as recited in claim 2 in which the tension on the suture is adjusted before anchoring by observing the operation of the heart valve using a medical imaging system.
4. The method as recited in claim 1 which includes placing a purse-string suture in the heart wall around the location of the instrument insertion.
5. The method as recited in claim 1 in which the distal end of the instrument is inserted in step b) through the apex of the heart.
6. The method as recited in claim 5 in which step e) includes withdrawing the suture with the instrument from the heart chamber as recited in step f) and anchoring the suture to the outer surface of the heart wall near the apex of the heart.

7. An instrument for repairing a heart valve the combination comprising:
a shaft for insertion through a chest wall and into a heart chamber;
a movable element mounted on the distal end of the shaft and being operable from the extrathoracic end of the shaft to capture and hold a valve leaflet against the distal end of the shaft;
a suture disposed in the distal end of the instrument; and
a needle mechanism mounted on the distal end of the shaft and being operable from the extrathoracic end of the shaft to penetrate through a captured valve leaflet and draw a suture back through the penetration.

8. The instrument as recited in claim 7 which includes:
an illumination fiberoptic that extends through the shaft and terminates at the distal end of the shaft; and
a sensor fiberoptic that extends through the shaft and terminates at the distal end of the shaft;
wherein the distal ends of the fiberoptics are positioned such that light is conveyed to the valve leaflet when the valve leaflet is captured and reflected back through the sensor fiberoptic.

9. The instrument as recited in claim 8 in which there are a plurality of illumination and sensor fiberoptics with their distal ends disposed around the needle mechanism.

10. The instrument as recited in claim 7 in which the movable element is a tip which is slidably mounted to the distal end of the shaft and slidable from an open position in which a space is created between the tip and the distal end of the shaft and a closed position in which the space is substantially reduced to grasp a valve leaflet therebetween.

11. The instrument as recited in claim 10 in which the needle mechanism is operable to extend outward from the distal end of the shaft, through a captured valve leaflet and into the tip.

12. The instrument as recited in claim 11 in which the suture is disposed in the tip and the needle mechanism includes means for attaching to the suture when extended into the tip.

13. The instrument as recited in claim 12 in which the means for attaching is a notch formed along one side of a needle that penetrates through the valve leaflet, the notch being positioned when the needle mechanism is extended into the tip to hook the suture.

14. The instrument as recited in claim 11 in which the suture is disposed in the shaft with a loop formed at its midpoint extending into the tip.

15. The instrument as recited in claim 14 in which the means for attaching is a notch formed along one side of a needle that penetrates through the valve leaflet, the notch being positioned when the needle mechanism is extended into the tip to hook the loop formed in the suture.

16. The instrument as recited in claim 11 in which the suture is a loop and the needle mechanism includes a notch formed along one side of the needle that penetrates through the valve leaflet, the notch being positioned when the needle mechanism is extended into the tip to hook one end of the suture loop disposed therein.

17. The instrument as recited in claim 16 in which another end of the suture loop wraps around the needle mechanism at a point proximal the valve leaflet.

FIG. 1

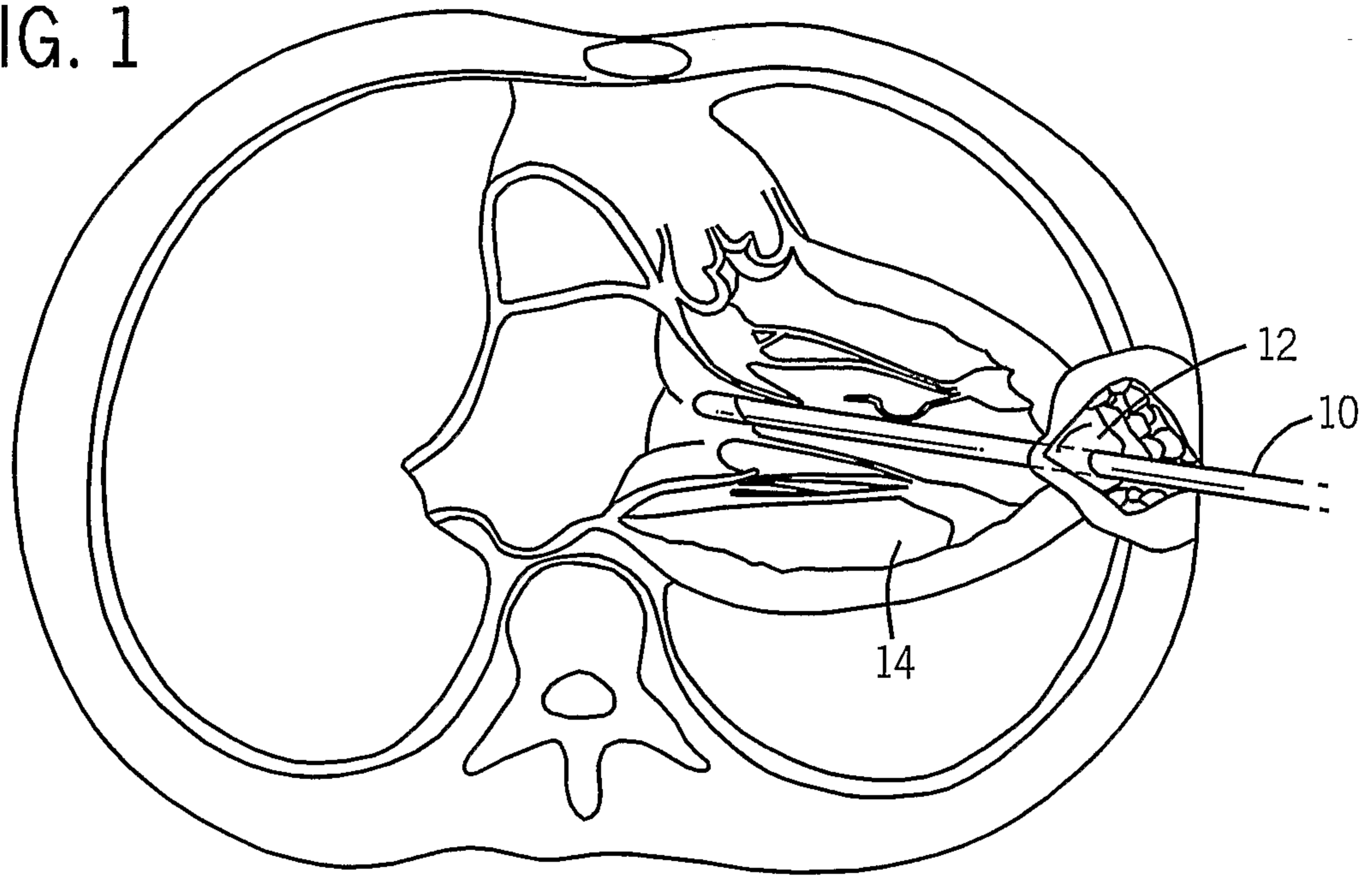

FIG. 2

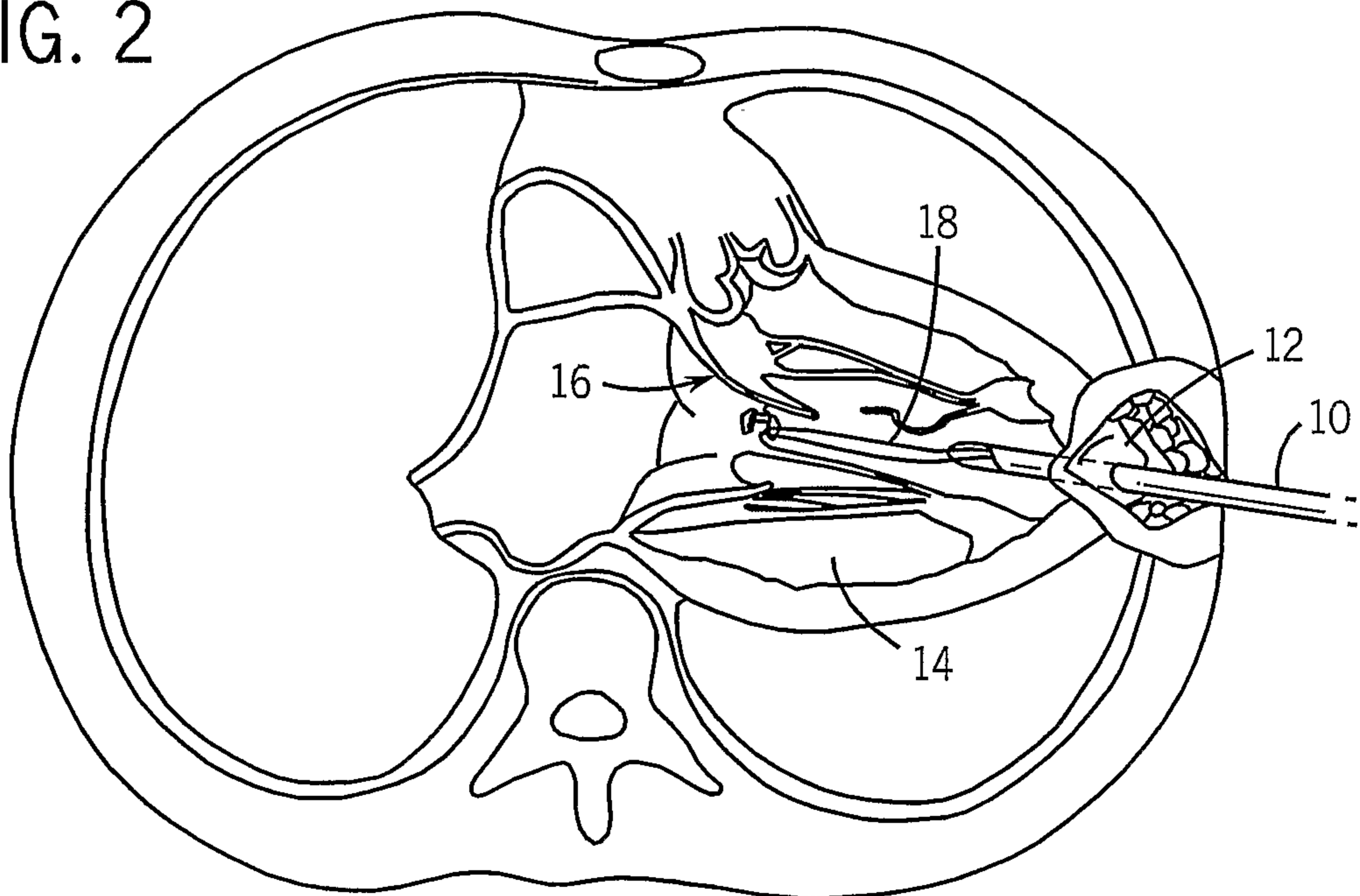

FIG. 3

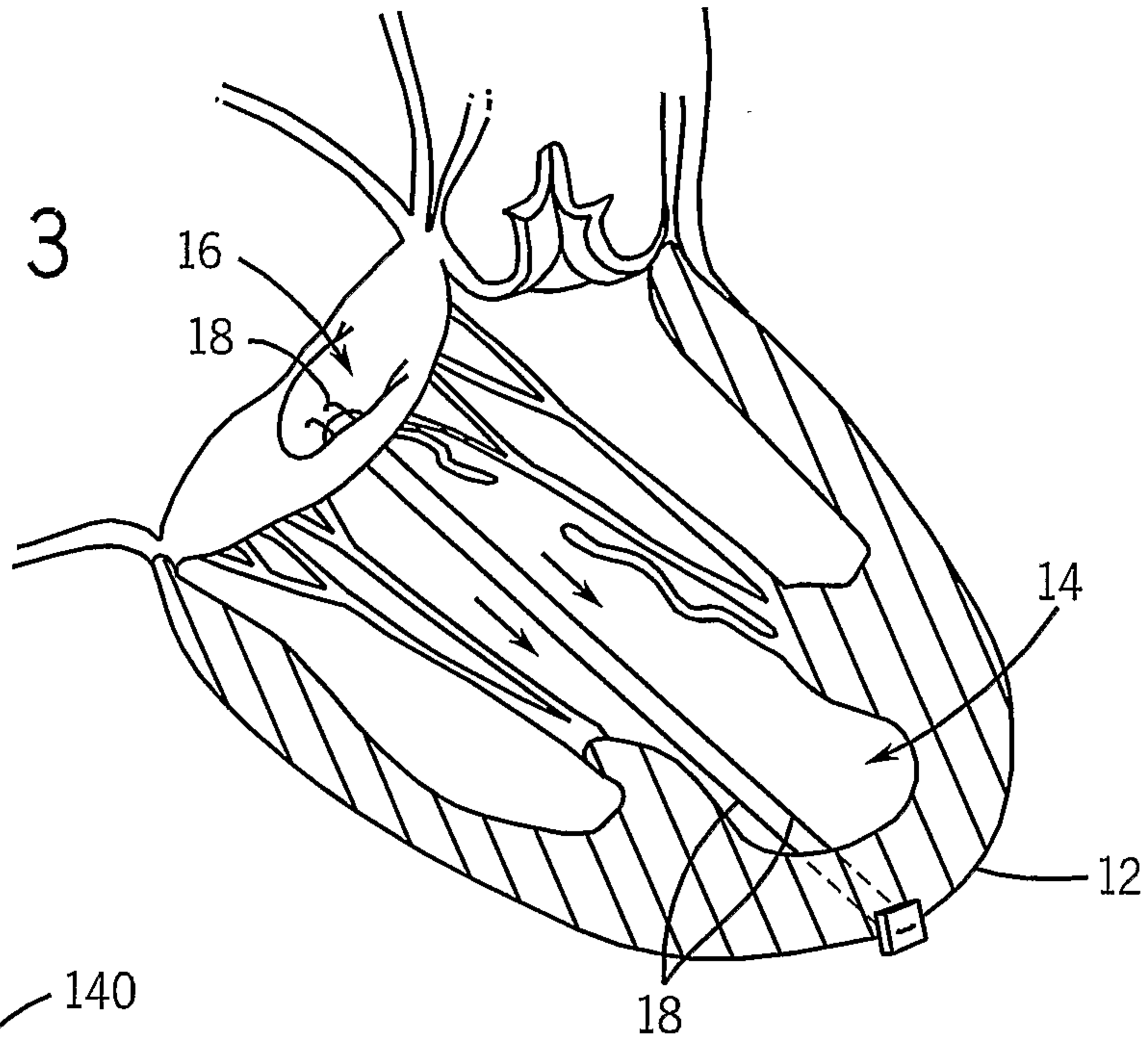

FIG. 4

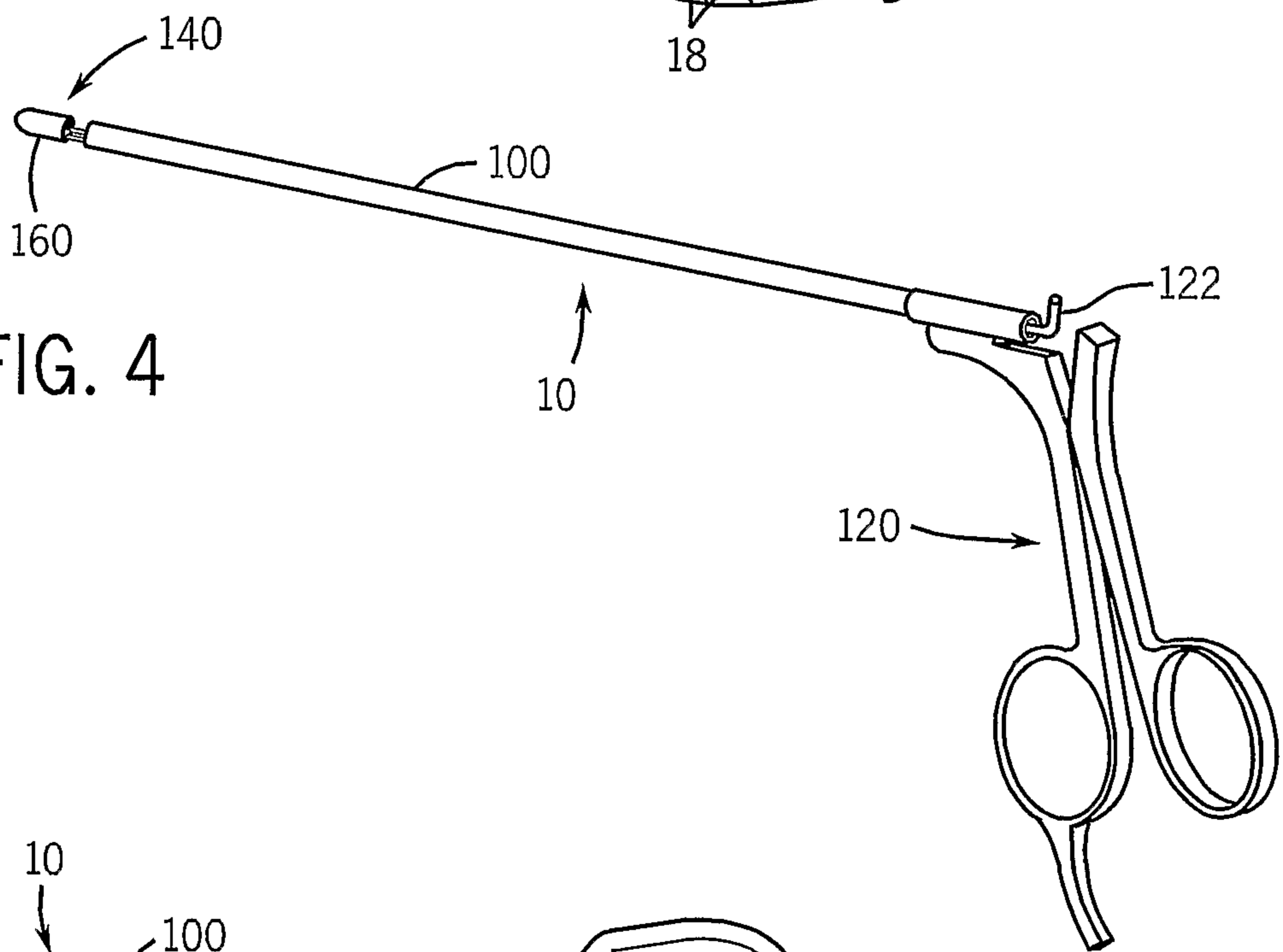
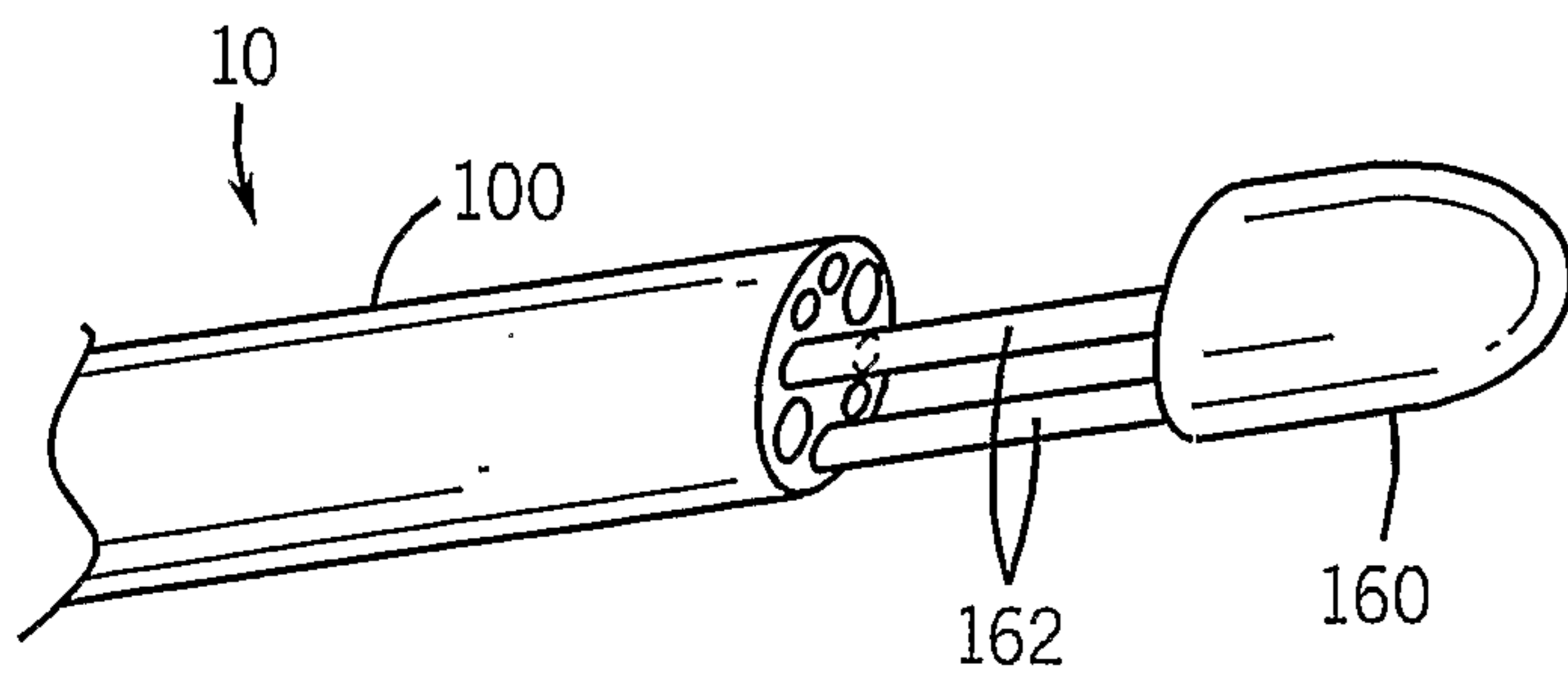

FIG. 5



3 / 10

FIG. 6A

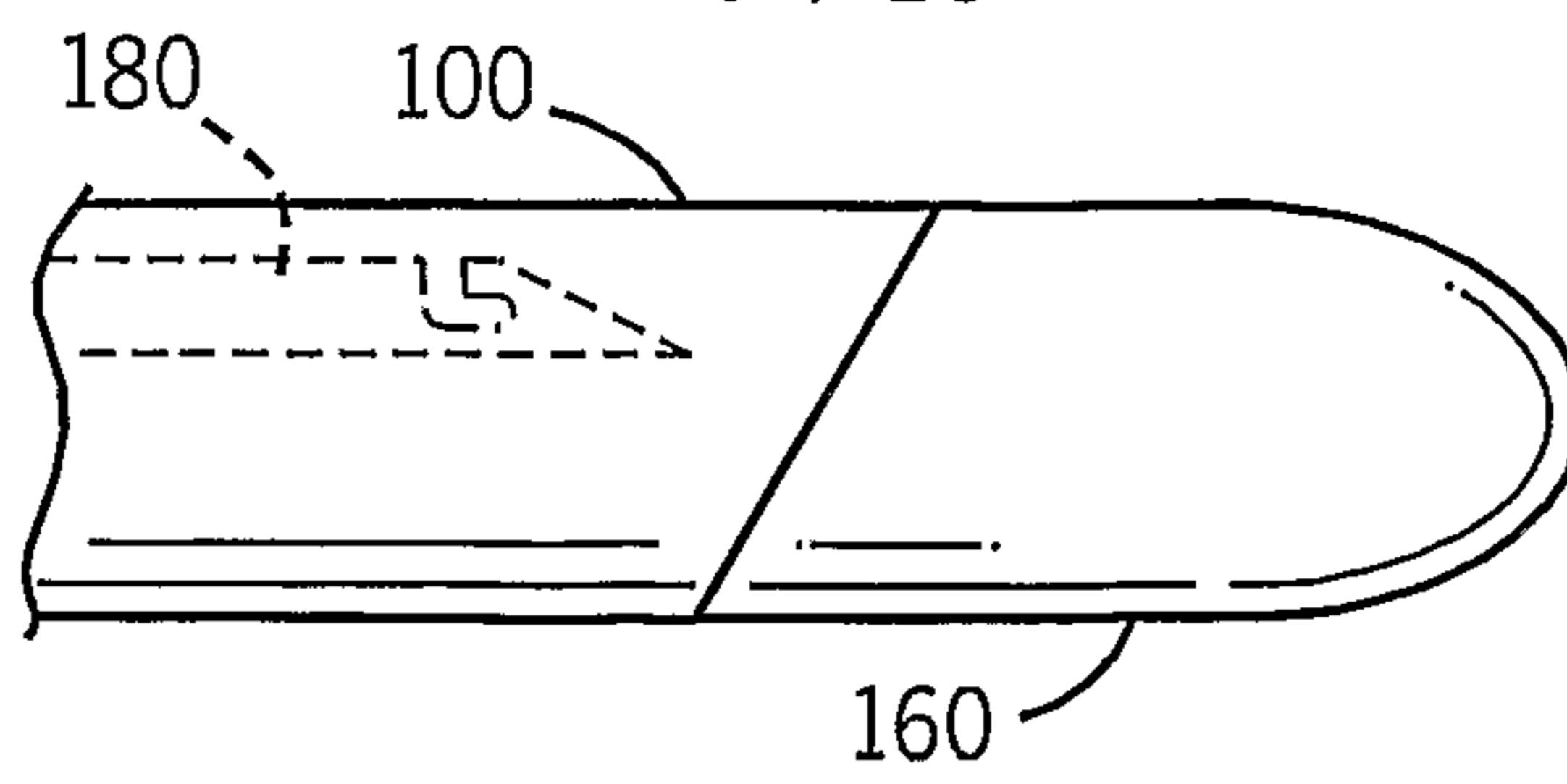

FIG. 6B

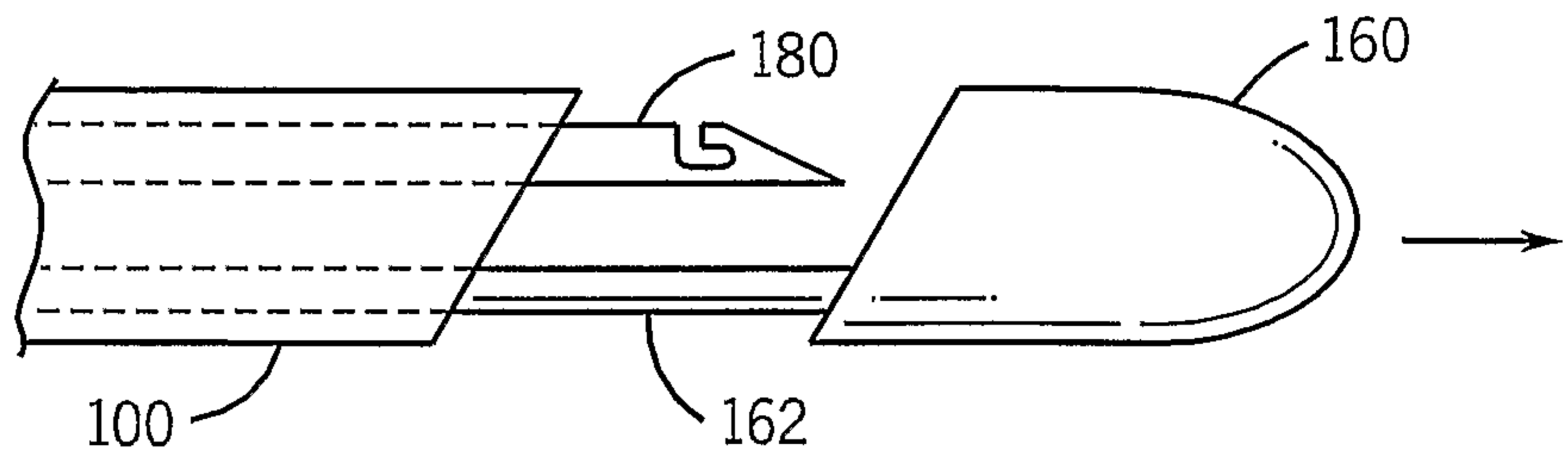

FIG. 7

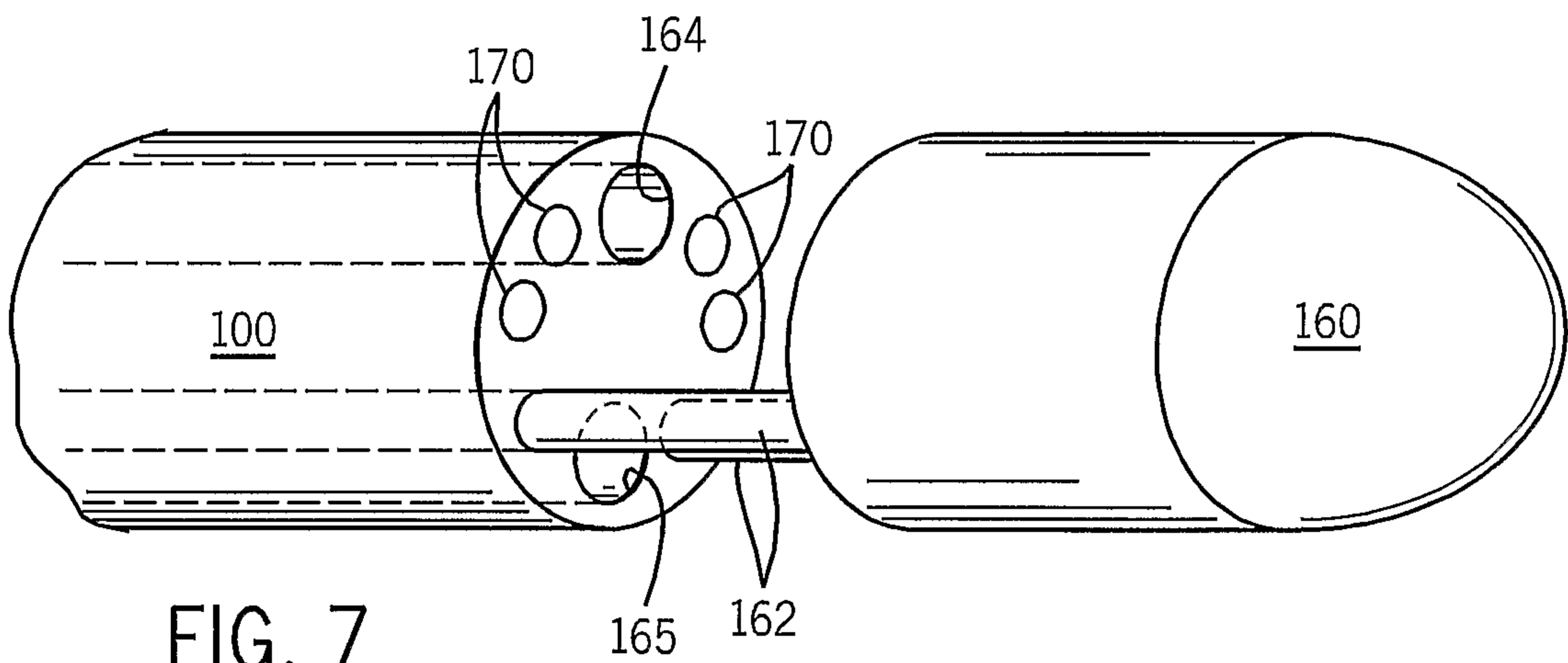
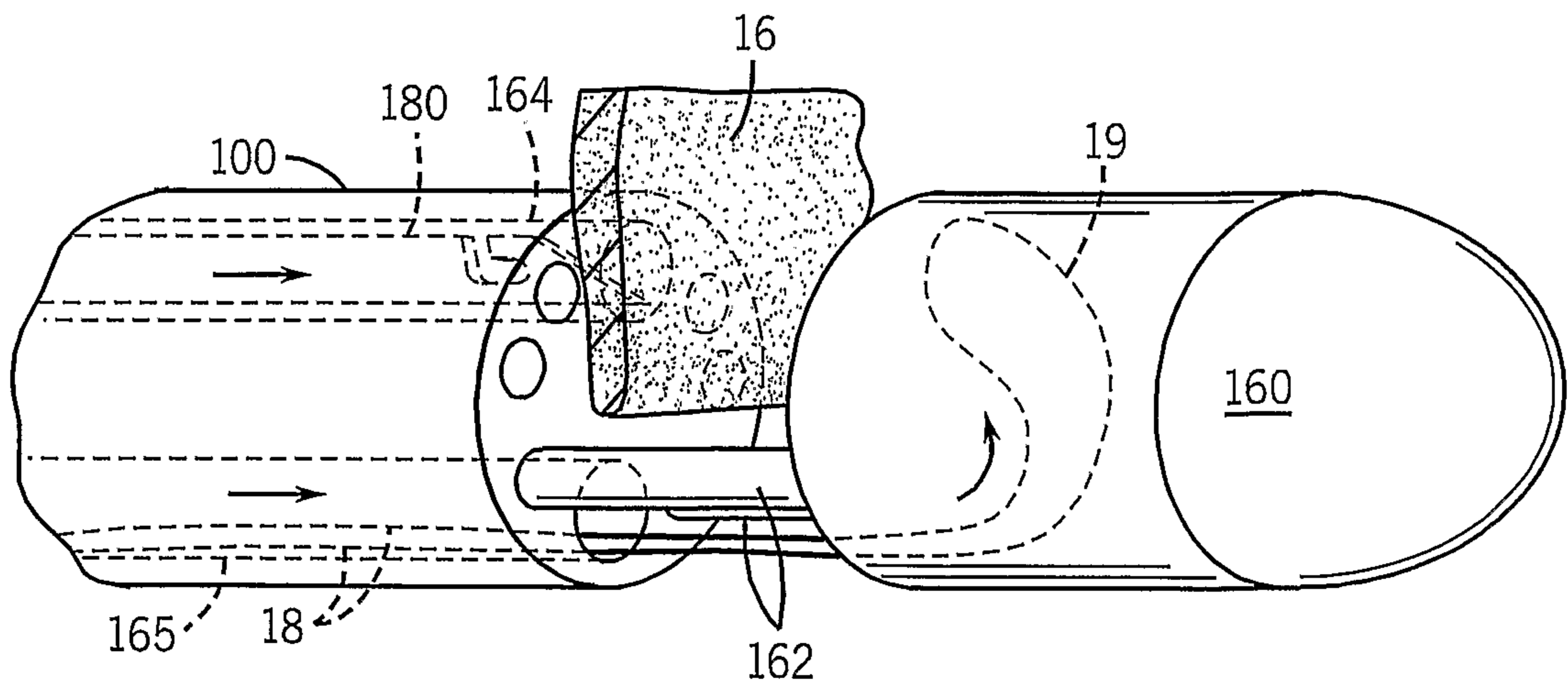

FIG. 8A



4 / 10

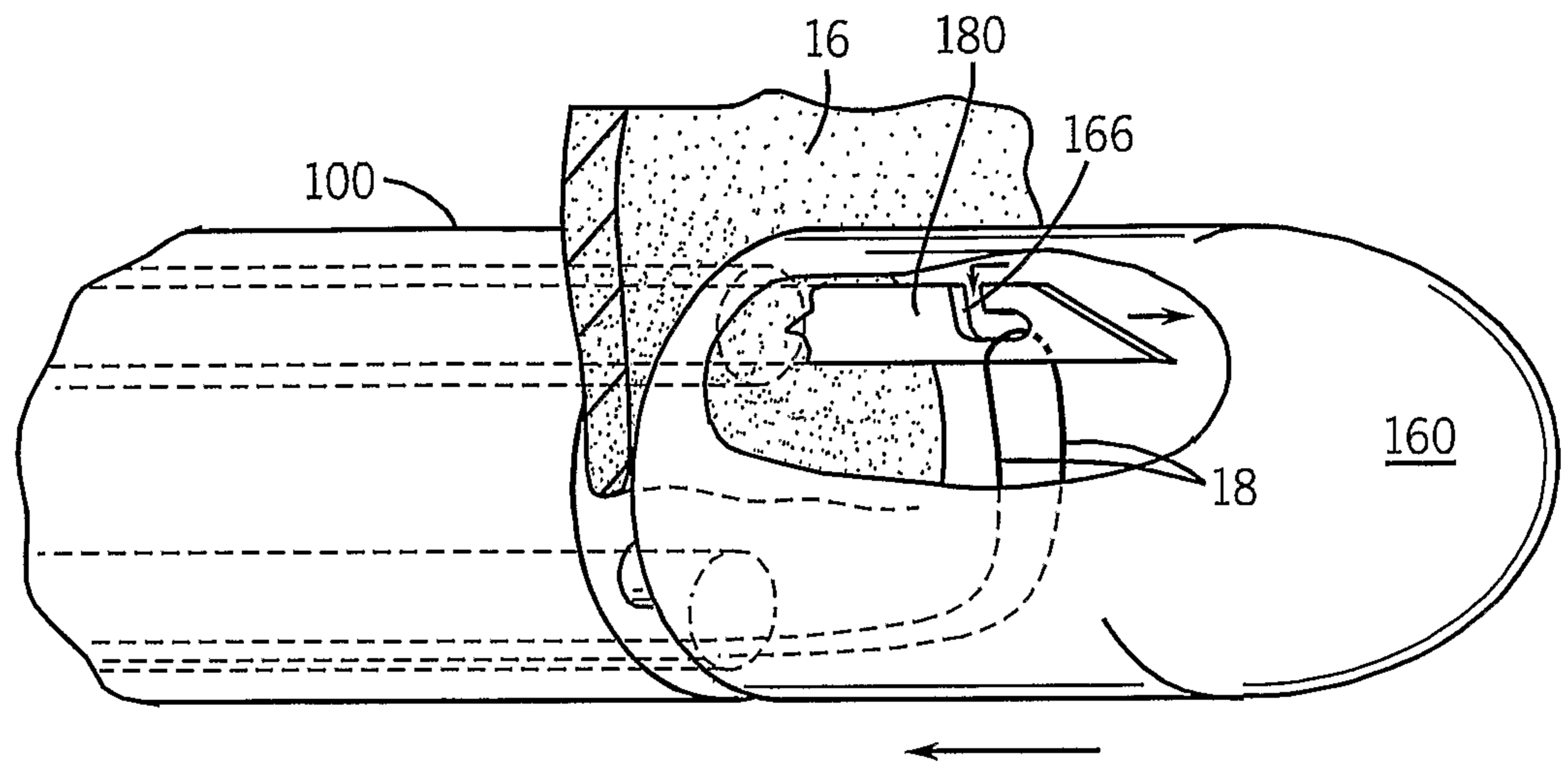

FIG. 8B

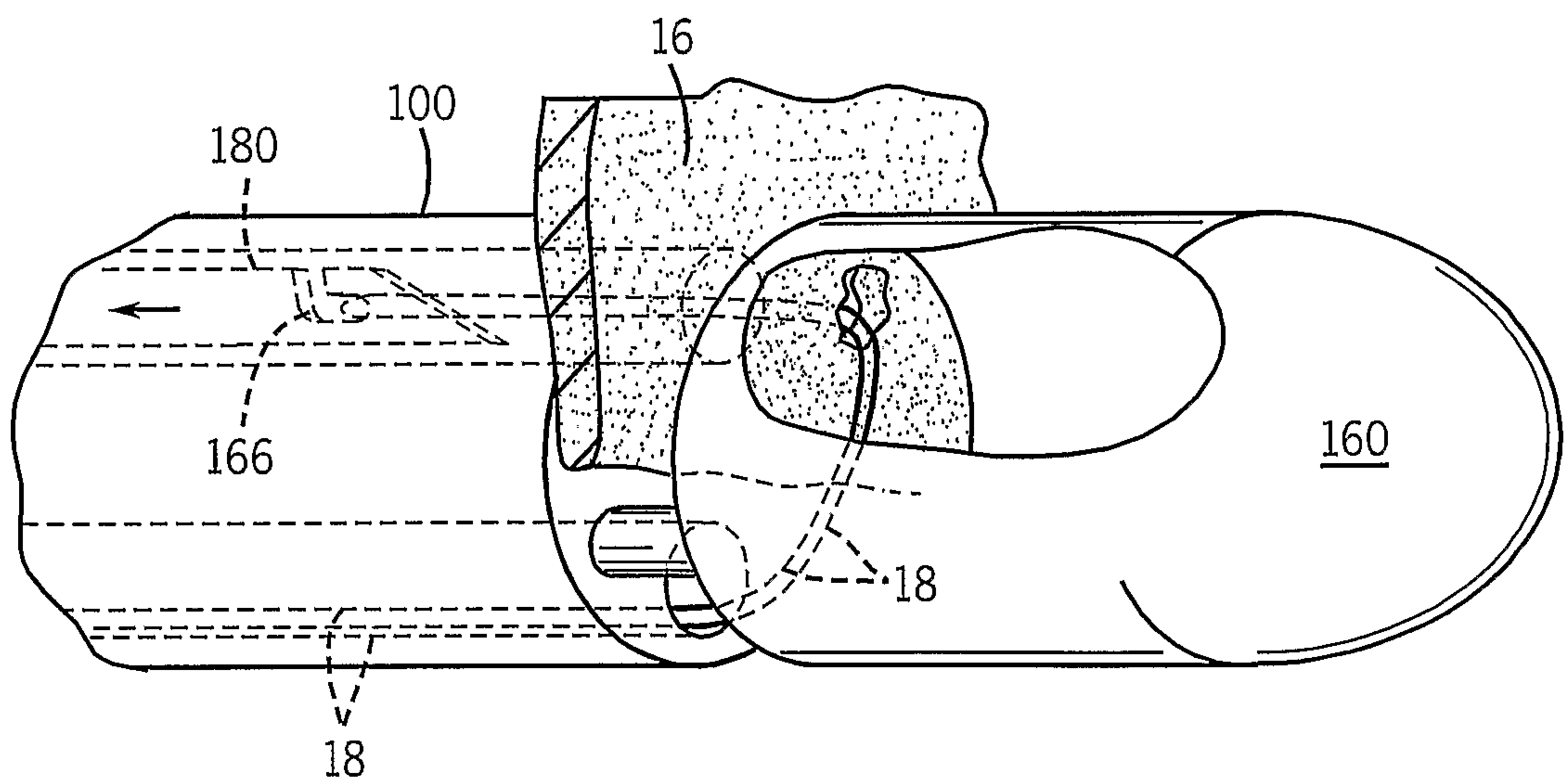

FIG. 8C

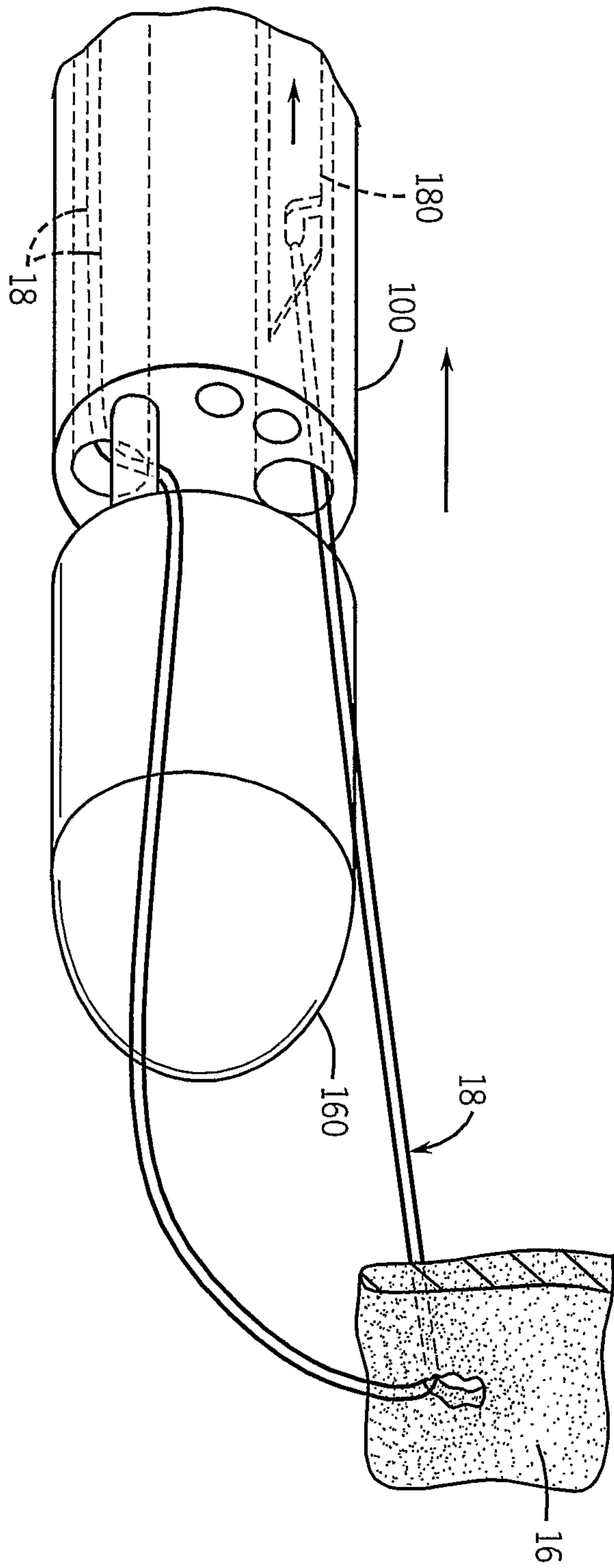

FIG. 8D

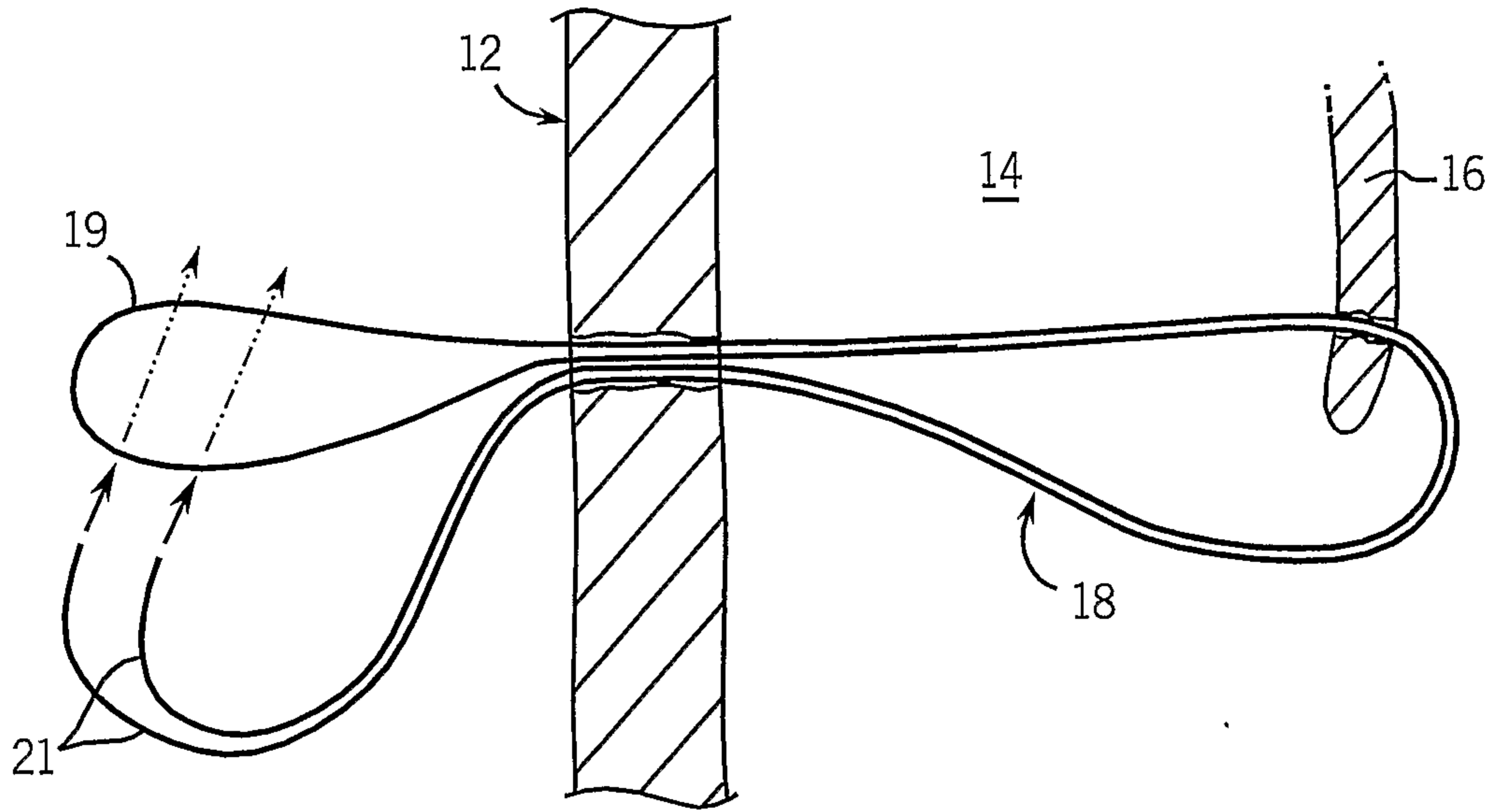

FIG. 8E

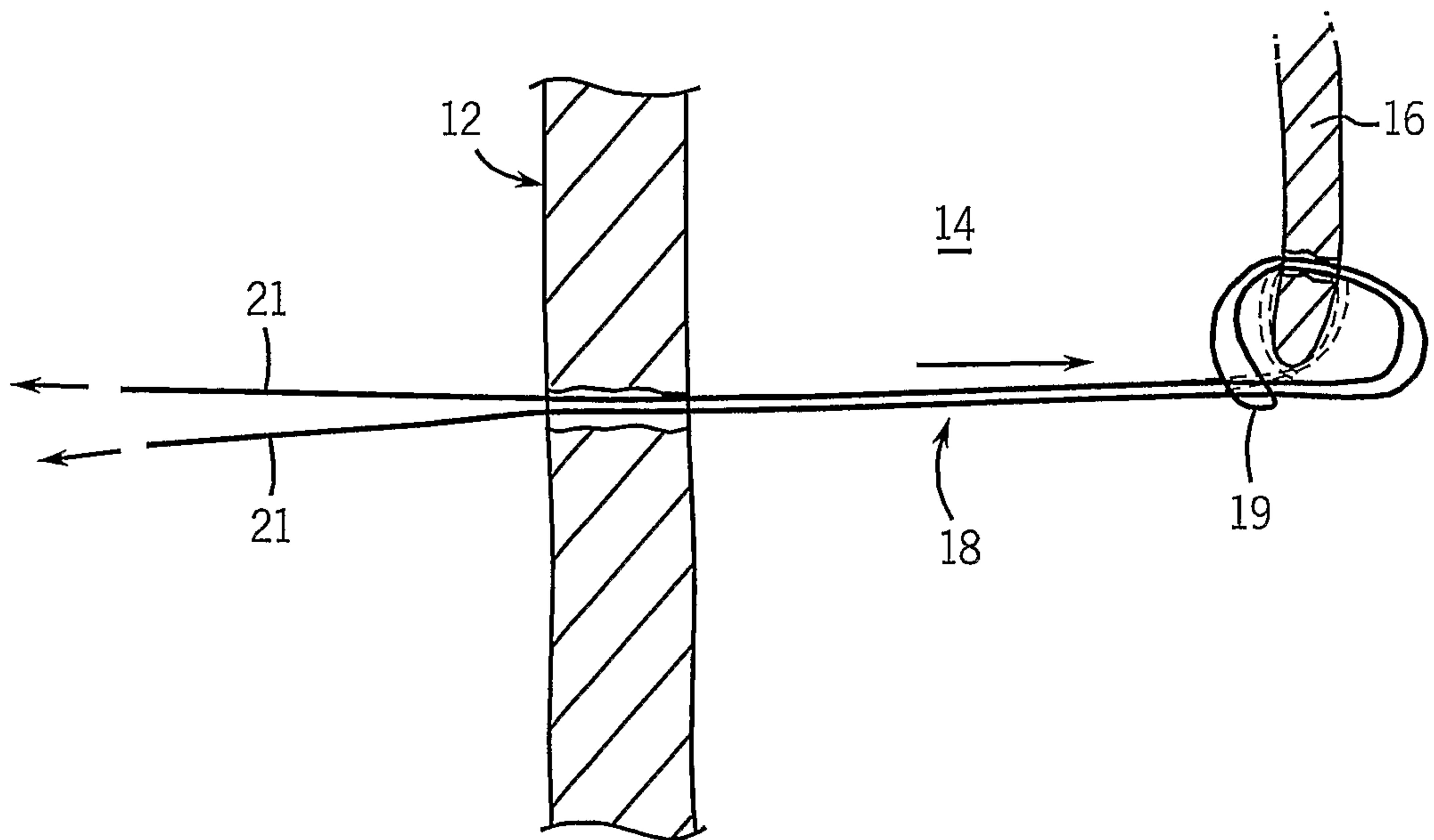

FIG. 8F

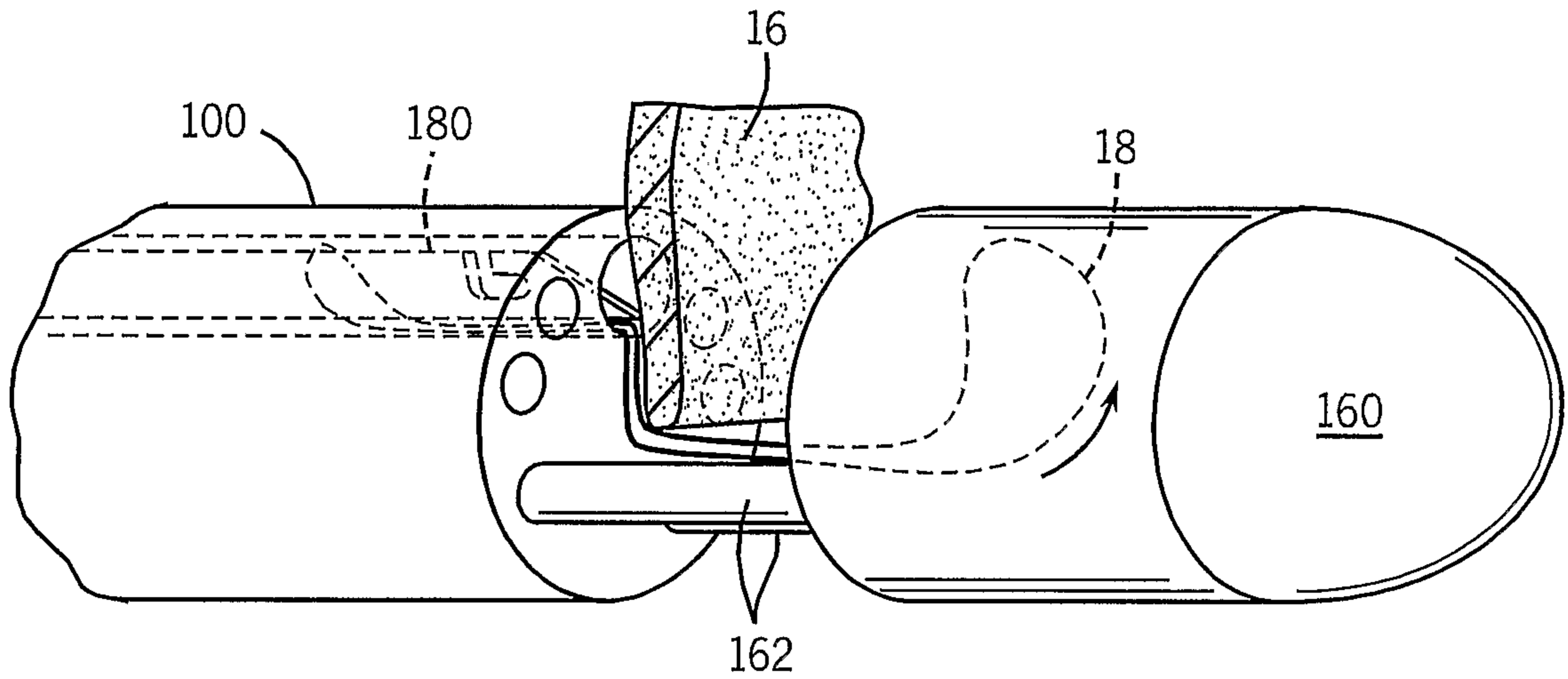

FIG. 9A

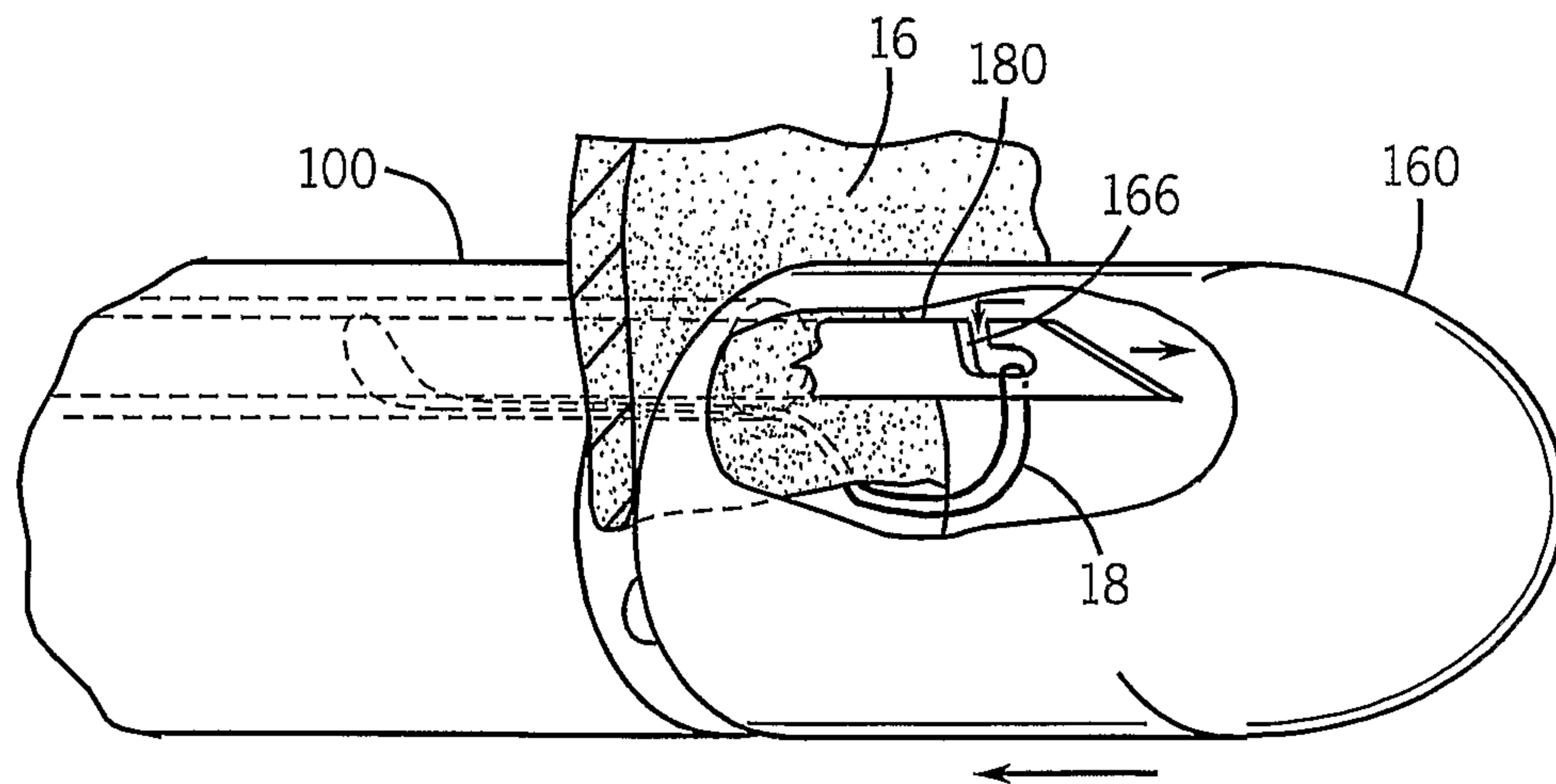

FIG. 9B

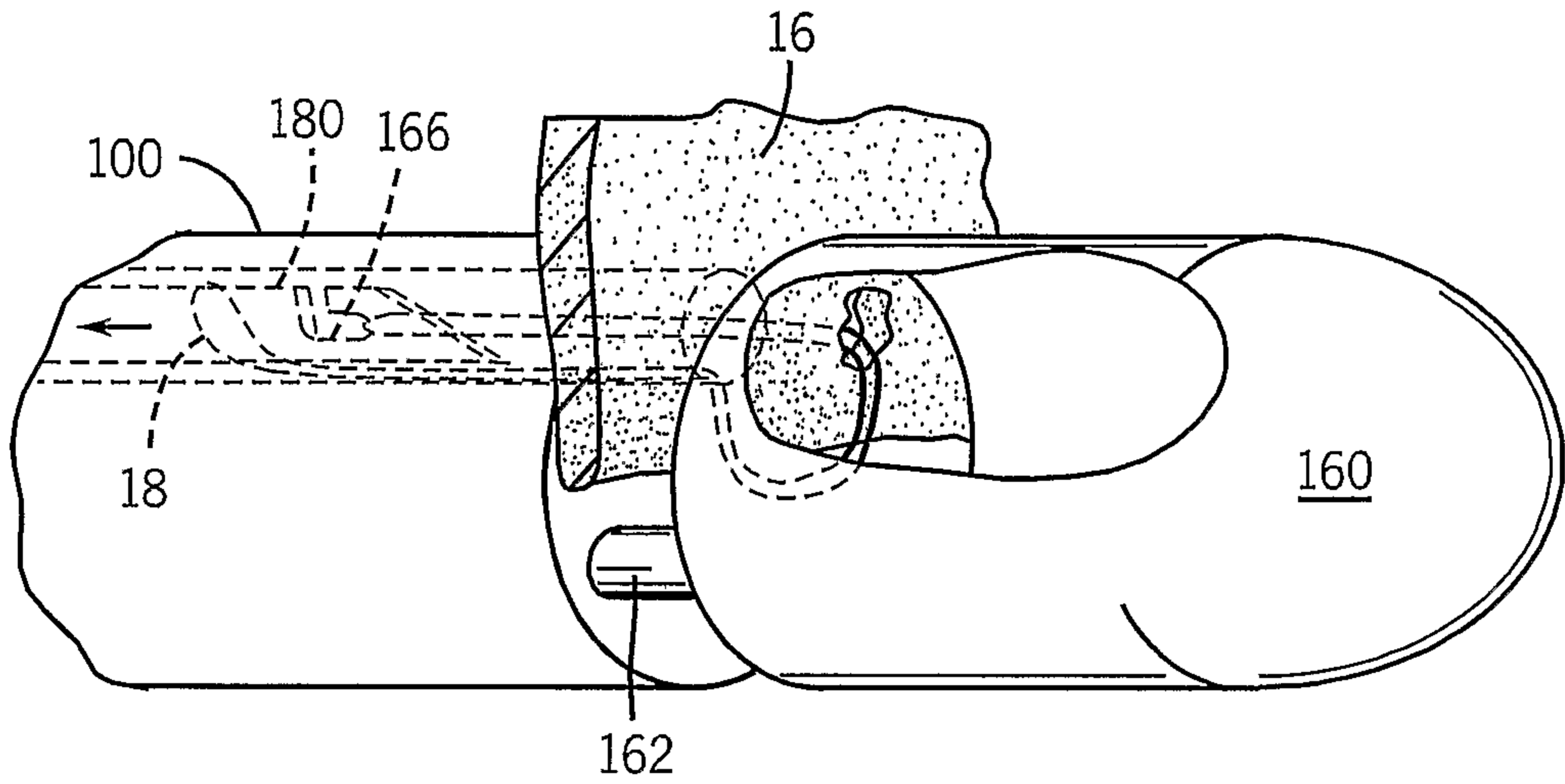

FIG. 9C

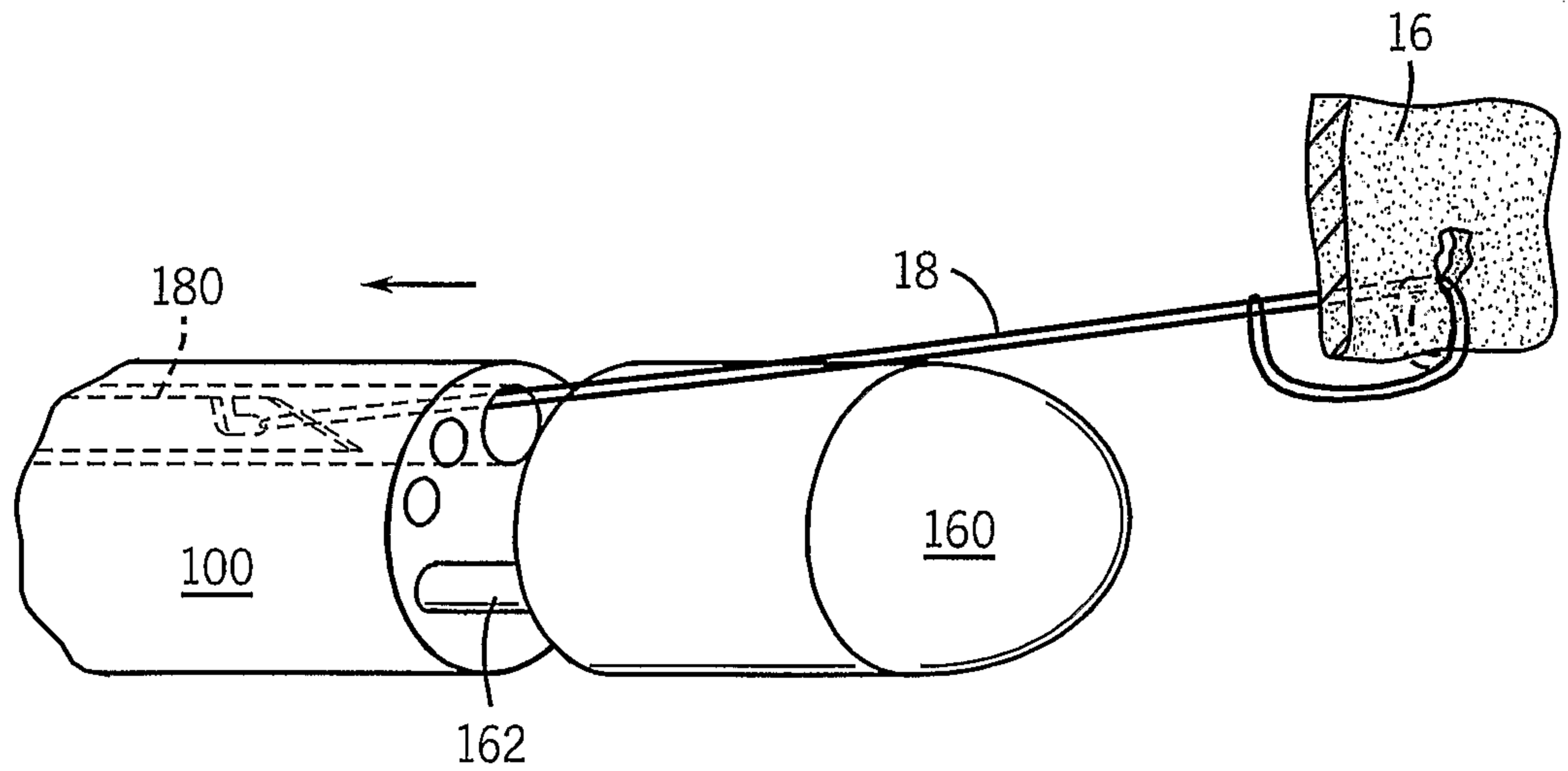

FIG. 9D

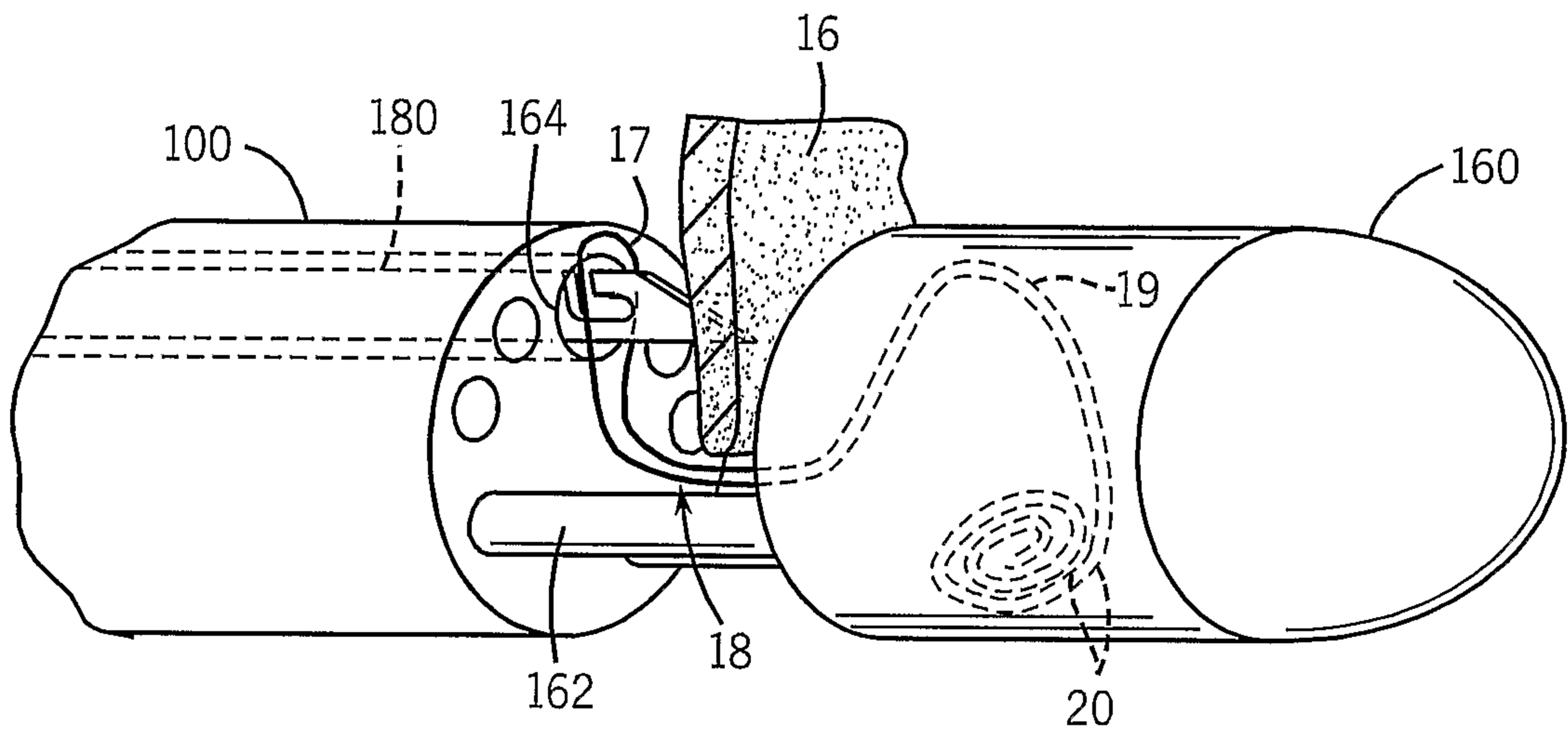

FIG. 10A

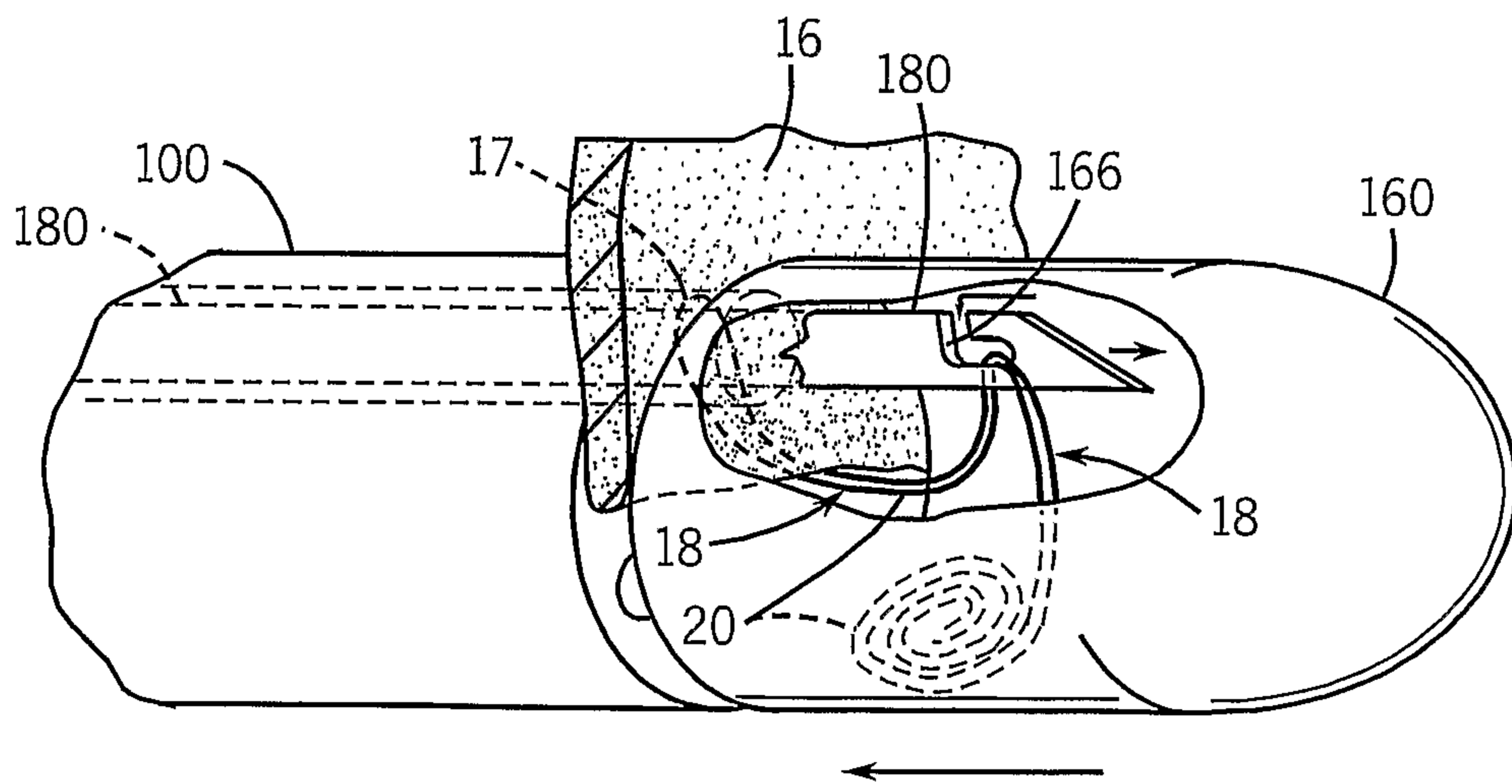

FIG. 10B

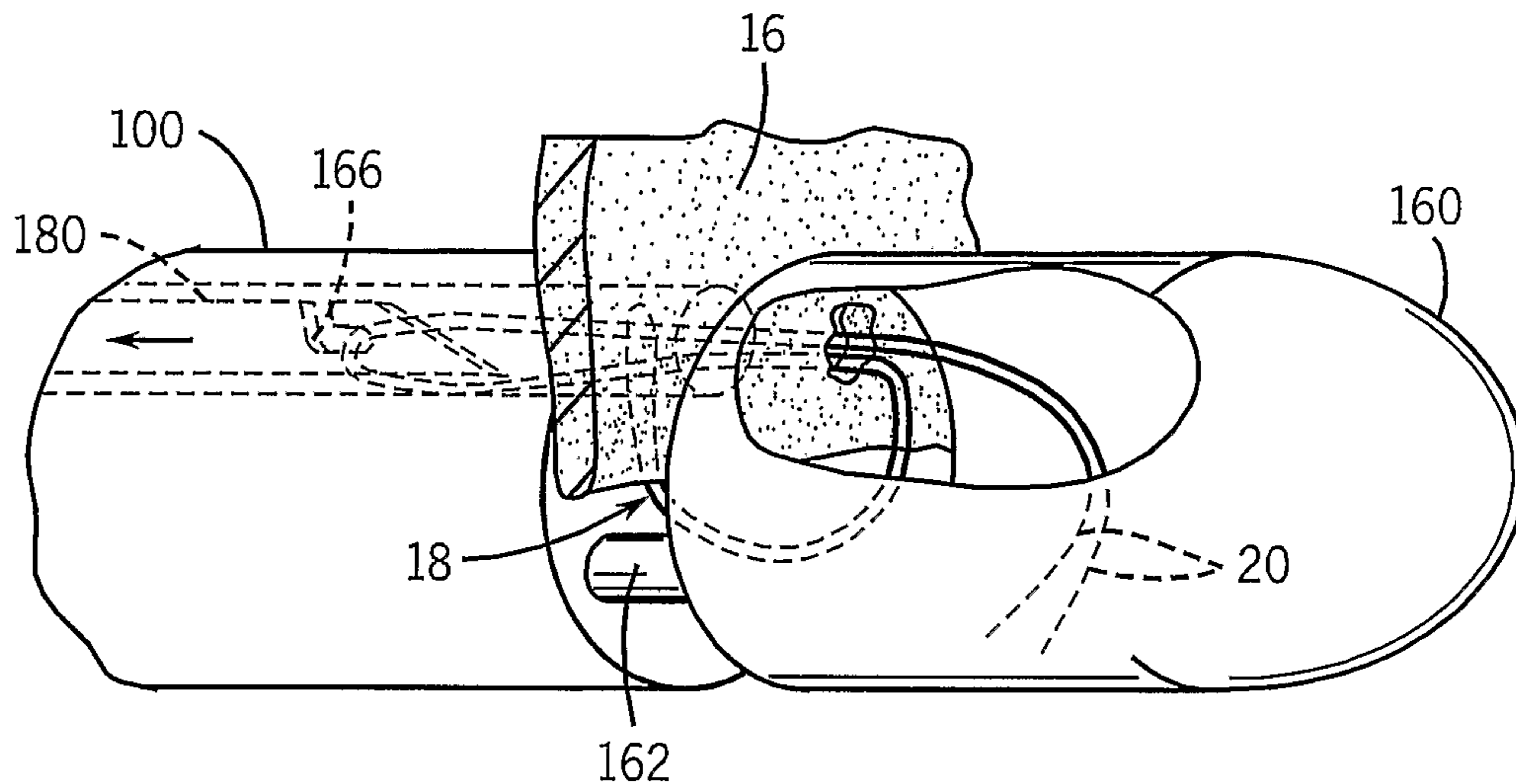

FIG. 10C

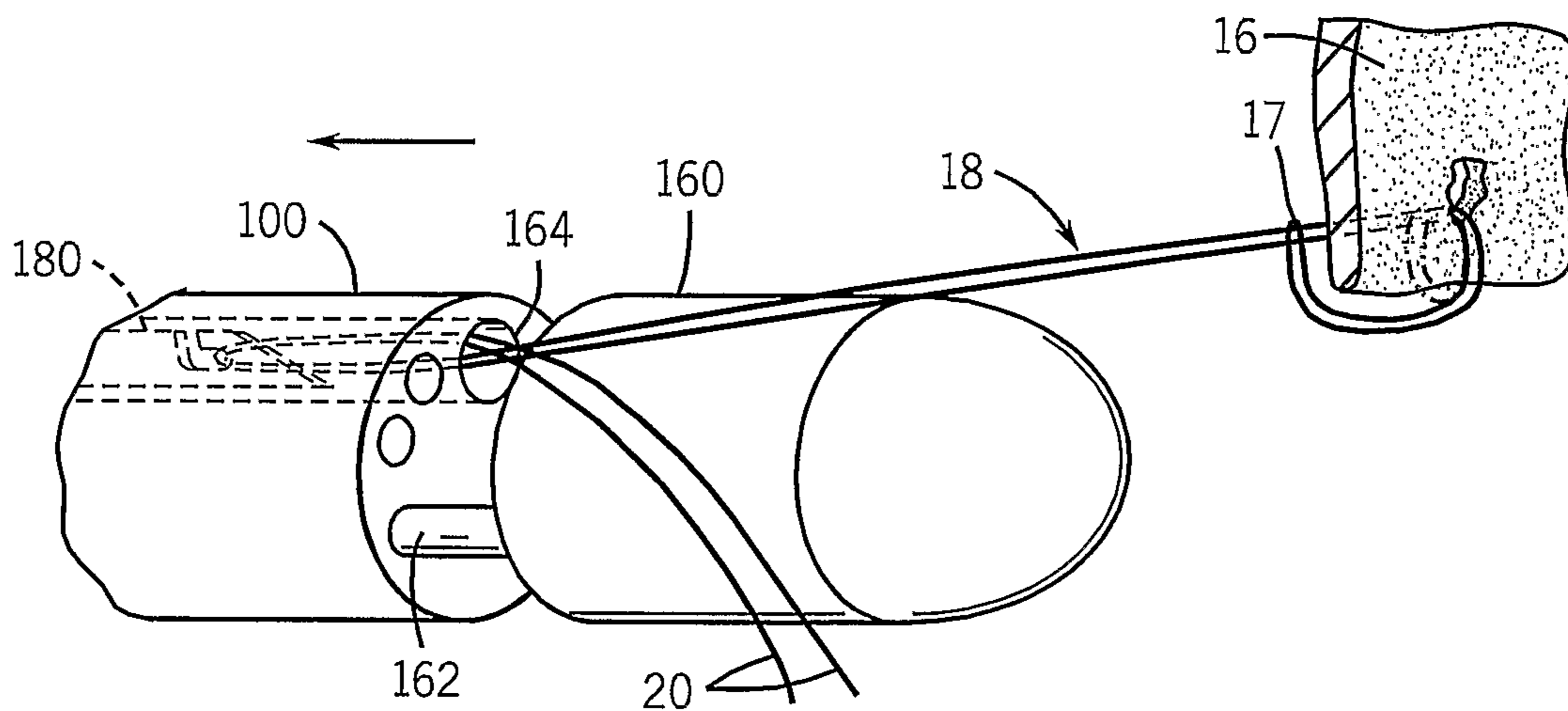

FIG. 10D

