



(19) **United States**

(12) **Patent Application Publication**
Ivanov et al.

(10) **Pub. No.: US 2014/0278393 A1**

(43) **Pub. Date: Sep. 18, 2014**

(54) **APPARATUS AND METHOD FOR POWER EFFICIENT SIGNAL CONDITIONING FOR A VOICE RECOGNITION SYSTEM**

Publication Classification

(71) Applicant: **Motorola Mobility LLC**, Libertyville, IL (US)

(51) **Int. Cl.**
G10L 15/20 (2006.01)
(52) **U.S. Cl.**
CPC *G10L 15/20* (2013.01)
USPC **704/233**

(72) Inventors: **Plamen A. Ivanov**, Schaumburg, IL (US); **Kevin J. Bastry**, Milwaukee, WI (US); **Joel A. Clark**, Woodridge, IL (US); **Mark A. Jasiuk**, Chicago, IL (US); **Tenkasi V. Ramabdran**, Oswego, IL (US); **Jincheng Wu**, Naperville, IL (US)

(57) **ABSTRACT**

A disclosed method includes monitoring an audio signal energy level while having a plurality of signal processing components deactivated and activating at least one signal processing component in response to a detected change in the audio signal energy level. The method may include activating and running a voice activity detector on the audio signal in response to the detected change where the voice activity detector is the at least one signal processing component. The method may further include activating and running the noise suppressor only if a noise estimator determines that noise suppression is required. The method may activate and runs a noise type classifier to determine the noise type based on information received from the noise estimator and may select a noise suppressor algorithm, from a group of available noise suppressor algorithms, where the selected noise suppressor algorithm is the most power consumption efficient.

(73) Assignee: **Motorola Mobility LLC**, Libertyville, IL (US)

(21) Appl. No.: **13/955,186**

(22) Filed: **Jul. 31, 2013**

Related U.S. Application Data

(60) Provisional application No. 61/827,797, filed on May 28, 2013, provisional application No. 61/776,793, filed on Mar. 12, 2013, provisional application No. 61/798,097, filed on Mar. 15, 2013.

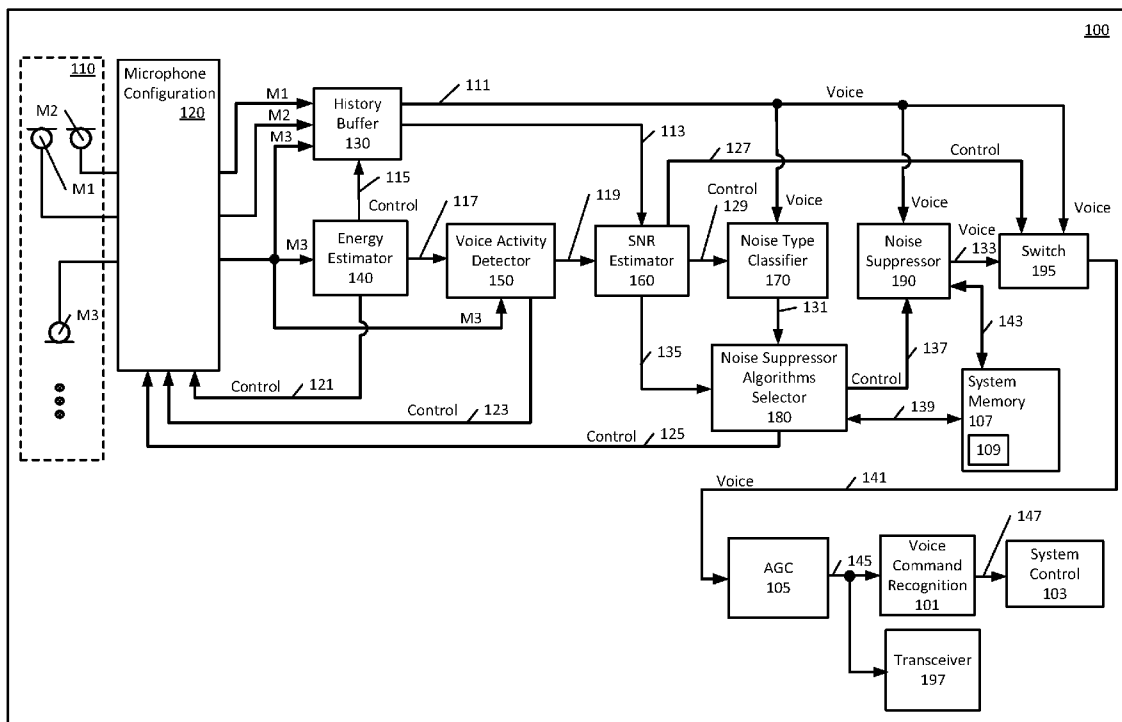

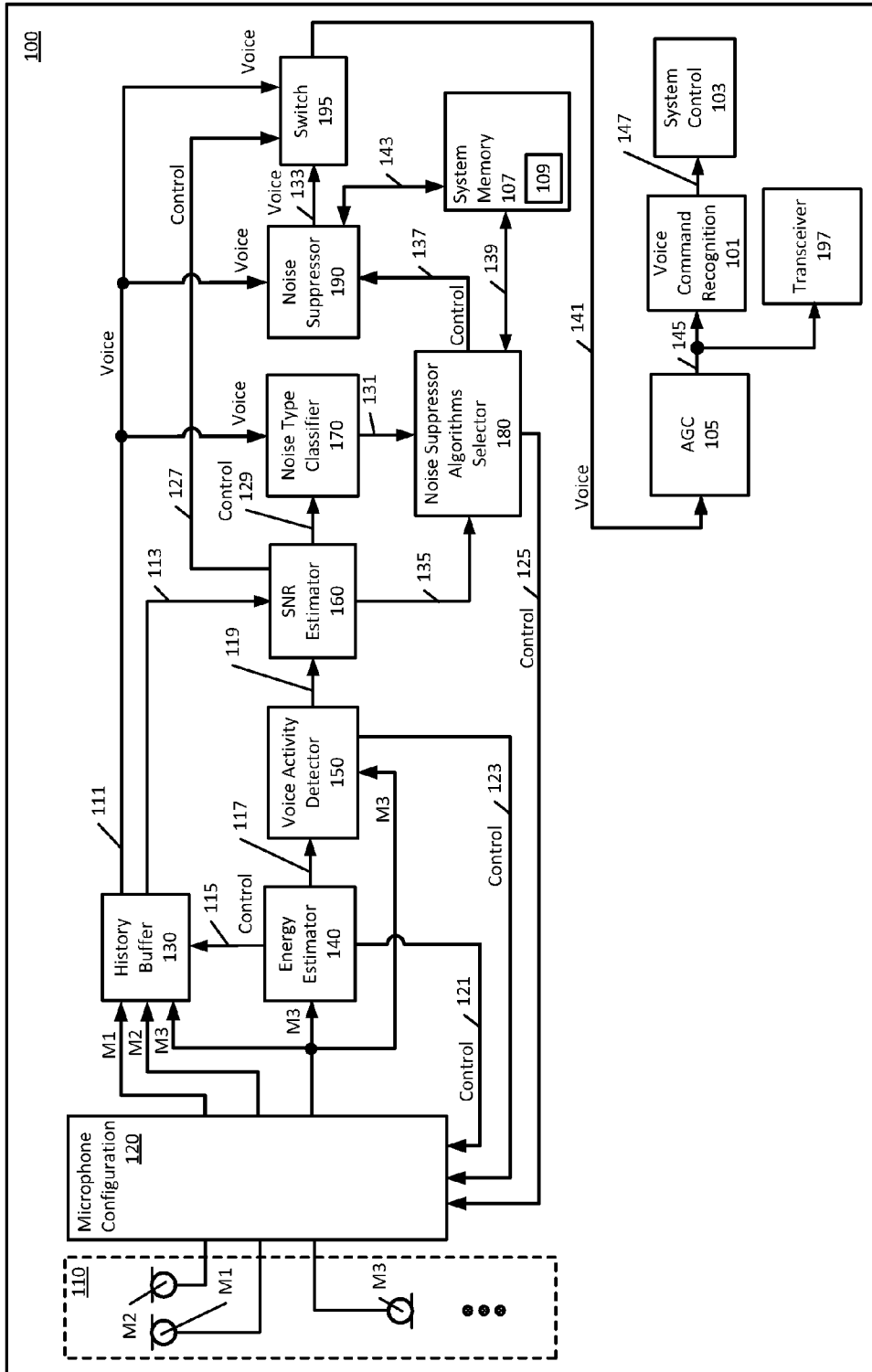

FIG. 1

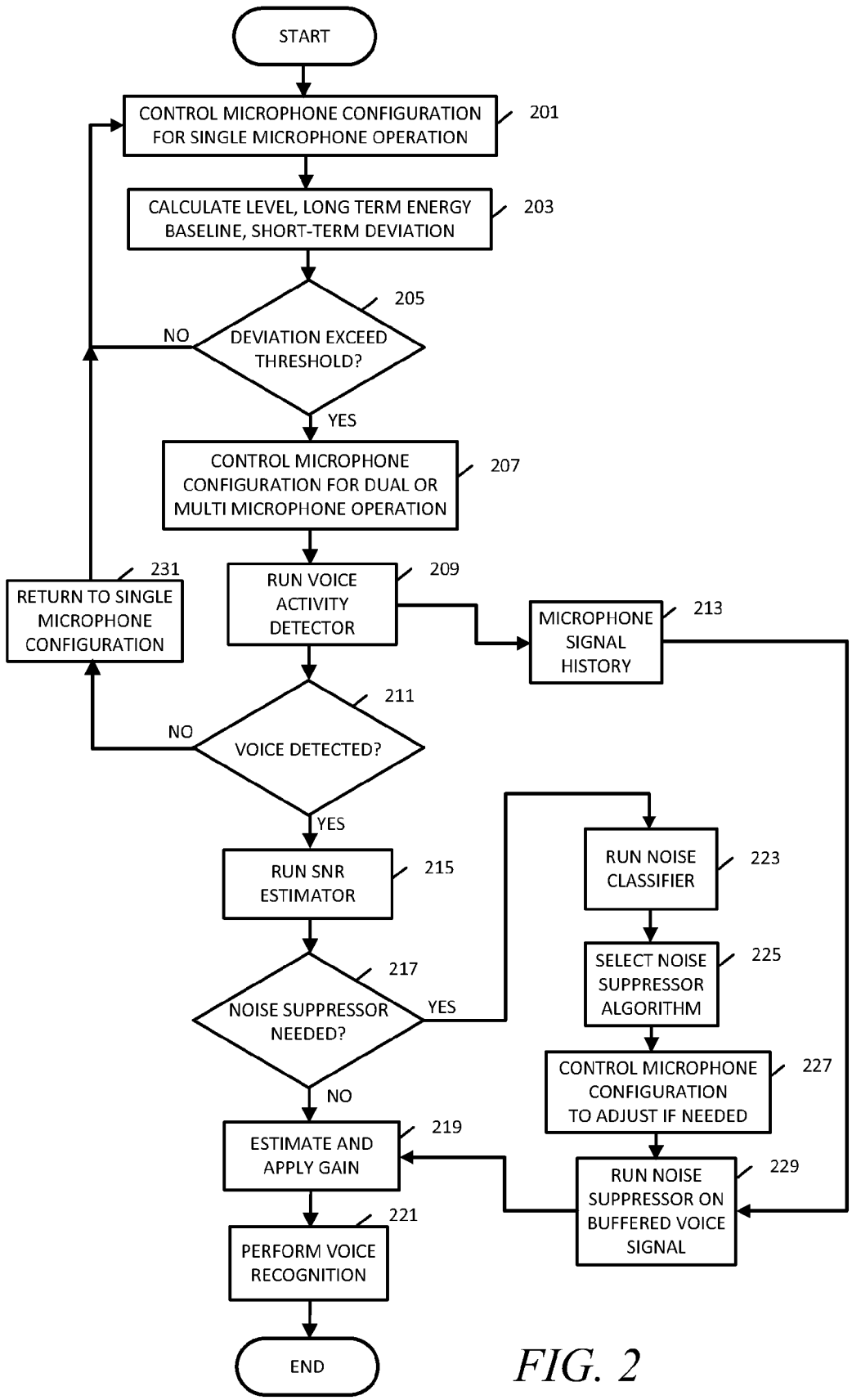

FIG. 2

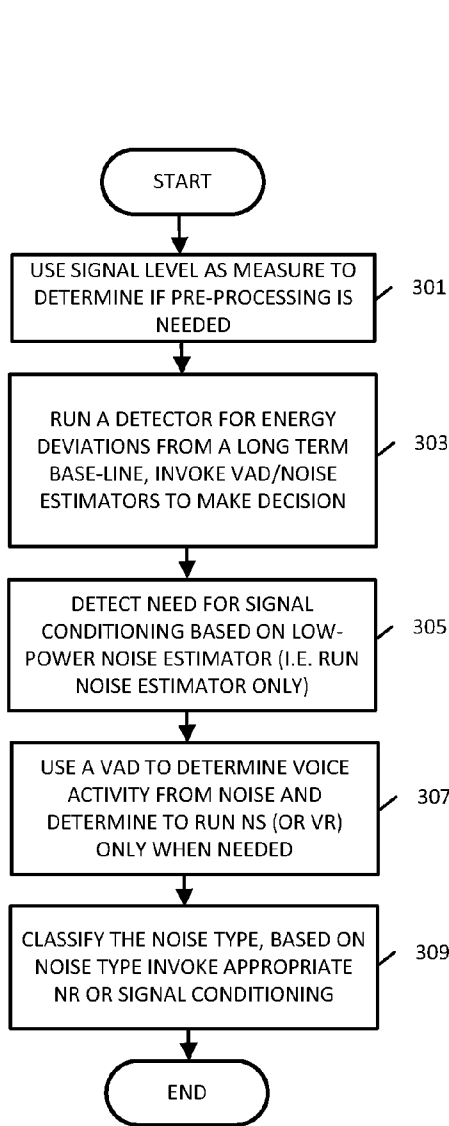

FIG. 3

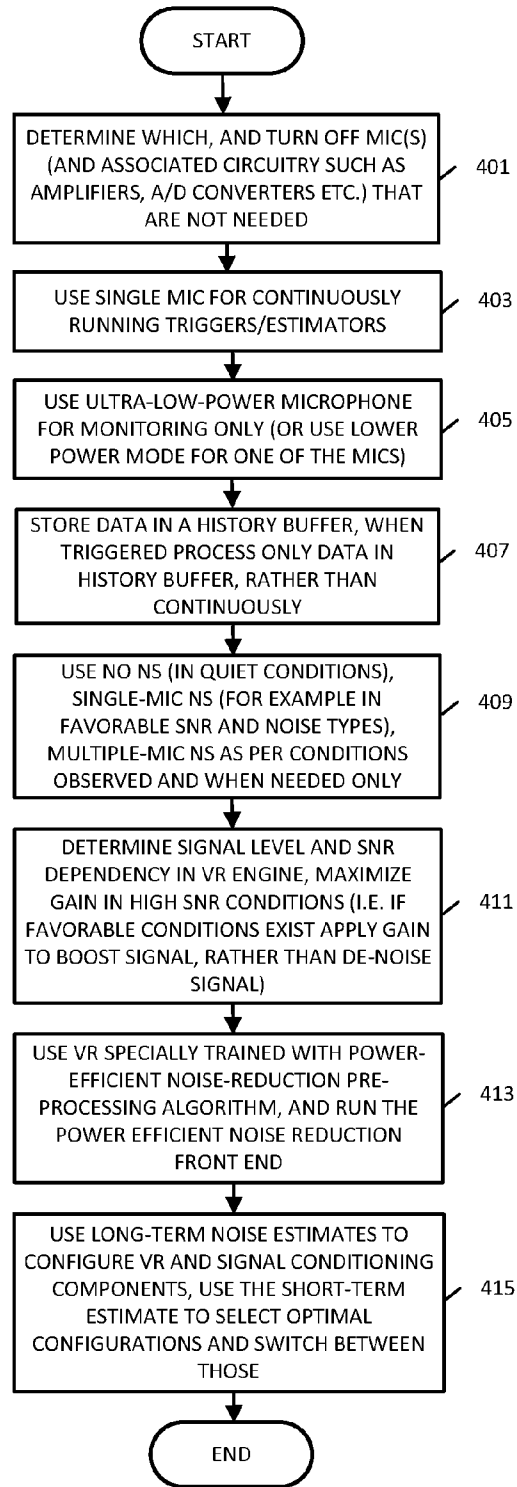

FIG. 4

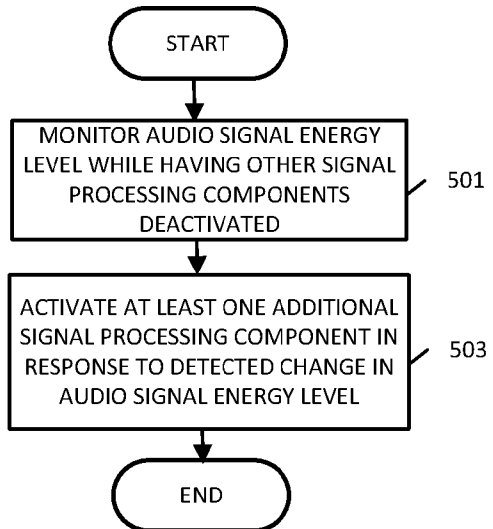

FIG. 5

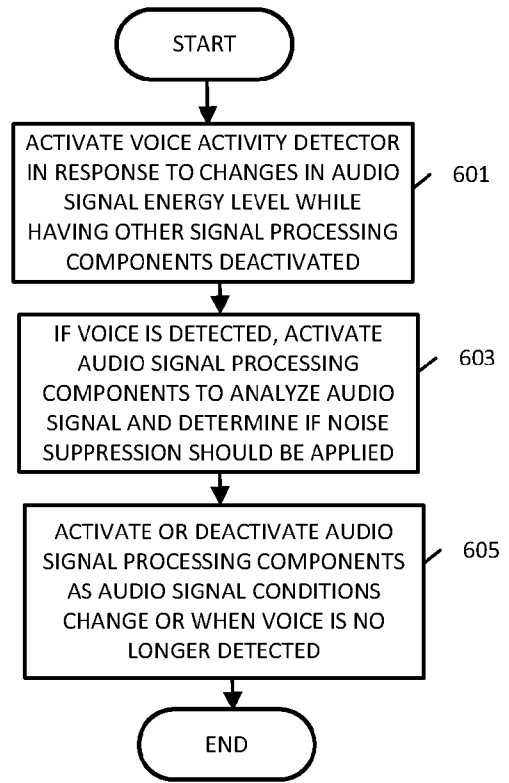

FIG. 6

APPARATUS AND METHOD FOR POWER EFFICIENT SIGNAL CONDITIONING FOR A VOICE RECOGNITION SYSTEM

CROSS-REFERENCE TO RELATED APPLICATIONS

[0001] The present application claims priority to U.S. Provisional Patent Application No. 61/827,797, filed May 28, 2013, entitled "APPARATUS AND METHOD FOR POWER EFFICIENT SIGNAL CONDITIONING IN A VOICE RECOGNITION SYSTEM," and further claims priority to U.S. Provisional Patent Application No. 61/798,097, filed Mar. 15, 2013, entitled "VOICE RECOGNITION FOR A MOBILE DEVICE," and further claims priority to U.S. Provisional Pat. App. No. 61/776,793, filed Mar. 12, 2013, entitled "VOICE RECOGNITION FOR A MOBILE DEVICE," all of which are assigned to the same assignee as the present application, and all of which are hereby incorporated by reference herein in their entirety.

FIELD OF THE DISCLOSURE

[0002] The present disclosure relates generally to voice signal processing and more particularly to voice signal processing for voice recognition systems.

BACKGROUND

[0003] Mobile devices such as, but not limited to, mobile phones, smart phones, personal digital assistants (PDAs), tablets, laptops or other electronic devices, etc., increasingly include voice recognition systems to provide hands free voice control of the devices. Although voice recognition technologies have been improving, accurate voice recognition remains a technical challenge.

[0004] A particular challenge when implementing voice recognition systems on mobile devices is that, as the mobile device moves or is positioned in certain ways, the acoustic environment of the mobile device changes accordingly thereby changing the sound perceived by the mobile device's voice recognition system. Voice sound that may be recognized by the voice recognition system under one acoustic environment may be unrecognizable under certain changed conditions due to mobile device motion or positioning. Various other conditions in the surrounding environment can add noise, echo or cause other acoustically undesirable conditions that also adversely impact the voice recognition system.

[0005] More specifically, the mobile device acoustic environment impacts the operation of signal processing components such as microphone arrays, noise suppressors, echo cancellation systems and signal conditioning that is used to improve voice recognition performance. Such signal processing operations for voice recognition improvement are not power efficient and increase the drain on battery power. Because users expects voice recognition systems to be available as needed, various voice recognition system programs, processes or services may be required to run continuously resulting in further increased power consumption.

BRIEF DESCRIPTION OF THE DRAWINGS

[0006] FIG. 1 is a schematic block diagram of an apparatus in accordance with the embodiments.

[0007] FIG. 2 is a flow chart providing an example method of operation of the apparatus of FIG. 1 in accordance with various embodiments.

[0008] FIG. 3 is a flow chart showing a method of operation related to voice signal detection in accordance with various embodiments.

[0009] FIG. 4 is a flow chart showing a method of operation related to selection of signal processing in accordance with various embodiments.

[0010] FIG. 5 is a flow chart showing a method of operation in accordance with various embodiments.

[0011] FIG. 6 is a flow chart showing a method of operation in accordance with various embodiments.

DETAILED DESCRIPTION

[0012] Briefly, the disclosed embodiments detect when conditions require the use of accurate, and thus less power efficient, signal processing to assist in voice recognition. Such power intensive signal processing is turned off or otherwise disabled to conserve battery power for as long as possible. The disclosed embodiments achieve a progressive increase of accuracy by running more computationally efficient signal processing on fewer resources and making determinations of when to invoke more sophisticated signal processing based on detected changes of conditions. More particularly, based on information obtained from signal observations, decisions may be made to power-off hardware that is not needed. In other words, when conditions improve from the standpoint of voice recognition performance, the amount of signal processing is ramped down which results in more efficient use of resources and decreased battery power consumption.

[0013] Among other advantages of the disclosed embodiments, power consumption is minimized by optimizing voice recognition system operation in every software and hardware layer, including switching off non-essential hardware, running power efficient signal processing and relying on accurate, less power efficient signal processing only when needed to accommodate acoustic environment conditions.

[0014] A disclosed method of operation includes monitoring an audio signal energy level with a plurality of signal processing components deactivated, and activating at least one signal processing component of the plurality of signal processing components in response to a detected change in the audio signal energy level. The method may further include activating and running a voice activity detector on the audio signal in response to the detected change in the audio energy level where the voice activity detector is one of the signal processing components that is otherwise kept deactivated. In one embodiment, a method of operation includes monitoring an audio signal energy level while having a noise suppressor deactivated to conserve battery power, buffering the audio signal in response to a detected change or increase in the audio energy level, activating and running a voice activity detector on the audio signal in response to the detected change or increase in the audio energy level and activating and running a noise estimator in response to voice being detected in the audio signal by the voice activity detector. In some embodiments, the method may further include activating and running the noise suppressor only if the noise estimator determines that noise suppression is required. In some embodiments, the method may further include activating and running a noise type classifier to determine the noise type based on information received from the noise estimator and selecting a noise suppressor algorithm, from a group of available noise suppressor algorithms, based on the noise type. The selected noise suppressor algorithm may also be selected based on

power consumption efficiency for the noise type. The method may further include determining, by the noise estimator, that noise suppression is not required, and performing voice recognition on the buffered audio signal without activating the noise suppressor.

[0015] The method may also include applying gain to the buffered audio signal prior to performing voice recognition. The method may include activating additional microphones to receive audio in response to the detected increase in the audio energy level. The method of operation may deactivate the additional microphones and return to a single microphone configuration in response to voice not being detected in the audio signal by the voice activity detector. The energy estimator calculates a long term energy baseline and a short term deviation from it, and monitors the audio signal energy level while having a noise suppressor, or other signal processing components, deactivated to conserve battery power. The method of operation may include buffering the audio signal in response to a detected short term deviation.

[0016] A disclosed apparatus in one embodiment includes a noise suppressor, a voice activity detector and an energy estimator that is operatively coupled to the voice activity detector. The energy estimator is operative to monitor an audio signal energy level with at least the noise suppressor and the voice activity detector deactivated. Upon detecting a change in the audio signal energy level, the voice activity detector is operative to activate at least the voice activity detector in response to the detected change. In one embodiment, a disclosed apparatus includes voice recognition logic, a noise suppressor operatively coupled to the voice recognition logic, an energy estimator operative to monitor an audio signal energy level while the noise suppressor is deactivated to conserve battery power, and a voice activity detector operatively coupled to the energy estimator. The voice activity detector is operative to activate in response to a first activation control signal from the energy estimator. A noise estimator is operatively coupled to the voice activity detector. The noise estimator is operative to activate in response to a second activation control signal from the voice activity detector.

[0017] In various embodiments, the apparatus may include a buffer that is operatively coupled to the voice recognition logic and the energy estimator. The buffer is operative to receive a control signal from the energy estimator and to buffer the audio signal in response to the control signal. The energy estimator may be further operative to send the first activation control signal to the voice activity detector in response to a detected change or increase in the audio signal energy level. The voice activity detector is operative to send the second activation control signal to the noise estimator in response to detecting voice in the audio signal.

[0018] In various embodiments, the apparatus may include a switch that is operatively coupled to the voice recognition logic, the noise suppressor and the noise estimator. The noise estimator may actuate the switch to switch the audio signal sent to the voice recognition logic from a buffered audio signal to a noise suppressed audio signal output by the noise suppressor. The apparatus may further include a noise suppressor algorithms selector, operatively coupled to the noise estimator and to the noise suppressor. The noise suppressor algorithms selector operative to activate and run the noise suppressor in response to a noise estimator control signal sent when the noise estimator determines that noise suppression is required.

[0019] In some embodiments, the apparatus may further include a noise type classifier, operatively coupled to the noise estimator and to the noise suppressor algorithms selector. The noise type classifier is operative to activate and run in response to a control signal from the noise estimator, and is operative to determine noise type based on information received from the noise estimator. The noise suppressor algorithms selector may be further operative to select a noise suppressor algorithm, from a group of available noise suppressor algorithms, where the selected noise suppressor algorithm is the most power consumption efficient for the noise type. The noise estimator may also be operative to determine that noise suppression is not required and actuate the switch to switch the audio signal sent to the voice recognition logic from a noise suppressed audio signal output by the noise suppressor to a buffered audio signal.

[0020] In some embodiments, the apparatus includes a plurality of microphones and microphone configuration logic that includes, among other things, switch logic operative to turn each microphone on or off. The energy estimator is further operative to control the microphone configuration logic to turn on additional microphones in response to a detected change or increase in the audio signal energy level. The voice activity detector may be further operative to deactivate the additional microphones and return to a single microphone configuration, or to a low power mode of that microphone, in response to voice not being detected in the audio signal by the voice activity detector.

[0021] Turning now to the drawings, FIG. 1 is a schematic block diagram of an apparatus 100 which is a voice recognition system in accordance with various embodiments. The apparatus 100 may be incorporated into and used in various battery-powered electronic devices that employ voice-recognition. That is, the apparatus 100 may be used in any of various mobile devices such as, but not limited to, a mobile telephone, smart phone, camera, video camera, tablet, laptop, audio recorder or some other battery-powered electronic device, etc.

[0022] It is to be understood that the FIG. 1 schematic block diagram is limited, for the purpose of clarity, to showing only those components useful to describe the features and advantages of the various embodiments, and to describe how to make and use the various embodiments to those of ordinary skill. It is therefore to be understood that various other components, circuitry, and devices etc. may be present in order to implement an apparatus and that those various other components, circuitry, devices, etc., are understood to be present by those of ordinary skill. For example, the apparatus may include inputs for receiving power from a power source and a power bus that may be connected to a battery housed within one of the various battery powered electronic devices such as mobile devices, etc. to provide power to the apparatus 100 or to distribute power to the various components of the apparatus 100.

[0023] Another example is that the apparatus 100 may also include an internal communication bus, for providing operative coupling between the various components, circuitry, and devices. The terminology "operatively coupled" as used herein refers to coupling that enables operational and/or functional communication and relationships between the various components, circuitry, devices etc. described as being operatively coupled and may include any intervening items (i.e. buses, connectors, other components, circuitry, devices etc.) used to enable such communication such as, for example,

internal communication buses such as data communication buses or any other intervening items that one of ordinary skill would understand to be present. Also, it is to be understood that other intervening items may be present between “operatively coupled” items even though such other intervening items are not necessary to the functional communication facilitated by the operative coupling. For example, a data communication bus may be present in various embodiments and may provide data to several items along a pathway along which two or more items are operatively coupled, etc. Such operative coupling is shown generally in FIG. 1 described herein.

[0024] In FIG. 1 the apparatus 100 may include a group of microphones 110 that provide microphone outputs and that are operatively coupled to microphone configuration logic 120. Although the example of FIG. 1 shows three microphones, the embodiments are not limited to three microphones and any number of microphones may be used in the embodiments. It is to be understood that the group of microphones 110 are shown using a dotted line in FIG. 1 because the group of microphones 110 is not necessarily a part of the apparatus 100. In other words, the group of microphones 110 may be part of a mobile device or some other device into which the apparatus 100 is incorporated. In that case, the apparatus 100 is operatively coupled to the group of microphones 110, which are located within the mobile device, via a suitable communication bus or suitable connectors, etc., such that the group of microphones 110 are operatively coupled to the microphone configuration logic 120.

[0025] The microphone configuration logic 120 may include various front end processing, such as, but not limited to, signal amplification, analog-to-digital conversion/digital audio sampling, echo cancellation, etc., which may be applied to the microphone M1, M2, M3 outputs prior to performing additional, less power efficient signal processing such as noise suppression. The microphone configuration logic 120 may also include switch logic operatively coupled to the group of microphones 110 and operative to respond to control signals to turn each of microphones M1, M2 or M3 on or off so as to save power consumption by not using the front end processing of the microphone configuration logic 120 for those microphones that are turned off. Additionally, in some embodiments, the microphone configuration logic 120 may be operative to receive control signals from other components of the apparatus 100 to adjust front end processing parameters such as, for example, amplifier gain.

[0026] The microphone configuration logic 120 is operatively coupled to a history buffer 130, to provide the three microphone outputs M1, M2 and M3 to the history buffer 130. Microphone configuration logic 120 is also operatively coupled to an energy estimator 140 and provides a single microphone output M3 to the energy estimator 140. The energy estimator 140 is operatively coupled to the history buffer 130 and to a voice activity detector 150. The energy estimator 140 provides a control signal 115 to the history buffer 130, a control signal 117 to the voice activity detector 150 and a control signal 121 to the microphone configuration logic 120.

[0027] The voice activity detector 150 is also operatively coupled to the microphone configuration logic 120 to receive the microphone M3 output and to provide a control signal 123 to microphone configuration logic 120. The voice activity detector 150 is further operatively coupled to a signal-to-noise ratio (SNR) estimator 160 and provides a control signal

119. The signal-to-noise ratio (SNR) estimator 160 is operatively coupled to the history buffer 130, a noise type classifier 170, a noise suppressor algorithms selector 180, and a switch 195. In the various embodiments, the various signal processing components such as the voice activity detector 150, SNR estimator 160, noise type classifier 170, noise suppressor algorithms selector 180 and noise suppressor 190 are kept in a deactivated state until needed and are progressively activated according to various decisions which may also be made progressively. Likewise, activated signal components are progressively deactivated when no longer needed in accordance with the embodiments.

[0028] The SNR estimator 160 receives a buffered voice signal 113 from the history buffer 130 and provides control signal 127 to the switch 195, control signal 129 to noise type classifier 170, and control signal 135 to the noise suppressor algorithms selector 180. The noise type classifier 170 is operatively coupled to the history buffer 130, the SNR estimator 160 and the noise suppressor algorithms selector 180.

[0029] The noise type classifier 170 receives a buffered voice signal 111 from the history buffer 130 and provides a control signal 131 to the noise suppressor algorithms selector 180. The noise suppressor algorithms selector 180 is operatively coupled to the SNR estimator 160, the noise type classifier 170, the microphone configuration logic 120, a noise suppressor 190 and system memory 107. The noise suppressor algorithms selector 180 provides a control signal 125 to the microphone configuration logic 120 and a control signal 137 to a noise suppressor 190. The noise suppressor algorithms selector 180 is also operatively coupled to system memory 107 by a read-write connection 139.

[0030] The noise suppressor 190 receives the buffered voice signal 111 from the history buffer 130 and provides a noise suppressed voice signal 133 to the switch 195. The noise suppressor 190 may also be operatively coupled to system memory 107 by a read-write connection 143 in some embodiments. The switch 195 is operatively coupled to the noise suppressor 190 and to automatic gain control (AGC) 105, and provides voice signal 141 to the AGC 105. Voice command recognition logic 101 is operatively coupled to AGC 105 and to the system control 103, which may be any type of voice controllable system control depending on the mobile device such as, but not limited to, a voice controlled dialer of a mobile telephone, a video recorder system control, an application control of a mobile telephone, smartphone, tablet, laptop, etc., or any other type of voice controllable system control. The AGC 105 adjusts the voice signal 141 received from the switch 195 and provides a gain adjusted voice signal 145 to the voice command recognition logic 101. The voice command recognition logic 101 sends a control signal 147 to the system control 103 in response to detected command words or command phrases received on the voice signal 145. In some embodiments, a transceiver 197 may also be present and may be operatively coupled to receive either the gain adjusted voice signal 145 as shown, or to receive the voice signal 141. The transceiver 197 may be a wireless transceiver for wireless communication using any wireless technology and may utilize the received voice signal as an uplink (i.e. send) transmission portion of a wireless duplex communication channel in embodiments where the apparatus 100 is used in a mobile telephone or smartphone, or etc. In alternative embodiments, either the gain adjusted voice signal 145 or the voice signal 141 may also be provided to a transceiver external to the apparatus 100 using appropriate con-

nectivity between the apparatus 100 and a device into which the apparatus 100 is incorporated. In some embodiments, the transceiver 197 may be used to transmit voice commands to a remote voice command recognition system.

[0031] The system memory 107 is a non-volatile, non-transitory memory, and may be accessible by other components of the apparatus 100 for various settings, stored applications, etc. In some embodiments system memory 107 may store a database of noise suppression algorithms 109, which may be accessed by noise suppressor algorithms selector 180, over read-write connection 139. In some embodiments, the noise suppressor 190 access system memory 107 over read-write connection 143 and may retrieve selected noise suppression algorithms from the database of noise suppression algorithms 109 for execution.

[0032] The switch 195 is operative to respond to the control signal 127 from the SNR estimator 160, to switch its output voice signal 141 between the buffered voice signal 111 and the noise suppressor 190 noise suppressed voice signal 133. In other words, switch 195 operates as a changeover switch. The output voice signal 141 from switch 195 is provided to the AGC 105.

[0033] The disclosed embodiments employ voice activity detector 150 to distinguish voice activity from noise and accordingly enable the voice command recognition logic 101 and noise reduction as needed to improve voice recognition performance. The embodiments also utilize a low power noise estimator, SNR estimator 160, to determine when to enable or disable noise reduction thereby saving battery power. For example, under low noise conditions, the noise reduction can be disabled accordingly. Also, some microphones may be turned off during low noise conditions which also conserves battery power.

[0034] Various actions may be triggered or invoked in the embodiments based on voice activity or other criteria that progressively ramp up the application of signal processing requiring increased power consumption. For example, the voice activity detector 150 may trigger operation of noise suppressor 190 or may send control signal 123 to the microphone configuration logic 120 to increase front end processing gain, rather than invoke the noise suppressor 190, initially for low noise conditions.

[0035] For a high noise environment, dual-microphone noise reduction may be enabled. For low noise environments, a single microphone may be used, and the energy estimator 140 may create a long term energy base line from which rapid deviations will trigger the noise suppressor 190 and voice activity detector (VAD) 150 to analyze the voice signal and to decide when noise reduction should be applied. For example, an absolute ambient noise measurement may be used to decide if noise reduction should be applied and, if so, the type of noise reduction best suited for the condition. That is, because the noise suppressor algorithms selected will impact power consumption, selectively running or not running certain noise suppressor algorithms serves to minimize battery power consumption.

[0036] Thus, the energy estimator 140 is operative to detect deviations from a baseline that may be an indicator of voice being present in a received audio signal, received, for example, from microphone M3. If such deviations are detected, the energy estimator 140 may send control signal 117 to activate VAD 150 to determine if voice is actually present in the received audio signal.

[0037] An example method of operation of the apparatus 100 may be understood in view of the flowchart of FIG. 2. The method of operation begins in operation block 201 which represents a default state in which the microphone configuration logic 120 is controlled to use a single microphone configuration in order to conserve battery power. Any front end processing of the microphone configuration logic 120 for other microphones of the group of microphones 110 is therefore turned off. In operation block 203 the energy estimator 140 determines an energy baseline. The energy estimator 140 first calculates the signal level and long term power estimates, and short-term deviation from the long-term baseline. Short-term deviations exceeding a threshold invoke powering multiple microphones and buffering the signals.

[0038] Specifically, in decision block 205, the energy estimator 140 monitors the audio output from one microphone such as microphone M3 and looks for changes in the audio signal energy level. If an observed short-term deviation exceeds the threshold in decision block 205, the energy estimator 140 sends control signal 121 to the microphone configuration logic 120 to turn on at least one additional microphone as shown in operation block 207. In operation block 213, the energy estimator 140 also sends control signal 115 to history buffer 130 to invoke buffering of audio signals from the activated microphones since the buffered audio may need to have noise suppression applied in operation block 229. Also, in operation block 209, energy estimator 140 sends control signal 117 to VAD 150 to activate VAD 150 to determine if speech is present in the M3 audio signal. If the observed short-term deviation observed by the energy estimator 140 does not exceed the threshold in decision block 205, the energy estimator 140 continues to monitor the single microphone as in operation block 201. In other words, the energy estimator 140 operates to monitor an audio signal from at least one of the microphones while other signal processing components remain deactivated. A deactivated signal processing component is one that is powered down or placed in a low power mode such as a sleep state where the signal processing component operates with either no power consumption or with reduced power consumption. The signal processing component is therefore activated when it is either powered up or is awakened from a low power mode such as a sleep state.

[0039] In decision block 211, if the VAD 150 does not detect speech, the VAD 150 sends control signal 123 to the microphone configuration logic 120 and returns the system to a lower power state. For example, in operation block 231, the control signal 123 may turn off any additional microphones so that only a single microphone is used. If voice (i.e. speech activity) is detected in decision block 211, then VAD 150 sends control signal 119 to activate SNR estimator 160. In operation block 215, the SNR estimator 160 proceeds to estimate short-term signal-to-noise ratio and signal levels in order to determine if de-noising is needed.

[0040] If noise reduction is not needed in decision block 217, the SNR estimator 160 may send control signal 127 to the switch 195 to maintain the apparatus 100 in a low power state, i.e. bypassing and not using the noise suppressor 190. The apparatus 100 may also be returned to a single microphone mode of operation. For example, the noise suppressor algorithms selector 180 may send control signal 125 to the microphone configuration logic 120 to switch off any additional microphones. In operation block 219, the voice signal 141 is provided to the AGC 105 and is gained up to obtain the

level required and the gain adjusted voice signal **145** is sent to the voice command recognition logic **101**. In operation block **221**, the voice command recognition logic **101** and, if command words or command phrases are detected, may send control signal **147** to the system control **103**. The method of operation then ends. If noise reduction is determined to be necessary by the SNR estimator **160** in decision block **217**, then the SNR estimator **160** sends control signal **129** to activate noise type classifier **170** as shown in operation block **223**.

[0041] In operation block **223**, the noise type classifier **170** receives the buffered voice signal **111**, and may also receive signal-to-noise ratio information from SNR estimator **160** via control signal **129**. The noise type classifier **170** assigns a noise type and sends the noise type information by control signal **131** to noise suppressor algorithms selector **180**. The noise suppressor algorithms selector **180** may also receive information from SNR estimator **160** via control signal **135**. In operation block **225**, the noise suppressor algorithms selector **180** proceeds to select an appropriate noise suppressor algorithm for the observed conditions (i.e. observed SNR and noise type). This may be accomplished, in some embodiments, by accessing system memory **107** over read-write connection **139**. The system memory **107** may store the database of noise suppression algorithms **109** and any other useful information such as an associated memory table that can be used to compare observed SNR and noise types to select a suitable noise suppression algorithm. The noise suppressor algorithms selector **180** may then send control signal **137** to activate noise suppressor **190** and to provide a pointer to the location in system memory **107** of the selected noise suppression algorithm. In operation block **227**, the noise suppressor algorithms selector **180** may also send control signal **125** to the microphone configuration logic to make any adjustments that might be needed in relation to the selected noise suppressor algorithm.

[0042] In operation block **229**, the noise suppressor **190** may access system memory **107** and the database of noise suppression algorithms **109** over read-write connection **143** to access the selected noise suppression algorithm and execute it accordingly. The SNR estimator **160** will also send control signal **127** to switch **195** to switch to receive the noise suppressed voice signal **133** output from noise suppressor **190**, rather than the buffered voice signal **111**. Instead, the noise suppressor **190** receives the buffered voice signal **111**, applies the selected noise suppression algorithm and provides the noise suppressed voice signal **133** to switch **195**. The method of operation then again proceeds to operation block **219** where the voice signal **141** is provided to the AGC **105** and is gained up to obtain the level required and the gain adjusted voice signal **145** is sent to the voice command recognition logic **101**. In operation block **221**, the voice command recognition logic **101** operates on the gain adjusted voice signal **145** and the method of operation ends as shown. The apparatus **100** may then return to single microphone operation and the method of operation beginning at operation block **201** may continue.

[0043] Initially, in the embodiments, a noise suppressor algorithm is invoked based on the attempt to determine the type of noise present in the environment, based on the noise type, and signal to noise ratio. As the noise conditions worsen, different noise algorithms can be used, with progressively increased complexity and power consumption cost. As discussed above with respect to decision block **211**, the system

returns to low power state after a negative VAD **150** decision or, in some embodiments after some time-out period.

[0044] In another embodiment, the apparatus **100** may run a continuous single microphone powered, long-term noise estimator/classifier which can store a set of noise estimates to be used by the noise reduction system to aid speed up convergence. In yet another embodiment, a continuously run VAD may be employed to look for speech activity. In both embodiments, the apparatus will remain in an elevated power state returning from voice recognition invocation into VAD estimation.

[0045] It is to be understood that the various components, circuitry, devices etc. described with respect to FIG. **1** including, but not limited to, those described using the term "logic," such as the microphone configuration logic **120**, history buffer **130**, energy estimator **140**, VAD **150**, SNR estimator **160**, noise type classifier **170**, noise suppressor algorithms selector **180**, noise suppressor **190**, switch **195**, AGC **105**, voice command recognition logic **101**, or system control **103** may be implemented in various ways such as by software and/or firmware executing on one or more programmable processors such as a central processing unit (CPU) or the like, or by ASICs, DSPs, FPGAs, hardwired circuitry (logic circuitry), or any combinations thereof.

[0046] Also, it is to be understood that the various "control signals" described herein with respect to FIG. **1** and the various aforementioned components, may be implemented in various ways such as using application programming interfaces (APIs) between the various components. Therefore, in some embodiments, components may be operatively coupled using APIs rather than a hardware communication bus if such components are implemented as by software and/or firmware executing on one or more programmable processors. For example, the noise suppressor algorithms selector **180** and the noise suppressor **190** may be software and/or firmware executing on a single processor and may communicate and interact with each other using APIs.

[0047] Additionally, operations involving the system memory **107** may be implemented using pointers where the components such as, but not limited to, the noise suppressor algorithms selector **180** or the noise suppressor **190**, access the system memory **107** as directed by control signals which may include pointers to memory locations or database access commands that access the database of noise suppression algorithms **109**. In other words, such operations may be accomplished in the various embodiments using application programming interfaces (APIs).

[0048] Further methods of operation of various embodiments are illustrated by the flowcharts of FIG. **3** and FIG. **4**. FIG. **3** is a flow chart showing a method of operation related to voice signal detection in accordance with various embodiments. In operation block **301**, an apparatus uses a microphone signal level as a measure to determine if pre-processing is needed. In operation block **303**, the apparatus runs a detector for energy deviations from a long term base-line and invokes VAD/noise estimators to make decisions as to when voice recognition logic should operate. In operation block **305**, the apparatus detects the need for signal conditioning based on a low-power noise estimator (i.e. by running the noise estimator only). In operation block **307**, the apparatus uses a VAD to determine voice activity from noise and to determine to whether or not to run noise suppression, or voice recognition, and runs one or the other only when needed. In operation block **309**, the apparatus will classify the noise

type, and based on noise type, will invoke appropriate noise suppression or other appropriate signal conditioning.

[0049] FIG. 4 is a flow chart showing a method of operation related to selection of signal processing in accordance with various embodiments. In operation block 401, the apparatus determines which microphones are not needed (as well as any associated circuitry such as amplifiers, A/D converters etc.) and turns off the microphones (and any associated circuitry) accordingly. In operation block 403, the apparatus uses a single microphone for continuously running triggers/estimators. In operation block 405, the apparatus uses an ultra-low-power microphone for monitoring only (or uses lower power mode for one of the microphones). In operation block 407, the apparatus stores data in a history buffer, and when triggered processes only data in the history buffer, rather than continuously. That is, the history buffer maintains an audio signal of interest while decisions are made as to whether voice is present in the audio signal and, subsequently, whether further signal processing components should be invoked such as noise suppression. If further signal processing components such as the noise suppressor are not required, the buffered audio signal may be sent directly to the voice command recognition logic 101. In operation block 409, the apparatus uses no noise suppression (in quiet conditions), single-microphone noise suppression (for example in favorable SNR and noise types), multiple-microphone noise suppression as per conditions observed and when needed only. In operation block 411, the apparatus determines signal level and SNR dependency, maximizes gain in high SNR conditions (i.e. if favorable conditions exist apply gain to boost signal, rather than de-noise signal). In operation block 413, the apparatus uses voice recognition specially trained with power-efficient noise-reduction pre-processing algorithm, and runs the power efficient noise reduction front end on the portable (i.e. a mobile device in which the apparatus is incorporated). In operation block 415, the apparatus uses long-term noise estimates to configure apparatus components such as voice recognition and signal conditioning components, and uses the short-term estimate to select optimal configurations and switch between those.

[0050] The flowcharts of FIG. 5 and FIG. 6 provide methods of operation for the various embodiments described above. In FIG. 5, operation block 501, an audio signal energy level is monitored while having other signal processing components deactivated. In operation block 503, at least one of the other signal processing components is activated in response to a detected change in the audio signal energy level. For example, if the energy level changes, this may be an indication that a device operator is speaking and attempting to command the device. In response, a VAD may be activated as the at least one other signal processing component in some embodiments. If the VAD detects the presence of voice in the audio signal, further signal processing components, such as a noise suppressor, may be activated. In another embodiment, a noise estimator may be activated initially using the assumption that voice is present in the audio signal.

[0051] The flowchart of FIG. 6 provides a method of operation where a VAD is activated in response to changes in the audio signal level as shown in operation block 601. Other signal processing components are deactivated initially. In operation block 603, if voice is detected by the VAD, other signal processing components are activated in order to analyze the audio signal and determine if noise suppression should be applied or not. Noise suppression is then either

applied, or not applied, accordingly. In operation block 605, various audio signal processing components are either activated or deactivated as audio signal conditions change or when voice is no longer detected. For example, the apparatus may be returned from a multi-microphone configuration to a single, low-power microphone configuration and noise suppressors, etc. may be deactivated.

[0052] While various embodiments have been illustrated and described, it is to be understood that the invention is not so limited. Numerous modifications, changes, variations, substitutions and equivalents will occur to those skilled in the art without departing from the scope of the present invention as defined by the appended claims.

What is claimed is:

1. A method comprising:
 - monitoring an audio signal energy level with a plurality of signal processing components deactivated; and
 - activating at least one signal processing component of the plurality of signal processing components in response to a detected change in the audio signal energy level.
2. The method of claim 1, wherein activating at least one signal processing component comprises:
 - activating and running a voice activity detector on the audio signal in response to the detected change in the audio energy level, the voice activity detector being one of the plurality of signal processing components.
3. The method of claim 2, further comprising:
 - activating and running a noise estimator in response to voice being detected in the audio signal by the voice activity detector.
4. The method of claim 3, further comprising:
 - determining, by the noise estimator, that noise suppression is required for the audio signal; and
 - activating and running a noise suppressor on the audio signal in response to the noise estimator determination.
5. The method of claim 3, further comprising:
 - activating and running a noise type classifier to determine a noise type based on information received from the noise estimator; and
 - selecting a noise suppressor algorithm based on the determined noise type.
6. The method of claim 3, further comprising:
 - determining, by the noise estimator, that noise suppression is not required for the audio signal; and
 - performing voice recognition on the audio signal without activating a noise suppressor.
7. The method of claim 1, further comprising:
 - activating at least one additional microphone to receive the audio signal in response to the detected change in the audio signal energy level.
8. The method of claim 7, further comprising:
 - deactivating the at least one additional microphone and returning to a single microphone configuration in response to voice not being detected in the audio signal by a voice activity detector or a second detected change in the audio signal energy level.
9. The method of claim 1, further comprising:
 - calculating, by an energy estimator, a long term energy baseline and a short term deviation wherein monitoring the audio signal energy level is performed by the energy estimator.
10. The method of claim 9, further comprising:
 - buffering the audio signal in response to a detected short term deviation.

- 11.** An apparatus comprising:
a noise suppressor;
a voice activity detector; and
an energy estimator, operatively coupled to the voice activity detector, the energy estimator operative to monitor an audio signal energy level with at least the noise suppressor and the voice activity detector deactivated and to activate at least the voice activity detector in response to a detected change in the audio signal energy level.
- 12.** The apparatus of claim **11**, further comprising:
a noise estimator, operatively coupled to the voice activity detector, wherein the voice activity detector is operative to activate the noise estimator in response to voice being detected in the audio signal.
- 13.** The apparatus of claim **12**, further comprising:
a buffer, operatively coupled to the energy estimator, the buffer operative to receive a buffer control signal from the energy estimator and to buffer the audio signal in response to the buffer control signal, the energy estimator operative to send the buffer control signal in response to the detected change in the audio signal energy level.
- 14.** The apparatus of claim **13**, further comprising:
a switch, operatively coupled to the noise suppressor and to the noise estimator to receive a switch control signal, the switch operative to change over between a noise suppressed audio signal output from the noise suppressor and a buffered audio signal output from the buffer, according to the switch control signal; and
wherein the noise estimator is operative to send the switch control signal.
- 15.** The apparatus of claim **14**, further comprising:
a noise suppressor algorithms selector, operatively coupled to the noise estimator and to the noise suppressor, the noise suppressor algorithms selector operative to activate and run the noise suppressor in response to a noise estimator control signal sent when the noise estimator determines that noise suppression is required.

- 16.** The apparatus of claim **15**, further comprising:
a noise type classifier, operatively coupled to the noise estimator and to the noise suppressor algorithms selector, the noise type classifier operative to activate and run in response to a control signal from the noise estimator, and operative to determine noise type based on information received from the noise estimator.
- 17.** The apparatus of claim **16**, wherein the noise suppressor algorithms selector is further operative to select a noise suppressor algorithm based on the noise type determined by the noise type classifier.
- 18.** The apparatus of claim **14**, where the noise estimator is further operative to determine that noise suppression is not required and send the switch control signal to change over from the noise suppressed audio signal output from the noise suppressor to the buffered audio signal output from the buffer.
- 19.** The apparatus of claim **11**, further comprising:
a plurality of microphones; and
microphone configuration logic operative to turn each microphone on or off; and
wherein the energy estimator is further operative to control the microphone configuration logic to turn on at least one additional microphone in response to the detected change in the audio signal energy level.
- 20.** The apparatus of claim **19**, wherein the voice activity detector is operative to deactivate the at least one additional microphone and return to a single microphone configuration in response to voice not being detected in the audio signal by the voice activity detector.
- 21.** The apparatus of claim **14**, further comprising:
voice command recognition logic, having an input operatively coupled to the switch.
- 22.** The apparatus of claim **21**, further comprising:
a transceiver having an input operatively coupled to the switch.

* * * * *