



US00D959250S

(12) **United States Design Patent**
Stahl et al.

(10) **Patent No.:** **US D959,250 S**
(45) **Date of Patent:** **** Aug. 2, 2022**

- (54) **SLIDE CLIP**
- (71) Applicant: **Clarkwestern Dietrich Building Systems LLC**, West Chester, OH (US)
- (72) Inventors: **Gregg Allan Stahl**, Lebanon, OH (US); **Brett Daniel Hironimus**, Beaver Falls, PA (US)
- (**) Term: **15 Years**
- (21) Appl. No.: **29/743,533**
- (22) Filed: **Jul. 22, 2020**
- (51) **LOC (13) Cl.** **08-05**
- (52) **U.S. Cl.**
USPC **D8/382; D25/199**
- (58) **Field of Classification Search**
USPC D8/349, 354, 355, 371, 373, 380, 381, D8/382; D25/199
CPC E04B 2/768; E04B 2/789; E04B 2/828; E04B 2/90; E04B 1/2403; E04B 1/40; E04B 2001/2415; E04B 2001/2439; E04B 2001/2448; E04B 2001/2457; E04B 2001/405
See application file for complete search history.

| | | | |
|-----------|---|---------|----------------------|
| 3,940,900 | A | 3/1976 | Russo |
| 4,022,415 | A | 5/1977 | Roderick |
| 4,035,093 | A | 7/1977 | Redshaw |
| 4,060,905 | A | 12/1977 | Light |
| 4,097,012 | A | 6/1978 | McIntyre |
| 4,131,221 | A | 12/1978 | Yeager |
| 4,194,333 | A | 3/1980 | Paton |
| 4,251,969 | A | 2/1981 | Bains |
| 4,263,764 | A | 4/1981 | Wendt |
| 4,321,776 | A | 3/1982 | Delight |
| 4,363,459 | A | 12/1982 | Holzer |
| 4,409,765 | A | 10/1983 | Pall |
| D272,719 | S | 2/1984 | Skjaeveland |
| 4,433,524 | A | 2/1984 | Matson |
| 4,464,074 | A | 8/1984 | Green et al. |
| 4,709,517 | A | 12/1987 | Mitchell |
| 4,723,747 | A | 2/1988 | Karp et al. |
| 4,765,108 | A | 8/1988 | Lapish |
| 4,796,403 | A | 1/1989 | Fulton |
| 4,815,734 | A | 3/1989 | Verhulst |
| 4,835,935 | A | 6/1989 | Murphy |
| 4,899,510 | A | 2/1990 | Propst |
| 4,918,893 | A | 4/1990 | Vandenbroucke et al. |
| 4,932,173 | A | 6/1990 | Commis |
| 4,949,929 | A | 8/1990 | Kesselman et al. |
| D310,478 | S | 9/1990 | Lang |
| 4,955,172 | A | 9/1990 | Pierson |
| D312,962 | S | 12/1990 | Overton |
| 5,004,369 | A | 4/1991 | Young |
| 5,009,557 | A | 4/1991 | Dessirier |
| 5,027,494 | A | 7/1991 | Martin |
| 5,040,345 | A | 8/1991 | Gilmour |
| 5,090,171 | A | 2/1992 | Kano |
| 5,118,060 | A | 6/1992 | Spronken |
| 5,152,117 | A | 10/1992 | Wynar |
| 5,169,062 | A | 12/1992 | Baker |
| 5,201,787 | A | 4/1993 | LaLonde et al. |
| 5,216,858 | A | 6/1993 | Gilmour |
| 5,217,317 | A | 6/1993 | Young |
| D339,735 | S | 9/1993 | Brennan |
| 5,271,586 | A | 12/1993 | Schmidt |
| 5,313,752 | A | 5/1994 | Hatzinikolas |
| 5,375,382 | A | 12/1994 | Weidlinger |
| 5,392,579 | A | 2/1995 | Champagne |
| 5,392,581 | A | 2/1995 | Hatzinikolas |
| 5,408,724 | A | 4/1995 | Mullet |
| D360,571 | S | 7/1995 | Perry |
| 5,454,203 | A | 10/1995 | Turner |
| 5,457,928 | A | 10/1995 | Sahnazarian |
| 5,467,566 | A | 11/1995 | Swartz et al. |
| 5,529,273 | A | 6/1996 | Benthin |
| D371,506 | S | 7/1996 | Nofziger |
| D373,902 | S | 9/1996 | Wang |

(56) **References Cited**
U.S. PATENT DOCUMENTS

| | | | |
|-----------|---|---------|--------------|
| 1,188,959 | A | 6/1916 | McAlarney |
| 1,400,007 | A | 12/1921 | Sparks |
| 1,486,509 | A | 3/1924 | Whittaker |
| 1,600,794 | A | 9/1926 | Brown |
| 2,058,386 | A | 10/1936 | Parsons |
| 2,235,761 | A | 3/1941 | Goldsmith |
| 2,258,574 | A | 10/1941 | Leary |
| 2,365,478 | A | 12/1944 | La Grotta |
| 3,003,600 | A | 10/1961 | Mackenzie |
| 3,113,358 | A | 12/1963 | Zell |
| 3,350,830 | A | 11/1967 | Smith et al. |
| 3,353,312 | A | 11/1967 | Storch |
| 3,445,977 | A | 5/1969 | Latiano |
| 3,490,797 | A | 1/1970 | Platte |
| 3,753,325 | A | 8/1973 | Stanley |
| 3,798,865 | A | 3/1974 | Curtis |

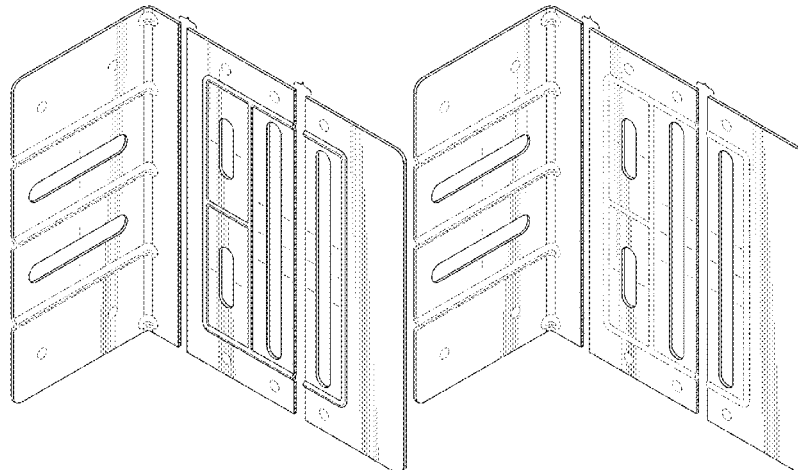

US D959,250 S

| | | | | | | |
|----------------|---------|--------------------|-----------------|---------|---------------------|-------------|
| 5,554,392 A | 9/1996 | Gray | 7,614,195 B2 | 11/2009 | Platt et al. | |
| D375,038 S | 10/1996 | Trevorrow | D608,183 S | 1/2010 | Meyer | |
| 5,572,844 A | 11/1996 | Stackenwalt et al. | 7,658,356 B1 | 2/2010 | Nehls | |
| 5,611,179 A | 3/1997 | Leek | D621,692 S | 8/2010 | Clarke | |
| 5,640,823 A | 6/1997 | Bergeron et al. | D628,539 S | 12/2010 | Tezak et al. | |
| 5,664,392 A | 9/1997 | Mucha | D630,346 S | 1/2011 | Horta | |
| 5,664,754 A | 9/1997 | Gaenslen | 7,902,457 B2 | 3/2011 | Johnson | |
| 5,671,580 A | 9/1997 | Chou | 7,918,054 B2 | 4/2011 | Grafton et al. | |
| 5,678,797 A | 10/1997 | Gogan | D638,286 S * | 5/2011 | Tedesco | D8/394 |
| 5,685,121 A | 11/1997 | DeFrancesco | D640,916 S * | 7/2011 | Sias | D8/382 |
| 5,718,533 A | 2/1998 | Mullet | D644,503 S * | 9/2011 | Crane | D8/382 |
| 5,720,571 A | 2/1998 | Frobosilo et al. | D649,016 S | 11/2011 | Rasmussen | |
| 5,743,063 A | 4/1998 | Boozer | D652,951 S | 1/2012 | Crane et al. | |
| 5,779,206 A | 7/1998 | Harris et al. | 8,091,316 B2 | 1/2012 | Beck et al. | |
| D398,820 S | 9/1998 | Cougar | 8,181,419 B1 | 5/2012 | diGirolamo | |
| 5,810,303 A | 9/1998 | Bourassa et al. | D663,020 S | 7/2012 | Purnell | |
| D400,081 S | 10/1998 | Ibaragi | D663,190 S | 7/2012 | Mota et al. | |
| 5,836,133 A | 11/1998 | Bergeron et al. | 8,234,826 B1 | 8/2012 | Proffitt, Jr. | |
| 5,846,018 A | 12/1998 | Frobosilo et al. | 8,240,103 B2 | 8/2012 | Riepe | |
| 5,857,306 A | 1/1999 | Pellock | D667,288 S * | 9/2012 | Preda | D8/354 |
| 5,876,006 A | 3/1999 | Sharp et al. | D667,289 S * | 9/2012 | Preda | D8/354 |
| D408,266 S | 4/1999 | Santiago | 8,272,806 B2 | 9/2012 | Mogar et al. | |
| 5,904,023 A | 5/1999 | diGirolamo et al. | 8,281,541 B2 | 10/2012 | Lucey et al. | |
| 5,906,080 A | 5/1999 | diGirolamo et al. | 8,347,581 B2 | 1/2013 | Doerr et al. | |
| 5,924,259 A | 7/1999 | Marousek | 8,387,321 B2 | 3/2013 | diGirolamo et al. | |
| 5,937,605 A | 8/1999 | Wendt | D684,033 S | 6/2013 | Preda | |
| D414,398 S | 9/1999 | Benz et al. | 8,453,407 B2 | 6/2013 | Tedesco et al. | |
| 5,956,916 A | 9/1999 | Liss | 8,511,032 B2 | 8/2013 | Abdel-Rahman et al. | |
| 6,009,681 A | 1/2000 | Kozloff | 8,544,229 B2 | 10/2013 | Kilgore et al. | |
| D420,565 S | 2/2000 | Griffiths | 8,555,592 B2 | 10/2013 | Daudet et al. | |
| 6,018,923 A | 2/2000 | Wendt | D692,746 S | 11/2013 | Lawson et al. | |
| D422,886 S * | 4/2000 | Shea | 8,590,257 B2 | 11/2013 | Yurko, Sr. | |
| 6,058,668 A | 5/2000 | Herren | 8,615,942 B2 | 12/2013 | LaFreniere | |
| 6,088,982 A | 7/2000 | Hiesberger | 8,615,948 B2 | 12/2013 | Underkofler et al. | |
| D432,901 S | 10/2000 | McDonald | 8,683,770 B2 | 4/2014 | diGirolamo et al. | |
| 6,138,425 A | 10/2000 | Wendt | 8,713,872 B2 | 5/2014 | Rempel | |
| 6,199,929 B1 | 3/2001 | Hansch | 8,763,336 B2 | 7/2014 | Gulbrandsen et al. | |
| 6,213,679 B1 | 4/2001 | Frobosilo et al. | 8,769,887 B2 | 7/2014 | Proffitt, Jr. | |
| D442,471 S * | 5/2001 | Willett | 8,800,232 B1 | 8/2014 | Keenan | |
| 6,250,041 B1 | 6/2001 | Seccombe | 8,813,457 B2 | 8/2014 | Underkofler et al. | |
| D451,786 S | 12/2001 | Wyatt et al. | 8,833,008 B2 | 9/2014 | Truckner | |
| 6,427,416 B1 | 8/2002 | Rassel | 8,950,151 B2 | 2/2015 | Strickland et al. | |
| 6,508,447 B1 | 1/2003 | Catani et al. | 8,973,333 B2 | 3/2015 | Sugihara et al. | |
| 6,523,322 B1 | 2/2003 | Michalski et al. | 8,998,137 B2 | 4/2015 | Braeutigam et al. | |
| 6,585,448 B2 | 7/2003 | Grossman | 9,010,070 B2 | 4/2015 | Darr, III et al. | |
| 6,609,344 B2 | 8/2003 | Saldana | D729,611 S | 5/2015 | Schmidt | |
| 6,612,087 B2 | 9/2003 | diGirolamo et al. | D730,545 S | 5/2015 | Stauffer et al. | |
| D482,261 S | 11/2003 | Kobayashi | 9,032,681 B1 | 5/2015 | Brady | |
| D482,598 S | 11/2003 | Brass | D731,876 S * | 6/2015 | Di Stefano | D8/363 |
| 6,688,069 B2 | 2/2004 | Zadeh | D732,708 S | 6/2015 | Stauffer et al. | |
| 6,741,703 B1 | 5/2004 | Clour | 9,045,892 B2 | 6/2015 | Smith et al. | |
| 6,792,733 B2 | 9/2004 | Wheeler et al. | 9,091,056 B2 | 7/2015 | Stauffer et al. | |
| 6,871,470 B1 | 3/2005 | Stover | 9,140,000 B1 | 9/2015 | Brady | |
| D517,402 S | 3/2006 | Cairns | D740,108 S | 10/2015 | Di Stefano | |
| 7,021,021 B2 | 4/2006 | Saldana | 9,234,344 B2 | 1/2016 | Hatzinikolas | |
| 7,065,932 B2 | 6/2006 | Roesset et al. | 9,255,403 B1 | 2/2016 | Lehane et al. | |
| D527,986 S | 9/2006 | Johnson | D751,222 S | 3/2016 | Darr, III et al. | |
| 7,104,024 B1 | 9/2006 | di Girolamo et al. | D751,733 S | 3/2016 | Darr, III et al. | |
| D530,191 S | 10/2006 | Taylor | 9,290,928 B2 | 3/2016 | Klein | |
| 7,127,862 B2 | 10/2006 | Saldana | D753,638 S | 4/2016 | Tatem et al. | |
| D532,290 S | 11/2006 | David | D766,701 S | 9/2016 | Snell | |
| D533,445 S | 12/2006 | Janzen | D769,698 S | 10/2016 | Oltrogge | |
| D536,954 S | 2/2007 | Sjoberg | D774,874 S | 12/2016 | Wentzel et al. | |
| 7,174,690 B2 | 2/2007 | Zadeh | 9,663,948 B2 | 5/2017 | Lehane et al. | |
| 7,178,304 B2 | 2/2007 | Brady | 9,677,269 B2 | 6/2017 | Wright | |
| D543,834 S | 6/2007 | Worthy | D810,546 S * | 2/2018 | Shaw | D8/363 |
| 7,293,393 B2 | 11/2007 | Kelly et al. | 9,896,840 B2 | 2/2018 | Ting | |
| 7,299,593 B1 * | 11/2007 | diGirolamo | 9,909,312 B2 | 3/2018 | Lehane et al. | |
| | | | D814,905 S * | 4/2018 | Ralph | D8/349 |
| 7,356,973 B2 | 4/2008 | Roesset et al. | D815,313 S * | 4/2018 | Ralph | D25/199 |
| D569,232 S | 5/2008 | Yoshida | D815,314 S * | 4/2018 | Ralph | D25/199 |
| D572,114 S | 7/2008 | Segovia | D815,315 S * | 4/2018 | Ralph | D25/199 |
| D576,473 S | 9/2008 | Cresswell | D815,316 S * | 4/2018 | Ralph | D25/199 |
| 7,478,508 B2 | 1/2009 | Peterson | D817,149 S * | 5/2018 | Ralph | D8/349 |
| D587,100 S | 2/2009 | Allsopp | 10,024,048 B2 | 7/2018 | Getz | |
| 7,503,150 B1 | 3/2009 | di Girolamo et al. | 10,132,341 B2 | 11/2018 | di Girolamo et al. | |
| 7,533,508 B1 * | 5/2009 | diGirolamo | 10,724,229 B2 * | 7/2020 | Daudet | E04B 1/2403 |
| | | | D906,788 S * | 1/2021 | Ochi | D8/354 |
| D595,114 S | 6/2009 | Hamilton | 10,961,704 B2 | 3/2021 | Daudet | |

| | | | | |
|--------------|-----|---------|---------------------|------------------------|
| D931,496 | S * | 9/2021 | Melin | D25/38.1 |
| D943,404 | S * | 2/2022 | Tran | D8/373 |
| 2002/0023405 | A1 | 2/2002 | Zadeh | |
| 2002/0062617 | A1 | 5/2002 | di Girolamo et al. | |
| 2005/0279901 | A1 | 12/2005 | McCoy et al. | |
| 2006/0026924 | A1 | 2/2006 | Madsen | |
| 2006/0032183 | A1 | 2/2006 | Peterson | |
| 2006/0096192 | A1 | 5/2006 | Daudet | |
| 2006/0196143 | A1* | 9/2006 | Roesset | E04C 3/12 52/712 |
| 2007/0089841 | A1 | 4/2007 | Rossato et al. | |
| 2008/0053034 | A1 | 3/2008 | Matechuk et al. | |
| 2008/0163581 | A1 | 7/2008 | Greth | |
| 2008/0258026 | A1 | 10/2008 | Smith et al. | |
| 2009/0113827 | A1 | 5/2009 | Stone et al. | |
| 2009/0193750 | A1 | 8/2009 | Klima | |
| 2010/0083606 | A1 | 4/2010 | Davis et al. | |
| 2010/0126103 | A1* | 5/2010 | diGirolamo | E04B 2/767 52/655.1 |
| 2011/0197541 | A1 | 8/2011 | Knoop | |
| 2011/0219720 | A1 | 9/2011 | Strickland et al. | |
| 2012/0247059 | A1* | 10/2012 | Daudet | E04B 1/2403 52/698 |
| 2013/0125400 | A1 | 5/2013 | Clapp et al. | |
| 2013/0139466 | A1 | 6/2013 | Abdel-Rahman et al. | |
| 2014/0290175 | A1 | 10/2014 | Klein | |
| 2014/0352249 | A1 | 12/2014 | Jankovec et al. | |
| 2015/0159369 | A1 | 6/2015 | Chen et al. | |
| 2015/0308098 | A1 | 10/2015 | Tessadori | |
| 2016/0333579 | A1 | 11/2016 | Stein | |
| 2017/0044787 | A1 | 2/2017 | di Girolamo et al. | |
| 2017/0204599 | A1 | 7/2017 | Daudet et al. | |
| 2017/0204600 | A1 | 7/2017 | Daudet et al. | |
| 2018/0066424 | A1* | 3/2018 | Daudet | E04B 2/768 |
| 2018/0066425 | A1* | 3/2018 | Ralph | E04B 1/2403 |
| 2018/0135293 | A1 | 5/2018 | Daudet | |
| 2018/0148920 | A1 | 5/2018 | Delfeld | |
| 2018/0266101 | A1* | 9/2018 | Haba | E04B 1/40 |
| 2022/0025637 | A1* | 1/2022 | Stahl | E04B 1/40 |

FOREIGN PATENT DOCUMENTS

| | | | |
|----|----------------|----|---------|
| CA | 2165643 | A1 | 6/1996 |
| CA | 2243897 | A1 | 2/1999 |
| CA | 2217076 | A1 | 4/1999 |
| CA | 2260554 | A1 | 7/1999 |
| CA | 2742742 | A1 | 3/2010 |
| CA | 2463747 | C | 1/2011 |
| CA | 2830677 | A1 | 10/2012 |
| CA | 2940128 | A1 | 10/2012 |
| CA | 2934777 | A1 | 7/2015 |
| CA | 2838361 | C | 4/2016 |
| CA | 162955 | S | 5/2016 |
| CA | 2784885 | C | 4/2017 |
| CN | 303539282 | | 1/2016 |
| EP | 1 070 904 | B1 | 2/2005 |
| EP | 2 093 335 | A2 | 8/2009 |
| EP | 2 093 336 | A2 | 8/2009 |
| EP | 1 770 840 | B1 | 11/2009 |
| JP | D 1330583 | | 5/2008 |
| WO | WO 00/07483 | A1 | 2/2000 |
| WO | WO 2007/115351 | A1 | 10/2007 |
| WO | WO 2010/009727 | A1 | 1/2010 |
| WO | WO 2010/092563 | A1 | 8/2010 |
| WO | WO 2014/004363 | A1 | 1/2014 |
| WO | WO 2014/193486 | A1 | 12/2014 |
| WO | WO 2015/003216 | A1 | 1/2015 |
| WO | WO 2015/101582 | A2 | 7/2015 |
| WO | WO 2016/028500 | A1 | 2/2016 |

OTHER PUBLICATIONS

ClarkDietrich FastClip YouTube <https://www.youtube.com/watch?v=XLbGZBs6Mwc> Mar. 28, 2014 (Year: 2014).*

ClarkDietrich FastClip Slide Clip Benefast <https://benefast.com/product/clarkdietrich-fastclip-slide-clip-14-gauge-5-1-2-x-1-1-2-x-4-1-2-inc-80-screws-fcsc-5-5-68-25-box/> Sep. 2020 (Year: 2020).*

Clamp L Shape Bracket, MiSumi, USA, 2012 Metric Catalog, p. 1-1552, downloaded from https://us.misumi-ec.com/pdf/fa/2012/pL_1551.pdf, 1 pg.

ClarkDietrich Drift FastClip Slide Clip, downloaded from <https://www.youtube.com/watch?v=c0v0plodJQ8>, posted Feb. 3, 2017, 1 pg.

Curtainwall Deflection Solutions, Super Stud Building Products, Inc., Brochure, 2001, 24 pgs.

Curtain Wall Brochure, The Steel Network, publication date unknown, Raleigh, North Carolina, 12 pgs.

DESC—Exterior Head-of-Wall Drift Clip, SCAFCO Steel Stud Company, Jun. 26, 2016, downloaded from <http://www.scafco.com/steel/products/deflection-clips/desc-exterior-head-of-wall-multi-drift-clip>, 2 pgs.

DISC—Interior Head-of-Wall Drift Clip, SCAFCO Steel Stud Company, Jun. 26, 2016, downloaded from <http://scafco.com/steel/products/deflection-clips/disc-interior-head-of-wall-multi-drift-clip>, 2pgs.

Double Bypass & Triple Bypass—Curtain Vertical Deflection Clips, SSDB & SSTB Series, Product Submittal Sheet, Super Stud Building Products, Inc., 2019, downloaded Oct. 27, 2020 from [https://www.buysuperstud.com/PDF/pdf/SuperStud%20Triple%20Bypass%20Vertical%20Deflection%20Clips%20\(SSTB\).pdf](https://www.buysuperstud.com/PDF/pdf/SuperStud%20Triple%20Bypass%20Vertical%20Deflection%20Clips%20(SSTB).pdf), 2 pgs.

DPLC2—Bypass Slab Drift Clip, SCAFCO Steel Stud Company, Jun. 16, 2016, downloaded from <http://www.scalco.com/steel/products/deflection-clips/dplc2-bypass-slab-drift-clip>, 2 pgs.

DPLC2—Bypass Slab Drift Clip, SCAFCO Steel Stud Company, 2000, downloaded Oct. 27, 2020 from <https://www.scafco.com/steel/products/deflection-clips/dplc2-bypass-slab-drift-clip/>, 4 pgs.

Drift FastClip™ Slide Clip (D-FCSC), Product Submittal Sheets, ClarkDietrich Building Systems, Sep. 2020, downloaded Oct. 23, 2020 from <https://www.clarkdietrich.com/products/drift-connections/drift-fastclip-slide-clip-d-fcsc#submittals>, 6 pgs.

Drift Head-of-Wall (DHOW), Product Submittal Sheets, ClarkDietrich Building Systems, Feb. 2019, downloaded Oct. 23, 2020 from <https://www.clarkdietrich.com/products/drift-connections/drift-head-wall-dhow#submittals>, 6 pgs.

Drift Rail (DR97) and Clip (DRC), Product Submittal Sheets, ClarkDietrich Building Systems, Sep. 2020, downloaded Oct. 23, 2020 from <https://www.clarkdietrich.com/products/drift-connections/drift-rail-dr97-and-clip-drc#submittals>, 6 pgs.

Drift-Clip Bypass Framing Connector, Tech Sheet, Simpson Strong-Tie Company, Inc., May 2016, 2 pgs.

DriftClip® DSLB, Bypass Slab, Tech Sheet, The Steel Network, Inc., Jul. 2017, downloaded Oct. 27, 2020 from <https://steelnetwork.com/Product/DriftClipDSLB>, 2 pgs.

DrifTrak® DTSL, Tech Sheet, The Steel Network, Inc. (TSN), 2012, downloaded Jul. 6, 2017 from <https://web.archive.org/web/20121008023139/http://www.steelnetwork.com/product/drift-trakdtsl>, 2 pg.

DrifTrak® DTSL, The Steel Network, downloaded from <https://www.steelnetwork.com/Product/DrifTrakDTSL>, available Apr. 1, 2016, 2 pgs.

DrifTrak® DTSLB, Tech Sheet, The Steel Network, Inc. (TSN), 2012, downloaded Jul. 6, 2017 from <https://web.archive.org/web/20121008022926/http://www.steelnetwork.com/product/drift-trakdtslb>, 3 pgs.

DWSC Slide Clips, FrameRite Connectors, Marino Ware, Jun. 16, 2016, downloaded from <http://www.marinoware.com/Products/frameriteConn.asp?prod=5>, 1 pg.

Extended FastClip™ (FCEC), Product Submittal Sheets, ClarkDietrich Building Systems, Oct. 2018, downloaded Oct. 23, 2020 from <https://www.clarkdietrich.com/products/curtain-wall-bypass-connections/extended-fastclip-fcec#submittals>, 5 pgs.

Fast Strut™ (FS12, FS15, FS18, FS20, FS22, FS24), Product Submittal Sheets, ClarkDietrich Building Systems, Sep. 2020, downloaded Oct. 23, 2020 from <https://www.clarkdietrich.com/products/curtain-wall-bypass-connections/fast-strut-fs12-fs15-fs18-fs20-fs22-fs24#submittals>, 6 pgs.

Fast Top™ Clip (FTC), Product Submittal Sheets, ClarkDietrich Building Systems, Sep. 2020, downloaded Oct. 23, 2020 from <https://www.clarkdietrich.com/products/head-wall-deflection-connections/fast-top-clip-ftc#submittals>, 5 pgs.

FastClip™ Slide Clip (FCSC-HD) w/Anchor Holes, Product Submittal Sheet, ClarkDietrich Building Systems, Sep. 2020, downloaded Oct. 23, 2020 from <https://www.clarkdietrich.com/products/curtain-wall-bypass-connections/fastclip-slide-clip-fcsc-hd-w-anchor-holes#submittals>, 1 pg.

FastClip™ Slide Clips (FCSC), Product Submittal Sheets, ClarkDietrich Building Systems, Jan. 2020, downloaded Oct. 23, 2020 from <https://www.clarkdietrich.com/products/curtain-wall-bypass-connections/fastclip-slide-clips-fcsc#submittals>, 3 pgs.

Flat Tail™ Slide Clip (FTSC), Product Submittal Sheets, ClarkDietrich Building Systems, Sep. 2020, downloaded Oct. 23, 2020 from <https://www.clarkdietrich.com/products/curtain-wall-bypass-connections/flat-tail-slide-clip-ftsc#submittals>, 4 pgs.

IDCB Drift-Clip Bypass Framing Connector, Catalog pages, Simpson Strong-Tie, 2000, downloaded Oct. 27, 2020 from https://www.strongtie.com/driftconnectors_coldformedsteelconstruction/idcb_clip/p/idcb, 1 pg.

MasterClip® VLB, Bypass Slab, Tech Sheet, The Steel Network, Inc., May 2019, downloaded Oct. 27, 2020 from <https://steelnetwork.com/Product/MastorClipVLB>, 2 pgs.

PLC2—Bypass Slab Slide Clip, SCAFCO Steel Stud Company, 2000, downloaded Oct. 27, 2020 from <https://www.scafco.com/steel/products/deflection-clips/plc2-bypass-slab-slide-clip/>, 3 pgs.

PLC4—Bypass Slab Slide Clip, SCAFCO Steel Stud Company, Jun. 7, 2017, downloaded from <http://www.scafco.com/steel/products/deflection-clips/plc4-bypass-slide-clip>, 2 pgs.

SC Bypass Framing Slide-Clip Connector, Catalog pages, Simpson Strong-Tie, 2000, downloaded Oct. 27, 2020 from https://www.strongtie.com/deflectionconnectors_coldformedsteelconstruction/sc_sclip/p/sc, 4 pgs.

SCB/MSCB Bypass Framing Slide-Clip Connectors, Catalog pages, Simpson Strong-Tie, 2000, downloaded Oct. 27, 2020 from https://www.strongtie.com/deflectionconnectors_coldformedsteelconstruction/scb_clip/p/scb.msrb, 3 pgs.

SCHA Slide-Clip Connectors for Horizontal Anchorage, Tech Sheet, Simpson Strong-Tie Company, Inc., Jan. 2016, 4 pgs.

SCS Seismic Bypass Framing Connector, Catalog pages, Simpson Strong-Tie, 2000, downloaded Oct. 27, 2020 from https://www.strongtie.com/deflectionconnectors_coldformedsteelconstruction/scs_clip/p/scs, 6 pgs.

SCW Head-of-Wall Slide-Clip Connectors, Submittal/Substitution Technical Information, Simpson Strong-Tie Company, Inc., Aug. 2016, 1 pg.

Simpson Strong-Tie SCW5.5-KT 5.5" Head-of-Wall Slide-Clip Connector Kit 25 pk, Nov. 19, 2016, downloaded from <http://www.fastoolnow.com/scw5-5-kt.html>, 3 pgs.

SmartFrame® VertiFlex™ SFVF, CRACO Mfg, SmartFrame® Connector System Product Catalog, Jan. 2020, p. 6, downloaded Oct. 27, 2020 from <https://cracometals.com/wp-content/uploads/2020/06/SmartFrame-Connectors-Catalog-2020.pdf>, 3 pgs.

Universal ByPass Clips (UBS), Product Submittal Sheets, ClarkDietrich Building Systems, Sep. 2020, downloaded Oct. 23, 2020 from <https://www.clarkdietrich.com/products/curtain-wall-bypass-connections/universal-bypass-clips-ubc#submittals>, 8 pgs.

VertiClip® SLB, Bypass Slab, Tech Sheet, The Steel Network, Inc., Oct. 2019, downloaded Oct. 27, 2020 from <https://steelnetwork.com/Product/VertiClipSLB>, 2 pgs.

VertiClip® SLB-HD, Bypass Slab for Seismic Conditions, Tech Sheet, The Steel Network, Inc., Dec. 2017, downloaded Oct. 27, 2020 from <https://steelnetwork.com/Product/VertiClipSLB-HD>, 1 pg.

VertiClip® SLD Metal Stud Connector for Light Gauge Steel Vertical Deflection, CAP Industries, Drywall trims, Nov. 22, 2016, downloaded from <http://www.drywalltrims.com/product/VertiClipSLD.html>, 3 pgs.

VertiClip® SLD, Interior Head of Wall, The Steel Network, Inc., Tech Sheet, Catalog pp. 11-12, 2016, downloaded from <https://www.steelnetwork.com/Product/VertiClipSLD>, 2 pgs.

WSC Slide Clips, MarinoWARE, 2000, downloaded Oct. 27, 2020 from <https://www.marinoware.com/product/wsc-slide-clips/>, 2 pgs. Design U.S. Appl. No. 29/743,534, filed Jul. 22, 2020, by Stahl, et al., entitled: "Slide Clip."

Design U.S. Appl. No. 29/743,534.

DSSCB Bypass Framing Drift Strut Connector, Simpson Strong-Tie, 2020, downloaded Oct. 4, 2021 from https://www.strongtie.com/driftconnectors_coldformedsteelconstruction/dsscb_clip/p/dsscb#ProductDetails, 8 pgs. U.S. Appl. No. 17/381,436.

* cited by examiner

Primary Examiner — Leanne Was-Englehart

(74) Attorney, Agent, or Firm — Frost Brown Todd LLC

(57) CLAIM

The ornamental design for a slide clip, as shown and described.

DESCRIPTION

FIG. 1 is a front perspective view of a slide clip, showing our new design;

FIG. 2 is a rear perspective view of the slide clip of FIG. 1;

FIG. 3 is a front elevational view of the slide clip of FIG. 1;

FIG. 4 is a rear elevational view of the slide clip of FIG. 1;

FIG. 5 is a left elevational view of the slide clip of FIG. 1;

FIG. 6 is a right elevational view of the slide clip of FIG. 1;

FIG. 7 is a top plan view of the slide clip of FIG. 1;

FIG. 8 is a bottom plan view of the slide clip of FIG. 1;

FIG. 9 is a perspective assembly view of the slide clip of FIG. 1 installed in an exemplary building structure;

FIG. 10 is a front perspective view of a second embodiment of a slide clip, showing our new design;

FIG. 11 is a rear perspective view of the slide clip of FIG. 10;

FIG. 12 is a front elevational view of the slide clip of FIG. 10;

FIG. 13 is a rear elevational view of the slide clip of FIG. 10;

FIG. 14 is a left elevational view of the slide clip of FIG. 10;

FIG. 15 is a right elevational view of the slide clip of FIG. 10;

FIG. 16 is a top plan view of the slide clip of FIG. 10;

FIG. 17 is a bottom plan view of the slide clip of FIG. 10; and,

FIG. 18 is a perspective assembly view of the slide clip of FIG. 10 installed in an exemplary building structure.

The slide clip is shown with two symbolic breaks in the length of the second plate of the slide clip. The appearance of any portion of the slide clip between the break lines forms no part of the claimed design. The through holes in the first plate shown in broken lines in FIGS. 1, 2, 5, 6, 9, 10, 11, 14, 15, and 18, the through holes in the second plate shown in broken lines in FIGS. 1-4, 9-13, and 18, the stiffeners on the first plate and in the juncture shown in broken lines in FIGS. 1-18, the indicator marks on the first plate shown in broken lines in FIGS. 1, 6, 9, 10, 15, and 18, and the indicator marks on the second plate shown in broken lines in FIGS. 1, 3, 9, 10, 12, and 18 are unclaimed subject matter and form no part of the claimed design. In addition, the fasteners and building structure shown in broken lines in FIGS. 9 and 18 are unclaimed subject matter and form no part of the claimed design. The embossments shown in broken lines on the second plate in FIGS. 10-18 are unclaimed subject matter for the embodiment shown in FIGS. 10-18. However, the embossments shown in solid lines on the second plate in FIGS. 1-9 are claimed subject matter for the embodiment shown in FIGS. 1-9.

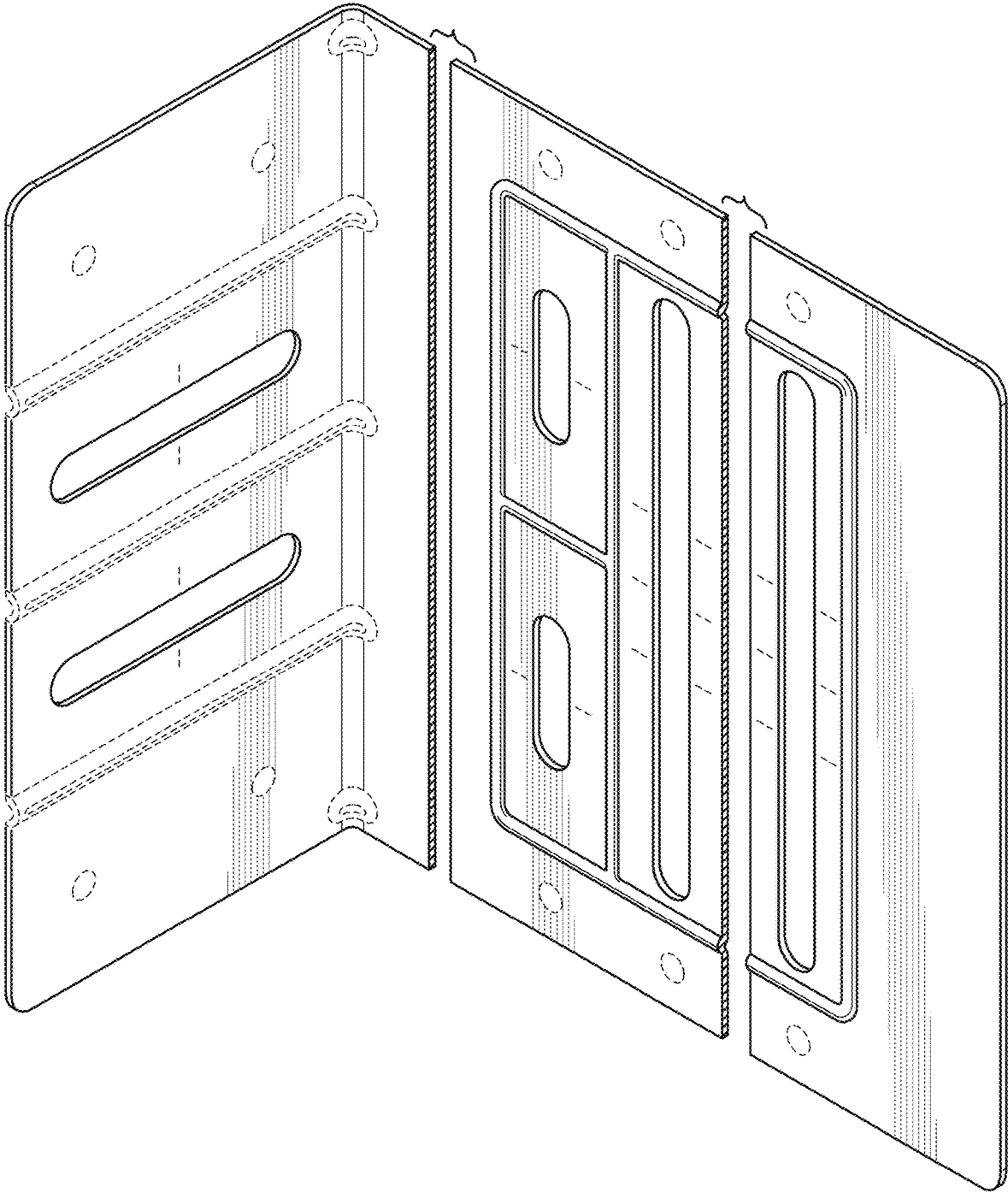

FIG. 1

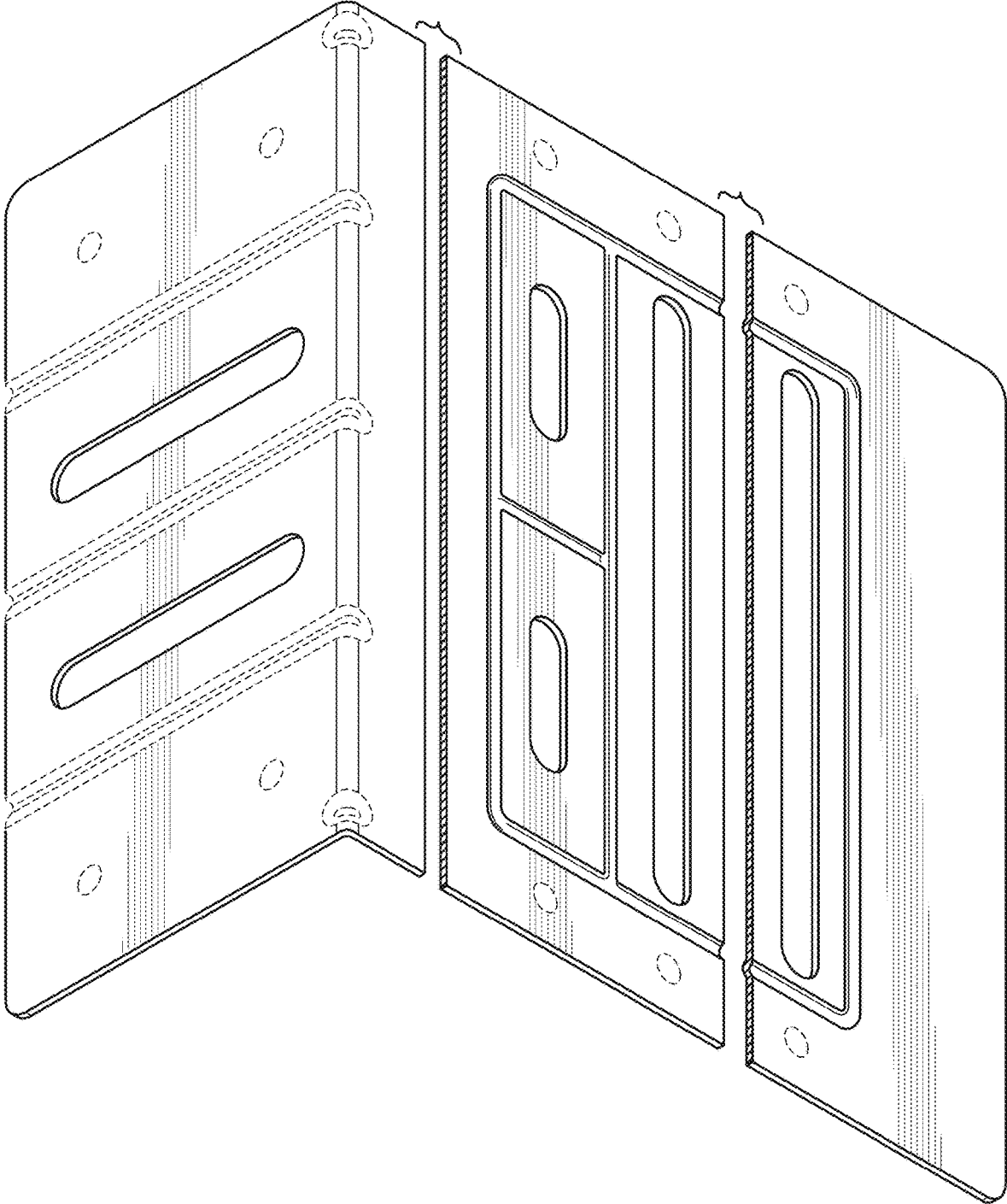

FIG. 2

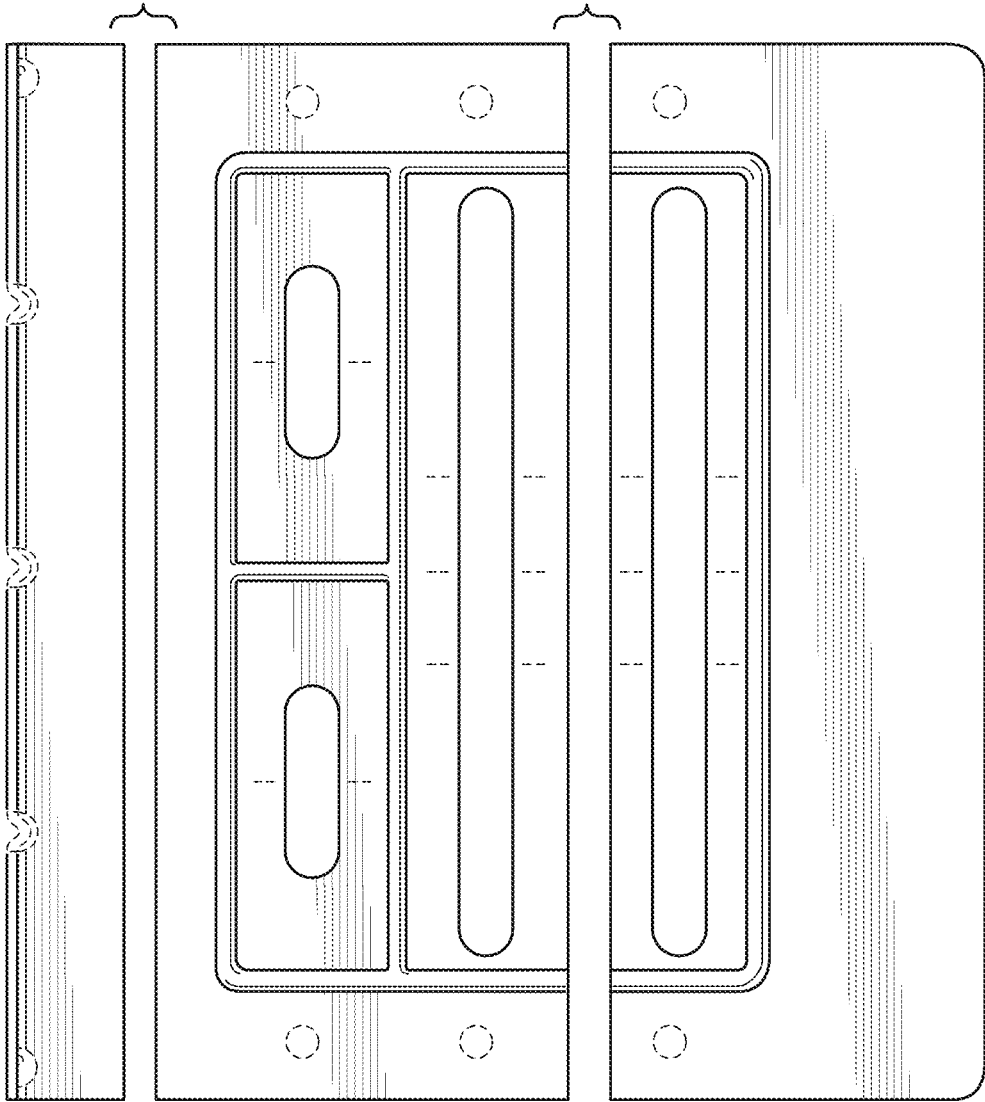

FIG. 3

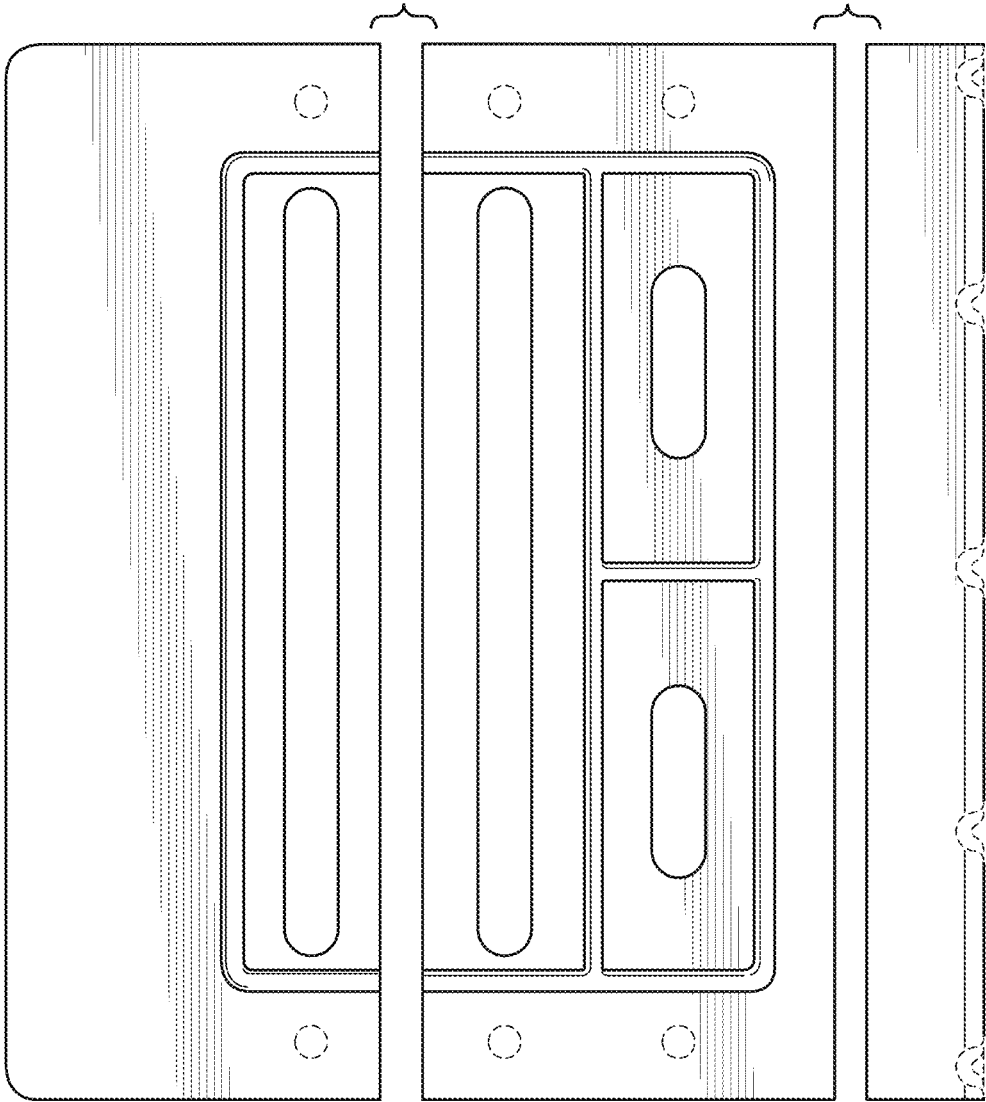

FIG. 4

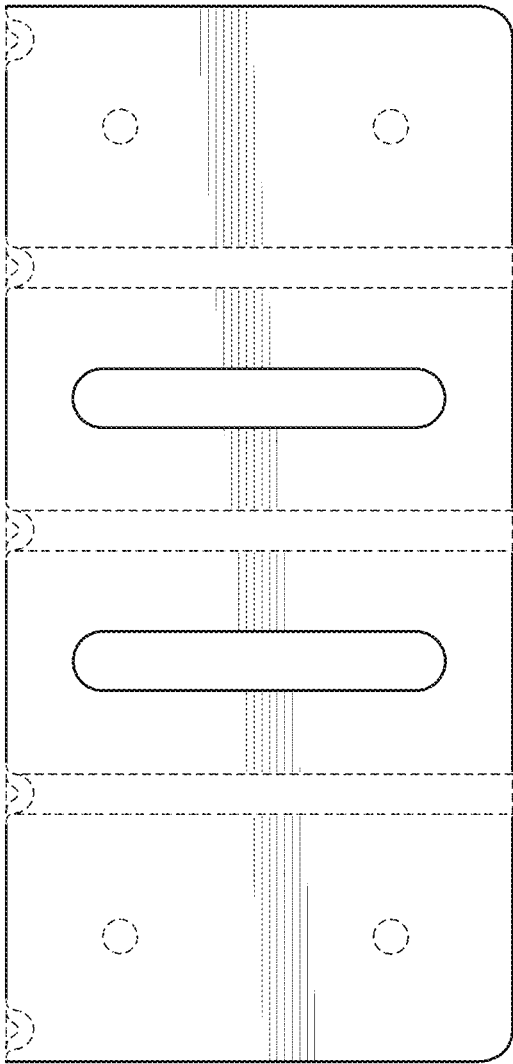

FIG. 5

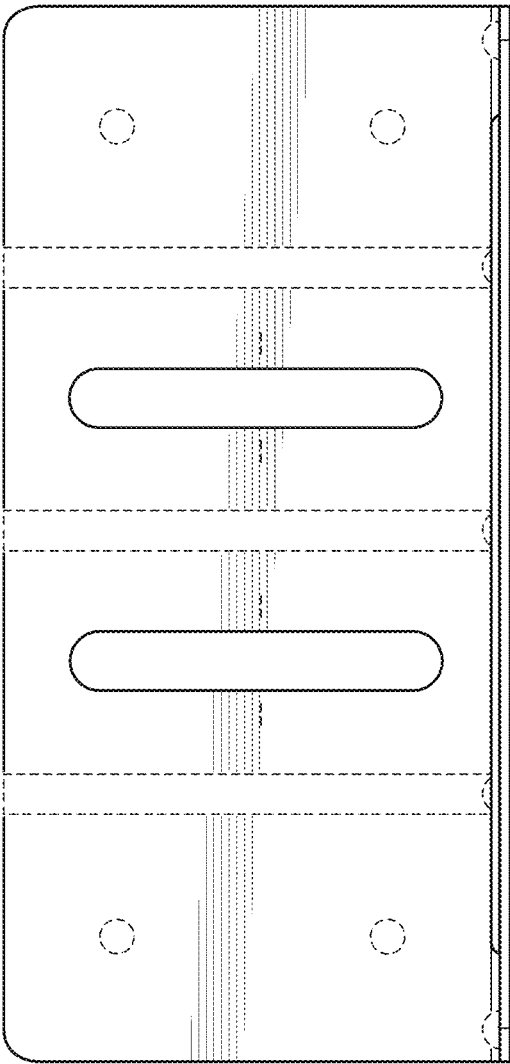

FIG. 6

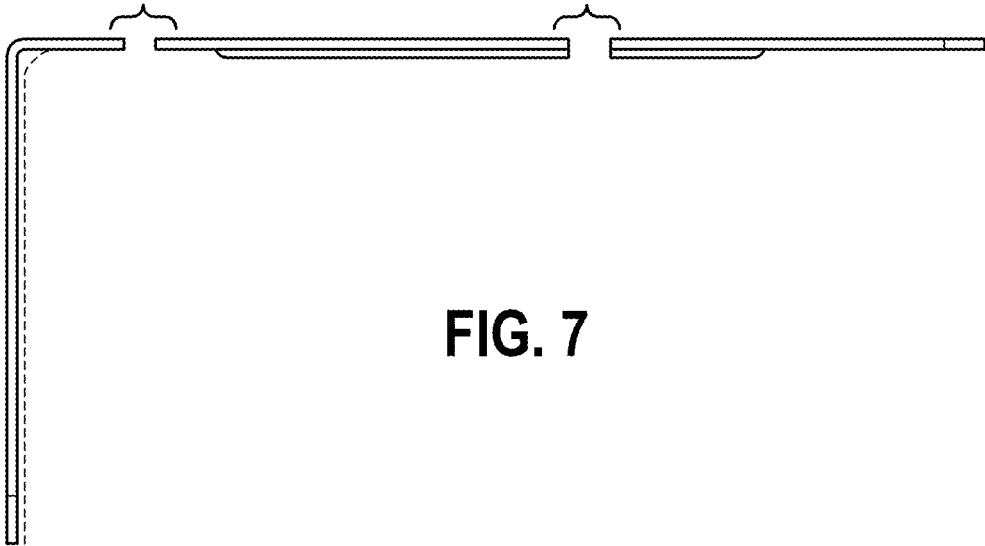

FIG. 7

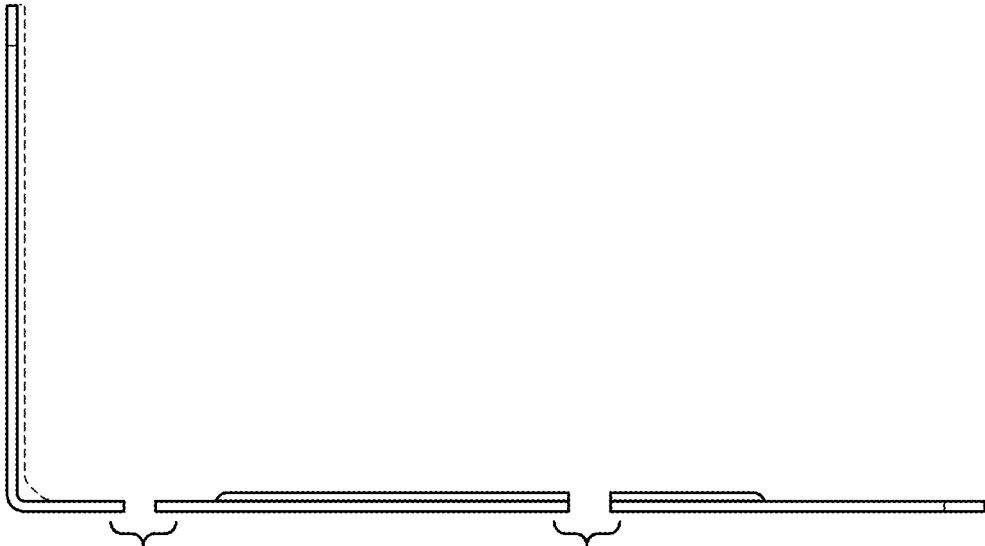

FIG. 8

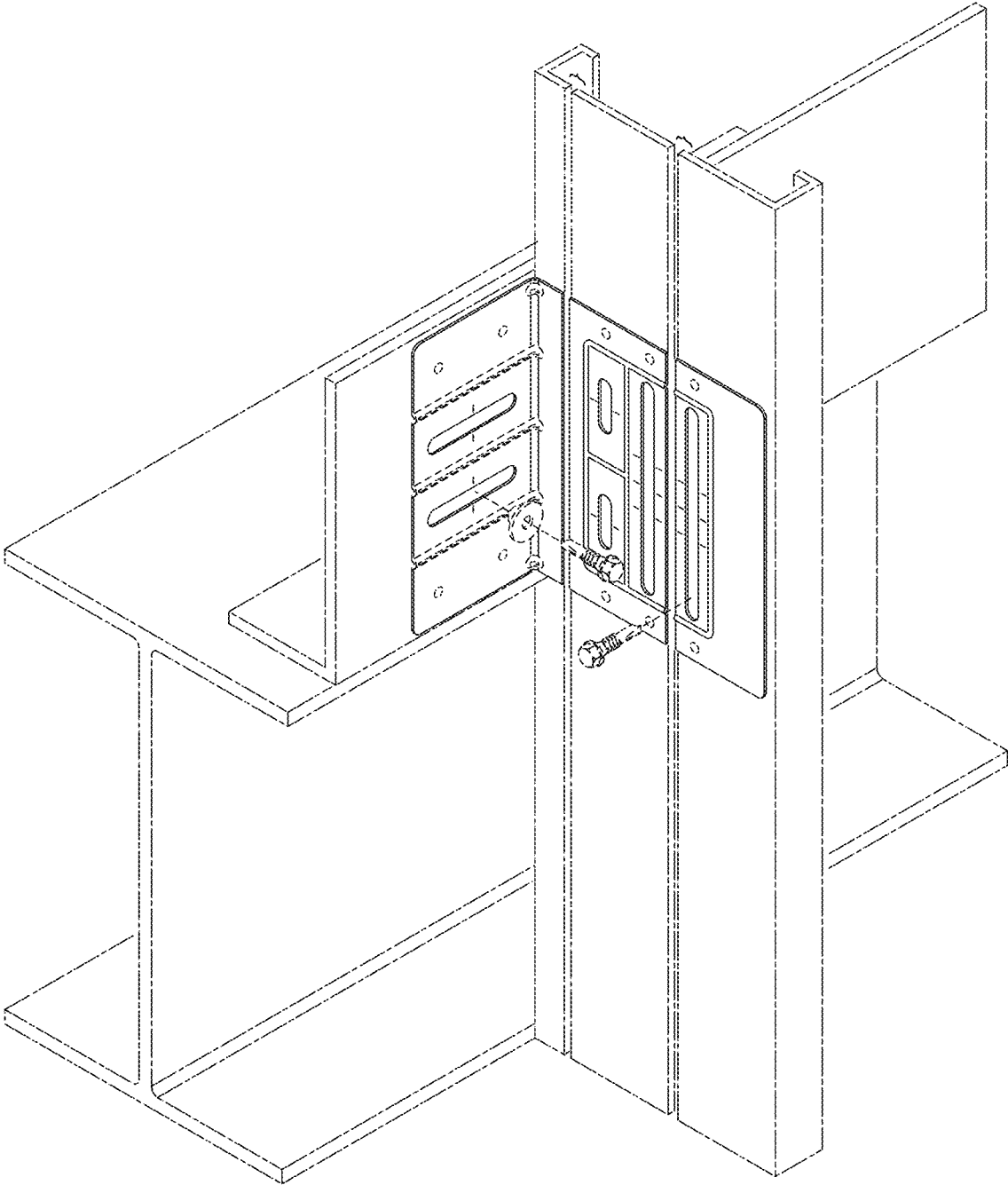

FIG. 9

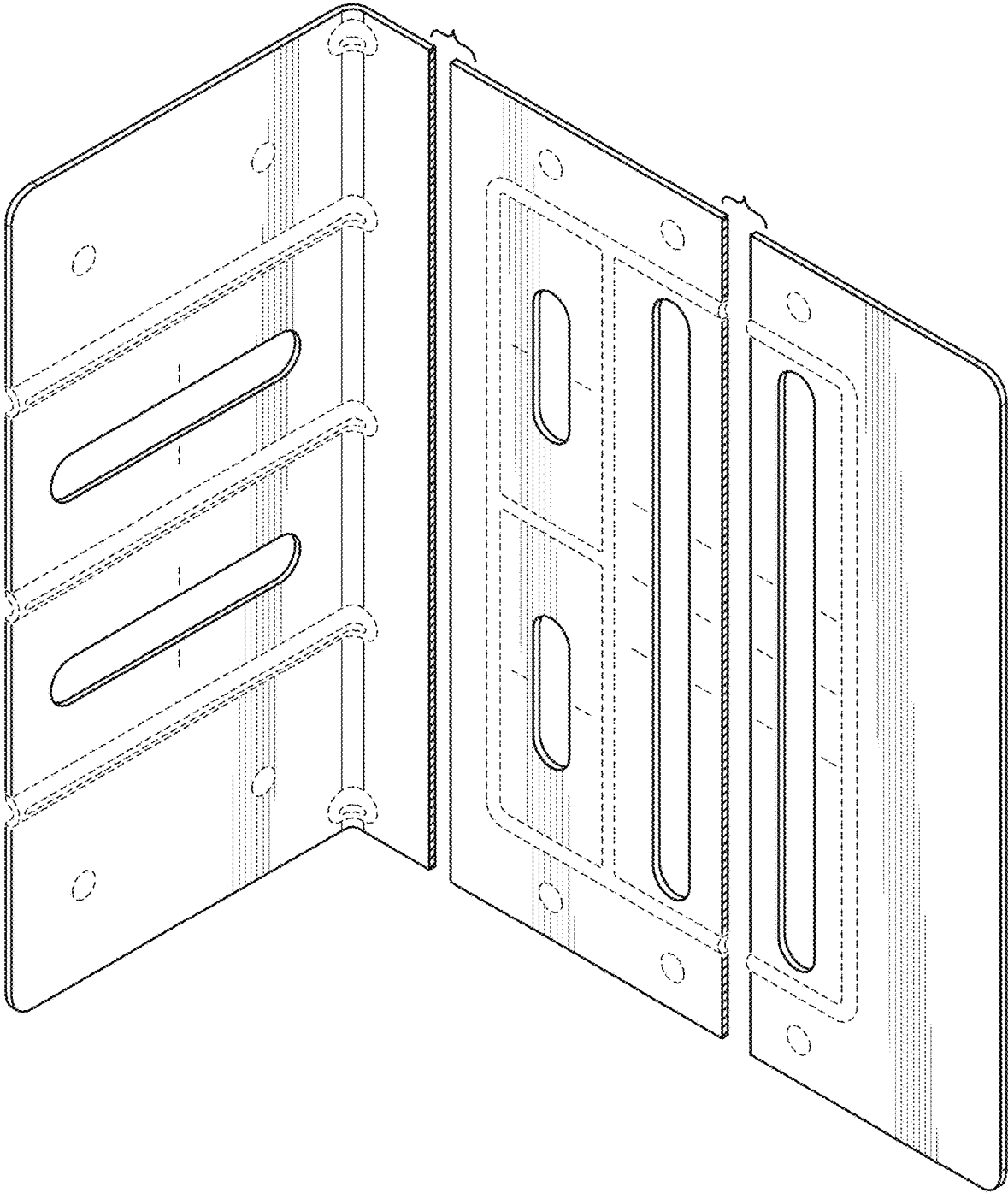

FIG. 10

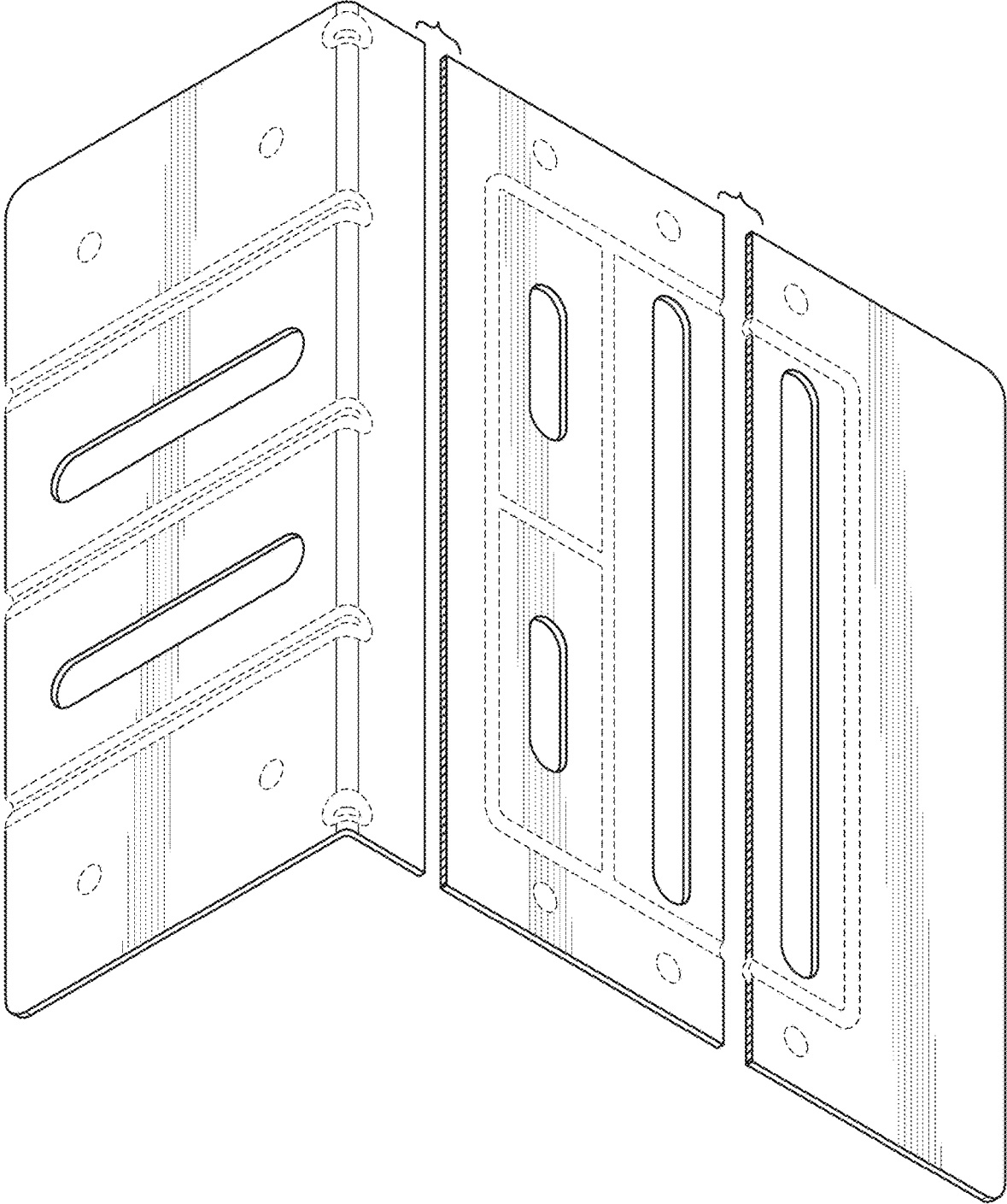

FIG. 11

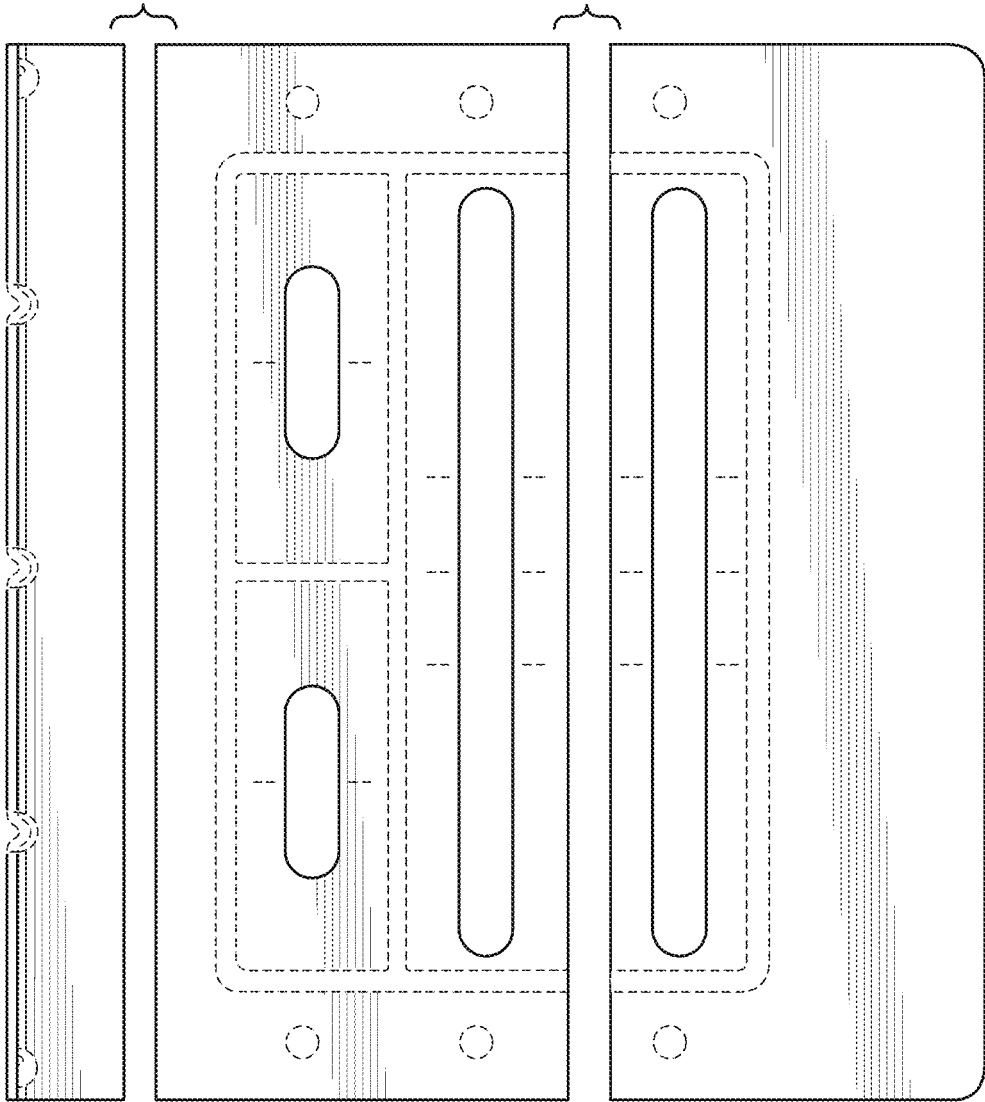

FIG. 12

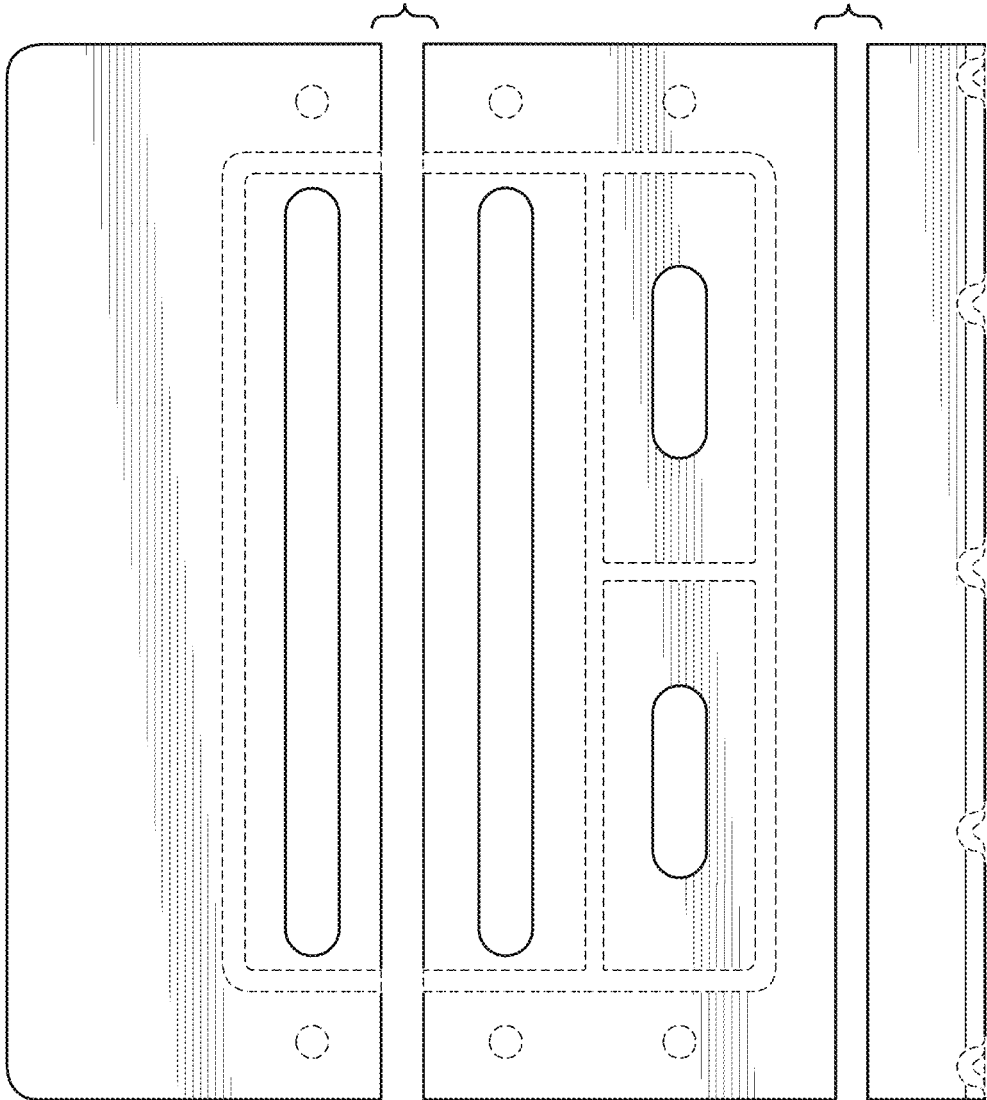

FIG. 13

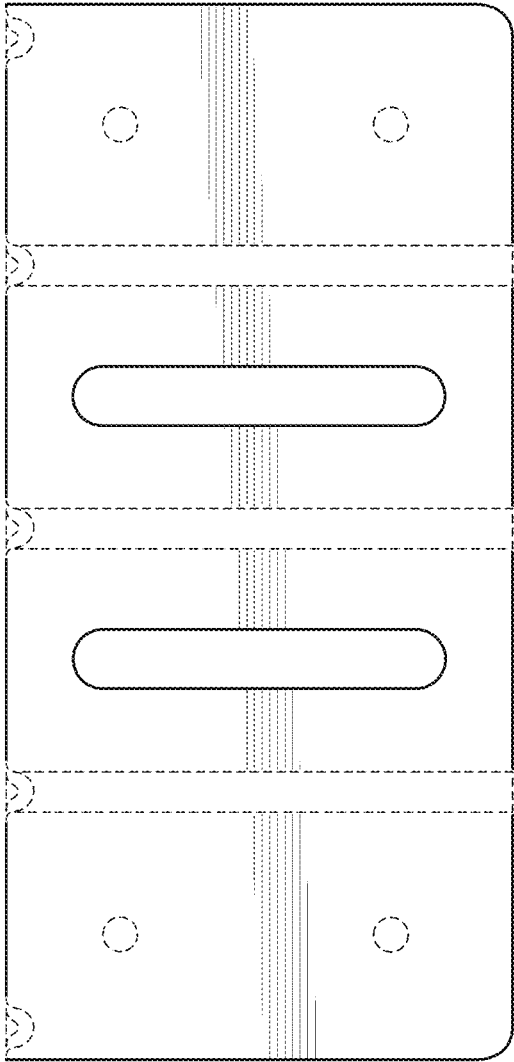

FIG. 14

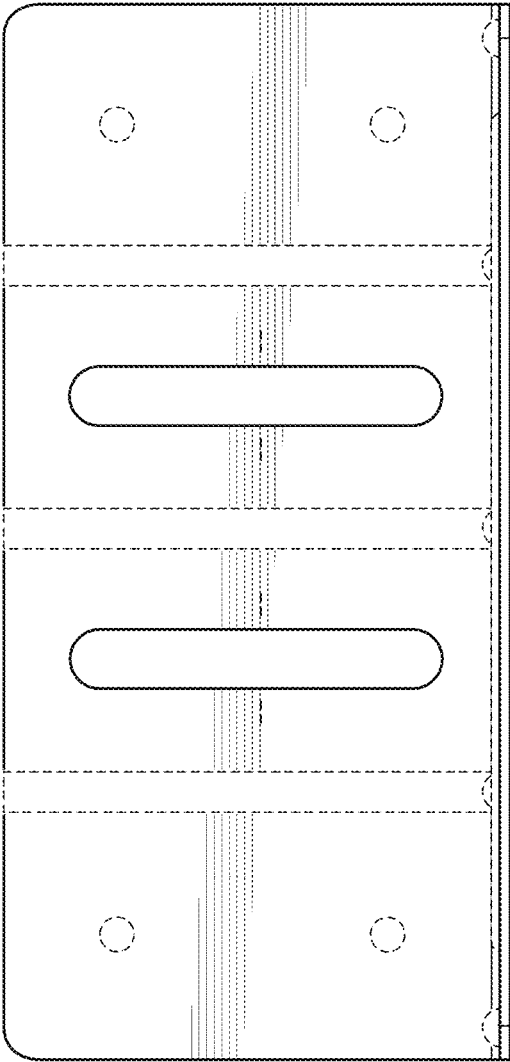

FIG. 15

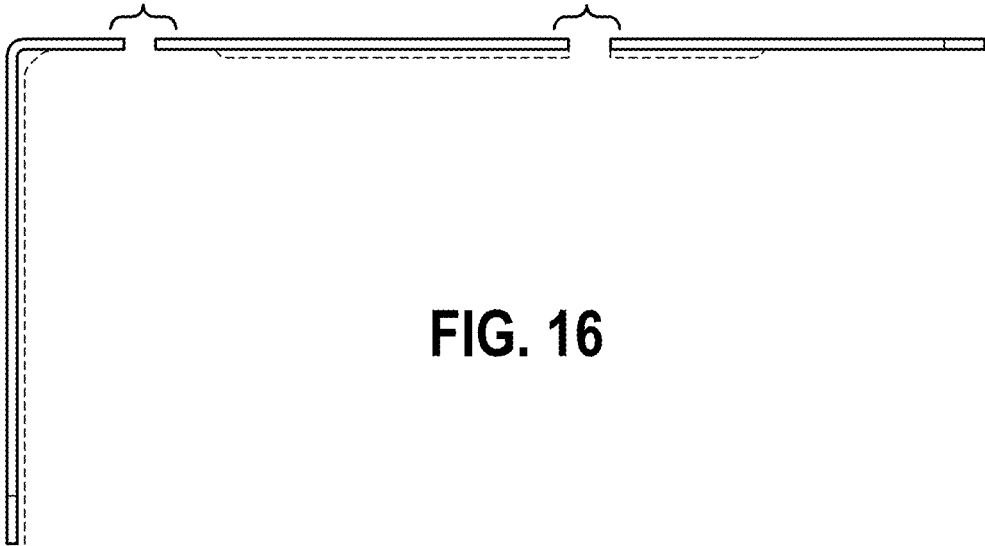

FIG. 16

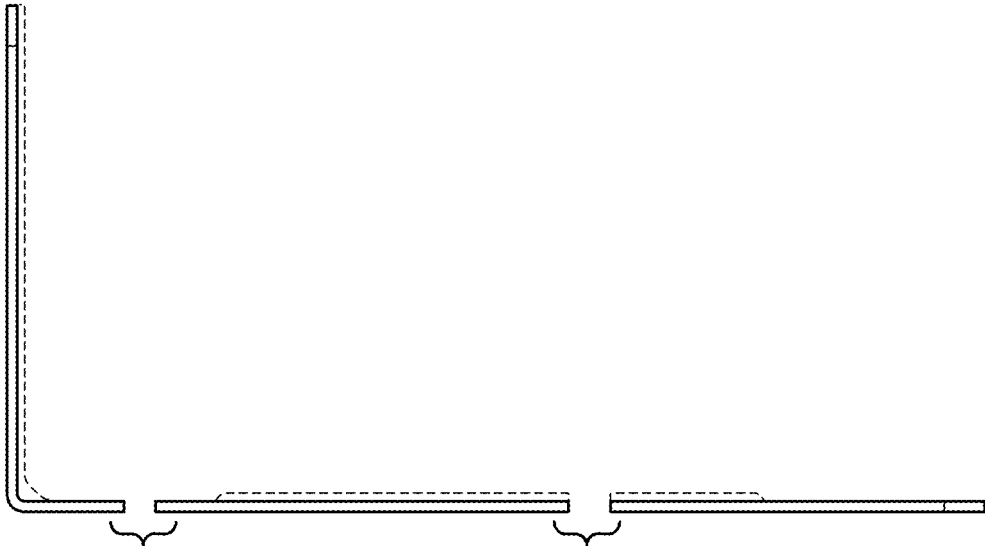

FIG. 17

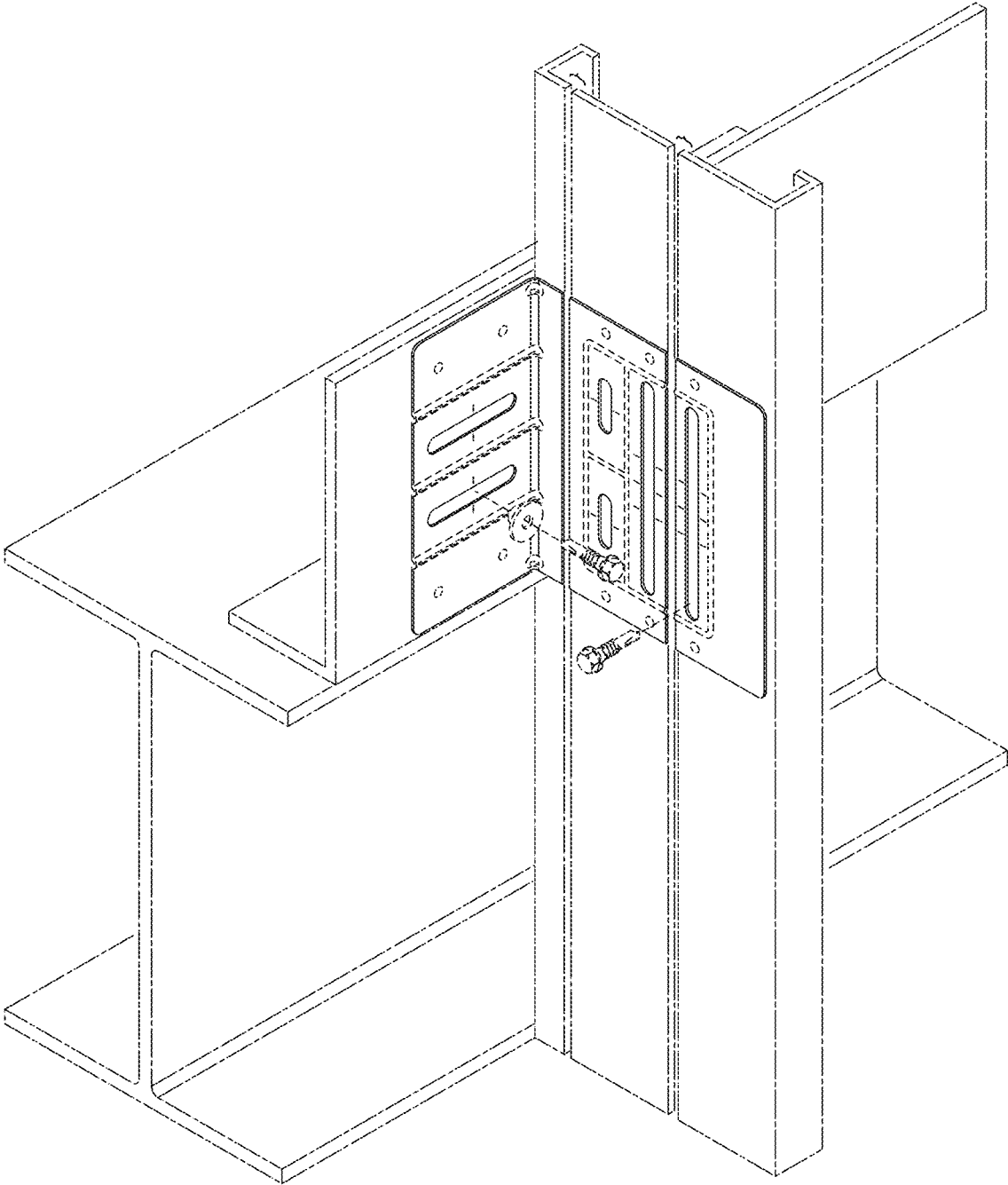

FIG. 18