



- (51) **International Patent Classification:**  
G02B 27/22 (2006.01)
- (21) **International Application Number:**  
PCT/US2018/066419
- (22) **International Filing Date:**  
19 December 2018 (19.12.2018)
- (25) **Filing Language:** English
- (26) **Publication Language:** English
- (30) **Priority Data:**  
62/607,377 19 December 2017 (19.12.2017) US
- (71) **Applicant: E INK CORPORATION [US/US];** Attn: IP Department, 1000 Technology Park Drive, Billerica, Massachusetts 01821-4165 (US).
- (72) **Inventors: ANSETH, Jay William;** c/o E Ink Corporation, 1000 Technology Park Drive, Billerica, Massachusetts 01821-4165 (US). **PAOLINI, Richard J., Jr.;** c/o E Ink

Corporation, 1000 Technology Park Drive, Billerica, Massachusetts 01821-4165 (US). **TELFER, Stephen J.;** c/o E Ink Corporation, 1000 Technology Park Drive, Billerica, Massachusetts 01821-4165 (US). **KANN, Yelena;** c/o E Ink Corporation, 1000 Technology Park Drive, Billerica, Massachusetts 01821-4165 (US). **BLAINE, Thomas S.;** c/o E Ink Corporation, 1000 Technology Park Drive, Billerica, Massachusetts 01821-4165 (US). **MURARI, Nishit;** c/o E Ink Corporation, 1000 Technology Park Drive, Billerica, Massachusetts 01821-4165 (US).

(74) **Agent: COLE, David J. et al.;** E Ink Corporation, 1000 Technology Park Drive, Billerica, Massachusetts 01821-4165 (US).

(81) **Designated States** (*unless otherwise indicated, for every kind of national protection available*): AE, AG, AL, AM, AO, AT, AU, AZ, BA, BB, BG, BH, BN, BR, BW, BY, BZ, CA, CH, CL, CN, CO, CR, CU, CZ, DE, DJ, DK, DM, DO, DZ, EC, EE, EG, ES, FI, GB, GD, GE, GH, GM, GT, HN, HR, HU, ID, IL, IN, IR, IS, JO, JP, KE, KG, KH, KN, KP,

(54) **Title:** APPLICATIONS OF ELECTRO-OPTIC DISPLAYS

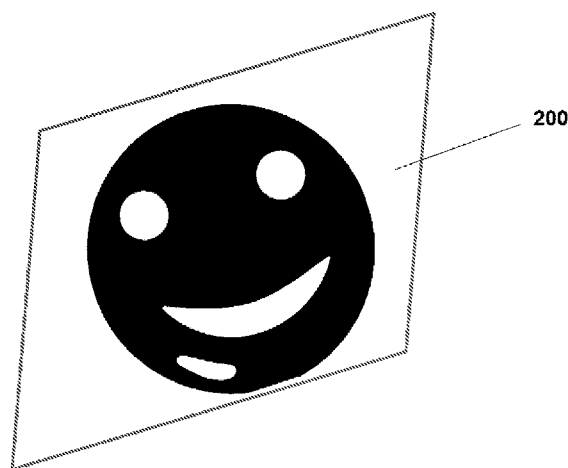

**Fig. 2**

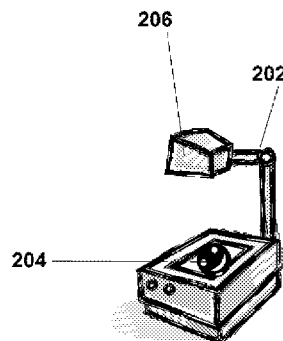

(57) **Abstract:** An image is formed on an architectural surface (200) by applying to the surface, in order: a rear electrode layer (112); a light-transmissive front electrode layer (104); a photoconductive layer (110) disposed between the front (104) and rear (112) electrode layers; and an electro-optic layer (106) disposed between the front (104) and rear (112) electrode layers. A potential difference is applied between the front (104) and rear (112) electrode layers and the front electrode layer (104) is imagewise exposed to radiation which causes a change in the conductivity of the photoconductive layer (110), thereby causing an imagewise change in the optical state of the electro-optic layer (106). Films (300, 406, 408) for application to architectural surfaces (302, 400) are also provided.



KR, KW, KZ, LA, LC, LK, LR, LS, LU, LY, MA, MD, ME, MG, MK, MN, MW, MX, MY, MZ, NA, NG, NI, NO, NZ, OM, PA, PE, PG, PH, PL, PT, QA, RO, RS, RU, RW, SA, SC, SD, SE, SG, SK, SL, SM, ST, SV, SY, TH, TJ, TM, TN, TR, TT, TZ, UA, UG, US, UZ, VC, VN, ZA, ZM, ZW.

- (84) Designated States** (*unless otherwise indicated, for every kind of regional protection available*): ARIPO (BW, GH, GM, KE, LR, LS, MW, MZ, NA, RW, SD, SL, ST, SZ, TZ, UG, ZM, ZW), Eurasian (AM, AZ, BY, KG, KZ, RU, TJ, TM), European (AL, AT, BE, BG, CH, CY, CZ, DE, DK, EE, ES, FI, FR, GB, GR, HR, HU, IE, IS, IT, LT, LU, LV, MC, MK, MT, NL, NO, PL, PT, RO, RS, SE, SI, SK, SM, TR), OAPI (BF, BJ, CF, CG, CI, CM, GA, GN, GQ, GW, KM, ML, MR, NE, SN, TD, TG).

**Declarations under Rule 4.17:**

- *as to applicant's entitlement to apply for and be granted a patent (Rule 4.17(ii))*

**Published:**

- *with international search report (Art. 21(3))*
- *before the expiration of the time limit for amending the claims and to be republished in the event of receipt of amendments (Rule 48.2(h))*

## APPLICATIONS OF ELECTRO-OPTIC DISPLAYS

**[Para 1]** This application is also related to U.S. Published Applications Serial Nos. 2016/0259225 and 2016/0232835; and U.S. Patents Nos. 6,445,489; 6,704,133; 6,753,999 and 6,825,829.

**[Para 2]** This invention relates to applications of electro-optic displays. More specifically, this invention relates to uses of electro-optic displays, especially but not exclusively, particle-based electrophoretic displays, in architectural, furnishing and similar applications.

**[Para 3]** The term "electro-optic", as applied to a material or a display, is used herein in its conventional meaning in the imaging art to refer to a material having first and second display states differing in at least one optical property, the material being changed from its first to its second display state by application of an electric field to the material. Although the optical property is typically color perceptible to the human eye, it may be another optical property, such as optical transmission, reflectance, luminescence or, in the case of displays intended for machine reading, pseudo-color in the sense of a change in reflectance of electromagnetic wavelengths outside the visible range.

**[Para 4]** The term "gray state" is used herein in its conventional meaning in the imaging art to refer to a state intermediate two extreme optical states of a pixel, and does not necessarily imply a black-white transition between these two extreme states. For example, several of the E Ink patents and published applications referred to below describe electrophoretic displays in which the extreme states are white and deep blue, so that an intermediate "gray state" would actually be pale blue. Indeed, as already mentioned, the change in optical state may not be a color change at all. The terms "black" and "white" may be used hereinafter to refer to the two extreme optical states of a display, and should be understood as normally including extreme optical states which are not strictly black and white, for example the aforementioned white and dark blue states. The term "monochrome" may be used hereinafter to denote a drive scheme which only drives pixels to their two extreme optical states with no intervening gray states.

**[Para 5]** Some electro-optic materials are solid in the sense that the materials have solid external surfaces, although the materials may, and often do, have internal liquid- or gas-filled spaces. Such displays using solid electro-optic materials may hereinafter for convenience be referred to as "solid electro-optic displays". Thus, the term "solid electro-optic displays" includes rotating bichromal member displays, encapsulated electrophoretic displays, microcell electrophoretic displays and encapsulated liquid crystal displays.

**[Para 6]** The terms "bistable" and "bistability" are used herein in their conventional meaning in the art to refer to displays comprising display elements having first and second display states differing in at least one optical property, and such that after any given element has been driven, by means of an addressing pulse of finite duration, to assume either its first or second display state, after the addressing pulse has terminated, that state will persist for at least several times, for example at least four times, the minimum duration of the addressing pulse required to change the state of the display element. It is shown in U.S. Patent No. 7,170,670 that some particle-based electrophoretic displays capable of gray scale are stable not only in their extreme black and white states but also in their intermediate gray states, and the same is true of some other types of electro-optic displays. This type of display is properly called "multi-stable" rather than bistable, although for convenience the term "bistable" may be used herein to cover both bistable and multi-stable displays.

**[Para 7]** Several types of electro-optic displays are known. These include rotating bichromal member displays as described, for example, in U.S. Patents Nos. 5,808,783; 5,777,782; 5,760,761; 6,054,071 6,055,091; 6,097,531; 6,128,124; 6,137,467; and 6,147,791 (although this type of display is often referred to as a "rotating bichromal ball" display, the term "rotating bichromal member" is preferred as more accurate since in some of the patents mentioned above the rotating members are not spherical). Another type of electro-optic display uses an electrochromic medium, for example an electrochromic medium in the form of a nanochromic film comprising an electrode formed at least in part from a semi-conducting metal oxide and a plurality of dye molecules capable of reversible color change attached to the electrode; see, for example O'Regan, B., et al., *Nature* 1991, 353, 737; and Wood, D., *Information Display*, 18(3), 24 (March 2002). See also Bach, U., et al., *Adv. Mater.*, 2002, 14(11), 845. Nanochromic films of this type are also described, for example, in U.S. Patents Nos. 6,301,038; 6,870,657; and 6,950,220. This type of medium is also typically bistable. Another type of electro-optic display is an electro-wetting display developed by Philips and described in Hayes, R.A., et al., "Video-Speed Electronic Paper Based on Electrowetting", *Nature*, 425, 383-385 (2003). It is shown in U.S. Patent No. 7,420,549 that such electro-wetting displays can be made bistable.

**[Para 8]** One type of electro-optic display, which has been the subject of intense research and development for a number of years, is the particle-based electrophoretic display, in which a plurality of charged particles move through a fluid under the influence of an electric field. Electrophoretic displays can have attributes of good brightness and contrast, wide viewing angles, state bistability, and low power consumption when compared with liquid crystal

displays. Nevertheless, problems with the long-term image quality of these displays have prevented their widespread usage. For example, particles that make up electrophoretic displays tend to settle, resulting in inadequate service-life for these displays.

**[Para 9]** As noted above, electrophoretic media require the presence of a fluid. In most prior art electrophoretic media, this fluid is a liquid, but electrophoretic media can be produced using gaseous fluids; see, for example, Kitamura, T., et al., "Electrical toner movement for electronic paper-like display", IDW Japan, 2001, Paper HCS1-1, and Yamaguchi, Y., et al., "Toner display using insulative particles charged triboelectrically", IDW Japan, 2001, Paper AMD4-4). See also U.S. Patents Nos. 7,321,459 and 7,236,291. Such gas-based electrophoretic media appear to be susceptible to the same types of problems due to particle settling as liquid-based electrophoretic media, when the media are used in an orientation which permits such settling, for example in a sign where the medium is disposed in a vertical plane. Indeed, particle settling appears to be a more serious problem in gas-based electrophoretic media than in liquid-based ones, since the lower viscosity of gaseous suspending fluids as compared with liquid ones allows more rapid settling of the electrophoretic particles.

**[Para 10]** Numerous patents and applications assigned to or in the names of the Massachusetts Institute of Technology (MIT), E Ink Corporation, E Ink California, LLC. and related companies describe various technologies used in encapsulated and microcell electrophoretic and other electro-optic media. Encapsulated electrophoretic media comprise numerous small capsules, each of which itself comprises an internal phase containing electrophoretically-mobile particles in a fluid medium, and a capsule wall surrounding the internal phase. Typically, the capsules are themselves held within a polymeric binder to form a coherent layer positioned between two electrodes. In a microcell electrophoretic display, the charged particles and the fluid are not encapsulated within microcapsules but instead are retained within a plurality of cavities formed within a carrier medium, typically a polymeric film. The technologies described in these patents and applications include:

- (a) Electrophoretic particles, fluids and fluid additives; see for example U.S. Patents Nos. 7,002,728 and 7,679,814;
- (b) Capsules, binders and encapsulation processes; see for example U.S. Patents Nos. 6,922,276 and 7,411,719;
- (c) Microcell structures, wall materials, and methods of forming microcells; see for example United States Patents Nos. 7,072,095 and 9,279,906;

(d) Methods for filling and sealing microcells; see for example United States Patents Nos. 7,144,942 and 7,715,088;

(e) Films and sub-assemblies containing electro-optic materials; see for example U.S. Patents Nos. 6,825,829; 6,982,178; 7,112,114; 7,158,282; 7,236,292; 7,443,571; 7,513,813; 7,561,324; 7,636,191; 7,649,666; 7,728,811; 7,729,039; 7,791,782; 7,839,564; 7,843,621; 7,843,624; 8,034,209; 8,068,272; 8,077,381; 8,177,942; 8,390,301; 8,482,835; 8,786,929; 8,830,553; 8,854,721; 9,075,280; and 9,238,340; and U.S. Patent Applications Publication Nos. 2007/0237962; 2009/0109519; 2009/0168067; 2011/0164301; 2014/0115884; and 2014/0340738;

(f) Backplanes, adhesive layers and other auxiliary layers and methods used in displays; see for example U.S. Patents Nos. 7,116,318 and 7,535,624;

(g) Color formation and color adjustment; see for example U.S. Patents Nos. 6,017,584; 6,545,797; 6,664,944; 6,788,452; 6,864,875; 6,914,714; 6,972,893; 7,038,656; 7,038,670; 7,046,228; 7,052,571; 7,075,502; 7,167,155; 7,385,751; 7,492,505; 7,667,684; 7,684,108; 7,791,789; 7,800,813; 7,821,702; 7,839,564; 7,910,175; 7,952,790; 7,956,841; 7,982,941; 8,040,594; 8,054,526; 8,098,418; 8,159,636; 8,213,076; 8,363,299; 8,422,116; 8,441,714; 8,441,716; 8,466,852; 8,503,063; 8,576,470; 8,576,475; 8,593,721; 8,605,354; 8,649,084; 8,670,174; 8,704,756; 8,717,664; 8,786,935; 8,797,634; 8,810,899; 8,830,559; 8,873,129; 8,902,153; 8,902,491; 8,917,439; 8,964,282; 9,013,783; 9,116,412; 9,146,439; 9,164,207; 9,170,467; 9,170,468; 9,182,646; 9,195,111; 9,199,441; 9,268,191; 9,285,649; 9,293,511; 9,341,916; 9,360,733; 9,361,836; 9,383,623; and 9,423,666; and U.S. Patent Applications Publication Nos. 2008/0043318; 2008/0048970; 2009/0225398; 2010/0156780; 2011/0043543; 2012/0326957; 2013/0242378; 2013/0278995; 2014/0055840; 2014/0078576; 2014/0340430; 2014/0340736; 2014/0362213; 2015/0103394; 2015/0118390; 2015/0124345; 2015/0198858; 2015/0234250; 2015/0268531; 2015/0301246; 2016/0011484; 2016/0026062; 2016/0048054; 2016/0116816; 2016/0116818; and 2016/0140909;

(h) Methods for driving displays; see for example U.S. Patents Nos. 5,930,026; 6,445,489; 6,504,524; 6,512,354; 6,531,997; 6,753,999; 6,825,970; 6,900,851; 6,995,550; 7,012,600; 7,023,420; 7,034,783; 7,061,166; 7,061,662; 7,116,466; 7,119,772; 7,177,066; 7,193,625; 7,202,847; 7,242,514; 7,259,744; 7,304,787; 7,312,794; 7,327,511; 7,408,699; 7,453,445; 7,492,339; 7,528,822; 7,545,358; 7,583,251; 7,602,374; 7,612,760; 7,679,599; 7,679,813; 7,683,606; 7,688,297; 7,729,039; 7,733,311; 7,733,335; 7,787,169; 7,859,742; 7,952,557; 7,956,841; 7,982,479; 7,999,787; 8,077,141; 8,125,501; 8,139,050;

8,174,490; 8,243,013; 8,274,472; 8,289,250; 8,300,006; 8,305,341; 8,314,784; 8,373,649; 8,384,658; 8,456,414; 8,462,102; 8,514,168; 8,537,105; 8,558,783; 8,558,785; 8,558,786; 8,558,855; 8,576,164; 8,576,259; 8,593,396; 8,605,032; 8,643,595; 8,665,206; 8,681,191; 8,730,153; 8,810,525; 8,928,562; 8,928,641; 8,976,444; 9,013,394; 9,019,197; 9,019,198; 9,019,318; 9,082,352; 9,171,508; 9,218,773; 9,224,338; 9,224,342; 9,224,344; 9,230,492; 9,251,736; 9,262,973; 9,269,311; 9,299,294; 9,373,289; 9,390,066; 9,390,661; and 9,412,314; and U.S. Patent Applications Publication Nos. 2003/0102858; 2004/0246562; 2005/0253777; 2007/0091418; 2007/0103427; 2007/0176912; 2008/0024429; 2008/0024482; 2008/0136774; 2008/0291129; 2008/0303780; 2009/0174651; 2009/0195568; 2009/0322721; 2010/0194733; 2010/0194789; 2010/0220121; 2010/0265561; 2010/0283804; 2011/0063314; 2011/0175875; 2011/0193840; 2011/0193841; 2011/0199671; 2011/0221740; 2012/0001957; 2012/0098740; 2013/0063333; 2013/0194250; 2013/0249782; 2013/0321278; 2014/0009817; 2014/0085355; 2014/0204012; 2014/0218277; 2014/0240210; 2014/0240373; 2014/0253425; 2014/0292830; 2014/0293398; 2014/0333685; 2014/0340734; 2015/0070744; 2015/0097877; 2015/0109283; 2015/0213749; 2015/0213765; 2015/0221257; 2015/0262255; 2015/0262551; 2016/0071465; 2016/0078820; 2016/0093253; 2016/0140910; and 2016/0180777;

(i) Applications of displays; see for example U.S. Patents Nos. 6,118,426; 6,473,072; 6,704,133; 6,710,540; 6,738,050; 6,825,829; 7,030,854; 7,119,759; 7,312,784; 7,705,824; 8,009,348; 8,011,592; 8,064,962; 8,162,212; 8,553,012; 8,973,837; 9,188,829; and 9,197,704; and U.S. Patent Applications Publication Nos. 2002/0090980; 2004/0119681; 2007/0285385; 2013/0176288; 2013/0221112; 2013/0233930; 2013/0235536; 2014/0049808; 2014/0062391; 2014/0206292; and 2016/0035291; and International Application Publication No. WO 00/36560 (and see also IP.com Prior Art Database Technical Disclosures Nos. 000244343 and 000238455, published by ip.com, of 370 Woodcliff Drive, Suite 301, Fairport NY 14450); and

(j) Non -electrophoretic displays, as described in U.S. Patent No. 6,241,921; 6,784,953 and U.S. Patent Application Publication No. 2015/0277160; and applications of encapsulation and microcell technology other than displays; see for example United States Patent No. 7,615,325; and U.S. Patent Application Publications Nos. 2015/0005720 and 2016/0012710.

**[Para 11]** Many of the aforementioned patents and applications recognize that the walls surrounding the discrete microcapsules in an encapsulated electrophoretic medium could be replaced by a continuous phase, thus producing a so-called polymer-dispersed electrophoretic

display, in which the electrophoretic medium comprises a plurality of discrete droplets of an electrophoretic fluid and a continuous phase of a polymeric material, and that the discrete droplets of electrophoretic fluid within such a polymer-dispersed electrophoretic display may be regarded as capsules or microcapsules even though no discrete capsule membrane is associated with each individual droplet; see for example, the aforementioned U.S. Patent No. 6,866,760. Accordingly, for purposes of the present application, such polymer-dispersed electrophoretic media are regarded as sub-species of encapsulated electrophoretic media.

**[Para 12]** Although electrophoretic media are often opaque (since, for example, in many electrophoretic media, the particles substantially block transmission of visible light through the display) and operate in a reflective mode, many electrophoretic displays can be made to operate in a so-called "shutter mode" in which one display state is substantially opaque and one is light-transmissive. See, for example, U.S. Patents Nos. 5,872,552; 6,130,774; 6,144,361; 6,172,798; 6,271,823; 6,225,971; and 6,184,856. Dielectrophoretic displays, which are similar to electrophoretic displays but rely upon variations in electric field strength, can operate in a similar mode; see U.S. Patent No. 4,418,346. Other types of electro-optic displays may also be capable of operating in shutter mode. Electro-optic media operating in shutter mode may be useful in multi-layer structures for full color displays; in such structures, at least one layer adjacent the viewing surface of the display operates in shutter mode to expose or conceal a second layer more distant from the viewing surface.

**[Para 13]** An encapsulated electrophoretic display typically does not suffer from the clustering and settling failure mode of traditional electrophoretic devices and provides further advantages, such as the ability to print or coat the display on a wide variety of flexible and rigid substrates. (Use of the word "printing" is intended to include all forms of printing and coating, including, but without limitation: pre-metered coatings such as patch die coating, slot or extrusion coating, slide or cascade coating, curtain coating; roll coating such as knife over roll coating, forward and reverse roll coating; gravure coating; dip coating; spray coating; meniscus coating; spin coating; brush coating; air knife coating; silk screen printing processes; electrostatic printing processes; thermal printing processes; ink jet printing processes; electrophoretic deposition (See U.S. Patent No. 7,339,715); and other similar techniques.) Thus, the resulting display can be flexible. Further, because the display medium can be printed (using a variety of methods), the display itself can be made inexpensively.

**[Para 14]** Other types of electro-optic materials may also be used in the present invention.



**[Para 15]** An electro-optic display normally comprises a layer of electro-optic material and at least two other layers disposed on opposed sides of the electro-optic material, one of these two layers being an electrode layer. In most such displays both the layers are electrode layers, and one or both of the electrode layers are patterned to define the pixels of the display. For example, one electrode layer may be patterned into elongate row electrodes and the other into elongate column electrodes running at right angles to the row electrodes, the pixels being defined by the intersections of the row and column electrodes. Alternatively, and more commonly, one electrode layer has the form of a single continuous electrode and the other electrode layer is patterned into a matrix of pixel electrodes, each of which defines one pixel of the display. In another type of electro-optic display, which is intended for use with a stylus, print head or similar movable electrode separate from the display, only one of the layers adjacent the electro-optic layer comprises an electrode, the layer on the opposed side of the electro-optic layer typically being a protective layer intended to prevent the movable electrode damaging the electro-optic layer.

**[Para 16]** As discussed in the aforementioned U.S. Patent No. 6,982,178, (see column 3, lines 63 to column 5, line 46) many of the components used in solid electro-optic displays, and the methods used to manufacture such displays, are derived from technology used in liquid crystal displays (LCD's), which are of course also electro-optic displays, though using a liquid rather than a solid medium. For example, solid electro-optic displays may make use of an active matrix backplane comprising an array of transistors or diodes and a corresponding array of pixel electrodes, and a "continuous" front electrode (in the sense of an electrode which extends over multiple pixels and typically the whole display) on a transparent substrate, these components being essentially the same as in LCD's. However, the methods used for assembling LCD's cannot be used with solid electro-optic displays. LCD's are normally assembled by forming the backplane and front electrode on separate glass substrates, then adhesively securing these components together leaving a small aperture between them, placing the resultant assembly under vacuum, and immersing the assembly in a bath of the liquid crystal, so that the liquid crystal flows through the aperture between the backplane and the front electrode. Finally, with the liquid crystal in place, the aperture is sealed to provide the final display.

**[Para 17]** This LCD assembly process cannot readily be transferred to solid electro-optic displays. Because the electro-optic material is solid, it must be present between the backplane and the front electrode before these two integers are secured to each other. Furthermore, in

contrast to a liquid crystal material, which is simply placed between the front electrode and the backplane without being attached to either, a solid electro-optic medium normally needs to be secured to both; in most cases the solid electro-optic medium is formed on the front electrode, since this is generally easier than forming the medium on the circuitry-containing backplane, and the front electrode/electro-optic medium combination is then laminated to the backplane, typically by covering the entire surface of the electro-optic medium with an adhesive and laminating under heat, pressure and possibly vacuum. Accordingly, most prior art methods for final lamination of solid electrophoretic displays are essentially batch methods in which (typically) the electro-optic medium, a lamination adhesive and a backplane are brought together immediately prior to final assembly, and it is desirable to provide methods better adapted for mass production.

**[Para 18]** Electro-optic displays are often costly; for example, the cost of the color LCD found in a portable computer is typically a substantial fraction of the entire cost of the computer. As the use of electro-optic displays spreads to devices, such as cellular telephones and personal digital assistants (PDA's), much less costly than portable computers, there is great pressure to reduce the costs of such displays. The ability to form layers of some solid electro-optic media by printing techniques on flexible substrates, as discussed above, opens up the possibility of reducing the cost of electro-optic components of displays by using mass production techniques such as roll-to-roll coating using commercial equipment used for the production of coated papers, polymeric films and similar media.

**[Para 19]** The aforementioned U.S. Patent No. 6,982,178 describes a method of assembling a solid electro-optic display (including an encapsulated electrophoretic display) which is well adapted for mass production. Essentially, this patent describes a so-called "front plane laminate" ("FPL") which comprises, in order, a light-transmissive electrically-conductive layer; a layer of a solid electro-optic medium in electrical contact with the electrically-conductive layer; an adhesive layer; and a release sheet. (The term "light-transmissive" is used in this patent and herein to mean that the layer thus designated transmits sufficient light to enable an observer, looking through that layer, to observe the change in display states of the electro-optic medium, which will normally be viewed through the electrically-conductive layer and adjacent substrate (if present); in cases where the electro-optic medium displays a change in reflectivity at non-visible wavelengths, the term "light-transmissive" should of course be interpreted to refer to transmission of the relevant non-visible wavelengths.) Typically, the light-transmissive electrically-conductive layer will be carried on a light-transmissive

substrate, which is preferably flexible, in the sense that the substrate can be manually wrapped around a drum (say) 10 inches (254 mm) in diameter without permanent deformation. The substrate will typically be a polymeric film, and will normally have a thickness in the range of about 1 to about 25 mil (25 to 634  $\mu\text{m}$ ), preferably about 2 to about 10 mil (51 to 254  $\mu\text{m}$ ). The electrically-conductive layer is conveniently a thin metal or metal oxide layer of, for example, aluminum or ITO, or may be a conductive polymer. Poly(ethylene terephthalate) (PET) films coated with aluminum or ITO are available commercially, for example as "aluminized Mylar" ("Mylar" is a Registered Trade Mark) from E.I. du Pont de Nemours & Company, Wilmington DE, and such commercial materials may be used with good results in the front plane laminate.

**[Para 20]** Assembly of an electro-optic display using such a front plane laminate may be effected by removing the release sheet from the front plane laminate and contacting the adhesive layer with the backplane under conditions effective to cause the adhesive layer to adhere to the backplane, thereby securing the adhesive layer, layer of electro-optic medium and electrically-conductive layer to the backplane. This process is well-adapted to mass production since the front plane laminate may be mass produced, typically using roll-to-roll coating techniques, and then cut into pieces of any size needed for use with specific backplanes.

**[Para 21]** U.S. Patent No. 7,561,324 describes a so-called "double release sheet" which is essentially a simplified version of the front plane laminate of the aforementioned U.S. Patent No. 6,982,178. One form of the double release sheet comprises a layer of a solid electro-optic medium sandwiched between two adhesive layers, one or both of the adhesive layers being covered by a release sheet. Another form of the double release sheet comprises a layer of a solid electro-optic medium sandwiched between two release sheets. Both forms of the double release film are intended for use in a process generally similar to the process for assembling an electro-optic display from a front plane laminate already described, but involving two separate laminations; typically, in a first lamination the double release sheet is laminated to a front electrode to form a front sub-assembly, and then in a second lamination the front sub-assembly is laminated to a backplane to form the final display, although the order of these two laminations could be reversed if desired.

**[Para 22]** U. S. Patent No. 7,839,564 describes a so-called "inverted front plane laminate", which is a variant of the front plane laminate described in the aforementioned U.S. Patent No. 6,982,178. This inverted front plane laminate comprises, in order, at least one of a light-transmissive protective layer and a light-transmissive electrically-conductive layer; an adhesive layer; a layer of a solid electro-optic medium; and a release sheet. This inverted front

plane laminate is used to form an electro-optic display having a layer of lamination adhesive between the electro-optic layer and the front electrode or front substrate; a second, typically thin layer of adhesive may or may not be present between the electro-optic layer and a backplane. Such electro-optic displays can combine good resolution with good low temperature performance.

**[Para 23]** Electrophoretic and similar bistable electro-optic display media have until now been primarily used in electronic document readers (E-book readers), with some use in electronic storage media such as flash drives, portable computers, tablet computers, cellular telephones, smart cards, signs, watches, shelf labels, and variable transmission windows. However, the low power requirements, flexibility and light weight of electrophoretic and similar bistable electro-optic display media render them useful in numerous other applications, especially architectural and related applications.

**[Para 24]** The aforementioned US 2016/0259225 describes several application of electrophoretic displays in architectural application, especially color-changing tiles and other means of changing the color of room décor to alter the mood of a room. The aforementioned US 2016/0232835 describes driving method for electrophoretic displays which are particularly useful for large area displays, such as in furniture and architectural applications.

**[Para 25]** The term “architectural surface” is used herein to denote a surface of a building or similar structure, for example, a portable building, travel trailer or recreational vehicle, whether internal or external, although the inventions described below are likely to be used mainly on internal surfaces. The term “architectural surface” is also intended to include surfaces of architectural fixtures, and movable or permanent structures, such a room dividers, which act as temporary or permanent walls within buildings. Thus, the term “architectural surface” includes not only walls, ceilings and floors of buildings and similar structures, but surfaces of, for example, kitchen cabinets, appliances and islands, and the surfaces of doors, .screens and room dividers.

**[Para 26]** As discussed in detail in the aforementioned US 2016/0259225, electro-optic displays, especially bistable electro-optic displays, open up novel possibilities for the treatment of architectural surfaces which allow for variation of the appearance of the surface, including patterning or displaying images on architectural surfaces; in effect, entire walls (or other similar surfaces, such as ceilings and room partitions or dividers) can become displays. Such “wall displays” may be useful in rooms used for multiple functions (such as hotel and similar function rooms) only a small proportion of which require large visual displays. In such cases, the cost

of a large monitor may be difficult to justify and the appearance of the monitor when not in use (for the majority of the time the function room is used) may be objectionable. Similarly, the cost of a large, retractable projection screen and associated driving apparatus may be difficult to justify. Ideally, in such situations one would like have a large area of wall or similar surface which can be used to display images when required but which simply appears as a conventional wall surface when not in use for displaying images. The present invention seems to provide such a wall display.

**[Para 27]** Although present technology is capable of providing very large areas of electrophoretic and other display media, if necessary by joining parallel strips of such media, the major difficulty in providing large, high resolution displays is finding a way to drive the display. To a large extent, the complexity and cost of current display solutions have limited this type of application. To create a high resolution image on a large display area currently requires either an active matrix backplane or a passive matrix display, either of which requires complex electrical connections and a large number of drive signals; especially on an architectural scale, which could involve displays of 100 square feet (about 10 square meters) or more, the cost of any current active matrix or passive matrix display would be prohibitive for most applications. The present invention seeks to provide method of driving an architectural scale display in an economical manner.

**[Para 28]** Another aspect of the present invention relates to color adjustment on walls and similar architectural surfaces. It is notoriously difficult for most “laymen” (in this context, meaning those who are not skilled in color science) to select paints and other coloring materials (for example, floor, wall or ceiling tiles) to produce a desired effect in a room. Traditionally, retail stores provide small samples (“swatches”) of colors available in the paints they sell. Even if the swatches accurately represent the paint colors (and the differences between pigment-based paints and dye-based printing make exact matching difficult), viewing a small swatch in a large retail store under artificial illumination usually different from that used in homes, and surrounded by a palette of colors (for example, gray concrete floors, red or yellow metal racks and gray ceilings) bearing no resemblance to that typically present in a home, is likely to leave most layman choosing a paint color differing markedly from that they really want. Even if the customer takes a limited number of swatches home to evaluate them *in situ*, at least two major problems remain. Some colors may be perceived very differently depending upon whether they are illuminated with natural or artificial light, and the color perceived in natural light may vary considerable depending upon whether the natural light is the white light of noon or the more

roseate light near dawn or dusk, and customers frequently fail to test the swatches under varying lighting conditions. Furthermore, because of the structure of the human eye, in which the color-perceiving cones are concentrated in the central area, with a preponderance of color-insensitive rods on the periphery, human color perception varies with the size of the color sample being viewed; there is a significant difference between so-called 2° color (in which the color sample subtends 2 degrees of arc as seen by the eye) and 10° color. In particular, pale (relatively unsaturated colors) tend to appear more saturated when large expanses of color are being viewed.

**[Para 29]** In an effort to reduce these problems, many paint stores now sell small samples of paint, enough to paint about one or two square feet of wall, so that customers can test various colors before making their final choice. However, buying and applying several paint samples involves significant expense and labor, and the appearance of a sample patch, which will typically be viewed against a background of the existing wall color, may still not accurately reflect the appearance of an entire wall of the same color; for example, a pale blue patch viewed against an existing yellow background may appear somewhat more saturated than the final pale blue wall, while a purple patch viewed against a red background will appear shifted towards blue. Furthermore, leaving several different patches of color on a wall may cause problems after later repainting, since the various colors may tend to show through the final color, leaving either a non-uniform final color or requiring an extra coat of paint to overcome the show through colors.

**[Para 30]** The result of all the aforementioned problems is that when it comes to selecting colors for indoor architectural features, most people find selecting the correct color to be a daunting task. Often, people have a particular hue or tone in mind but are disappointed by the appearance of their painting (or other color application, such as floor tiling), and their disappointment is increased by the fact repainting is the only corrective action available.

**[Para 31]** Furthermore, for reasons discussed in more detail in the aforementioned US 2016/0259225, it may be desirable to vary the color of architectural surfaces to allow for changes in the use of a room (for example, warm colors tend to be more appropriate for friendly social gatherings, whereas cool colors may be more appropriate for study) or changes in lighting conditions, time of day or season of year, etc.

**[Para 32]** The present invention seeks to provide a treatment for architectural surfaces which reduces or overcomes the problems discussed above, and allows adjustment of the appearance of the surface without repainting.

**[Para 33]** In one aspect, this invention provides a method of forming an image on an architectural surface, the method comprising:

applying to the architectural surface, in order:

a rear electrode layer;

a light-transmissive front electrode layer;

a photoconductive layer disposed between the front and rear electrode layers;

and

an electro-optic layer disposed between the front and rear electrode layers;

applying a potential difference between the front and rear electrode layers; and

imagewise exposing the front electrode layer to radiation effective to cause a change in the conductivity of the photoconductive layer, thereby causing an imagewise change in the optical state of the electro-optic layer.

**[Para 34]** In this image-forming method, the photoconductive layer and the electro-optic layer may be arranged in either order between the two electrode layers. Typically, the photoconductive layer will be arranged between the electro-optic layer and the rear electrode because many photoconductive layers are either opaque or strongly colored, and hence would distort the color of the electro-optic layer as viewed by an observer seeing this layer through the front electrode. However, if the photoconductive layer used is substantially transparent, or colored in a manner which is not objectionable to the observer (for example, a yellow photoconductive layer in front of a black-white electro-optic layer might be used to provide a black-yellow display), the photoconductive layer may be disposed between the electro-optic layer and the front electrode (i.e., in front of the electro-optic layer). If the electro-optic layer strongly absorbs the radiation used for the imagewise exposure, it may be necessary to dispose the photoconductive layer in front of the electro-optic layer. Note that although the image produced will normally need to be visible to the human eye, there is no requirement that the radiation used for the imagewise exposure be visible; indeed, in some cases it may be convenient to use non-visible radiation (for example, near ultra-violet radiation) so as to allow for the formation of an image without any visible projection beam.

**[Para 35]** In one form of this method, the imagewise exposure is effected by projecting an image on to the architectural surface using a projector. Alternatively, particularly where the space in front of the architectural surface is limited, the imagewise exposure could be effected by passing a row of light emitters (for example, a strip of light emitting diodes) over the architectural surface; although this method is likely to be much slower than projecting the

whole image at once, it may be acceptable in many architectural applications, where images may only be changed at lengthy intervals. If desired, the row of light emitters could be static along one edge of the display and a moving angled mirror could be used to direct light from the light emitters on to the display itself.

**[Para 36]** In the image forming method of the present invention, the stack provided on the architectural surface may include additional layers. In particular, the stack may include an additional adhesive layer between the front electrode layer and the electro-optic layer and/or between the electro-optic layer and the rear electrode layer. The film may also include a protective layer on the opposed side of the front electrode layer from the electro-optic layer. The film may also include any of the optional features of front plane laminates, inverted front plane laminates or double release films in the patents and applications discussed above.

**[Para 37]** In another aspect, this invention provides a film for application to an architectural surface, the film comprising, in order:

a light-transmissive colored front electrode layer;

an electro-optic layer;

a rear electrode layer; and

an adhesive layer,

the film being provided with at least one front connecting means for connecting the front electrode layer to a first conductor placed on the architectural surface and/or the front electrode layer of an adjacent film, and also being provided with at least one rear connecting means for connecting the rear electrode layer to a second conductor placed on the architectural surface and/or the rear electrode layer of an adjacent film.

**[Para 38]** The light-transmissive colored front electrode layer may be a single layer of, for example, a dyed conductive polymer, such as a polythiophene. However, some common types of light-transmissive electrodes, for example sputtered metal oxides such as indium tin oxide, are not readily available in colored form, and in such cases it will generally be convenient to provide the light-transmissive colored front electrode layer as a double layer, with the conductive layer closer to the electro-optic layer and a separate colored layer on the opposed side of the conductive layer from the electro-optic layer.

**[Para 39]** There are two main variants of the film of the present invention. In the first variant, the electro-optic layer is a black-and-white film (i.e., one having black and white extreme states, and typically a number of gray states intermediate the black and white extreme states).



This film variant allows one to alter the color tone of the architectural surface by modulating the reflectivity of the electro-optic layer behind the light-transmissive colored layer. In the second variant, the electro-optic layer is capable of displaying at least two different colors, so that one can alter the hue, and preferably also the tone, of the architectural surface by modulating the color (and preferably reflectivity) of the electro-optic layer.

**[Para 40]** The films of the present invention may have a variety of physical forms. When used on walls or similar vertical surfaces they may be in the form of long rolls which can be applied to the vertical surfaces in the same manner as conventional wallpaper. (In this case, provided that appropriate moisture barriers are provided to protect the electrode layers and the electro-optic layer, the adhesive layer may be of the water-activated type so that the film can be applied in the same manner as pre-pasted wallpaper.) Films intended to application to horizontal surfaces, such as countertops and ceilings, may also be in the form of rolls. Films intended for application to floors may be in the form of tiles, in which case it may be convenient to form the front and rear connecting means as edge connectors on each tile to make contact with adjacent tiles to allow multiple tiles to switch simultaneously.

**[Para 41]** The adhesive layer will typically be a pressure-sensitive adhesive, in which case the adhesive layer will normally need to be covered with a release sheet to prevent unwanted adhesion of the adhesive to other materials during transit, including other portions of the film if a long film is rolled during storage or transit. However, other types of adhesive may be used. For example, in some types of tiles intended for application to a relatively rough sub-floor, it may be desirable to a flowable heat-activated adhesive and expose the tiles to an appropriate temperature immediately prior to contacting them with the sub-floor. Also, as previously noted, water-activated adhesives may be used.

**[Para 42]** The front and rear connecting means (hereinafter “front and rear connectors”) may also have a variety of physical forms. In the case of films applied in the same manner as wallpaper, it will generally be convenient to supply operating voltages to the front and rear electrodes via two horizontal conductors running adjacent the upper and lower edges of the portion of the wall to which the film is to be applied. The front and rear connectors can then have the form of extensions of the front and rear electrode layers extending laterally beyond one or both lateral edges of the film and making electrical contact with horizontal conductors either directly or via conductive adhesives. Such front and rear connectors may be hidden behind adjacent pieces of film, and to prevent electrical short circuits it may be desirable to cover the exposed surfaces of the extensions with an insulating layer. Instead of providing an

extension of the rear electrode layer, direct electrical contact may be effected between the rear electrode layer and an underlying conductor by, for example, doping a portion of the adhesive layer to render it sufficiently conductor (see United States Patent No. 7,012,735 for dopants for increasing the conductivity of adhesives, removing a portion of the adhesive layer, and optionally replacing it with a conductive adhesive, or using a conductor with a rough surface and pressing the film on to the conductor until projections on the rough surface make contact with the rear electrode layer.

**[Para 43]** The film of the present invention may include additional layers. In particular, the film may include an additional adhesive layer between the front electrode layer and the electro-optic layer and/or between the electro-optic layer and the rear electrode layer. The film may also include a protective layer on the opposed side of the light-transmissive colored layer from the electro-optic layer (or the light-transmissive colored layer may also be configured to act as a protective layer to protect the remaining layers of the display from mechanical damage). The film may also include any of the optional features of front plane laminates, inverted front plane laminates or double release films in the patents and applications discussed above.

**[Para 44]** In another aspect, this invention provides a method of coating an architectural surface, the method comprising:

- providing a film of the present invention having a release sheet;
- removing the release sheet from the film; and
- applying the film, less the release sheet, to an architectural surface.

**[Para 45]** In another aspect this invention provides an architectural surface provided with spaced first and second conductors, and a plurality of pieces of a film of the present invention adhered to the architectural surface, with the front connecting means of each of the plurality of pieces electrically connected to the first conductor and the rear connecting means of each of the plurality of pieces electrically connected to the second conductor.

**[Para 46]** Some electro-optic layers used in the films of the present invention (and in the structures used in the image-forming method of the present invention), especially electrophoretic films, typically contain inflammable organic fluids, and may also contain polymeric films capable of ignition. Accordingly, at least some jurisdictions may require the exposed surfaces of the films to be provided with an intumescent (fire-resistant) coating. Many conventional intumescent coatings are essentially opaque and thus unsuitable for use with films of the present invention. If a film of the present invention or an image-receiving surface used in the method of the present invention requires an intumescent coating. These intumescent

coatings may comprise a layer of an intumescent material and at least one moisture barrier in contact with at least one surface of the layer of intumescent material, the intumescent material comprising an amine or amide containing compound. The intumescent material may be provided with first and a moisture barriers, with the intumescent material disposed between the first and second moisture barriers. The or each moisture barrier may comprise a protective film and a layer of adhesive. The protective film may comprise a material selected from the group consisting of polyethylene terephthalate, polyethylene naphthalate, polycarbonate, polyimides, cyclic olefin homopolymers or copolymers, and combinations thereof. The layer of adhesive may comprise an optically clear adhesive material. The moisture barrier may have has a water vapor transmission rate (WVTR) less than or equal to 0.01 g/m<sup>2</sup>/day at 60 °C and 100% relative humidity. The intumescent material may include a char-forming carbonaceous material, a dehydration catalyst, and a blowing agent. The char-forming carbonaceous material may be selected from the group consisting of polyols, polyamide-6, nanocomposites of polyamide-6 and clay, triazine derivatives, isocyanurate derivatives, ethanolamine-aminotriazine oligomers, and combinations thereof. The dehydration catalyst may be selected from the group consisting of ammonium polyphosphate, ammonium pyrophosphate, melamine phosphate, melamine pyrophosphate, melamine polyphosphate, chloroalkyl phosphates, chloroalkyl phosphonates, esters of organic phosphates or phosphonates, and combinations thereof. The blowing agent may be selected from the group consisting of melamine, triazine derivatives, and combinations thereof. The intumescent material may also comprise a binder resin, which may be selected from the group consisting of melamine formaldehyde, urea formaldehyde, polyacrylates, polyurethanes, polyvinyls, EVAs, PVAc, epoxides, silicates, and combinations thereof. The intumescent material may also comprise a plasticizer, which may be selected from the group consisting of glycerol and ethylene glycol. At least a portion of the layer of intumescent material will normally be located between the at least one moisture barrier and the layer of electro-optic material.

**[Para 47]** Figure 1 is a schematic cross-section through a film used in the image-forming method of the present invention.

**[Para 48]** Figure 2 is a perspective view showing the image-forming method of the present invention being carried out using a projector.

**[Para 49]** Figure 3 is a schematic cross-section through a film of the present invention applied to a wall.

[Para 50] Figure 4 is a schematic front elevation showing two pieces of the film shown in Figure 3 applied to a wall provided with two conductors.

[Para 51] Figures 5A and 5B are schematic cross-sections, similar to those of Figure 3, showing two different optical states of a color film of the present invention applied to a wall.

[Para 52] Specific embodiments of the present invention will now be described in more detail, though by way of illustration only, with reference to the accompanying drawings.

**[Para 53] Part A: Image-forming method of the present invention**

[Para 54] As already mentioned, in one aspect the present invention provides a method of forming an image on an architectural surface, the method comprising applying to the architectural surface, in order: a rear electrode layer; a light-transmissive front electrode layer; a photoconductive layer disposed between the front and rear electrode layers; and an electro-optic layer disposed between the front and rear electrode layers; applying a potential difference between the front and rear electrode layers; and imagewise exposing the front electrode layer to radiation effective to cause a change in the conductivity of the photoconductive layer, thereby causing an imagewise change in the optical state of the electro-optic layer.

[Para 55] The image-forming method of the present invention is designed to allow architectural sized (100 square foot, 10 square meter, or larger) high resolution images to be produced using unpatterned display media (i.e., with only two simple continuous electrodes, rather than a matrix of electrodes defining the pixels of the display) and no embedded electronic drivers. Essentially, the present invention solves this problem by inserting a layer of photoconductive material between the electrodes of an electro-optic display, thus forming a dual stimulus device, the stimuli being electric field and radiation, such that the display medium is addressed only when both stimuli are present.

[Para 56] Figure 1 is a schematic cross-section through a film (generally designated 100) useful in the image-forming method of the present invention. The film 100 comprises a protective layer 102 (which may be omitted depending upon the materials used for the remaining layers of the film), a light-transmissive continuous front electrode layer 104, an electro-optic layer 106 (illustrated as a dual particle encapsulated electrophoretic layer), a lamination adhesive layer 108, a photoconductive layer 110 and a continuous rear electrode layer 112. Note that the photoconductive layer 110 is disposed between the electrode layer 104 and the rear electrode layer 112, and that the reference to “continuous” electrode layers does not preclude multiple electrodes being used in large displays; indeed, given that some light-transmissive electrode layers, for example sputtered metal oxides, have relatively high

resistance, it may be desirable to break the electrode layers of very large displays into multiple segments not larger than (say) 600 mm square to avoid slow switching due to electrode resistance.

**[Para 57]** Figure 2 illustrates the image-forming method of the present invention being effected using the display of Figure 1, in the form of large screen 200 (or even an entire wall of a room, if desired). A projector 202, which is conveniently of the type which passes light up through a transparency 204 and then deflects the light horizontally by means of an angled mirror assembly 206, is used to project an image of the transparency 204 on to the screen 200. There is applied between the electrode layers 104 and 112 (Figure 1) a potential difference having a magnitude and polarity sufficient to drive the screen 200 from black to white provided the photoconductive layer 110 is in its conductive state. The screen 200 is initially set to solid black. In areas where no light reaches the screen 200, the resistance of the photoconductive layer 110 remains high, and the screen remains black. However, in areas where light reaches the screen 200, the photoconductive layer 110 becomes conductive and essentially the whole potential difference between the electrode layers is applied across the electro-optic layer 106, thereby causing these areas to change from black to white (or from black to varying shades of gray, depending upon the specific electro-optic medium used), and reproducing on the screen the image on the transparency 204.

**[Para 58]** When it is desired to produce a different image on the screen 200, the screen may be erased by removing the transparency 204 from the projector 202, thus allowing the entire area of the screen to be illuminated (and the entire photoconductive layer 110 thus rendered conductive), and applying between the electrode layers 104 and 112 a potential difference having a magnitude and polarity sufficient to drive the entire screen black. In practice, to avoid certain “memory” or “ghosting” effects common in certain electro-optic displays, it may be advisable to drive the entire screen from black to white and back again several times by reversing the polarity of the potential difference between the electrode layers 104 and 112.

**[Para 59]** It will be appreciated that the resolution of the image provided on the screen 200 is limited only by the resolution of the image provided by the projector 202, and any of the commercially known methods for the creation of high resolution projected images (for example, LCD projectors driven by computers) can be used. It is not essential to start image formation from a black screen; one could start from a white screen and drive the exposed areas to black (or to black and intermediate shades of gray), but note that in this case the final image would be a negative of the transparency 204.

**[Para 60]** The film shown in Figure 1 can readily be produced by a modification of the front plane laminate production process described in the aforementioned United States Patent No. 6,982,178. The electro-optic medium can be coated on the front electrode layer in the usual manner. Separately, the photoconductive layer is formed on the rear electrode layer, and the lamination adhesive layer coated over the photoconductive layer. The rear electrode/photoconductive layer/adhesive layer sub-assembly can then be laminated to the sub-assembly containing the electro-optic layer in the usual way.

**[Para 61]** The film used in the image-forming method of the present invention may be provided with a second adhesive layer and a release sheet on the opposed side of the rear electrode layer from the electro-optic layer to facilitate attachment of the film to an architectural surface, in the same manner as already described for the films of the present invention.

**[Para 62]** From the foregoing it will be seen that the image-forming method of the present invention allows high resolution addressing of large architectural displays using simple media with unpatterned electrodes. Also, using projected light to form the image makes the driving method simple and inexpensive.

**[Para 63] Part B: Films for varying appearance of architectural surfaces**

**[Para 64]** As already mentioned, in one aspect this invention provides a film for application to an architectural surface, the film comprising, in order: a light-transmissive colored layer; a light-transmissive front electrode layer; an electro-optic layer; a rear electrode layer; an adhesive layer; and a release sheet. This film is intended to be applied to an architectural surface by peeling the release sheet from the remaining layer of the film and contacting the adhesive layer (after any necessary activation, such as heating, if required) with the architectural surface, thereby securing the film (less the release sheet) to the architectural surface.

**[Para 65]** Figure 3 is a schematic cross-section through a variable tone film (generally designated 300) of the present invention applied to a wall 302. The film 300 comprises a light-transmissive colored layer 304, having the form of a receiver film with a painted, light-transmissive colored overlay. The colored layer 304 is fixed to a light-transmissive front electrode layer 306, which is in contact with an electro-optic layer 308, illustrated as an encapsulated electrophoretic medium comprising black and white particles dispersed in a colorless fluid. On the opposed side of the electro-optic layer 308 from the front electrode layer 306 are a rear electrode layer 310 and a lamination adhesive layer 312, which is in direct contact with the wall 302. Prior to being applied to the wall 302, the film 300 also comprised a release

sheet (not shown) covering the lamination adhesive layer 312; this release sheet was of course removed to enable the lamination adhesive layer 312 to adhere to the wall 302.

**[Para 66]** As will be apparent from the foregoing description, the film 300 may be produced by first producing a front plane laminate (FPL) as described in the aforementioned U.S. Patent No. 6,982,178, starting from a film comprising the colored layer 304 and the front electrode layer 306. Separately, the lamination adhesive layer 312 is coated on to the release sheet, and the resultant adhesive layer/release sheet sub-assembly laminated to the rear electrode layer of the FPL to produce the final film. Such a process will leave an “extra” adhesive layer between the electro-optic layer 308 and the rear electrode layer 310 but such an extra adhesive layer is not objectionable provided it has the appropriate conductivity. Obviously, various other processes may be used to form the film 300. In particular, since the rear electrode layer 310 is planar, the electro-optic layer 308 could be coated on to the rear electrode 310, and thereafter a sub-assembly comprising the colored layer 304, front electrode layer 306 and a lamination adhesive layer could be laminated to the exposed electro-optic layer 308. Such a process will leave an “extra” adhesive layer between the electro-optic layer 308 and the front electrode layer 306 but such an extra adhesive layer is not objectionable provided it has the appropriate conductivity. This process has the advantage of avoiding subjecting the colored layer 304 to the elevated temperatures typically required to dry the electro-optic layer 308 when that layer is an encapsulated electrophoretic medium.

**[Para 67]** The colored layer 304 may be produced by applying a transmissive color overlay on to a receiver film. Alternatively, a transmissive color gel could be applied to the viewing surface of the front electrode layer shown in Figure 3.

**[Para 68]** Figure 4 is a front elevation of a wall (generally designated 400) having upper and lower horizontal conductors 402 and 404 mounted thereon; these conductors may be in the form of metal tapes provided on their rear surfaces (as illustrated in Figure 4) with a pressure-sensitive adhesive by means of which they are attached to the wall. The conductors 402 and 404 are both connected to a display driver (not shown).

**[Para 69]** Also mounted on the wall 400 are two strips 406, 408 of the film shown in Figure 3. (It will be appreciated that normally more than two strips would be used, but Figure 4 is simplified for ease of illustration.) Each strip 406, 408 is provided at its upper end with a rear connector 410 in electrical contact with the rear electrode of the strip. Each rear connector 410 has the form of a tab extending horizontally from the upper part of the left-hand edge (as illustrated in Figure 4) of the strip 406, 408 and overlying the upper conductor 402. Electrical

contact is made between the connector 410 and the conductor 402 by pressing the two into contact, although an electrically conductive adhesive may be used if desired. Similarly, each strip 406, 408 is provided at its lower end with a front connector 412 similar in form to the rear connector 410 but in electrical contact with the front electrode of the strip and with the lower conductor 404. Note that the strip 406 is arranged to cover and thus hide the connectors 410, 412 of strip 408. To prevent accidental short circuits, the front surfaces of the connectors 420, 412 are covered with an insulating layer (not shown). Thus, when a plurality of strips of film are arranged adjacent each other to cover a wall in a manner similar to conventional wallpaper, only one pair of connectors 410, 412 are exposed, and this exposed pair may be covered by a decorative edge molding.

**[Para 70]** To allow for variations in the positions of the conductors 402, 404 (which need not be along the ends of the strips 406, 408 but can occupy intermediate positions) it may be desirable to provide the strip with multiple sets of connectors 410, 412 spaced from one another. Alternatively, the connectors 410, 412 can have a greater vertical dimension than illustrated in Figure 4, in which case it may be desirable to trim off excess connector not in contact with the one of the conductors 402, 404. It may be convenient to provide lines of weakness (for example, by rouletting) in the conductors to facilitate removal of excess material.

**[Para 71]** In some cases, it may be advantageous to provide multiple sets of conductors 402, 404 on the wall, with corresponding multiple sets of connectors 410, 412. Such multiple sets of conductors and connectors can provide useful redundancy to enable the film to continue operating even if one contact fails. Multiple sets of conductors and connectors spaced from one another may also be useful to produce interesting visual effects in the film in the manners described in US 2016/0232835 and US 2018/0136532.

**[Para 72]** Figure 5A is a schematic cross-section, similar to that of Figure 3 but showing a variable hue film (generally designated 500) of the present invention applied to a wall 502. The film 500 comprises a light-transmissive colored layer 304, a light-transmissive front electrode layer 306, a rear electrode layer 310 and a lamination adhesive layer 312, all of which are essentially identical to the corresponding layers of the film 300 shown in Figure 3. Prior to being applied to the wall 502, the film 500 also comprised a release sheet (not shown) covering the lamination adhesive layer 312; this release sheet was of course removed to enable the lamination adhesive layer 312 to adhere to the wall 502.

**[Para 73]** However, the film 500 differs from the film 300 in that its electro-optic layer 508 is an encapsulated electrophoretic medium switchable between a white and a magenta state.



Figure 5A illustrates the film 500 with the electro-optic layer 508 in its white state (as seen from the exposed surface of the film 500). This white state causes the film to display the yellow color of the colored layer 304. Figure 5B on the other hand illustrates the film 500 with the electro-optic layer 508 in its magenta state. As will be apparent to anyone skilled in color science, the transmissive yellow color of the colored layer 304 absorbs blue light, while the magenta pigment absorbs green light, so the superimposition of the two colors causes the film 500 to display a red color. It will readily be apparent to those skilled in color science that variation of the colors of the colored layer 304 and the pigments in the electro-optic layer 508 will enable a variety of color transitions to be effected by the variable hue films of the present invention. Furthermore, the present invention is not limited to the use of bichromal (two color) electro-optic layers; the aforementioned patents and published applications describe tri- and tetrachromal electrophoretic media capable of being driven by a simple pair of electrodes such as layers 306 and 310 in Figures 5A and 5B, and such tri- and tetrachromal electrophoretic media can be used in the films of the present invention to produce complex color transitions.

**CLAIMS**

1. A method of forming an image on an architectural surface (200), the method being characterized by:

applying to the architectural surface (200), in order:

a rear electrode layer (112);

a light-transmissive front electrode layer (104);

a photoconductive layer (110) disposed between the front (104) and rear (112) electrode layers; and

an electro-optic layer (106) disposed between the front (104) and rear (112) electrode layers;

applying a potential difference between the front (104) and rear (112) electrode layers; and

imagewise exposing the front electrode layer (104) to radiation effective to cause a change in the conductivity of the photoconductive layer (110), thereby causing an imagewise change in the optical state of the electro-optic layer (106).

2. A method according to claim 1 wherein the photoconductive layer (110) is disposed between the electro-optic layer (106) and the rear electrode layer (112).

3. A method according to claim 1 wherein the imagewise exposure is effected by projecting an image on to the architectural surface (200) using a projector (202).

4. A method according to claim 1 wherein the imagewise exposure is effected by providing a plurality of light emitters adjacent the architectural surface (200) and moving the light from the light emitters across the architectural surface (200).

5. A method according to claim 1 wherein the layers applied to the architectural surface further comprise at least one of:

(a) an adhesive layer between the front electrode layer and the electro-optic layer;

(b) an adhesive layer (108) between the electro-optic layer (106) and the rear electrode layer (112); and

(c) a protective layer (102) on the opposed side of the front electrode layer (104) from the electro-optic layer (106).

6. A method according to claim 1 wherein the electro-optic layer (106) is an electrophoretic layer.

7. A method according to claim 1 wherein the layers applied to the architectural surface further comprise an intumescent coating on the opposed side of the front electrode layer from the electro-optic layer.

8. A method according to claim 7 wherein the intumescent coating comprises a layer of an intumescent material and at least one moisture barrier in contact with at least one surface of the layer of intumescent material, the intumescent material comprising an amine or amide containing compound.

9. A film (300, 406, 408) for application to an architectural surface (302, 400), the film (300, 406, 408) being characterized by, in order:

a light-transmissive colored front electrode layer (304, 306);

an electro-optic layer (308);

a rear electrode layer (310); and

an adhesive layer (312),

the film (300, 406, 408) being provided with at least one front connecting means (412) for connecting the front electrode layer (304, 306) to a first conductor (404) placed on the architectural surface (302, 400) and/or the front electrode layer of an adjacent film (304, 306), and also being provided with at least one rear connecting means (410) for connecting the rear electrode layer (310) to a second conductor (402) placed on the architectural surface (302, 400) and/or the rear electrode layer (310) of an adjacent film (300, 406, 408).

10. A film according to claim 9 further comprising a release sheet covering the surface of the adhesive layer (312) remote from the rear electrode layer (310).

11. A film according to claim 9 wherein the light-transmissive colored front electrode layer (304, 306) comprises a conductive layer (306) adjacent the electro-optic layer (308) and a colored layer (304) on the opposed side of the conductive layer (306) from the electro-optic layer (308).

12. A film according to claim 9 wherein the front (412) and rear (410) connecting means have the form of extensions of the front (304, 306) and rear (310) electrode layers extending laterally beyond one or both lateral edges of the film (300, 406, 408).

13. A film according to claim 1 further comprising at least one of:

(a) an adhesive layer between the front electrode layer and the electro-optic layer;

(b) an adhesive layer between the electro-optic layer and the rear electrode layer; and

(c) a protective layer on the opposed side of the front electrode layer from the electro-optic layer.

14. A film according to claim 9 wherein the electro-optic layer (308) is an electrophoretic layer.

15. A film according to claim 9 further comprising an intumescent coating on the opposed side of the front electrode layer from the electro-optic layer.

16. A film according to claim 15 wherein the intumescent coating comprises a layer of an intumescent material and at least one moisture barrier in contact with at least one surface of the layer of intumescent material, the intumescent material comprising an amine or amide containing compound.

17. A method of coating an architectural surface (302, 400), the method comprising:

providing a film (300, 406, 408) according to claim 10;

removing the release sheet from the film (300, 406, 408); and

applying the film (300, 406, 408), less the release sheet, to the architectural surface (302, 400).

18. An architectural surface (400) provided with spaced first (404) and second (402) conductors, and a plurality of pieces (406, 408) of a film according to claim 9 adhered to the architectural surface (400), with the front connecting means (412) of each of the plurality of pieces (406, 408) electrically connected to the first conductor (404) and the rear connecting means (410) of each of the plurality of pieces (406, 408) electrically connected to the second conductor (402).

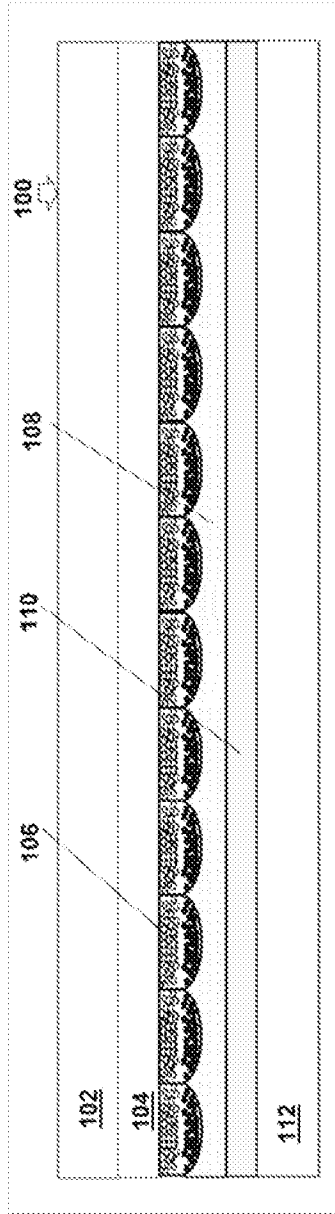

Fig. 1

2/5

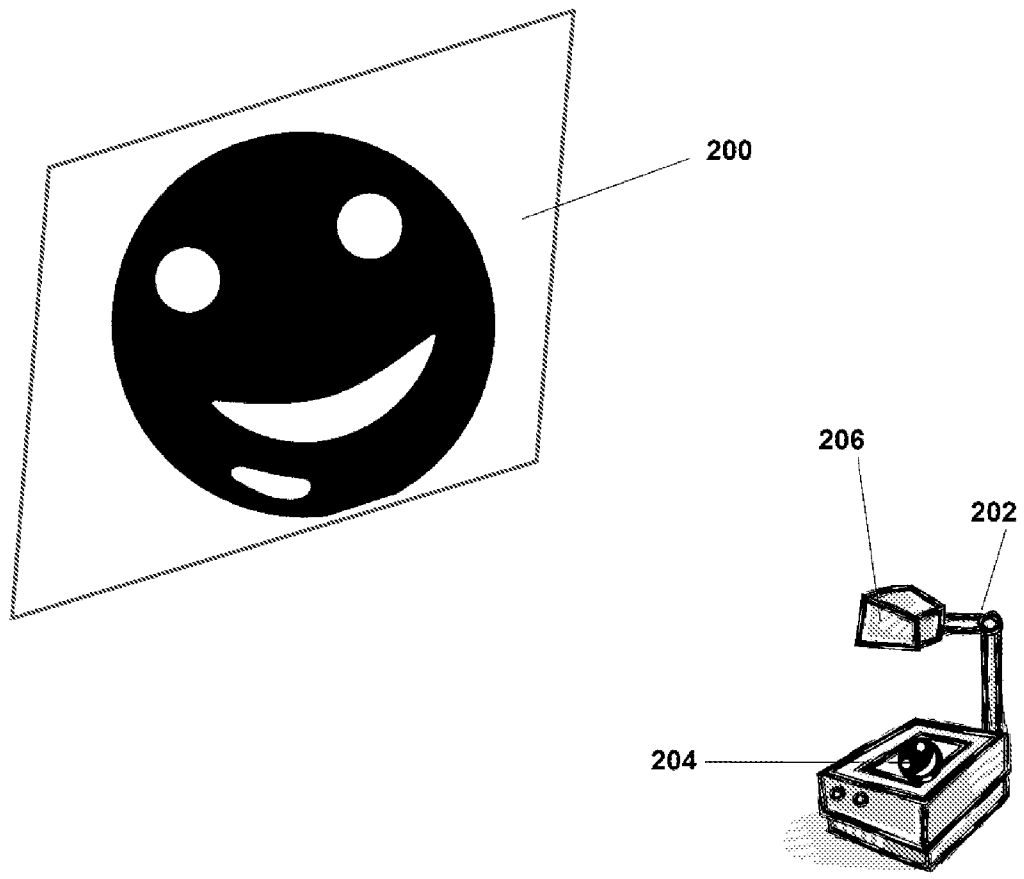
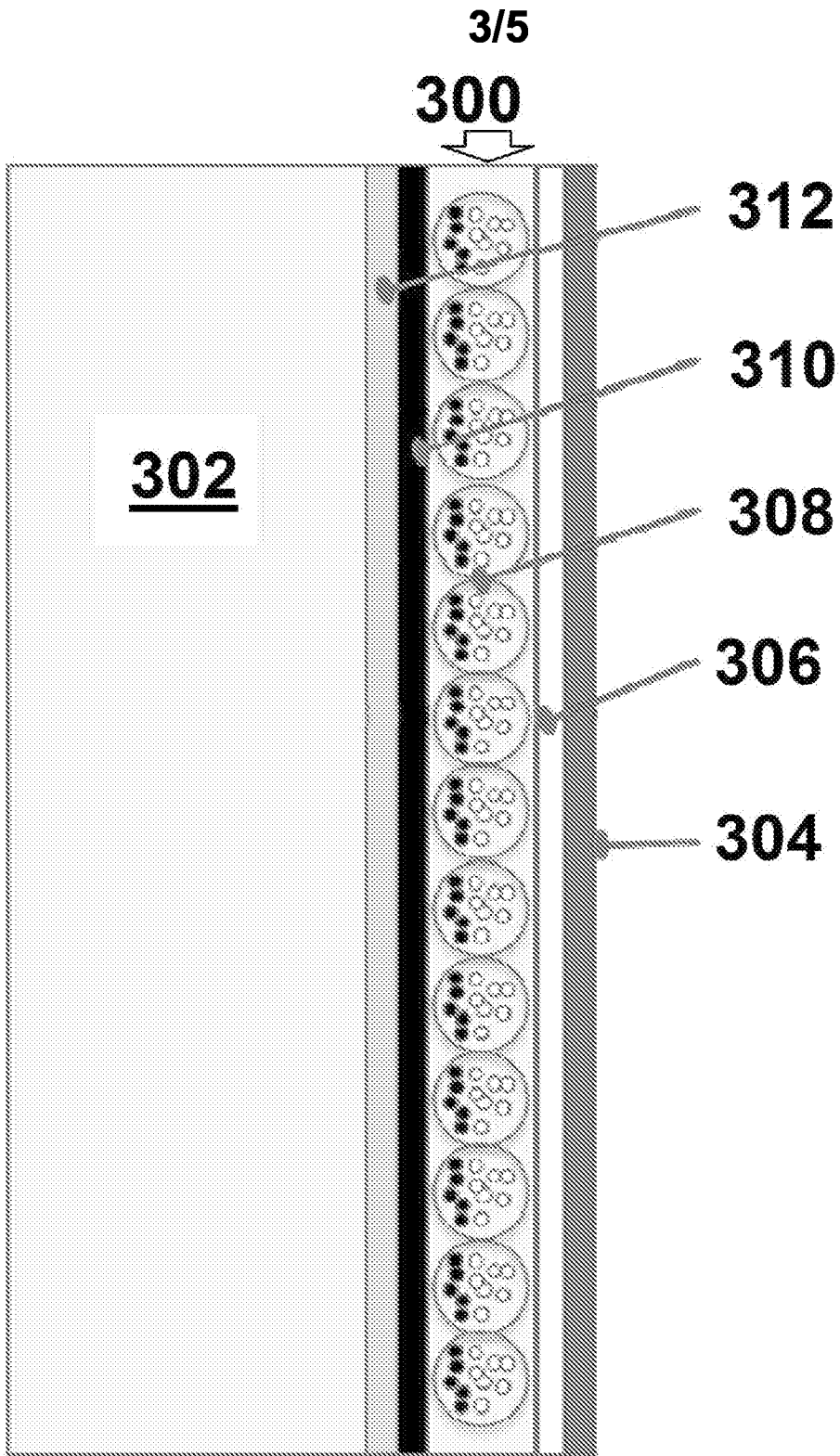

Fig. 2



**Fig. 3**

4/5

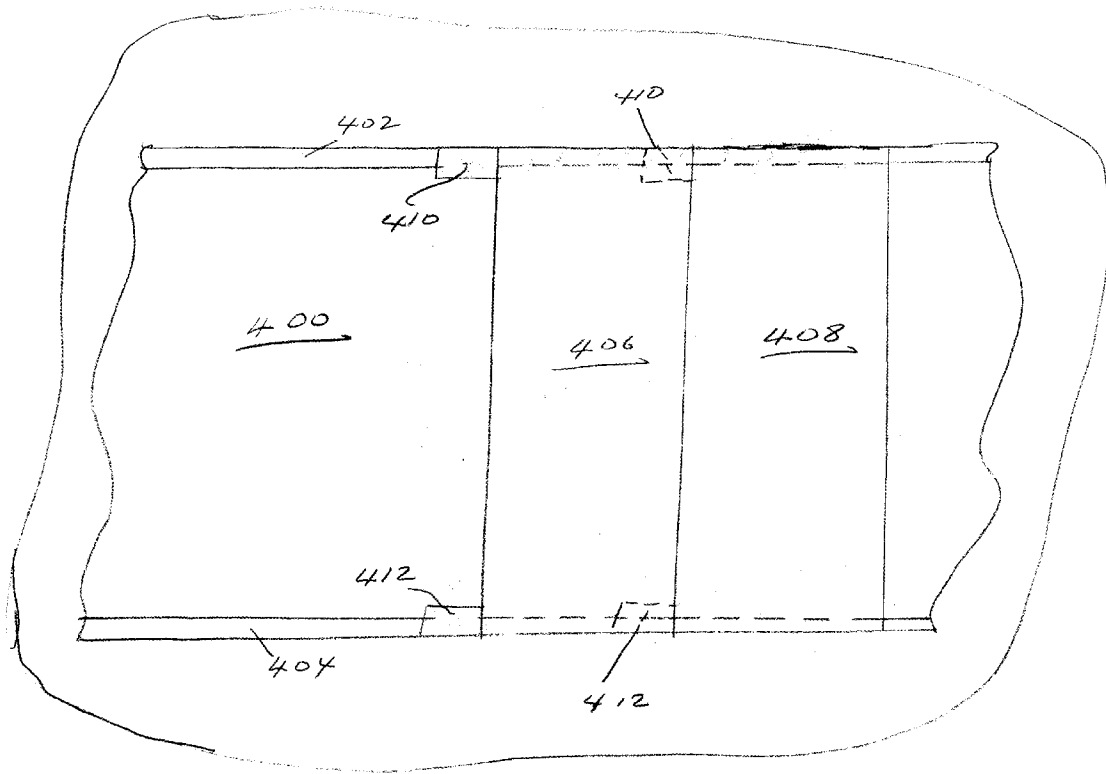

Fig.4



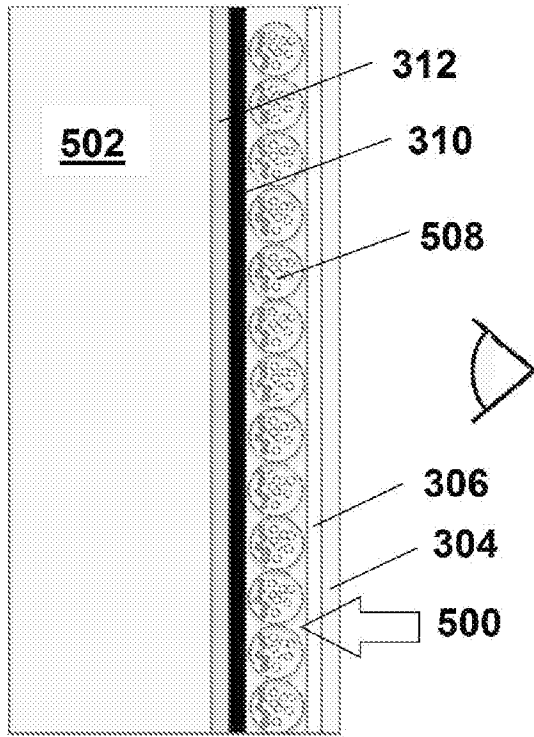

Fig. 5A

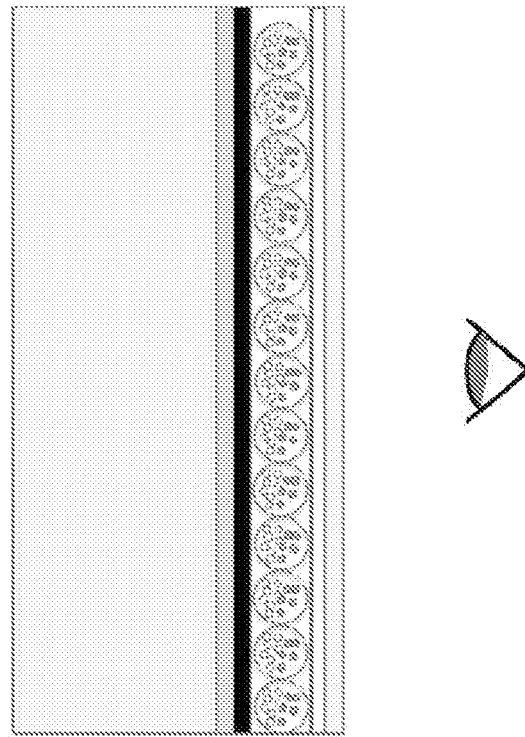

Fig. 5B

**A. CLASSIFICATION OF SUBJECT MATTER****G02B 27/22(2006.01)i**

According to International Patent Classification (IPC) or to both national classification and IPC

**B. FIELDS SEARCHED**Minimum documentation searched (classification system followed by classification symbols)  
G02B 27/22; G02B 26/00; G02B 5/23; G02F 1/03; G02F 1/29; G09G 3/20Documentation searched other than minimum documentation to the extent that such documents are included in the fields searched  
Korean utility models and applications for utility models  
Japanese utility models and applications for utility modelsElectronic data base consulted during the international search (name of data base and, where practicable, search terms used)  
eKOMPASS(KIPO internal) & Keywords: electro-optic, projector, screen, display, electrode**C. DOCUMENTS CONSIDERED TO BE RELEVANT**

Category*	Citation of document, with indication, where appropriate, of the relevant passages	Relevant to claim No.
Y	US 2003-0076573 A1 (HOLLY G. GATES et al.) 24 April 2003 See paragraphs [0009],[0028],[0104],[0126], claims 1,29,36 and figure 13.	1-18
Y	US 2016-0232835 A1 (E INK CORPORATION) 11 August 2016 See paragraphs [0032],[0057],[0060],[0066], claim 12 and figure 2.	1-18
A	US 2005-0152022 A1 (CHARLES HOWIE HONEYMAN et al.) 14 July 2005 See paragraphs [0048]-[0050] and figures 2-3.	1-18
A	US 2008-0239458 A1 (JONATHAN A. SACHS et al.) 02 October 2008 See paragraph [0058], claims 1-4 and figure 10.	1-18
A	US 3932025 A (ANDRAS I. LAKATOS et al.) 13 January 1976 See claims 1-5.	1-18

 Further documents are listed in the continuation of Box C. See patent family annex.

\* Special categories of cited documents:

"A" document defining the general state of the art which is not considered to be of particular relevance

"E" earlier application or patent but published on or after the international filing date

"L" document which may throw doubts on priority claim(s) or which is cited to establish the publication date of another citation or other special reason (as specified)

"O" document referring to an oral disclosure, use, exhibition or other means

"P" document published prior to the international filing date but later than the priority date claimed

"T" later document published after the international filing date or priority date and not in conflict with the application but cited to understand the principle or theory underlying the invention

"X" document of particular relevance; the claimed invention cannot be considered novel or cannot be considered to involve an inventive step when the document is taken alone

"Y" document of particular relevance; the claimed invention cannot be considered to involve an inventive step when the document is combined with one or more other such documents, such combination being obvious to a person skilled in the art

"&amp;" document member of the same patent family

Date of the actual completion of the international search

12 April 2019 (12.04.2019)

Date of mailing of the international search report

**12 April 2019 (12.04.2019)**

Name and mailing address of the ISA/KR

International Application Division  
Korean Intellectual Property Office  
189 Cheongsa-ro, Seo-gu, Daejeon, 35208, Republic of Korea

Facsimile No. +82-42-481-8578

Authorized officer

KANG, Sung Chul

Telephone No. +82-42-481-8405



**INTERNATIONAL SEARCH REPORT**

Information on patent family members

International application No.

**PCT/US2018/066419**

Patent document cited in search report	Publication date	Patent family member(s)	Publication date
US 2003-0076573 A1	24/04/2003	AT 215255 T	15/04/2002
		AT 228681 T	15/12/2002
		AT 232308 T	15/02/2003
		AT 276536 T	15/10/2004
		AT 280963 T	15/11/2004
		AT 324615 T	15/05/2006
		AT 349722 T	15/01/2007
		AT 350770 T	15/01/2007
		AT 356369 T	15/03/2007
		AT 494572 T	15/01/2011
		AT 495553 T	15/01/2011
		AT 549753 T	15/03/2012
		AT 552530 T	15/04/2012
		AU 1412799 A	07/06/1999
		AU 1940000 A	03/07/2000
		AU 2002-366174 A1	10/06/2003
		AU 2002-366174 A8	10/06/2003
		AU 2003-239619 A1	31/12/2003
		AU 2003-239619 A8	31/12/2003
		AU 2186000 A	03/07/2000
		AU 2195900 A	03/07/2000
		AU 2487899 A	16/08/1999
		AU 2989599 A	20/09/1999
		AU 3052002 A	11/06/2002
		AU 3190499 A	11/10/1999
		AU 3487599 A	01/11/1999
		AU 3552699 A	01/11/1999
		AU 3767899 A	16/11/1999
		AU 3987299 A	29/11/1999
		AU 4703999 A	10/01/2000
		AU 5094699 A	01/02/2000
		AU 5094899 A	01/02/2000
		AU 5224399 A	14/02/2000
		AU 6293699 A	26/04/2000
		AU 6358000 A	13/02/2001
		AU 6504296 A	18/02/1997
AU 6955096 A	10/02/1998		
AU 7103300 A	26/03/2001		
AU 7202400 A	28/06/2001		
AU 726057 B2	26/10/2000		
AU 760703 B2	22/05/2003		
AU 761075 B2	29/05/2003		
AU 9122598 A	16/03/1999		
AU 9206398 A	16/03/1999		
AU 9207898 A	16/03/1999		
BR 9814454 A	03/10/2000		
BR 9814455 A	03/10/2000		
BR 9814456 A	03/10/2000		
CA 2260947 A1	29/01/1998		

**INTERNATIONAL SEARCH REPORT**

Information on patent family members

International application No.

**PCT/US2018/066419**

Patent document cited in search report	Publication date	Patent family member(s)	Publication date
		CA 2300827 A1	04/03/1999
		CA 2300830 A1	04/03/1999
		CA 2300830 C	10/04/2007
		CA 2300849 A1	04/03/1999
		CA 2317459 A1	05/08/1999
		CA 2320788 A1	23/09/1999
		CA 2321131 A1	21/10/1999
		CA 2321131 C	08/04/2008
		CA 2323879 A1	21/10/1999
		CA 2323879 C	16/01/2007
		CA 2329173 A1	04/11/1999
		CA 2330950 A1	18/11/1999
		CA 2333358 A1	29/12/1999
		CA 2336101 A1	20/01/2000
		CA 2336596 A1	20/01/2000
		CA 2336744 A1	03/02/2000
		CA 2345619 A1	13/04/2000
		CA 2345619 C	08/04/2008
		CA 2352062 A1	22/06/2000
		CA 2352063 A1	22/06/2000
		CA 2353608 A1	22/06/2000
		CA 2497391 A1	17/08/2006
		CA 2553137 A1	29/01/1998
		CA 2612822 A1	12/01/2006
		CN 101002129 A	18/07/2007
		CN 101027711 A	29/08/2007
		CN 101029986 A	05/09/2007
		CN 101029986 B	16/06/2010
		CN 101233557 A	30/07/2008
		CN 101233557 B	14/04/2010
		CN 101261812 A	10/09/2008
		CN 101261812 B	08/12/2010
		CN 101373581 A	25/02/2009
		CN 101373581 B	16/07/2014
		CN 101387809 A	18/03/2009
		CN 101390148 A	18/03/2009
		CN 101390148 B	06/07/2011
		CN 101393369 A	25/03/2009
		CN 101393369 B	27/03/2013
		CN 101430864 A	13/05/2009
		CN 101430864 B	07/03/2012
		CN 101601080 A	09/12/2009
		CN 101601080 B	23/10/2013
		CN 101676980 A	24/03/2010
		CN 101676980 B	04/06/2014
		CN 101800033 A	11/08/2010
		CN 101800033 B	29/05/2013
		CN 101800034 A	11/08/2010
		CN 101800034 B	06/03/2013
		CN 101826304 A	08/09/2010

**INTERNATIONAL SEARCH REPORT**

Information on patent family members

International application No.

**PCT/US2018/066419**

Patent document cited in search report	Publication date	Patent family member(s)	Publication date
		CN 101826304 B	14/03/2012
		CN 101859544 A	13/10/2010
		CN 101859544 B	04/07/2012
		CN 101882423 A	10/11/2010
		CN 101882423 B	12/02/2014
		CN 102027528 A	20/04/2011
		CN 102027528 B	27/08/2014
		CN 102074200 A	25/05/2011
		CN 102074200 B	28/11/2012
		CN 102106025 A	22/06/2011
		CN 102640043 A	15/08/2012
		CN 102640043 B	01/10/2014
		CN 102768822 A	07/11/2012
		CN 102768822 B	02/12/2015
		CN 102789758 A	21/11/2012
		CN 102789758 B	18/05/2016
		CN 102789764 A	21/11/2012
		CN 102789764 B	27/05/2015
		CN 102834857 A	19/12/2012
		CN 102834857 B	02/03/2016
		CN 102939561 A	20/02/2013
		CN 103474034 A	25/12/2013
		CN 103711831 A	09/04/2014
		CN 103711831 B	04/08/2017
		CN 104238227 A	24/12/2014
		CN 105654889 A	08/06/2016
		CN 1500229 A	26/05/2004
		CN 1589462 A	02/03/2005
		CN 1589462 B	27/03/2013
		CN 1659618 A	24/08/2005
		CN 1768366 A	03/05/2006
		CN 1813279 A	02/08/2006
		CN 1813281 A	02/08/2006
		CN 1890594 A	03/01/2007
		CN 1938746 A	28/03/2007
		DE 102013218582 A1	03/04/2014
		EP 0839356 A2	06/05/1998
		EP 0912913 A1	06/05/1999
		EP 1010035 A1	21/06/2000
		EP 1010035 B1	27/10/2004
		EP 1010036 A1	21/06/2000
		EP 1010036 B1	23/06/2004
		EP 1010037 A1	21/06/2000
		EP 1010037 B1	07/05/2003
		EP 1016942 A2	05/07/2000
		EP 1016942 A3	21/11/2001
		EP 1016942 B1	25/05/2005
		EP 1051511 A1	15/11/2000
		EP 1064584 A1	03/01/2001
		EP 1064584 B1	19/05/2004

**INTERNATIONAL SEARCH REPORT**

Information on patent family members

International application No.

**PCT/US2018/066419**

Patent document cited in search report	Publication date	Patent family member(s)	Publication date
		EP 1070276 A1	24/01/2001
		EP 1070276 B1	01/06/2005
		EP 1075670 A1	14/02/2001
		EP 1075670 B1	17/12/2008
		EP 1078331 A2	28/02/2001
		EP 1093600 A1	25/04/2001
		EP 1093600 B1	15/09/2004
		EP 1095354 A1	02/05/2001
		EP 1095354 B1	27/11/2002
		EP 1099207 A1	16/05/2001
		EP 1099207 B1	27/03/2002
		EP 1105772 A1	13/06/2001
		EP 1105772 B1	23/06/2004
		EP 1118038 A1	25/07/2001
		EP 1141889 A1	10/10/2001
		EP 1145072 A2	17/10/2001
		EP 1145072 A3	02/05/2002
		EP 1145072 B1	07/05/2003
		EP 1149325 A1	31/10/2001
		EP 1149325 B1	05/02/2003
		EP 1149423 A1	31/10/2001
		EP 1149423 B1	03/01/2007
		EP 1198851 A1	24/04/2002
		EP 1198851 B1	14/03/2012
		EP 1208612 A1	29/05/2002
		EP 1208612 B1	12/01/2011
		EP 1231500 A2	14/08/2002
		EP 1231500 A3	09/07/2003
		EP 1231500 B1	07/03/2007
		EP 1335211 A2	13/08/2003
		EP 1335211 A3	26/11/2003
		EP 1335211 B1	03/06/2015
		EP 1340216 A2	03/09/2003
		EP 1342126 A2	10/09/2003
		EP 1370905 A1	17/12/2003
		EP 1370905 B1	05/01/2011
		EP 1390810 A1	25/02/2004
		EP 1390810 B1	26/04/2006
		EP 1393122 A1	03/03/2004
		EP 1393122 B1	28/03/2018
		EP 1446791 A2	18/08/2004
		EP 1446791 B1	09/09/2015
		EP 1482355 A2	01/12/2004
		EP 1482355 A3	20/04/2005
		EP 1482355 B1	27/12/2006
		EP 1507165 A1	16/02/2005
		EP 1512137 A2	09/03/2005
		EP 1557714 A2	27/07/2005
		EP 1557714 A3	28/09/2005
		EP 1557714 B1	06/11/2013

**INTERNATIONAL SEARCH REPORT**

Information on patent family members

International application No.

**PCT/US2018/066419**

Patent document cited in search report	Publication date	Patent family member(s)	Publication date
		EP 1614097 A1	11/01/2006
		EP 1614097 A4	12/08/2009
		EP 1623405 A2	08/02/2006
		EP 1623405 A4	05/09/2007
		EP 1623405 B1	29/07/2015
		EP 1639574 A1	29/03/2006
		EP 1639574 A4	21/01/2009
		EP 1639574 B1	22/04/2015
		EP 1666964 A2	07/06/2006
		EP 1666964 A3	14/03/2007
		EP 1671172 A2	21/06/2006
		EP 1671172 A4	22/08/2007
		EP 1697786 A2	06/09/2006
		EP 1697786 A4	24/09/2008
		EP 1735652 A2	27/12/2006
		EP 1735652 A4	16/06/2010
		EP 1735652 B1	11/05/2016
		EP 1743316 A2	17/01/2007
		EP 1743316 A4	26/08/2009
		EP 1754995 A2	21/02/2007
		EP 1754995 A3	23/05/2007
		EP 1754995 B1	04/04/2012
		EP 1772768 A2	11/04/2007
		EP 1772768 A3	16/07/2008
		EP 1779174 A1	02/05/2007
		EP 1779174 A4	05/05/2010
		EP 1784813 A2	16/05/2007
		EP 1784813 A4	21/09/2011
		EP 1784813 B1	14/12/2016
		EP 1911016 A2	16/04/2008
		EP 1911016 A4	27/01/2010
		EP 1911016 B1	02/03/2016
		EP 2024955 A2	18/02/2009
		EP 2024955 A4	15/09/2010
		EP 2122405 A2	25/11/2009
		EP 2122405 A4	24/02/2010
		EP 2122405 B1	16/11/2016
		EP 2122405 B8	21/12/2016
		EP 2126885 A1	02/12/2009
		EP 2126885 A4	13/04/2011
		EP 2126885 B1	02/01/2013
		EP 2548077 A2	23/01/2013
		EP 2548077 A4	22/01/2014
		EP 2548077 B1	21/02/2018
		EP 2555182 A1	06/02/2013
		EP 2556499 A2	13/02/2013
		EP 2556499 A4	04/09/2013
		EP 2916312 A1	09/09/2015
		EP 2916312 A8	28/10/2015
		EP 2916312 B1	28/06/2017

**INTERNATIONAL SEARCH REPORT**

Information on patent family members

International application No.

**PCT/US2018/066419**

Patent document cited in search report	Publication date	Patent family member(s)	Publication date
		EP 2947647 A2	25/11/2015
		EP 2947647 A3	16/12/2015
		EP 3067744 A2	14/09/2016
		EP 3067744 A3	04/01/2017
		EP 3067744 B1	20/12/2017
		HK 1064746 A1	20/04/2007
		HK 1073380 A1	09/08/2013
		HK 1079325 A1	22/05/2009
		HK 1088107 A1	29/05/2009
		HK 1092923 A1	22/05/2009
		HK 1093254 A1	12/02/2010
		HK 1097602 A1	15/05/2009
		HK 1103840 A1	24/12/2009
		HK 1107154 A1	20/08/2010
		HK 1108963 A1	31/07/2009
		HK 1118371 A1	16/12/2011
		HK 1118936 A1	02/09/2011
		HK 1128809 A1	14/09/2012
		HK 1129484 A1	27/02/2015
		HK 1130357 A1	11/05/2012
		HK 1132334 A1	11/10/2013
		HK 1136901 A1	17/04/2014
		HK 1142162 A1	30/01/2015
		HK 1147339 A1	29/11/2013
		HK 1147340 A1	02/08/2013
		HK 1148102 A1	21/12/2012
		HK 1149363 A1	12/04/2013
		HK 1150466 A1	18/07/2014
		HK 1152582 A1	30/01/2015
		HK 1157925 A1	03/05/2013
		HK 1171266 A1	12/06/2015
		HK 1175287 A1	13/11/2015
		HK 1175579 A1	26/08/2016
		HK 1176454 A1	24/02/2017
		HK 1179741 A1	05/05/2017
		HK 1205275 A1	11/12/2015
		JP 2000-194220 A	14/07/2000
		JP 2001-500172 A	09/01/2001
		JP 2002-221918 A	09/08/2002
		JP 2002-501757 A	22/01/2002
		JP 2002-504696 A	12/02/2002
		JP 2002-507765 A	12/03/2002
		JP 2002-511606 A	16/04/2002
		JP 2002-511607 A	16/04/2002
		JP 2002-513169 A	08/05/2002
		JP 2002-514793 A	21/05/2002
		JP 2002-520655 A	09/07/2002
		JP 2002-526812 A	20/08/2002
		JP 2002-532756 A	02/10/2002
		JP 3833266 B2	11/10/2006



**INTERNATIONAL SEARCH REPORT**

Information on patent family members

International application No.

**PCT/US2018/066419**

Patent document cited in search report	Publication date	Patent family member(s)	Publication date
		JP 3901197 B2	04/04/2007
		JP 4105107 B2	25/06/2008
		JP 4188091 B2	26/11/2008
		JP 4209436 B2	14/01/2009
		JP 4410135 B2	03/02/2010
		JP 4460149 B2	12/05/2010
		JP 4460150 B2	12/05/2010
		JP 4460151 B2	12/05/2010
		JP 4460507 B2	12/05/2010
		JP 4460508 B2	12/05/2010
		JP 4511048 B2	28/07/2010
		JP 4568429 B2	27/10/2010
		JP 4568477 B2	27/10/2010
		JP 4599349 B2	15/12/2010
		JP 4615860 B2	19/01/2011
		JP 4633793 B2	23/02/2011
		JP 4651193 B2	16/03/2011
		JP 4651383 B2	16/03/2011
		JP 4664501 B2	06/04/2011
		JP 4672727 B2	20/04/2011
		JP 4740943 B2	03/08/2011
		JP 4776532 B2	21/09/2011
		JP 4790622 B2	12/10/2011
		JP 4848280 B2	28/12/2011
		JP 4852478 B2	11/01/2012
		JP 4852572 B2	11/01/2012
		JP 4889129 B2	07/03/2012
		JP 4938266 B2	23/05/2012
		JP 4940227 B2	30/05/2012
		JP 4972260 B2	11/07/2012
		JP 4997623 B2	08/08/2012
		JP 5005800 B2	22/08/2012
		JP 5008791 B2	22/08/2012
		JP 5047331 B2	10/10/2012
		JP 5097316 B2	12/12/2012
		JP 5117470 B2	16/01/2013
		JP 5186492 B2	17/04/2013
		JP 5208341 B2	12/06/2013
		JP 5250580 B2	31/07/2013
		JP 5409845 B2	05/02/2014
		JP 5421965 B2	19/02/2014
		JP 5421966 B2	19/02/2014
		JP 5542283 B2	09/07/2014
		JP 5560294 B2	23/07/2014
		JP 5580891 B2	27/08/2014
		JP 5615851 B2	29/10/2014
		JP 5616207 B2	29/10/2014
		JP 5618811 B2	05/11/2014
		JP 5632164 B2	26/11/2014
		JP 5632861 B2	26/11/2014

## INTERNATIONAL SEARCH REPORT

Information on patent family members

International application No.

**PCT/US2018/066419**

Patent document cited in search report	Publication date	Patent family member(s)	Publication date
		JP 5641721 B2	17/12/2014
		JP 5677257 B2	25/02/2015
		JP 5677266 B2	25/02/2015
		JP 5706606 B2	22/04/2015
		JP 5718651 B2	13/05/2015
		JP 5734395 B2	17/06/2015
		JP 5739319 B2	24/06/2015
		JP 5758440 B2	05/08/2015
		JP 5765875 B2	19/08/2015
		JP 5785584 B2	30/09/2015
		JP 5805167 B2	04/11/2015
		JP 5869776 B2	24/02/2016
		JP 5873241 B2	01/03/2016
		JP 5904690 B2	20/04/2016
		JP 5904931 B2	20/04/2016
		JP 5904990 B2	20/04/2016
		JP 5905061 B2	20/04/2016
		JP 5908048 B2	26/04/2016
		JP 5928840 B2	01/06/2016
		JP 5931038 B2	08/06/2016
		JP 6014444 B2	25/10/2016
		JP 6075934 B2	08/02/2017
		JP 6076942 B2	08/02/2017
		JP 6284564 B2	28/02/2018
US 2016-0232835 A1	11/08/2016	CA 2969474 A1	14/07/2016
		CN 107111201 A	29/08/2017
		EP 3243105 A1	15/11/2017
		JP 2018-503873 A	08/02/2018
		JP 6430021 B2	28/11/2018
		KR 10-2017-0089925 A	04/08/2017
		TW 201629608 A	16/08/2016
		TW 201721265 A	16/06/2017
		TW 201831975 A	01/09/2018
		TW I579628 B	21/04/2017
		TW I631406 B	01/08/2018
		WO 2016-111995 A1	14/07/2016
US 2005-0152022 A1	14/07/2005	US 7206119 B2	17/04/2007
		WO 2005-065340 A2	21/07/2005
		WO 2005-065340 A3	29/12/2005
US 2008-0239458 A1	02/10/2008	US 7990600 B2	02/08/2011
		WO 2005-116719 A2	08/12/2005
		WO 2005-116719 A3	28/09/2006
US 3932025 A	13/01/1976	None	