



(19) **United States**  
(12) **Patent Application Publication**  
**Vo et al.**

(10) **Pub. No.: US 2010/0004518 A1**  
(43) **Pub. Date: Jan. 7, 2010**

(54) **HEAT SINK FOR NONINVASIVE MEDICAL SENSOR**

(75) Inventors: **Hung Vo**, Garden Grove, CA (US); **Marcelo Lamego**, Coto De Caza, CA (US); **Sean Merritt**, Lake Forest, CA (US); **Cristiano Dalvi**, Mission Viejo, CA (US); **Johannes Bruinsma**, Mission Viejo, CA (US); **Jeroen Poeze**, Mission Viejo, CA (US); **Ferdyan Lesmana**, Irvine, CA (US); **Greg Olsen**, Trabuco Canyon, CA (US); **Massi Joe E. Kiani**, Languna Niguel, CA (US)

(60) Provisional application No. 61/086,060, filed on Aug. 4, 2008, provisional application No. 61/086,108, filed on Aug. 4, 2008, provisional application No. 61/086,063, filed on Aug. 4, 2008, provisional application No. 61/086,057, filed on Aug. 4, 2008, provisional application No. 61/078,228, filed on Jul. 3, 2008, provisional application No. 61/078,207, filed on Jul. 3, 2008, provisional application No. 61/091,732, filed on Aug. 25, 2008.

**Publication Classification**

(51) **Int. Cl.**  
*A61B 5/1468* (2006.01)  
*F28F 7/00* (2006.01)  
(52) **U.S. Cl.** ..... **600/310**; 165/185

Correspondence Address:  
**KNOBBE MARTENS OLSON & BEAR LLP**  
**2040 MAIN STREET, FOURTEENTH FLOOR**  
**IRVINE, CA 92614 (US)**

(73) Assignee: **MASIMO LABORATORIES, INC.**, Irvine, CA (US)

(21) Appl. No.: **12/497,506**

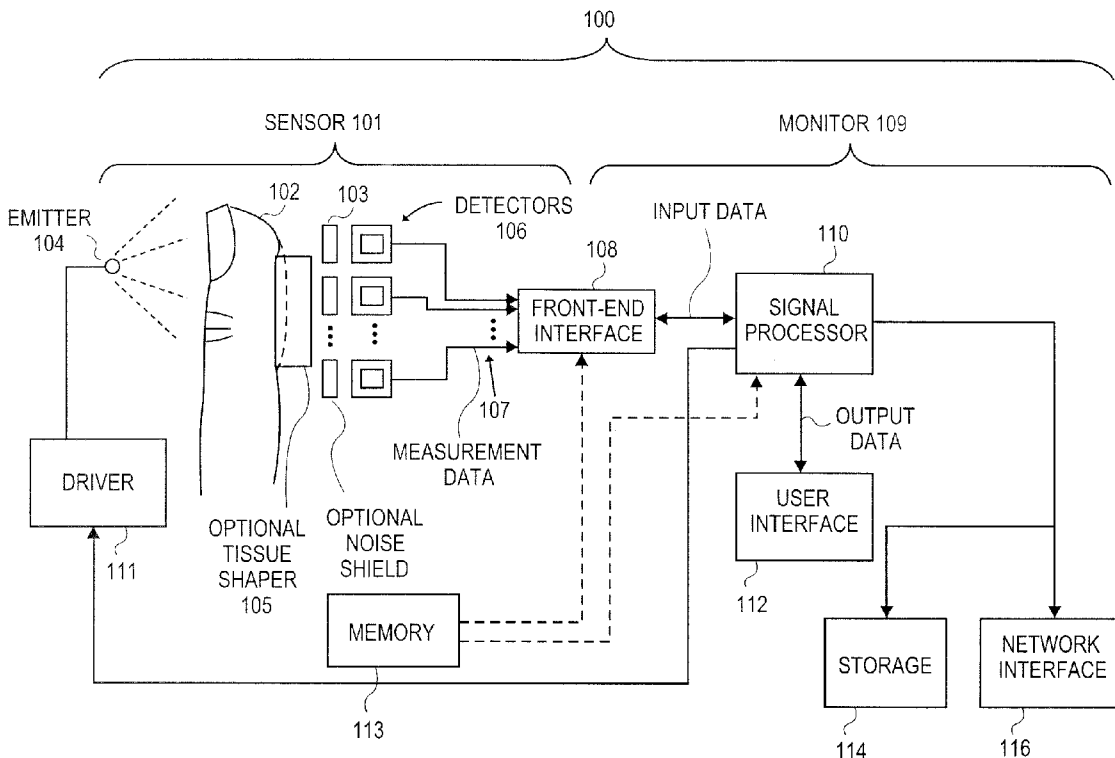
(22) Filed: **Jul. 2, 2009**

**Related U.S. Application Data**

(63) Continuation-in-part of application No. 29/323,409, filed on Aug. 25, 2008, Continuation-in-part of application No. 29/323,408, filed on Aug. 25, 2008.

**ABSTRACT**

A noninvasive physiological sensor for measuring one or more physiological parameters of a medical patient can include a bump interposed between a light source and a photodetector. The bump can be placed in contact with body tissue of a patient and thereby reduce a thickness of the body tissue. As a result, an optical pathlength between the light source and the photodetector can be reduced. In addition, the sensor can include a heat sink that can direct heat away from the light source. Moreover, the sensor can include shielding in the optical path between the light source and the photodetector. The shielding can reduce noise received by the photodetector.



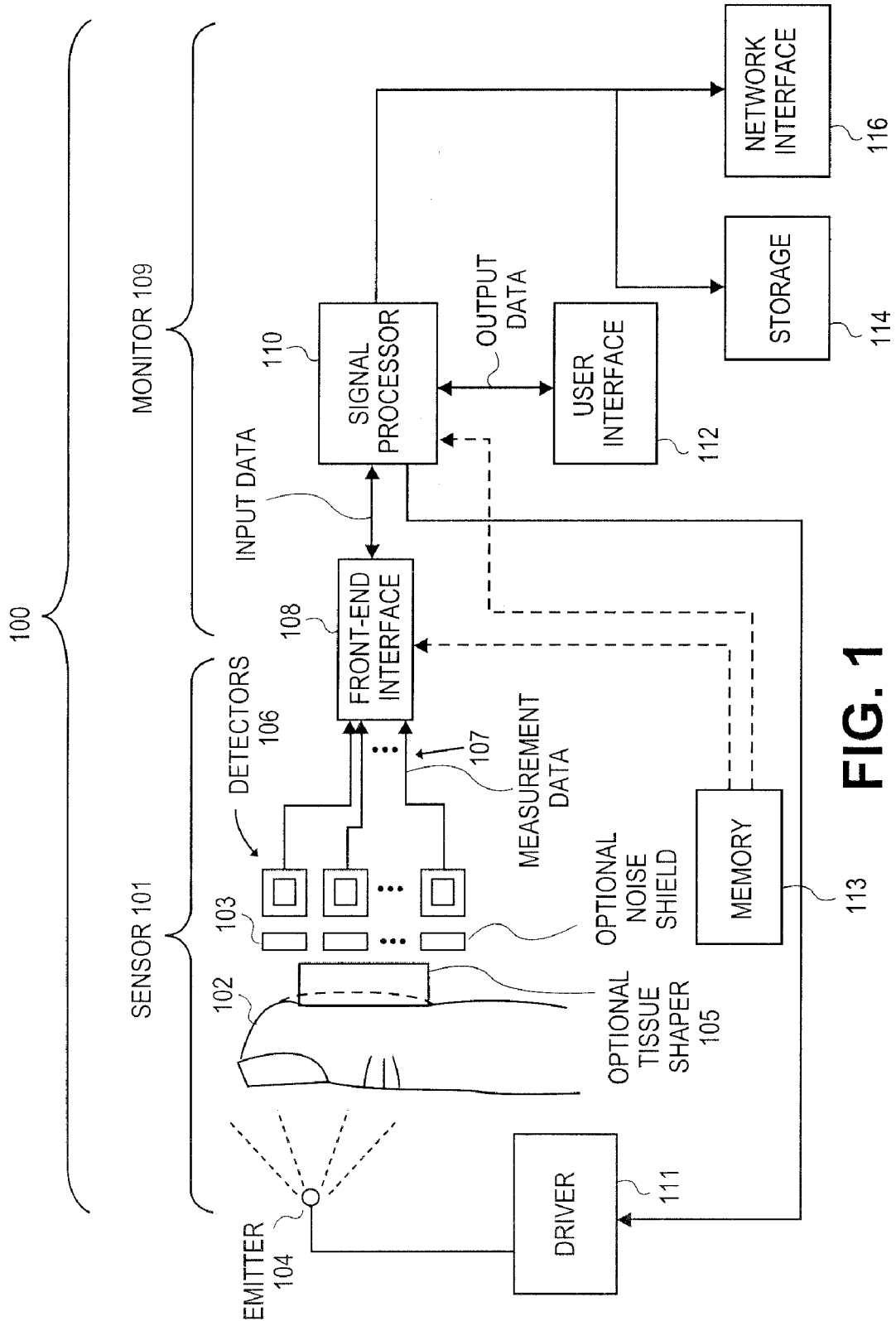
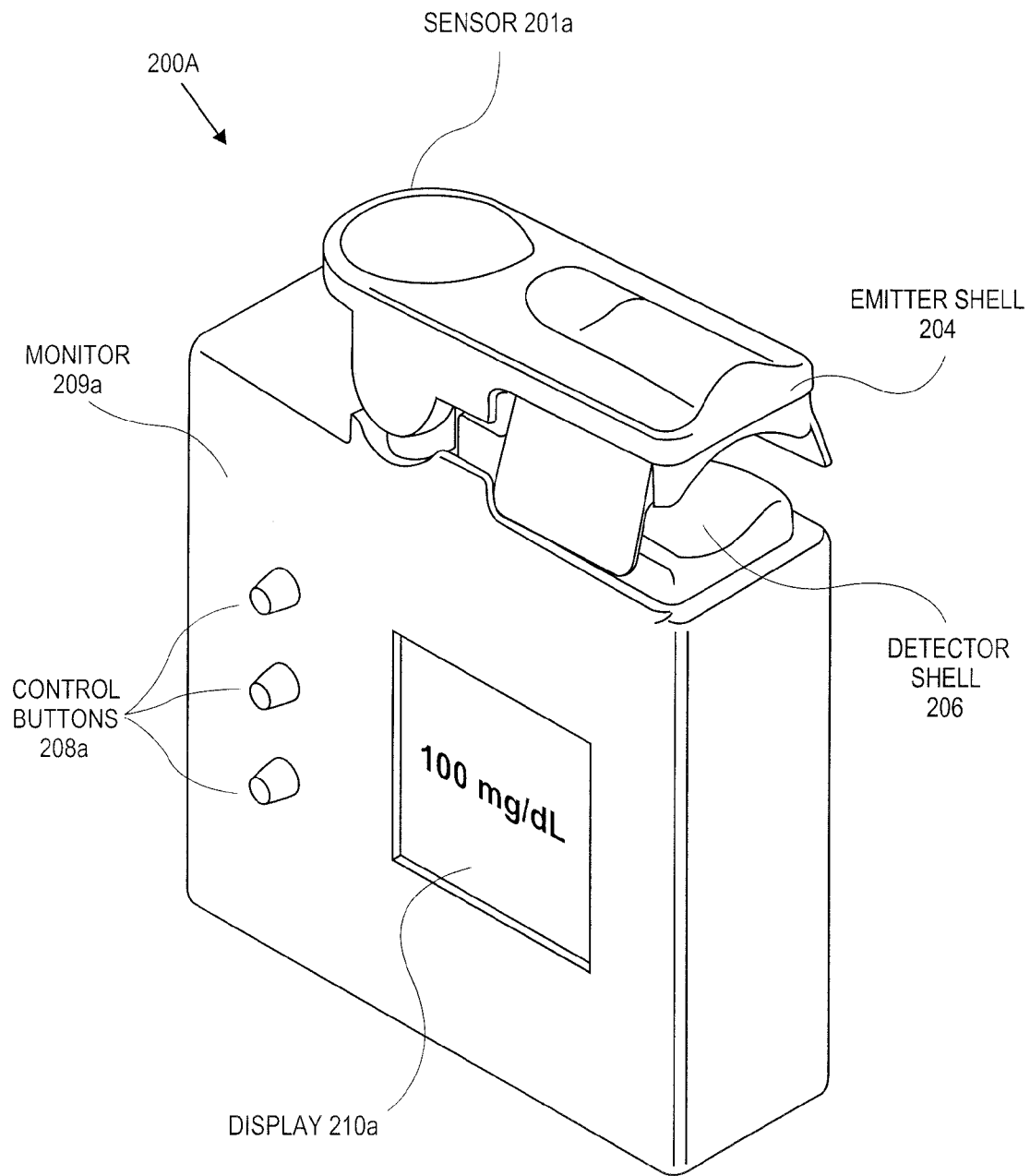


FIG. 1



**FIG. 2A**

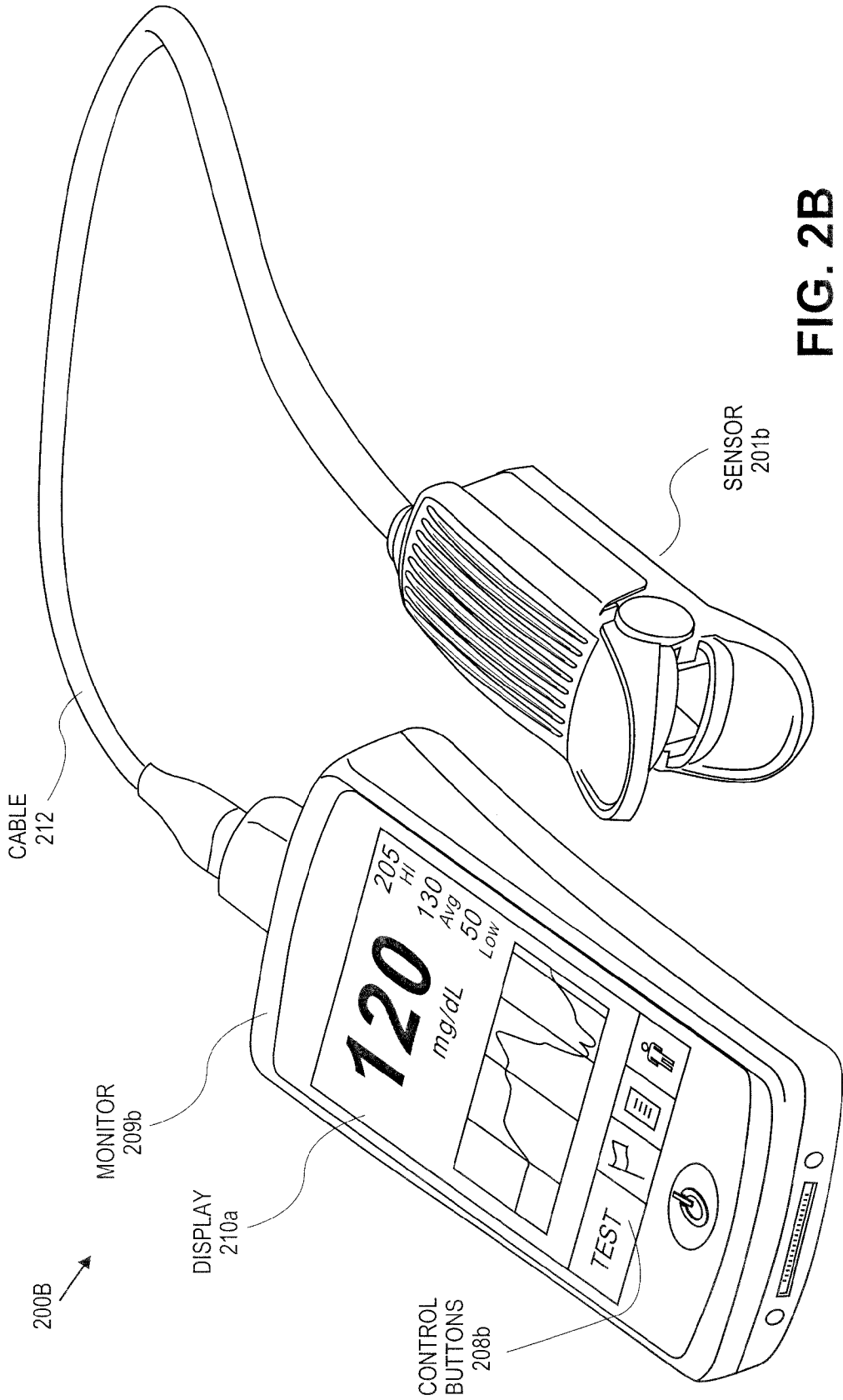
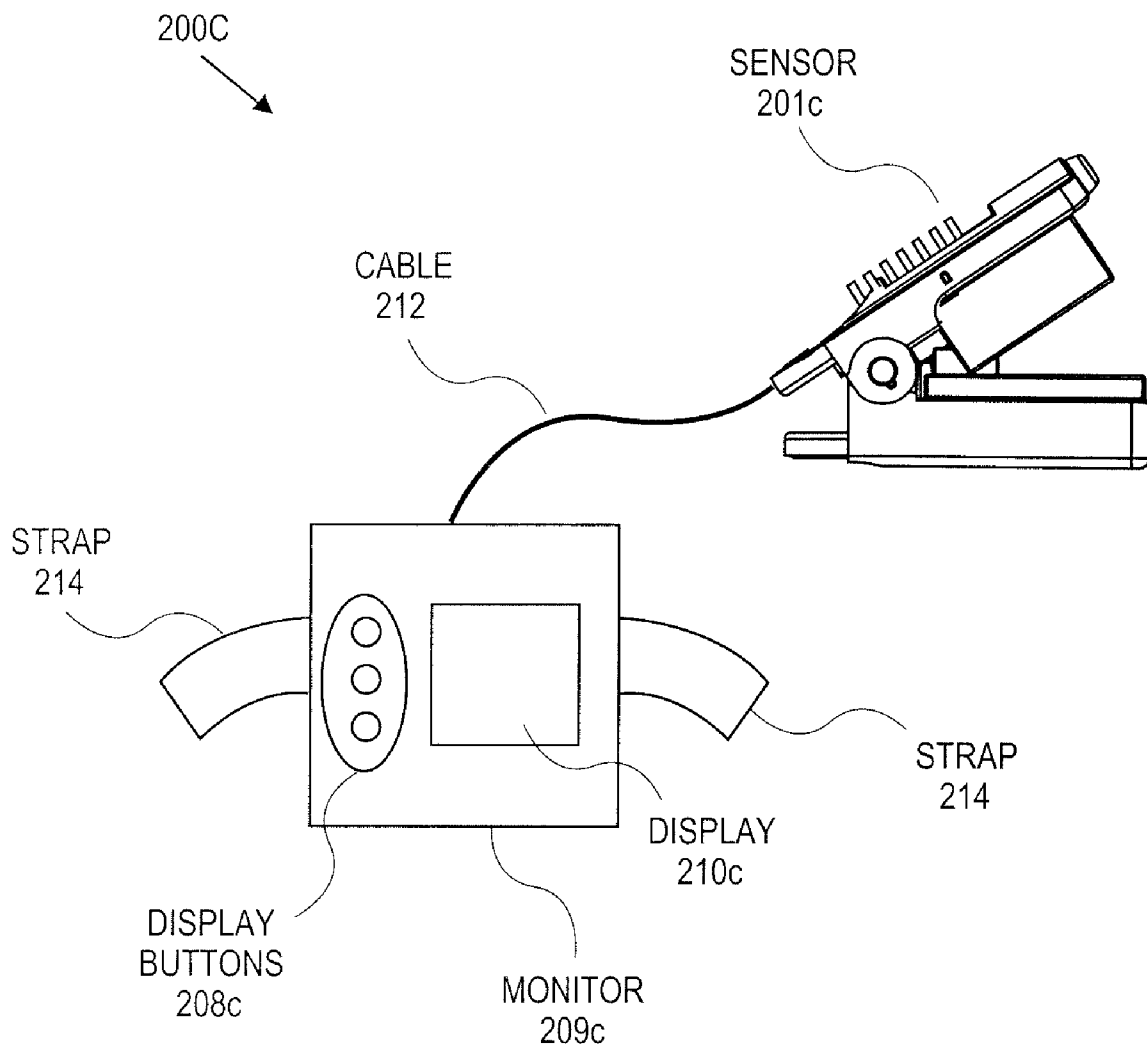


FIG. 2B



**FIG. 2C**

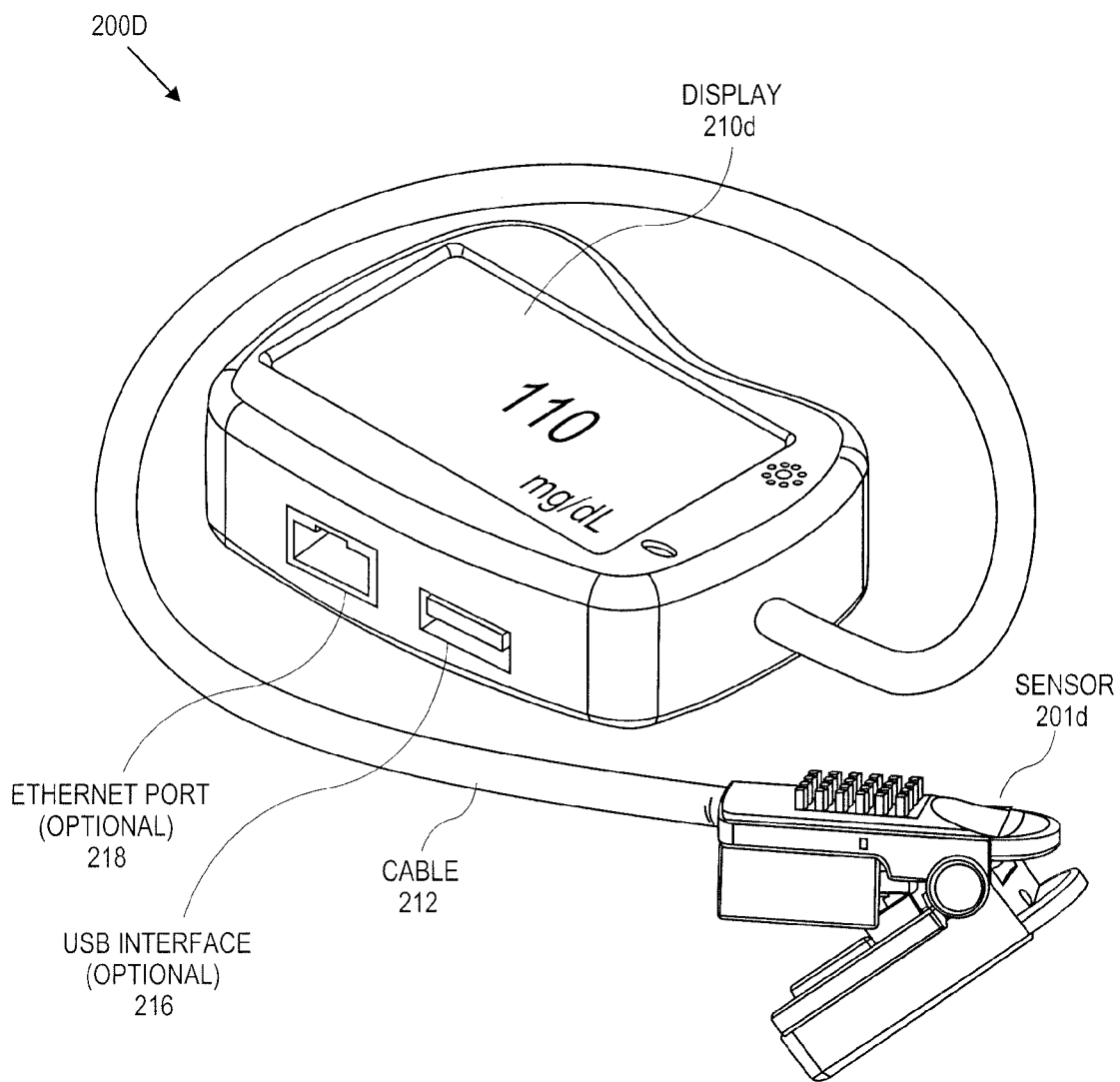


FIG. 2D

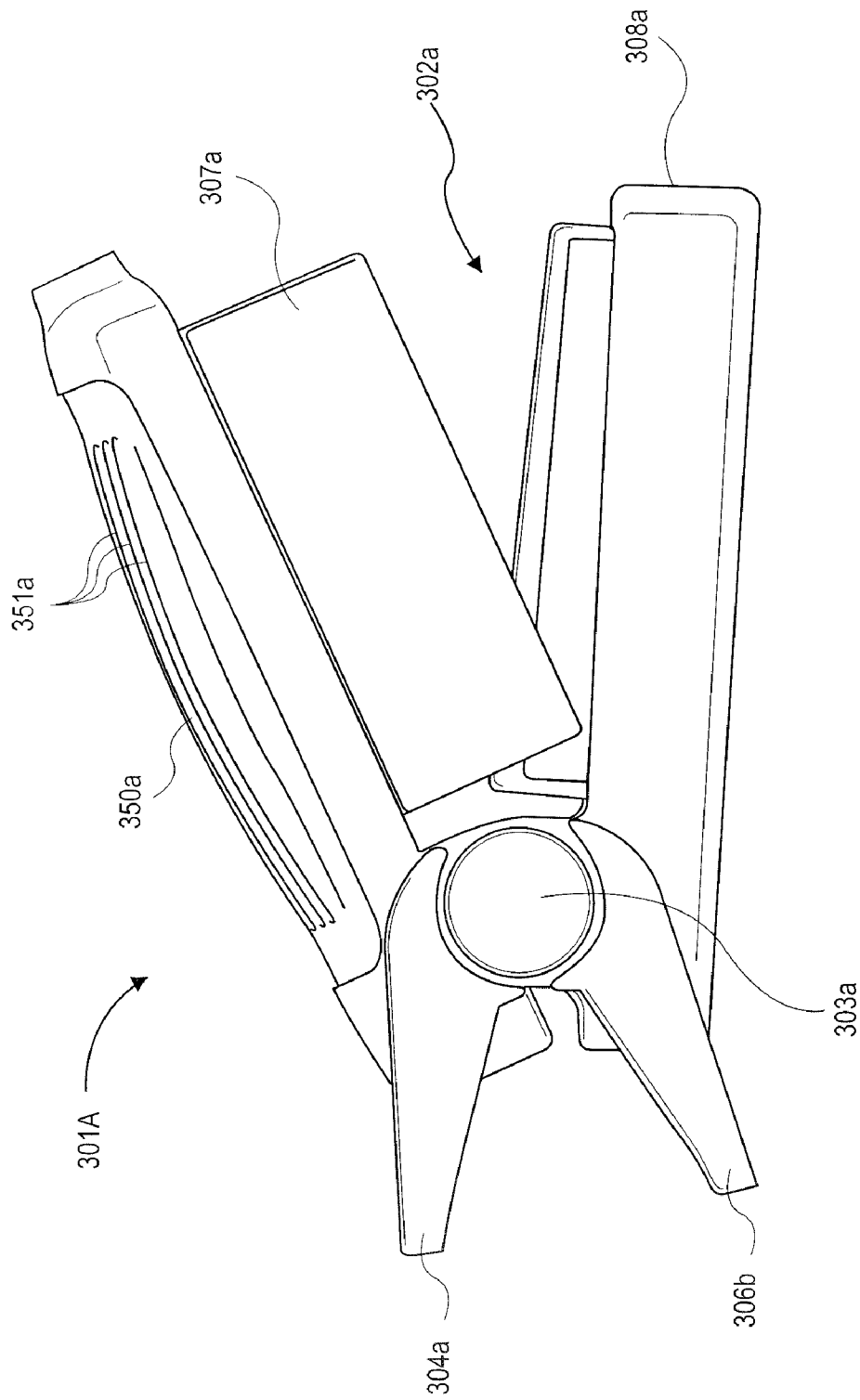
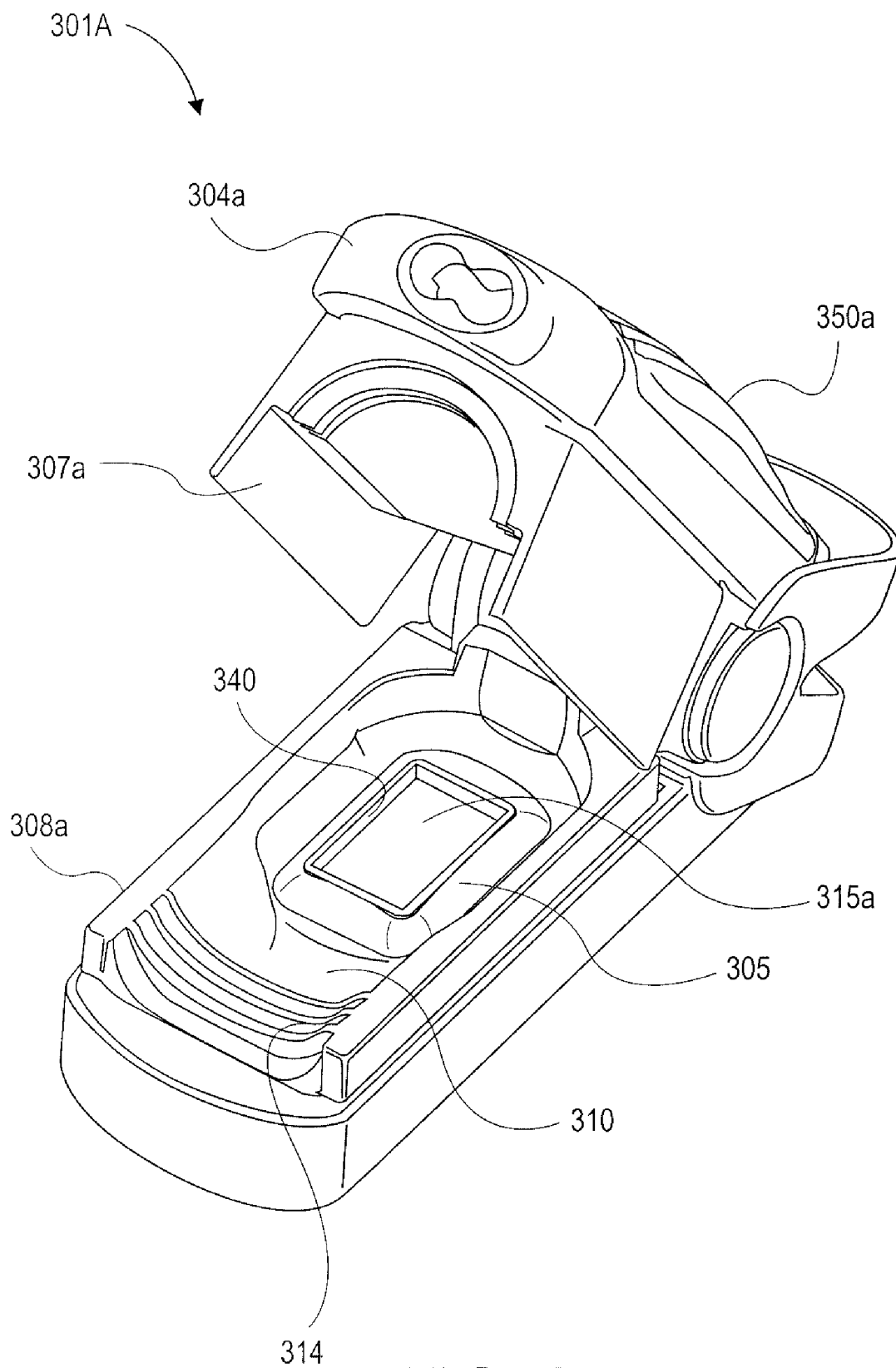
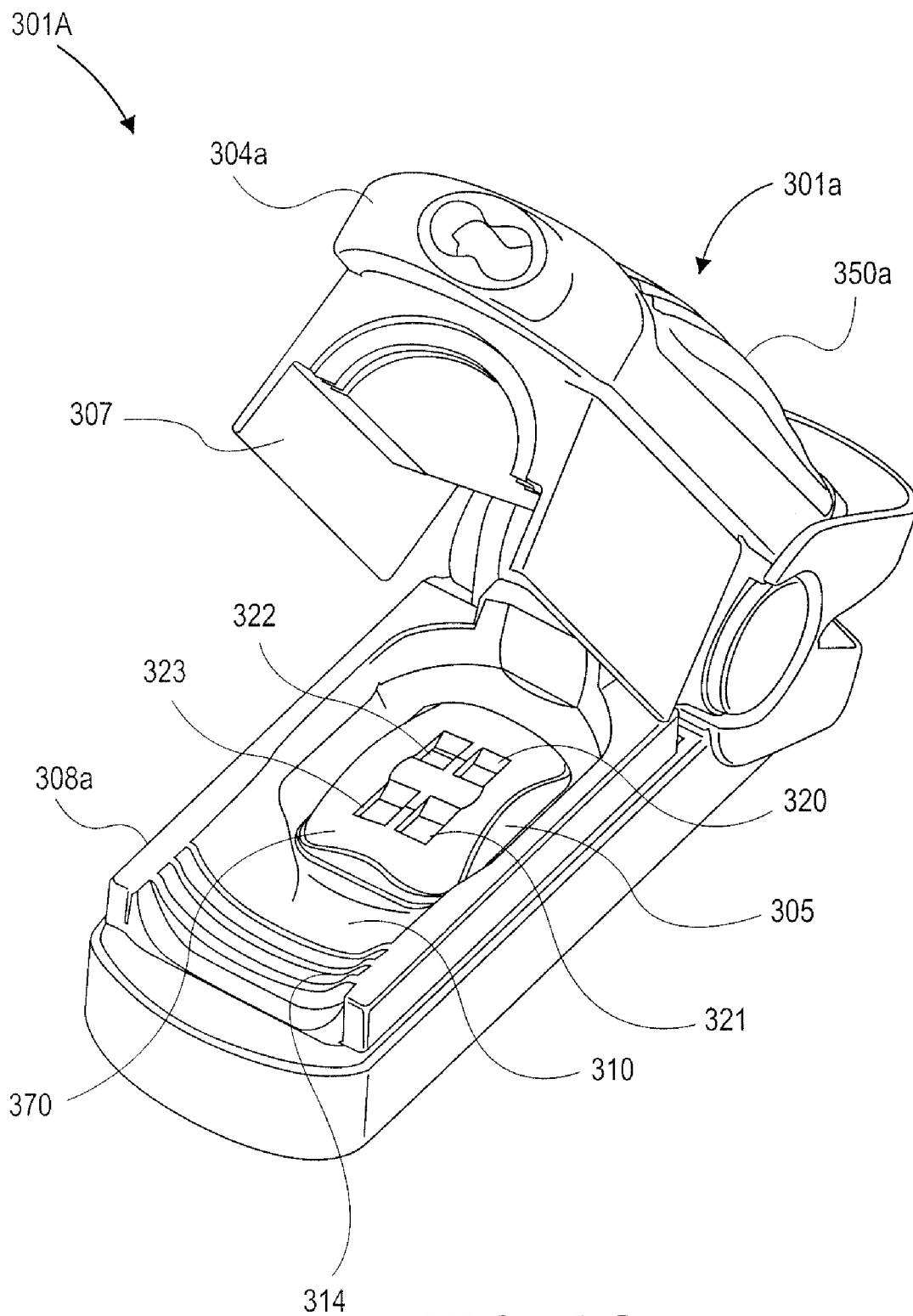


FIG. 3A

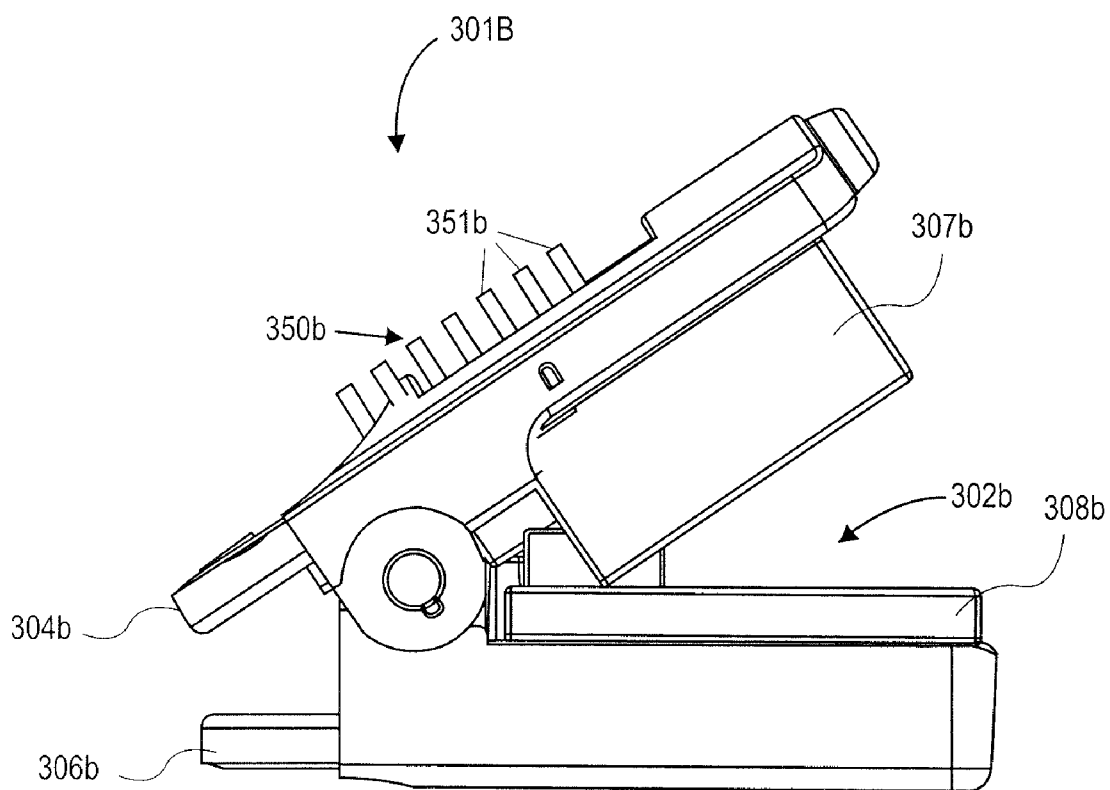


**FIG. 3B**

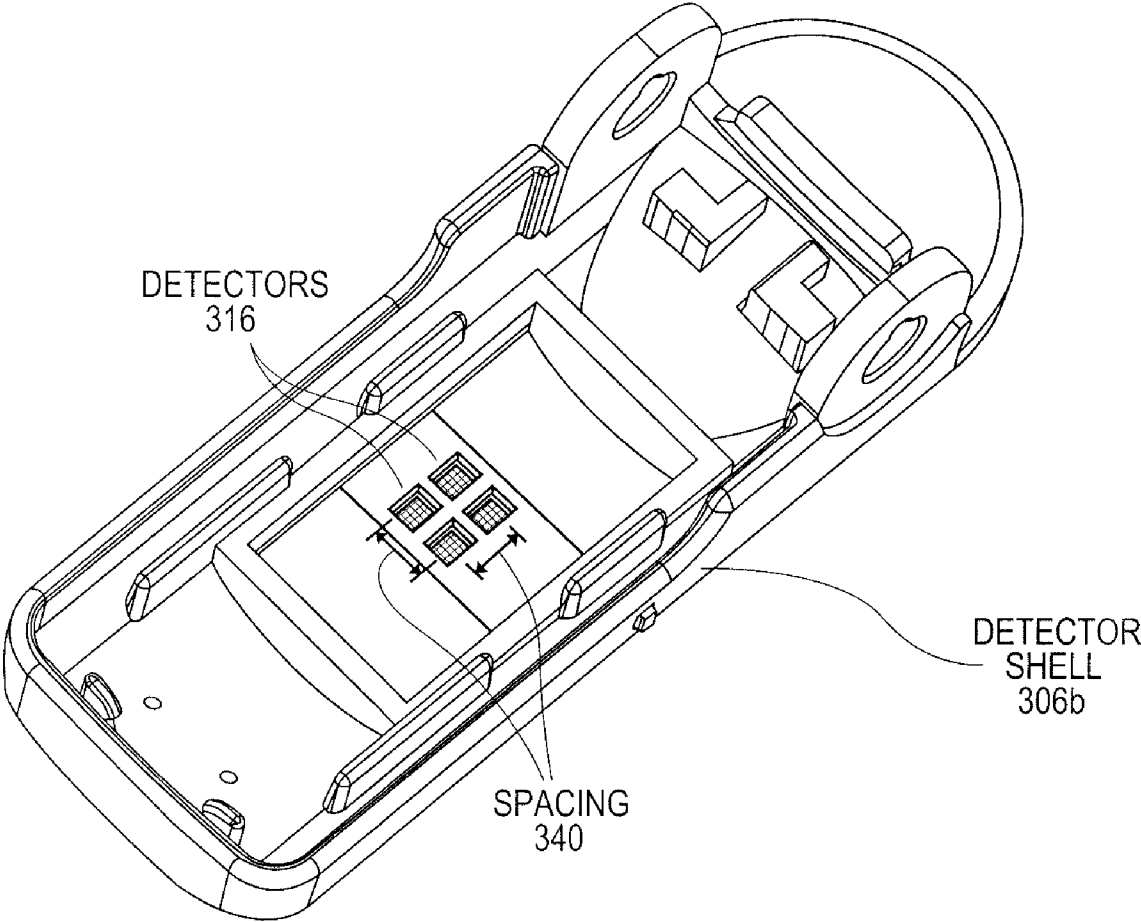




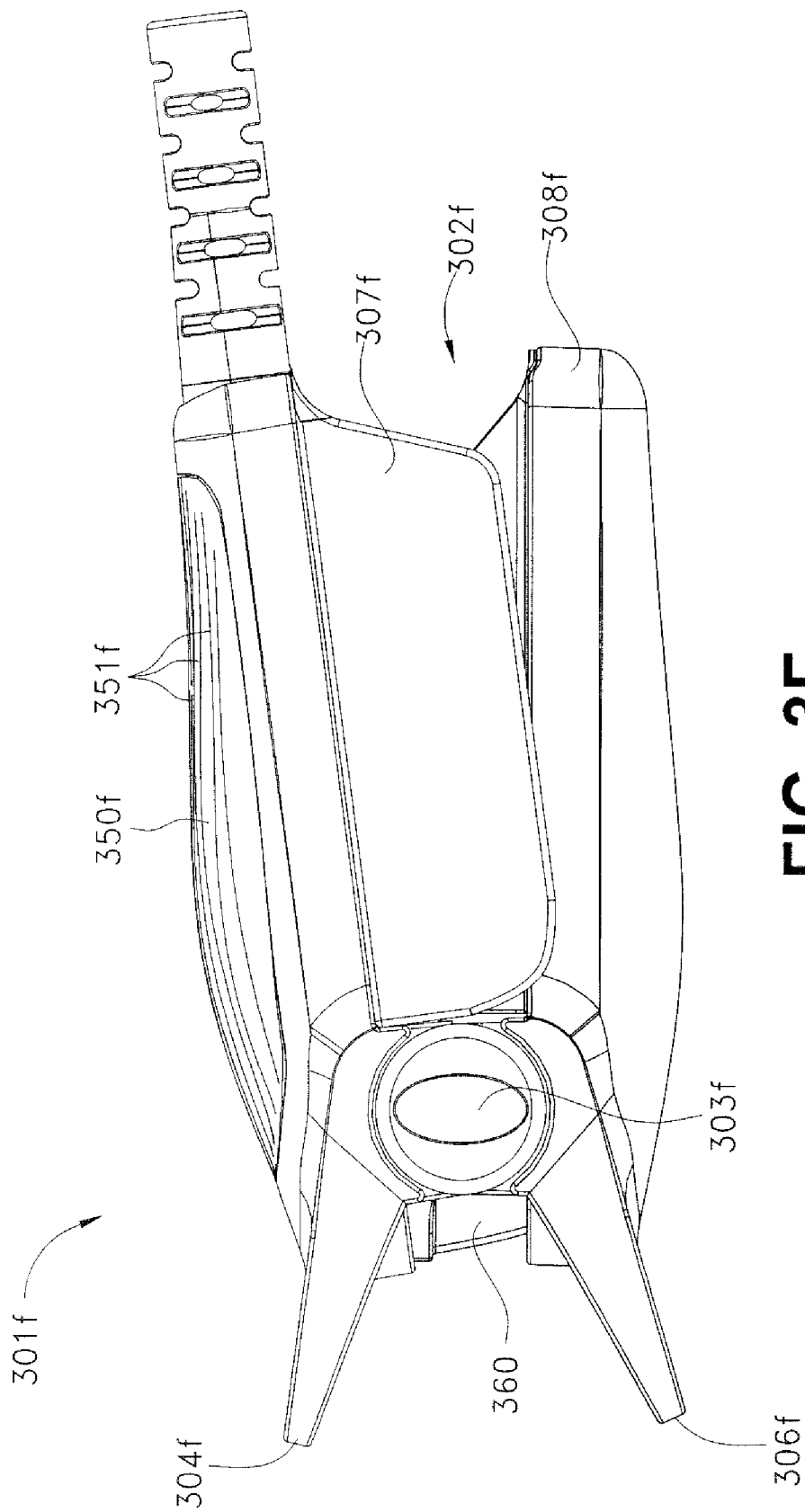
**FIG. 3C**



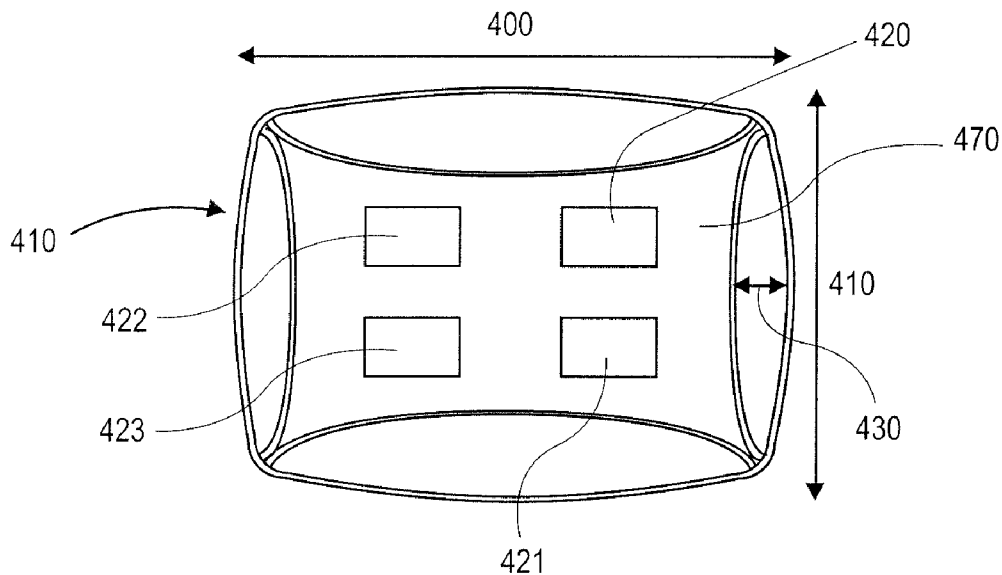
**FIG. 3D**



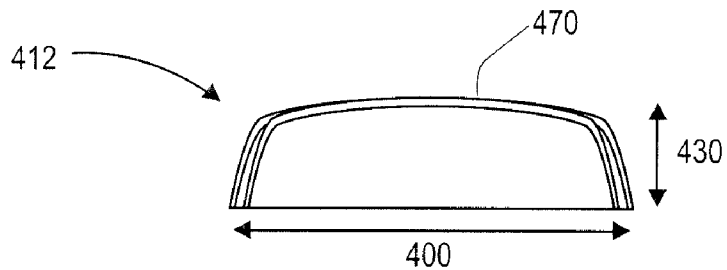
**FIG. 3E**



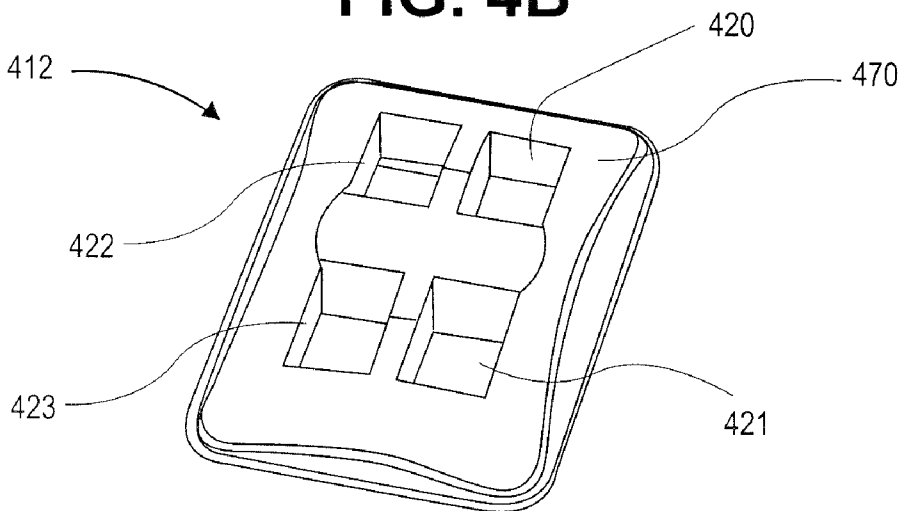
**FIG. 3F**



**FIG. 4A**



**FIG. 4B**



**FIG. 4C**

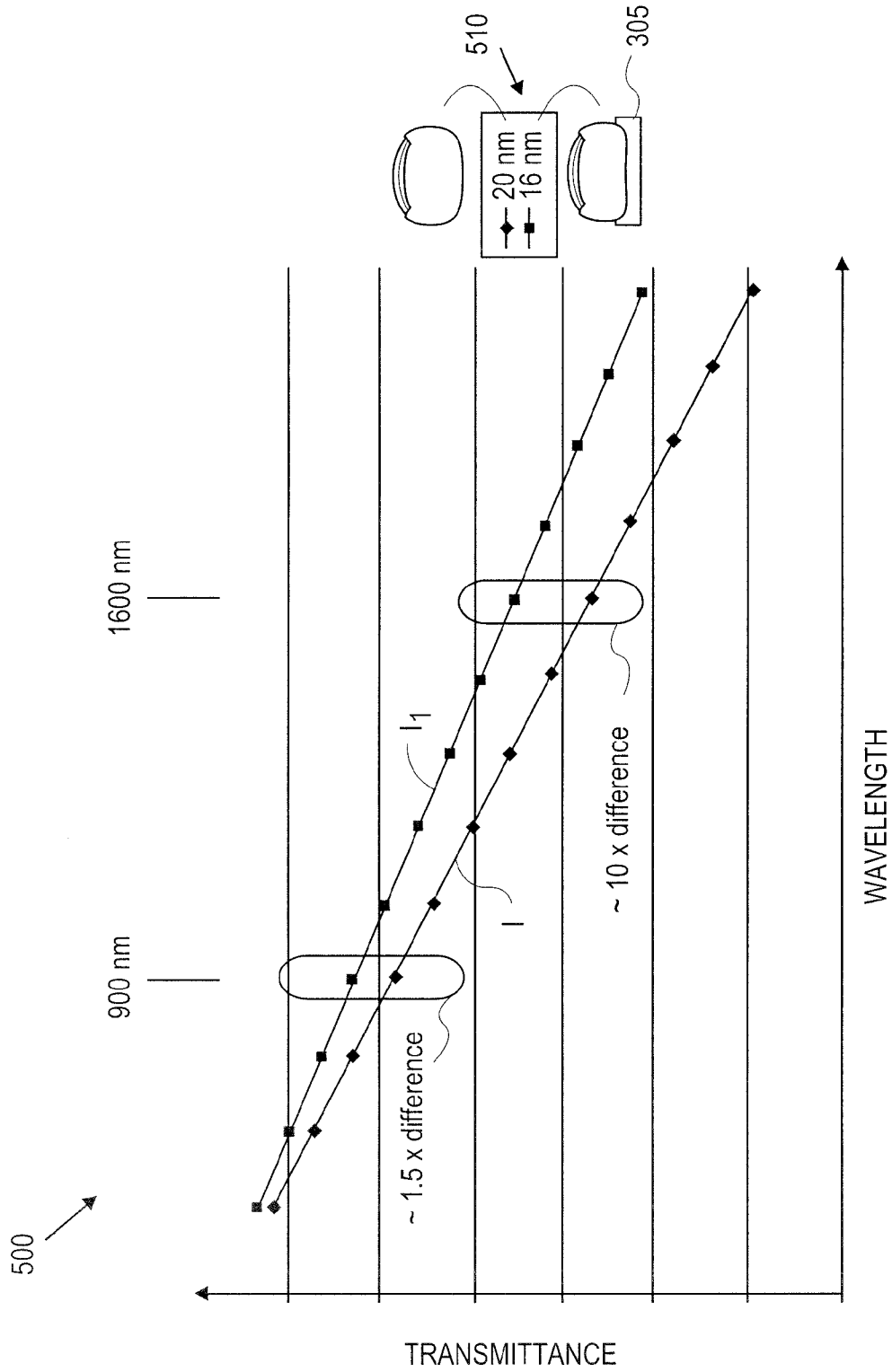
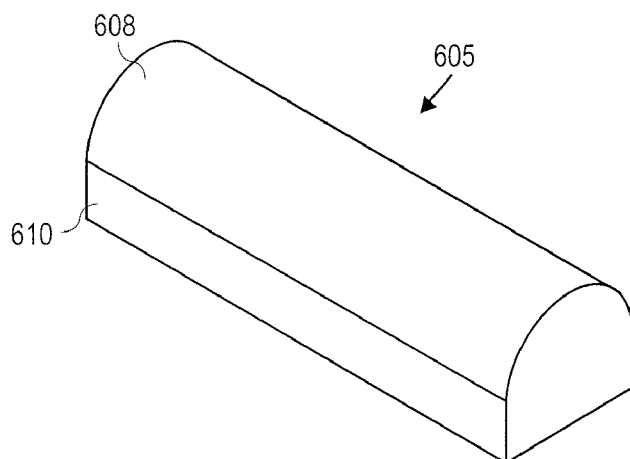
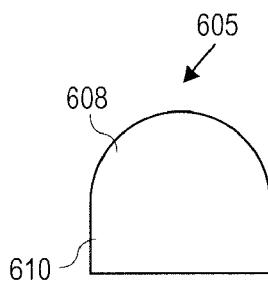


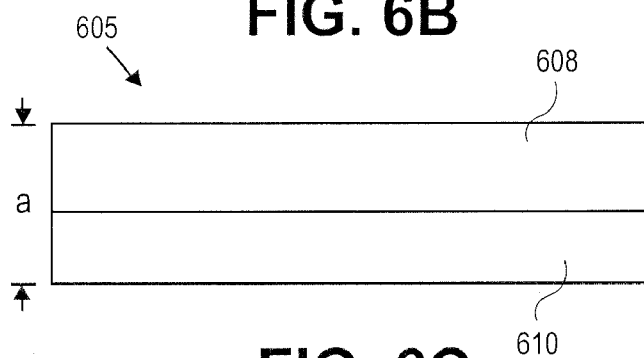
FIG. 5



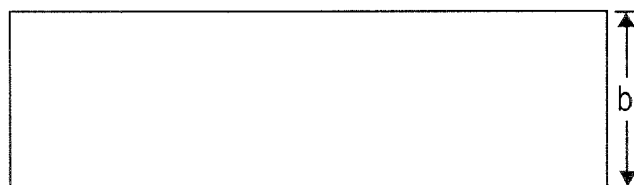
**FIG. 6A**



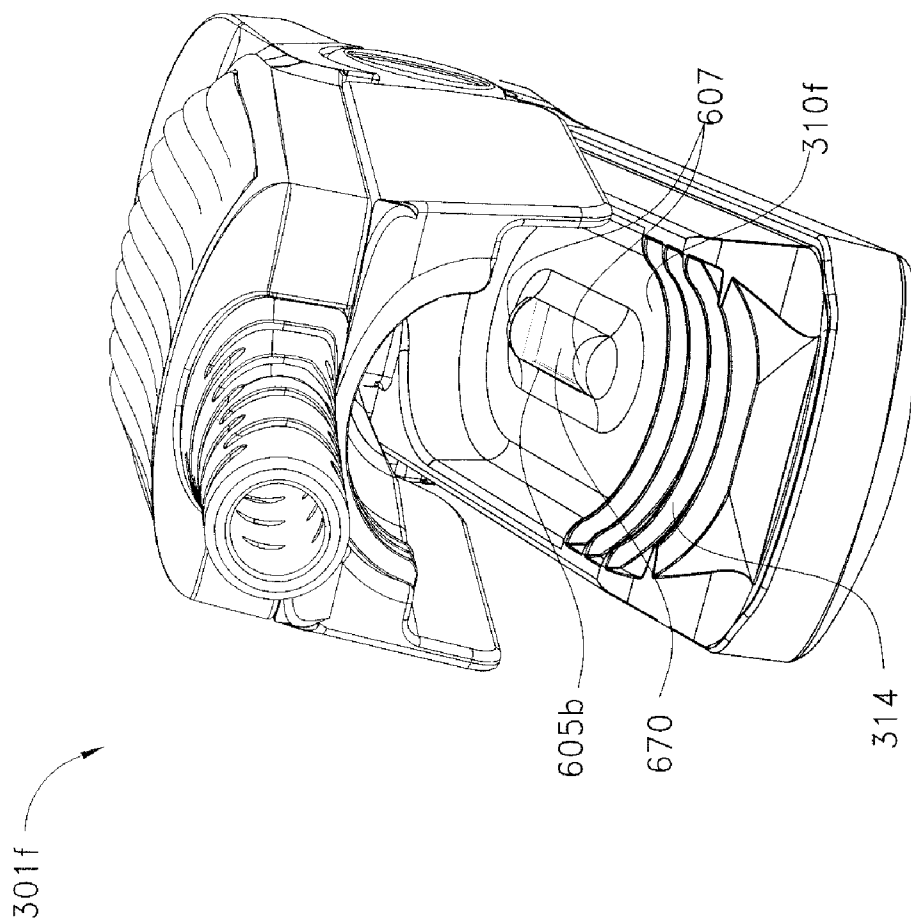
**FIG. 6B**



**FIG. 6C**

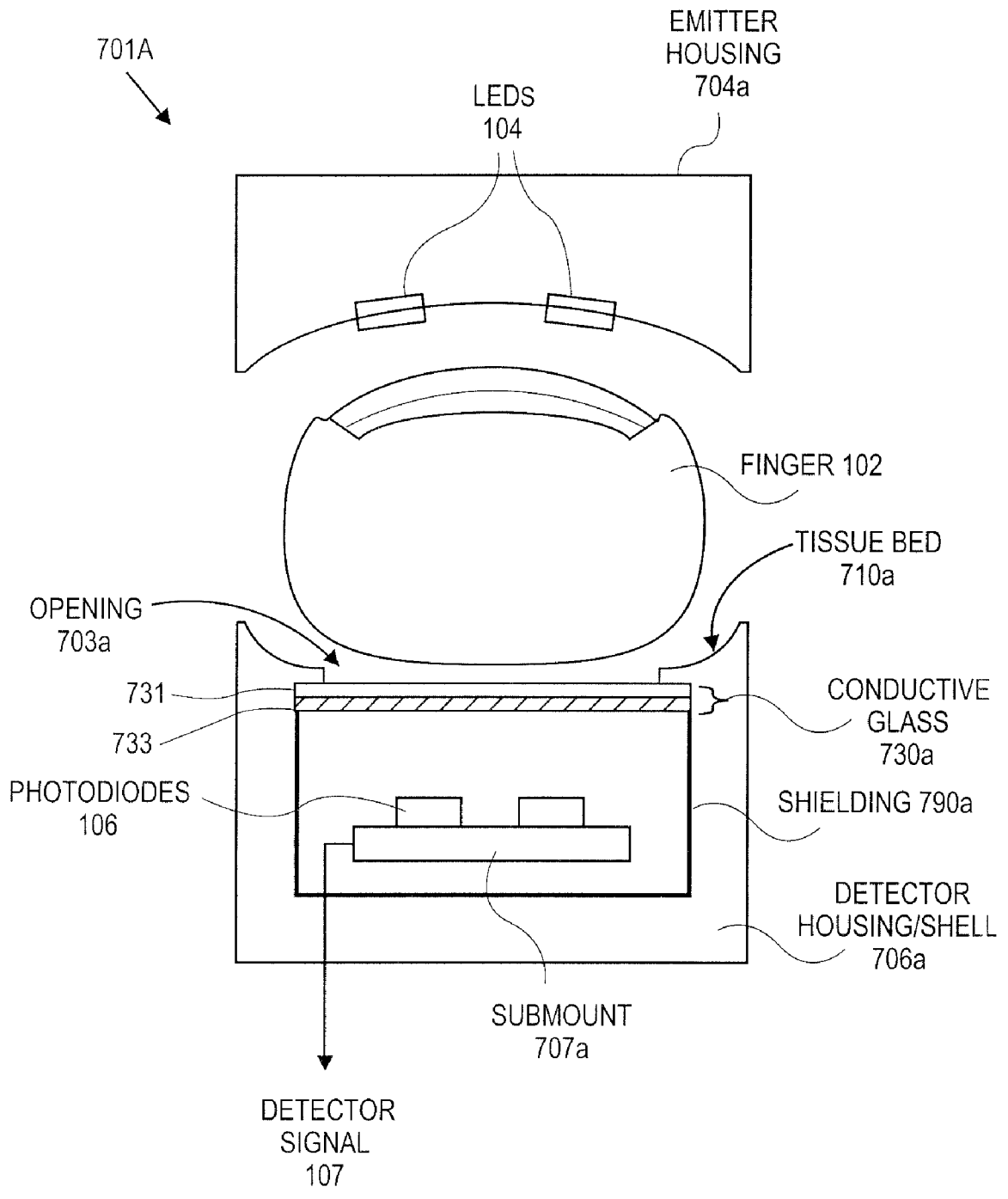


**FIG. 6D**



**FIG. 6E**





**FIG. 7A**

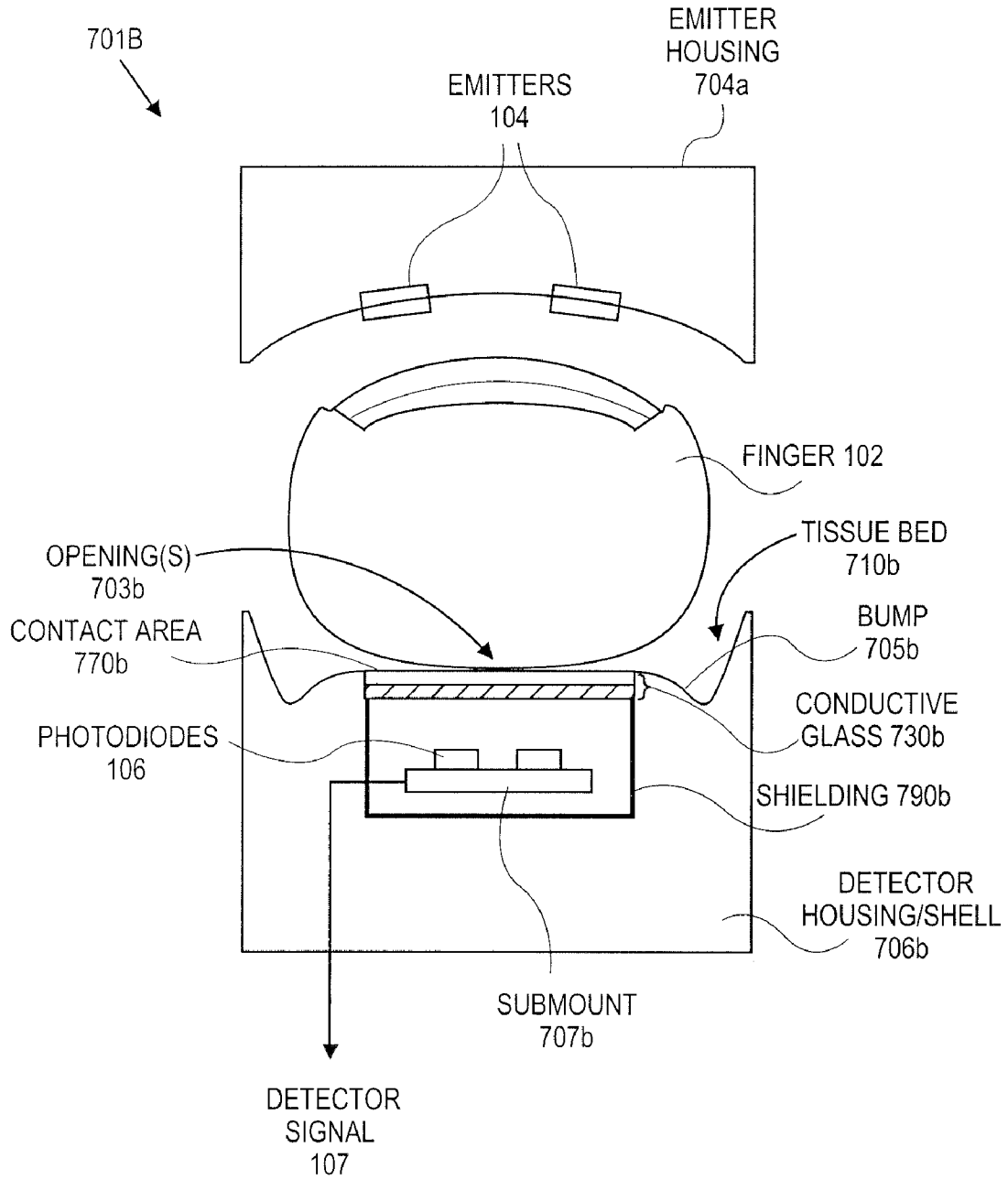


FIG. 7B

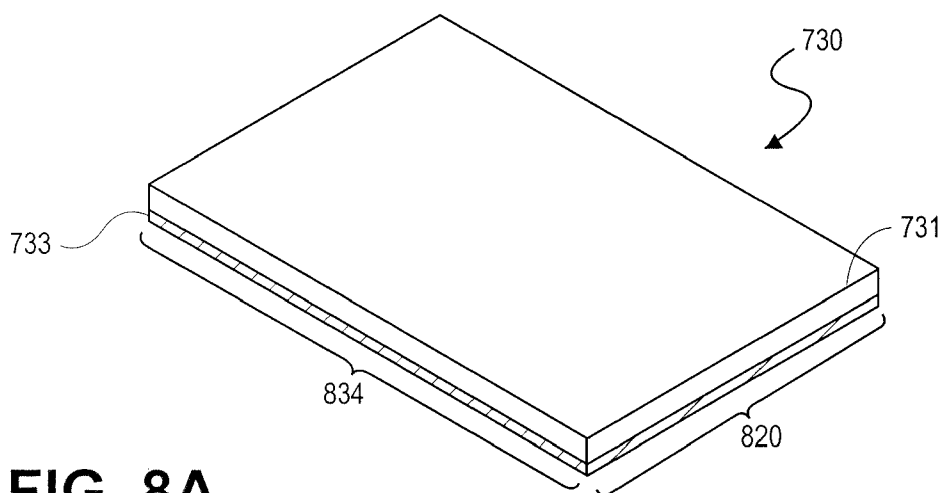


FIG. 8A

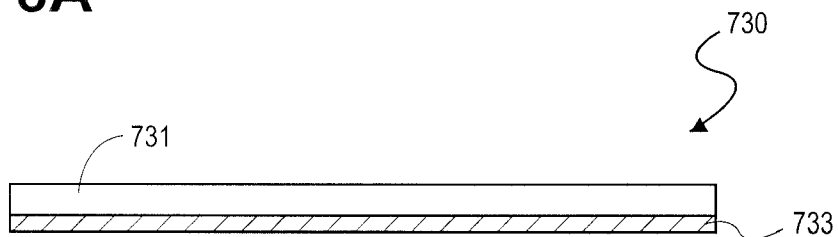


FIG. 8B

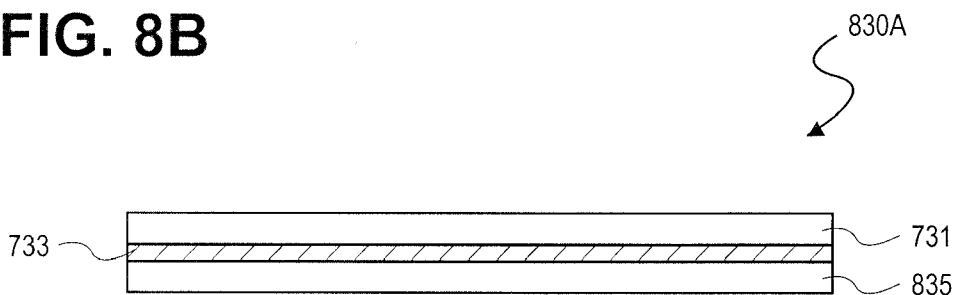


FIG. 8C

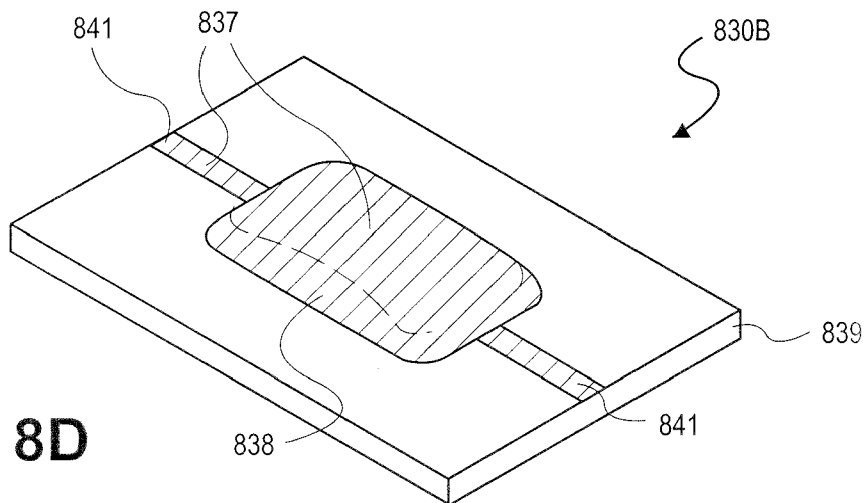


FIG. 8D

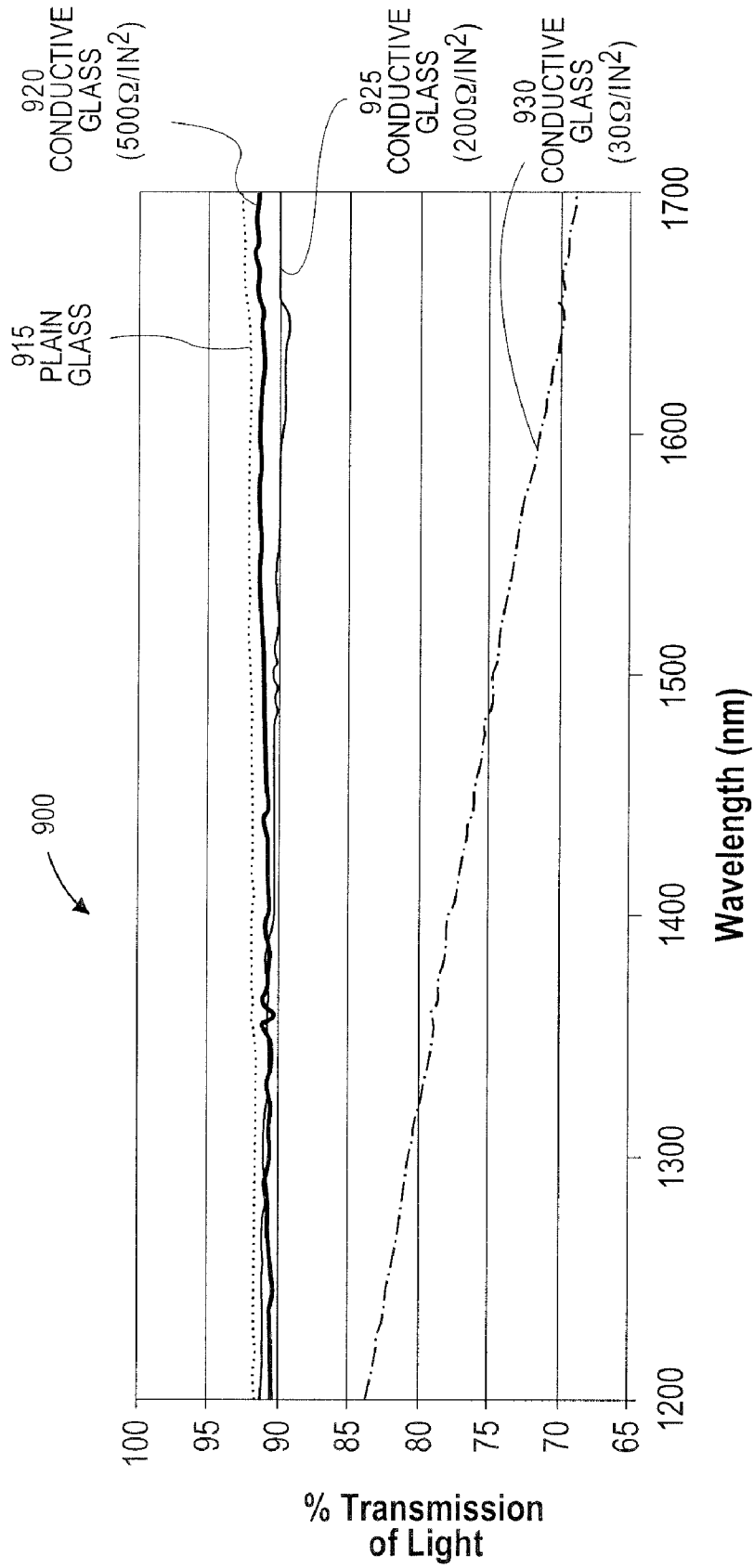
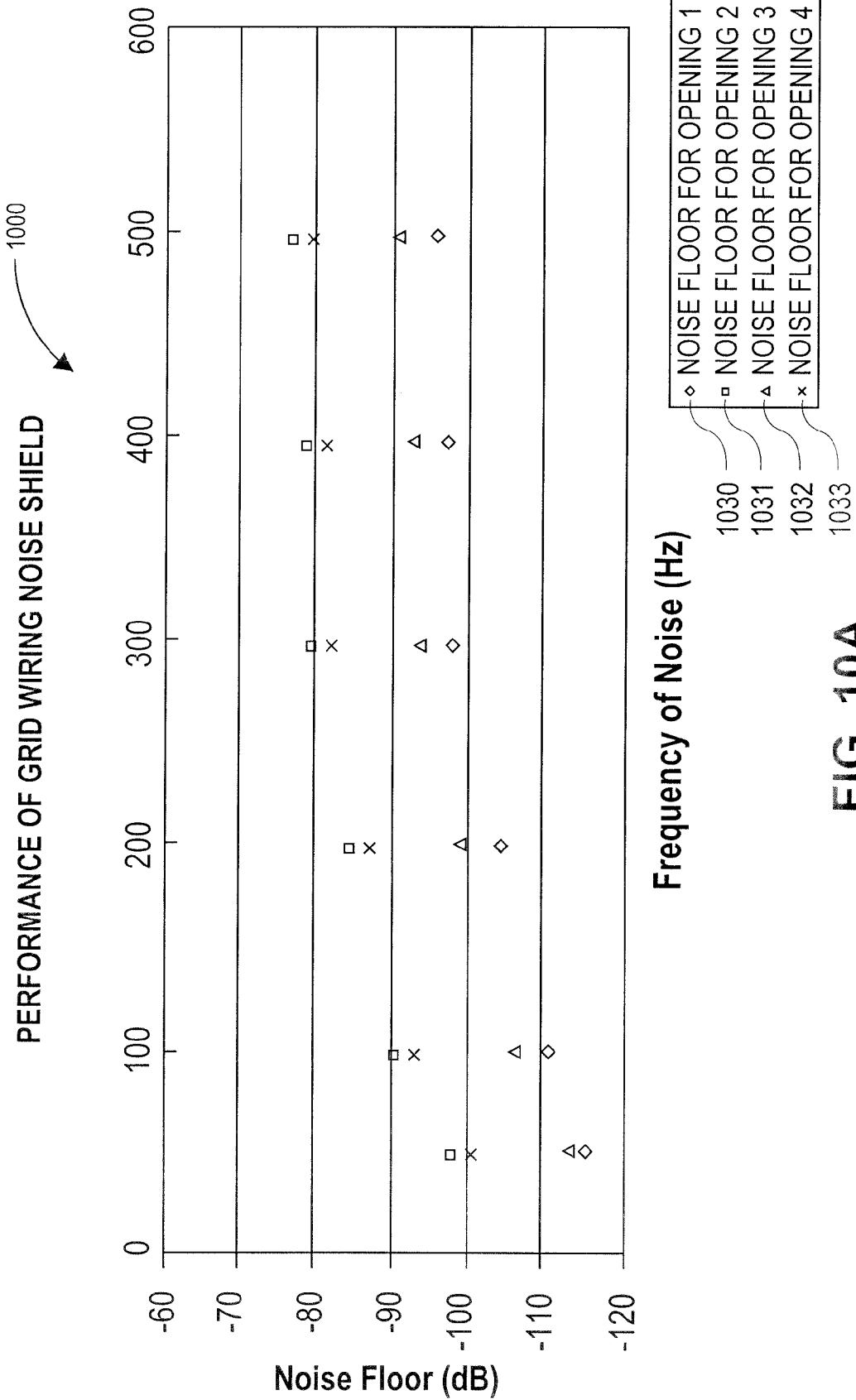
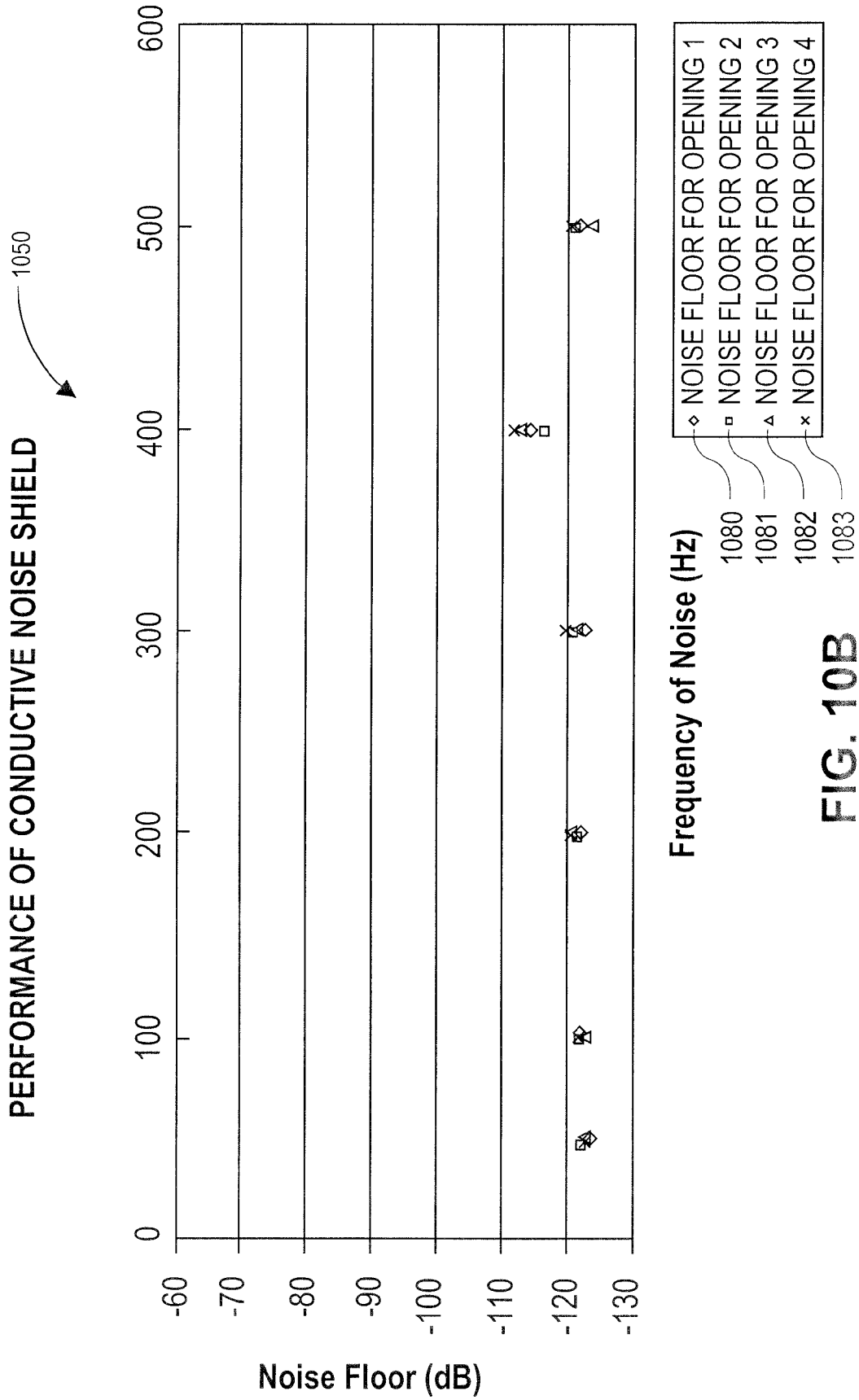
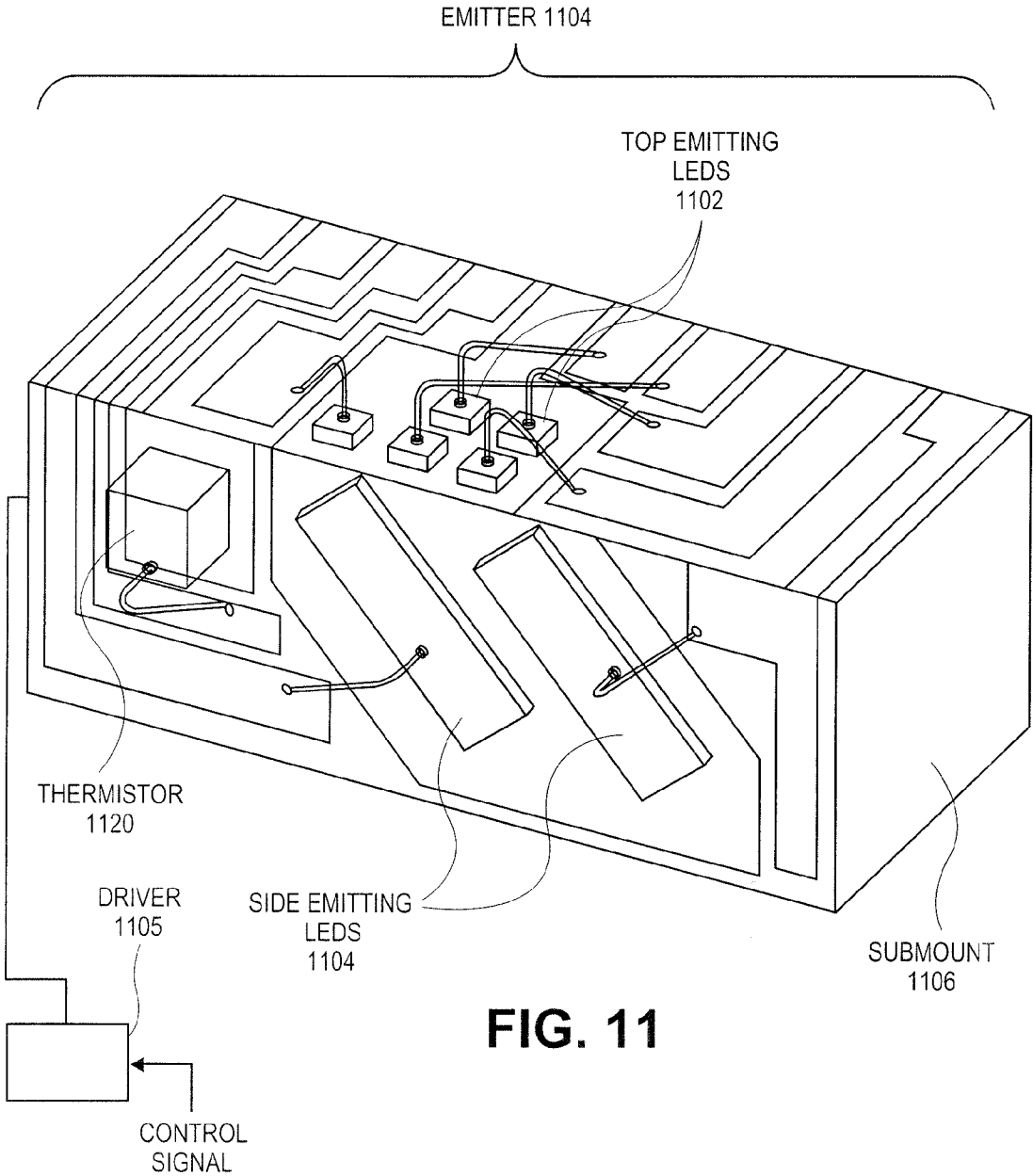


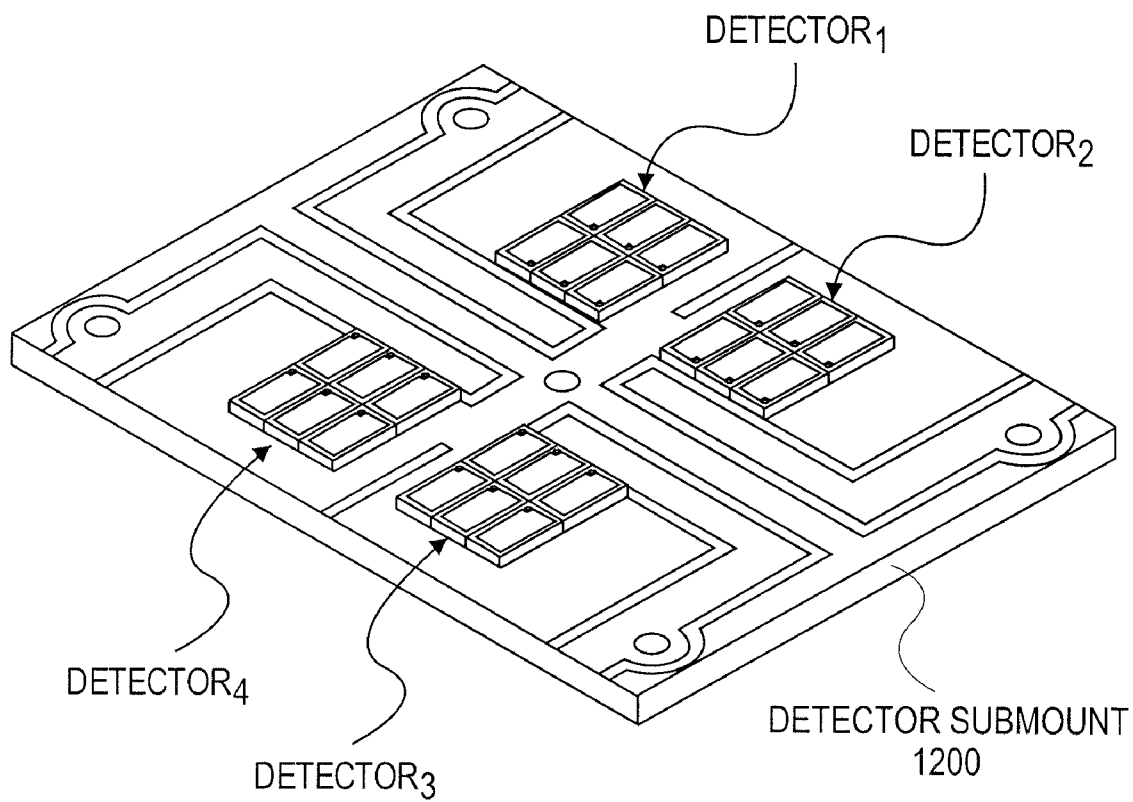
FIG. 9



**FIG. 10A**







**FIG. 12**



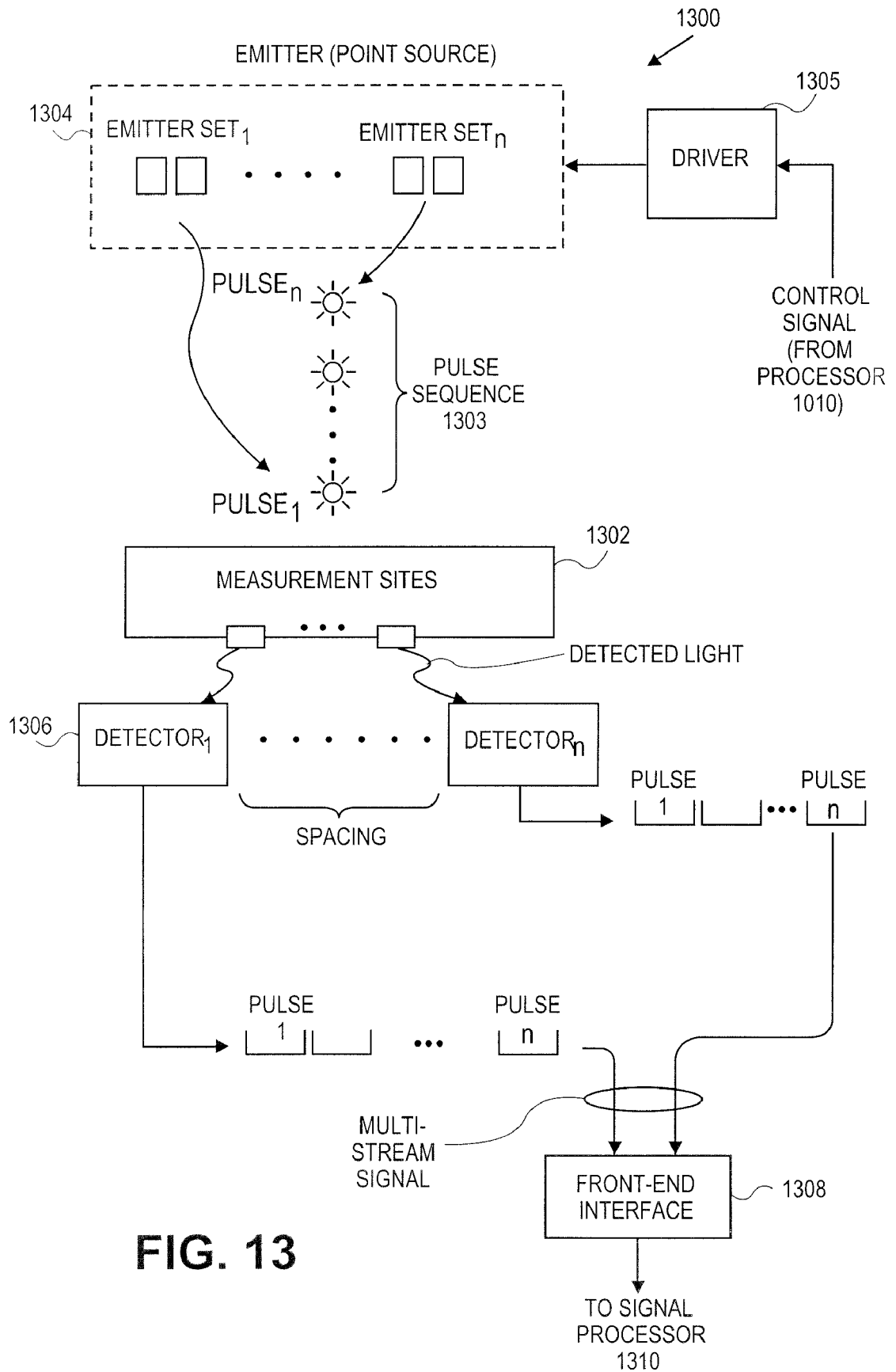
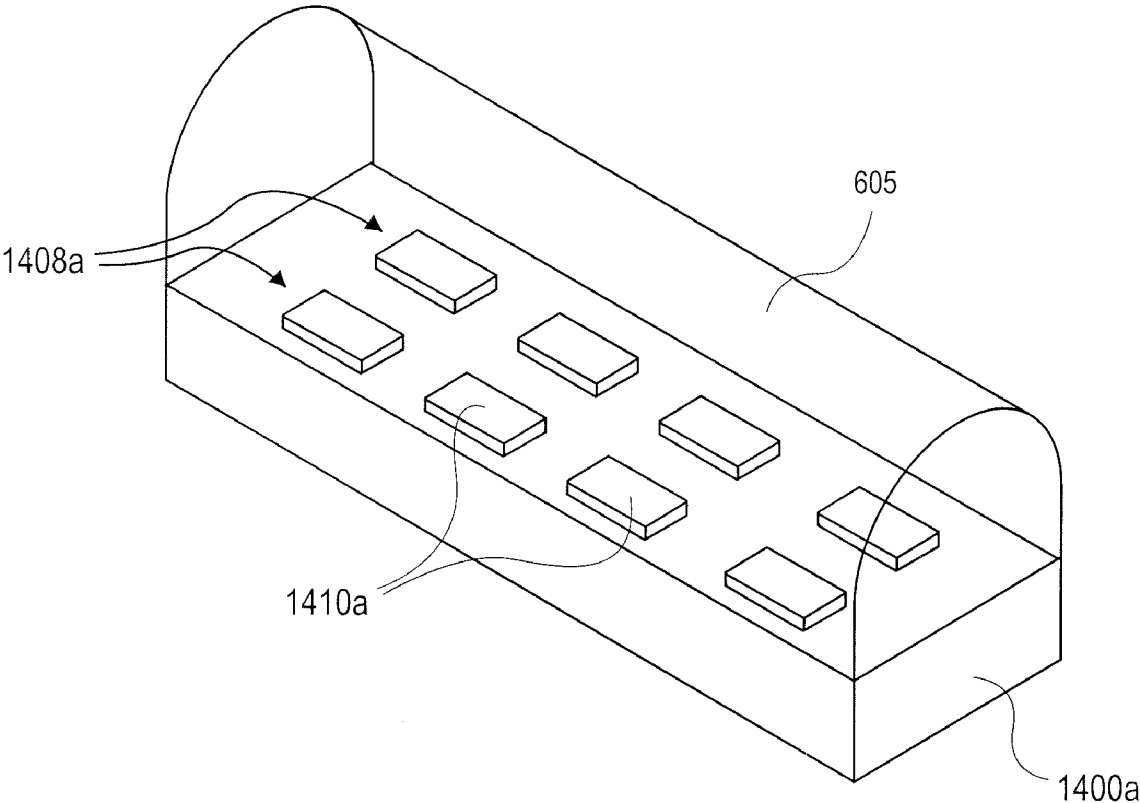
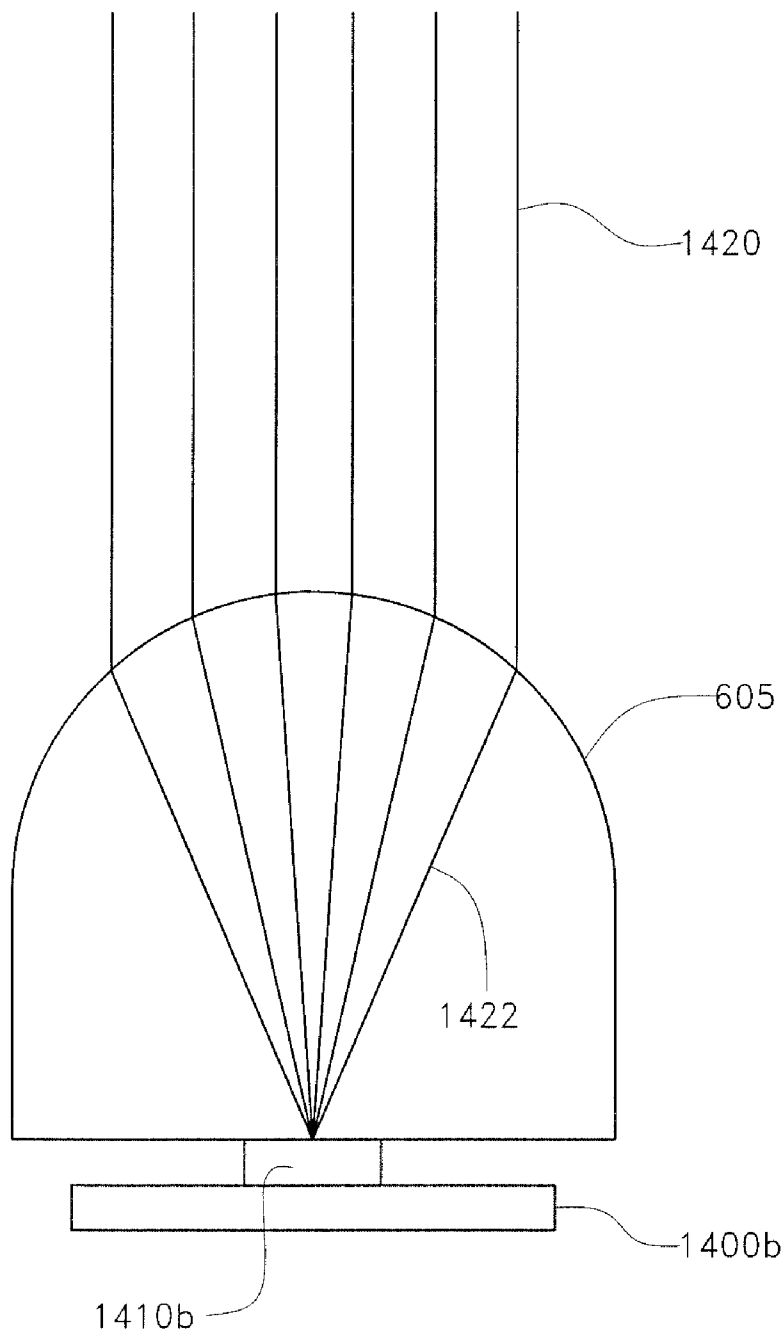


FIG. 13

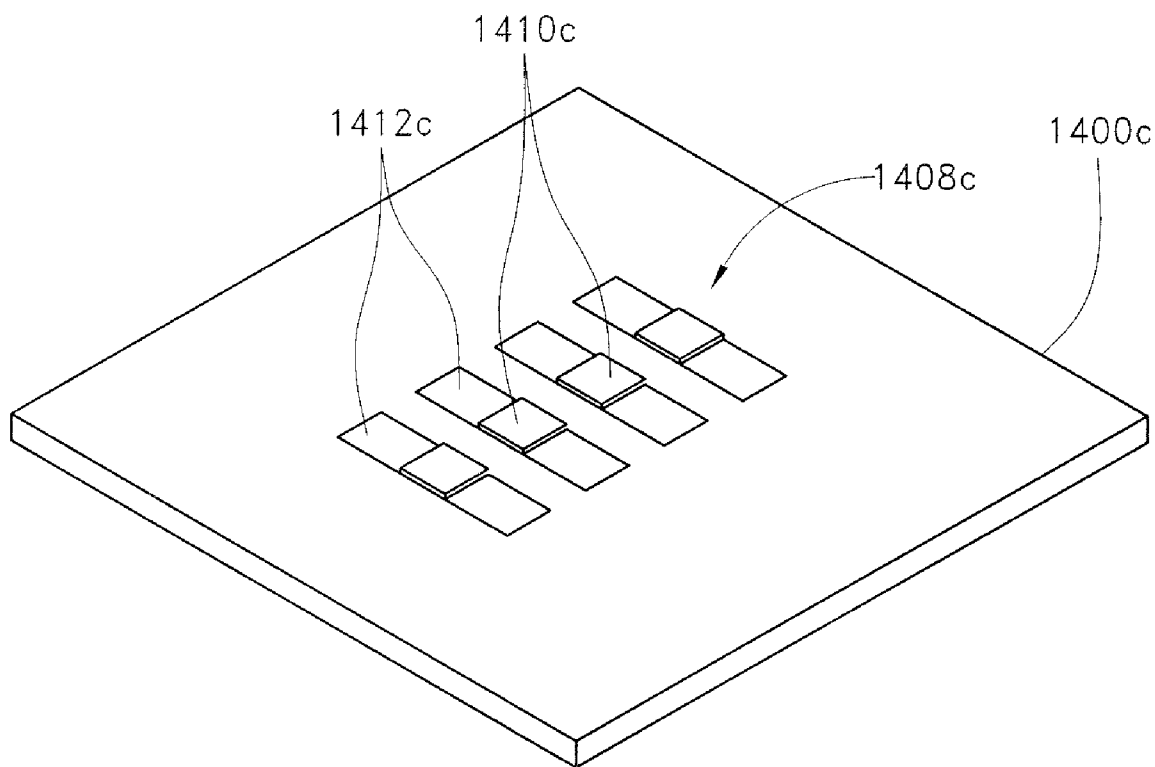


**FIG. 14A**

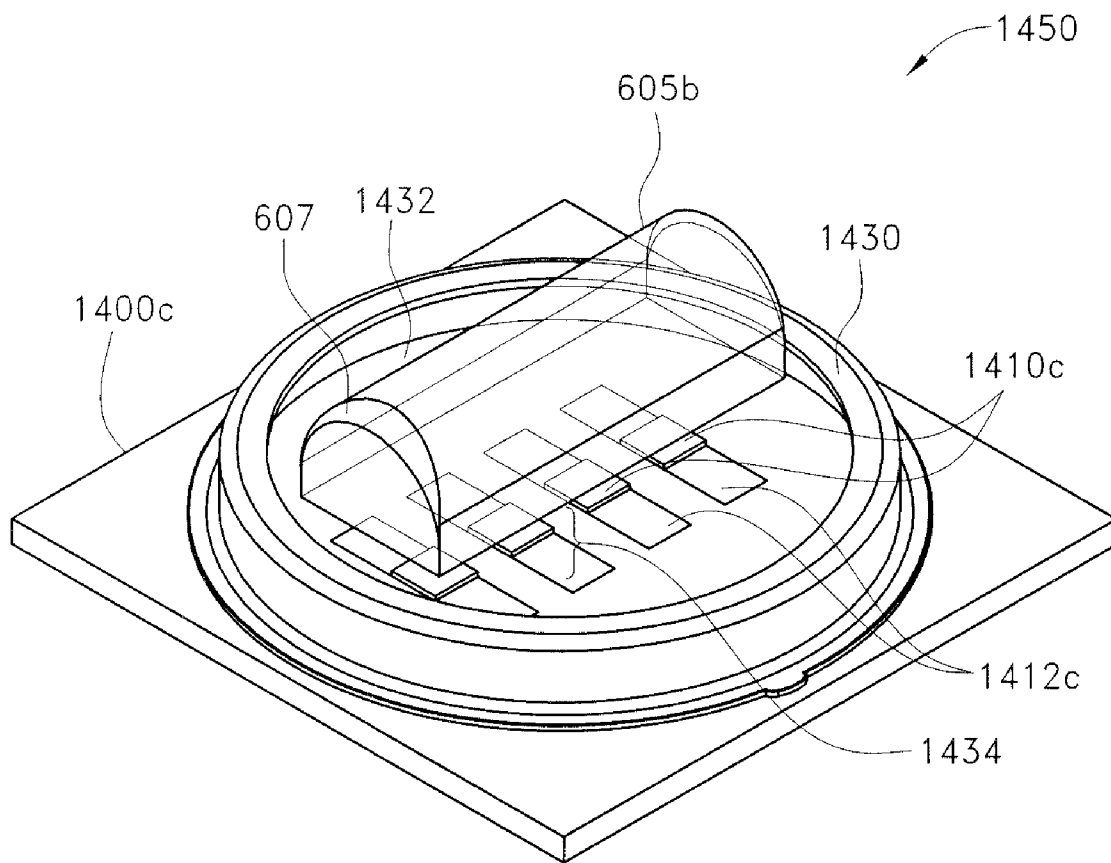
FROM EMITTERS



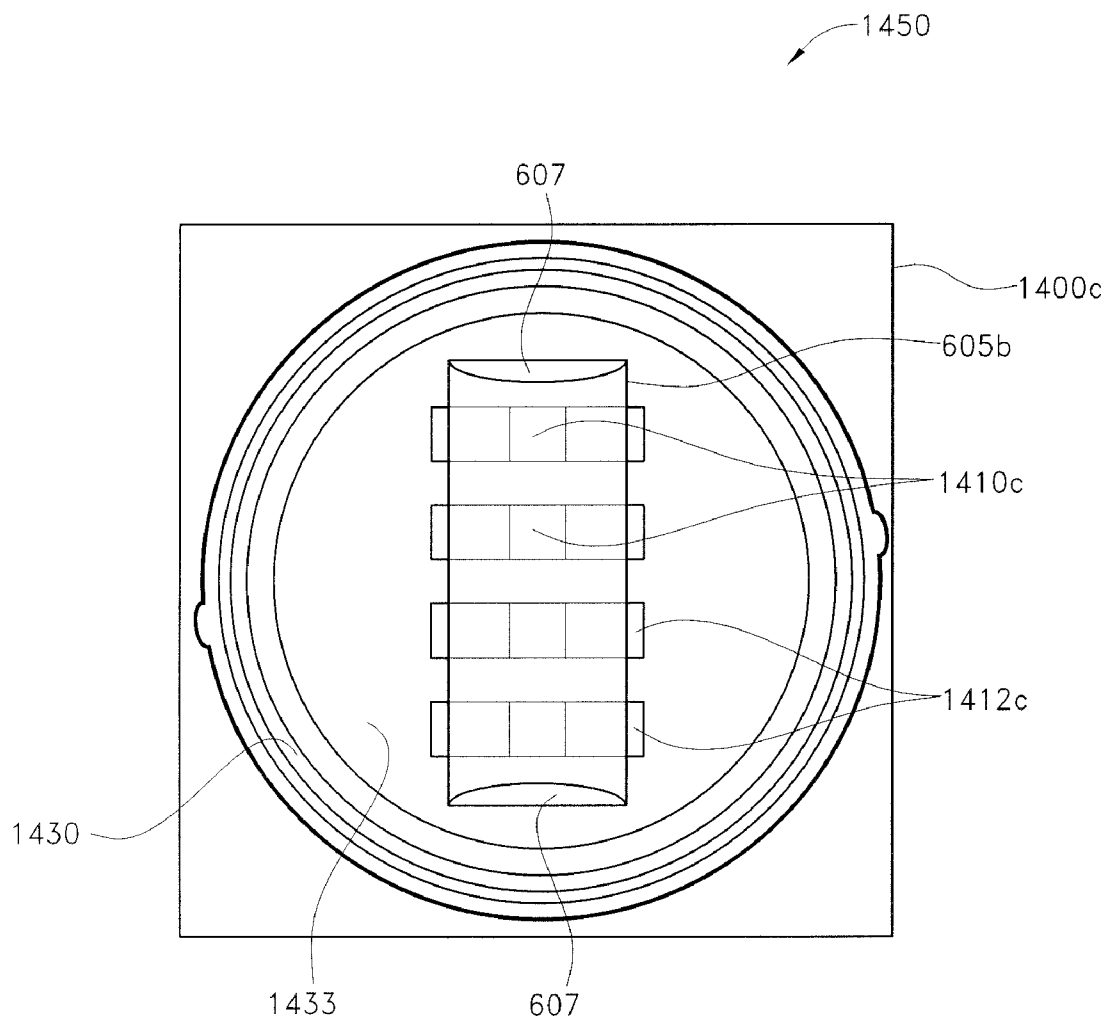
**FIG. 14B**



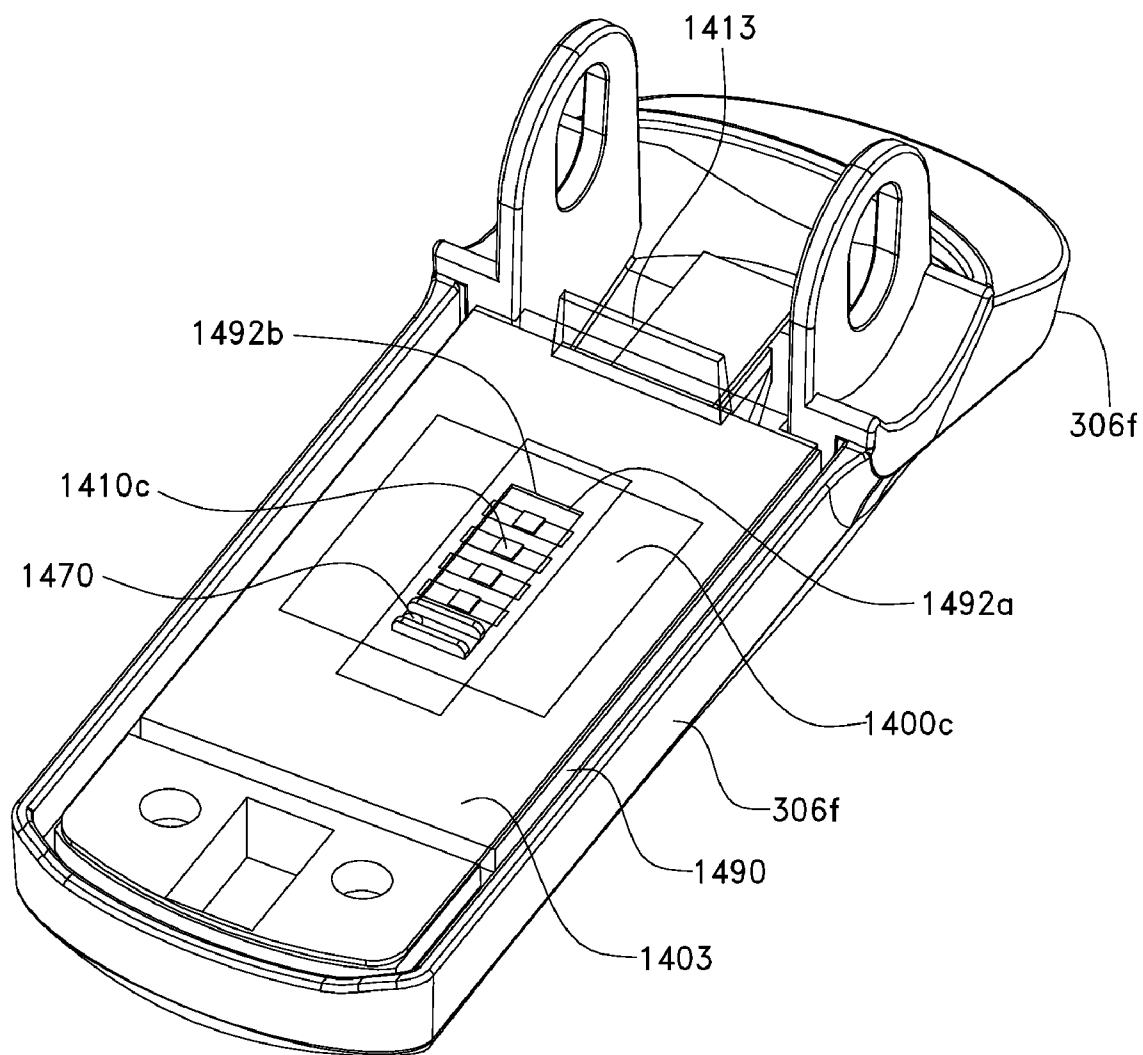
**FIG. 14C**



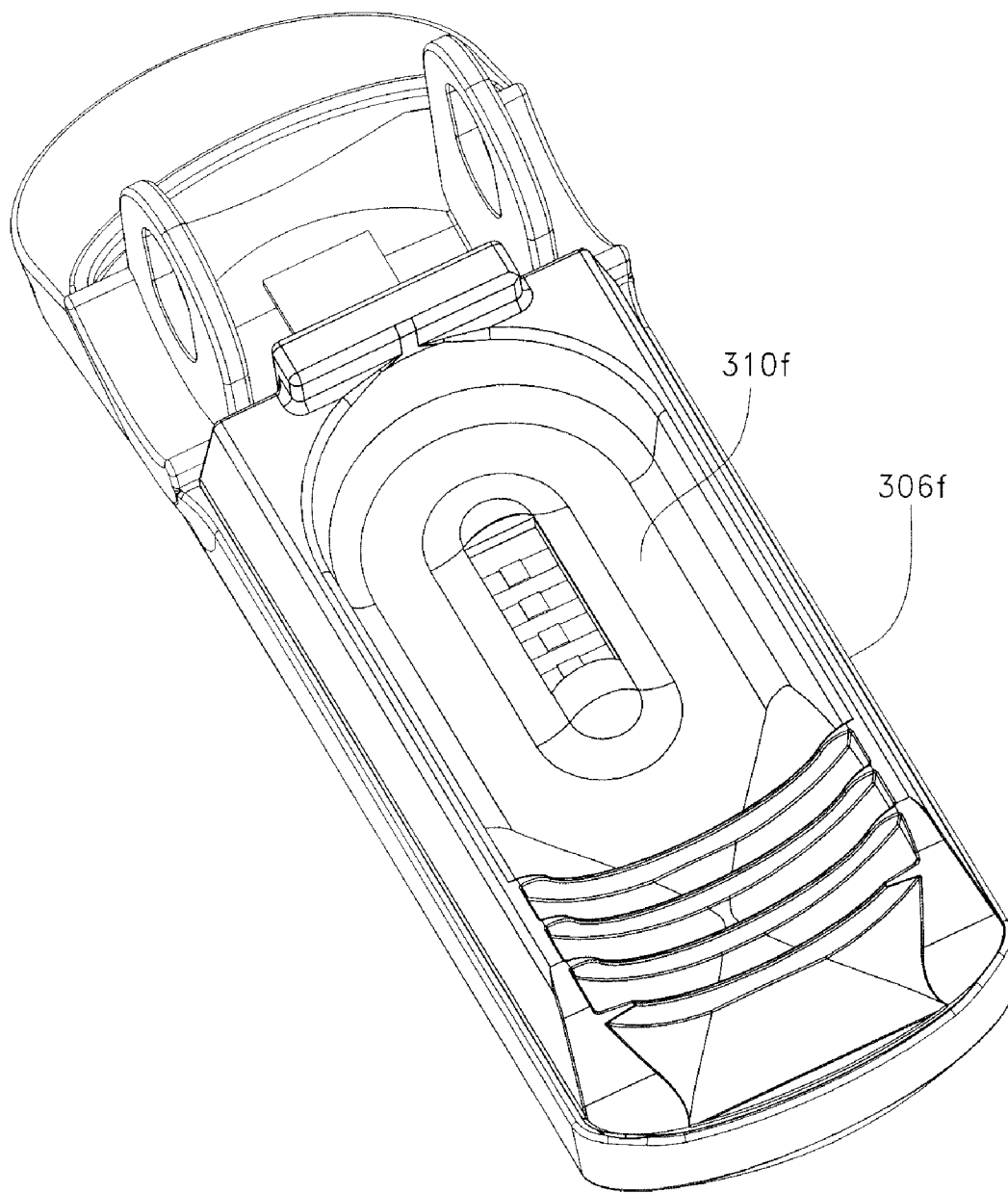
**FIG. 14D**



**FIG. 14E**

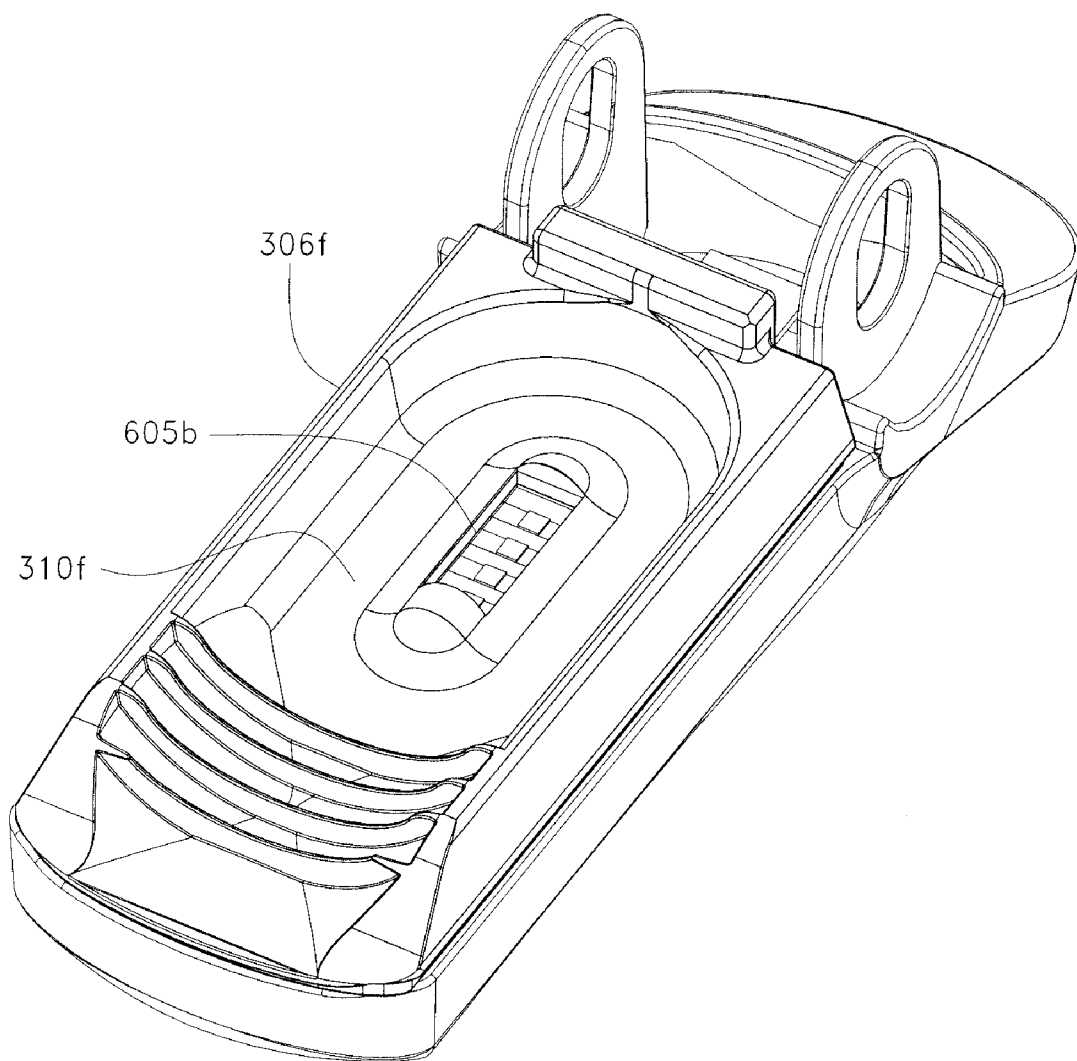


**FIG. 14F**

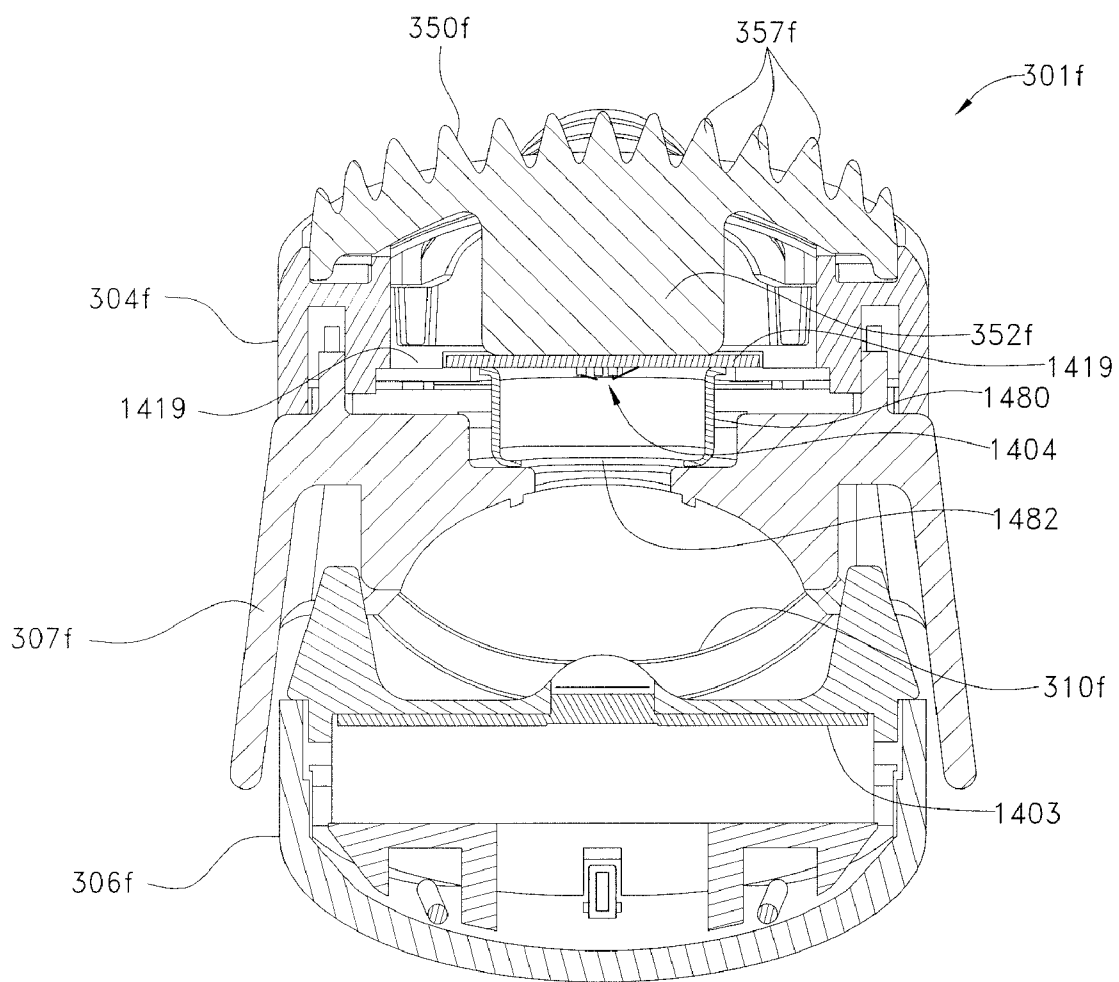


**FIG. 14G**

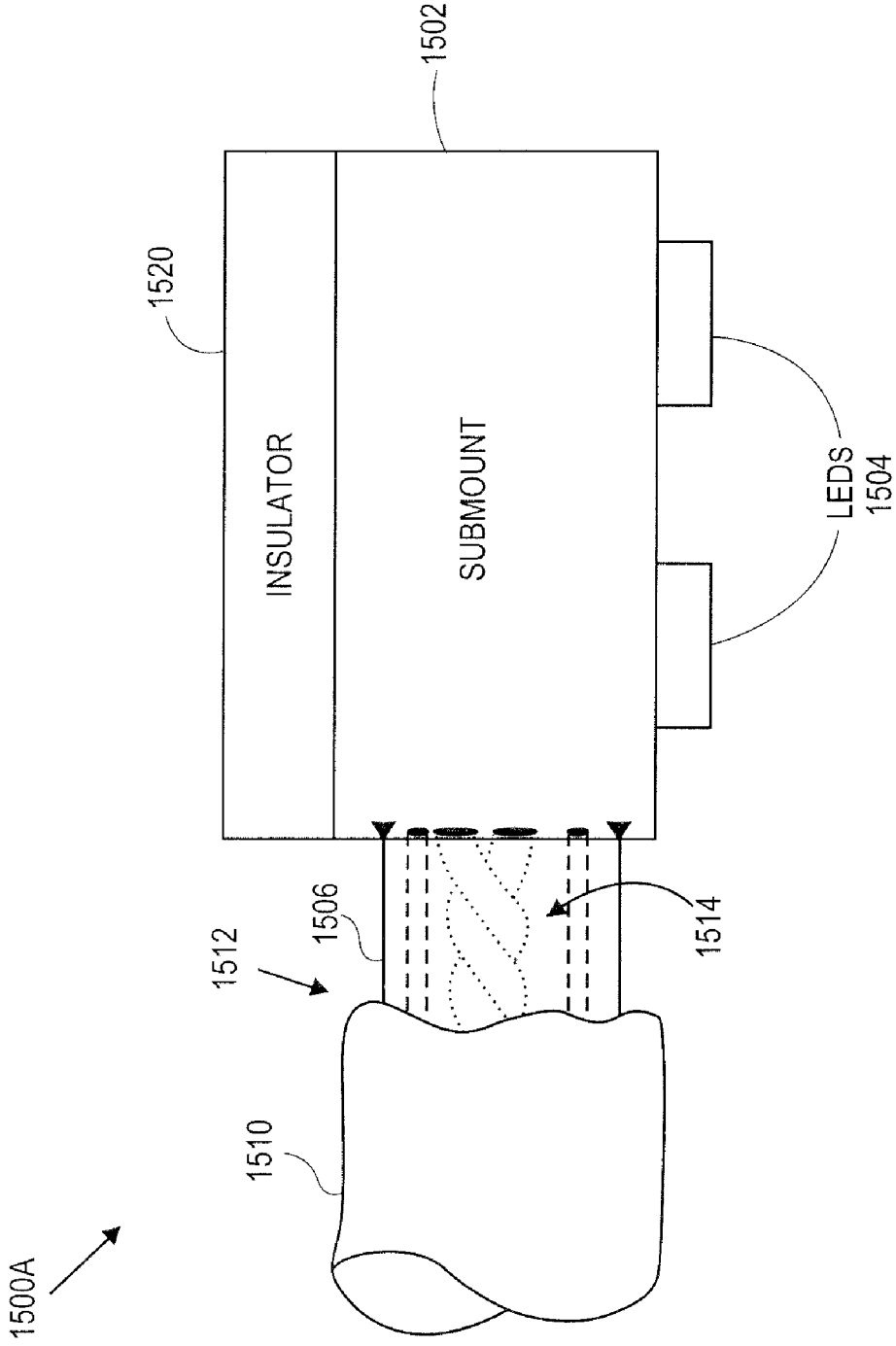




**FIG. 14H**



**FIG. 14I**



**FIG. 15A**

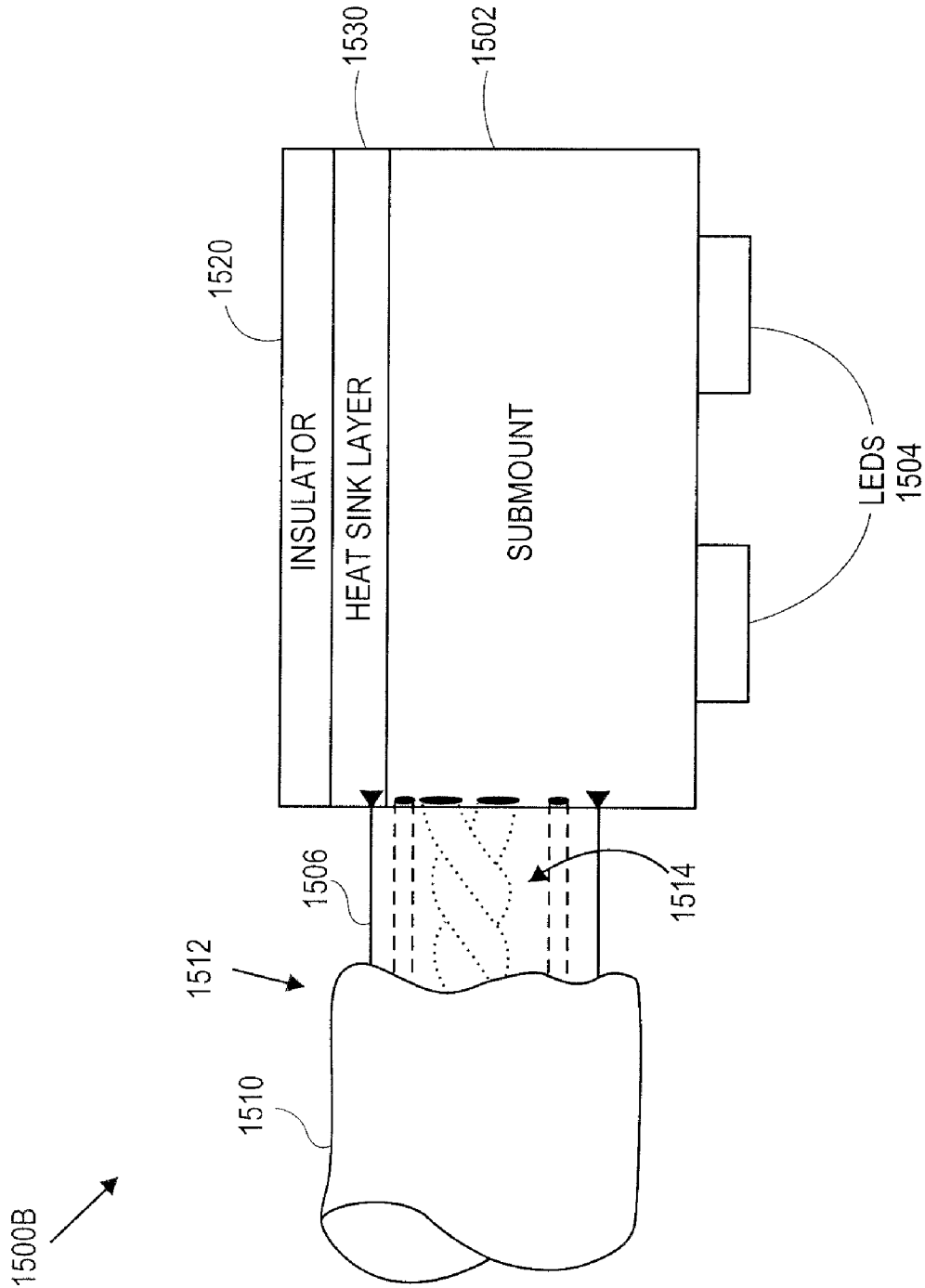


FIG. 15B

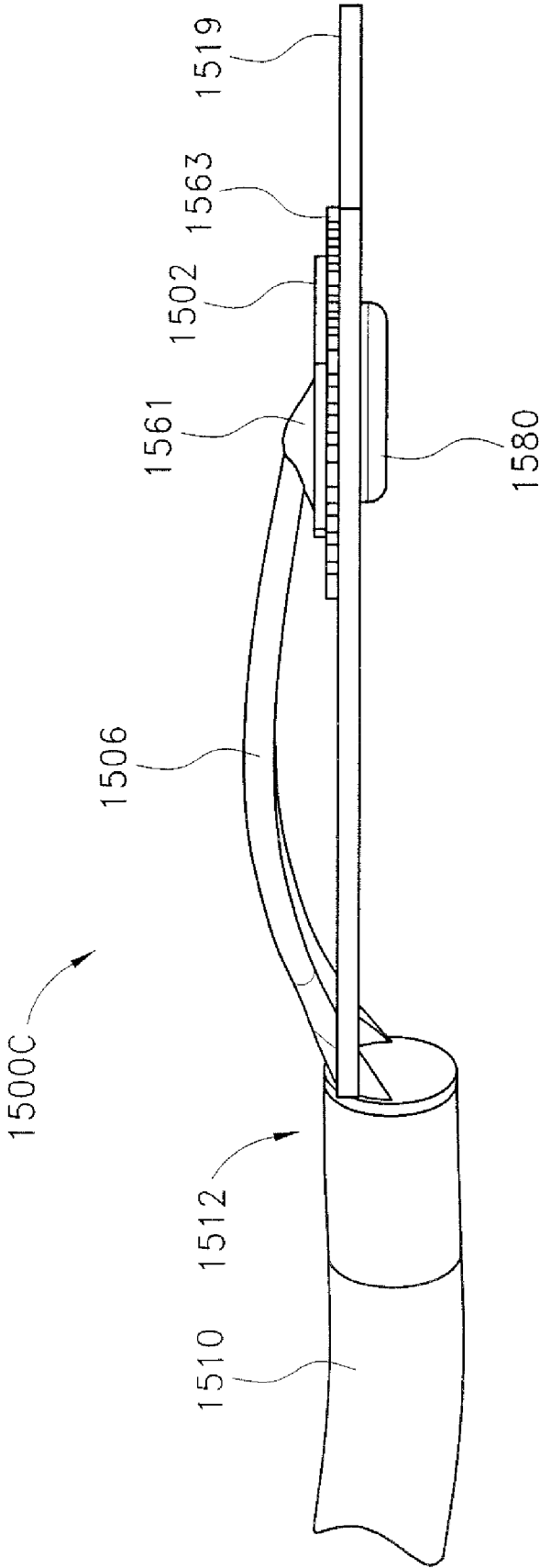


FIG. 150C

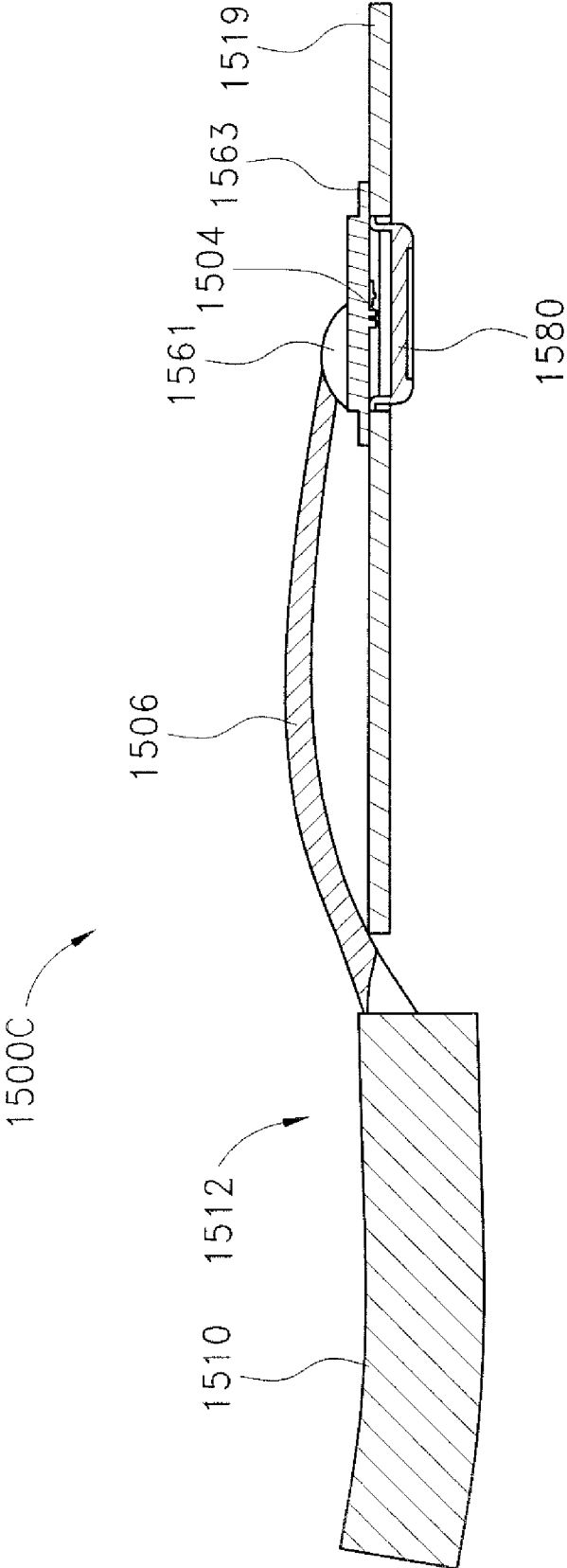


FIG. 15D

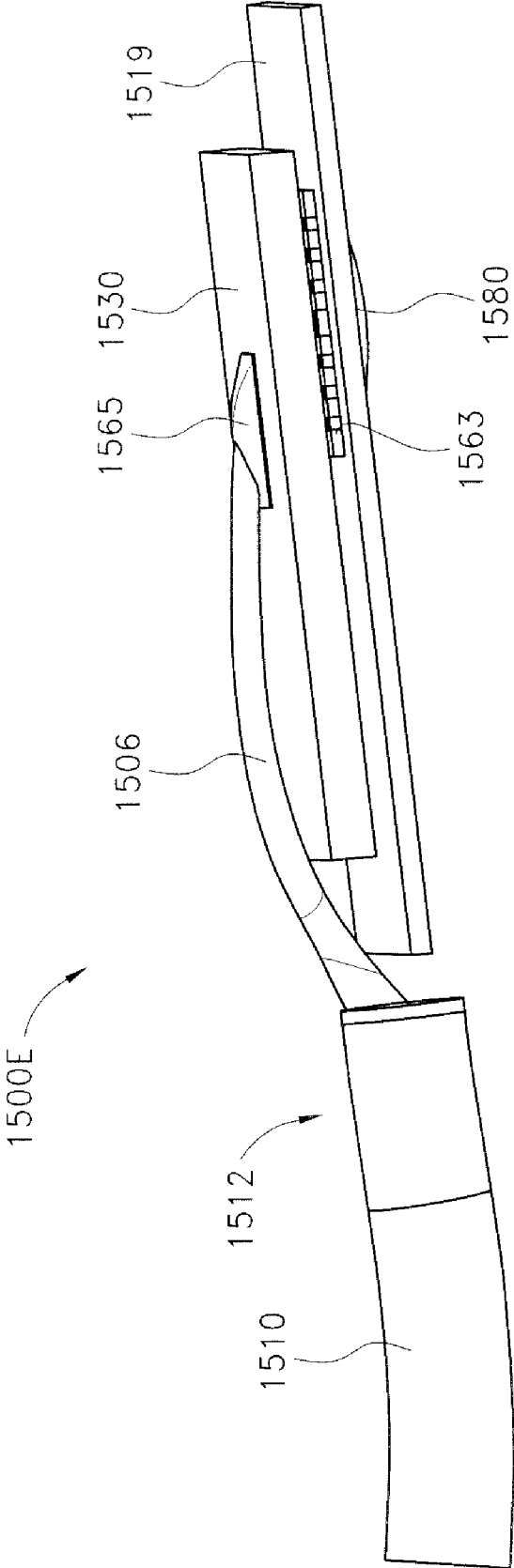


FIG. 15E

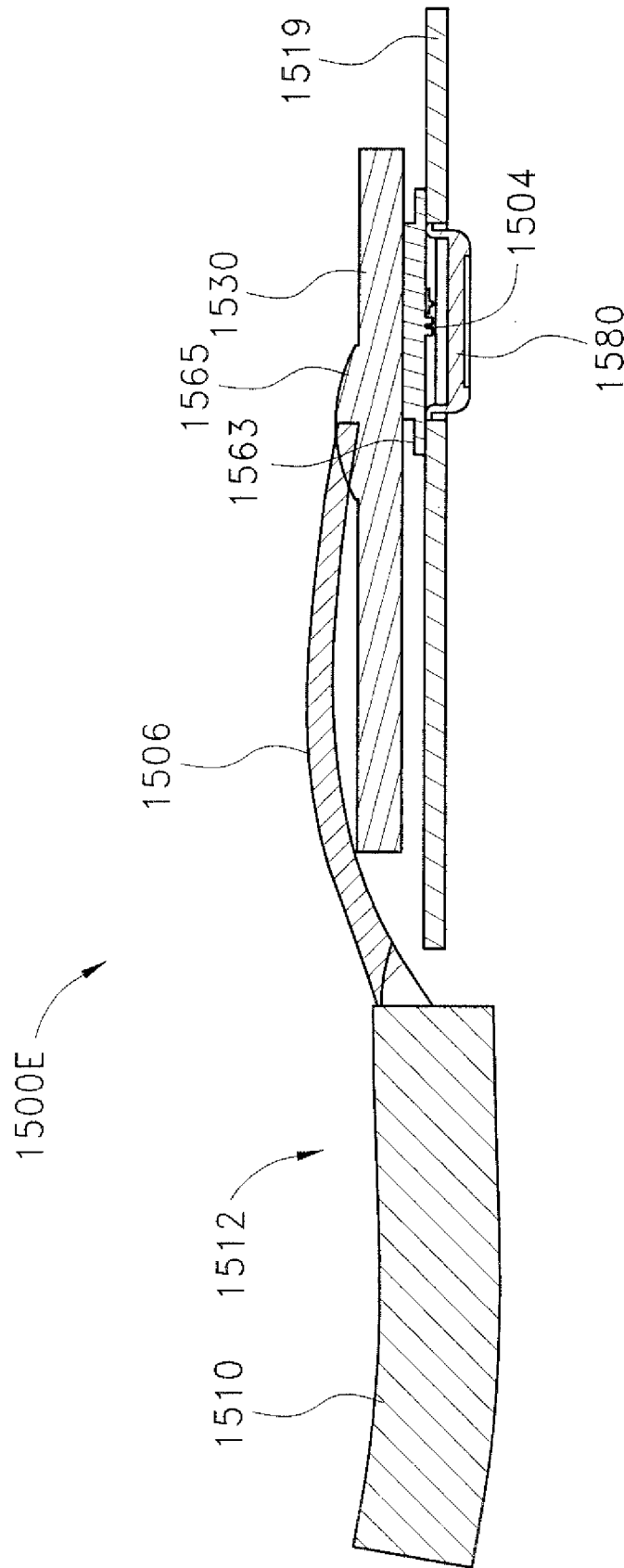


FIG. 15F



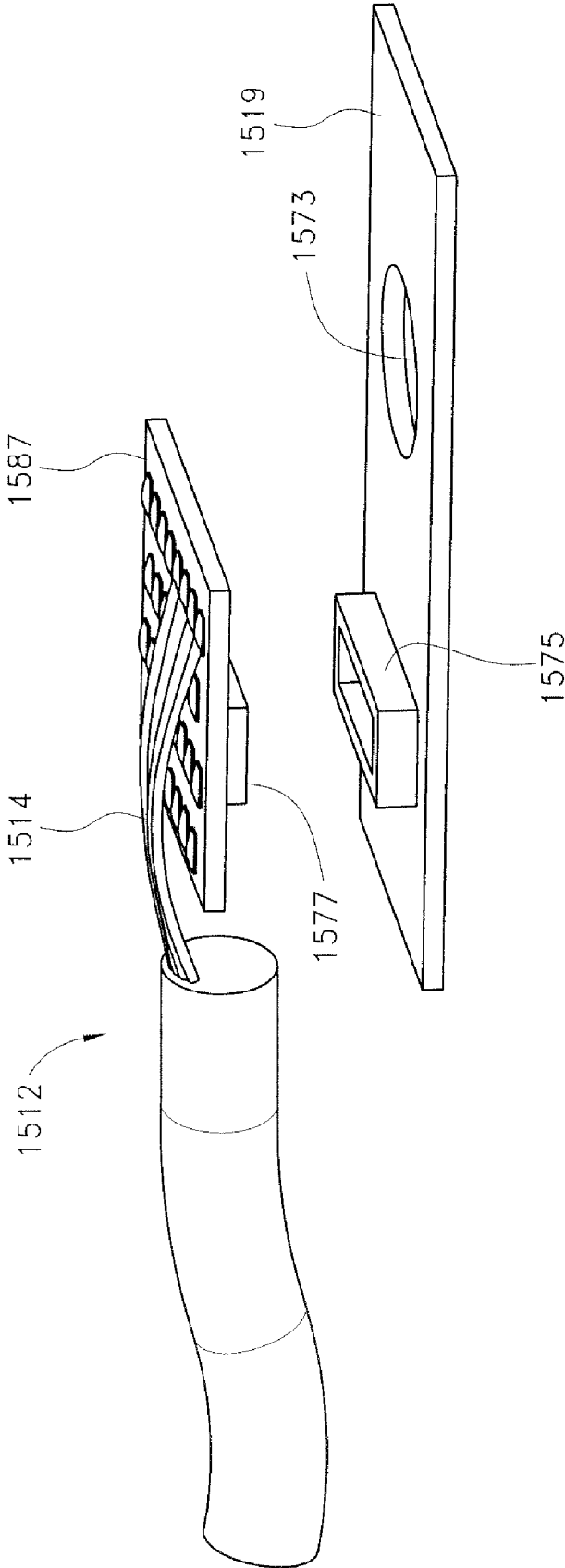


FIG. 15G

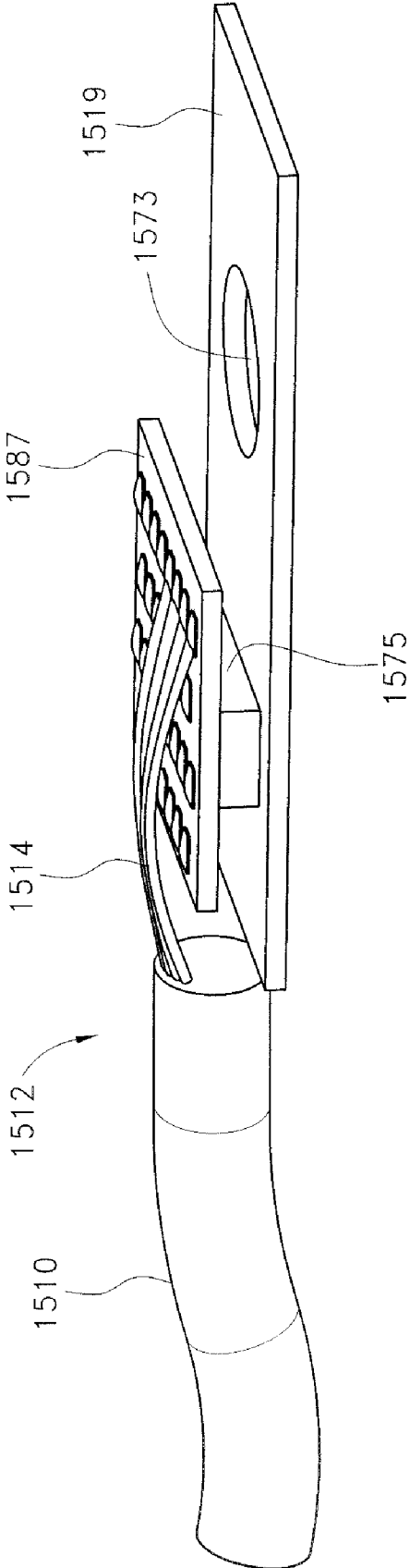


FIG. 15H

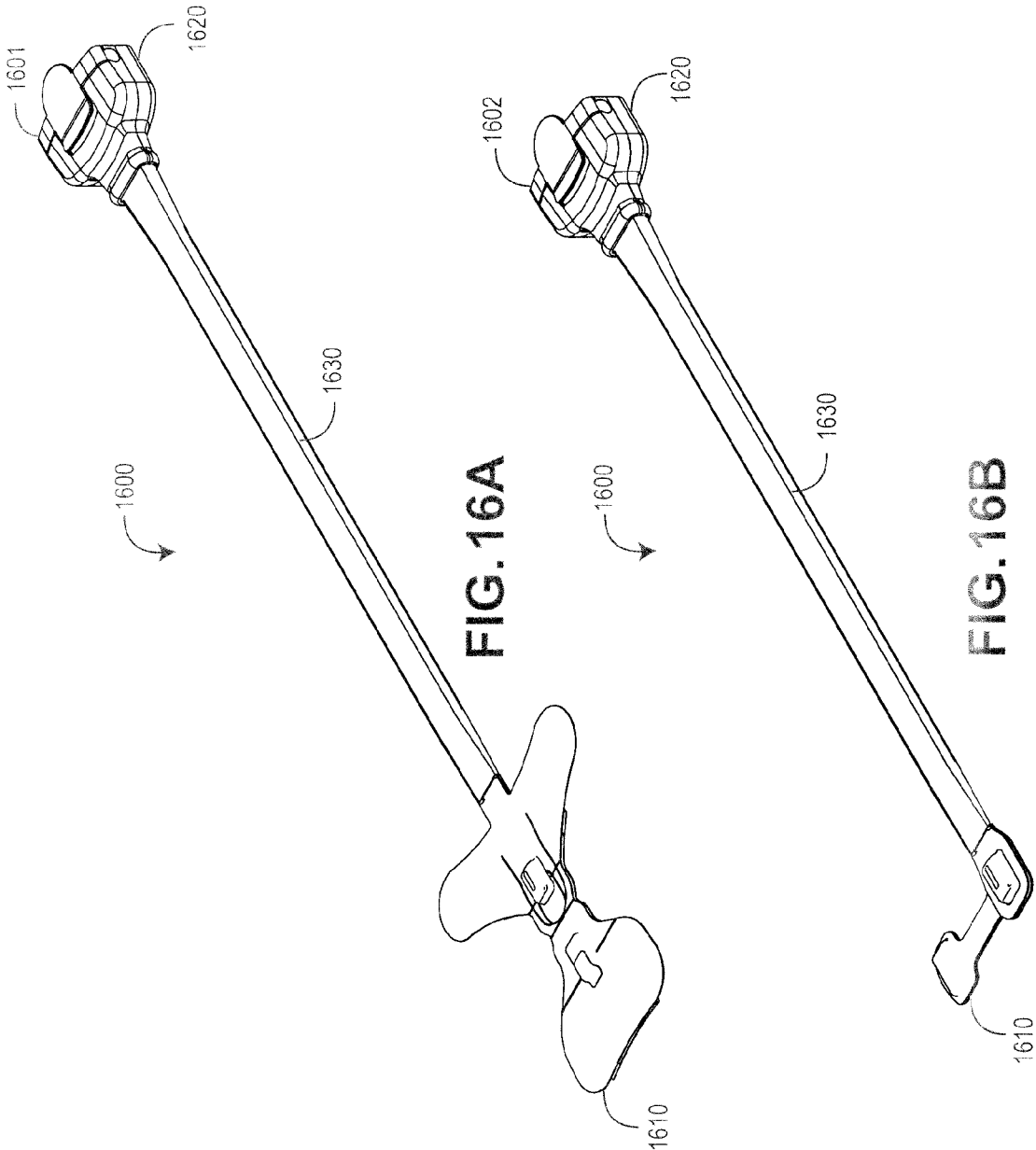


FIG. 16A

FIG. 16B

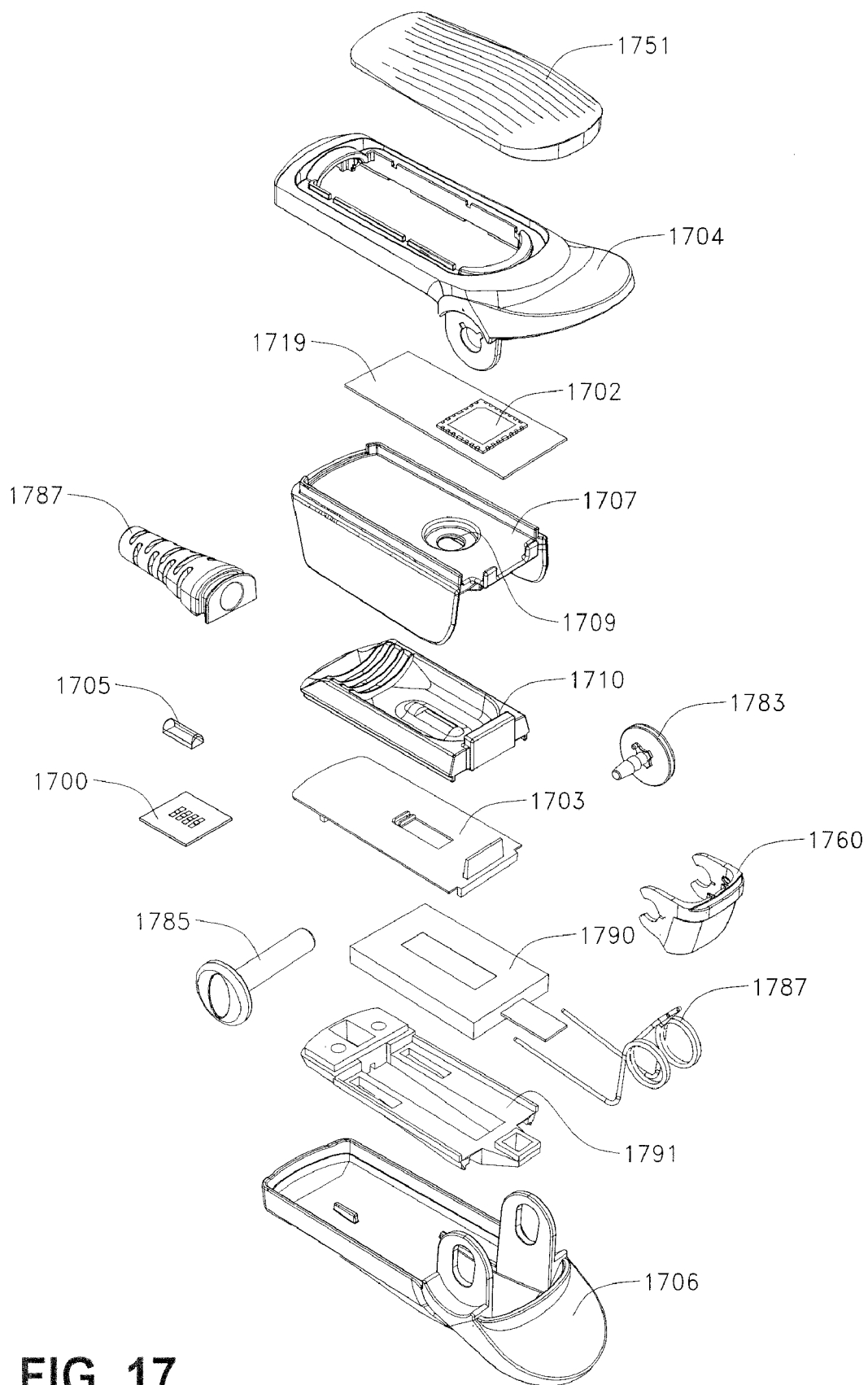


FIG. 17

## HEAT SINK FOR NONINVASIVE MEDICAL SENSOR

### RELATED APPLICATIONS

**[0001]** This application claims the benefit of priority under 35 U.S.C. § 119(e) of the following U.S. Provisional Patent Applications:

App. No.	Filing Date	Title	Attorney Docket
61/086,060	Aug. 4, 2008	Multi-Stream Data Collection System For Non-Invasive Measurement of Glucose and Other Analytes	MLHUM.002PR
61/086,108	Aug. 4, 2008	Multi-Stream Sensor Front Ends for Noninvasive Measurement of Glucose and Other Analytes	MLHUM.003PR
61/086,063	Aug. 4, 2008	Multi-Stream Detector For Noninvasive Measurement Of Glucose And Other Analytes	MLHUM.004PR
61/086,057	Aug. 4, 2008	Multi-Stream Emitter For Noninvasive Measurement Of Glucose And Other Analytes	MLHUM.005PR
61/078,228	Jul. 3, 2008	Noise Shielding For A Non-Invasive Device	MLHUM.006PR
61/078,207	Jul. 3, 2008	Contoured Protrusion for Improving Spectroscopic Measurement of Blood Constituents	MLHUM.007PR
61/091,732	Aug. 25, 2008	Sensor For Improving Measurement Of Blood Constituents	MLHUM.011PR

**[0002]** This application also claims the benefit of priority under 35 U.S.C. § 120 as a continuation-in-part of the following U.S. Design Patent Applications:

App. No.	Filing Date	Title	Attorney Docket
29/323,409	Aug. 25, 2008	Patient Monitoring Sensor	MLHUM.009DA
29/323,408	Aug. 25, 2008	Patient Monitor	MLHUM.010DA

**[0003]** The foregoing applications are hereby incorporated by reference in their entirety.

### BACKGROUND

**[0004]** The standard of care in caregiver environments includes patient monitoring through spectroscopic analysis using, for example, a pulse oximeter. Devices capable of spectroscopic analysis generally include a light source(s) transmitting optical radiation into or reflecting off a measurement site, such as, body tissue carrying pulsing blood. After attenuation by tissue and fluids of the measurement site, a photodetection device(s) detects the attenuated light and outputs a detector signal(s) responsive to the detected attenuated light. A signal processing device(s) process the detector(s) signal(s) and outputs a measurement indicative of a blood constituent of interest, such as glucose, oxygen, met hemoglobin, total hemoglobin, other physiological parameters, or other data or combinations of data useful in determining a state or trend of wellness of a patient.

**[0005]** In noninvasive devices and methods, a sensor is often adapted to position a finger proximate the light source

and light detector. For example, noninvasive sensors often include a clothespin-shaped housing that includes a contoured bed conforming generally to the shape of a finger. The contoured bed positions the finger for measurement and attempts to stabilize it.

**[0006]** Unfortunately, this type of contour cannot be ideal, especially for measuring blood constituents like glucose.

### SUMMARY

**[0007]** This disclosure describes embodiments of noninvasive methods, devices, and systems for measuring a blood analyte, such as oxygen, carbon monoxide, methemoglobin, total hemoglobin, glucose, proteins, glucose, lipids, a percentage thereof (e.g., saturation) or for measuring many other physiologically relevant patient characteristics. These characteristics can relate, for example, to pulse rate, hydration, trending information and analysis, and the like. In certain embodiments, a noninvasive sensor interfaces with tissue at a measurement site and deforms the tissue in a way that increases signal gain in certain desired wavelengths. In an embodiment, a protrusion can be provided in a finger bed of a noninvasive sensor for a patient's finger. The protrusion can reduce tissue thickness, thereby sometimes increasing signal gain by tens of times or even more. This protrusion can include different sizes and shapes depending on the tissue site and the desired blood analyte to be measured.

**[0008]** In disclosed embodiments, the protrusion is employed in noninvasive sensors to assist in measuring and detecting various analytes. The disclosed noninvasive sensor can also include, among other things, emitters and detectors positioned to produce multi-stream sensor information. The noninvasive sensor can have different architectures and can include or be coupled to other components, such as a display device, a network interface, and the like. The protrusion can be employed in any type of noninvasive sensor.

**[0009]** In certain embodiments, a noninvasive physiological sensor for measuring one or more physiological parameters of a medical patient can include a bump interposed between a light source and a photodetector. The bump can be placed in contact with body tissue of a patient and thereby

reduce a thickness of the body tissue. As a result, an optical pathlength between the light source and the photodetector can be reduced. In addition, the sensor can include a heat sink that can direct heat away from the light source. Moreover, the sensor can include shielding in the optical path between the light source and the photodetector. The shielding can reduce noise received by the photodetector.

[0010] For purposes of summarizing the disclosure, certain aspects, advantages and novel features of the inventions have been described herein. It is to be understood that not necessarily all such advantages can be achieved in accordance with any particular embodiment of the inventions disclosed herein. Thus, the inventions disclosed herein can be embodied or carried out in a manner that achieves or optimizes one advantage or group of advantages as taught herein without necessarily achieving other advantages as can be taught or suggested herein.

#### BRIEF DESCRIPTION OF THE DRAWINGS

[0011] Throughout the drawings, reference numbers can be re-used to indicate correspondence between referenced elements. The drawings are provided to illustrate embodiments of the inventions described herein and not to limit the scope thereof.

[0012] FIG. 1 illustrates a block diagram of an example data collection system capable of noninvasively measuring one or more blood analytes in a monitored patient, according to an embodiment of the disclosure;

[0013] FIGS. 2A-2D illustrate an exemplary handheld monitor and an exemplary noninvasive optical sensor of the patient monitoring system of FIG. 1, according to embodiments of the disclosure;

[0014] FIGS. 3A-3C illustrate side and perspective views of an exemplary noninvasive sensor housing including a finger bed protrusion and heat sink, according to an embodiment of the disclosure;

[0015] FIG. 3D illustrates a side view of another example noninvasive sensor housing including a heat sink, according to an embodiment of the disclosure;

[0016] FIG. 3E illustrates a perspective view of an example noninvasive sensor detector shell including example detectors, according to an embodiment of the disclosure;

[0017] FIG. 3F illustrates a side view of an example noninvasive sensor housing including a finger bed protrusion and heat sink, according to an embodiment of the disclosure;

[0018] FIGS. 4A through 4C illustrate top elevation, side and top perspective views of an example protrusion, according to an embodiment of the disclosure;

[0019] FIG. 5 illustrates an example graph depicting possible effects of a protrusion on light transmittance, according to an embodiment of the disclosure;

[0020] FIGS. 6A through 6D illustrate perspective, front elevation, side and top views of another example protrusion, according to an embodiment of the disclosure;

[0021] FIG. 6E illustrates an example sensor incorporating the protrusion of FIGS. 6A through 6D, according to an embodiment of the disclosure;

[0022] FIGS. 7A through 7B illustrate example arrangements of conductive glass that may be employed in the system of FIG. 1, according to embodiments of the disclosure.

[0023] FIGS. 8A through 8D illustrate an example top elevation view, side views, and a bottom elevation view of the conductive glass that may be employed in the system of FIG. 1, according to embodiments of the disclosure;

[0024] FIG. 9 shows example comparative results obtained by an embodiment of a sensor;

[0025] FIGS. 10A and 10B illustrate comparative noise floors of various embodiments of the present disclosure;

[0026] FIG. 11 illustrates a block diagram of some of the components that may include an embodiment of a sensor, according to an embodiment of the disclosure;

[0027] FIG. 12 illustrates an example detector portion that may be employed in an embodiment of a sensor, according to an embodiment of the disclosure;

[0028] FIG. 13 illustrates an example multi-stream operation of the system of FIG. 1, according to an embodiment of the disclosure;

[0029] FIG. 14A illustrates another example detector portion having a partially cylindrical protrusion that can be employed in an embodiment of a sensor, according to an embodiment of the disclosure;

[0030] FIG. 14B depicts a front elevation view of the partially cylindrical protrusion of FIG. 14A;

[0031] FIGS. 14C through 14E illustrate embodiments of a detector submount;

[0032] FIGS. 14F through 14H illustrate embodiment of portions of a detector shell;

[0033] FIG. 14I illustrates a cutaway view of an embodiment of a sensor;

[0034] FIGS. 15A through 15F illustrate embodiments of sensors that include heat sink features;

[0035] FIGS. 15G and 15H illustrate embodiments of connector features that can be used with any of the sensors described herein;

[0036] FIGS. 16A and 16B illustrate embodiments of disposable optical sensors; and

[0037] FIG. 17 illustrates an exploded view of certain components of an example sensor.

#### DETAILED DESCRIPTION

[0038] The present disclosure generally relates to non-invasive medical devices. In an embodiment, a physiological sensor includes a detector housing that can be coupled to a measurement site, such as a patient's finger. The sensor housing can include a curved bed that can generally conform to the shape of the measurement site. In addition, the curved bed can include a protrusion shaped to increase an amount of light radiation from the measurement site. In an embodiment, the protrusion is used to thin out the measurement site. This allows the light radiation to pass through less tissue, and accordingly is attenuated less. In an embodiment, the protrusion can be used to increase the area from which attenuated light can be measured. In an embodiment, this is done through the use of a lens which collects attenuated light exiting the measurement site and focuses onto one or more detectors. The protrusion can advantageously include plastic, including a hard opaque plastic, such as a black or other colored plastic, helpful in reducing light noise. In an embodiment, such light noise includes light that would otherwise be detected at a photodetector that has not been attenuated by tissue of the measurement site of a patient sufficient to cause the light to adequately included information indicative of one or more physiological parameters of the patient. Such light noise includes light piping.

[0039] In an embodiment, the protrusion can be formed from the curved bed, or can be a separate component that is positionable with respect to the bed. In an embodiment, a lens made from any appropriate material is used as the protrusion.

The protrusion can be convex in shape. The protrusion can also be sized and shaped to conform the measurement site into a flat or relatively flat surface. The protrusion can also be sized to conform the measurement site into a rounded surface, such as, for example, a concave or convex surface. The protrusion can include a cylindrical or partially cylindrical shape. The protrusion can be sized or shaped differently for different types of patients, such as an adult, child, or infant. The protrusion can also be sized or shaped differently for different measurement sites, including, for example, a finger, toe, hand, foot, ear, forehead, or the like. The protrusion can thus be helpful in any type of noninvasive sensor. The external surface of the protrusion can include one or more openings or windows. The openings can be made from glass to allow attenuated light from a measurement site, such as a finger, to pass through to one or more detectors. Alternatively, some of all of the protrusion can be a lens, such as a partially cylindrical lens.

**[0040]** The sensor can also include a shielding, such as a metal enclosure as described below or embedded within the protrusion to reduce noise. The shielding can be constructed from a conductive material, such as copper, in the form of a metal cage or enclosure, such as a box. The shielding can include a second set of one or more openings or windows. The second set of openings can be made from glass and allow light that has passed through the first set of windows of the external surface of the protrusion to pass through to one or more detectors that can be enclosed, for example, as described below.

**[0041]** In various embodiments, the shielding can include any substantially transparent, conductive material placed in the optical path between an emitter and a detector. The shielding can be constructed from a transparent material, such as glass, plastic, and the like. The shielding can have an electrically conductive material or coating that is at least partially transparent. The electrically conductive coating can be located on one or both sides of the shielding, or within the body of the shielding. In addition, the electrically conductive coating can be uniformly spread over the shielding or may be patterned. Furthermore, the coating can have a uniform or varying thickness to increase or optimize its shielding effect. The shielding can be helpful in virtually any type of noninvasive sensor that employs spectroscopy.

**[0042]** In an embodiment, the sensor can also include a heat sink. In an embodiment, the heat sink can include a shape that is functional in its ability to dissipate excess heat and aesthetically pleasing to the wearer. For example, the heat sink can be configured in a shape that maximizes surface area to allow for greater dissipation of heat. In an embodiment, the heat sink includes a metallicized plastic, such as plastic including carbon and aluminum to allow for improved thermal conductivity and diffusivity. In an embodiment, the heat sink can advantageously be inexpensively molded into desired shapes and configurations for aesthetic and functional purposes. For example, the shape of the heat sink can be a generally curved surface and include one or more fins, undulations, grooves or channels, or combs.

**[0043]** In the present disclosure, a sensor can measure various blood analytes noninvasively using multi-stream spectroscopy. In an embodiment, the multi-stream spectroscopy can employ visible, infrared and near infrared wavelengths. As disclosed herein, the sensor is capable of noninvasively

measuring blood analytes or percentages thereof (e.g., saturation) based on various combinations of features and components.

**[0044]** The sensor can include photocommunicative components, such as an emitter, a detector, and other components. The emitter can include a plurality of sets of optical sources that, in an embodiment, are arranged together as a point source. The various optical sources can emit a sequence of optical radiation pulses at different wavelengths towards a measurement site, such as a patient's finger. Detectors can then detect optical radiation from the measurement site. The optical sources and optical radiation detectors can operate at any appropriate wavelength, including, as discussed herein, infrared, near infrared, visible light, and ultraviolet. In addition, the optical sources and optical radiation detectors can operate at any appropriate wavelength, and such modifications to the embodiments desirable to operate at any such wavelength will be apparent to those skilled in the art. In certain embodiments, multiple detectors are employed and arranged in a spatial geometry. This spatial geometry provides a diversity of path lengths among at least some of the detectors and allows for multiple bulk and pulsatile measurements that are robust. Each of the detectors can provide a respective output stream based on the detected optical radiation, or a sum of output streams can be provided from multiple detectors. In some embodiments, the sensor can also include other components, such as one or more heat sinks and one or more thermistors.

**[0045]** The sensor can be coupled to one or more monitors that process and/or display the sensor's output. The monitors can include various components, such as a sensor front end, a signal processor, a display, etc.

**[0046]** The sensor can be integrated with a monitor, for example, into a handheld unit including the sensor, a display and user controls. In other embodiments, the sensor can communicate with one or more processing devices. The communication can be via wire(s), cable(s), flex circuit(s), wireless technologies, or other suitable analog or digital communication methodologies and devices to perform those methodologies. Many of the foregoing arrangements allow the sensor to be attached to the measurement site while the device is attached elsewhere on a patient, such as the patient's arm, or placed at a location near the patient, such as a bed, shelf or table. The sensor or monitor can also provide outputs to a storage device or network interface.

**[0047]** Reference will now be made to the Figures to discuss embodiments of the present disclosure.

**[0048]** FIG. 1 illustrates an example of a data collection system **100**. In certain embodiments, the data collection system **100** noninvasively measure a blood analyte, such as oxygen, carbon monoxide, methemoglobin, total hemoglobin, glucose, proteins, glucose, lipids, a percentage thereof (e.g., saturation) or for measuring many other physiologically relevant patient characteristics. The system **100** can also measure additional blood analytes and/or other physiological parameters useful in determining a state or trend of wellness of a patient.

**[0049]** The data collection system **100** can be capable of measuring optical radiation from the measurement site. For example, in some embodiments the data collection system **100** can employ photodiodes defined in terms of area. In an embodiment, the area is from about  $1 \text{ mm}^2$ - $5 \text{ mm}^2$  (or higher) that are capable of detecting about 100 nanoamps (nA) or less of current resulting from measured light at full scale. In

addition to having its ordinary meaning, the phrase “at full scale” can mean light saturation of a photodiode amplifier (not shown). Of course, as would be understood by a person of skill in the art from the present disclosure various other sizes and types of photodiodes can be used with the embodiments of the present disclosure.

**[0050]** The data collection system **100** can measure a range of approximately about 2 nA to about 100 nA full scale. The data collection system **100** can also include sensor front-ends that are capable of processing and amplifying current from the detector(s) at signal-to-noise ratios (SNRs) of about 100 decibels (dB) or more, such as about 120 dB in order to measure various desired analytes. The data collection system **100** can operate with a lower SNR if less accuracy is desired for an analyte like glucose.

**[0051]** The data collection system **100** can measure analyte concentrations, including glucose, at least in part by detecting light attenuated by a measurement site **102**. The measurement site **102** can be any location on a patient's body, such as a finger, foot, ear lobe, or the like. For convenience, this disclosure is described primarily in the context of a finger measurement site **102**. However, the features of the embodiments disclosed herein can be used with other measurement sites **102**.

**[0052]** In the depicted embodiment, the system **100** includes an optional tissue thickness adjuster or tissue shaper **105**, which can include one or more protrusions, bumps, lenses, or other suitable tissue-shaping mechanisms. In certain embodiments, the tissue shaper **105** is a flat or substantially flat surface that can be positioned proximate the measurement site **102** and that can apply sufficient pressure to cause the tissue of the measurement site **102** to be flat or substantially flat. In other embodiments, the tissue shaper **105** is a convex or substantially convex surface with respect to the measurement site **102**. Many other configurations of the tissue shaper **105** are possible. Advantageously, in certain embodiments, the tissue shaper **105** reduces thickness of the measurement site **102** while preventing or reducing occlusion at the measurement site **102**. Reducing thickness of the site can advantageously reduce the amount of attenuation of the light because there is less tissue through which the light must travel. Shaping the tissue in to a convex (or alternatively concave) surface can also provide more surface area from which light can be detected.

**[0053]** The embodiment of the data collection system **100** shown also includes an optional noise shield **103**. In an embodiment, the noise shield **103** can be advantageously adapted to reduce electromagnetic noise while increasing the transmittance of light from the measurement site **102** to one or more detectors **106** (described below). For example, the noise shield **103** can advantageously include a conductive coated glass or metal grid electrically communicating with one or more other shields of the sensor **101**. In an embodiment where the noise shield **103** includes conductive coated glass, the coating can advantageously include indium tin oxide. In an embodiment, the indium tin oxide includes a surface resistivity ranging from approximately from 30 ohms per square inch to 500 ohms per square inch. In an embodiment, the resistivity is approximately 30, 200, or 500 ohms per square inch. As would be understood by a person of skill in the art from the present disclosure, other resistivities can also be used which are less than 30 ohms or more than 500 ohms. Other conductive materials transparent or substantially transparent to light can be used instead.

**[0054]** In some embodiments, the measurement site **102** is somewhere along a non-dominant arm or a non-dominant hand, e.g., a right-handed person's left arm or left hand. In some patients, the non-dominant arm or hand can have less musculature and higher fat content, which can result in less water content in that tissue of the patient. Tissue having less water content can provide less interference with the particular wavelengths that are absorbed in a useful manner by blood analytes like glucose. Accordingly, in some embodiments, the data collection system **100** can be used on a person's non-dominant hand or arm.

**[0055]** The data collection system **100** can include a sensor **101** (or multiple sensors) that is coupled to a processing device or physiological monitor **109**. In an embodiment, the sensor **101** and the monitor **109** are integrated together into a single unit. In another embodiment, the sensor **101** and the monitor **109** are separate from each other and communicate one with another in any suitable manner, such as via a wired or wireless connection. The sensor **101** and monitor **109** can be attachable and detachable from each other for the convenience of the user or caregiver, for ease of storage, sterility issues, or the like. The sensor **101** and the monitor **109** will now be further described.

**[0056]** In the depicted embodiment shown in FIG. 1, the sensor **101** includes an emitter **104**, a tissue shaper **105**, a set of detectors **106**, and a front-end interface **108**. The emitter **104** can serve as the source of optical radiation transmitted towards measurement site **102**. As will be described in further detail below, the emitter **104** can include one or more sources of optical radiation, such as LEDs, laser diodes, incandescent bulbs with appropriate frequency-selective filters, combinations of the same, or the like. In an embodiment, the emitter **104** includes sets of optical sources that are capable of emitting visible and near-infrared optical radiation.

**[0057]** In some embodiments, the emitter **104** is used as a point optical source, and thus, the one or more optical sources of the emitter **104** can be located within a close distance to each other, such as within about a 2 mm to about 4 mm. The emitters **104** can be arranged in an array, such as is described in U.S. Publication No. 2006/0211924, filed Sep. 21, 2006, titled “Multiple Wavelength Sensor Emitters,” the disclosure of which is hereby incorporated by reference in its entirety. In particular, the emitters **104** can be arranged at least in part as described in paragraphs [0061] through [0068] of the aforementioned publication, which paragraphs are hereby incorporated specifically by reference. Other relative spatial relationships can be used to arrange the emitters **104**.

**[0058]** For analytes like glucose, currently available non-invasive techniques often attempt to employ light near the water absorbance minima at or about 1600 nm. Typically, these devices and methods employ a single wavelength or single band of wavelengths at or about 1600 nm. However, to date, these techniques have been unable to adequately consistently measure analytes like glucose based on spectroscopy.

**[0059]** In contrast, the emitter **104** of the data collection system **100** can emit, in certain embodiments, combinations of optical radiation in various bands of interest. For example, in some embodiments, for analytes like glucose, the emitter **104** can emit optical radiation at three (3) or more wavelengths between about 1600 nm to about 1700 nm. In particular, the emitter **104** can emit optical radiation at or about 1610 nm, about 1640 nm, and about 1665 nm. In some circumstances, the use of three wavelengths within about 1600 nm to



about 1700 nm enable sufficient SNRs of about 100 dB, which can result in a measurement accuracy of about 20 mg/DL or better for analytes like glucose.

[0060] In other embodiments, the emitter 104 can use two (2) wavelengths within about 1600 nm to about 1700 nm to advantageously enable SNRs of about 85 dB, which can result in a measurement accuracy of about 25-30 mg/DL or better for analytes like glucose. Furthermore, in some embodiments, the emitter 104 can emit light at wavelengths above about 1670 nm. Measurements at these wavelengths can be advantageously used to compensate or confirm the contribution of protein, water, and other non-hemoglobin species exhibited in measurements for analytes like glucose conducted between about 1600 nm and about 1700 nm. Of course, other wavelengths and combinations of wavelengths can be used to measure analytes and/or to distinguish other types of tissue, fluids, tissue properties, fluid properties, combinations of the same or the like.

[0061] For example, the emitter 104 can emit optical radiation across other spectra for other analytes. In particular, the emitter 104 can employ light wavelengths to measure various blood analytes or percentages (e.g., saturation) thereof. For example, in one embodiment, the emitter 104 can emit optical radiation in the form of pulses at wavelengths about 905 nm, about 1050 nm, about 1200 nm, about 1300 nm, about 1330 nm, about 1610 nm, about 1640 nm, and about 1665 nm. In another embodiment, the emitter 104 can emit optical radiation ranging from about 860 nm to about 950 nm, about 950 nm to about 1100 nm, about 1100 nm to about 1270 nm, about 1250 nm to about 1350 nm, about 1300 nm to about 1360 nm, and about 1590 nm to about 1700 nm. Of course, the emitter 104 can transmit any of a variety of wavelengths of visible or near-infrared optical radiation.

[0062] Due to the different responses of analytes to the different wavelengths, certain embodiments of the data collection system 100 can advantageously use the measurements at these different wavelengths to improve the accuracy of measurements. For example, the measurements of water from visible and infrared light can be used to compensate for water absorbance that is exhibited in the near-infrared wavelengths.

[0063] As briefly described above, the emitter 104 can include sets of light-emitting diodes (LEDs) as its optical source. The emitter 104 can use one or more top-emitting LEDs. In particular, in some embodiments, the emitter 104 can include top-emitting LEDs emitting light at about 850 nm to 1350 nm.

[0064] The emitter 104 can also use super luminescent LEDs (SLEDs) or side-emitting LEDs. In some embodiments, the emitter 104 can employ SLEDs or side-emitting LEDs to emit optical radiation at about 1600 nm to about 1800 nm. Emitter 104 can use SLEDs or side-emitting LEDs to transmit near infrared optical radiation because these types of sources can transmit at high power or relatively high power, e.g., about 40 mW to about 100 mW. This higher power capability can be useful to compensate or overcome the greater attenuation of these wavelengths of light in tissue and water. For example, the higher power emission can effectively compensate and/or normalize the absorption signal for light in the mentioned wavelengths to be similar in amplitude and/or effect as other wavelengths that can be detected by one or more photodetectors after absorption. Alternatively, the emitter 104 can use other types of sources of optical radiation, such as a laser diode, to emit near-infrared light into the measurement site 102.

[0065] In addition, in some embodiments, in order to assist in achieving a comparative balance of desired power output between the LEDs, some of the LEDs in the emitter 104 can have a filter or covering that reduces and/or cleans the optical radiation from particular LEDs or groups of LEDs. For example, since some wavelengths of light can penetrate through tissue relatively well, LEDs, such as some or all of the top-emitting LEDs can use a filter or covering, such as a cap or painted dye. This can be useful in allowing the emitter 104 to use LEDs with a higher output and/or to equalize intensity of LEDs.

[0066] The data collection system 100 also includes a driver 111 that drives the emitter 104. The driver 111 can be a circuit or the like that is controlled by the monitor 109. For example, the driver 111 can provide pulses of current to the emitter 104. In an embodiment, the driver 111 drives the emitter 104 in a progressive fashion, such as in an alternating manner. The driver 111 can drive the emitter 104 with a series of pulses of about 1 milliwatt (mW) for some wavelengths that can penetrate tissue relatively well and from about 40 mW to about 100 mW for other wavelengths that tend to be significantly absorbed in tissue. A wide variety of other driving powers and driving methodologies can be used in various embodiments.

[0067] The driver 111 can be synchronized with other parts of the sensor 101 and can minimize or reduce jitter in the timing of pulses of optical radiation emitted from the emitter 104. In some embodiments, the driver 111 is capable of driving the emitter 104 to emit optical radiation in a pattern that varies by less than about 10 parts-per-million.

[0068] The detectors 106 capture and measure light from the measurement site 102. For example, the detectors 106 can capture and measure light transmitted from the emitter 104 that has been attenuated or reflected from the tissue in the measurement site 102. The detectors 106 can output a detector signal 107 responsive to the light captured or measured. The detectors 106 can be implemented using one or more photodiodes, phototransistors, or the like.

[0069] In addition, the detectors 106 can be arranged with a spatial configuration to provide a variation of path lengths among at least some of the detectors 106. That is, some of the detectors 106 can have the substantially, or from the perspective of the processing algorithm, effectively, the same path length from the emitter 104. However, according to an embodiment, at least some of the detectors 106 can have a different path length from the emitter 104 relative to other of the detectors 106. Variations in path lengths can be helpful in allowing the use of a bulk signal stream from the detectors 106.

[0070] The front end interface 108 provides an interface that adapts the output of the detectors 106, which is responsive to desired physiological parameters. For example, the front end interface 108 can adapt a signal 107 received from one or more of the detectors 106 into a form that can be processed by the monitor 109, for example, by a signal processor 110 in the monitor 109. The front end interface 108 can have its components assembled in the sensor 101, in the monitor 109, in connecting cabling (if used), combinations of the same, or the like. The location of the front end interface 108 can be chosen based on various factors including space desired for components, desired noise reductions or limits, desired heat reductions or limits, and the like.

[0071] The front end interface 108 can be coupled to the detectors 106 and to the signal processor 110 using a bus,

wire, electrical or optical cable, flex circuit, or some other form of signal connection. The front end interface 108 can also be at least partially integrated with various components, such as the detectors 106. For example, the front end interface 108 can include one or more integrated circuits that are on the same circuit board as the detectors 106. Other configurations can also be used.

[0072] The front end interface 108 can be implemented using one or more amplifiers, such as transimpedance amplifiers, that are coupled to one or more analog to digital converters (ADCs) (which can be in the monitor 109), such as a sigma-delta ADC. A transimpedance-based front end interface 108 can employ single-ended circuitry, differential circuitry, and/or a hybrid configuration. A transimpedance-based front end interface 108 can be useful for its sampling rate capability and freedom in modulation/demodulation algorithms. For example, this type of front end interface 108 can advantageously facilitate the sampling of the ADCs being synchronized with the pulses emitted from the emitter 104.

[0073] The ADC or ADCs can provide one or more outputs into multiple channels of digital information for processing by the signal processor 110 of the monitor 109. Each channel can correspond to a signal output from a detector 106.

[0074] In some embodiments, a programmable gain amplifier (PGA) can be used in combination with a transimpedance-based front end interface 108. For example, the output of a transimpedance-based front end interface 108 can be output to a PGA that is coupled with an ADC in the monitor 109. A PGA can be useful in order to provide another level of amplification and control of the stream of signals from the detectors 106. Alternatively, the PGA and ADC components can be integrated with the transimpedance-based front end interface 108 in the sensor 101.

[0075] In another embodiment, the front end interface 108 can be implemented using switched-capacitor circuits. A switched-capacitor-based front end interface 108 can be useful for, in certain embodiments, its resistor-free design and analog averaging properties. In addition, a switched-capacitor-based front end interface 108 can be useful because it can provide a digital signal to the signal processor 110 in the monitor 109.

[0076] As shown in FIG. 1, the monitor 109 can include the signal processor 110 and a user interface, such as a display 112. The monitor 109 can also include optional outputs alone or in combination with the display 112, such as a storage device 114 and a network interface 116. In an embodiment, the signal processor 110 includes processing logic that determines measurements for desired analytes, such as glucose, based on the signals received from the detectors 106. The signal processor 110 can be implemented using one or more microprocessors or subprocessors (e.g., cores), digital signal processors, application specific integrated circuits (ASICs), field programmable gate arrays (FPGAs), combinations of the same, and the like.

[0077] The signal processor 110 can provide various signals that control the operation of the sensor 101. For example, the signal processor 110 can provide an emitter control signal to the driver 111. This control signal can be useful in order to synchronize, minimize, or reduce jitter in the timing of pulses emitted from the emitter 104. Accordingly, this control signal can be useful in order to cause optical radiation pulses emitted from the emitter 104 to follow a precise timing and consistent pattern. For example, when a transimpedance-based front end interface 108 is used, the control signal from the signal processor

110 can provide synchronization with the ADC in order to avoid aliasing, cross-talk, and the like. As also shown, an optional memory 113 can be included in the front-end interface 108 and/or in the signal processor 110. This memory 113 can serve as a buffer or storage location for the front-end interface 108 and/or the signal processor 110, among other uses.

[0078] The user interface 112 can provide an output, e.g., on a display, for presentation to a user of the data collection system 100. The user interface 112 can be implemented as a touch-screen display, an LCD display, an organic LED display, or the like. In addition, the user interface 112 can be manipulated to allow for measurement on the non-dominant side of patient. For example, the user interface 112 can include a flip screen, a screen that can be moved from one side to another on the monitor 109, or can include an ability to reorient its display indicia responsive to user input or device orientation. In alternative embodiments, the data collection system 100 can be provided without a user interface 112 and can simply provide an output signal to a separate display or system.

[0079] A storage device 114 and a network interface 116 represent other optional output connections that can be included in the monitor 109. The storage device 114 can include any computer-readable medium, such as a memory device, hard disk storage, EEPROM, flash drive, or the like. The various software and/or firmware applications can be stored in the storage device 114, which can be executed by the signal processor 110 or another processor of the monitor 109. The network interface 116 can be a serial bus port (RS-232/RS-485), a Universal Serial Bus (USB) port, an Ethernet port, a wireless interface (e.g., WiFi such as any 802.1x interface, including an internal wireless card), or other suitable communication device(s) that allows the monitor 109 to communicate and share data with other devices. The monitor 109 can also include various other components not shown, such as a microprocessor, graphics processor, or controller to output the user interface 112, to control data communications, to compute data trending, or to perform other operations.

[0080] Although not shown in the depicted embodiment, the data collection system 100 can include various other components or can be configured in different ways. For example, the sensor 101 can have both the emitter 104 and detectors 106 on the same side of the measurement site 102 and use reflectance to measure analytes. The data collection system 100 can also include a sensor that measures the power of light emitted from the emitter 104.

[0081] FIGS. 2A through 2D illustrate example monitoring devices 200 in which the data collection system 100 can be housed. Advantageously, in certain embodiments, some or all of the example monitoring devices 200 shown can have a shape and size that allows a user to operate it with a single hand or attach it, for example, to a patient's body or limb. Although several examples are shown, many other monitoring device configurations can be used to house the data collection system 100. In addition, certain of the features of the monitoring devices 200 shown in FIGS. 2A through 2D can be combined with features of the other monitoring devices 200 shown.

[0082] Referring specifically to FIG. 2A, an example monitoring device 200A is shown, in which a sensor 201a and a monitor 209a are integrated into a single unit. The monitoring device 200A shown is a handheld or portable device that can measure glucose and other analytes in a patient's finger. The

sensor **201a** includes an emitter shell **204a** and a detector shell **206a**. The depicted embodiment of the monitoring device **200A** also includes various control buttons **208a** and a display **210a**.

[0083] The sensor **201a** can be constructed of white material used for reflective purposes (such as white silicone or plastic), which can increase usable signal at the detector **106** by forcing light back into the sensor **201a**. Pads in the emitter shell **204a** and the detector shell **206a** can contain separated windows to prevent or reduce mixing of light signals, for example, from distinct quadrants on a patient's finger. In addition, these pads can be made of a relatively soft material, such as a gel or foam, in order to conform to the shape, for example, of a patient's finger. The emitter shell **204a** and the detector shell **206a** can also include absorbing black or grey material portions to prevent or reduce ambient light from entering into the sensor **201a**.

[0084] In some embodiments, some or all portions of the emitter shell **204a** and/or detector shell **206a** can be detachable and/or disposable. For example, some or all portions of the shells **204a** and **206a** can be removable pieces. The removability of the shells **204a** and **206a** can be useful for sanitary purposes or for sizing the sensor **201a** to different patients. The monitor **209a** can include a fitting, slot, magnet, or other connecting mechanism to allow the sensor **201c** to be removably attached to the monitor **209a**.

[0085] The monitoring device **200a** also includes optional control buttons **208a** and a display **210a** that can allow the user to control the operation of the device. For example, a user can operate the control buttons **208a** to view one or more measurements of various analytes, such as glucose. In addition, the user can operate the control buttons **208a** to view other forms of information, such as graphs, histograms, measurement data, trend measurement data, parameter combination views, wellness indications, and the like. Many parameters, trends, alarms and parameter displays could be output to the display **210a**, such as those that are commercially available through a wide variety of noninvasive monitoring devices from Masimo® Corporation of Irvine, Calif.

[0086] Furthermore, the controls **208a** and/or display **210a** can provide functionality for the user to manipulate settings of the monitoring device **200a**, such as alarm settings, emitter settings, detector settings, and the like. The monitoring device **200a** can employ any of a variety of user interface designs, such as frames menus, touch-screens, and any type of button.

[0087] FIG. 2B illustrates another example of a monitoring device **200B**. In the depicted embodiment, the monitoring device **200B** includes a finger clip sensor **201b** connected to a monitor **209b** via a cable **212**. In the embodiment shown, the monitor **209b** includes a display **210b**, control buttons **208b** and a power button. Moreover, the monitor **209b** can advantageously include electronic processing, signal processing, and data storage devices capable of receiving signal data from said sensor **201b**, processing the signal data to determine one or more output measurement values indicative of one or more physiological parameters of a monitored patient, and displaying the measurement values, trends of the measurement values, combinations of measurement values, and the like.

[0088] The cable **212** connecting the sensor **201b** and the monitor **209b** can be implemented using one or more wires, optical fiber, flex circuits, or the like. In some embodiments, the cable **212** can employ twisted pairs of conductors in order to minimize or reduce cross-talk of data transmitted from the sensor **201b** to the monitor **209b**. Various lengths of the cable

**212** can be employed to allow for separation between the sensor **201b** and the monitor **209b**. The cable **212** can be fitted with a connector (male or female) on either end of the cable **212** so that the sensor **201b** and the monitor **209b** can be connected and disconnected from each other. Alternatively, the sensor **201b** and the monitor **209b** can be coupled together via a wireless communication link, such as an infrared link, radio frequency channel, or any other wireless communication protocol and channel.

[0089] The monitor **209b** can be attached to the patient. For example, the monitor **209b** can include a belt clip or straps (see, e.g., FIG. 2C) that facilitate attachment to a patient's belt, arm, leg, or the like. The monitor **209b** can also include a fitting, slot, magnet, LEMO snap-click connector, or other connecting mechanism to allow the cable **212** and sensor **201b** to be attached to the monitor **209b**.

[0090] The monitor **209b** can also include other components, such as a speaker, power button, removable storage or memory (e.g., a flash card slot), an AC power port, and one or more network interfaces, such as a universal serial bus interface or an Ethernet port. For example, the monitor **209b** can include a display **210b** that can indicate a measurement for glucose, for example, in mg/dL. Other analytes and forms of display can also appear on the monitor **209b**.

[0091] In addition, although a single sensor **201b** with a single monitor **209b** is shown, different combinations of sensors and device pairings can be implemented. For example, multiple sensors can be provided for a plurality of differing patient types or measurement sites or even patient fingers.

[0092] FIG. 2C illustrates yet another example of monitoring device **200C** that can house the data collection system **100**. Like the monitoring device **200B**, the monitoring device **200C** includes a finger clip sensor **201c** connected to a monitor **209c** via a cable **212**. The cable **212** can have all of the features described above with respect to FIG. 2B. The monitor **209c** can include all of the features of the monitor **200B** described above. For example, the monitor **209c** includes buttons **208c** and a display **210c**. The monitor **209c** shown also includes straps **214c** that allow the monitor **209c** to be attached to a patient's limb or the like.

[0093] FIG. 2D illustrates yet another example of monitoring device **200D** that can house the data collection system **100**. Like the monitoring devices **200B** and **200C**, the monitoring device **200D** includes a finger clip sensor **201d** connected to a monitor **209d** via a cable **212**. The cable **212** can have all of the features described above with respect to FIG. 2B. In addition to having some or all of the features described above with respect to FIGS. 2B and 2C, the monitoring device **200D** includes an optional universal serial bus (USB) port **216** and an Ethernet port **218**. The USB port **216** and the Ethernet port **218** can be used, for example, to transfer information between the monitor **209d** and a computer (not shown) via a cable. Software stored on the computer can provide functionality for a user to, for example, view physiological data and trends, adjust settings and download firmware updates to the monitor **209b**, and perform a variety of other functions. The USB port **216** and the Ethernet port **218** can be included with the other monitoring devices **200A**, **200B**, and **200C** described above.

[0094] FIGS. 3A through 3C illustrate more detailed examples of embodiments of a sensor **301a**. The sensor **301a** shown can include all of the features of the sensors **100** and **200** described above.

[0095] Referring to FIG. 3A, the sensor 301a in the depicted embodiment is a clothespin-shaped clip sensor that includes an enclosure 302a for receiving a patient's finger. The enclosure 302a is formed by an upper section or emitter shell 304a, which is pivotably connected with a lower section or detector shell 306a. The emitter shell 304a can be biased with the detector shell 306a to close together around a pivot point 303a and thereby sandwich finger tissue between the emitter and detector shells 304a, 306a.

[0096] In an embodiment, the pivot point 303a advantageously includes a pivot capable of adjusting the relationship between the emitter and detector shells 304a, 306a to effectively level the sections when applied to a tissue site. In another embodiment, the sensor 301a includes some or all features of the finger clip described in U.S. Publication No. 2006/0211924, incorporated above, such as a spring that causes finger clip forces to be distributed along the finger. Paragraphs through [0105], which describe this feature, are hereby specifically incorporated by reference.

[0097] The emitter shell 304a can position and house various emitter components of the sensor 301a. It can be constructed of reflective material (e.g., white silicone or plastic) and/or can be metallic or include metallicized plastic (e.g., including carbon and aluminum) to possibly serve as a heat sink. The emitter shell 304a can also include absorbing opaque material, such as, for example, black or grey colored material, at various areas, such as on one or more flaps 307a, to reduce ambient light entering the sensor 301a.

[0098] The detector shell 306a can position and house one or more detector portions of the sensor 301a. The detector shell 306a can be constructed of reflective material, such as white silicone or plastic. As noted, such materials can increase the usable signal at a detector by forcing light back into the tissue and measurement site (see FIG. 1). The detector shell 306a can also include absorbing opaque material at various areas, such as lower area 308a, to reduce ambient light entering the sensor 301a.

[0099] Referring to FIGS. 3B and 3C, an example of finger bed 310 is shown in the sensor 301b. The finger bed 310 includes a generally curved surface shaped generally to receive tissue, such as a human digit. The finger bed 310 includes one or more ridges or channels 314. Each of the ridges 314 has a generally convex shape that can facilitate increasing traction or gripping of the patient's finger to the finger bed. Advantageously, the ridges 314 can improve the accuracy of spectroscopic analysis in certain embodiments by reducing noise that can result from a measurement site moving or shaking loose inside of the sensor 301a. The ridges 314 can be made from reflective or opaque materials in some embodiments to further increase SNR. In other implementations, other surface shapes can be used, such as, for example, generally flat, concave, or convex finger beds 310.

[0100] Finger bed 310 can also include an embodiment of a tissue thickness adjuster or protrusion 305. The protrusion 305 includes a measurement site contact area 370 (see FIG. 3C) that can contact body tissue of a measurement site. The protrusion 305 can be removed from or integrated with the finger bed 310. Interchangeable, different shaped protrusions 305 can also be provided, which can correspond to different finger shapes, characteristics, opacity, sizes, or the like.

[0101] Referring specifically to FIG. 3C, the contact area 370 of the protrusion 305 can include openings or windows 320, 321, 322, and 323. When light from a measurement site passes through the windows 320, 321, 322, and 323, the light

can reach one or more photodetectors (see FIG. 3E). In an embodiment, the windows 320, 321, 322, and 323 mirror specific detector placements layouts such that light can impinge through the protrusion 305 onto the photodetectors. Any number of windows 320, 321, 322, and 323 can be employed in the protrusion 305 to allow light to pass from the measurement site to the photodetectors.

[0102] The windows 320, 321, 322, and 323 can also include shielding, such as an embedded grid of wiring or a conductive glass coating, to reduce noise from ambient light or other electromagnetic noise. The windows 320, 321, 322, and 323 can be made from materials, such as plastic or glass. In some embodiments, the windows 320, 321, 322, and 323 can be constructed from conductive glass, such as indium tin oxide (ITO) coated glass. Conductive glass can be useful because its shielding is transparent, and thus allows for a larger aperture versus a window with an embedded grid of wiring. In addition, in certain embodiments, the conductive glass does not need openings in its shielding (since it is transparent), which enhances its shielding performance. For example, some embodiments that employ the conductive glass can attain up to an about 40% to about 50% greater signal than non-conductive glass with a shielding grid. In addition, in some embodiments, conductive glass can be useful for shielding noise from a greater variety of directions than non-conductive glass with a shielding grid.

[0103] Turning to FIG. 3B, the sensor 301a can also include a shielding 315a, such as a metal cage, box, metal sheet, perforated metal sheet, a metal layer on a non-metal material, or the like. The shielding 315a is provided in the depicted embodiment below or embedded within the protrusion 305 to reduce noise. The shielding 315a can be constructed from a conductive material, such as copper. The shielding 315a can include one or more openings or windows (not shown). The windows can be made from glass or plastic to thereby allow light that has passed through the windows 320, 321, 322, and 323 on an external surface of the protrusion 305 (see FIG. 3C) to pass through to one or more photodetectors that can be enclosed or provided below (see FIG. 3E).

[0104] In an embodiment, the photodetectors can be positioned within or directly beneath the protrusion 305 (see FIG. 3E). In such cases, the mean optical path length from the emitters to the detectors can be reduced and the accuracy of blood analyte measurement can increase. For example, in one embodiment, a convex bump of about 1 mm to about 3 mm in height and about 10 mm<sup>2</sup> to about 60 mm<sup>2</sup> was found to help signal strength by about an order of magnitude versus other shapes. Of course other dimensions and sizes can be employed in other embodiments. Depending on the properties desired, the length, width, and height of the protrusion 305 can be selected. In making such determinations, consideration can be made of protrusion's 305 effect on blood flow at the measurement site and mean path length for optical radiation passing through openings 320, 321, 322, and 323. Patient comfort can also be considered in determining the size and shape of the protrusion.

[0105] In an embodiment, the protrusion 305 can include a pliant material, including soft plastic or rubber, which can somewhat conform to the shape of a measurement site. Pliant materials can improve patient comfort and tactility by conforming the measurement site contact area 370 to the measurement site. Additionally, pliant materials can minimize or

reduce noise, such as ambient light. Alternatively, the protrusion 305 can be made from a rigid material, such as hard plastic or metal.

[0106] Rigid materials can improve measurement accuracy of a blood analyte by conforming the measurement site to the contact area 370. The contact area 370 can be an ideal shape for improving accuracy or reducing noise. Selecting a material for the protrusion 305 can include consideration of materials that do not significantly alter blood flow at the measurement site. The protrusion 305 and the contact area 370 can include a combination of materials with various characteristics.

[0107] The contact area 370 serves as a contact surface for the measurement site. For example, in some embodiments, the contact area 370 can be shaped for contact with a patient's finger. Accordingly, the contact area 370 can be sized and shaped for different sizes of fingers. The contact area 370 can be constructed of different materials for reflective purposes as well as for the comfort of the patient. For example, the contact area 370 can be constructed from materials having various hardness and textures, such as plastic, gel, foam, and the like.

[0108] The formulas and analysis that follow with respect to FIG. 5 provide insight into how selecting these variables can alter transmittance and intensity gain of optical radiation that has been applied to the measurement site. These examples do not limit the scope of this disclosure.

[0109] Referring to FIG. 5, a plot 500 is shown that illustrates examples of effects of embodiments of the protrusion 305 on the SNR at various wavelengths of light. As described above, the protrusion 305 can assist in conforming the tissue and effectively reduce its mean path length. In some instances, this effect by the protrusion 305 can have significant impact on increasing the SNR.

[0110] According to the Beer Lambert law, a transmittance of light (I) can be expressed as follows:  $I = I_o * e^{-m * b * c}$ , where  $I_o$  is the initial power of light being transmitted,  $m$  is the path length traveled by the light, and the component "b\*c" corresponds to the bulk absorption of the light at a specific wavelength of light. For light at about 1600 nm to about 1700 nm, for example, the bulk absorption component is generally around  $0.7 \text{ mm}^{-1}$ . Assuming a typical finger thickness of about 12 mm and a mean path length of 20 mm due to tissue scattering, then  $I = I_o * e^{(-20 * 0.7)}$ .

[0111] In an embodiment where the protrusion 305 is a convex bump, the thickness of the finger can be reduced to 10 mm (from 12 mm) for some fingers and the effective light mean path is reduced to about 16.6 mm from 20 mm (see box 510). This results in a new transmittance,  $I_1 = I_o * e^{(-16.6 * 0.7)}$ . A curve for a typical finger (having a mean path length of 20 mm) across various wavelengths is shown in the plot 500 of FIG. 5. The plot 500 illustrates potential effects of the protrusion 305 on the transmittance. As illustrated, comparing I and  $I_1$  results in an intensity gain of  $e^{(-16.6 * 0.7) / e^{(-20 * 0.7)}}$ , which is about a 10 times increase for light in the about 1600 nm to about 1700 nm range. Such an increase can affect the SNR at which the sensor can operate. The foregoing gains can be due at least in part to the about 1600 nm to about 1700 nm range having high values in bulk absorptions (water, protein, and the like), e.g., about  $0.7 \text{ mm}^{-1}$ . The plot 500 also shows improvements in the visible/near-infrared range (about 600 nm to about 1300 nm).

[0112] The contribution of a the protrusion 305 to increased SNR cannot have been previously recognized by persons having ordinary skill in the art at least in part because cur-

rently available devices can have been concerned primarily with conforming to the measurement site for patient comfort. In addition, for light in the visible range and infrared range, or in other words, at the wavelengths of many previous devices, the bulk absorption of light component in the finger is generally much lower at around  $0.1 \text{ mm}^{-1}$ . Therefore, the same change in thickness increases intensity by, for example,  $e^{(-16.6 * 0.1) / e^{(-20 * 0.1)}}$ , which results in about a 1.5 times increase. In currently available devices, such an impact cannot have been significant enough to warrant overriding other considerations, such as patient comfort. It should be noted, however, that the various protrusion 305 designs disclosed herein can increase SNR while also preserving patient comfort.

[0113] Turning again to FIGS. 3A through 3C, an example heat sink 350a is also shown. The heat sink 350a can be attached to, or protrude from an outer surface of, the sensor 301a, thereby providing increased ability for various sensor components to dissipate excess heat. By being on the outer surface of the sensor 301a in certain embodiments, the heat sink 350a can be exposed to the air and thereby facilitate more efficient cooling. In an embodiment, one or more of the emitters (see FIG. 1) generate sufficient heat that inclusion of the heat sink 350a can advantageously allows the sensor 301a to remain safely cooled. The heat sink 350a can include one or more materials that help dissipate heat, such as, for example, aluminum, steel, copper, carbon, combinations of the same, or the like. For example, in some embodiments, the emitter shell 304a can include a heat conducting material that is also readily and relatively inexpensively moldable into desired shapes and forms.

[0114] In some embodiments, the heat sink 350a includes metallicized plastic. The metallicized plastic can include aluminum and carbon, for example. The material can allow for improved thermal conductivity and diffusivity, which can increase commercial viability of the heat sink. In some embodiments, the material selected to construct the heat sink 350a can include a thermally conductive liquid crystalline polymer, such as CoolPoly® D5506, commercially available from Cool Polymers®, Inc. of Warwick, R.I. Such a material can be selected for its electrically non-conductive and dielectric properties so as, for example, to aid in electrical shielding. In an embodiment, the heat sink 350a provides improved heat transfer properties when the sensor 301a is active for short intervals of less than a full day's use. In an embodiment, the heat sink 350a can advantageously provide improved heat transfers in about three (3) to about four (4) minute intervals, for example, although a heat sink 350a can be selected that performs effectively in shorter or longer intervals.

[0115] Moreover, the heat sink 350a can have different shapes and configurations for aesthetic as well as for functional purposes. In an embodiment, the heat sink is configured to maximize heat dissipation, for example, by maximizing surface area. In an embodiment, the heat sink 350a is molded into a generally curved surface and includes one or more fins, undulations, grooves, or channels. The example heat sink 350a shown includes fins 351a (see FIG. 3A).

[0116] An alternative shape of a sensor 301b and heat sink 350b is shown in FIG. 3D. The sensor 301b can include some or all of the features of the sensor 301a. For example, the sensor 301b includes an enclosure 302b formed by an emitter shell 304b and a detector shell 306b, pivotably connected about a pivot 303a. The emitter shell 304b can also include absorbing opaque material on one or more flaps 307b, and the

detector shell **306a** can also include absorbing opaque material at various areas, such as lower area **308b**.

[0117] However, the shape of the sensor **301b** is different in this embodiment. In particular, the heat sink **350b** includes comb protrusions **351b**. The comb protrusions **351b** are exposed to the air in a similar manner to the fins **351a** of the heat sink **350a**, thereby facilitating efficient cooling of the sensor **301b**.

[0118] FIG. 3E illustrates a more detailed example of a detector shell **306b** of the sensor **301b**. The features described with respect to the detector shell **306b** can also be used with the detector shell **306a** of the sensor **301a**.

[0119] As shown, the detector shell **306b** includes detectors **316**. The detectors **316** can have a predetermined spacing **340** from each other, or a spatial relationship among one another that results in a spatial configuration. This spatial configuration can purposefully create a variation of path lengths among detectors **316** and the emitter discussed above.

[0120] In the depicted embodiment, the detector shell **316** can hold multiple (e.g., two, three, four, etc.) photodiode arrays that are arranged in a two-dimensional grid pattern. Multiple photodiode arrays can also be useful to detect light piping (e.g., light that bypasses measurement site **102**). In the detector shell **316**, walls can be provided to separate the individual photodiode arrays to prevent or reduce mixing of light signals from distinct quadrants. In addition, the detector shell **316** can be covered by windows of transparent material, such as glass, plastic, or the like, to allow maximum or increased transmission of power light captured. In various embodiments, the transparent materials used can also be partially transparent or translucent or can otherwise pass some or all of the optical radiation passing through them. As noted, this window can include some shielding in the form of an embedded grid of wiring, or a conductive layer or coating.

[0121] As further illustrated by FIG. 3E, the detectors **316** can have a spatial configuration of a grid. However, the detectors **316** can be arranged in other configurations that vary the path length. For example, the detectors **316** can be arranged in a linear array, a logarithmic array, a two-dimensional array, or the like. Furthermore, any number of the detectors **316** can be employed in certain embodiments.

[0122] FIG. 3F illustrates another embodiment of a sensor **301f**. The sensor **301f** can include some or all of the features of the sensor **301a** of FIG. 3A described above. For example, the sensor **301f** includes an enclosure **302f** formed by an upper section or emitter shell **304f**, which is pivotably connected with a lower section or detector shell **306f** around a pivot point **303f**. The emitter shell **304f** can also include absorbing opaque material on various areas, such as on one or more flaps **307f**, to reduce ambient light entering the sensor **301f**. The detector shell **306f** can also include absorbing opaque material at various areas, such as a lower area **308f**. The sensor **301f** also includes a heat sink **350f**, which includes fins **351f**.

[0123] In addition to these features, the sensor **301f** includes a flex circuit cover **360**, which can be made of plastic or another suitable material. The flex circuit cover **360** can cover and thereby protect a flex circuit (not shown) that extends from the emitter shell **304f** to the detector shell **306f**. An example of such a flex circuit is illustrated in U.S. Publication No. 2006/0211924, incorporated above (see FIG. 46 and associated description, which is hereby specifically incorporated by reference). The flex circuit cover **360** is shown in more detail below in FIG. 17.

[0124] FIGS. 4A through 4C illustrate example arrangements of a protrusion **405**, which is an embodiment of the protrusion **305** described above. In an embodiment, the protrusion **405** can include a measurement site contact area **470**. The measurement site contact area **470** can include a surface that molds body tissue of a measurement site, such as a finger, into a flat or relatively flat surface.

[0125] The protrusion **405** can have dimensions that are suitable for a measurement site such as a patient's finger. As shown, the protrusion **405** can have a length **400**, a width **410**, and a height **430**. The length **400** can be from about 9 to about 11 millimeters, e.g., about 10 millimeters. The width **410** can be from about 7 to about 9 millimeters, e.g., about 8 millimeters. The height **430** can be from about 0.5 millimeters to about 3 millimeters, e.g., about 2 millimeters. In an embodiment, the dimensions **400**, **410**, and **430** can be selected such that the measurement site contact area **470** includes an area of about 80 square millimeters although larger and smaller areas can be used for different sized tissue for an adult, an adolescent, or infant, or for other considerations.

[0126] The measurement site contact area **470** can also include differently shaped surfaces that conform the measurement site into different shapes. For example, the measurement site contact area **470** can be generally curved and/or convex with respect to the measurement site. The measurement site contact area **470** can be other shapes that reduce or even minimize air between the protrusion **405** and the measurement site. Additionally, the surface pattern of the measurement site contact area **470** can vary from smooth to bumpy, e.g., to provide varying levels of grip.

[0127] In FIGS. 4A and 4C, openings or windows **420**, **421**, **422**, and **423** can include a wide variety of shapes and sizes, including for example, generally square, circular, triangular, or combinations thereof. The windows **420**, **421**, **422**, and **423** can be of non-uniform shapes and sizes. As shown, the windows **420**, **421**, **422**, and **423** can be evenly spaced out in a grid like arrangement. Other arrangements or patterns of arranging the windows **420**, **421**, **422**, and **423** are possible. For example, the windows **420**, **421**, **422**, and **423** can be placed in a triangular, circular, or linear arrangement. In some embodiments, the windows **420**, **421**, **422**, and **423** can be placed at different heights with respect to the finger bed **310** of FIG. 3. The windows **420**, **421**, **422**, and **423** can also mimic or approximately mimic a configuration of, or even house, a plurality of detectors.

[0128] FIGS. 6A through 6D illustrate another embodiment of a protrusion **605** that can be used as the tissue shaper **105** described above or in place of the protrusions **305**, **405** described above. The depicted protrusion **605** is a partially cylindrical lens having a partial cylinder **608** and an extension **610**. The partial cylinder **608** can be a half cylinder in some embodiments; however, a smaller or greater portion than half of a cylinder can be used. Advantageously, in certain embodiments, the partially cylindrical protrusion **605** focuses light onto a smaller area, such that fewer detectors can be used to detect the light attenuated by a measurement site.

[0129] FIG. 6A illustrates a perspective view of the partially cylindrical protrusion **605**. FIG. 6B illustrates a front elevation view of the partially cylindrical protrusion **605**. FIG. 6C illustrates a side view of the partially cylindrical protrusion **605**. FIG. 6D illustrates a top view of the partially cylindrical protrusion **605**.

[0130] Advantageously, in certain embodiments, placing the partially cylindrical protrusion **605** over the photodiodes

in any of the sensors described above adds multiple benefits to any of the sensors described above. In one embodiment, the partially cylindrical protrusion **605** penetrates into the tissue and reduces the pathlength of the light traveling in the tissue, similar to the protrusions described above.

**[0131]** The partially cylindrical protrusion **605** can also collect light from a large surface and focus down the light to a smaller area. As a result, in certain embodiments, signal strength per area of the photodiode can be increased. The partially cylindrical protrusion **605** can therefore facilitate a lower cost sensor because, in certain embodiments, less photodiode area can be used to obtain the same signal strength. Less photodiode area can be realized by using smaller photodiodes or fewer photodiodes (see, e.g., FIG. **14**). If fewer or smaller photodiodes are used, the partially cylindrical protrusion **605** can also facilitate an improved SNR of the sensor because fewer or smaller photodiodes can have less dark current.

**[0132]** The dimensions of the partially cylindrical protrusion **605** can vary based on, for instance, a number of photodiodes used with the sensor. Referring to FIG. **6C**, the overall height of the partially cylindrical protrusion **605** (measurement “a”) in some implementations is about 1 to about 3 mm. A height in this range can allow the partially cylindrical protrusion **605** to penetrate into the pad of the finger or other tissue and reduce the distance that light travels through the tissue. Other heights, however, of the partially cylindrical protrusion **605** can also accomplish this objective. For example, the chosen height of the partially cylindrical protrusion **605** can be selected based on the size of the measurement site, whether the patient is an adult or child, and so on. In an embodiment, the height of the protrusion **605** is chosen to provide as much tissue thickness reduction as possible while reducing or preventing occlusion of blood vessels in the tissue.

**[0133]** Referring to FIG. **6D**, the width of the partially cylindrical protrusion **605** (measurement “b”) can be about 3 to about 5 mm. In one embodiment, the width is about 4 mm. In one embodiment, a width in this range provides good penetration of the partially cylindrical protrusion **605** into the tissue to reduce the pathlength of the light. Other widths, however, of the partially cylindrical protrusion **605** can also accomplish this objective. For example, the width of the partially cylindrical protrusion **605** can vary based on the size of the measurement site, whether the patient is an adult or child, and so on. In addition, the length of the protrusion **605** could be about 10 mm, or about 8 mm to about 12 mm, or smaller than 8 mm or greater than 12 mm.

**[0134]** In certain embodiments, the focal length (*f*) for the partially cylindrical protrusion **605** can be expressed as:

$$f = \frac{R}{n-1},$$

where *R* is the radius of curvature of the partial cylinder **608** and *n* is the index of refraction of the material used. In certain embodiments, the radius of curvature can be between about 1.5 mm and about 2 mm. In another embodiment, the partially cylindrical protrusion **605** can include a material, such as nBK7 glass, with an index of refraction of around 1.5 at 1300 nm, which can provide focal lengths of between about 3 mm and about 4 mm.

**[0135]** A partially cylindrical protrusion **605** having a material with a higher index of refraction such as nSF11 glass (e.g., *n*=1.75 at 1300 nm) can provide a shorter focal length and possibly a smaller photodiode chip, but can also cause higher reflections due to the index of refraction mismatch with air. Many types of glass or plastic can be used with index of refraction values ranging from, for example, about 1.4 to about 1.9. The index of refraction of the material of the protrusion **605** can be chosen to improve or optimize the light focusing properties of the protrusion **605**. A plastic partially cylindrical protrusion **605** could provide the cheapest option in high volumes but can also have some undesired light absorption peaks at wavelengths higher than 1500 nm. Other focal lengths and materials having different indices of refraction can be used for the partially cylindrical protrusion **605**.

**[0136]** Placing a photodiode at a given distance below the partially cylindrical protrusion **605** can facilitate capturing some or all of the light traveling perpendicular to the lens within the active area of the photodiode (see FIG. **14**). Different sizes of the partially cylindrical protrusion **605** can use different sizes of photodiodes. The extension **610** added onto the bottom of the partial cylinder **608** is used in certain embodiments to increase the height of the partially cylindrical protrusion **605**. In an embodiment, the added height is such that the photodiodes are at or are approximately at the focal length of the partially cylindrical protrusion **605**. In an embodiment, the added height provides for greater thinning of the measurement site. In an embodiment, the added height assists in deflecting light piped through the sensor. This is because light piped around the sensor passes through the side walls of the added height without being directed toward the detectors. The extension **610** can also further facilitate the protrusion **605** increasing or maximizing the amount of light that is provided to the detectors. In some embodiments, the extension **610** can be omitted.

**[0137]** FIG. **6E** illustrates another view of the sensor **301f** of FIG. **3F**, which includes an embodiment of a partially cylindrical protrusion **605b**. Like the sensor **301A** shown in FIGS. **3B** and **3C**, the sensor **301f** includes a finger bed **310f**. The finger bed **310f** includes a generally curved surface shaped generally to receive tissue, such as a human digit. The finger bed **310f** also includes the ridges or channels **314** described above with respect to FIGS. **3B** and **3C**.

**[0138]** The example of finger bed **310f** shown also includes the protrusion **605b**, which includes the features of the protrusion **605** described above. In addition, the protrusion **605b** also includes chamfered edges **607** on each end to provide a more comfortable surface for a finger to slide across (see also FIG. **14D**). In another embodiment, the protrusion **605b** could instead include a single chamfered edge **607** proximal to the ridges **314**. In another embodiment, one or both of the chamfered edges **607** could be rounded.

**[0139]** The protrusion **605b** also includes a measurement site contact area **670** that can contact body tissue of a measurement site. The protrusion **605b** can be removed from or integrated with the finger bed **310f**. Interchangeable, differently shaped protrusions **605b** can also be provided, which can correspond to different finger shapes, characteristics, opacity, sizes, or the like.

**[0140]** FIGS. **7A** and **7B** illustrate block diagrams of sensors **701** that include example arrangements of conductive glass or conductive coated glass for shielding. Advantageously, in certain embodiments, the shielding can provide increased SNR. The features of the sensors **701** can be imple-

mented with any of the sensors **101**, **201**, **301** described above. Although not shown, the partially cylindrical protrusion **605** of FIG. **6** can also be used with the sensors **701** in certain embodiments.

[0141] For example, referring specifically to FIG. **7A**, the sensor **701a** includes an emitter housing **704a** and a detector housing **706**. The emitter housing **704a** includes LEDs **104**. The detector housing **706a** includes a tissue bed **710a** with an opening or window **703a**, the conductive glass **730a**, and one or more photodiodes for detectors **106** provided on a sub-mount **707a**.

[0142] During operation, a finger **102** can be placed on the tissue bed **710a** and optical radiation can be emitted from the LEDs **104**. Light can then be attenuated as it passes through or is reflected from the tissue of the finger **102**. The attenuated light can then pass through the opening **703a** in the tissue bed **710a**. Based on the received light, the detectors **106** can provide a detector signal **107**, for example, to the front end interface **108** (see FIG. **1**).

[0143] In the depicted embodiment, the conductive glass **730** is provided in the opening **703**. The conductive glass **730** can thus not only permit light from the finger to pass to the detectors **106**, but it can also supplement the shielding of the detectors **106** from noise. The conductive glass **730** can include a stack or set of layers. In FIG. **7A**, the conductive glass **730a** is shown having a glass layer **731** proximate the finger **102** and a conductive layer **733** electrically coupled to the shielding **790a**.

[0144] In an embodiment, the conductive glass **730a** can be coated with a conductive, transparent or partially transparent material, such as a thin film of indium tin oxide (ITO). To supplement electrical shielding effects of a shielding enclosure **790a**, the conductive glass **730a** can be electrically coupled to the shielding enclosure **790a**. The conductive glass **730a** can be electrically coupled to the shielding **704a** based on direct contact or via other connection devices, such as a wire or another component.

[0145] The shielding enclosure **790a** can be provided to encompass the detectors **106** to reduce or prevent noise. For example, the shielding enclosure **790a** can be constructed from a conductive material, such as copper, in the form of a metal cage. The shielding or enclosure can include an opaque material to not only reduce electrical noise, but also ambient optical noise.

[0146] Referring to FIG. **7B**, another block diagram of an example sensor **701b** is shown. A tissue bed **710b** of the sensor **701b** includes a protrusion **705b**, which is in the form of a convex bump. The protrusion **705b** can include all of the features of the protrusions or tissue shaping materials described above. For example, the protrusion **705b** includes a contact area **370** that comes in contact with the finger **102** and which can include one or more openings **703b**. One or more components of conductive glass **730b** can be provided in the openings **703**. For example, in an embodiment, each of the openings **703** can include a separate window of the conductive glass **730b**. In an embodiment, a single piece of the conductive glass **730b** can be used for some or all of the openings **703b**. The conductive glass **730b** is smaller than the conductive glass **730a** in this particular embodiment.

[0147] A shielding enclosure **790b** is also provided, which can have all the features of the shielding enclosure **790a**. The shielding enclosure **790b** is smaller than the shielding enclosure **790a**; however, a variety of sizes can be selected for the shielding enclosures **790**.

[0148] FIGS. **8A** through **8D** illustrate a perspective view, side views, and a bottom elevation view of the conductive glass described above with respect to the sensors **701a**, **701b**. As shown in the perspective view of FIG. **8A** and side view of FIG. **8B**, the conductive glass **730** includes the electrically conductive material **733** described above as a coating on the glass layer **731** described above to form a stack. In an embodiment where the electrically conductive material **733** includes indium tin oxide, surface resistivity of the electrically conductive material **733** can range approximately from 30 ohms per square inch to 500 ohms per square inch, or approximately 30, 200, or 500 ohms per square inch. As would be understood by a person of skill in the art from the present disclosure, other resistivities can also be used which are less than 30 ohms or more than 500 ohms. Other transparent, electrically conductive materials can be used as the material **733**.

[0149] Although the conductive material **733** is shown spread over the surface of the glass layer **731**, the conductive material **733** can be patterned or provided on selected portions of the glass layer **731**. Furthermore, the conductive material **733** can have uniform or varying thickness depending on a desired transmission of light, a desired shielding effect, and other considerations.

[0150] In FIG. **8C**, a side view of a conductive glass **830a** is shown to illustrate an embodiment where the electrically conductive material **733** is provided as an internal layer between two glass layers **731**, **835**. Various combinations of integrating electrically conductive material **733** with glass are possible. For example, the electrically conductive material **733** can be a layer within a stack of layers. This stack of layers can include one or more layers of glass **731**, **835**, as well as one or more layers of conductive material **733**. The stack can include other layers of materials to achieve desired characteristics.

[0151] In FIG. **8D**, a bottom perspective view is shown to illustrate an embodiment where a conductive glass **830b** can include conductive material **837** that occupies or covers a portion of a glass layer **839**. This embodiment can be useful, for example, to create individual, shielded windows for detectors **106**, such as those shown in FIG. **3C**. The conductive material **837** can be patterned to include an area **838** to allow light to pass to detectors **106** and one or more strips **841** to couple to the shielding **704** of FIG. **7**.

[0152] Other configurations and patterns for the conductive material can be used in certain embodiments, such as, for example, a conductive coating lining periphery edges, a conductive coating outlaid in a pattern including a grid or other pattern, a speckled conductive coating, coating outlaid in lines in either direction or diagonally, varied thicknesses from the center out or from the periphery in, or other suitable patterns or coatings that balance the shielding properties with transparency considerations.

[0153] FIG. **9** depicts an example graph **900** that illustrates comparative results obtained by an example sensor having components similar to those disclosed above with respect to FIGS. **7** and **8**. The graph **900** depicts the results of the percentage of transmission of varying wavelengths of light for different types of windows used in the sensors described above.

[0154] A line **915** on the graph **900** illustrates example light transmission of a window made from plain glass. As shown, the light transmission percentage of varying wavelengths of light is approximately 90% for a window made from plain



glass. A line 920 on the graph 900 demonstrates an example light transmission percentage for an embodiment in which a window is made from glass having an ITO coating with a surface resistivity of 500 ohms per square inch. A line 925 on the graph 900 shows an example light transmission for an embodiment in which a window is made from glass that includes a coating of ITO oxide with a surface resistivity of 200 ohms per square inch. A line 930 on the graph 900 shows an example light transmission for an embodiment in which a window is made from glass that includes a coating of ITO oxide with a surface resistivity of 30 ohms per square inch.

[0155] The light transmission percentage for a window with currently available embedded wiring can have a light transmission percentage of approximately 70%. This lower percentage of light transmission can be due to the opacity of the wiring employed in a currently available window with wiring. Accordingly, certain embodiments of glass coatings described herein can employ, for example, ITO coatings with different surface resistivity depending on the desired light transmission, wavelengths of light used for measurement, desired shielding effect, and other criteria.

[0156] FIGS. 10A through 10B illustrate comparative noise floors of example implementations of the sensors described above. Noise can include optical noise from ambient light and electromagnetic noise, for example, from surrounding electrical equipment. In FIG. 10A, a graph 1000 depicts possible noise floors for different frequencies of noise for an embodiment in which one of the sensors described above included separate windows for four (4) detectors 106. One or more of the windows included an embedded grid of wiring as a noise shield. Symbols 1030-1033 illustrate the noise floor performance for this embodiment. As can be seen, the noise floor performance can vary for each of the openings and based on the frequency of the noise.

[0157] In FIG. 10B, a graph 1050 depicts a noise floor for frequencies of noise 1070 for an embodiment in which the sensor included separate openings for four (4) detectors 106 and one or more windows that include an ITO coating. In this embodiment, a surface resistivity of the ITO used was about 500 ohms per square inch. Symbols 1080-1083 illustrate the noise floor performance for this embodiment. As can be seen, the noise floor performance for this embodiment can vary less for each of the openings and provide lower noise floors in comparison to the embodiment of FIG. 10A.

[0158] FIG. 11 illustrates an example structure for configuring the set of optical sources of the emitters described above. As shown, an emitter 1104 can include a driver 1111, a thermistor 1120, a set of top-emitting LEDs 1102 for emitting red and/or infrared light, a set of side-emitting LEDs 1104 for emitting near infrared light, and a submount 1106.

[0159] The thermistor 1120 can be provided to compensate for temperature variations. For example, the thermistor 1120 can be provided to allow for wavelength centroid and power drift of LEDs 1102 and 1104 due to heating. In addition, other thermistors (not shown) can be employed, for example, to measure a temperature of a measurement site. Such a temperature can be helpful in correcting for wavelength drift due to changes in water absorption, which can be temperature dependent, thereby providing more accurate data useful in detecting blood analytes like glucose.

[0160] The driver 1105 can provide pulses of current to the emitter 1104. In an embodiment, the driver 1105 drives the emitter 1104 in a progressive fashion for example, in an alternating manner based on a control signal from, for

example, a processor (e.g., the processor 110). For example, the driver 1105 can drive the emitter 1104 with a series of pulses to about 1 milliwatt (mW) for visible light to light at about 1300 nm and from about 40 mW to about 100 mW for light at about 1600 nm to about 1700 nm. However, a wide number of driving powers and driving methodologies can be used. The driver 1105 can be synchronized with other parts of the sensor and can minimize or reduce any jitter in the timing of pulses of optical radiation emitted from the emitter 1104. In some embodiments, the driver 1105 is capable of driving the emitter 1104 to emit an optical radiation in a pattern that varies by less than about 10 parts-per-million; however other amounts of variation can be used.

[0161] The submount 1106 provides a support structure in certain embodiments for aligning the top-emitting LEDs 1102 and the side-emitting LEDs 1104 so that their optical radiation is transmitted generally towards the measurement site. In some embodiments, the submount 1106 is also constructed of aluminum nitride (AlN) or beryllium oxide (BeO) for heat dissipation, although other materials or combinations of materials suitable for the submount 1106 can be used.

[0162] FIG. 12 illustrates a detector submount 1200 having photodiode detectors that are arranged in a grid pattern on the detector submount 1200 to capture light at different quadrants from a measurement site. One detector submount 1200 can be placed under each window of the sensors described above, or multiple windows can be placed over a single detector submount 1200. The detector submount 1200 can also be used with the partially cylindrical protrusion 605 described above with respect to FIG. 6.

[0163] The detectors include photodiode detectors 1-4 that are arranged in a grid pattern on the submount 1200 to capture light at different quadrants from the measurement site. As noted, other patterns of photodiodes, such as a linear row, or logarithmic row, can also be employed in certain embodiments.

[0164] FIG. 13 illustrates an example multi-stream process 1300. The multi-stream process 1300 can be implemented by the data collection system 100 and/or by any of the sensors described above. As shown, a control signal from a signal processor 1310 controls a driver 1305. In response, an emitter 1304 generates a pulse sequence 1303 from its emitter (e.g., its LEDs) into a measurement site or sites 1302. As described above, in some embodiments, the pulse sequence 1303 is controlled to have a variation of about 10 parts per million or less. Of course, depending on the analyte desired, the tolerated variation in the pulse sequence 1303 can be greater (or smaller).

[0165] In response to the pulse sequence 1300, detectors 1 to n (n being an integer) in a detector 1306 capture optical radiation from the measurement site 1302 and provide respective streams of output signals. Each signal from one of detectors 1-n can be considered a stream having respective time slots corresponding to the optical pulses from emitter sets 1-n in the emitter 1304. Although n emitters and n detectors are shown, the number of emitters and detectors need not be the same in certain implementations.

[0166] A front end interface 1308 can accept these multiple streams from detectors 1-n and deliver one or more signals or composite signal(s) back to the signal processor 1310. A stream from the detectors 1-n can thus include measured light intensities corresponding to the light pulses emitted from the emitter 1304.

[0167] The signal processor 1310 can then perform various calculations to measure the amount of glucose and other analytes based on these multiple streams of signals. In order to help explain how the signal processor 1310 can measure analytes like glucose, a primer on the spectroscopy employed in these embodiments will now be provided.

[0168] Spectroscopy is premised upon the Beer-Lambert law. According to this law, the properties of a material, e.g., glucose present in a measurement site can be deterministically calculated from the absorption of light traveling through the material. Specifically, there is a logarithmic relation between the transmission of light through a material and the concentration of a substance and also between the transmission and the length of the path traveled by the light. As noted, this relation is known as the Beer-Lambert law.

[0169] The Beer-Lambert law is usually written as:

$$\text{Absorbance } A = m * b * c, \text{ where:}$$

[0170]  $m$  is the wavelength-dependent molar absorptivity coefficient (usually expressed in units of  $M^{-1} \text{ cm}^{-1}$ );

[0171]  $b$  is the mean path length; and

[0172]  $c$  is the analyte concentration (e.g., the desired parameter).

[0173] In spectroscopy, instruments attempt to obtain the analyte concentration ( $c$ ) by relating absorbance ( $A$ ) to transmittance ( $T$ ). Transmittance is a proportional value defined as:

$$T = I/I_o, \text{ where:}$$

[0174]  $I$  is the light intensity measured by the instrument from the measurement site; and

[0175]  $I_o$  is the initial light intensity from the emitter.

[0176] Absorbance ( $A$ ) can be equated to the transmittance ( $T$ ) by the equation:

$$A = -\log T$$

[0177] Therefore, substituting equations from above:

$$A = -\log(I/I_o)$$

[0178] In view of this relationship, spectroscopy thus relies on a proportional-based calculation of  $-\log(I/I_o)$  and solving for analyte concentration ( $c$ ).

[0179] Typically, in order to simplify the calculations, spectroscopy will use detectors that are at the same location in order to keep the path length ( $b$ ) a fixed, known constant. In addition, spectroscopy will employ various mechanisms to definitively know the transmission power ( $I_o$ ), such as a photodiode located at the light source. This architecture can be viewed as a single channel or single stream sensor, because the detectors are at a single location.

[0180] However, this scheme can encounter several difficulties in measuring analytes, such as glucose. This can be due to the high overlap of absorption of light by water at the wavelengths relevant to glucose as well as other factors, such as high self-noise of the components.

[0181] Embodiments of the present disclosure can employ a different approach that in part allows for the measurement of analytes like glucose. Some embodiments can employ a bulk, non-pulsatile measurement in order to confirm or validate a pulsatile measurement. In addition, both the non-pulsatile and pulsatile measurements can employ, among other things, the multi-stream operation described above in order to attain sufficient SNR. In particular, a single light source having multiple emitters can be used to transmit light to multiple detectors having a spatial configuration.

[0182] A single light source having multiple emitters can allow for a range of wavelengths of light to be used. For example, visible, infrared, and near infrared wavelengths can be employed. Varying powers of light intensity for different wavelengths can also be employed.

[0183] Secondly, the use of multiple-detectors in a spatial configuration allow for a bulk measurement to confirm or validate that the sensor is positioned correctly. This is because the multiple locations of the spatial configuration can provide, for example, topology information that indicates where the sensor has been positioned. Currently available sensors do not provide such information. For example, if the bulk measurement is within a predetermined range of values, then this can indicate that the sensor is positioned correctly in order to perform pulsatile measurements for analytes like glucose. If the bulk measurement is outside of a certain range or is an unexpected value, then this can indicate that the sensor should be adjusted, or that the pulsatile measurements can be processed differently to compensate, such as using a different calibration curve or adjusting a calibration curve. This feature and others allow the embodiments to achieve noise cancellation and noise reduction, which can be several times greater in magnitude that what is achievable by currently available technology.

[0184] In order to help illustrate aspects of the multi-stream measurement approach, the following example derivation is provided. Transmittance ( $T$ ) can be expressed as:

$$T = e^{-m * b * c}$$

[0185] In terms of light intensity, this equation can also be rewritten as:

$$I/I_o = e^{-m * b * c}$$

[0186] Or, at a detector, the measured light ( $I$ ) can be expressed as:

$$I = I_o * e^{-m * b * c}$$

[0187] As noted, in the present disclosure, multiple detectors (1 to  $n$ ) can be employed, which results in  $I_1 \dots I_n$  streams of measurements. Assuming each of these detectors have their own path lengths,  $b_1 \dots b_n$ , from the light source, the measured light intensities can be expressed as:

$$I_n = I_o * e^{-m * b_n * c}$$

[0188] The measured light intensities at any two different detectors can be referenced to each other. For example:

$$I_1/I_n = (I_o * e^{-mb_1c}) / (I_o * e^{-mb_nc})$$

[0189] As can be seen, the terms,  $I_o$ , cancel out and, based on exponent algebra, the equation can be rewritten as:

$$I_1/I_n = e^{-m(b_1 - b_n)c}$$

[0190] From this equation, the analyte concentration ( $c$ ) can now be derived from bulk signals  $I_1 \dots I_n$  and knowing the respective mean path lengths  $b_1$  and  $b_n$ . This scheme also allows for the cancelling out of  $I_o$ , and thus, noise generated by the emitter 1304 can be cancelled out or reduced. In addition, since the scheme employs a mean path length difference, any changes in mean path length and topological variations from patient are easily accounted. Furthermore, this bulk-measurement scheme can be extended across multiple wavelengths. This flexibility and other features allow embodiments of the present disclosure to measure blood analytes like glucose.

[0191] For example, as noted, the non-pulsatile, bulk measurements can be combined with pulsatile measurements to more accurately measure analytes like glucose. In particular, the non-pulsatile, bulk measurement can be used to confirm or validate the amount of glucose, protein, etc. in the pulsatile measurements taken at the tissue at the measurement site(s) 1302. The pulsatile measurements can be used to measure the amount of glucose, hemoglobin, or the like that is present in the blood. Accordingly, these different measurements can be combined to thus determine analytes like blood glucose.

[0192] FIG. 14A illustrates an embodiment of a detector submount 1400a positioned beneath the partially cylindrical protrusion 605 of FIG. 6 (or alternatively, the protrusion 605b). The detector submount 1400a includes two rows 1408a of detectors 1410a. The partially cylindrical protrusion 605 can facilitate reducing the number and/or size of detectors used in a sensor because the protrusion 605 can act as a lens that focuses light onto a smaller area.

[0193] To illustrate, in some sensors that do not include the partially cylindrical protrusion 605, sixteen detectors can be used, including four rows of four detectors each. Multiple rows of detectors can be used to measure certain analytes, such as glucose or total hemoglobin, among others. Multiple rows of detectors can also be used to detect light piping (e.g., light that bypasses the measurement site). However, using more detectors in a sensor can add cost, complexity, and noise to the sensor.

[0194] Applying the partially cylindrical protrusion 605 to such a sensor, however, could reduce the number of detectors or rows of detectors used while still receiving the substantially same amount of light, due to the focusing properties of the protrusion 605 (see FIG. 14B). This is the example situation illustrated in FIG. 14—two rows 1408a of detectors 1410a are used instead of four. Advantageously, in certain embodiments, the resulting sensor can be more cost effective, have less complexity, and have an improved SNR, due to fewer and/or smaller photodiodes.

[0195] In other embodiments, using the partially cylindrical protrusion 605 can allow the number of detector rows to be reduced to one or three rows of four detectors. The number of detectors in each row can also be reduced. Alternatively, the number of rows might not be reduced but the size of the detectors can be reduced. Many other configurations of detector rows and sizes can also be provided.

[0196] FIG. 14B depicts a front elevation view of the partially cylindrical protrusion 605 (or alternatively, the protrusion 605b) that illustrates how light from emitters (not shown) can be focused by the protrusion 605 onto detectors. The protrusion 605 is placed above a detector submount 1400b having one or more detectors 1410b disposed thereon. The submount 1400b can include any number of rows of detectors 1410, although one row is shown.

[0197] Light, represented by rays 1420, is emitted from the emitters onto the protrusion 605. These light rays 1420 can be attenuated by body tissue (not shown). When the light rays 1420 enter the protrusion 605, the protrusion 605 acts as a lens to refract the rays into rays 1422. This refraction is caused in certain embodiments by the partially cylindrical shape of the protrusion 605. The refraction causes the rays 1422 to be focused or substantially focused on the one or more detectors 1410b. Since the light is focused on a smaller area, a sensor including the protrusion 605 can include fewer detectors to capture the same amount of light compared with other sensors.

[0198] FIG. 14C illustrates another embodiment of a detector submount 1400c, which can be disposed under the protrusion 605b (or alternatively, the protrusion 605). The detector submount 1400c includes a single row 1408c of detectors 1410c. The detectors are electrically connected to conductors 1412c, which can be gold, silver, copper, or any other suitable conductive material.

[0199] The detector submount 1400c is shown positioned under the protrusion 605b in a detector subassembly 1450 illustrated in FIG. 14D. A top-down view of the detector subassembly 1450 is also shown in FIG. 14E. In the detector subassembly 1450, a cylindrical housing 1430 is disposed on the submount 1400c. The cylindrical housing 1430 includes a transparent cover 1432, upon which the protrusion 605b is disposed. Thus, as shown in FIG. 14D, a gap 1434 exists between the detectors 1410c and the protrusion 605b. The height of this gap 1434 can be chosen to increase or maximize the amount of light that impinges on the detectors 1410c.

[0200] The cylindrical housing 1430 can be made of metal, plastic, or another suitable material. The transparent cover 1432 can be fabricated from glass or plastic, among other materials. The cylindrical housing 1430 can be attached to the submount 1400c at the same time or substantially the same time as the detectors 1410c to reduce manufacturing costs. A shape other than a cylinder can be selected for the housing 1430 in various embodiments.

[0201] In certain embodiments, the cylindrical housing 1430 (and transparent cover 1432) forms an airtight or substantially airtight or hermetic seal with the submount 1400c. As a result, the cylindrical housing 1430 can protect the detectors 1410c and conductors 1412c from fluids and vapors that can cause corrosion. Advantageously, in certain embodiments, the cylindrical housing 1430 can protect the detectors 1410c and conductors 1412c more effectively than currently-available resin epoxies, which are sometimes applied to solder joints between conductors and detectors.

[0202] In embodiments where the cylindrical housing 1430 is at least partially made of metal, the cylindrical housing 1430 can provide noise shielding for the detectors 1410c. For example, the cylindrical housing 1430 can be soldered to a ground connection or ground plane on the submount 1400c, which allows the cylindrical housing 1430 to reduce noise. In another embodiment, the transparent cover 1432 can include a conductive material or conductive layer, such as conductive glass or plastic. The transparent cover 1432 can include any of the features of the noise shields 790 described above.

[0203] The protrusion 605b includes the chamfered edges 607 described above with respect to FIG. 6E. These chamfered edges 607 can allow a patient to more comfortably slide a finger over the protrusion 605b when inserting the finger into the sensor 301f.

[0204] FIG. 14F illustrates a portion of the detector shell 306f, which includes the detectors 1410c on the substrate 1400c. The substrate 1400c is enclosed by a shielding enclosure 1490, which can include the features of the shielding enclosures 790a, 790b described above (see also FIG. 17). The shielding enclosure 1490 can be made of metal. The shielding enclosure 1490 includes a window 1492a above the detectors 1410c, which allows light to be transmitted onto the detectors 1410c.

[0205] A noise shield 1403 is disposed above the shielding enclosure 1490. The noise shield 1403, in the depicted embodiment, includes a window 1492a corresponding to the window 1492a. Each of the windows 1492a, 1492b can

include glass, plastic, or can be an opening without glass or plastic. In some embodiments, the windows **1492a**, **1492b** may be selected to have different sizes or shapes from each other.

[0206] The noise shield **1403** can include any of the features of the conductive glass described above. In the depicted embodiment, the noise shield **1403** extends about three-quarters of the length of the detector shell **306f**. In other embodiments, the noise shield **1403** could be smaller or larger. The noise shield **1403** could, for instance, merely cover the detectors **1410c**, the submount **1400c**, or a portion thereof. The noise shield **1403** also includes a stop **1413** for positioning a measurement site within the sensor **301f**. Advantageously, in certain embodiments the noise shield **1403** can reduce noise caused by light piping.

[0207] A thermistor **1470** is also shown. The thermistor **1470** is attached to the submount **1400c** and protrudes above the noise shield **1403**. As described above, the thermistor **1470** can be employed to measure a temperature of a measurement site. Such a temperature can be helpful in correcting for wavelength drift due to changes in water absorption, which can be temperature dependent, thereby providing more accurate data useful in detecting blood analytes like glucose.

[0208] In the depicted embodiment, the detectors **1410c** are not enclosed in the cylindrical housing **1430**. In an alternative embodiment, the cylindrical housing **1430** encloses the detectors **1410c** and is disposed under the noise shield **1403**. In another embodiment, the cylindrical housing **1430** encloses the detectors **1410c** and the noise shield **1403** is not used. If both the cylindrical housing **1403** and the noise shield **1403** are used, either or both can have noise shielding features.

[0209] FIG. **14G** illustrates the detector shell **306f** of FIG. **14F**, with the finger bed **310f** disposed thereon. FIG. **14H** illustrates the detector shell **306f** of FIG. **14G**, with the protrusion **605b** disposed in the finger bed **310f**.

[0210] FIG. **14I** illustrates a cutaway view of the sensor **301f**. Not all features of the sensor **301f** are shown, such as the protrusion **605b**. Features shown include the emitter and detector shells **304f**, **306f**; the flaps **307f**; the heat sink **350f** and fins **351f**; the finger bed **310f**; and the noise shield **1403**.

[0211] In addition to these features, emitters **1404** are depicted in the emitter shell **304f**. The emitters **1404** are disposed on a submount **1401**, which is connected to a circuit board **1419**. The emitters **1404** are also enclosed within a cylindrical housing **1480**. The cylindrical housing **1480** can include all of the features of the cylindrical housing **1430** described above. For example, the cylindrical housing **1480** can be made of metal, can be connected to a ground plane of the submount **1401** to provide noise shielding, and can include a transparent cover **1482**.

[0212] The cylindrical housing **1480** can also protect the emitters **1404** from fluids and vapors that can cause corrosion. Moreover, the cylindrical housing **1480** can provide a gap between the emitters **1404** and the measurement site (not shown), which can allow light from the emitters **1404** to even out or average out before reaching the measurement site.

[0213] The heat sink **350f**, in addition to including the fins **351f**, includes a protuberance **352f** that extends down from the fins **351f** and contacts the submount **1401**. The protuberance **352f** can be connected to the submount **1401**, for example, with thermal paste or the like. The protuberance **352f** can sink heat from the emitters **1404** and dissipate the heat via the fins **351f**.

[0214] FIGS. **15A** and **15B** illustrate embodiments of sensor portions **1500A**, **1500B** that include alternative heat sink features to those described above. These features can be incorporated into any of the sensors described above. For example, any of the sensors above can be modified to use the heat sink features described below instead of or in addition to the heat sink features of the sensors described above.

[0215] The sensor portions **1500A**, **1500B** shown include LED emitters **1504**; however, for ease of illustration, the detectors have been omitted. The sensor portions **1500A**, **1500B** shown can be included, for example, in any of the emitter shells described above.

[0216] The LEDs **1504** of the sensor portions **1500A**, **1500B** are connected to a substrate or submount **1502**. The submount **1502** can be used in place of any of the submounts described above. The submount **1502** can be a non-electrically conducting material made of any of a variety of materials, such as ceramic, glass, or the like. A cable **1512** is attached to the submount **1502** and includes electrical wiring **1514**, such as twisted wires and the like, for communicating with the LEDs **1504**. The cable **1512** can correspond to the cables **212** described above.

[0217] Although not shown, the cable **1512** can also include electrical connections to a detector. Only a portion of the cable **1512** is shown for clarity. The depicted embodiment of the cable **1512** includes an outer jacket **1510** and a conductive shield **1506** disposed within the outer jacket **1510**. The conductive shield **1506** can be a ground shield or the like that is made of a metal such as braided copper or aluminum. The conductive shield **1506** or a portion of the conductive shield **1506** can be electrically connected to the submount **1502** and can reduce noise in the signal generated by the sensor **1500A**, **1500B** by reducing RF coupling with the wires **1514**. In alternative embodiments, the cable **1512** does not have a conductive shield. For example, the cable **1512** could be a twisted pair cable or the like, with one wire of the twisted pair used as a heat sink.

[0218] Referring specifically to FIG. **15A**, in certain embodiments, the conductive shield **1506** can act as a heat sink for the LEDs **1504** by absorbing thermal energy from the LEDs **1504** and/or the submount **1502**. An optional heat insulator **1520** in communication with the submount **1502** can also assist with directing heat toward the conductive shield **1506**. The heat insulator **1520** can be made of plastic or another suitable material. Advantageously, using the conductive shield **1506** in the cable **1512** as a heat sink can, in certain embodiments, reduce cost for the sensor.

[0219] Referring to FIG. **15B**, the conductive shield **1506** can be attached to both the submount **1502** and to a heat sink layer **1530** sandwiched between the submount **1502** and the optional insulator **1520**. Together, the heat sink layer **1530** and the conductive shield **1506** in the cable **1512** can absorb at least part of the thermal energy from the LEDs and/or the submount **1502**.

[0220] FIGS. **15C** and **15D** illustrate implementations of a sensor portion **1500C** that includes the heat sink features of the sensor portion **1500A** described above with respect to FIG. **15A**. The sensor portion **1500C** includes the features of the sensor portion **1500A**, except that the optional insulator **1520** is not shown. FIG. **15D** is a side cutaway view of the sensor portion **1500C** that shows the emitters **1504**.

[0221] The cable **1512** includes the outer jacket **1510** and the conductive shield **1506**. The conductive shield **1506** is soldered to the submount **1502**, and the solder joint **1561** is

shown. In some embodiments, a larger solder joint **1561** can assist with removing heat more rapidly from the emitters **1504**. Various connections **1563** between the submount **1502** and a circuit board **1519** are shown. In addition, a cylindrical housing **1580**, corresponding to the cylindrical housing **1480** of FIG. **14I**, is shown protruding through the circuit board **1519**. The emitters **1504** are enclosed in the cylindrical housing **1580**.

[0222] FIGS. **15E** and **15F** illustrate implementations of a sensor portion **1500E** that includes the heat sink features of the sensor portion **1500B** described above with respect to FIG. **15B**. The sensor portion **1500E** includes the heat sink layer **1530**. The heat sink layer **1530** can be a metal plate, such as a copper plate or the like. The optional insulator **1520** is not shown. FIG. **15F** is a side cutaway view of the sensor portion **1500E** that shows the emitters **1504**.

[0223] In the depicted embodiment, the conductive shield **1506** of the cable **1512** is soldered to the heat sink layer **1530** instead of the submount **1502**. The solder joint **1565** is shown. In some embodiments, a larger solder joint **1565** can assist with removing heat more rapidly from the emitters **1504**. Various connections **1563** between the submount **1502** and a circuit board **1519** are shown. In addition, the cylindrical housing **1580** is shown protruding through the circuit board **1519**. The emitters **1504** are enclosed in the cylindrical housing **1580**.

[0224] FIGS. **15G** and **15H** illustrate embodiments of connector features that can be used with any of the sensors described above with respect to FIGS. **1** through **15F**. Referring to FIG. **15G**, the circuit board **1519** includes a female connector **1575** that mates with a male connector **1577** connected to a daughter board **1587**. The daughter board **1587** includes connections to the electrical wiring **1514** of the cable **1512**. The connected boards **1519**, **1587** are shown in FIG. **15H**. Also shown is a hole **1573** that can receive the cylindrical housing **1580** described above.

[0225] Advantageously, in certain embodiments, using a daughter board **1587** to connect to the circuit board **1519** can enable connections to be made more easily to the circuit board **1519**. In addition, using separate boards can be easier to manufacture than a single circuit board **1519** with all connections soldered to the circuit board **1519**.

[0226] FIGS. **16A** and **16B** illustrate embodiments of disposable optical sensors **1600**. In an embodiment, any of the features described above, such as protrusion, shielding, and/or heat sink features, can be incorporated into the disposable sensors **1600** shown. For instance, the sensors **1600** can be used as the sensors **101** in the system **100** described above with respect to FIG. **1**. Moreover, any of the features described above, such as protrusion, shielding, and/or heat sink features, can be implemented in other disposable sensor designs that are not depicted herein.

[0227] The sensors **1600** include an adult/pediatric sensor **1610** for finger placement and a disposable infant/neonate sensor **1602** configured for toe, foot or hand placement. Each sensor **1600** has a tape end **1610** and an opposite connector end **1620** electrically and mechanically interconnected via a flexible coupling **1630**. The tape end **1610** attaches an emitter and detector to a tissue site. Although not shown, the tape end **1610** can also include any of the protrusion, shielding, and/or heat sink features described above. The emitter illuminates the tissue site and the detector generates a sensor signal responsive to the light after tissue absorption, such as absorption by pulsatile arterial blood flow within the tissue site.

[0228] The sensor signal is communicated via the flexible coupling **1630** to the connector end **1620**. The connector end **1620** can mate with a cable (not shown) that communicates the sensor signal to a monitor (not shown), such as any of the cables or monitors shown above with respect to FIGS. **2A** through **2D**. Alternatively, the connector end **1620** can mate directly with the monitor.

[0229] FIG. **17** illustrates an exploded view of certain of the components of the sensor **301f** described above. A heat sink **1751** and a cable **1781** attach to an emitter shell **1704**. The emitter shell attaches to a flap housing **1707**. The flap housing **1707** includes a receptacle **1709** to receive a cylindrical housing **1480/1580** (not shown) attached to an emitter submount **1702**, which is attached to a circuit board **1719**.

[0230] A spring **1787** attaches to a detector shell **1706** via pins **1783**, **1785**, which hold the emitter and detector shells **1704**, **1706** together. A support structure **1791** attaches to the detector shell **1706**, which provides support for a shielding enclosure **1790**. A noise shield **1713** attaches to the shielding enclosure **1790**. A detector submount **1700** is disposed inside the shielding enclosure **1790**. A finger bed **1710** attaches to the noise shield **1703**. A partially cylindrical protrusion **1705** is disposed in the finger bed **1710**. Moreover, a flex circuit cover **1706** attaches to the pins **1783**, **1785**. Although not shown, a flex circuit can also be provided that connects the circuit board **1719** with the submount **1700** (or a circuit board to which the submount **1700** is connected).

[0231] Conditional language used herein, such as, among others, “can,” “could,” “might,” “may,” “e.g.,” and the like, unless specifically stated otherwise, or otherwise understood within the context as used, is generally intended to convey that certain embodiments include, while other embodiments do not include, certain features, elements and/or states. Thus, such conditional language is not generally intended to imply that features, elements and/or states are in any way required for one or more embodiments or that one or more embodiments necessarily include logic for deciding, with or without author input or prompting, whether these features, elements and/or states are included or are to be performed in any particular embodiment.

[0232] While certain embodiments of the inventions disclosed herein have been described, these embodiments have been presented by way of example only, and are not intended to limit the scope of the inventions disclosed herein. Indeed, the novel methods and systems described herein can be embodied in a variety of other forms; furthermore, various omissions, substitutions and changes in the form of the methods and systems described herein can be made without departing from the spirit of the inventions disclosed herein. The claims and their equivalents are intended to cover such forms or modifications as would fall within the scope and spirit of certain of the inventions disclosed herein.

What is claimed is:

1. A physiological sensor capable of outputting a signal responsive to a blood analyte present in a monitored patient, the sensor comprising:

- a sensor housing comprising an optical source configured to emit optical radiation on a body tissue of a medical patient;
- a heat sink associated with the sensor, the heat sink operative to receive thermal energy from the optical source and release thermal energy outside of the sensor housing; and

- a plurality of photodetectors each configured to detect the optical radiation from the optical source after attenuation by the body tissue of the medical patient and to output a signal responsive to the detected optical radiation, the signal reflecting one or more physiological parameters of the medical patient.
2. The sensor of claim 1, wherein the heat sink is at least partially exposed to air when the sensor is applied to the patient.
3. The sensor of claim 1, wherein the heat sink comprises a conductive shield of a medical cable, the conductive shield being in electrical communication with a substrate, the substrate being in electrical communication with the optical source.
4. The sensor of claim 3, further comprising an insulator connected to the substrate.
5. The sensor of claim 1, further comprising a heat sink layer in electrical communication with the substrate and the conductive shielding.
6. The sensor of claim 5, further comprising an insulator connected to the substrate and to the heat sink layer.
7. The sensor of claim 1, wherein the heat sink comprises one or more fins.
8. The sensor of claim 1, wherein the heat sink comprises a comb.
9. The sensor of claim 1, wherein the heat sink comprises a metalized plastic.
10. The sensor of claim 1, wherein the heat sink comprises carbon and aluminum material.
11. A physiological sensor capable of outputting a signal responsive to a blood analyte present in a monitored patient, the sensor comprising:  
 a sensor housing comprising an optical source configured to emit optical radiation on a body tissue of a medical patient, the optical source comprising one or more emitters disposed on a submount;
- a conductive shield of a medical cable configured to be in electrical communication with the submount, such that the conductive shield acts at least in part as a heat sink for the one or more emitters; and
- a plurality of photodetectors each configured to detect the optical radiation from the optical source after attenuation by the body tissue of the medical patient and to output a signal responsive to the detected optical radiation, the signal reflecting one or more physiological parameters of the medical patient.
12. The sensor of claim 11, wherein the conductive shield is soldered to the submount.
13. The sensor of claim 11, further comprising a heat sink layer connected to the submount.
14. The sensor of claim 13, wherein the conductive shield is soldered to the heat sink layer.
15. A heat sink of a noninvasive optical medical sensor capable of detecting light attenuated by body tissue, the heat sink comprising:  
 a heat producing part of an electronic device; and  
 a cable in thermal communication with the heat producing part, the cable comprising a conductor configured to draw heat from the heat producing part.
16. The heat sink of claim 15, wherein the conductor comprises shielding.
17. The heat sink of claim 15, wherein a portion of the shielding is thermally coupled with the heat producing part.
18. The heat sink of claim 15, wherein the conductor comprises a wire of a twisted pair of wires.
19. The heat sink of claim 15, further comprising a heat sink layer in thermal communication with the heat producing part and with the conductor.
20. The heat sink of claim 15, wherein the heat producing part comprises an emitter of an optical sensor.
21. The heat sink of claim 20, wherein the conductor is soldered to a submount of the emitter.

\* \* \* \* \*