

(19) World Intellectual Property Organization
International Bureau



(43) International Publication Date
25 September 2003 (25.09.2003)

PCT

(10) International Publication Number
WO 03/078252 A2

- (51) International Patent Classification⁷: **B65B**
- (21) International Application Number: PCT/US03/08298
- (22) International Filing Date: 14 March 2003 (14.03.2003)
- (25) Filing Language: English
- (26) Publication Language: English
- (30) Priority Data:
10/099,274 15 March 2002 (15.03.2002) US
10/099,771 15 March 2002 (15.03.2002) US
- (71) Applicant: **FUELSELL TECHNOLOGIES, INC.**
[US/US]; 601 Van Ness Avenue, Suite E3613, San Francisco, CA 94102 (US).

- (81) Designated States (*national*): AE, AG, AL, AM, AT, AU, AZ, BA, BB, BG, BR, BY, BZ, CA, CH, CN, CO, CR, CU, CZ, DE, DK, DM, DZ, EC, EE, ES, FI, GB, GD, GE, GH, GM, HR, HU, ID, IL, IN, IS, JP, KE, KG, KP, KR, KZ, LC, LK, LR, LS, LT, LU, LV, MA, MD, MG, MK, MN, MW, MX, MZ, NO, NZ, OM, PH, PL, PT, RO, RU, SD, SE, SG, SK, SL, TJ, TM, TN, TR, TT, TZ, UA, UG, UZ, VN, YU, ZA, ZM, ZW.
- (84) Designated States (*regional*): ARIPO patent (GH, GM, KE, LS, MW, MZ, SD, SL, SZ, TZ, UG, ZM, ZW), Eurasian patent (AM, AZ, BY, KG, KZ, MD, RU, TJ, TM), European patent (AT, BE, BG, CH, CY, CZ, DE, DK, EE, ES, FI, FR, GB, GR, HU, IE, IT, LU, MC, NL, PT, RO, SE, SI, SK, TR), OAPI patent (BF, BJ, CF, CG, CI, CM, GA, GN, GQ, GW, ML, MR, NE, SN, TD, TG).

Published:

— *without international search report and to be republished upon receipt of that report*

- (72) Inventor: **REDMOND, Scott, D.**; 601 Van Ness Avenue, Suite E3613, San Francisco, CA 94102 (US).
- (74) Agents: **MALLIE, Michael, J.** et al.; Blakely, Sokoloff, Taylor & Zafman LLP, 7th floor, 12400 Wilshire Boulevard, Los Angeles, CA 90025 (US).

For two-letter codes and other abbreviations, refer to the "Guidance Notes on Codes and Abbreviations" appearing at the beginning of each regular issue of the PCT Gazette.



WO 03/078252 A2

(54) Title: METHOD AND APPARATUS FOR A HYDROGEN FUEL CASSETTE DISTRIBUTION AND RECOVERY SYSTEM

(57) Abstract: A cassette-based hydrogen fuel distribution and recovery method and system is disclosed.

METHOD AND APPARATUS FOR A HYDROGEN FUEL CASSETTE DISTRIBUTION AND RECOVERY SYSTEM

FIELD OF INVENTION

The present invention relates to methods and means for distributing hydrogen fuel in a cassette form and recovering the hydrogen into useable fuel. The present invention also includes an information network in which user provided information related to fuel usage, tracking, and needs is communicated over a data network.

BACKGROUND OF INVENTION

It can be appreciated that alternative fuel systems have been in use for years, but certain problems have prevented mass adoption of such systems. Typically, alternative fuel systems are comprised of combustion-based engines requiring petroleum-based fuel, large pressurized gas tanks or liquid gas tanks requiring certain, specific, expensive, bulky and dangerous types of transportation and distribution infrastructure.

The main problems with conventional alternative fuel systems are that they have poor energy supply duration. They are massively inefficient, particularly so with gasoline. Their older technology is now moving at such a slow pace of development that it promises to reduce its already dramatic negatives for decades to come. They require high temperatures. They require friction mechanisms in the primary engine. Some conventional alternative fuel systems use hydrogen as a fuel, but liquid or compressed hydrogen has very unsafe handling characteristics. Conventional alternative fuel systems are hard to secure. They require large 3000+ PSI (pounds per square inch) gas cylinder trucks to move through cities or across domestic interstate routes. They use caustics or liquid electrolytes. They are usable as bombs by terrorists. In the conventional alternative fuel systems which use Methanol, while less polluting to reform into hydrogen than gasoline, Methanol is very toxic. Conventional alternative fuel systems produce carbon monoxide or carbon dioxide byproducts. They are not as reliable as a battery and don't have superior specific energy, energy density, and life cycle factors. They produce harmful emissions and noise. They cause potentially

planet-lethal global warming. They do not provide instantaneous startup. They cause fuel system congestion. Another problem with conventional alternative fuel systems is that current products do not exhibit portability over all systems and networks. Current products do not have enough end-user purchase location functionality, including delivery by conventional delivery services, such as Federal Express, United Parcel Service (UPS), and/or mail-order. Current products have extensive repair and maintenance needs. Current products are not simple and easy-to-use. Current products are hard to make standards compliant and interoperable. Current products produce reliance on foreign governments. Another problem with conventional alternative fuel systems are that they do not have attractive scaling economics. The current products do not expand in a more economical way than conventional batteries. Current products do not have superior distribution network efficiency and optimized raw materials utilization. Current products do not have a modular design that can be configured to suit any fuel distribution challenge. Conventional gasoline reformers are costly, bulky, energy consuming, and complex.

While these conventional systems, devices, and technologies devices may be suitable for the particular purpose to which they address, they are not suitable for compacting a large tank of hydrogen into a small unit of usable hydrogen fuel and managing, transporting, distributing and processing these materials. Recent political and global events have produced a sharply escalating demand for hydrogen supplies in extensive volumes.

Hydrogen is an abundant, clean, renewable fuel that has the potential to solve many of the world's energy and economic needs and energy-related problems. Although hydrogen is used in various applications, it has never become a major fuel source because of distribution issues associated with it. After years of development, hydrogen energy is now commercially viable in conventional fuel cell technology. However, safe and reliable, hydrogen storage and delivery is a main impediment to hydrogen becoming the world's primary fuel source.

Hydrogen is a very low-density material. Relatively small amounts require a voluminous transportation system. In the prior art, there has been no adequate solution for transporting, storing and distributing large volumes of hydrogen. Current methods generally require the storage of hydrogen in bulky and potentially explosive

tanks, the freezing of deadly liquids or the consumption of polluting hydrocarbon fuels. These highly pressurized and/or volatile devices are unsafe for many applications, such as in motorized vehicles.

Hydrogen, under ordinary conditions, is a colorless, odorless, tasteless, non-toxic gas comprised of diatomic molecules. There are many industrial uses of hydrogen including manufacturing ammonia and methanol, desulfurization of petroleum products, hydrogenation of fat and oils, production of electricity, and reduction of metallic oxide ores. Hydrogen, a flammable gas that diffuses rapidly in air, has a flammable range of approximately 4 percent to 94 percent by volume (vol. %), in air, at atmospheric pressure. Spark temperatures as low as 500 degrees C will initiate explosion of a hydrogen-air mixture. Consequently, the production and use of hydrogen is tightly controlled and regulated.

Laboratory scale, less than about 1 scfh hydrogen, systems exist which are comparatively simple and compact hydrogen fuel decompressing systems. In the commercial environment, however, strict regulations governing the production of hydrogen, in amounts exceeding about 100 scfh, for example, have increased the complexity, expense, and space requirement for these systems.

Hydrogen electrochemical systems of the prior art, including water electrolyzer systems for example, are commercially available in open metal frame structures. Systems of moderate and large capacity (greater than about 100 scfh of hydrogen) are typically integrated with separate power, control, ventilation, and heat exchange equipment when installed in a building or facility as a hydrogen fuel decompressing system. Due to the risk of an explosion of any uncontained hydrogen gas, the National Electric Code (Article 501), requires the use of explosion-proof methods when employing electrical equipment in hazardous environments. These methods include the use of explosion-proof housings, components, and certain energy limiting, "intrinsically safe", zener barrier devices, and often require housing of the fuel decompressor and associated equipment in special ventilated buildings or weatherized structures.

The hydrogen fuel decompressor systems of the prior art, which require explosion proof components and/or specialized housing, suffer from the fact that these components are more costly to procure and install, and typically require significantly

higher cost and effort to deploy than their non-explosion proof commercial counterparts.

Current Hydrogen supply can be described under three conventional models.

1. Traditional Model. Produce hydrogen, store hydrogen, transport hydrogen, use hydrogen
 - a. This model is expensive and dangerous. Unit costs for hydrogen increase as the hydrogen moves through the system towards use. It is also dangerous with pressurized hydrogen moving from refinery to point of use.
2. Hydrogen produced at point of use. Deliver fossil fuels to near usage site, produce hydrogen, use hydrogen at usage site.
 - a. This model uses energy intensive processes to produce hydrogen from fossil fuels. This is inefficient and creates pollution.
3. Hydrogen forced onto a hydride. Produce hydrogen, attach hydrogen to metals (producing hydrides), desorb hydrogen at usage
 - a. Again, hydrogen must be produced in order to adsorb it to a metal to produce the hydride. This is inefficient and currently dangerous.

What is needed in the art is a compact, reduced cost, reduced-size, self-contained, cassette-based hydrogen compression and decompression system configuration which meets the applicable codes and regulations, and can be utilized in hydrogen fuel decompressing systems and various fuel cell systems.

Thus, a readily portable unit of hydrogen fuel and a corresponding distribution and recovery method and system is needed.

SUMMARY OF INVENTION

The present invention is a cassette-based hydrogen fuel distribution and recovery method and system.

An object of the present invention is to provide a hydrogen core-state compression/decompression array and a system for compacting a large tank of hydrogen into a small unpressurized readily portable cassette and an automation unit for converting this hydrogen into usable hydrogen fuel and managing, transporting,

distributing and processing these materials. Another object is to provide a hydrogen core-state compression/decompression array that provides a unique cost-effective, safe, reliable and feasible alternative fuel production, transport & distribution technology for the world's energy needs. Another object is to provide a hydrogen core-state compression/decompression array that holds large amounts of hydrogen in a relatively small cassette. Another object is to provide a hydrogen core-state compression/decompression array that after transport, at the site that the fuel is required, turns the contents of the relatively small cassette back into usable alternative fuel. Another object is to provide a hydrogen core-state compression/decompression array that includes a software application to allow the distributors and the end-users to track, manage, order, pre-order, bill, allocate and provide other operation functions, in real-time, for the transport, distribution, supply, delivery and use of the alternative fuel in an integrated manner. Another object is to provide a hydrogen core-state compression/decompression array that uses hydride metals to densely pack hydrogen into a very small cassette as one of many possible cassette core materials via a process of enhanced catalyzation and layering of metallic hydride compounds at an atomic level. Another object is to provide a hydrogen core-state compression/decompression array that massively catalyzes water to make it function as a feasible medium for hydrogen fuel transport as one of the many possible cassette core materials via a process of Massively Catalyzed Water. Another object is to provide a hydrogen core-state compression/decompression array that can be affixed to a vehicle to turn the cassettes into usable hydrogen fuel on-board the vehicle. Another object is to provide a hydrogen core-state distribution system which is a load-responsive, hydrogen-on-demand solution. Another object is to provide a hydrogen core-state distribution system which uses no high heat, no liquid hydrogen and no high-pressure transport units. Another object is to provide a hydrogen core-state distribution system which may include fuel cells and self-contained full-circle energy production and reproduction. Another object is to provide a hydrogen core-state distribution system which can be small enough to be worn on a belt or large enough to power a large city like New York City. Another object is to provide a hydrogen core-state distribution system which eliminates the possibility of explosion from reactive or pressure causes. Another object is to provide a hydrogen core-state

distribution system which can be adapted easily to interface to all known fuel cell and hydrogen input needs. Another object is to provide a hydrogen core-state distribution system which may not require external power. Another object is to provide a hydrogen core-state distribution system which may provide reversible storage of hydrogen. Another object is to provide a hydrogen core-state distribution system which allows any consumer or business end-user to order fuel for direct delivery via a web-page or an 800 number. Another object is to provide a hydrogen core-state distribution system which will automatically re-supply all end users when they need more fuel. Another object is to provide a hydrogen core-state distribution system which Federal Aviation Administration (FAA) and National Transportation Safety Board (NTSB) certifiable and can be delivered by US Mail or purchased at your local Supermarket.

Other objects and advantages of the present invention will become apparent to the reader and it is intended that these objects and advantages are within the scope of the present invention.

BRIEF DESCRIPTION OF DRAWINGS

Various other objects, features and attendant advantages of the present invention will become fully appreciated as the same becomes better understood when considered in conjunction with the accompanying drawings, in which like reference characters designate the same or similar parts throughout the several views, and wherein:

Figure 1 is a figure of an Hfuel (hydrogen-rich core fuel material) cassette.

Figure 2 is a figure of a Decom (hydrogen decompression and recovery) unit.

Figures 3 and 4 illustrate embodiments of the Hfuel cassette.

Figures 5A-5F illustrate various types of Hfuel cassettes.

Figure 6 illustrates the components of one embodiment of the Decom unit.

Figures 7A-7D illustrate systems using fuel cassette clips.

Figure 8 illustrates the fabrication of a fuel cassette.

Figure 9 illustrates the further fabrication processes of a fuel cassette.

Figure 9 is a process drawing.

Figure 10 is a process for creating a Massively Catalyzed Water compound.

Figures 11A-11B illustrate an embodiment of a solid alloy type cassette.

Figures 12A-12B illustrate electrophilic addition energy.

Figures 13, 14, 15A-15B illustrate various embodiments for use in vehicles or other mobile platforms.

Figures 16A-16B illustrate a small version of the system for portable personal use.

Figures 17-20 illustrate the HNET Distribution Network Management Software/Central Controller of the present invention.

Figure 21 illustrates a conventional computer system.

Figure 22A and 22B illustrate a conventional computer network system.

Figures 23 and 24 illustrate an embodiment of web pages used with the present invention.

DETAILED DESCRIPTION OF THE PREFERRED EMBODIMENT(S)

A cassette-based hydrogen fuel distribution and recovery method and system is disclosed. In the following detailed description, numerous specific details are set forth in order to provide a thorough understanding of the present invention. However, it will be apparent to one of ordinary skill in the art that these specific details need not be used to practice the present invention. In other circumstances, well-known structures, compounds, circuits, processes and interfaces have not been shown or described in detail in order not to unnecessarily obscure the present invention.

As will be described in detail in the following sections, the present invention includes embodiments using "Smart-compression" technology and global common carrier

delivery of hydrogen direct to industry and consumers. These embodiments further include a unique, cost-effective, safe, reliable and feasible alternative fuel compression, transport and distribution technology. These embodiments further provide the transport, storage and distribution systems for hydrogen to charge fuel cells.

The present invention includes a novel fuel cassette technology which stores and safely transports hydrogen as a solid, liquid, slurry, or other form enabling the release of hydrogen directly into a conventional fuel cell on demand. There is no need for dangerous and expensive hydrogen distribution and delivery as is currently required.

As will be described in more detail below, the present invention stores the hydrogen in safe-to-transport readily portable un-pressurized cassettes. The energy potential of hydrogen is carried in the chemical bonds of the invented fuel cassettes core material, which, in the presence of a catalyst inside the invented decompression unit (Decom unit), releases hydrogen and produces electricity. The primary input components of the reaction are water or warm air and the invented fuel cassettes core material, the base form of which is found globally in substantial natural reserves. The structure and operation of the fuel cassettes and Decom unit of the present invention will be described in more detail below.

The system and methods of the present invention allow for the delivery of hydrogen (stored in Fuel Cassettes) via the traditional UPS, Postal or FedEx delivery systems. This ease of delivery revolutionizes the energy distribution and transport industries. The fuel cassettes of the present invention can be approved by the Department of Transportation, FAA, and NTSB as non-hazardous material and can be shipped anywhere at anytime.

As will be described in more detail below, the present invention has several advantages over conventional hydrogen fuel technology. The following list details several of the advantages.

1. Because the present invention holds hydrogen chemically during delivery and distributes hydrogen only when needed, storage and delivery is drastically safer than current solutions. This solves the storage and delivery problems of conventional systems.

2. Without costly production, storage, delivery costs, and operation costs, the present invention can deliver Hydrogen at many times lower costs than current market prices.
3. The hydrogen distributed by the present invention is 99.99% pure. Most hydrogen today comes from fossil fuel reformers that produce hydrogen from methane, gasoline, natural gas, or other fossil fuels. This conventional hydrogen is wasteful to produce and contains carbon monoxide that can poison some types of fuel cells if not removed.
4. The system and method of the present invention is infinitely scalable.
5. Business infrastructure in the present invention is from the point of presence.
6. Smart technology and fuel management software improve the efficient distribution system of the present invention.
7. Single use power cells that use the invented system to provide energy for the portable power markets, include laptop computers, cellular telephones, hearing aids, personal organizers and other portable devices.
8. The present invention can be used to sell hydrogen for use in traditional internal combustion engine devices. (Testing indicates 3x improvement in efficiency over gasoline)
9. Mass distribution through fleet refueling centers can be realized through the existing network of neighborhood gasoline stations and via UPS, Federal Express, US Postal mail and the neighborhood supermarket.
10. The fuel cassette core material of the present invention can be recycled.
11. In addition to safety and environmental advantages, the present invention has operating and manufacturing efficiencies superior to those of conventional technologies. In internal combustion engines, well-to-wheel efficiency is a common measure of how much energy is lost in the process of producing, refining, formulating and consuming a fuel. Our testing to date indicates that an internal combustion engine consuming hydrogen distributed from our fuel cassettes core material will provide a vehicle with significantly higher well-to-wheel efficiency than that of gasoline, while reducing greenhouse gas emissions. The system of the present invention, when used as a hydrogen source to power a fuel cell, is up to three times as efficient as gasoline.

A conventional fuel cell is a device that combines hydrogen, derived from a fuel such as natural gas, propane, methanol, gasoline, or other hydrogen fuel source, and oxygen from the air, to produce electric power without combustion. Conventional fuel cells are comprised of a thin, flat, multi-layered "sandwich". The 'sandwich' consists of two electrodes, an 'anode' and a 'cathode'. These two electrodes are typically separated by a plastic sheet (called a 'membrane' - the Membrane Electrode Assembly (MEA)). In simple terms, hydrogen enters the fuel cell, goes through the sandwich, hits an electric charge, exits the membrane into oxygen, becomes usable energy and creates its residue, basic water. A housing may contain many fuel cells (referred to as a "stack"), the hydrogen fuel (a bottle of varied sizes), and the unit's controls. The purpose of the controls is to start, stop and monitor the electricity produced by the collection of fuel cells (i.e. the stack).

In the small-scale commercial market, where sizes of fuel cells range from 25 watts to 250 kilowatts, the conventional fuel cell has been the type most tested and used in laboratories and in prototypes. The smaller size and lower temperature characteristics make conventional fuel cells ideal for use in vehicles, and therefore, much of the current testing to date in transportation markets has involved this type of fuel cell.

The conventional fuel cell requires hydrogen. Current methods of storing significant amounts of hydrogen in vehicles require use of large tanks of liquid (cryogenic) or compressed gaseous hydrogen. For a 3,000-pound automobile to achieve a range of 300 miles using a conventional fuel cell system, the equivalent of 32 twenty-five pound tanks (weighing 800 lbs.) of compressed gaseous hydrogen would be required. For cryogenically stored hydrogen, the weight drops significantly. However, though the weight of the overall system decreases, the overall energy efficiency does too. Approximately two-thirds of the total energy of the cryogenically stored hydrogen is required to liquefy the hydrogen. Both of these conventional systems are cumbersome, voluminous and potentially hazardous. An accident that damages a full tank of either liquid or gaseous hydrogen might result in an extremely powerful explosion. To date, we are unaware of better methods for storing significant amounts of hydrogen in a compact, lightweight and safe manner, which is National Transportation Safety Board, US Postal Service, Federal Aviation Administration and Department of Transportation safety approvable.

Hfuel Cassettes of One Embodiment

According to one embodiment of the present invention as shown in Figure 1, a compressed fuel cassette or module is shown. This cassette may be denoted herein as the cassette, module, hydrogen fuel cassette, or Hfuel cassette. In one embodiment, the cassette comprises a rigid outer casing defining one or more interior regions, which may be used to carry a core fuel, being solid, liquid, slurry, a hybrid or other form of hydrogen producing material. Another interior region of the cassette may be used for storage of exhaust/waste materials produced by the processes of the present invention. Alternatively, exhaust/waste materials may be stored in the same region previously used for storage of the core fuel material, once the core fuel material has been removed.

The Hfuel cassettes of the present invention are compound-agnostic. This means the core fuel in the cassette's interior region(s) may be any of a variety of hydrogen producing compounds. In one embodiment, the cassette includes a conventional electronic device 110 attached to the cassette, which can be used to store and process various items of information related to the cassette. This cassette information will be described in more detail below. In one embodiment, the cassette may also include a separate cassette type index or bar code 112, which defines the type characteristics of the cassette including the type of hydrogen compound the cassette carries. In other embodiments, the cassette type index is included with the cassette information stored on electronic device 110. The cassette may also include a memory and telemetry device 115 used to communicate cassette information back to a control software system. This control system is described in more detail below. Alternatively, the functionality of the device 115 may be incorporated into electronic device 110.

The Hfuel cassette is configured to fit into a cassette-receiving receptacle 215 of a Decom unit 210. See Figure 2. The Decom unit 210 recovers or decompresses the hydrogen core material compound from the cassette 220 and processes the compound into usable hydrogen fuel. In one embodiment, the cassette-receiving receptacle 215 or the cassette 220 itself includes a mounting frame into which a cassette may be inserted. See Figure 2. In another embodiment, shown in Figures 3 and 4, the cassette 100 includes an outer shell 310 and an internal tray 312, which holds a

package 410 containing the hydrogen fuel compound. In this configuration, the cassette is inserted into the receiving receptacle 215 of the Decom unit. The Decom unit slides open the tray 312 and the package 410 drops out of the cassette for processing by the Decom unit. After the fuel compound in the package is used by the Decom, the package 410 is automatically lifted back into tray 312. The tray 312 is then returned into outer shell 310 and the cassette 100 may be removed from the Decom unit.

In yet another embodiment, the cassette casing has a pivoted handle 222 at the front side, which separates the casing from the mounting frame or receiving receptacle for loading or unloading the core fuel in the cassette (see Figure 2). It will be apparent to those of ordinary skill in the art that many other equivalent cassette embodiments are possible.

In several embodiments of the present invention, there are at least five different types of cassettes. The outside of the cassette is generally the same for each type of cassette. The interior and the core material are different for each. The chip 110 and bar code 112 on each cassette tells the Decom unit which kind of cassette they are. The cassette receiving modules of the Decom are changed depending on which kind of cassettes one will be using. The primary materials from which cassettes are made include aluminum, plastic, and ceramic. Each cassette is configured to hold approximately 28 KW of releasable Hydrogen energy in various forms of core material.

Cassette types:

1. MCW (Massively Catalyzed Water) and Sodium Hydride or other water reactant. The MCW Liquid is specially compounded water for the core material of an Hfuel Cassette.
2. A mud-like slurry, which can flow through tubing inside the decom and contains water reactant.
3. Solid alloy. The Alloy material is specially compounded Metal Hydride alloy for the core material of an Hfuel Cassette.
4. Pre-sliced alloy
5. Powdered, charged, hydride

MCW Water

Massively Catalyzed Water can be created using the electromechanical process as follows (See also Figure 10):

1. Ozonize the water: The value of water is closely related to the “bond angle” between the two hydrogen atoms in the water molecule. Our Ozonation of water will result in a bond angle degree improvement.
2. Purify the water.
3. Introduce Atomic level amounts of specific materials to reduce the kinetics involved in the reaction.
4. Ionize the water.
5. Add extensive layers of catalysts to the water to achieve the best hydrogen release reaction for safest, lowest kinetic input, highest hydrogen output results. This will produce an acceptable MCW compound.

In other embodiments, other compounds (core materials) may be used in an Hfuel cassette. These other compounds include:

Low temperature metal hydrides

Alane Hydrides

Carbon Nanotubes

Carbon Fullerenes

Glass Microspheres

Water reactive slurries

Water Reactive catalysts

Decom Unit of One Embodiment

The Decom unit 210 recovers or decompresses hydrogen core fuel material and produces useable hydrogen fuel for insertion into or charging a removable conventional fuel cell or for direct hydrogen fuel output to a fuel-consuming device.

In one embodiment, the Decom unit includes its own fuel cell with a trickle charge battery that is fed from a limited percentage of the fuel cell so the Decom unit is self-powered in this configuration. Thus, embodiments of the Decom unit do not need external power. Other embodiments include a solar cell internal power source option. Other embodiments of the Decom provide various configurations for receiving cassettes. In some embodiments, the cassette receiving portion of the Decom can be

modularized for swap out and easy reconfiguration. The configurable Decom can receive fuel cassettes in several different optional ways. These configurations include:

- Single fuel cassette
- 12 pack fuel cassettes
- 6 pack fuel cassettes
- Radial 12 pack mount feeder
- Linear 6 pack mount feeder

In several embodiments of the Decom unit of the present invention, the Decom supplies High purity (99.999+ %) dry gaseous hydrogen output at production rates: .5 - 1 Nm³/h (19 to 38 scf/h) process pressure 10-250 PSIG for consumption at 15 to 20 SLPM at rated net output. The Decom in one embodiment is characterized as follows:

Features: No liquid hydrogen required, no pressurized hydrogen required, minimizes hydrogen inventory, no caustic electrolytes, no environmental impact, lower cost than competing solutions, asbestos free, reliable, compact; automatic control, no EMF, no external power required, easy to use, portable, weatherized casing option, vehicle-mountable.

Waste Emissions:

Liquid water: Maximum 0.87 liters (30 fluid oz.) per hour

Noise: 20 dBA @ 1 meter

Integration/connection: Fuel interface 45° flared tube fitting for ¼" OD tubing- metallic

Electrical interface: #8 AWG electrical wire

Control interface: Full duplex RS 485

Input: Water, as option

Output:

port1: Hydrogen

port2: Venting for overpressure:

port3: Modem

Communications: Memtel(TM) via CDPD wireless and/or modem

Communications connection:

One PCMCIA slot for Memtel wireless

One RJ-11 phone jack and modem

Input power: None

Functional Switches:

on/off, Eject, Test Cycle, Menu, >, <, Sleep

Indicator: Monochromatic LCD readout

It will be apparent to one of ordinary skill in the art that a particular Decom unit could be configured in various ways.

The Decom system is load responsive in that it produces hydrogen based upon demand by the fuel cell or Mem-Tel monitors on the energy-using device, engine or electronic appliances. The Decom unit contains a sub-module for containing pressurized hydrogen gas. There is a hydrogen relief valve and monitor system in all sections of the Decom system with containers which house hydrogen in a gaseous state. The alloy core material, in one configuration, uses extensively catalyzed hydride alloy compound. The MCW cassette or cassette section provides for liquid water-based compound storage. The Decom unit provides a system to move the alloy compound into contact with the water compound in a controlled manner so that hydrogen gas is desorbed or produced via the reaction. The Decom unit provides a means to move the gaseous state hydrogen to the fuel cell input port. The Decom unit has an optional thermal module to produce heat, which enhances the process of producing gas state hydrogen from the combination of compounds. The alloy core material in an alloy cassette or cassette section provides for the use of either calcium hydride, lithiumborohydride, sodium hydride, Sodium, Lithium, Potassium, Calcium, Calcium Hydride, Sodium Hydride, Lithium Hydride, fullerene hydride, sodium aluminum hydride, lithium hydride, lithium aluminum hydride, Magnesium hydride, Sodium Magnesium hydride, general metal hydride or similar compounds or alloys combined with an atomic level optimization using the P-C-P pincer complex. To produce the alloy base material, the pre-processing array of the Decom unit provides, as one option, a method for extracting sodium alloy from Methane and sodium hydroxide without high heat deployment but rather extensive chemical reaction via catalysts. The Decom/cassette system also provides for the use of a chemical hydride

slurry for the hydrogen carrier and storage medium. The slurry protects the hydride from contact with moisture and makes the hydride transportable over tubing, pipes and conduits. Upon reaching the location proximate to where the hydrogen will be used (use-nexus), a chemical hydride/water reaction is caused by the Decom unit to produce high purity hydrogen. The spent hydride is recovered by the system for reuse. Some versions of the cassettes have fuel cells within them and thus have a positive and negative power out connect on them. All Decom units have a power out, but the power in is always an optional module as the Decoms can be self-powered. The smallest system in one embodiment is a combined Decom and cassette holder with mini-fuel cell that can be worn on the belt and has a common DC adapter to power cell phones, pocket pc's, etc. This ultra small unit can be self-powered via piezo-electro energy pressure transducer worn in the heel section of the shoe or a kinetic energy device worn on the belt, which uses the motion of the body to charge a storage cell. A hydrogen generation system comprising an intelligent cassette containing base materials in either separate or combined cassettes, a water immersion container for receiving the contents of the cassette, an electronic circuit and or bar code and or data input/output (I/O) unit for reading the health, status, location, ID and volume of material of the cassette, including a cassette receiving aperture and a rotational or linear clip for multiple cassettes. An Infrared reader on the Decom unit, which is readable by the infrared (IR) device on IPAQ, Palm and similar handheld computers to allow the user to be their own "gas reader", and to interface with software on those devices for planning, management, billing and interaction with the network software. The use of carbon nanotube and doped carbon nanotube manifestation and development density increase and formation process in the alloy cassette production process in order to improve the effectiveness of the alloy base material. In a configuration using a solid alloy type cassette, the process of pre-slicing the rectangular blocks of alloy material inside the alloy cassettes or combination alloy/water cassettes and individually scraping those slices so as to allow a controlled released of the alloy into the water in a slice-by-slice method. Alternatively, the solid base material is ejected from the cassette into a processing module of the Decom unit, the Decom unit slicing system allowing a controlled released of the alloy to the water in a slice-by-slice method. The Decom unit stores

the alloy in the system out of immediate or accidental contact with water, which could cause a pressure explosion if alloy material were sitting in water without being processed, and controls the contact with water via the electromechanics of the Decom unit.

In the case of coatings on alloys stored in water or activating liquid, the coatings could degrade or, their could be a manufacturing error, which does occur in high volume production. If stored in water, the water could become contaminated and the coatings could suddenly degrade and cause a chain-reaction pressure and fire explosion. The Decom unit provides at least 3 levels of control and separation from the activating liquids in cassette versions, which use an alloy/water reaction process. The modularized Decom unit can be adapted easily to interface to all known fuel cell and hydrogen input needs. In the present invention, the alloy base material can be produced from many different alkali and alkaline earth metals and their related hydrides. The alloy base material can also use rare earth hydrides, which are different from alkali and alkaline earth metals and their related hydrides. Rare earth materials release hydrogen when they are heated. The Decom unit can deploy a thermal reaction chamber in the case of the rare earth hydrides. The recycle module in a Decom unit processes waste sodium hydroxide (NaOH) into sodium hydride (NaH) or similar recycling within the Decom system. The recycle module forms the waste NaOH, or other waste material, into a rectangular block, wraps the block, and insets that block into an empty cassette, a cassette which had just housed base material hydride, or similar material, for sale to an NaOH user, of which there are massive volumes in the world. The same cassettes can then be used to either remake base material or to be sold to a recycle center or sold directly to the paper, cosmetic, plastic and other industries who badly need NaOH. This makes the use of energy not only efficient and environmentally safe but also creates a revenue stream for the energy user. The core material alloy does not need to be a solid block of metal. It can be a chemical slurry or a powder. A cassette can be thermoformed from thin vinyl or acrylic. The information electronics, the identifier code, or Mem-Tel device could be applied to the cassette via adhesive and it could be sealed with a metalized paper or plastic covering over its aperture via an adhesive substrate. The user could pull off the adhesive sealant and push the cassette into the Decom aperture. Flanges in the

thermoformed plastic line up the cassette to the Decom input aperture mouth and an extraction arm pulls the core material inside into a receiving breach. The solid alloy type cassette has a rigid plastic cassette mouth but a flexible metalized fabric, Mylar, plastic/foil or similar robust yet lightweight thin skin or sheath housing. The user peels off a covering at the mouth, puts the mouth of the cassette against the aperture and pushes the other end of the cassette, causing the flexible outside covering to collapse accordion-like and drive the rigid internal material into the aperture. See Figures 11A and 11B. The cassette and the Decom unit are "hydride-agnostic", meaning that hydrides have an infinite variety of compound varieties. The system of the present invention provides reversible storage of hydrogen. Hydrides are doped in the preparation process with foreign metal compounds as one part of the hydride acceleration process. The belt mounted advanced Decom unit contains a battery for power storage, a fuel cell and a waste recycling module in highly miniature form. See Figures 16A-16C. The cassette supplies the water/hydride mix and can recycle internally for small loads or be removed at night and placed into a recycling-only version of the Decom unit to be fully charged for the next use period. In a solid alloy type cassette, the solid material in the cassette is pushed out, under Decom control on demand, by a conventional rotary-to-linear leadscrew drive pusher, as one possible option.

Turning now descriptively to the drawings, in which similar reference identifiers denote similar elements throughout the several views, the attached figures illustrate a hydrogen core-state distribution/recovery, compression/decompression array, which includes an Hfuel Alloy Cassette, Hfuel MCW (Massively Catalyzed Water) Cassette, Decom unit, Decom Home Unit, Memory Card, Hydrogen network distribution and central control software (H-Net), Processor Array, and Vehicle Decom unit. The Hfuel Alloy cassette is a relatively small container holding a specially compounded and chemically accelerated metal hydride alloy as a core material in a manner ready to be deployed by a Decom unit to extract the usable fuel. The Hfuel MCW cassette is a relatively small container holding specially compounded water as a core material in a manner ready to be deployed by a Decom unit to extract the usable fuel. We use a catalytic-process improvement for complex water compounds, which are used in our MCW cassettes. The Decom Unit is the automated fuel extraction device, into

which the Hfuel Cassettes are inserted. The Decom Home Unit is a very efficient, minimum-sized unit designed to connect at a user's home or office to their fuel cell fuel input or to have a fuel cell incorporated into it so that this version of the Decom can help the user to remove themselves from the local or regional power grid and supply and manage their own energy needs. The Memory and Telemetry device is an electronic circuit housed in a small package. It enables the Decom to read the current fuel usage and communicate that information back to the H-Net software database to help the distributor and the user to determine what the best delivery, distribution and management configuration is for their onsite energy system. The H-Net Software is a global database software package, which interacts with the distributors, management staff, the end user and the telemetry devices for integrated management, operations, ordering and scheduling of fuel. The Processing Array is the factory system designed to produce Hfuel Cassettes. The Vehicle Decom unit is a smaller device, which processes Hfuel Cassettes on board a vehicle and supplies the fuel directly to the vehicle fuel cell or engine system. It will be apparent to one of ordinary skill in the art that there are many possible structural and functional variations of the Hfuel cassette, the Decom unit, the Decom home unit, the Memory and Telemetry card, the H-Net software, the Processing array, and the vehicle decom unit. All such variations are within the scope of the invention disclosed and claimed herein.

The fuel cassette can hold either MCW liquid material or metallic alloy material but it does not need or require both materials. An Hfuel Cassette has very high gravimetric Hydrogen, or similar alternative fuel, density. It is produced at a low cost. It has very productive hydrogen, or similar alternative fuel, dissociation energetics. The weight percentage of usable fuel discharged from an Hfuel cassette is highly favorable from a thermodynamic standpoint at standard temperatures with very high kinetics and very feasible reversibility. The Alloy Cassettes can perform dehydrating and rehydrating effectively. Hfuel uses levels of catalysts to increase its effectiveness. There are many possible structural and functional variations to the Hfuel Cassette. In one such embodiment, the cassette has a metal or plastic housing. The housing is a preformed separate material or the internal core of the housing could be dipped into a plastic or metal compound, which would seal the core material within. The housing has an electronic circuit embedded in it, which assists the Decom unit in its process or

which assists the Memory Telemetry device in its process. The cassette may have rails, ridges, guides, depressions, recesses or ridges, which assist the Decom unit or the Processing array in organizing and handling the cassette. The cassette could have a housing in multiple parts, a doorway or an ability to be opened or broken by the Decom unit to expose the internal core material. In this version of the cassette, there is a metallic alloy, which is used as the core material of the cassette.

The Hfuel Alloy Cassette, or the Hfuel MCW (Massively Catalyzed Water) Cassette, Decom unit, Decom Home unit, Memory Card, H-Net Software, Processor Array, and Vehicle Decom unit, may all be interconnected parts of a unitized system of one embodiment. The system does not need to be unitized to work but functions best when unitized. The interconnections are the following: The Hfuel Cassette is produced from the Processor Array system. HFuel Cassettes can have a core material component composed of specially compounded water, specially compounded hydride chemicals or other matter as described above. The Hfuel Cassettes are loaded in any of a number of different sized Decom units that automatically process the core material in the cassettes to extract the usable hydrogen and provide it to a conventional fuel cell for use in an engine or device. A Decom unit or any unit that uses fuel can have a Memory card attached to it to monitor and advise, via telemetry, the status of the end-user fuel system. The H-Net Software receives data from the Memory Card and processes it via a database that helps end-users and distributors to manage and plan their fuel needs and operations. The Vehicle Decom is a miniaturized Cassette holder and processing unit with an integrated Memory Card, which locates the nearest hydrogen fuel source.

With respect to the above description then, it is to be realized that the optimum dimensional relationships for the parts of the invention, to include variations in size, materials, shape, form, function and manner of operation, assembly and use, are deemed readily apparent to one of ordinary skill in the art, and all equivalent relationships to those illustrated in the drawings and described in the specification are intended to be encompassed by the present invention.

Referring now to Figures 5A-5F, various embodiments of the fuel cassette of the present invention are illustrated. Referring to Figure 5A, a fuel cassette 505 is shown to include a region for the core material 510 from which the Hydrogen fuel

is recovered by the Decom unit 210. As further shown in Figure 5A, cassette 505 includes a memory chip 512 or other type of electronic device for retaining and processing information related to the cassette 505. The core material 510 and memory chip 512 are contained within a cassette housing 514 as shown in a plan view in Figure 5A and a side view in Figure 5B. As described above, core fuel material 510 may be any of a variety of Hydrogen fuel producing compounds including solid alloy and MCW, and other compounds described above. In Figure 5C, an embodiment is shown wherein a solid alloy core material 522 is contained within cassette 520. Once cassette 520 is inserted into the Decom unit 210, a plunger or push-rod 524 manipulated by Decom unit 210 is used to push the solid alloy core material 522 out of cassette 520 for processing and recovery by Decom unit 210. In one embodiment, foil end covers allow the core material to be pushed through and out into the processing section or stacker of Decom 210. In another embodiment shown in Figure 5D, the Decom unit 210 splits a cassette open at a predefined seam in order to access the core material 510 contained therein.

Alternatively, the core material can be manually pushed into the Decom processing section. As shown in Figure 5E, a cassette 530 is shown to contain MCW liquid core material 532. Upon insertion of cassette 530 into Decom unit 210, the MCW water is drained into the Decom unit 210 for processing and Hydrogen recovery via an outlet port on cassette 530. Referring to Figure 5F, another embodiment of the present invention is shown wherein cassette 540 is configured with multiple interior regions 542 and 544. In the embodiment shown, a first interior region 542 stores alloy material, for example, sodium hydride. In another interior region of cassette 540, the region 544 is used for storage of MCW material or other catalysts only. In this configuration, multiple interior regions of cassette 540 can be used to retain and keep separate two different materials which may be used in later processing steps by Decom unit 210.

Referring now to Figure 6, the modular structure of Decom unit 610 is illustrated. As shown in Figure 6, Decom unit 610 includes various functional blocks, which may be implemented as removable and reconfigurable modular components. For example, cassette intake and processor 612 (i.e. receiving receptacle) receives cassettes 605 for processing the core fuel material contained therein. Depending on the type of fuel

cassette being used by a particular Decom unit 610, the modular cassette intake and processor 612 may be interchanged and reconfigured to correspond with the particular type of fuel cassette 605 being used for a particular implementation. As an example, cassette intake and processor 612 may be configured to receive an MCW type fuel cassette 605. In this configuration, cassette intake and processor 612 would include necessary components for extracting the MCW core material from an input cassette 605. In another embodiment, cassette intake and processor 612 may be configured to receive solid alloy material from the input fuel cassette 605. In this configuration, cassette intake and processor 612 includes components for extracting solid alloy from the interior region of input cassette 605. Part of these components would include, in most embodiments, a push-rod 524 as shown in Figure 5C. It will be apparent to one of ordinary skill in the art that other modular cassette intake and processor 612 units may be employed to receive and extract core fuel materials of various types from input fuel cassette 605. Decom unit 610 also includes a water storage purification and catalyzing system 614. Decom unit 610 further includes recycle module 616. Decom unit 610 also includes process controller array 620 and transduction and flow control manifold 630 for controlling processes and activities performed within Decom unit 610. Decom unit 610 may also include thermal system 632 if heat is required for particular reactions or processes. A cooling system 634 may also be provided. Buffer tank 636 is also included in Decom unit 610. The Decom unit 610 further includes intensifier 638. Data processing within Decom unit 610 is handled by microprocessing unit 640 and communication with a data network is provided via a network connection. Venting valves 624 are provided to keep pressures within tolerance. Decom unit 610 may also include a conventional fuel cell 618 which may provide a trickle charge to trickle charge battery 622. In this manner, the Decom 610 can be self-powered.

Referring now to Fig. 7, the various alternative embodiments of Decom unit 610 are illustrated. In some applications, it may be necessary to load a plurality of fuel cassettes into a Decom unit via a clip to serially provide an ongoing source of fresh fuel cassettes. One such embodiment is illustrated in Fig. 7A. In Fig. 7A, a rotary style cassette clip 710 is shown. In this manner, a plurality of cassettes 705 may be loaded into a rotary cassette clip 710 and discharged one by one into the cassette

receiving receptacle of Decom unit 610. In this manner, a plurality of cassettes may be provided one after another to a Decom unit. In another alternative embodiment, Fig. 7B illustrates a stacked cassette clip 720. In this configuration, a plurality of fuel cassettes is stacked in a cassette clip 720 for sequential loading into the cassette receiving receptacle of Decom unit 610. As shown at block 722, a fuel cassette is extracted from cassette clip 720 and provided to the cassette receiving receptacle 612 of Decom unit 610. Upon receiving the fuel cassette, Decom unit 610 opens the cassette and accesses the electronic information device 110. The information related to the received cassette is read by the Decom unit 610 and the spent cassette housing is ejected to a recycle clip or to the top of the main clip 720. The core material extracted from the input cassette is sent to the activation process in block 723. As shown in Fig. 7C, the core material from the fuel cassette is processed by the Decom unit. As a result of the process, usable hydrogen fuel 728 is output by the Decom unit and may be loaded into a conventional fuel cell 734 or used directly. Concurrently, waste products produced by the creation of the hydrogen fuel are sent to a recycling module via block 730 and/or to a recycle process module 732. In this manner, waste products of the recovery of hydrogen fuel may be captured and separately processed by Decom unit 610. One embodiment of a Decom unit 740 is illustrated in Fig. 7D. Decom unit 740 includes an antenna and telemetry receiving device 742. Telemetry receiver 742 receives information wirelessly from fuel cassettes having a memory and telemetry device 115 embedded therein. The cassette related information is sent wirelessly to the Decom unit 740 and received by telemetry receiver 742. In this manner, a Decom unit can obtain cassette specific information which may be used later in processing a particular cassette or to aggregate information related to the fuel needs of a particular application. In the embodiment shown in Fig. 7D, Decom unit 740 further includes an infrared reader 746 for receiving information from remote or hand-held computing devices, which are well-known to those of ordinary skill in the art. Decom unit 740 may also be connected to a conventional telephone line or high speed data link for connection to a network information source or network server.

Referring now to Figure 8, a process for creating a fuel cassette in the system of the present invention is illustrated. As shown in blocks 812 and 813, various materials, which will be used as core fuel material in a particular cassette type configuration, are

gathered. In block 814, chemical and thermal enhancements of these base materials are performed. In block 816, high-speed catalyst compounds are added. In block 818, the processed core material is formed. Multi-layer packaging is performed in block 820. The processed material is inserted into a pre-formed cassette housing in block 822. In block 824, the core material is sealed into the cassette housing and the completed fuel cassette is inserted into a box for shipping in block 826.

Referring now to Figure 9, additional or alternative steps in cassette fabrication are illustrated. In block 910, a process initializer activates the collection of base materials in blocks 912, 914 and 916. These base materials are processed in block 918 where treatment of the compounds is handled and various additives are provided. Quality testing of the compound and fabricated cassette is performed in block 920. The electronic device 110 on the newly fabricated cassette can be programmed and/or read and related information transferred to a central fuel management database in block 922. The cassette is logged as inventory in block 924 and queued for transport and distribution in block 926. Waste reclaiming is handled in block 928.

Referring now to Figure 10, one process is illustrated for creating Massively Catalyzed Water for use as a core fuel material in the present invention. In block 1010, naturally occurring sea, lake, ground, storm, or other natural water sources are processed for purity to create natural water. In block 1012, ozonation optimization of bond angle between the H₂ atoms in the water molecule is handled. In block 1014, atomic amounts of specific materials are introduced. Ionization control is handled in block 1016. As a result, pure water combined with various catalysts are combined to create Massively Catalyzed Water 1020. The value of water is closely related to the bond angle between the two Hydrogen atoms in the water molecule. The ozonation process of the present invention results in a bond angle degree improvement.

Referring now to Figures 11A and 11B, an example illustrates one embodiment of a cassette 110 useful for handling solid alloy core fuel material. In the illustration shown in Figure 11A, a solid alloy type cassette 110 is shown prior to use in a Decom unit 610. Solid alloy cassette 1110 includes solid alloy core material 1112 contained therein. An outer housing of cassette 1110 may be fabricated from a collapsible material, which may be collapsed manually or by a push-rod 1114 activated by Decom unit 610. As Decom unit 610 applies pressure to push-rod 1114, the solid

alloy material 1112 is ejected from cassette 1110 and made accessible to Decom unit 610 for processing.

Referring to Figures 12A and 12B, as one part of the enhancement process, an example of electrophilic addition is illustrated. A resonance-stabilized allylic carbocation intermediate, which reacts with HCL forming two products. After the reaction proceeds, the less stable product requires less energy for formation and is formed much faster. A more stable product requires more energy and is slower in formation. We seek hereby to enhance instability in order to produce a faster formation requiring the least energy to form. We use this type of approach as one of the processes in enhancing metal hydrides and other Hydrogen fuel compression materials.

Reactions that involve kinetic control are influenced by the rates of formation, where thermodynamic control is influenced by the stability of each product. Electrophilic addition reactions can be controlled by the amount of time given for a reaction to occur. Under longer time periods, products that are formed slower and actually predominate in their reaction. An equilibrium will eventually be reached where the more stable product is present in larger amounts.

Referring now to Figure 13, an embodiment illustrates the use of a fuel cassette, Decom unit, and fuel cell in combination to produce a means for powering vehicles. In block 1310, a fuel cassette of the present invention can be sent by conventional package delivery services to any location at which a user may wish to use Hydrogen fuel for powering a device, such as a vehicle 1318. As shipped in standard ways, cassette 1312 can be proximately located to a consumer or user and a Decom unit 1314 also proximate to the consumer/user. The consumer receives the cassette 1312 and inserts the fuel cassette into Decom unit 1314 as described earlier in this document. Decom unit 1314 processes the core material on the received cassette 1312 and produces usable Hydrogen fuel as a result of the processing performed by Decom unit 1314. This usable fuel can be output to a conventional fuel cell 1316 which may thereafter be used to power a vehicle 1318 compatible with conventional fuel cell 1316 technology. In this manner, the present invention enables the remote delivery of Hydrogen core fuel material via cassette 1312 to a location proximate to use in a Hydrogen fuel-consuming device. Thus, the present invention enables the

widespread distribution of Hydrogen fuel core material using inexpensive and currently available conventional package delivery infrastructure.

Referring now to Figure 14, an embodiment of the present invention as used in an automobile is illustrated. As shown, an automobile trunk or hood section 1410 may be used for the storage of various components of the present invention. In particular, the vehicle may include a linear or rotary clip of Hfuel cassettes for serial loading into the vehicle mounted Decom unit 1420. An embodiment of linear or rotary clip cassette configurations was described above. In this manner, the vehicle mounted Decom unit 1420 may receive in serial fashion a plurality of Hfuel cassettes and thereby receive a steady supply of Hydrogen core fuel material for conversion to usable Hydrogen fuel, which may be output to the vehicle's conventional fuel cell 1414 or directly to the vehicle's engine. Thus, the present invention has application in powering vehicles using Hydrogen fuel.

Referring now to Figures 15A and 15B, diagrams illustrate a configuration of electronics and memory devices, which may be configured on an embodiment of an Hfuel cassette device 1510. A memory chip and processor 1516 on cassette 1510 can be used to retain and process information related to the energy contained within cassette 1510. This information can be conveyed via radio transceiver circuit 1518 to vehicle fuel sensors or filling station fuel sensors in block 1512. Further, this cassette information may be conveyed to a remotely located stand-alone Decom unit. In this manner, information specific to a particular Hfuel cassette unit may be sent remotely to a central information collection point for processing and combination with other system information. As shown in Figure 15B, fuel cassette 1520 may retain information including version number, production number, compound formulation, date, source identification data, and other information related to the characteristics and capacity of energy retained within the fuel cassette 1520.

Referring now to Figures 16A-16C, another embodiment of the present invention is illustrated. In this embodiment, a miniaturized fuel system can be configured for attachment to the belt of a wearer as shown in Figure 16C. Such a system may include the components illustrated in Figure 16A. For example, the system may include a fuel cassette 1610, a small Decom unit 1612, a fuel cell 1614, a recycle module 1616, battery 1618, and a control system and memory/telemetry circuit 1620.

As shown in Figure 16B, the system may be used to produce power in a very small and portable system configuration. In block 1630, manifold pressure transduction and flow meter absorption 1632 are provided to a purifying system 1634. Massively Catalyzed Water 1664 is provided to electrolyzer 1652 through flow meter 1662. Water is output to purifying system 1634 from electrolyzer 1652.

Thus, the Hfuel cassette and Decom units in various embodiments of the present invention are described above. These components may be combined into a larger Hydrogen fuel distribution and recovery system as will be described in more detail below in connection with Figures 17-20. As described above, the Hfuel cassettes of various embodiments of the present invention include electronic devices 110 for storage and processing of various information related to a specific cassette device. This information can be remotely transmitted via memory/telemetry device 115 to a Decom and/or centralized control facility, which may aggregate the information received from a plurality of fuel cassettes deployed at arbitrary locations remotely located from the central controller. In one embodiment of the present invention, the central controller function is handled by a global distribution network management software system (H-Net). The H-Net software system or central controller of one embodiment of the present invention will be described in more detail below. In general, the H-Net software system of one embodiment is responsible for collecting and efficiently managing the flow of Hydrogen fuel and corresponding Hfuel cassettes through a particular fuel distribution network.

Referring now to Figure 17, the block diagram structure of one perspective of the present invention is illustrated. The H-Net global distribution network management software system 1710 is shown as receiving input from a variety of sources. In particular, the central controller software 1710 receives information related to the fabrication or creation of new sets of each fuel cassettes. Specifically, information related to raw materials and the fabrication of raw materials into core fuel goods is conveyed to controller software 1710 from blocks 1712 and 1714. Further, management software 1710 receives information related to the core material inserted into cassettes and ready for distribution in inventory from blocks 1716 and 1718. In this manner, management software 1710 is able to retain information related to sets of fuel cassettes in inventory and ready for use by consumers. In blocks 1720, 1722,

1724, and 1726, the Hfuel cassettes in inventory may be consumed by consumers through various channels. Particularly, consumers may order small parcel delivery of fuel cassettes (block 1720). Additionally, consumers may order or obtain fuel cassettes via conventional filling stations in block 1722. In block 1724, the present invention also enables consumers to configure a fuel cassette and/or a Decom unit to automatically electronically convey ordering information to the management software 1710 or a local server, which may process fuel orders. In this manner, the consumer does not need to explicitly order new Hfuel cassettes when existing inventories of Hfuel cassettes have been exhausted. Upon consumption of available fuel cassette capacity, and if so configured for automatic ordering, the Hfuel cassette and/or Decom unit can automatically convey ordering information to management software 1710 via the memory/telemetry circuit 115 and/or microprocessing unit 640. Additionally, consumers may explicitly order fuel cassettes via conventional 800 telephone numbers, Internet accessible websites, or other conventional direct order techniques (block 1726). Additionally, management software 1710 receives information from Decom units deployed in various locations in a distribution network. For example, small business or large business Decom units may convey fuel usage and requirements information to management software 1710. Also, reseller and consumer Decom units may also convey similar information to management software 1710. Finally, management software 1710 may also receive and/or convey information between web and Internet data sources or other customer or supplier information sources (block 1738).

Referring now to Figure 18, a memory and telemetry communication and operations system of one embodiment of the present invention is illustrated. As shown in Figure 18, memory/telemetry devices either attached to stationary Decom units (block 1810) or detached to mobile Decom units (block 1812) may convey fuel cassette information to a central server 1814 using various wired and wireless conventional data communications techniques. This information aggregated by server 1814 may be communicated to a corporate central management facility, which manages the overall fuel distribution network. This aggregated information combined with other fuel distribution related information can be used to efficiently dispatch and control delivery and/or inventory of Hfuel cassettes throughout a fuel distribution network.

Referring now to Figure 19, a diagram illustrates the interaction between sales of and orders for fuel cassettes in a typical fuel distribution network of embodiments of the present invention.

Referring now to Figure 20, a diagram illustrates the typical flow of fuel-related information among a fuel distribution network. This network can include participants within a particular organization 2040 and/or other participants not part of the organization (2050). As described below, this fuel-related information can be conveyed among a large group of participants using conventional data network infrastructures.

Referring now to Figure 21, a diagram illustrates one embodiment of a network environment in which the present invention may operate. In this conventional network architecture, a server computer system 2100 is coupled to a wide-area network 2110. Wide-area network 2110 includes the Internet, or other proprietary networks including America On-Line™, CompuServe™, Microsoft Network™, and Prodigy™, each of which are well known to those of ordinary skill in the art. Wide-area network 2110 may include conventional network backbones, long-haul telephone lines, Internet service providers, various levels of network routers, and other conventional means for routing data between computers. Using conventional network protocols, server 2100 may communicate through wide-area network 2110 to a plurality of client computer systems 2120, 2130, 2140 connected through wide-area network 2110 in various ways. For example, client 2140 is connected directly to wide-area network 2110 through direct or dial-up telephone or other network transmission line. Alternatively, clients 2130 may be connected through wide-area network 2110 using a modem pool 2114. A conventional modem pool 2114 allows a plurality of client systems to connect with a smaller set of modems in modem pool 2114 for connection through wide-area network 2110. In another alternative network topology, wide-area network 2110 is connected to a gateway computer 2112. Gateway computer 2112 is used to route data to clients 2120 through a local area network (LAN) 2116. In this manner, clients 2120 can communicate with each other through local area network 2116 or with server 2100 through gateway 2112 and wide-area network 2110.

Using one of a variety of network connection means, server computer 2100 can

communicate with client computers 2150 using conventional means. In a particular implementation of this network configuration, a server computer 2100 may operate as a web server if the World-Wide Web (WWW) portion of the Internet is used for wide area network 2110. Using the HTTP protocol and the HTML or XML coding language across wide-area network 2110, web server 2100 may communicate across the World-Wide Web with clients 2150. In this configuration, clients 2150 use a client application program known as a web browser such as the Netscape™ Navigator™ formerly published by Netscape Corporation of Mountain View, CA, the Internet Explorer™ published by Microsoft Corporation of Redmond, Washington, the user interface of America On-Line™, or the web browser or HTML/XML translator or any other well-known supplier. Using such conventional browsers and the World-Wide Web, clients 2150 may access image, graphical, and textual data provided by web server 100 or run Web application software. Conventional means exist by which clients 2150 may supply information to web server 2100 through the World-Wide Web 2110 and the web server 2100 may return processed data to clients 2150.

Having briefly described one embodiment of a network environment in which the present invention may operate, Figs. 22A and 22B illustrate an example of a computer system 2200 illustrating an exemplary client 2150 or server 2100 computer system in which the features of the present invention may be implemented. Computer system 2200 is comprised of a data bus or other communications means 2214 and 2216 for communicating information, and a processing means such as processor 2220 coupled with bus 2214 for processing information. Computer system 2200 further comprises a random access memory (RAM) or other dynamic storage device 2222 (commonly referred to as main memory), coupled to bus 2214 for storing information and instructions to be executed by processor 2220. Main memory 2222 also may be used for storing temporary variables or other intermediate information during execution of instructions by processor 2220. Computer system 2200 may also comprise a read only memory (ROM) and /or other static storage device 2224 coupled to bus 2214 for storing static information and instructions for processor 2220. An optional data storage device 2212 such as a magnetic disk or optical disk and its corresponding drive 2228 may also be coupled to computer system 2200 for storing

information and instructions. Computer system 2200 can also be coupled via bus 2216 to a display device 2204, such as a cathode ray tube (CRT) or a liquid crystal display (LCD), for displaying information to a computer user. For example, image, textual, or graphical depictions of data and other types of image, graphical, or textual information may be presented to the user on display device 2204. Typically, an alphanumeric input device 2208, including alphanumeric and other keys is coupled to bus 2216 for communicating information and/or command selections to processor 2220. Another type of user input device is cursor control device 2206, such as a conventional mouse, trackball, or other type of cursor direction keys for communicating direction information and command selection to processor 2220 and for controlling cursor movement on display 2204.

Alternatively, the client 2150 can be implemented as a network computer or thin client device, such as the WebTV Networks[™] Internet terminal, the Oracle[™] NC, a personal digital assistant (PDA), or mobile communication device, such as a cellular telephone. Client 2150 may also be a laptop or palm-top computing device, such as the Palm Pilot[™]. Client 2150 could also be implemented in a robust cellular telephone, where such devices are currently being used with Internet micro-browsers. Such a network computer or thin client device does not necessarily include all of the devices and features of the above-described exemplary computer system; however, the functionality of the present invention or a subset thereof may nevertheless be implemented with such devices.

A communication device 2226 is also coupled to bus 2216 for accessing remote computers or servers, such as web server 2100, or other servers via the Internet, for example. The communication device 2226 may include a modem, a network interface card, or other well-known interface devices, such as those used for interfacing with Ethernet, Token-ring, or other types of networks. In any event, in this manner, the computer system 2200 may be coupled to a number of servers 2100 via a conventional network infrastructure such as the exemplary infrastructure illustrated in Figure 21 and described above.

The system of the present invention includes software implemented on information processing hardware and using various processing steps, which are described above. The features and process steps of the present invention may be embodied in machine

or computer executable instructions. The instructions can be used to cause a general purpose or special purpose processor, which is programmed with the instructions to perform the steps of the present invention. Alternatively, the features or steps of the present invention may be performed by specific hardware components that contain hard-wired logic for performing the steps, or by any combination of programmed computer components and custom hardware components. While embodiments of the present invention will be described with reference to the World-Wide Web, the method and apparatus described herein is equally applicable to other network infrastructures or other data communications systems.

Referring now to Figures 23 and 24, conventional HTML web pages illustrate one embodiment of a user interface for accessing information related to the hydrogen fuel distribution and recovery system of the present invention. As shown in Figure 23, users of the hydrogen fuel distribution system of the present invention may access the system as members of various groups identified as industrial users, resellers, consumers, or hydrogen team (H-team) members. Using conventional web or network technology, users accessing the fuel distribution website may create user accounts and log in as specified users under user identifiers and passwords. Once identified to the system as a identified user, the typical web interface illustrated in Figure 24 can be displayed. In such a typical web user interface, a user of the fuel distribution system of the present invention may access various items of functionality provided by the system. For example, a user may determine the daily usage of hydrogen fuel as that information is provided through usage of fuel cassettes with electronic devices identifying usage throughout a system. Additionally, a user may request various information reports created by the system which highlight and report a variety of information including fuel usage, availability, distribution, and status. Additionally, a user may determine when the system has determined a new reload of hydrogen fuel may be required at a particular location. This information is determined based on the current consumption, current availability, and rate of consumption as determined by the reporting provided by individual Hfuel cassettes and the processing performed by corresponding Decom units. This availability and processing information is conveyed to the central controller software via the network interface of various Decom units distributed throughout the system. It will be

apparent to one of ordinary skill in the art that other types of information may be collected and reported via the typical network user interface illustrated by example in Figures 23 and 24.

Thus, a cassette-based hydrogen fuel distribution and recovery method and system is disclosed. Although the present invention is described herein with reference to a specific preferred embodiment, many modifications and variations therein will readily occur to those with ordinary skill in the art. Accordingly, all such variations and modifications are included within the intended scope of the present invention as defined by the following claims.

CLAIMS

What is claimed is:

1. A cassette-based hydrogen fuel distribution and recovery system comprising:
 - a hydrogen fuel cassette, the fuel cassette including a core fuel material; and
 - a decom unit to receive the fuel cassette, to recover hydrogen-based fuel from the core fuel material of the fuel cassette, and to provide the hydrogen-based fuel as output.
2. A hydrogen fuel cassette comprising:
 - a housing defining at least one interior region; and
 - a core fuel material stored in the interior region.
3. The hydrogen fuel cassette of claim 2 further including an electronic device to store information related to the cassette.
4. The hydrogen fuel cassette of claim 2 further including a memory and telemetry circuit to transmit fuel cassette information to a remote receiver.
5. The hydrogen fuel cassette of claim 2 wherein the core fuel material is massively catalyzed water.
6. The hydrogen fuel cassette of claim 2 wherein the core fuel material is solid alloy.
7. A hydrogen decompression (decom) unit comprising:
 - a hydrogen fuel cassette receiving module to receive a removably insertable hydrogen fuel cassette having a core fuel material therein;
 - a processing module to extract core fuel material from the hydrogen fuel cassette and to convert the core fuel material into hydrogen fuel; and
 - an output port to transfer out the processed hydrogen fuel.
8. The hydrogen decompression (decom) unit of claim 7 further including an integrated fuel cell to self-power the decom unit.

9. The hydrogen decompression (decom) unit of claim 7 wherein the core fuel material is massively catalyzed water.
10. The hydrogen decompression (decom) unit of claim 7 wherein the core fuel material is solid alloy.
11. A cassette-based hydrogen fuel distribution and recovery system comprising:
 - a hydrogen fuel cassette, the fuel cassette including a core fuel material;
 - a decom unit to receive the fuel cassette, to recover hydrogen-based fuel from the core fuel material of the fuel cassette, and to provide the hydrogen-based fuel as output; and
 - a central controller to receive information from the hydrogen fuel cassette or the decom unit and to aggregate fuel distribution information for a user.
12. The cassette-based hydrogen fuel distribution and recovery system of claim 11 wherein the hydrogen fuel cassette includes a memory and telemetry device to transmit fuel cassette information to a remote receiver.
13. The cassette-based hydrogen fuel distribution and recovery system of claim 11 wherein the decom unit further includes a network connection to interface with the central controller via a data network.
14. The cassette-based hydrogen fuel distribution and recovery system of claim 11 wherein the central controller further includes functionality with which a user may monitor hydrogen fuel consumption.
15. The cassette-based hydrogen fuel distribution and recovery system of claim 11 wherein the user may order fuel using the central controller.
16. The cassette-based hydrogen fuel distribution and recovery system of claim 11 wherein the user may determine a refueling time using the central controller.

17. The cassette-based hydrogen fuel distribution and recovery system of claim 11 wherein the central controller automatically orders additional fuel cassettes when needed.
18. The cassette-based hydrogen fuel distribution and recovery system of claim 11 wherein a user may negotiate with others to sell a portion of energy generated by the Decom unit.
19. The cassette-based hydrogen fuel distribution and recovery system of claim 11 wherein the core material is massively catalyzed water.
20. The cassette-based hydrogen fuel distribution and recovery system of claim 11 wherein the core material is solid alloy.

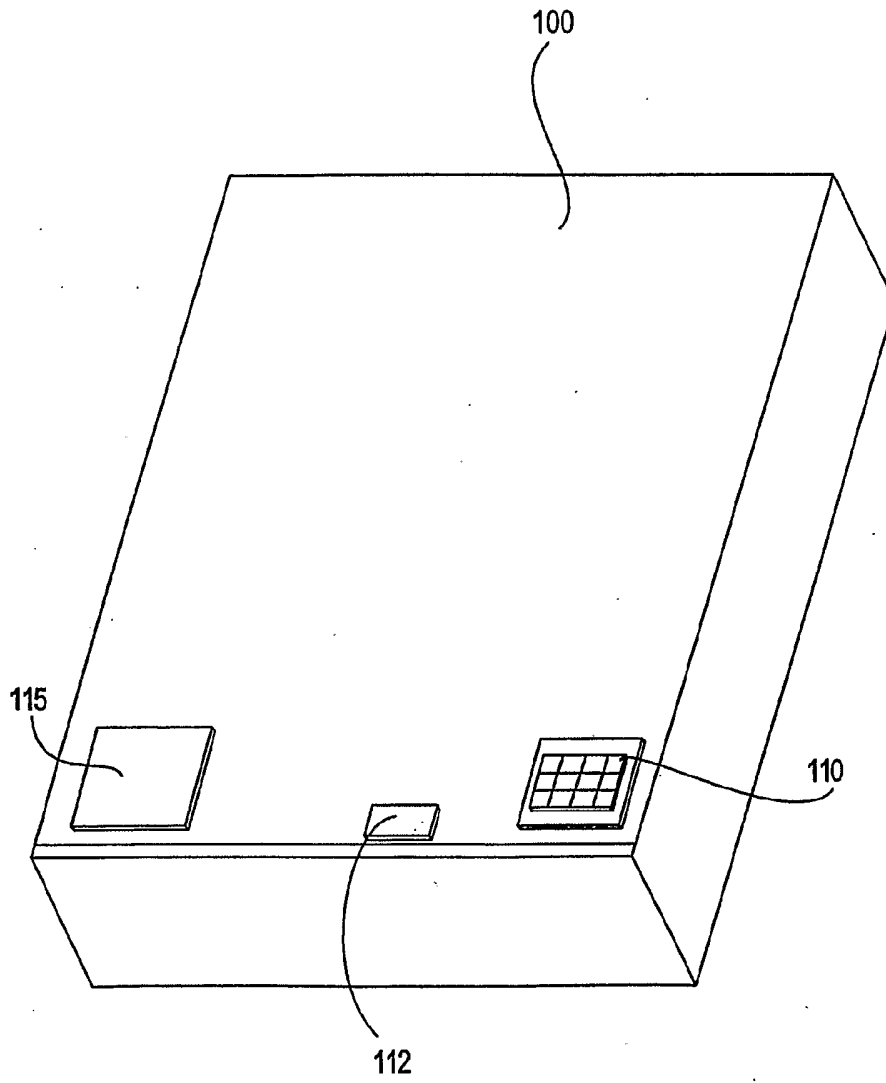

Fig. 1

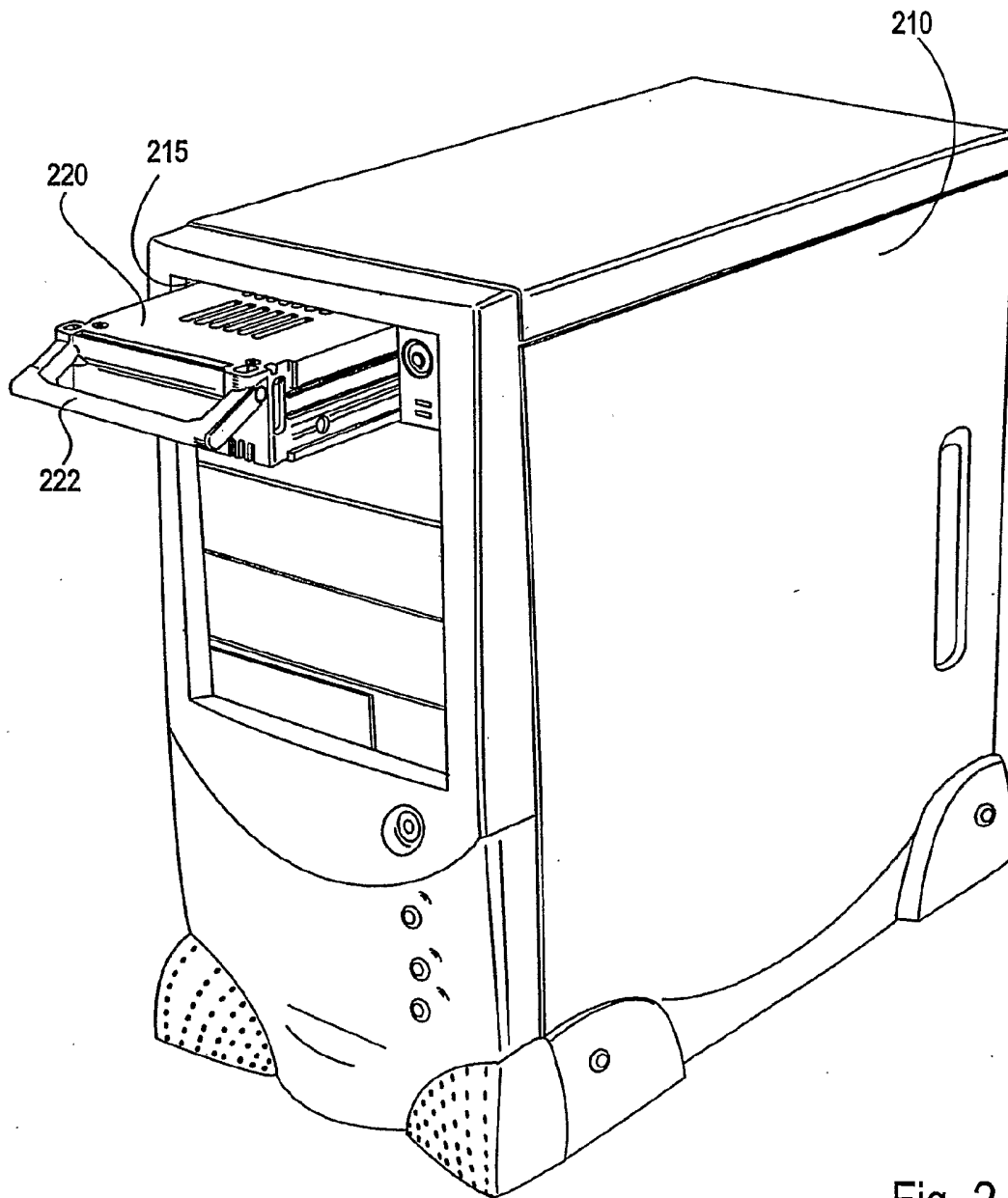

Fig. 2

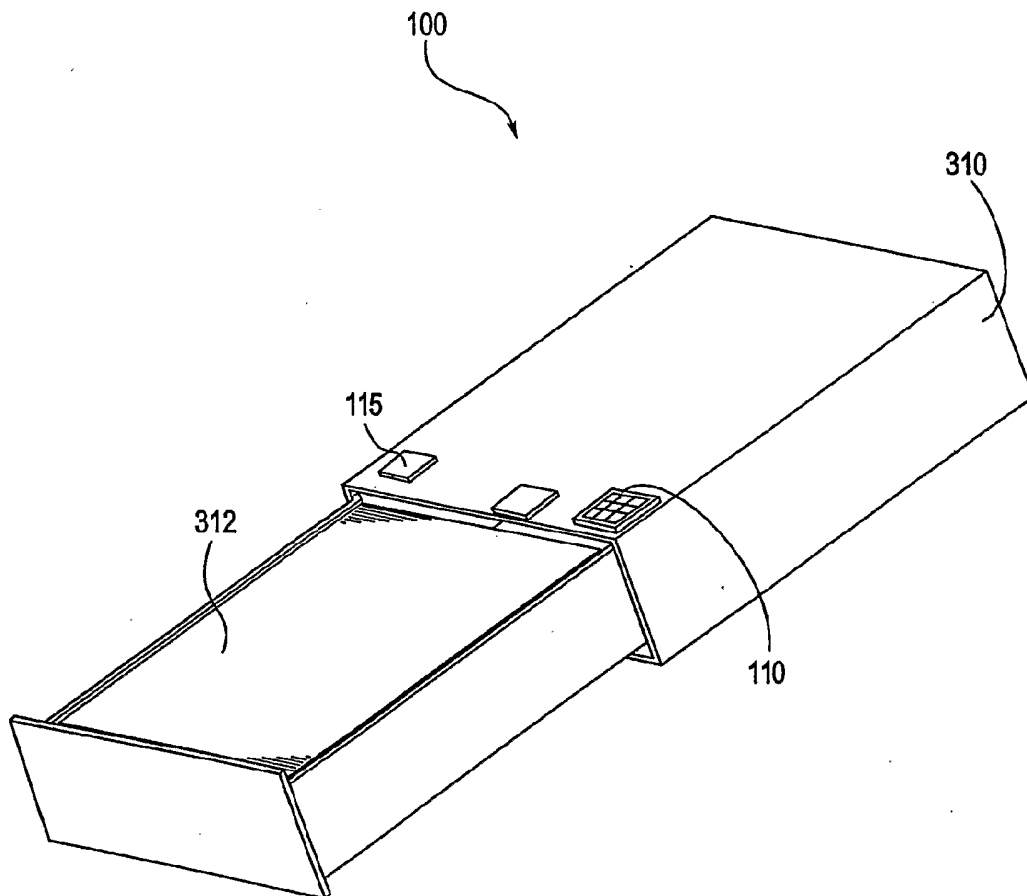

Fig. 3

4/27

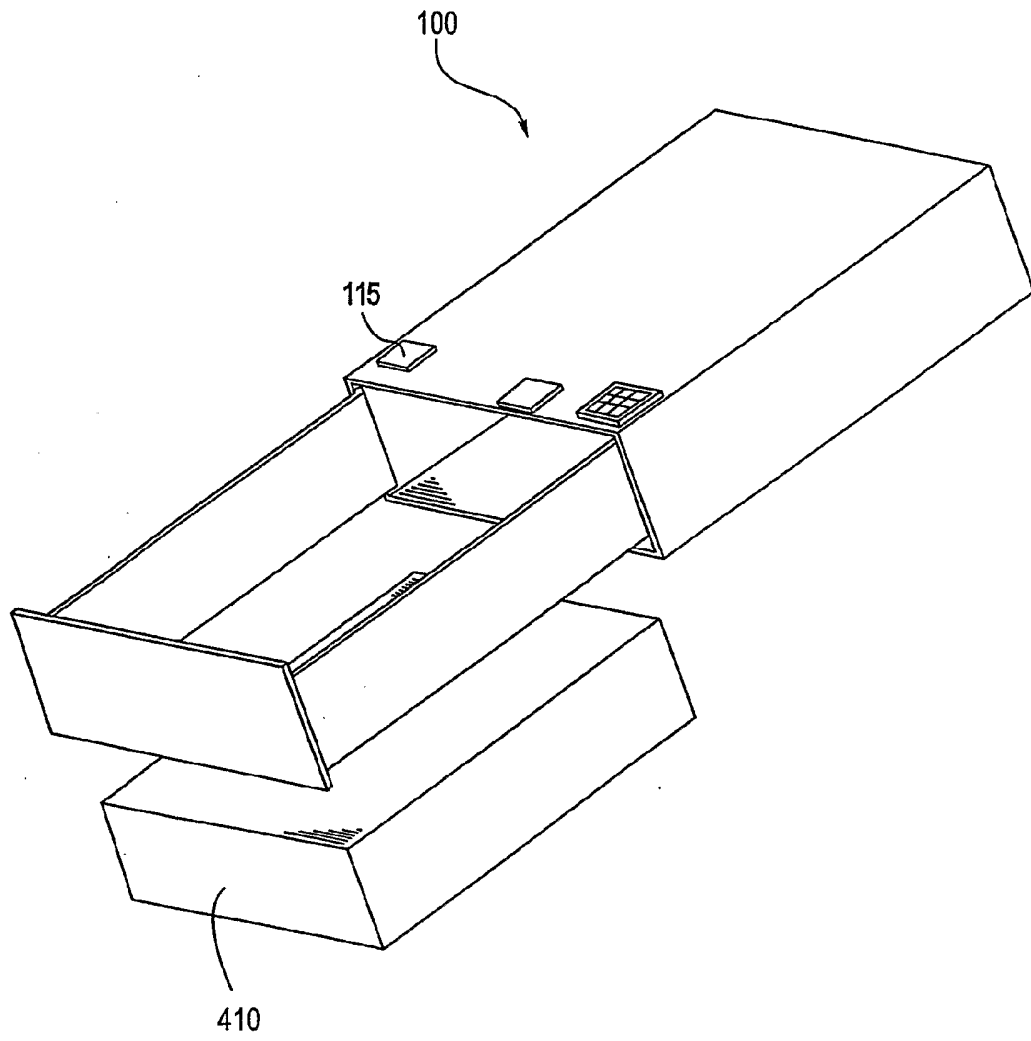

Fig. 4

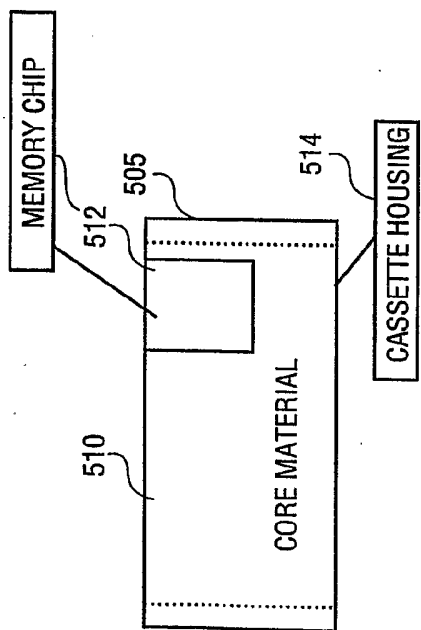

FIG. 5A

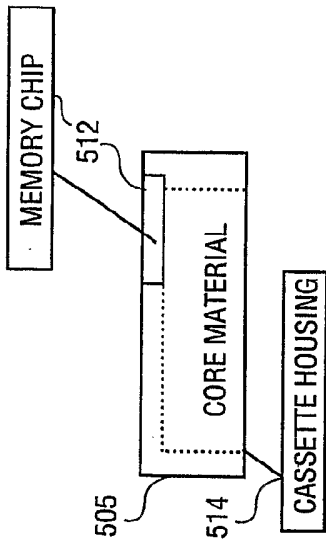
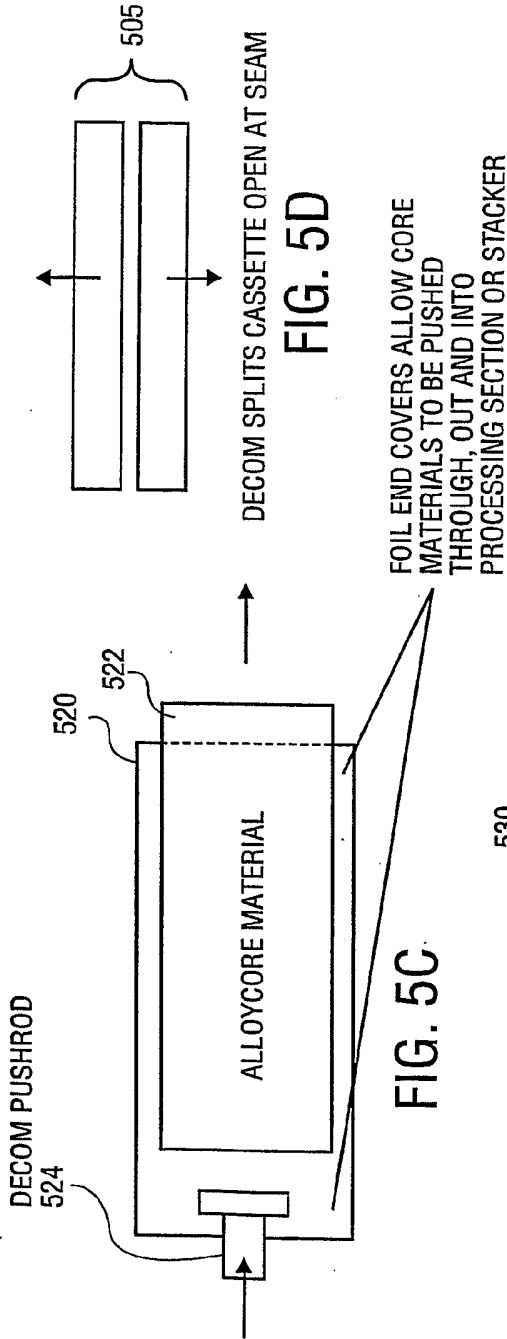

FIG. 5B



FOIL END COVERS ALLOW CORE MATERIALS TO BE PUSHED THROUGH, OUT AND INTO PROCESSING SECTION OR STACKER

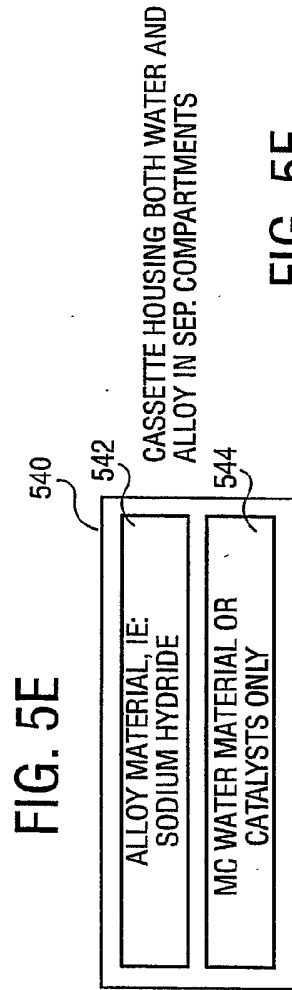
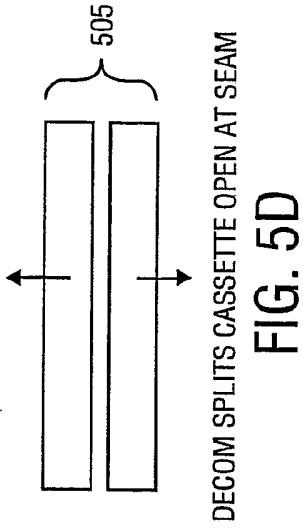

FIG. 5F

7/27

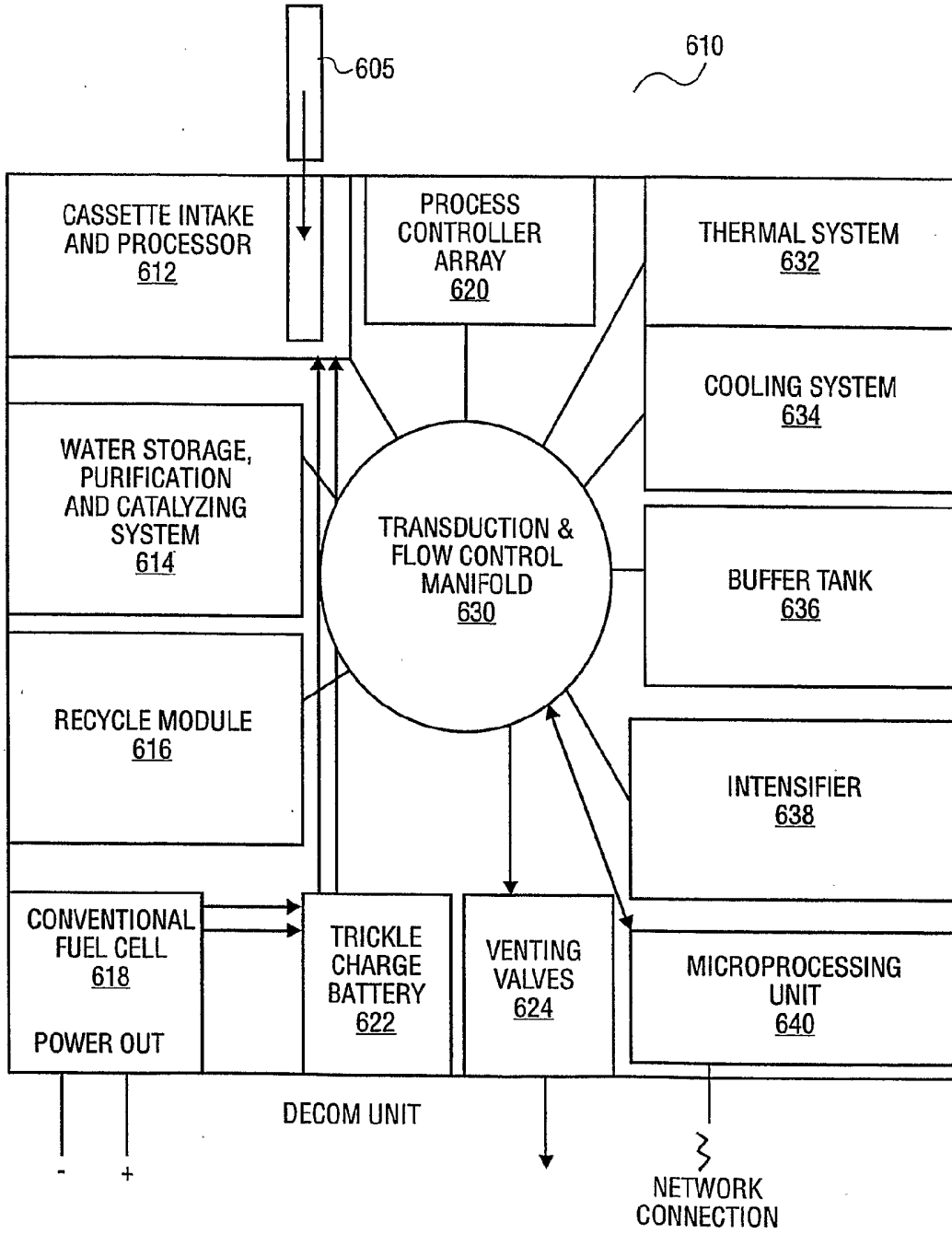
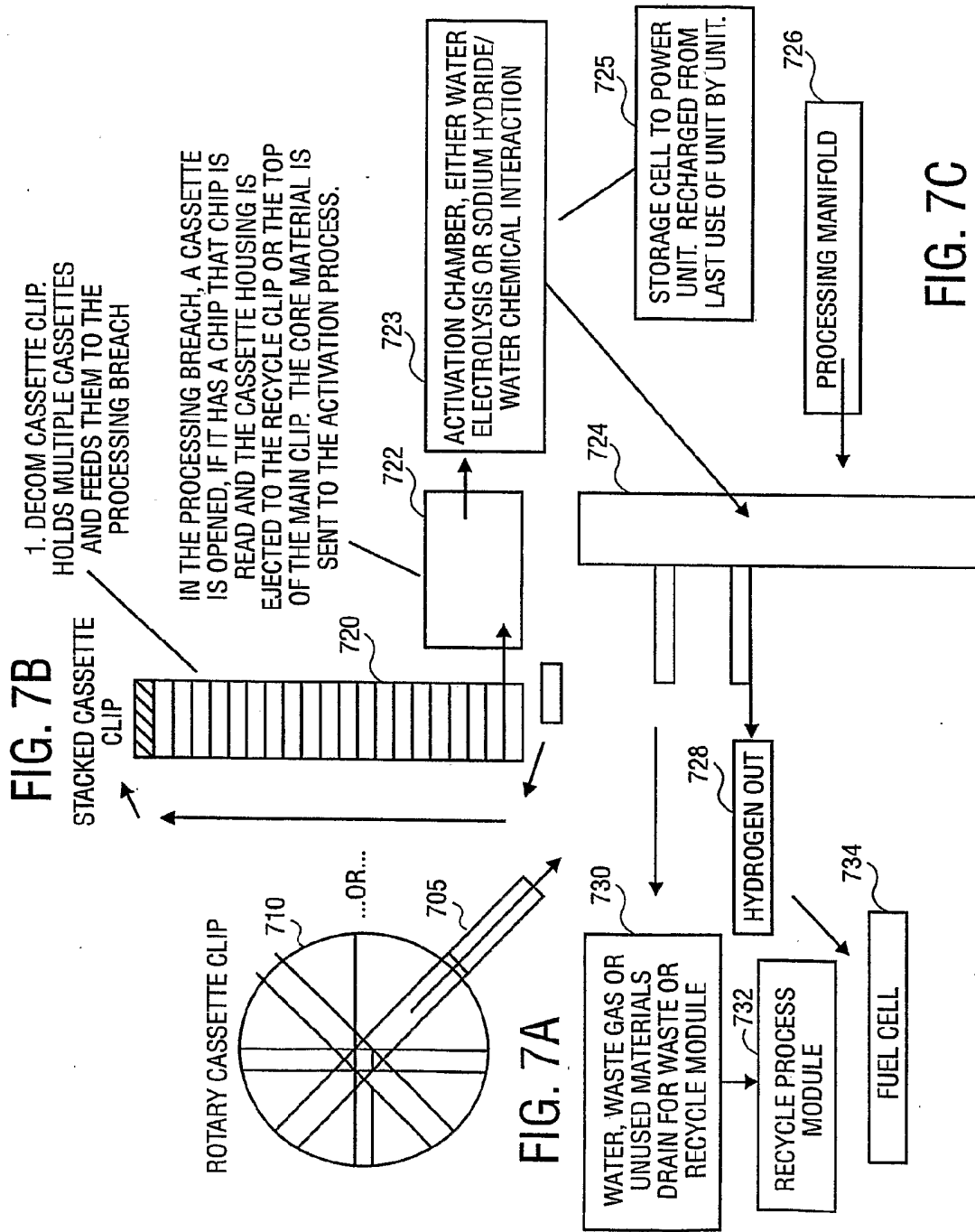

FIG. 6



9/27

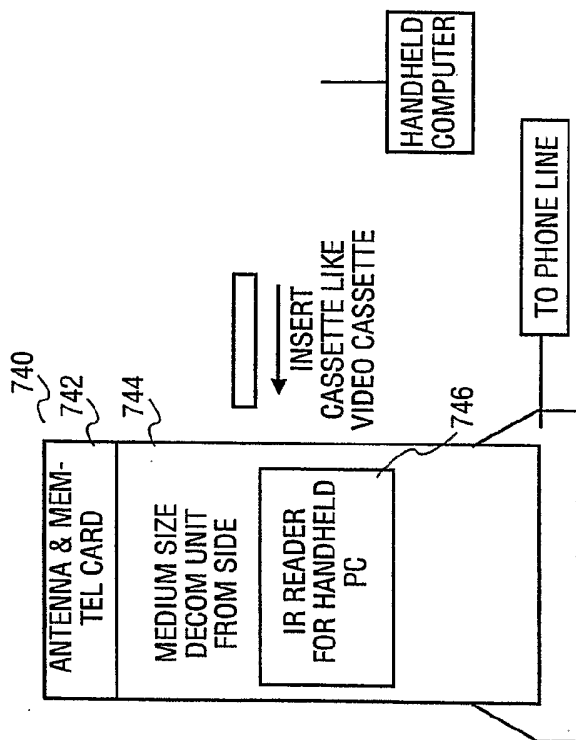

FIG. 7D

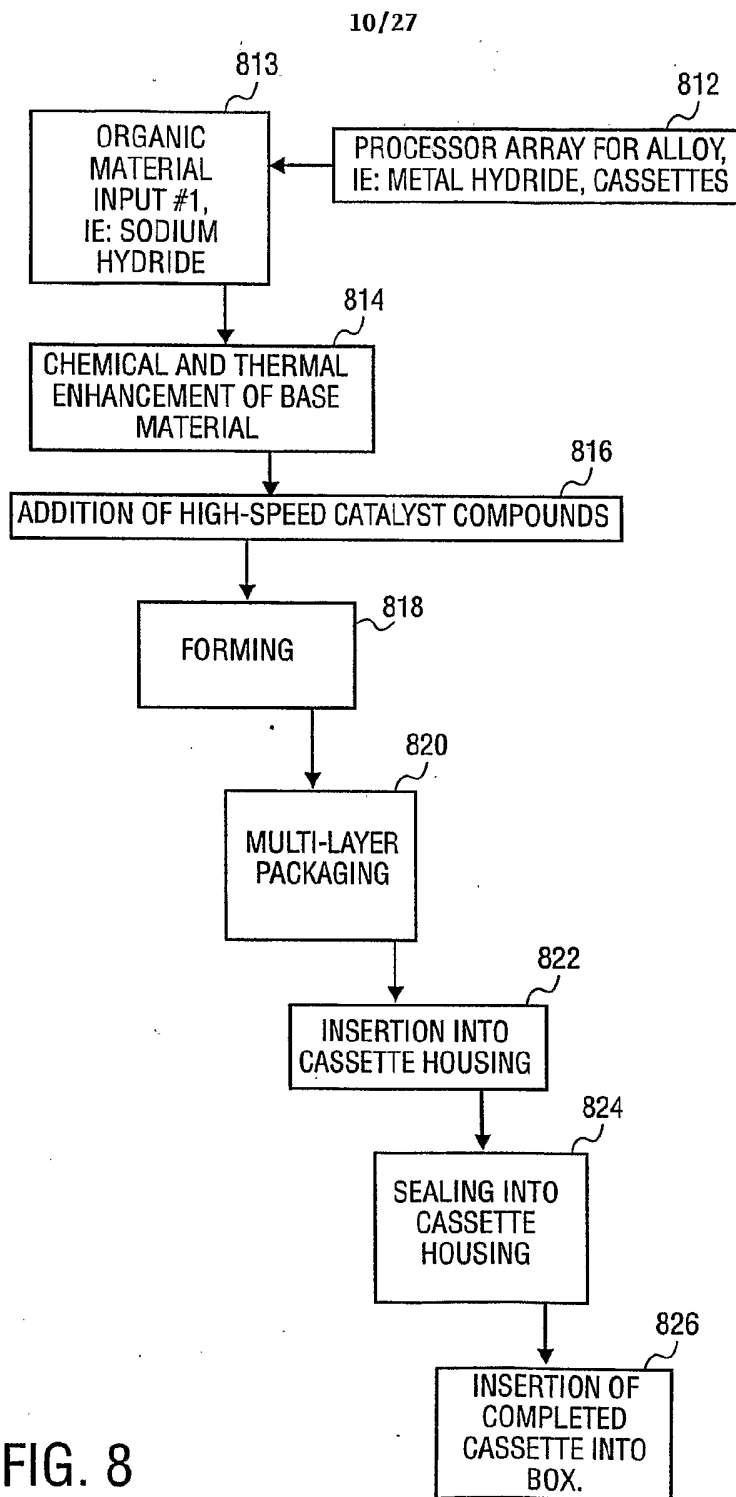

FIG. 8

11/27

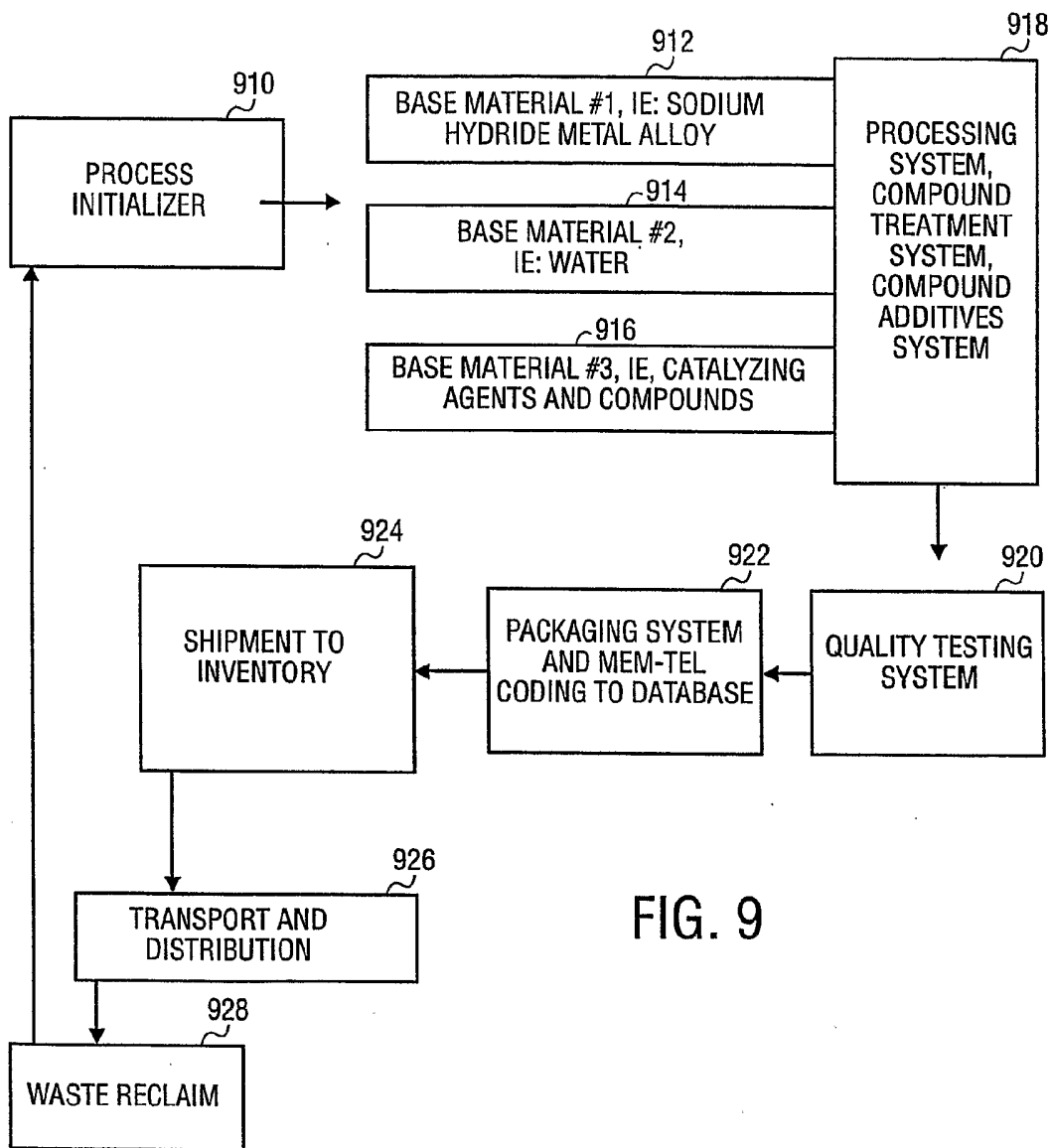

FIG. 9

12/27

THE VALUE OF WATER IS CLOSELY RELATED TO THE "BOND ANGLE" BETWEEN THE TWO HYDROGEN ATOMS IN THE WATER MOLECULE. OUR OZONATION OF WATER RESULTS IN A BOND ANGLE DEGREE IMPROVEMENT

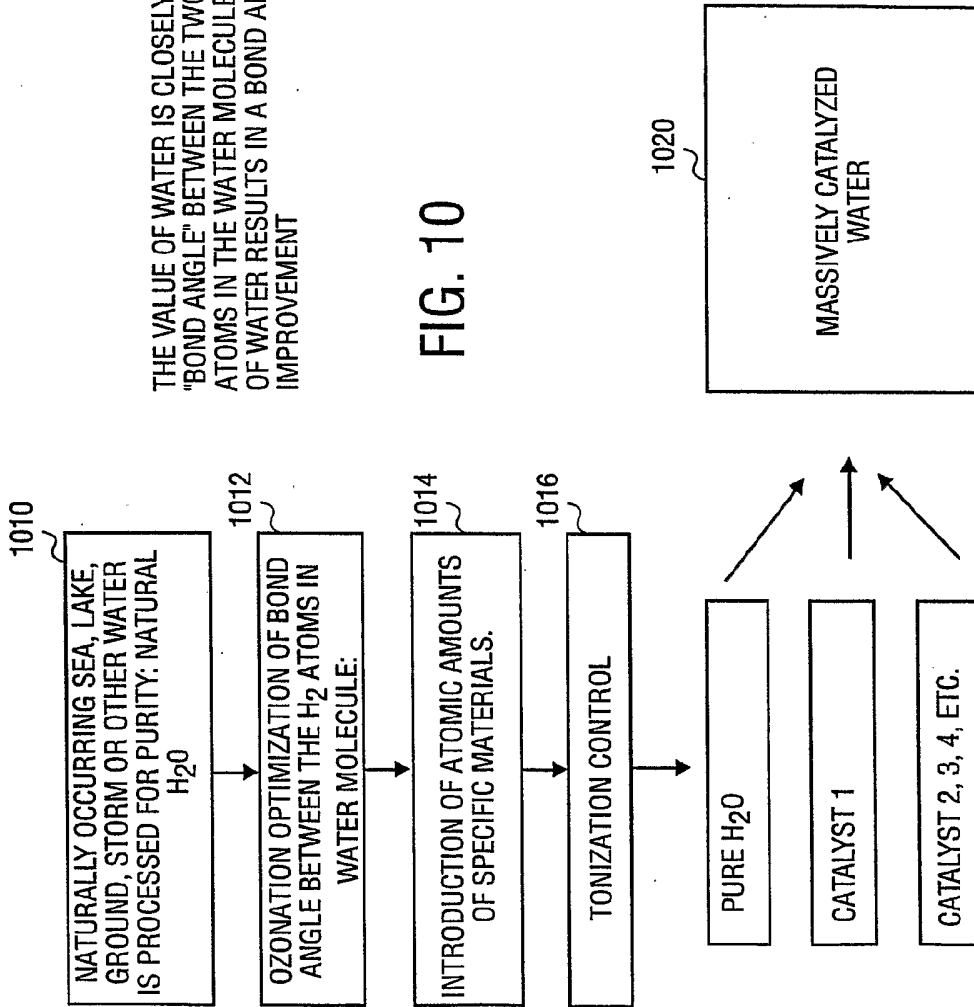

FIG. 10

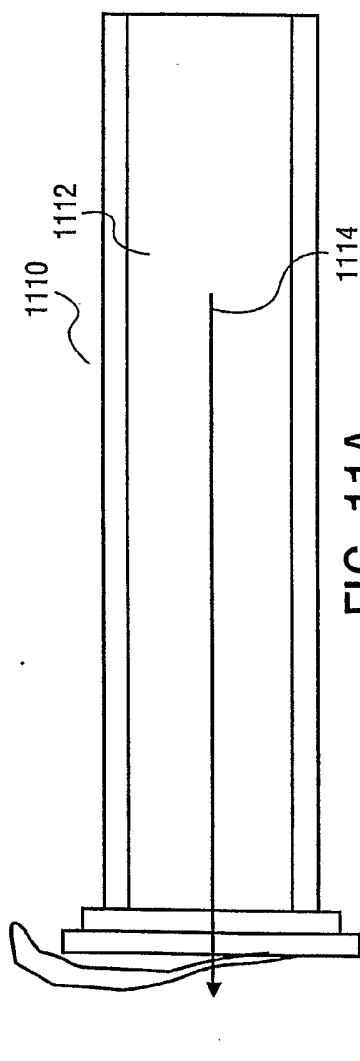

FIG. 11A

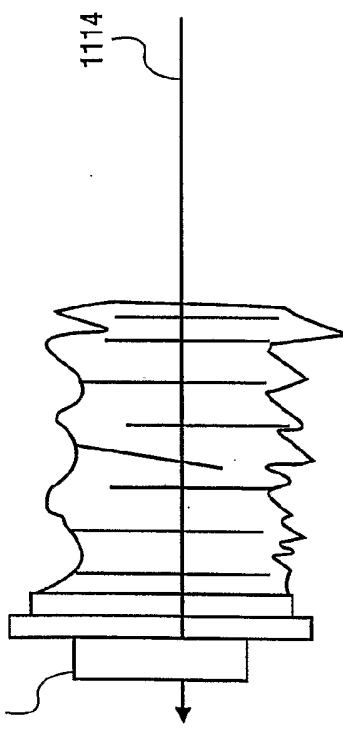

FIG. 11B

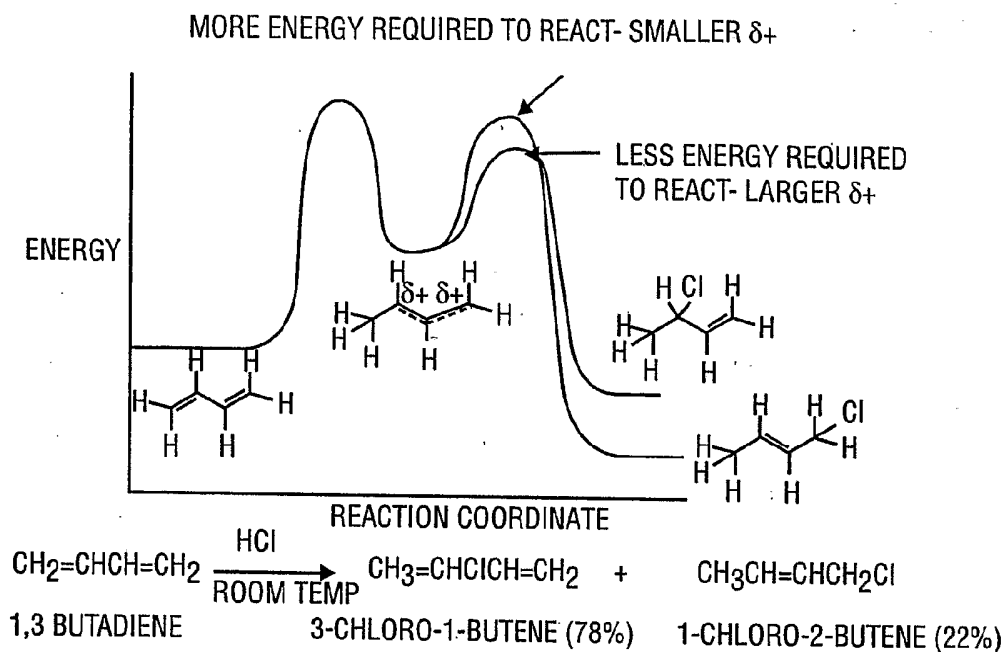

FIG. 12A

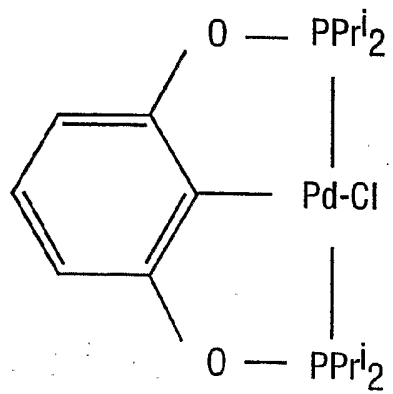
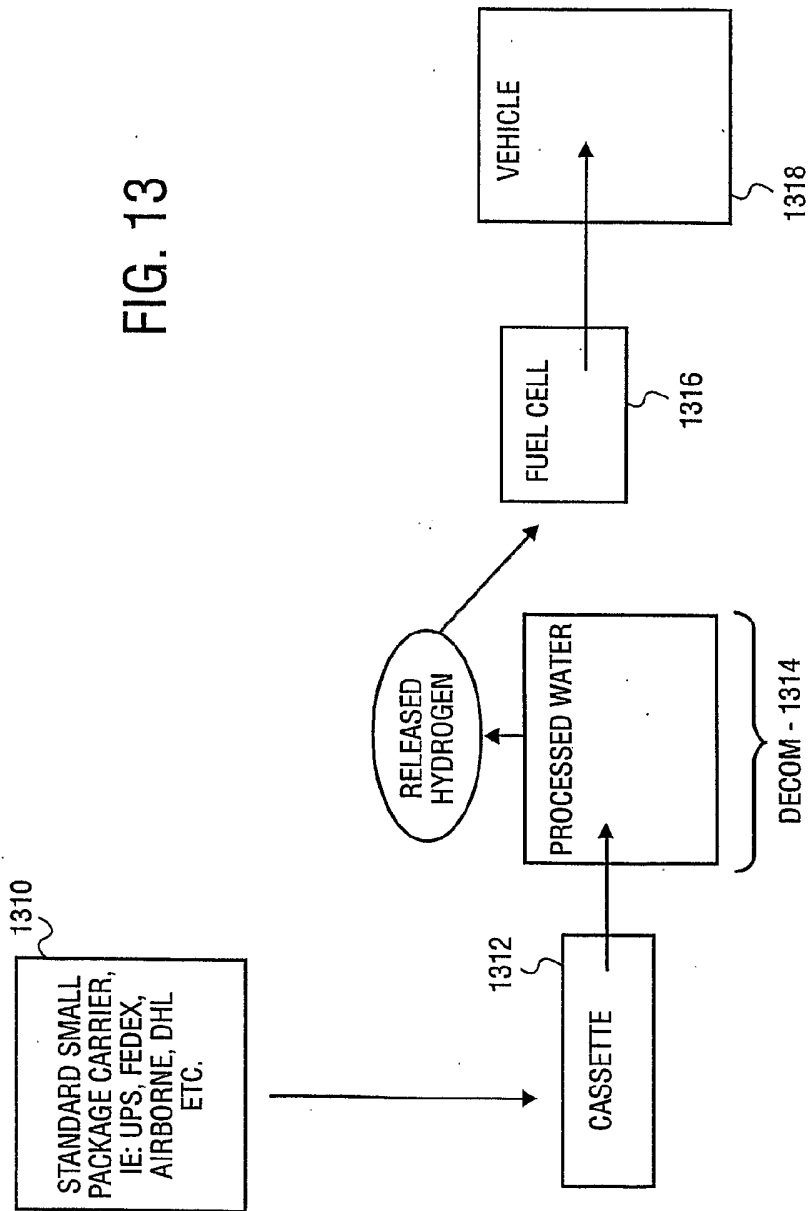

FIG. 12B

FIG. 13



16/27

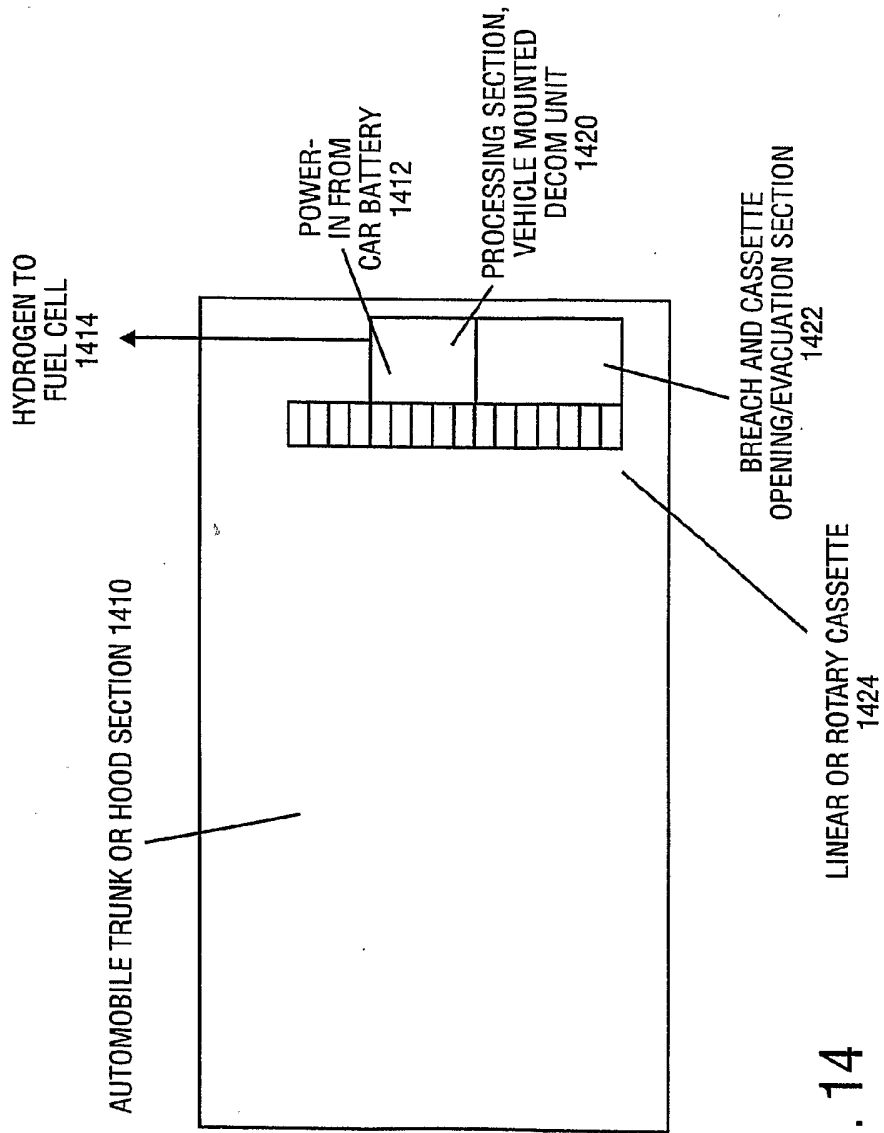

FIG. 14

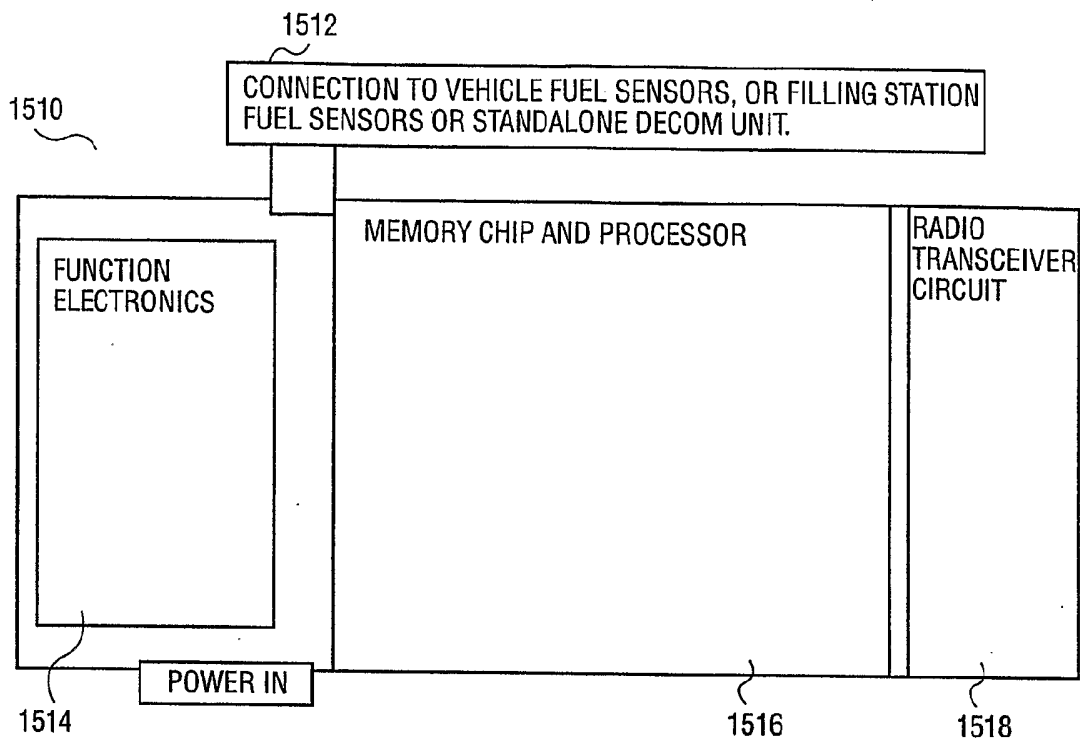

FIG. 15A

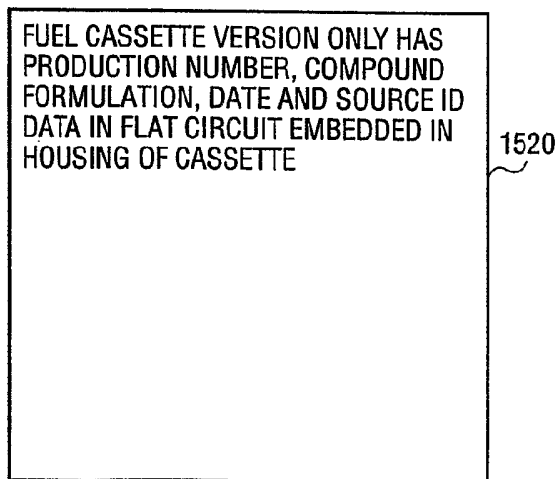

FIG. 15B

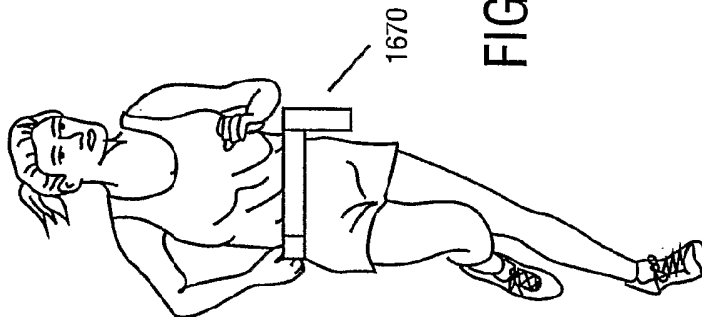

FIG. 16C

CASSETTE	1610		
DECOM	1612		
FUEL CELL	1614		
RECYCLE MODULE	1616	BATTERY	1618
CONTROL SYSTEM & MEM-TEL CIRCUIT		1620	

FIG. 16A

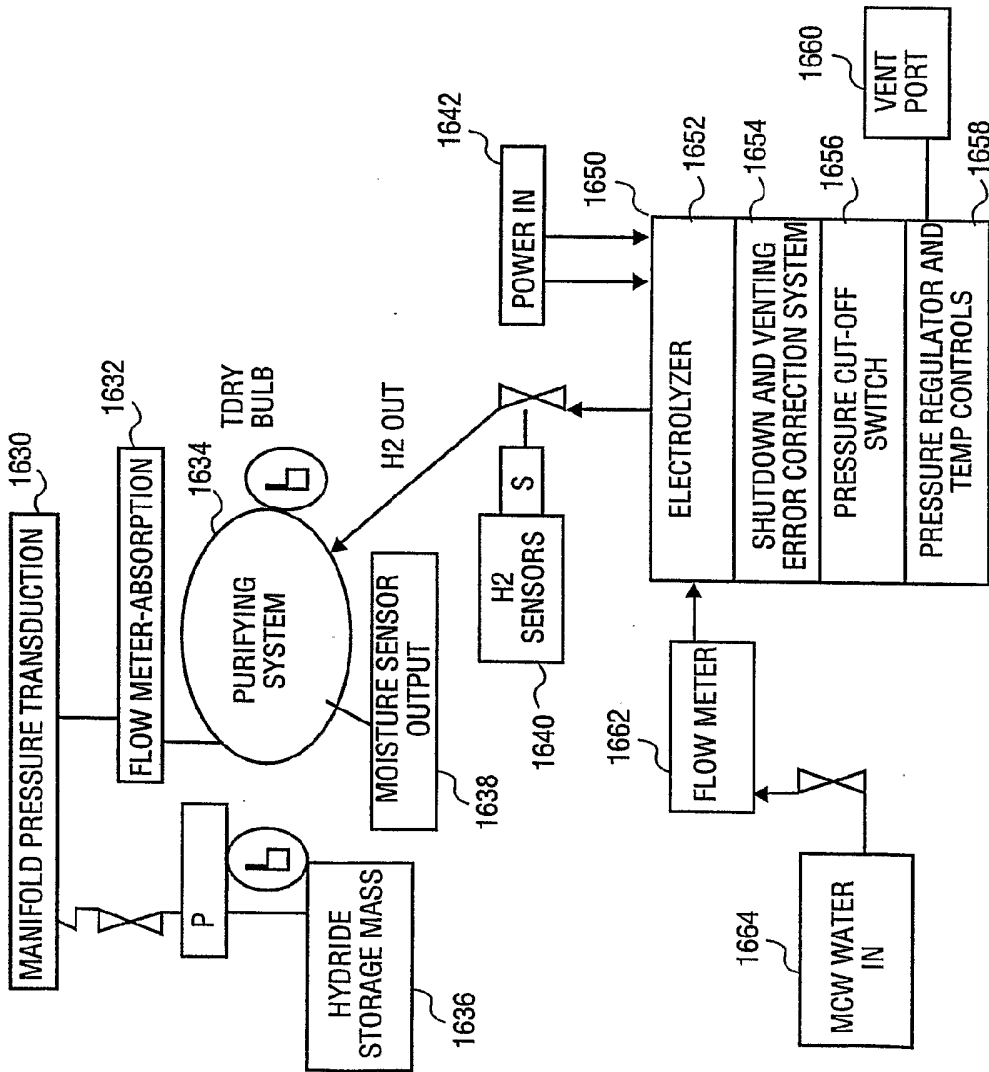

FIG. 16B

Figure 17

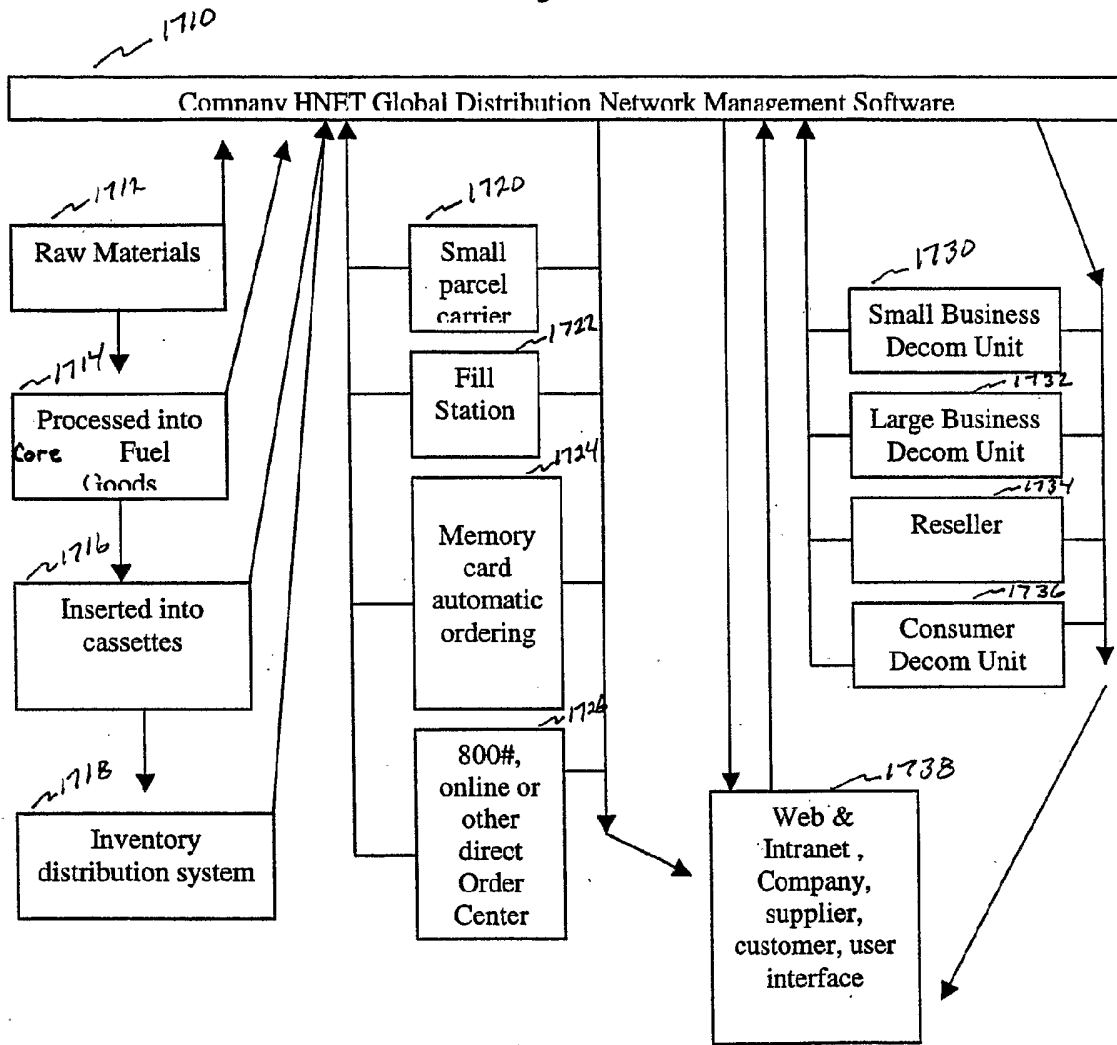
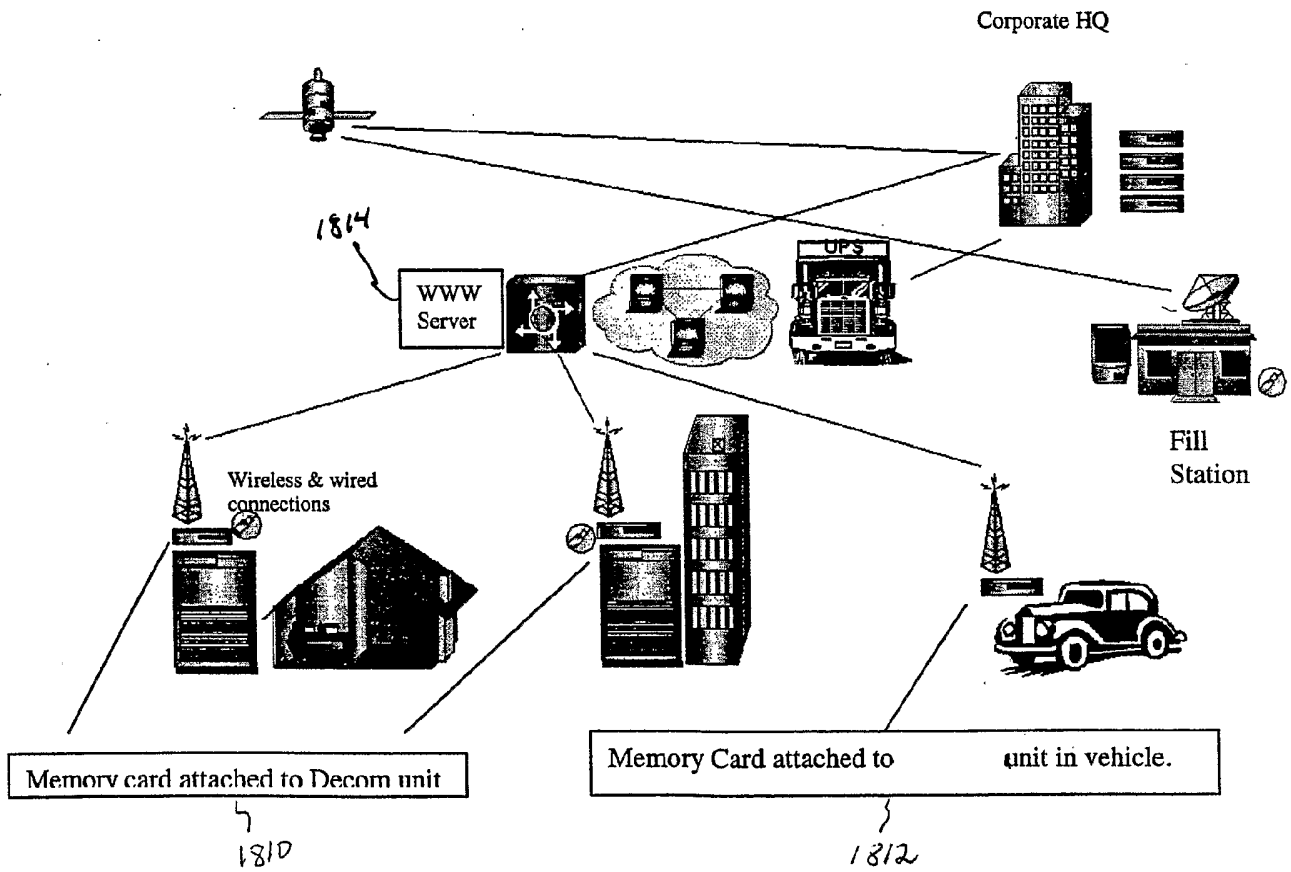

FIG. 18

Memory & Telemetry card communication & operations diagram



22/27

FIG. 19

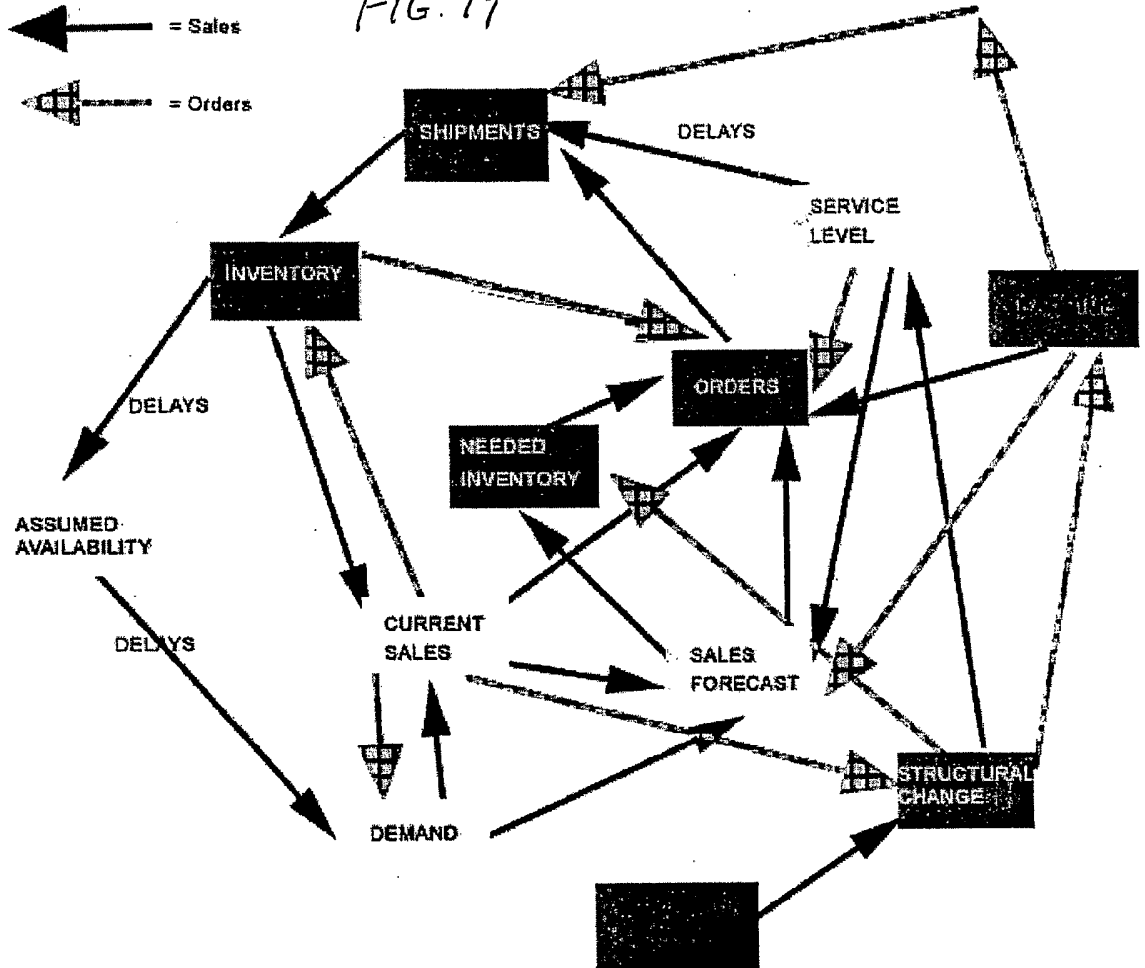

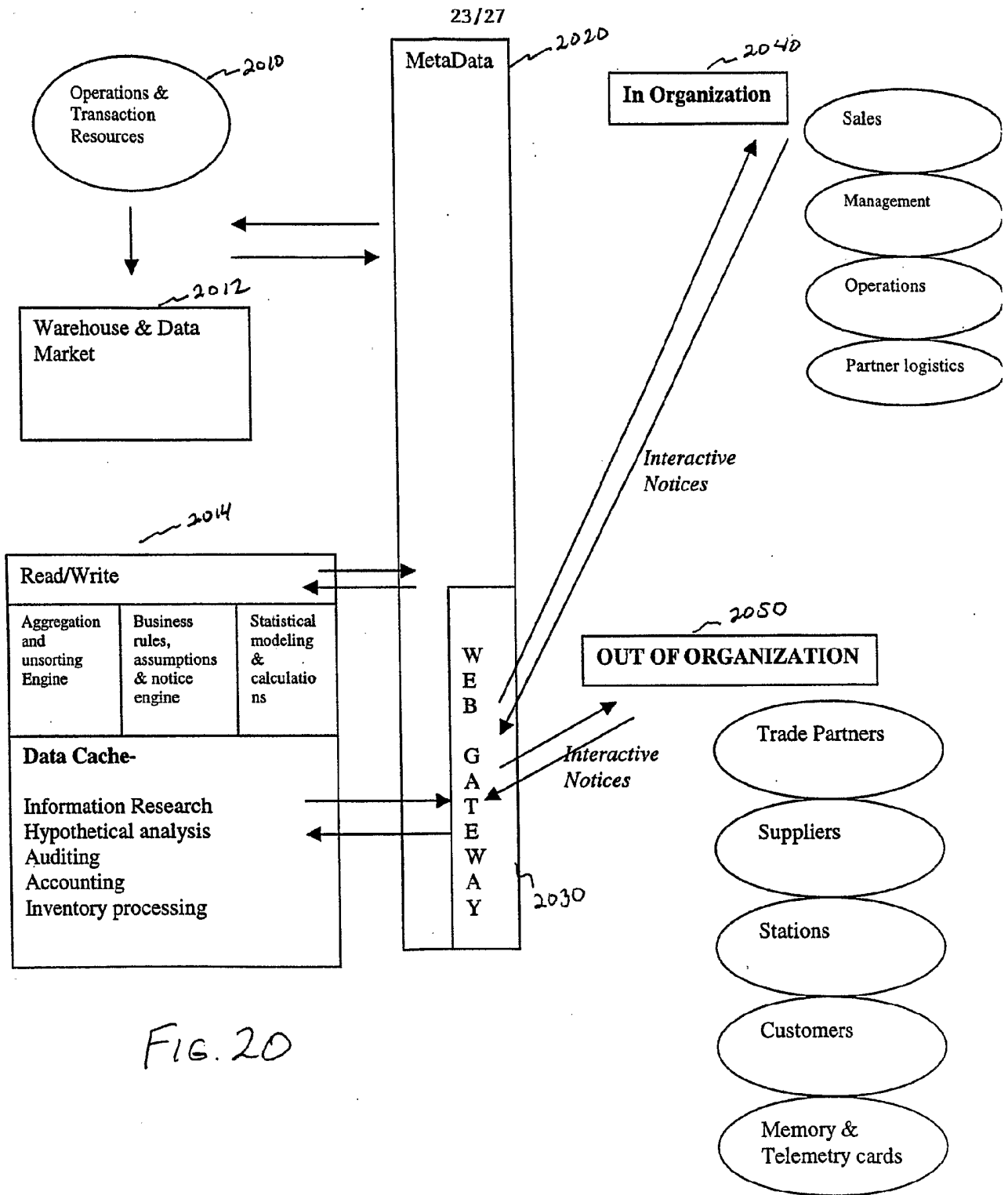
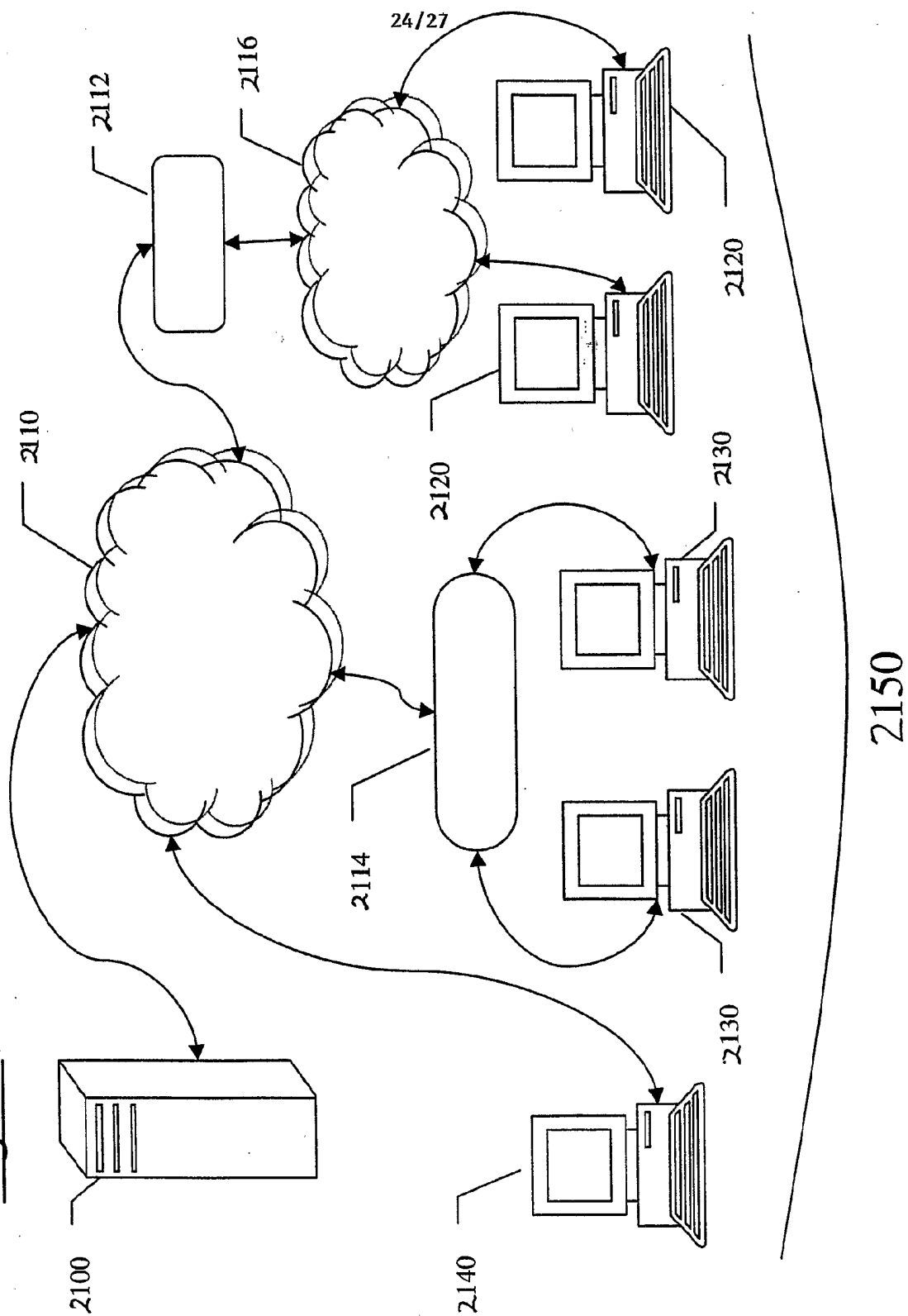

FIG. 20

Figure 21



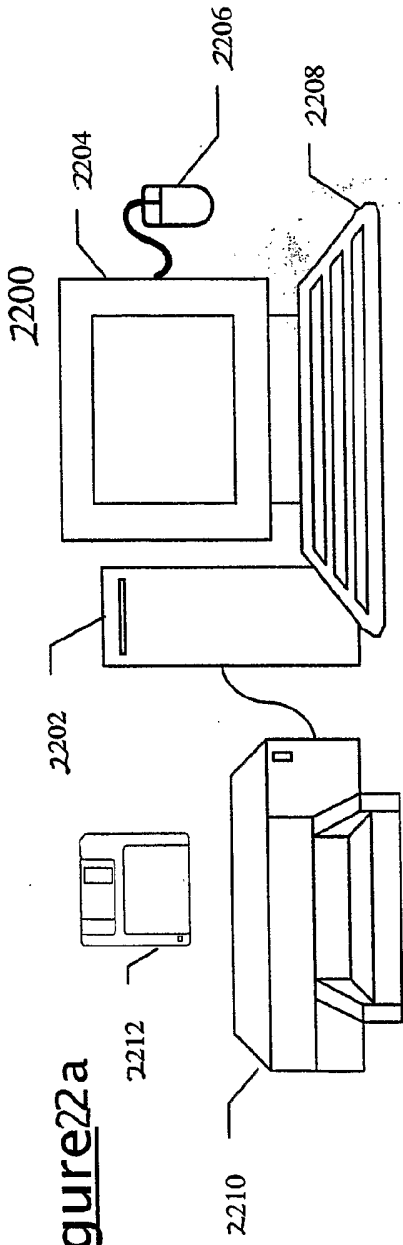

Figure 2200a

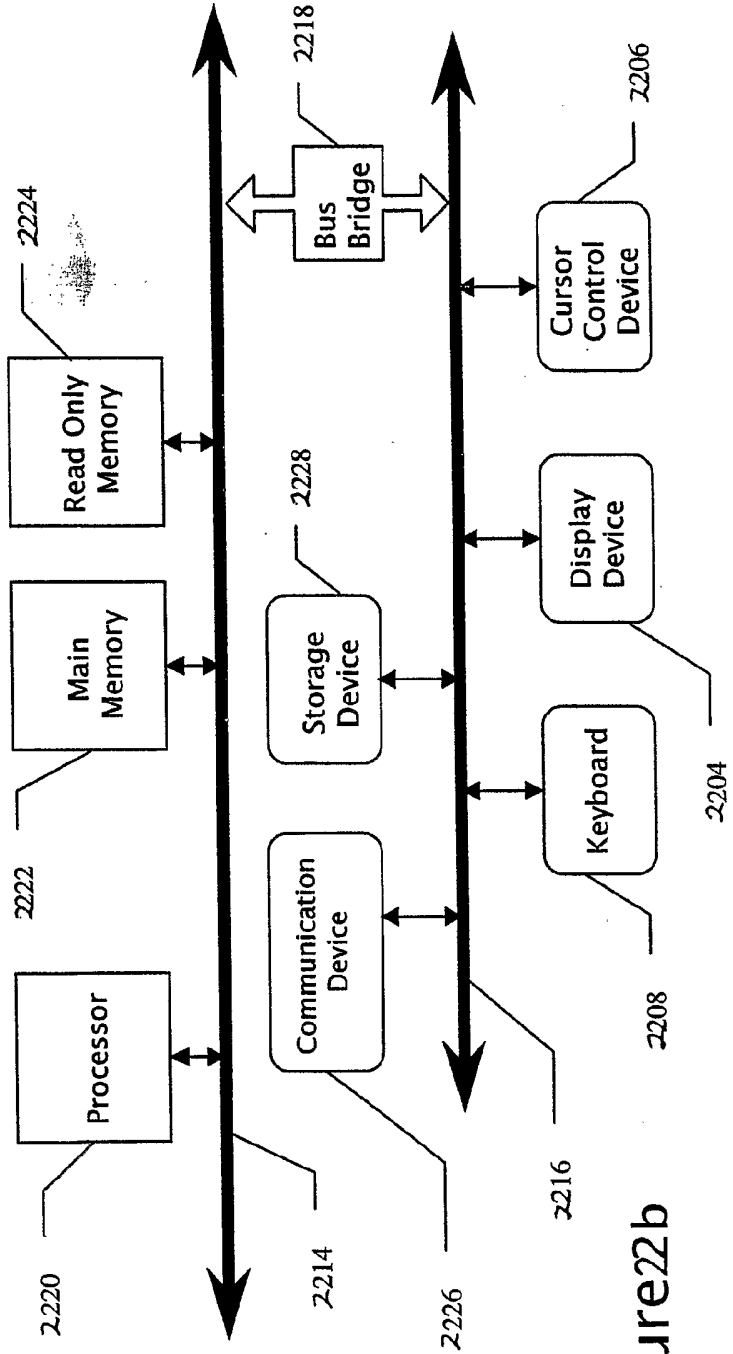

Figure 2200b

Address: D:\NOFS\User Sites\FuelSei...view\your_gateway.html

FuelSell Technologies

To LOG IN. Click your door, below

Welcome to the Smart-Fuel Gateway Demo. To login, please click your door and enter your password when prompted. Passwords are case-sensitive.

[Forgot Password?](#)

[About the ShareGrid Gateway](#)

[Registration](#)

[System Requirements](#)

[Industrial](#)

[Reseller](#)

[Consumer](#)

[H-Team](#)

[FST Home](#)

[My Settings](#)

[Help](#)

[Search](#)

[Sell Energy](#)

[Log Out](#)

Please contact our [Webmaster](#) with comments. © Copyright 2002 FuelSell Technologies. All rights reserved. Patents pending & licensed.

Done My Computer

FIG. 23

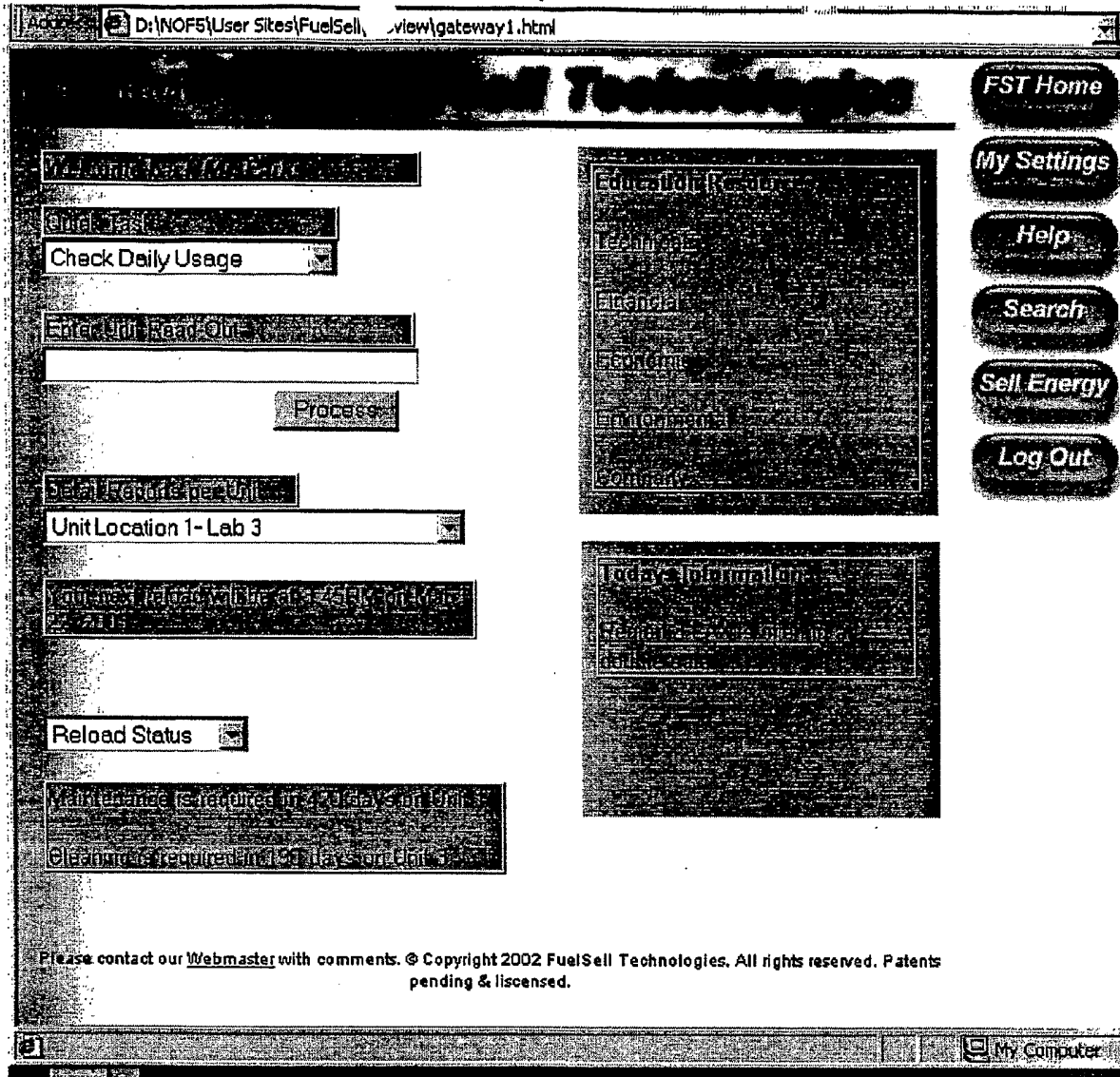

FIG. 24