

W. H. GEORGE.  
 GEARING FOR OPERATING WASHING MACHINES.  
 APPLICATION FILED OCT. 11, 1915.

1,220,838.

Patented Mar. 27, 1917.

2 SHEETS—SHEET 1.

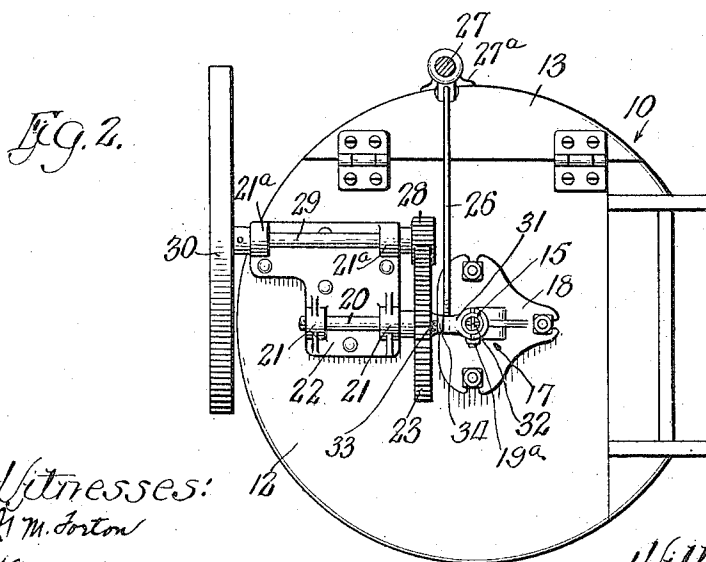
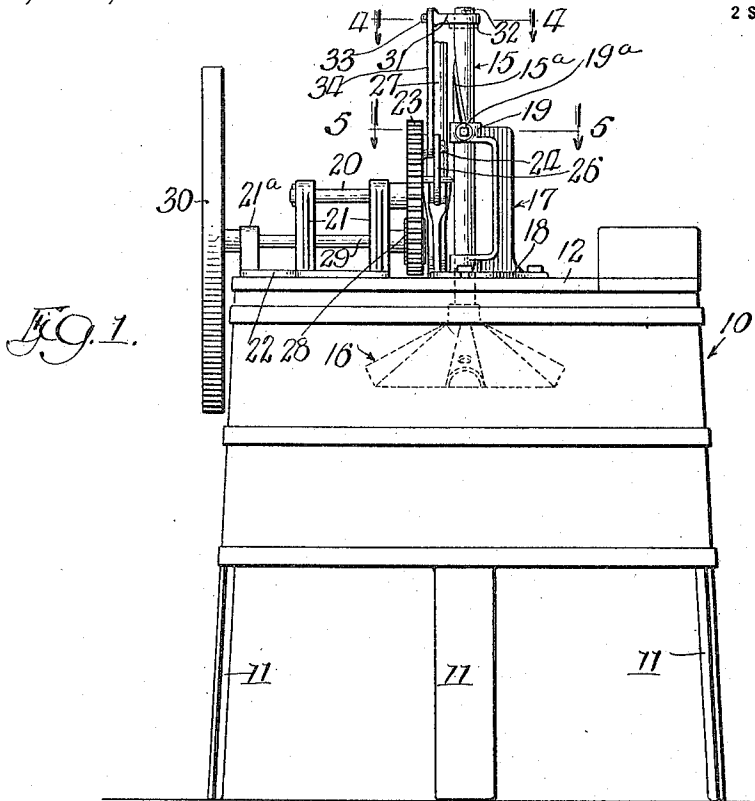

Witnesses:  
 R. M. Fortson  
 Karl W. Ball.

Inventor  
 William H. George  
 by Brown & Mehlhofer Attys

W. H. GEORGE.  
 GEARING FOR OPERATING WASHING MACHINES.  
 APPLICATION FILED OCT. 11, 1915.

1,220,838.

Patented Mar. 27, 1917.  
 2 SHEETS—SHEET 2.

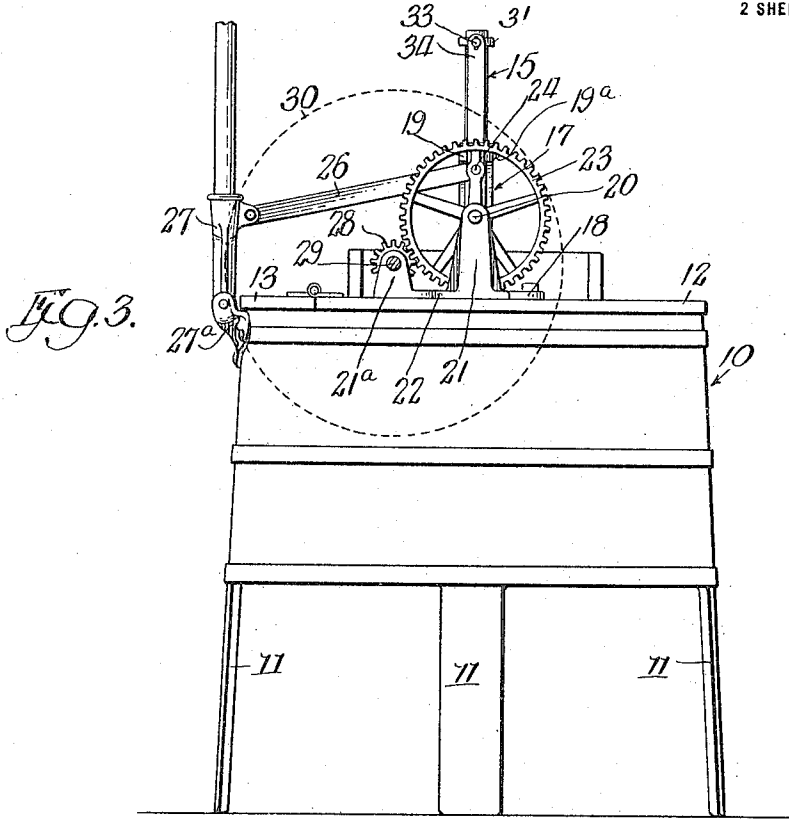

Fig. 3.

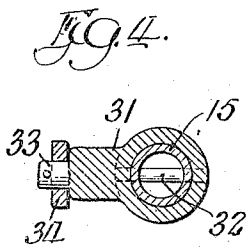

Fig. 4.

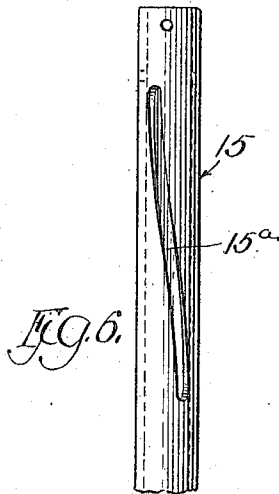

Fig. 6.

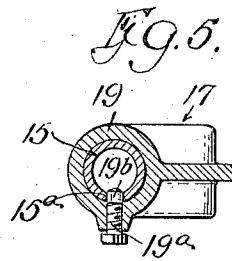

Fig. 5.

Witnesses:  
 H. M. Forton  
 Karl W. Doll

Inventor  
 William H. George  
 by Brown & Muhlhopf, Attys

# UNITED STATES PATENT OFFICE.

WILLIAM H. GEORGE, OF FAIRFIELD, IOWA, ASSIGNOR TO THE DEXTER COMPANY, OF FAIRFIELD, IOWA, A CORPORATION OF IOWA.

## GEARING FOR OPERATING WASHING-MACHINES.

1,220,838.

Specification of Letters Patent. Patented Mar. 27, 1917.

Application filed October 11, 1915. Serial No. 55,140.

### *To all whom it may concern:*

Be it known that I, WILLIAM H. GEORGE, a citizen of the United States, and a resident of Fairfield, in the county of Jefferson and State of Iowa, have invented certain new and useful Improvements in Gearing for Operating Washing-Machines; and I do hereby declare that the following is a full, clear, and exact description thereof, reference being had to the accompanying drawings, and to the letters of reference marked thereon, which form a part of this specification.

This invention relates to improvements in gearing for operating washing machines and the like and consists of the matters hereinafter described and more particularly pointed out in the appended claims.

The invention is herein illustrated as applied to drive the operating shaft of a washing machine of the vacuum, pounder type, which shaft is required to have both a longitudinal reciprocal movement and an alternating rotary movement. The object of the invention is to provide a simplified gearing of the kind described, comprising few parts which will impart the required movement to the operating shaft in a noiseless and efficient manner. The various advantages of my improved gearing will be apparent as I proceed with my specification.

In the drawings:—

Figure 1 is a view in front elevation of a washing machine of the type above mentioned, embodying my improved operating mechanism.

Fig. 2 is a view thereof in top plan elevation.

Fig. 3 is a view in side elevation thereof as looked at toward the fly-wheel, the same being illustrated in dotted lines.

Fig. 4 is a detail horizontal sectional view on an enlarged scale, the plane of the section being indicated by the line 4—4 of Fig. 1.

Fig. 5 is a similar view, the plane of the section being indicated by the line 5—5 of Fig. 1.

Fig. 6 is a detail view in elevation of a part of the operating shaft and will be more particularly referred to later.

Referring now in detail to that embodiment of my invention illustrated in the accompanying drawings:—10 indicates a support which in this case is an ordinary washing machine tub having the usual upright

supporting legs 11. Said tub has a lid 12 which is hinged to the stationary top wall 13 of the tub in the usual way.

15 indicates the upright operating shaft of the washing machine. As has been said, the gearing is designed to impart both a longitudinal, reciprocal and rotary, alternating movement to the said shaft. The shaft 15 is preferably tubular in cross section and depends through the hinged lid 12 into the interior of the tub body, wherein it has fixed to its lower end a pounder 16 of a well known type, as shown in dotted lines in Fig. 1. The shaft 15 is suitably mounted in a bracket 17 having an apertured base plate 18 attached to the tub lid and an overhanging bearing sleeve 19 spaced above said base. A pin or screw 19<sup>a</sup> fixed radially in the bearing sleeve 19 engages in a long spiral cam slot 15<sup>a</sup> in the upper length of the operating shaft 15, (see Figs. 1, 5 and 6), an antifriction roller 19<sup>b</sup> being preferably mounted on the engaging part of the pin. The slot 15<sup>a</sup> is of a vertical length sufficient to permit the operating shaft to travel the full length of its longitudinal reciprocal movement and is of an arcuate length determined by the angle through which the operating shaft is to be rotated before it is reversed, in its alternating, rotary movement.

Movement is imparted to the shaft 15 as follows: In a vertical plane with the shaft 15 extending as shown parallel to the hinge line of the tub lid 12, is mounted a horizontal shaft 20, the inner end of which terminates near the shaft 15. Bearing for the shaft 20 is provided in upright standards 21, 21, rising from a base plate 22, fixed to the lid 12. A large gear 23 is fixed to the inner end of the shaft 20 and a crank pin 24, on said gear, is operatively connected to an upright hand lever 27 fulcrumed upon the tub body 10, near the fixed top 13. The fulcrum is provided by a bracket plate 27<sup>a</sup> fixed to the tub. The lever 27 swings in a vertical plane parallel to the plane of the gear 23, that is to say, in a plane that extends at right angles to the shaft 20.

A horizontal shaft 29, spaced from and extending parallel to the shaft 20 (being intermediate the shaft 20 and the hinge line of the lid 12,) is mounted in short bearing standards 21<sup>a</sup>, 21<sup>a</sup>, rising from the base plate 22. The outer end of the shaft 29 extends shortly beyond the tub where it has

fixed to it a fly wheel 30. The inner end of said shaft has fixed to it a pinion 28 which is engaged by the large gear 23. It will be apparent from the foregoing description that an oscillating movement of the hand lever 27 will impart a continuous rotary movement at high speed to the fly-wheel 30, the momentum of which will facilitate the operation of the gearing in a familiar manner.

The gear 23 is operatively connected with the shaft 15 as follows: 31 indicates a short, horizontal, radially extending arm rotatively mounted upon the shaft 15 in a position near its top. (See Figs. 1 and 4). Said arm is secured against displacement lengthwise of the shaft by any suitable means,—as shown, by pins 32, 32 fixed in the shaft above and below said arm 31. The arm 31 has a reduced end 33, (see Fig. 4) which is operatively connected by a link 34, to the crank pin 24 on the gear 23.

The continuous rotary movement imparted to the gear 23 in either direction by the operating lever 27, as heretofore described, will, through the crank pin 24, link 34 and arm 31, impart a vertical reciprocatory movement to the shaft 15. By reason of the engagement of the pin 19<sup>a</sup> of the fixed bearing sleeve 19, with the spiral slot 15<sup>a</sup> in the operating shaft, said shaft will at the same time, have imparted to it an alternating, rotary movement of an amplitude determined by the arcuate length of the said slot, this movement being permitted by the rotative play of the arm 31 upon the shaft 15.

It will be manifest from the foregoing description and from a consideration of the drawings illustrating the preferred form of my invention, that the driving force applied to the prime moving lever 27 is applied in a plane closely adjacent to the operating shaft 15, and its connection with said shaft includes but a minimum of parts that intervene between the application of the force and the member to be operated.

This effects a positive and forcible operation of the shaft 15 with a minimum of lost motion so that the shaft is quickly reversed when it reaches the limits of its combined movement. As a consequence, when the gearing is applied to washing machines, the operating shaft will produce quicker and better work in the washing of clothes.

Another advantage of the improved gearing is that it is possible to assemble it on the movable or hinged member of the support, namely, the tub lid, with the prime moving lever working in a plane at right angles to the hinge line and substantially midway between the hinges, thus obviating the twisting strain on the lid, that is produced by prior gearings of the kind.

While in describing my invention, I have referred to certain details of mechanical

construction and arrangement, it is to be understood that the invention is in no way to be limited thereby except as may be pointed out in the appended claims.

I claim as my invention:—

1. A gearing of the kind described, comprising in combination with an operating shaft capable of both a vertical, reciprocating movement and of an alternating, rotary movement, a device engaged with said shaft for imparting an alternating, rotary movement to said shaft when it is reciprocated vertically, a prime moving lever, means intermediate said prime moving lever and said shaft for vertically reciprocating said shaft, said means including a gear adapted to be continuously rotated by said prime moving lever, said lever operating in a plane between said upright shaft and said gear and a fly-wheel operatively connected to said gear and rotated thereby.

2. A gearing of the kind described, comprising in combination with an operating shaft capable of both a vertical, reciprocating movement and of an alternating, rotary movement, means providing a bearing for said shaft, means intermediate said bearing and said shaft for imparting an alternating, rotary movement to said shaft when it is reciprocated vertically, a prime moving lever operating in a vertical plane closely adjacent to the vertical plane of said operating shaft, a large gear in substantially the plane of said prime moving lever, a link operatively connecting said prime moving lever with said large gear, means connecting said large gear with said operating shaft, adapted to transpose the continuous rotating movement of said large gear into a vertical, reciprocating movement of said operating shaft, a fly wheel and gearing intermediate said large gear and said fly wheel.

3. A gearing of the kind described, comprising in combination with a support, a hinged member carried by said support, an operating shaft capable of both a vertical, reciprocating movement and of an alternating, rotary movement, means carried by said hinged member providing a bearing for said shaft, a device engaged with said shaft for imparting an alternating, rotary movement to said shaft when it is reciprocated vertically, a prime moving lever, means intermediate said prime moving lever and said shaft for vertically reciprocating said shaft, a gear adapted to be continuously rotated by said prime moving lever, said lever operating in a plane between said upright shaft and said gear and a fly-wheel operatively connected to said gear and rotatively driven thereby.

4. A gearing of the kind described, comprising in combination with an operating shaft capable of both a vertical, reciprocating movement and of an alternating, rotary

movement, means providing a bearing for said shaft, means intermediate said bearing and said shaft for imparting an alternating, rotary movement to said shaft when it is reciprocated vertically, a prime moving member operating in a median plane of said hinged member extending at right angles to the hinge line of said member and closely adjacent to said operating shaft, a large gear in substantially the plane of said prime moving lever, a link operatively connecting said prime moving lever with said large gear, means connecting said large gear with said operating shaft, adapted to transpose the continuous rotating movement of said large gear into a vertical, reciprocating movement of said operating shaft, a fly wheel and gearing intermediate said large gear and said fly wheel.

5. A gearing of the kind described, comprising in combination with an operating shaft capable of both a vertical, reciprocating movement and of an alternating, rotary movement, means providing a bearing for said shaft, a device on said bearing engaged with said shaft adapted to impart an alternating, rotary movement to said shaft when the shaft is reciprocated vertically, a prime moving lever, a large gear located closely adjacent to said operating shaft, a pitman connecting said gear with said lever, a rotative arm on said operating shaft, a pitman connecting said arm with said large

gear, a fly wheel, and means connecting said large gear with said fly wheel.

6. A gearing of the kind described, comprising in combination with an upright operating shaft having an elongated spiral cam slot, said shaft being capable of both a vertical reciprocating movement and an alternating rotary movement, means providing bearing sleeves for said shaft, a device fixed to one of said sleeves and projecting into said cam slot and acting to impart an alternating rotary movement to said shaft, when said shaft is reciprocated vertically, an arm pivotally mounted on said operating shaft and capable of a swinging movement in a horizontal plane, a prime moving lever operating in a plane closely adjacent to the plane of said shaft, a large gear having a crank arm, adapted to be continuously rotated by said prime moving lever, a link connecting said crank arm and the arm on said operating shaft, and a fly wheel, said fly wheel being adapted to be driven by said large gear at high speed.

In testimony that I claim the foregoing as my invention I affix my signature in the presence of two witnesses, this 24th day of September, A. D. 1915.

WILLIAM H. GEORGE.

Witnesses:

H. R. MURRAY,  
R. D. HUNT.