

[54] **MEDICAL DEVICES**

[76] **Inventor:** Abraham Dov Merav, 5800
 Arlington Ave., Riverdale, N.Y.
 10471

[22] **Filed:** Aug. 26, 1970

[21] **Appl. No.:** 67,123

[52] **U.S. Cl.**..... 128/351, 128/245

[51] **Int. Cl.**..... A61m 25/00

[58] **Field of Search**..... 128/348, 351, 245,
 128/208

[56] **References Cited**

UNITED STATES PATENTS

3,709,227	1/1973	Hayward.....	128/351
3,616,799	11/1971	Sparks.....	128/351
3,592,183	7/1971	Watkins et al.....	128/1 R
3,592,184	7/1971	Watkins et al.....	128/1 R
3,565,079	2/1971	Jackson.....	128/351
724,913	4/1903	Montgomery.....	128/245
2,442,573	6/1948	Stafford.....	128/245
3,460,541	8/1969	Doherty.....	128/351

FOREIGN PATENTS OR APPLICATIONS

1,166,977 4/1964 Germany..... 128/351

Primary Examiner—Dalton L. Truluck

Attorney—Murray Schaffer

[57] **ABSTRACT**

Apparatus for intubation within body passages, comprising an elongated tube having the usual opening at the distal end and means for connection to a source of fluid, such as air, at the other end. Occlusion means is located about the surface of the tube near the open end to seal the space between the passage and the tube against flow of air. The occlusion means comprises a bag or canopy secured at its center, to the outer surface of the tube and terminating in a free edge directed toward the distal end being substantially open for receipt of air from the direction of the open end of said tube. The canopy is adapted to be distended against the inner surface of the passage to form the required seal.

9 Claims, 8 Drawing Figures

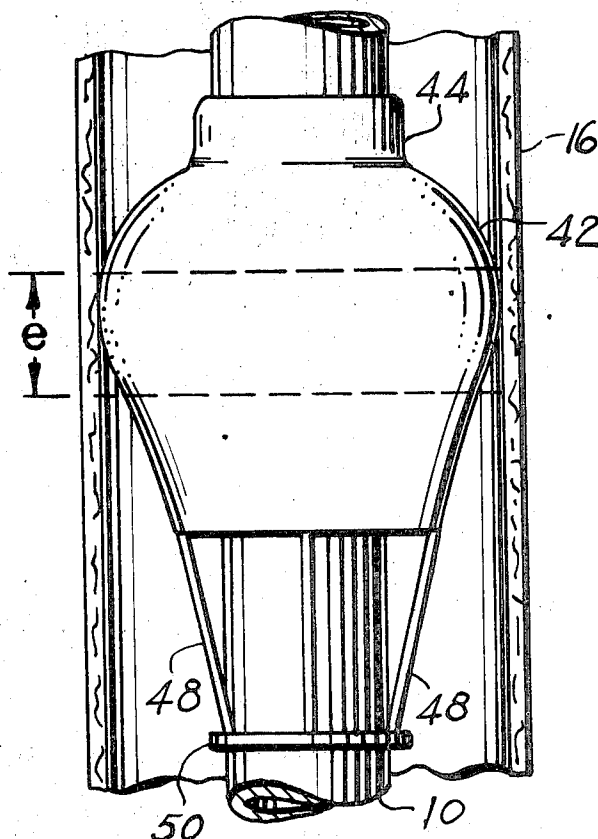

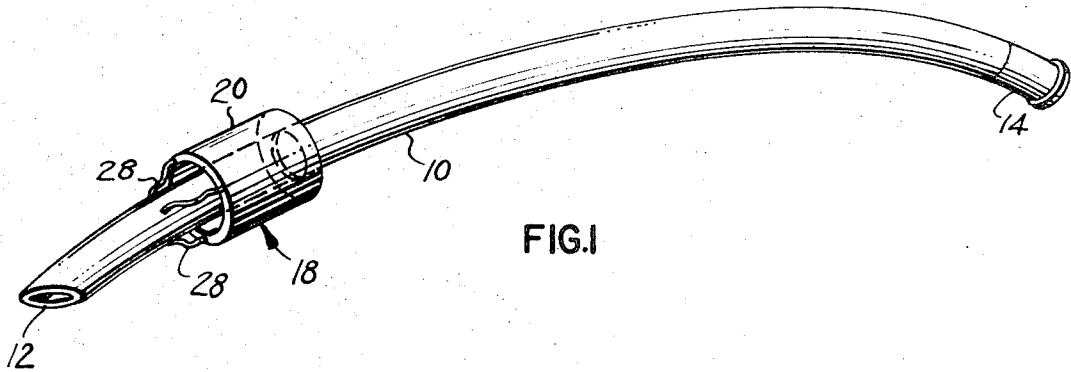

FIG. 1

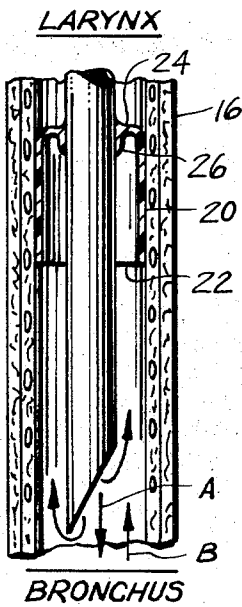

FIG. 2

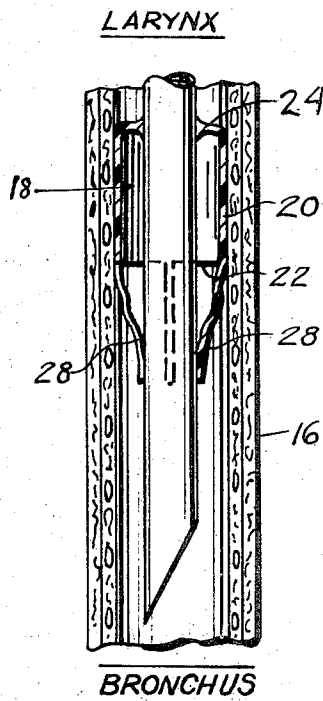

FIG. 3

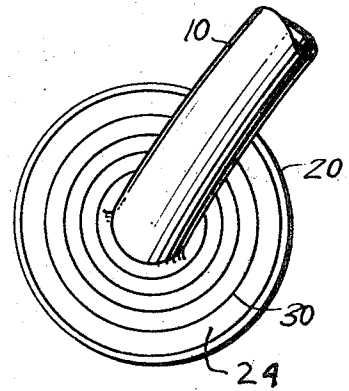

FIG. 4

INVENTOR.
ABRAHAM D. MERAV
BY
Thomas Schaffer
ATTORNEY

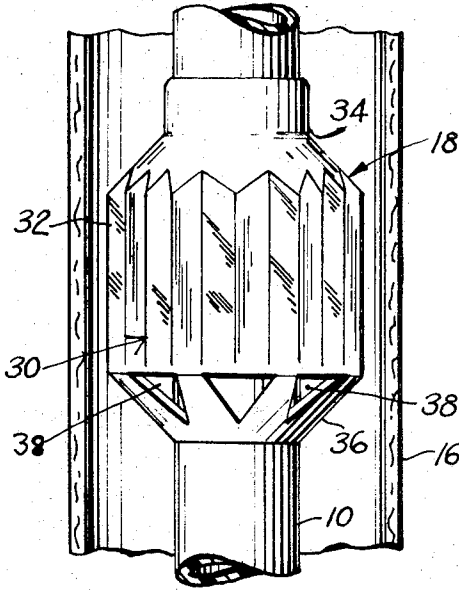

FIG. 5

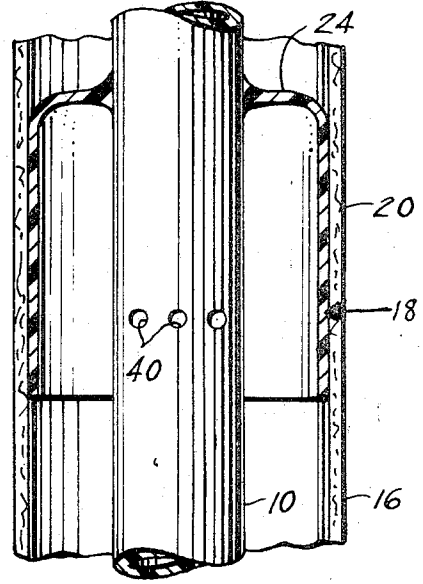

FIG. 6

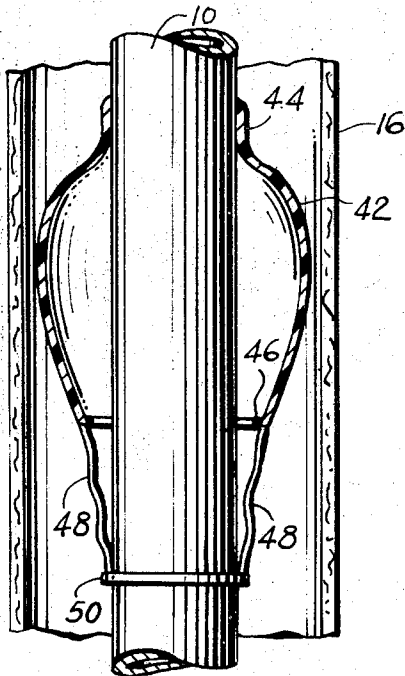

FIG. 7

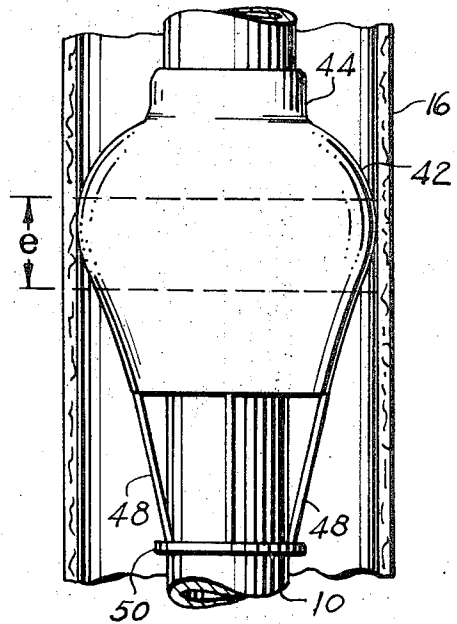

FIG. 8

INVENTOR.
ABRAHAM D. MERAV

BY *Wm. Schaffer*
ATTORNEY

MEDICAL DEVICES

BACKGROUND OF INVENTION

The present invention relates to apparatus for use in prolonged artificial respiration and in particular to improved intratracheal tube.

As an alternate to the supply of oxygen through tank, tent or chest respirator systems, recent treatment procedures for such serious illness as acute poliomyelitis call for ventilation by supplying auxiliary air under forced or positive pressure directly to the lungs through an endotracheal or tracheostomy tube (herein after sometimes referred to collectively as intratracheal tubes) inserted and left indwelling within the trachea. A pulsating supply of pressurized air automatically forces the rhythmic expansion of the lungs and maintains the chest and lungs properly inflated especially when the patient is unable to provide even the minimum muscular activity to sustain any breathing. Intubation has a further advantage in that it leaves the patient free of an enclosing housing or chest harness making the patient more accessible to observation and auxiliary treatment.

Since the body tends to reject and expel air which is artificially supplied and since the diameter of simple intratracheal tubes would normally allow the escape of air, the air is either supplied under extremely high pressures or as is preferable under low pressures by providing the tube with means for sealing the annular space between the tube and the trachea walls. Commonly, such means take the form of an elastic annular "cuff" of either a balloon of toroidal or spherical shape or an assembly of one or more flat discs, which are adapted to be independently inflated to seal against the mucosal lining and occlude the trachea.

An extensive survey of presently used "cuffed" intratracheal tubes was made by Drs. Carrol and Hedden in the September 1969 issue of the *Journal of Anesthesiology* (Vol. 31, No. 3, *Anesthesiology*, pages 275-281) to which reference can easily be made. Briefly such "cuffed" tubes fall within two categories namely, (a) those in which the "cuff" is an integral part of the tube, and (b) those in which the "cuff" is separable. In either case, the cuff requires a high degree of inflationary pressure and volume to extend into sealing condition and a high degree of what is referred to as "tracheal wall pressure" to maintain it sealed against the wall of the trachea. With these conventional "cuffs" the "tracheal wall pressure" is generally significantly greater than the pressure sustaining capillary blood flow so that blockage of blood (ischemia) through the mucous lining occurs. Particularly high pressure is required to distend the cuff against the force of its own residual elasticity (residual pressure), maintain the cuff in inflated condition against the pressure of the trachea or movement of the patient etc (intra-cuff pressure) and maintain the occlusion of the pressure against leakage of respiratory air (sealing pressure). As a result of both the intubation of an unnatural device and the maintenance of prolonged pressure against the mucous lining of the trachea serious side illnesses and complicating diseases, often worse than the respiratory illness itself occur. Not even the standard procedure of deflating the "cuff" for a few minutes or so every hour successfully overcome this problem.

The above problems are accentuated when one appreciates the fact that since the intubation is hidden

from view of the doctor or surgeon, accurate measurement of pressure cannot be obtained. It is thus more than likely that, in order to insure minimal efficiency the operator will set the pressure at a level even greater than that necessary for the secure occlusion of the trachea.

Recent medical literature is replete with studies and surveys of tracheal stenosis, tracheomalacia, ulceration, erosion of the tracheal wall, and the formation of lesions resulting from the prolonged intubation of intratracheal tubes. In the vast majority of such complicating diseases and injury, the cause has been traced directly to the employment of the cuff and the prolonged "tracheal wall pressure" required for its use. As a partial tabulation of such studies references can be made to the following articles; Catane et al, *British Journal of Anaesthesiology*, 1969 Vol. 41, page 1086; Grillo, H.C. *Journal of Thoracic and Cardiovascular Surgery*, January 1969, Vol. 57, No. 1 page 52; Shelly et al, *Journal of Thoracic and Cardiovascular Surgery*, May 1969, Vol. 57, No. 5 page 623; Fishman et al, *Annals of Thoracic Surgery*, July 1969, Vol. 8, No. 1, page 47; Miller et al, *Annals of Surgery*, Feb. 1970, Vol. 171, No. 2, page 283; and Westgate et al, *Anesthesia and Analgesia*, May-June 1970, Vol. 49, No. 3, page 393. The result of all the studies and findings in this field leads to the conclusion that while intratracheal supply of ventilation is extremely beneficial there is a need for an improved, less harmful intratracheal tube with means for occluding the tracheal passage.

It is the object of the present invention to provide an intratracheal tube having occluding means which overcome the drawbacks and dangers of the conventionally known devices.

It is another object of the present invention to provide a device of the type described which is simple in construction and easier to use.

It is another object of the present invention to provide apparatus of the type described which has tracheal occlusion means not requiring external inflation or maintenance in distended condition by the application of external air pressure.

It is another object of the present invention to provide an intratracheal tube having means for occluding the trachea operable by and as direct result of the internal breathing process or as a result of the applied auxiliary ventilating process.

It is a specific object of the present invention to provide a device of the type described which permits prolonged intubation of fluid feeding device without resulting in complicating side illnesses etc.

These objects, and others, as well as numerous advantages will be clearly observed from the following description of the present invention.

SUMMARY OF THE INVENTION

According to the present invention apparatus for intubation within body passages is provided comprising an elongated tube having an opening at the distal end and means for connection to a source of fluid, such as air, at its proximal end. Occlusion means is located about the surface of the tube near the distal end to seal the space between the passage and the tube against flow of air. The occlusion means comprises a bag or canopy secured at its center, to the outer surface of the tube being substantially open for receipt of air in a direction toward the distal end of said tube. The canopy

is adapted to be distended against the inner surface of the passage to form the required seal.

In the preferred form of the invention the canopy is bag like and is open along its distal end or end facing the open end of the tube, by providing it with a free edge radially spaced from the tube to receive a sufficient amount of air flowing backward into it so that it distends outwardly into contact with the surface of the body passage wall. The bag or canopy is preferably, but need not be integral with the tube itself, and can be held down at proximal the end by some connection with the tube.

The canopy can be made of either inelastic or elastic material but should be dimensioned so that in either case the canopy forms a firm and secure seal with the walls of the passage when distended without the need of excessive pressure to maintain it in that condition.

In one form of the apparatus the free edge portion has a diameter at least substantially equal to the diameter of the passage. In another form the free edge may be of smaller diameter so that it is prevented from contact with the surface of the passage.

The canopy may be spherical, cylindrical or conical in shape. Preferably it has a dome portion through the center of which passes the tube. The dome may be reinforced to provide it with a deformable but recoverable shape.

The free edge of the canopy may also be provided with a plurality of shroud lines which hold it to the tube somewhat like a parachute, or it may itself be extended to.

The foregoing is only a summary of the present invention. Full details of the invention and its preferred structural embodiments is set forth below.

BRIEF DESCRIPTION OF THE DRAWINGS

The following disclosure makes reference to the accompanying drawings in which:

FIG. 1 is a perspective view of the inventive occluding apparatus embodied in an intratracheal tube;

FIG. 2 is an enlarged vertical section of the device showing the canopy in use in a body passage such as the trachea,

FIG. 3 is a view similar to that of FIG. 2 showing a modified form of the device,

FIG. 4 is a perspective views of a canopy showing modified dome therefor,

FIG. 5 is view similar to FIG. 2 showing modified canopy having accordion bellow walls,

FIG. 6 is a view of still another modification, and

FIGS. 7 and 8 are detailed views of a second embodiment of the present invention.

Turning now to the drawings, the present invention is combined or applied to an otherwise conventional intratracheal tube 10 which may be made of rubber, plastic such as nylon, or even metal, such as silver. Since the present invention does not require that the tube be subject to high pressures, a silver tube is not necessary, and the preferred material should be either rubber or plastic for greater flexibility, control and lower cost. The distal or inferior end of the tube is provided with the usual slanted edge 12 which makes the insertion of the tube much easier. The proximal or posterior end of the tube is provided with a connecting member 14 by which it may be made to communicate with a source of air. The connecting member 14 is of

the type common in tracheal ventilation systems now in use.

The tube 10 can be made in varying lengths and of varying inner and outer diameters as is the practice in this art. The source of air (which is not shown) may be a tank and/or pump of any known type supplied with or without valve means for delivering a continuous or pulsating flow of air of regulated pressure and volume.

The trachea 16 as seen in the drawing is schematically shown; the various details, such as the mucous lining and the cartilaginous and membranous tissue of which it is composed being omitted for the sake of clarity. The tube 10 is adapted to be inserted within the trachea to extend in a direction from the larynx toward the bronchus. Essentially the present invention is suitable as both an endotracheal and as a tracheotomy tube and may therefore be inserted naso- or oro-trachially or by incision through the throat directly into the trachea below the larynx.

The details of insertion, as well as supply of air, pulsation, humidification, and the full range of therapy involved are all well known to those skilled in this art. Because of this and because reference can easily be made to the studies and papers mentioned earlier, such details are omitted here.

According to one form of the present invention the exterior of the intratracheal tube is provided, as seen in FIG. 2, with occluding means comprising a canopy generally depicted by the numeral 18, located near the distal end 12. The canopy is generally formed by a bag of cylindrical shape having a symmetrical wall 20 ending in a circumferential free edge 22 forming an open facing the lungs and at its posterior end in an enclosing dome wall 24, cephalad. The dome wall 24 is provided with a central hub 26 which surrounds and is integrally secured, adhered, or formed with the exterior surface of the tube 10.

Preferably, the canopy 18 is made of inelastic or slightly elastic plastic or synthetic material inert to the body fluid and chemistry. Material such as polyurethane, polypropylene, surgical rubber, or silicon rubber such as that sold by Dow-Corning under the Trademark "Silastic" are all suitable. The canopy as will be explained later is not required to be expanded or blown up as a rubber balloon in the fashion of the prior art "cuff" but is merely distended to assume a fixed shape under pressure of the ambient or moving air within the trachea. Consequently, elasticity of the material is not required. Although it is, on the other hand, not a detriment or hindrance to good working of the device.

In the embodiment shown in FIG. 2 the canopy wall is generally cylindrical and has an outer diameter at least substantially equal to the diameter of the trachea lumen or passage. The shape of the wall 20 is not critical nor is its length, however, in this form an important feature resides in the fact that the diameter of the circumferential free edge 22 or canopy wall 20 must be sufficient to lie, when the bag is filled with air, against the inner mucous walls of the trachea 16. The diameter of the edge 22 or canopy 20 may be larger than the inner diameter of the trachea since a certain degree of overlap of the material forming the wall 20 is permissible, however, it should not be smaller since air may pass between it and trachea wall leaking outwardly of the trachea. The axial length of the wall 20 should also be sufficient to engage and abut against the inner walls of the trachea for a sufficient distance to provide a seal-

ing area of sufficient size so that small creases, folds, pockets, or voids in either the wall of the bag or in the wall of the trachea are completely covered and sealed.

As is known, the trachea itself has an oval cross section and consequently while cylindrical circular cross sectioned canopies may be simple to construct, the canopy may be ovaloid, elliptical in cross section, or any other shape. The flexibility and distendibility of the material used will enable the canopy to conform to the shape of the trachea.

The shape of the wall 20 may be somewhat modified in the form of a sphere, however, in accordance with the form shown in FIG. 2 the overall outer diameter of the free edge should be of the size at least substantially equal to the diameter of the passage.

The canopy shown in FIG. 2 may be embodied in a number of ways. For example in FIG. 3 the canopy is provided with a plurality of conically arranged shrouds or strips 28 which function to hold down the free edge 22 during insertion of the tube in the body passage. The shrouds lines may be formed of the same material as the canopy 18, and are integrally connected to the free edge 22 and the outer surface of the tube 10. Preferably, the length of each is equal to that of the others and greater than a straight line drawn between the surface of the tube 10 and the inner surface of the trachea at the points where the ends of the shrouds 28 contact. The shrouds or strips 28 permit the intratracheal tube 10 to be inserted in the trachea without the aid of a Penrose drain or other covering means and yet be assured that the free edge 22 will not curl, ravel or invert. The extra length of the shroud will however, insure that the free edge or canopy wall distend completely to the wall of the trachea.

In FIG. 4, the canopy is shown as formed with a plurality of concentric rings 30 imbedded in the dome or bottom wall 24, the concentric rings provide a constant canopy structure with spread walls 20 which depend freely therefrom. This construction provides an always open canopy which is pressed toward the wall of the trachea by only a minimal differential in air pressure. The rings may be rubber, plastic, or metal although soft deformable plastic is preferred.

The dome 24 may be also formed with a plurality of radially arranged spokes which function similarly to the rings 30 of FIG. 4, although they are deformable in a different manner. The canopy dome may be made of a greater thickness to provide suitable firmness.

In FIG. 5 still another form of the present invention is shown in which the canopy is formed similar to that of a bellows having a wall 30 formed of a circumferentially arranged longitudinally extending alternating series of inward and outward pleats 32. As seen in FIG. 5, the bellows has a proximal collar 34 which is attached in sealed condition about its center to the tube 10 in the manner previously shown.

In FIG. 6 still another form is shown wherein the tube 10 itself is provided with one or more small holes 40 extending radially through its wall and directed toward the side walls 20 of the canopy 18. Such holes permit the escape of small amounts of air against the side wall 20 during inspiration creating a positive pressure against it and forcing it securely against the mucous lining of the trachea. If desired, the provision of the holes 40 permits suction to be applied to the tube, drawing the walls 20 against the tube. The intubation of the tube may then not require a cover such as the Penrose

drain or it may be useful as a means of controlling bypass of air should therapy so require it.

In FIGS. 7 and 8 still another form of the present invention is shown. In this embodiment the canopy 42 has a generally bulbous, onion like conical configuration. The tube 10 passes through a collar 44 at the apex of the cone which is integrally sealed or secured within any of the prior forms to render the canopy sealed against passage of air. As seen in FIG. 7, the free edge 46 is rolled or hemmed to provide a reinforced edge which has only limited elasticity relative to the remainder of the canopy. The rolling or hemming of the free edge can be simply obtained when plastic or rubber material is used by gluing or heat sealing.

Unlike the prior forms the present canopy 42 is provided with a free edge 46 which may be narrower in diameter than the diameter of the body passage 16. Because the edge is rolled or hemmed it has limited elasticity preventing it from contacting or engaging the inner surface or lining of the body passage. When air, however, fills the canopy, the conical wall portions distend upwardly and outwardly and the central peripheral surfaces thereof contact the lining walls effecting the occlusion of the passage. The free edge maintains its circular cross section even when the canopy is extended, permitting only the conical wall to distend creating curved contacting surfaces with the lining of the trachea, as seen in FIG. 8.

While the canopy in this embodiment might have some degree of elasticity it is not absolutely necessary. The elasticity would allow the canopy to bulge and form the contacting engagement. However, the same bulge can be made with an inelastic material since the conical canopy has a slightly bowed or curved vertical cross section.

In the embodiment shown in FIG. 7, a plurality of shroud lines 48 may be provided to hold the peripheral free edge 46 taut. Since, the free edge is not intended to be elastic or even to distend, the lines 48 may be of a shorter length than required in the form illustrated earlier. In fact, the lines 48 can be so short as to extend radially, like spokes in the plane of the free edge. The lines 48 may be secured by a circular band 50 sealed to the tube. The shrouds act to hold the edge 46 and to force the creation of the roll or bulge in the conical bag.

In any event the overall circumference or diametrical dimension of a canopy employing an inelastic hem or free edge must be substantially equal to the diameter of the body passage so that when it is distended it will occlude the passage. Excess pressure on the surface is to be avoided as well as the need to extend the canopy beyond elastic limits. An advantage of this embodiment over the preceding one lies in the fact that the free edge portion does not contact the lining of the body passage and consequently a resilient or elastic material may be used without fear that its free edge will cut into the wall. In some body passages the elastic canopy may be preferred since it will more easily conform to the irregular mucous linings.

The devices of the present invention are indeed very simple and in this simplicity lie the benefits and advantages not obtained by the prior art. Operatively the device such as the intratracheal tube is inserted within the trachea in any one of the known ways previously discussed. For ease of insertion a Penrose drain may be used to surround the tube which is later removed once

the tube 10 is fully inserted. Once intubation is accomplished the connector 14 is attached to the source of air and ventilation begun. In the inspiration portion of the ventilation cycle, air is supplied to the patient at a pulsating rhythm, pressure, and volume desired for proper therapy. The air passes through the tube exiting from the distal end 12 in the direction of the arrow A (FIG. 2) toward the bronchus. Since air like all fluid tends to take multiple paths, particularly the one of least resistance, a certain amount of air bends upwardly and flows axially along the outer surface of the tube 10. The upwardly flowing air enters into the canopy and opens it radially outwardly. In the forms of FIGS. 2 and 3 the wall 20 engages the inner surface of the trachea 16, since the free edge 22 has a diameter at least equal to the inner diameter of the trachea. Any amount of air within the bag having a differential or ΔP greater than atmosphere will force the canopy to lie snugly and securely about the entire circumference of the inner wall of the trachea. Air thereafter completely fills the bag of the canopy forcing the axial extend of wall 20 against the mucous surface preventing passage of air or leakage during the inflow portion of ventilation cycle. During the expiration portion of the ventilation process, the patient either voluntarily or forcibly exhales air in a stream labeled by the arrow B. The exhalation portion of the cycle is not under forced or positive inward pressure. This lack of pressure in the conventional intratracheal tubes would, but for the independent inflation of the cuff, cause a collapse of the seal between tube and trachea surface. Here, however, the reverse flow of air B passes in a major stream upwardly through the tube 10 and in a minor stream about the outer surface of the tube 10 into the canopy. The exhaled air functions similarly to the inflowing air to fill the canopy and maintain the wall 20 firmly pressed against the inner wall of the trachea.

The ventilation cycle produces a generally sine-wave flow of air in which, during the inspiration cycle a flow of air occurs in one direction, while in the expiration of the cycle a flow of air occurs in an opposite direction. At an instant of time the flow of air may be at a standstill or zero value (i.e. between the forward and reverse flow), and the canopy relaxes from its distended position receding from the surface of the lining. This has a beneficial effect in that it positively avoids prolonged blockage of capillary blood flow and ischemia, should it ever occur. The canopy itself, takes on a modified pulsation responsive to the flow of air rhythmically distending and receding. This has a beneficial effect on the lining of the passage since at the zero pressure period, the surface of the passage is instantaneously free of pressurized contact with the canopy. The periodic deflation is automatic and responsive to the rhythmic ventilation and obviates the need for the hourly relaxation of the "cuff" and shutting down of the ventilation process. Notwithstanding this rhythmic deflation, the canopy does not collapse, so that effective occlusion is never lost. The passage remains effectively blocked because of only the instantaneous relaxation.

Notwithstanding the open end of the canopy, the bag 18 as shown in FIG. 2, will not reverse itself under the pressure of either air stream A or B. The surface tension between the bag and the mucous lining of the trachea 16, together with the size and diameter of the bag, prevent inversion of the bag. The canopy, shown in FIG. 3 and FIGS. 7 and 8 having shroud lines or being

secured to the tube at the distal end, cannot invert or reverse itself, under any condition.

The canopy shown in FIGS. 7 and 8 operate much in the same way as those shown in FIGS. 2 and 3, for example. Here the inextensible edge or rolled hem prevents the canopy from distending along its entire length. However, the flexing of the canopy itself and the distending of the walls provides ample sealing surface. The conical shape and smaller diameter distal end secured to the tube by short shrouds forms a more cohesive unit which can be handled with great ease without fear of harming the device itself. It also enables the device to be inserted within the body passage with greater ease and without the use of drains, etc. The conical shape and the outward and upward distending of the canopy seems also to provide a more secure seal and occlusion.

A startling advantage arises from all forms of the present invention, in that the low pressure necessary to distend the canopy is equal to ventilatory pressure and the pressure within tube 10. Therefore, since all pressures are substantially equal, the tube need not be made of the heavy, thick wall or strong tubing required by the prior art to prevent intratube occlusion but may, in fact, be made of a soft pliable thin walled material. Such material is more comfortable to the patient, and permits easier intubation.

Further advantages and forms of the invention will be observed. Various circumferential levels of the canopy can be provided with different thicknesses so as to be more or less extendible and more or less rugged. Thus, for example, the canopy, as seen in FIGS. 7 and 8, can have its dome 44 formed of a thicker material and with its central equatorial section, denoted by the dotted lines of lesser thickness, so that the dotted equatorial portion may be more readily distended into contact with the surface of the body passage. This can be easily accomplished when forming the invention of plastic or rubber by known dipping or molding techniques.

Among the various alternatives possible, are the numerous combinations and permutations available from the forms earlier shown. For example, the entire conical canopy 42 of FIGS. 7 and 8 can also be made with pleats in the form of the bellows shown in Fig. 5, or the pleats may be the equatorial portion only. The conical bag may be made also to extend distally to the tube as a unitary piece and the shrouds formed by cutting holes in the bag to open the bag to incoming air. The earlier shown forms may be provided with rolled or hemmed free edges, of either smaller diameter or equal diameter, to the body passage. Any of the embodiments may be provided with reinforced domes or side walls. Other combinations will now be apparent.

The present invention has been described as being integrally constructed on the surface of an endotracheal tube. It will be appreciated that it can easily be formed as a separable member, by converting the tube 10, shown in each of the embodiments, into a sleeve of finite length. The sleeve, which can be relatively thin rubber, plastic or even metal, is then adaptable to be slid over the end of an existing endotracheal tube of either the flexible plastic or rubber type or over the inflexible sliver type. Functioning of the device, of course, remains the same. It will also be appreciated that the present device can be used with a conventional "cuff" as an auxiliary or initiating occlusion device as may be desired.

It will thus be seen that the present device functions entirely differently than the prior art devices. In the first place the canopy is always open and is not inflated independently. Secondly, the bag does not assume the shape of an annular balloon or toroidal ring. In fact the present bag takes the form more closely approximating that of a parachute and is inflatable or openable only on the passage of air into its open end. Thirdly, the opening of the bag is not dependent upon overcoming any residual elasticity of its material. In fact, the elasticity of the bag plays little or no part at all in its structural formation or in the creation of the seal itself. Fourthly, the canopy is not maintained in open position by the superimposition of an independent volume or pressure of air. The intra bag (intra-cuff) pressure is exactly the same as that pressure exerted by the inhaling air stream A and the exhaling air stream B, both of which are more natural to the patient than any pressure employed in inflating the prior cuffs of the prior art. Above all, the sealing pressure, required to make the perfect seal is also equal to the pressure of the flowing streams A and B and is not in excess to the normal pressure exerted against the mucous linings. The pressure required to inflate or distend the canopy is only at a level slightly above atmosphere (i.e. the ΔP between the air in the trachea and the atmosphere is only very small) the actual pressure exerted by the present device on the surface of the passage should not exceed 30 cm/H₂O. This pressure is well below the pressure which blocks capillary blood flow and therefore ischemia is obviated. The pulsation of the canopy also prevents blood stoppage.

Laboratory tests performed with dogs have been made over a long period. These tests have shown successful use of the device. Curarized dogs have been maintained with the present device for periods exceeding 10 hours at pressures of between 15 - 20 cms/H₂O, at tidal volume of 400-500 cc with no significant leakage. Ventilatory support for 72 hours produced no visible gross or even microscopic tracheal damage. Similar tests, but over a prolonged period of ventilation, continue to be carried out, current indications are that positive respiratory assistance can be obtained over indefinite periods without tracheal damage or with only minimal and largely insignificant damage.

There are but a few of the embodiments to which the present invention may be applied. Numerous others will now be readily apparent to those skilled in this art. The essential feature of each embodiment is the canopy construction which has a free edge defining an open end directed toward the lungs and an enclosed dome cephalad whereby the air inherent in the procedure is employed to distend the canopy and maintain it in sealed position against the wall of the trachea.

Having described the present invention it will be also obvious that the objects set forth for it have been met. The present device is simple and of low cost. The present device is safer and less injurious to the body than the prior art. The present device provides a safe and effective occlusion means without the use of excess pressure. The present device does not require external air

pressure to maintain its sealing pressure. Furthermore, the present device enables prolonged intubation.

Since various changes, modifications, equivalent structures may be employed, it is intended that the present disclosure be illustrative of the invention and it should therefore not be taken in any limiting or restricting manner.

What is claimed:

1. A device for intubation in a tracheal passage or the like, comprising a hollow tube having a distal end for insertion into said tracheal passage and a proximal end adapted to be connected to means for selectively delivering a gas through said tube, a canopy of flexible material surrounding said tube, spaced proximally of said distal end for preventing back flow of gas in said passage about said tube, said canopy comprising a dome portion having an edge oriented to the proximal end of said tube, an expandable body portion and a relatively non-expandable distal edge oriented to the distal end of said tube, said proximal edge of said dome portion being secured to the outer surface of said tube to prevent substantial movement of gas therebetween, said distal edge having a circumference less than the greatest circumference of the body portion when said body portion is distended and being spaced radially from the surface of said tube to permit gas to freely flow into said canopy, said body portion being expandable by said gas to distend within the passage to occlude the same.

2. The device according to claim 1, including means connecting the distal edge of said canopy to the surface of said tube to limit proximal movement and lateral shifting of said edge relative thereto.

3. The device according to claim 2 wherein the connecting means comprise one or more shroud lines about the distal edge, said shroud lines extending to the surface of said tube.

4. The device according to claim 2 wherein the dome portion of said canopy is substantially circular and said body portion is symmetrical about said tube, the distal edge of said canopy lying in a plane substantially perpendicular to the tube.

5. The device according to claim 1 including supporting members integrally formed with said dome portion and symmetrical with the axis of said tube for maintaining said dome in distended position.

6. The device according to claim 1 wherein said canopy is formed with a plurality of pleats expandable under air pressure.

7. The device according to claim 1 wherein the distal edge of said canopy is provided with a circumferential reinforcing member.

8. The device according to claim 1 wherein said canopy is formed with circumferential areas of at least two different degrees of expandability.

9. The device according to claim 1 wherein said canopy is secured to said tube by means permitting its selected removal.

* * * * *