



US 20150337371A1

(19) **United States**

(12) **Patent Application Publication**
Weitz et al.

(10) **Pub. No.: US 2015/0337371 A1**

(43) **Pub. Date: Nov. 26, 2015**

(54) **CREATION OF LIBRARIES OF DROPLETS
AND RELATED SPECIES**

Publication Classification

(71) Applicant: **President and Fellows of Harvard
College, Cambridge, MA (US)**

(51) **Int. Cl.**
C12Q 1/68 (2006.01)

(72) Inventors: **David A. Weitz, Bolton, MA (US);
Jeremy Agresti, Richmond, CA (US)**

(52) **U.S. Cl.**
CPC **C12Q 1/6876** (2013.01)

(21) Appl. No.: **14/812,954**

(57) **ABSTRACT**

(22) Filed: **Jul. 29, 2015**

Related U.S. Application Data

(63) Continuation of application No. 13/119,470, filed on
May 4, 2011, filed as application No. PCT/US09/
05184 on Sep. 17, 2009.

(60) Provisional application No. 61/098,674, filed on Sep.
19, 2008.

The present invention is generally related to systems and methods for producing a plurality of droplets. The droplets may contain varying species, e.g., for use as a library. In some cases, the fluidic droplets may be rigidified to form rigidified droplets (e.g., gel droplets). In certain embodiments, the droplets may undergo a phase change (e.g., from rigidified droplets to fluidized droplets), as discussed more herein. In some cases, a species may be added internally to a droplet by exposing the droplet to a fluid comprising a plurality of species.

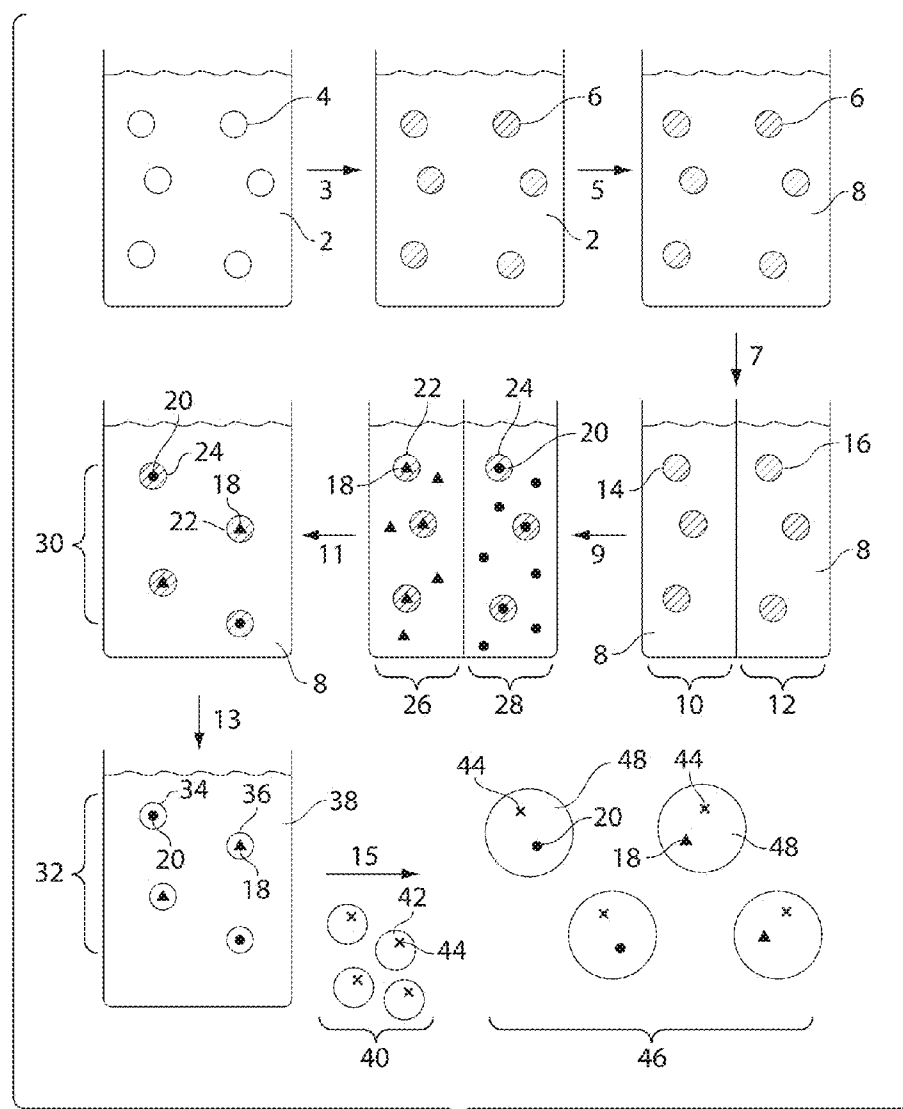

Fig. 1

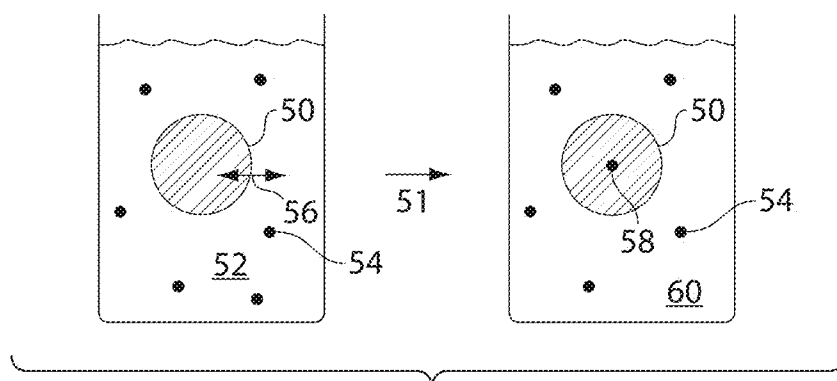

Fig. 2A

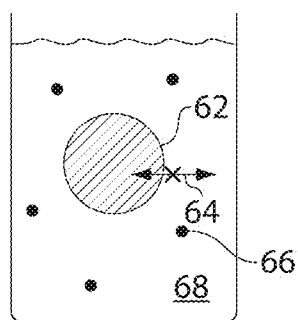
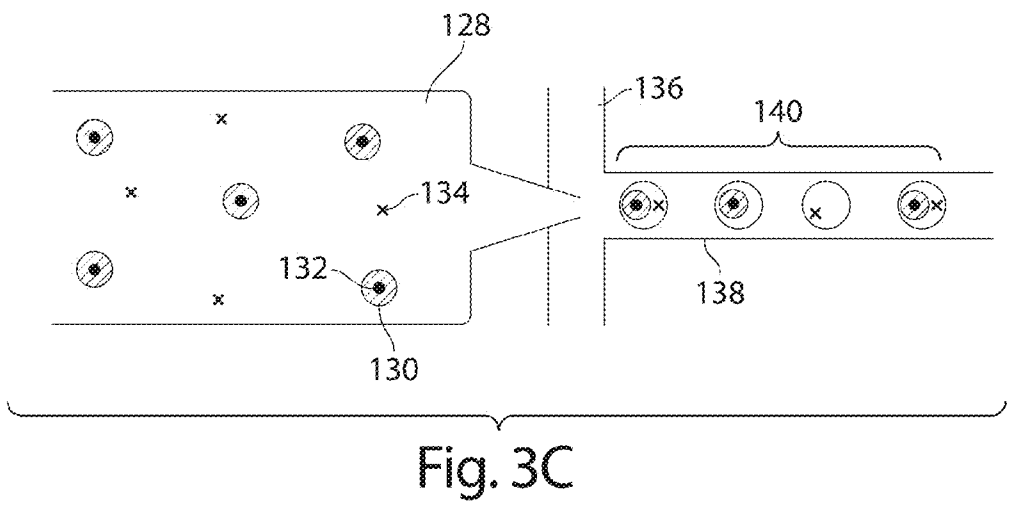
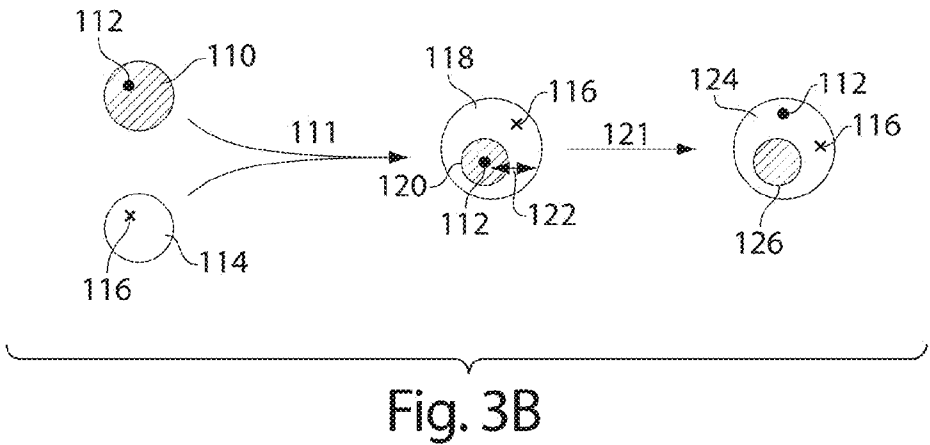
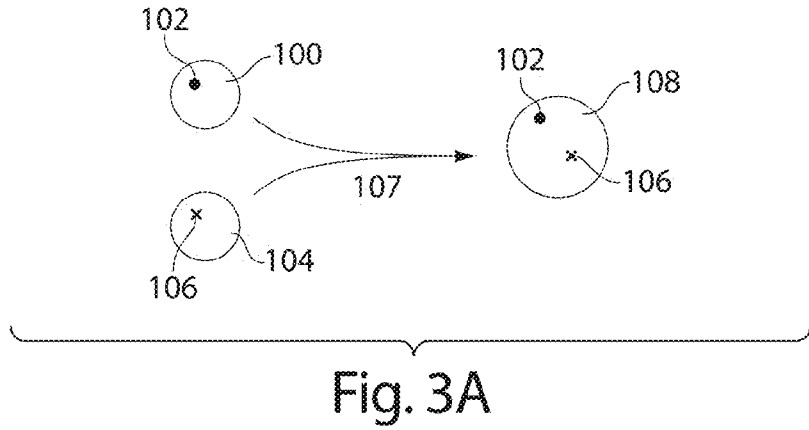

Fig. 2B



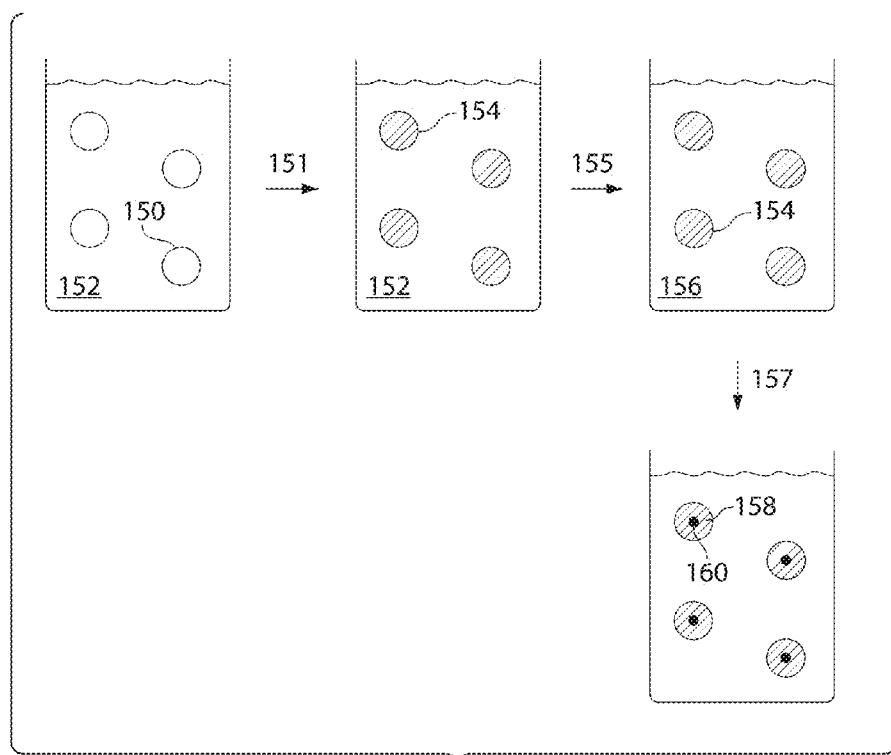

Fig. 4

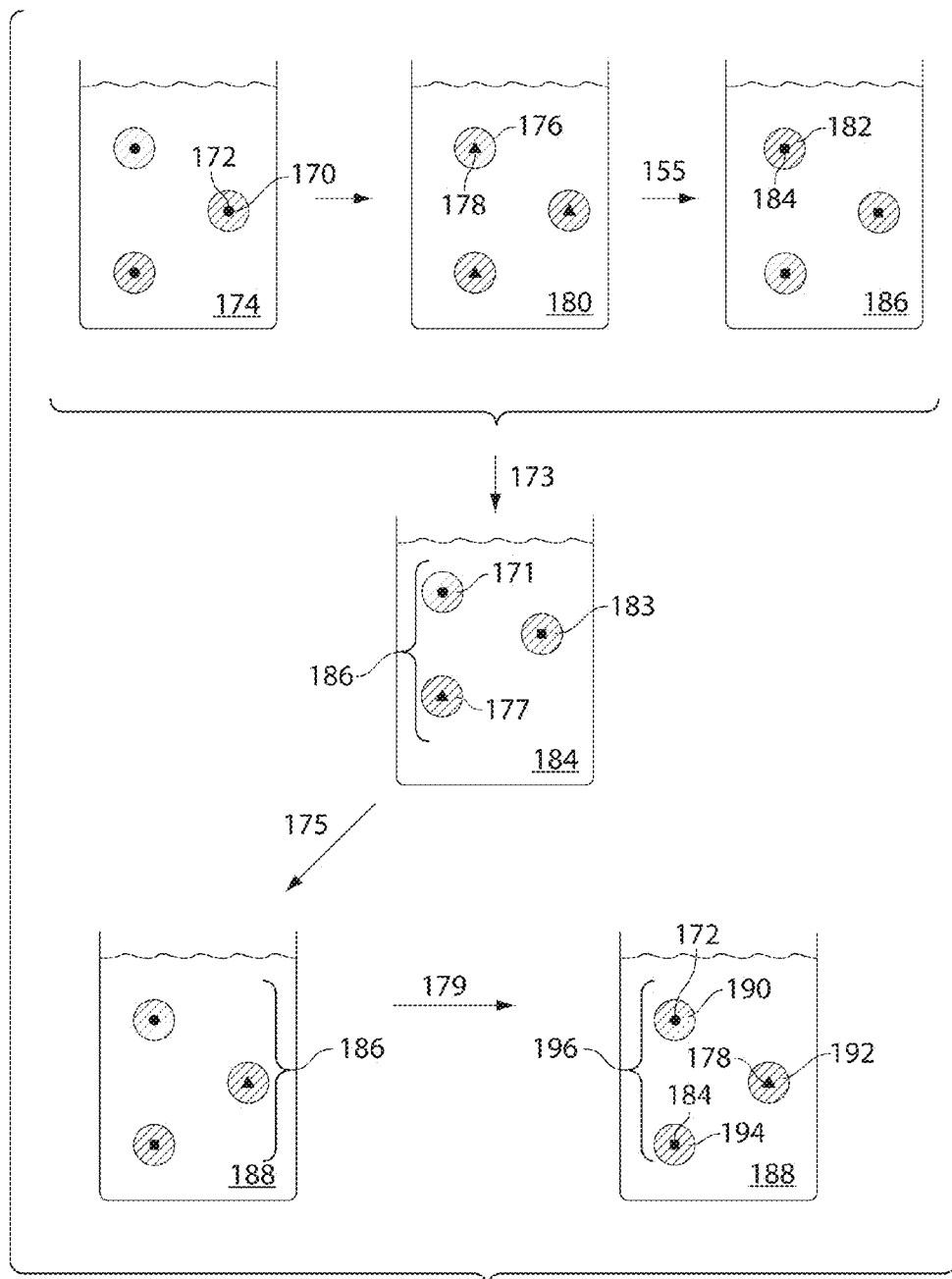

Fig. 5

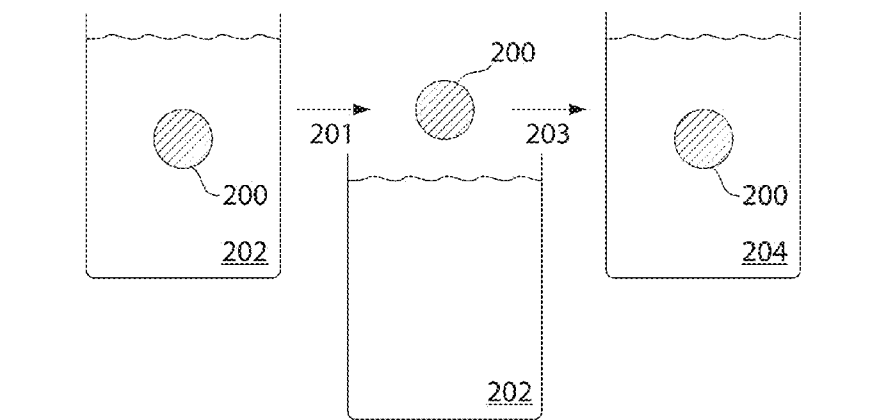

Fig. 6A

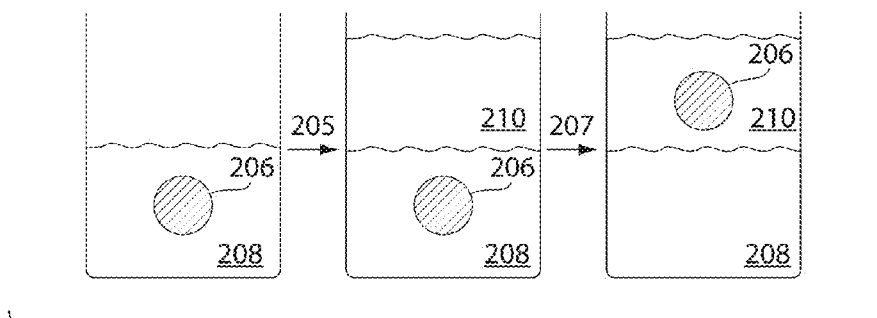

Fig. 6B

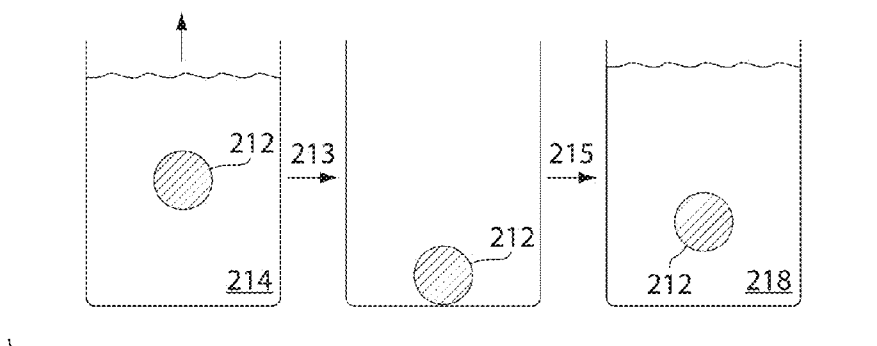

Fig. 6C

X = NUCLEIC ACID
RESIDUE
XXXX

Fig. 7A

XXXXXX

Fig. 7B

XXXXXXX

Fig. 7C

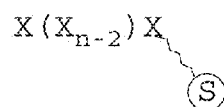

Fig. 7D

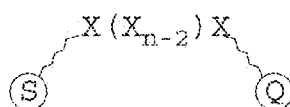

Fig. 7E

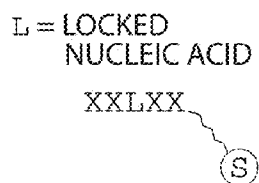

Fig. 7F

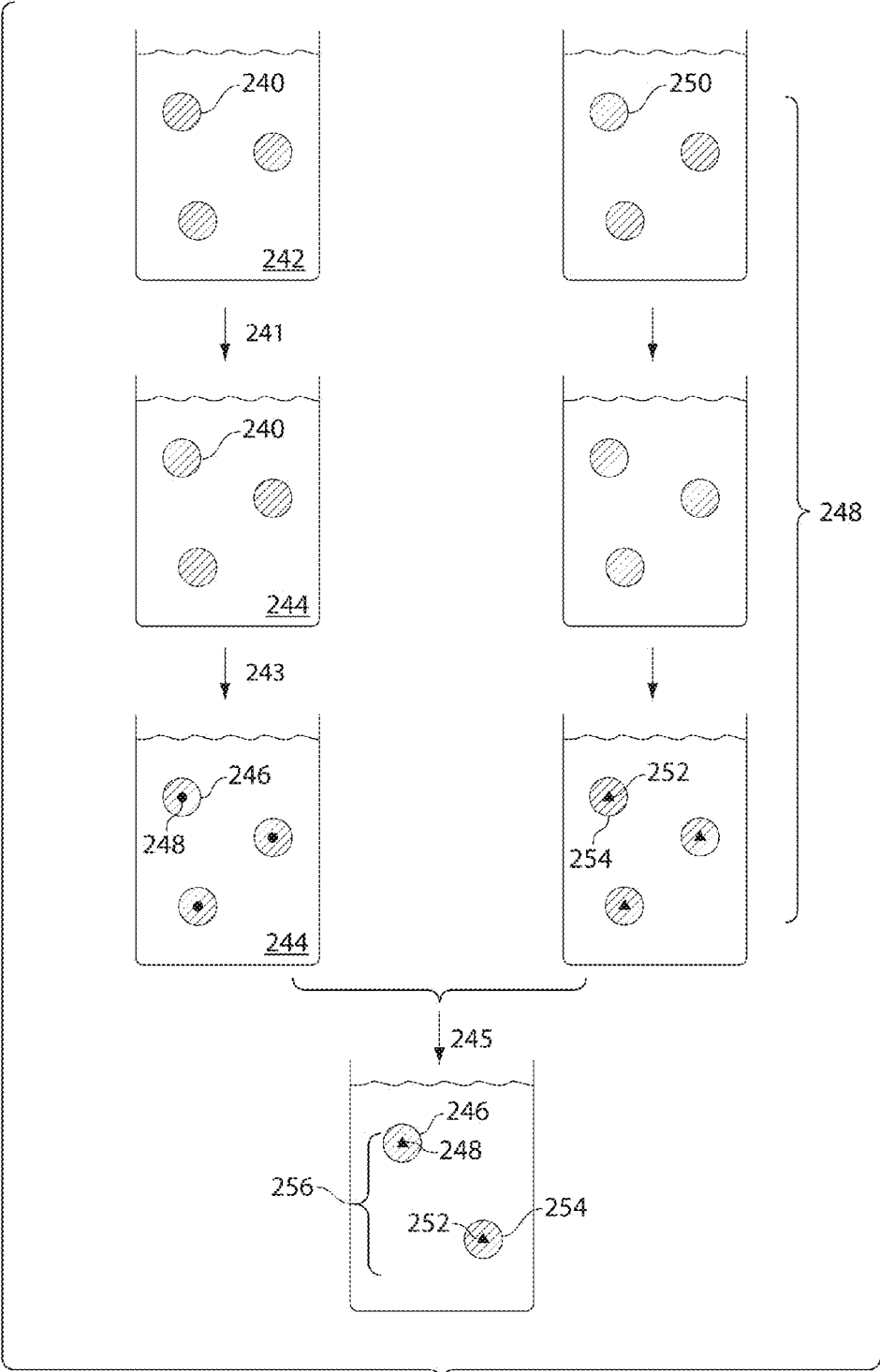

Fig. 8

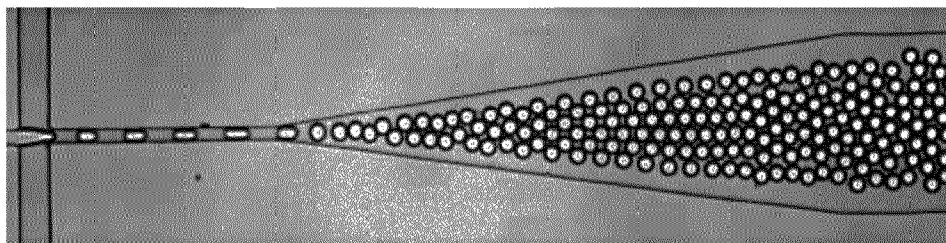

Fig. 9A

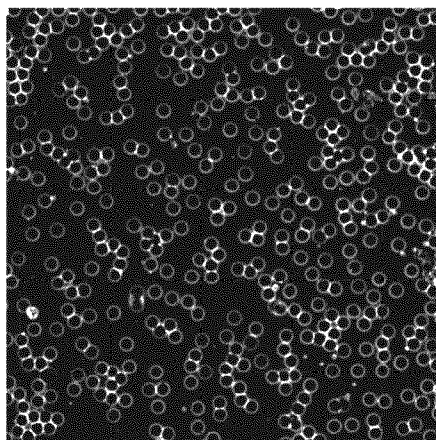

Fig. 9B

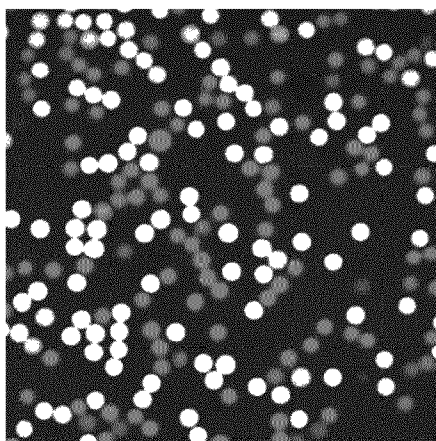

Fig. 9C

CREATION OF LIBRARIES OF DROPLETS AND RELATED SPECIES

RELATED APPLICATIONS

[0001] This application claims the benefit of U.S. Provisional Patent Application Ser. No. 61/098,674, filed Sep. 19, 2008, entitled "Creation of Libraries of Droplets and Related Species," by Weitz, et al., herein incorporated by reference.

GOVERNMENT FUNDING

[0002] This invention was made with government support under DMR-0602684 awarded by the National Institutes of Health. The U.S. government has certain rights in the invention.

FIELD OF INVENTION

[0003] The present invention is generally related to systems and methods for producing a plurality of droplets. The droplets may contain varying species, e.g., for use as a library. The droplets may be rigidified and/or fluidized, in some cases.

BACKGROUND

[0004] Various technologies have been developed that allow production of "libraries" of synthetic compounds (e.g., pharmaceutical agents, inhibitors, etc.) or nucleic acid probes, etc. A library of synthetic compounds may be used to screen for a target analyte molecule (e.g., an enzymes, an antibody, etc.) having a desired activity. Although current libraries are valuable, commercially-available resources useful in the search to identify new compounds with desirable activities, there are practical difficulties (e.g., cost, time, equipment, etc.) associated with the preparation, storage, and use of current technologies.

SUMMARY OF THE INVENTION

[0005] The present invention is generally related to systems and methods for producing a plurality of droplets. The droplets may be rigidified and/or fluidized, in some cases. The subject matter of the present invention involves, in some cases, interrelated products, alternative solutions to a particular problem, and/or a plurality of different uses of one or more systems and/or articles.

[0006] In one aspect, the invention is directed to a method. According to a first set of embodiments, the method includes acts of providing a plurality of droplets, each of the plurality of droplets comprising a first fluid and being surrounded by a second fluid, wherein the first fluid and the second fluid are substantially immiscible, causing at least some of the plurality of droplets to undergo a phase change to form a plurality of rigidified droplets, exposing the plurality of rigidified droplets to a third fluid, wherein the third fluid is substantially miscible in the first fluid, and adding at least one first species internally to at least some of the rigidified droplets.

[0007] In one set of embodiments, the method includes acts of providing a plurality of groups of rigidified droplets, each of the groups of rigidified droplets comprising a first fluid and having substantially the same composition as the other groups of rigidified droplets but containing a distinguishable species with respect to the other groups of rigidified droplets, forming a suspension comprising at least one rigidified droplet from each of the groups of rigidified droplets, exposing at least some of the rigidified droplets of the suspension to a

second fluid, wherein the first fluid and the second fluid are substantially immiscible, and fluidizing at least some of the rigidified droplets to form a plurality of fluidized droplets, wherein the plurality of fluidized droplets are substantially immiscible in the second fluid.

[0008] In another set of embodiments, the method includes acts of providing a first plurality of rigidified droplets, each rigidified droplet being surrounded by a second fluid, the rigidified droplets being formed from a fluidic droplet comprising a first fluid, wherein the second fluid is substantially immiscible in the first fluid, exposing the first plurality of rigidified droplets to a third fluid, wherein the third fluid is substantially miscible in the first fluid, adding at least one first species internally to at least some of the first plurality of rigidified droplets to form a first group of species-containing droplets, repeating the above acts with a second plurality of rigidified droplets and a second species to form a second group of species-containing droplets, and forming a suspension comprising at least some droplets of the first and second groups of species-containing droplets.

[0009] In still another set of embodiments, the method includes the acts of providing a plurality of droplets, each of the plurality of droplets comprising a first fluid and being surrounded by a second fluid, wherein the first fluid and the second fluid are substantially immiscible, causing at least some of the plurality of microfluidic droplets to undergo a phase change to form a plurality of rigidified droplets, exposing the plurality of rigidified droplets to a third fluid, wherein the third fluid is substantially miscible in the first fluid, separating the plurality of rigidified fluidic droplets into at least a first group of rigidified droplets and a second group of rigidified droplets, adding at least one first species internally to at least some of the rigidified droplets of the first group and at least one second species internally to at least some of the rigidified droplets from the second group, wherein the second species is distinguishable from the first species, forming a suspension comprising at least one rigidified droplet from each of the groups of rigidified droplets, fluidizing at least some of the rigidified droplets to form a plurality of fluidized droplets, and forming a plurality of microfluidic droplets, wherein each microfluidic droplet comprises at least one rigidified droplet.

[0010] In still yet another set of embodiments, the method includes the acts of providing a first plurality of rigidified droplets, immobilizing at least one first species internally with respect to at least some of the first plurality of rigidified droplets to form a first group of species-containing droplets, repeating the above acts with a second plurality of rigidified droplets and a second species to form a second group of species-containing droplets, and forming a suspension comprising at least some droplets of the first and second groups of species-containing droplets.

[0011] In another aspect, the invention is directed to a composition. In some cases, the composition comprises a container comprising at least eight mutually distinguishable rigidified droplets, each having substantially the same composition but containing a distinguishable species with respect to the other rigidified droplets.

[0012] Other advantages and novel features of the present invention will become apparent from the following detailed description of various non-limiting embodiments of the invention when considered in conjunction with the accompanying figures. In cases where the present specification and a document incorporated by reference include conflicting and/

or inconsistent disclosure, the present specification shall control. If two or more documents incorporated by reference include conflicting and/or inconsistent disclosure with respect to each other, then the document having the later effective date shall control.

BRIEF DESCRIPTION OF DRAWINGS

[0013] Non-limiting embodiments of the present invention will be described by way of example with reference to the accompanying figures, which are schematic and are not intended to be drawn to scale. In the figures, each identical or nearly identical component illustrated is typically represented by a single numeral. For purposes of clarity, not every component is labeled in every figure, nor is every component of each embodiment of the invention shown where illustration is not necessary to allow those of ordinary skill in the art to understand the invention. In the figures:

[0014] FIG. 1 depicts a method for forming a suspension comprising two groups of droplets and for fusing the suspension of droplets with a plurality of analyte droplets, according to some embodiments of the present invention.

[0015] FIGS. 2A and 2B depict non-limiting embodiments of the exchange of fluids that may occur between a droplet and the fluid substantially surrounding the droplets, according to some embodiments of the present invention.

[0016] FIGS. 3A and 3B illustrate the fusing of an analyte droplet with a fluidized droplet or a rigidified droplet, respectively, to form a microfluidic droplet, according to some embodiments of the present invention.

[0017] FIG. 3C illustrates the formation of a microfluidic droplet comprising a species and/or a target analyte molecule.

[0018] FIG. 4 illustrates a method for forming a plurality of rigidified droplets according to one embodiment of the present invention.

[0019] FIG. 5 depicts a method for forming a plurality of fluidized droplets comprising distinguishable species, according to some embodiments.

[0020] FIGS. 6A-6C show various methods for exposing a droplet of the present invention to a fluid.

[0021] FIGS. 7A-7F show non-limiting examples of nucleic acid probes.

[0022] FIG. 8 illustrates a method for forming a plurality of rigidified droplets according to one embodiment of the present invention.

[0023] FIG. 9A shows the formation of a plurality of droplets comprising DNA oligonucleotides, according to one embodiment.

[0024] FIG. 9B shows the plurality of droplets formed in FIG. 9A following rigidification and exposure to water, according to one embodiment.

[0025] FIG. 9C shows a fluorescent microscope image of a first group of rigidified droplets comprising a first DNA oligonucleotide and a second group of rigidified droplets comprising a second DNA oligonucleotide, respectively, and which have been visualized by exposure to a two distinguishable labeled oligonucleotides, according to one embodiment of the present invention.

DETAILED DESCRIPTION

[0026] The present invention is generally related to systems and methods for producing a plurality of droplets. The droplets may contain varying species, e.g., for use as a library. In some cases, the fluidic droplets may be rigidified to form

rigidified droplets (e.g., gel droplets). The droplets may undergo a phase change (e.g., from rigidified droplets to fluidized droplets), as discussed more herein. In some cases, a species may be added internally to a droplet, such as a rigidified droplet by exposing the droplet to a fluid comprising the species. After introduction, the species may be contained within the droplet, for instance, reacted within the droplet, and/or the fluid surrounding the droplet may be replaced by a fluid that is relatively unfavorable to the species.

[0027] The present invention, in some embodiments, provides methods for forming a composition comprising a plurality of droplets, where the droplets may be fluidic or rigid. In some cases, the method provides a plurality of droplets containing a first fluid and being substantially surrounded by a second fluid, where the first fluid and the second fluid are substantially immiscible (e.g., droplets containing an aqueous-based liquid being substantially surrounded by an oil-based liquid). At least some of the droplets may be caused to undergo a phase change to form a plurality of rigidified droplets (e.g., a plurality of gel droplets). The gel droplets may be exposed to a third fluid which is substantially miscible with the first fluid (e.g., an aqueous-based liquid) and the rigidified droplets may be separated into at least a first group of rigidified droplets and a second group of rigidified droplets. At least one first species may be added internally to some of the first group of rigidified droplets and at least one second species may be added internally to the second group of rigidified droplets, where the first species and the second species are distinguishable with respect to the other species. A suspension may be formed comprising at least one of the first group of species-containing droplet and at least one of the second group of species-containing droplets. In some cases, the suspension of rigidified species-containing droplets may be fluidized (e.g., phase change from a gel to a liquid) and a plurality of fluidized droplets may be formed. In certain embodiments, a plurality of microfluidic droplets is formed (e.g., by fusing the rigidified droplet with another fluidic droplet) which each comprise at least one fluidized droplet, and in some cases, as least one target analyte molecule.

[0028] In some embodiments, the invention provides systems and methods for forming a plurality of droplets, where the plurality of droplets comprises various groups of droplets containing at least one distinguishable species with respect to other groups. For example, the plurality of droplets may comprise a first group of droplets and a second group of droplets, where each of the first group of droplets contains a first species and each of the second group of droplets contains a second species. The plurality of droplets can be formed by providing a plurality of rigidified droplets (e.g., gel droplets) containing a first fluid, substantially surrounded by a second fluid. The plurality of rigidified droplets may be exposed to a third fluid (which may be substantially miscible with the first fluid), and at least one species may be added internally to each droplet.

[0029] The addition of a species to a droplet may be accomplished using any suitable technique. In one embodiment, the species is added to the droplet by allowing the species to diffuse from the fluid substantially surrounding the droplet into fluid contained within the droplet. This may be repeated for a second group of rigidified droplets and a second species. In some cases, at least some of the first group of rigidified droplets and the second group of rigidified droplets may be combined within a common suspension comprising the first and second droplets.

[0030] A non-limiting example of one embodiment of the invention is depicted in FIG. 1. In this figure, a plurality of droplets 4 comprising a first fluid are substantially surrounded by second fluid 2. In some cases, the first fluid and the second fluid may be substantially immiscible such that the plurality of droplets 4 do not coalesce or dissolve with second fluid 2. However, in other cases, as discussed below, the first fluid and the second fluid need not be substantially immiscible. The plurality of droplets 2, in FIG. 1, is caused to undergo a phase change to form a plurality of rigidified droplets 6, as indicated by arrow 3. The phase change may be induced, for example, by altering the temperature of the droplets, by a chemical reaction, or the like. For instance, the droplets may comprise a material such as agarose, which forms a gel when the polymer is cooled to a temperature below its gelling temperature.

[0031] In FIG. 1, the plurality of rigidified droplets 6 is then exposed to a third fluid 8, as indicated by arrow 5. Third fluid 8 may be substantially immiscible with second fluid 2 and/or substantially miscible with the first fluid, although in some cases, as discussed below, these are not requirements. In some cases, for instance, if the plurality of droplets 4 were exposed to third fluid 8 before the phase change described above, droplets 4 may coalesce with third fluid 8, for instance if droplets 4 were aqueous-based, second fluid 2 was oil-based, and third fluid 8 was also aqueous-based. Accordingly, by rigidifying droplets 4, coalescence with third fluid 8 may be avoided or at least reduced in some embodiments.

[0032] In some cases, the rigidified droplets are exposed to a variety of conditions. For instance, the rigidified droplets may be exposed to various species, environmental conditions, or the like. In this example, the rigidified droplets have substantially the same composition, which may be useful in reducing differences due to the production of the droplets themselves, as opposed to the varying conditions the droplets were subsequently exposed to. For instance, referring again to FIG. 1, the plurality of rigidified droplets may be separated into a first group 10 of rigidified droplets 14 and a second group 12 of rigidified droplet 16, as indicated by arrow 7. As shown in FIG. 1, the first group and second group are divided by a partition within the same vessel; however, in other cases, the groups may be contained within separate vessels, or the groups may be separate aliquots or samples, etc. The droplets may also be separated into more than two groups in other embodiments, as discussed below; only two groups are presented in FIG. 1 for reasons of clarity. In this figure, at least one first species 18 is introduced into at least some of first group 10 of rigidified droplets 14 to form a first group 26 of species-containing droplets 22, as follows. First species 18 may be present in third fluid 8 (for example, added to third fluid 8 after separation of first group 10), and is allowed to associate with or be contained internally in the droplet, e.g., via diffusion, chemical reaction, etc. Next, the suspension of droplets may be exposed to a fourth fluid 38. The fourth fluid may or may not be the same fluid as the second fluid, and in some cases, the fourth fluid may be substantially immiscible with the first fluid. In some cases, fourth fluid 32 is chosen such that species 22 is not able to substantially leave droplets 14 to enter fourth fluid 32 (e.g., due to differences in solubility). However, in other cases, e.g., when species 22 is chemically reacted with droplet 14, the fourth fluid need not be one which discourages species 22 from leaving droplets 14, nor be one which is substantially immiscible with the first fluid. Thus, by using an approach such as the one discussed above,

first species 18 may be introduced into rigidified droplets 14 to form a first group 26 of species-containing droplets 22. This process can also be repeated for the second group 12 of rigidified droplets 16 (e.g., at least one second species 20 may be added to at least some of the second group 12 of rigidified droplets 16 to form a second group 28 of species-containing droplets 24).

[0033] In some cases, droplets from one or more of these groups may be combined together, e.g., to form a library. As an example, at least one rigidified droplet from the first group and at least one rigidified droplet for the second group may be combined to form a suspension of rigidified droplets 30, as indicated by arrow 11. Of course, this process can be repeated any number of times, e.g., 3, 4, or more times with different species, e.g., to form a library of droplets containing varying species.

[0034] Optionally, the rigidified droplets 30 (which may contain species such as first species 18 and/or second species 20) may be fluidized to form fluidized droplets 32, as indicated by arrow 13 in FIG. 1. The droplets may be fluidized, for example, by causing the droplets to undergo a phase change, e.g., by the temperature of the droplets, or by a chemical reaction. For instance, rigidified droplets containing agarose may be heated to a temperature above its gelling temperature.

[0035] The rigidified and/or the fluidized droplets may then be manipulated using any suitable technique, depending on the application. For instance, the droplets may be identified, sorted, separated, split, fused or coalesced, mixed, charged, sensed, determined, etc., using various systems and methods such as those disclosed in U.S. patent application Ser. No. 11/024,228, filed Dec. 28, 2004, entitled "Method and Apparatus for Fluid Dispersion," by Stone, et al., published as U.S. Patent Application Publication No. 2005/0172476 on Aug. 11, 2005; U.S. patent application Ser. No. 11/246,911, filed Oct. 7, 2005, entitled "Formation and Control of Fluidic Species," by Link, et al., published as U.S. Patent Application Publication No. 2006/0163385 on Jul. 27, 2006; U.S. patent application Ser. No. 11/885,306, filed Aug. 29, 2007, entitled "Method and Apparatus for Forming Multiple Emulsions," by Weitz, et al.; or U.S. patent application Ser. No. 11/360,845, filed Feb. 23, 2006, entitled "Electronic Control of Fluidic Species," by Link, et al., published as U.S. Patent Application Publication No. 2007/0003442 on Jan. 4, 2007, each incorporated herein by reference.

[0036] As an example, the fluidized droplets shown in the example of FIG. 1 may be fused with droplets 40. As shown in FIG. 1, droplets 34 and droplets 36 may be combined to form a population of droplets 32 (some of which contain first species 18 and some of which contain second species 20, etc.), and the population of droplets are then fused with a plurality of droplets 40, as indicated by arrow 15. As a particular example, in some instances, each of the plurality of droplets 40 comprises at least one analyte molecule 44 that one of first species 18 and second species 20 may be able to interact with. In this example, each of the fused fluidic droplets 48, formed after fusing each of droplets 40 with one of droplets 18 or 20, will comprise at least one analyte molecule 44 and at least one of first species 18 or second species 20.

[0037] The plurality of microfluidic droplets may be analyzed, using a variety of techniques, to determine the at least one analyte. Examples of such techniques include, but are not limited to, those described in U.S. patent application Ser. No. 11/024,228, filed Dec. 28, 2004, entitled "Method and Apparatus for Fluid Dispersion," by Stone, et al., published as U.S.

Patent Application Publication No. 2005/0172476 on Aug. 11, 2005; U.S. patent application Ser. No. 11/246,911, filed Oct. 7, 2005, entitled "Formation and Control of Fluidic Species," by Link, et al., published as U.S. Patent Application Publication No. 2006/0163385 on Jul. 27, 2006; U.S. patent application Ser. No. 11/885,306, filed Aug. 29, 2007, entitled "Method and Apparatus for Forming Multiple Emulsions," by Weitz, et al.; or U.S. patent application Ser. No. 11/360,845, filed Feb. 23, 2006, entitled "Electronic Control of Fluidic Species," by Link, et al., published as U.S. Patent Application Publication No. 2007/0003442 on Jan. 4, 2007, each incorporated herein by reference.

[0038] It should be understood that the present invention is not limited to only the methods described above. In various aspects, various species can be loaded into fluidic droplets, e.g., to form a library of species, and the fluidic droplets can be made rigid or made fluid, for instance, to facilitate loading of species within the droplets, or to manipulate the species contained within the droplets. Accordingly, it should be noted that any combination of the above steps and/or additional steps may be used in the present invention, as discussed herein. For example, a plurality of rigidified droplets may be fused with a plurality of microfluidic droplets without the step of fluidizing the plurality of rigidified droplets. As another example, each group of rigidified droplets may also comprise at least one distinguishable identification element. As yet another example, the plurality of rigidified droplets may be separated into at least about 4096 groups. Each of the steps and/or additional steps are discussed in detail herein, as well as numerous examples of the combination of steps that may be performed.

[0039] In some embodiments of the present invention, a droplet, such as a microfluidic droplet, may be caused to undergo a phase change from a first phase to a second phase, which as mentioned above, may facilitate the loading of a species within the droplet and the like. Non-limiting examples of phases include solid phase, gel phase, liquid phase, gas phase, and the like. For example, a droplet may undergo a phase change from substantially liquid (e.g., the droplet is mostly in a liquid phase) to substantially solid (e.g., the droplet is mostly in a solid phase), or from substantially liquid to a substantially gel phase. It is important to note, however, that a phase change does not necessarily need to be a full change between two phases. For instance, a liquid droplet may be at least partially rigidified to form a rigidified droplet or vice versa.

[0040] A "rigidified droplet," as used herein, is a droplet that is in a state that is not fluid, e.g., the droplet is not in a liquid or gaseous state. For example, a rigidified droplet may be a solid droplet (e.g., a particle), a gel droplet, and the like. Materials that may be used to produce a rigidified or fluidized droplets, as well as methods to induce a phase change of a droplet are discussed more herein. As mentioned, in some cases, a rigidified droplet can be produced by causing a phase change in a fluidic droplet. Non-limiting examples of phase changes of a droplet that is rigidified include substantially gas phase to substantially solid phase, substantially gas phase to substantially gel phase, substantially liquid phase to substantially gel phase, substantially liquid phase to substantially solid phase, or the like. Non-limiting examples of phase changes of a droplet that is fluidized include substantially solid phase to substantially liquid phase, substantially gel phase to substantially liquid phase, or the like.

[0041] As mentioned above, in some embodiments, a species may be internally contained in a rigidified droplet, such as a microfluidic droplet. The species may be contained within the droplet during the initial formation of the droplet, or after the droplet has formed. In one set of embodiments, a droplet is first rigidified, and then exposed to a fluid containing the species. The species may enter the droplet, for example, via diffusion. The species may then be contained within the droplet, for instance, by chemically reacting the species to the droplet, or by replacing the fluid with a second fluid that does not allow the species to substantially leave the droplet (e.g., due to a difference in hydrophobicity or hydrophilicity).

[0042] The following discussion gives non-limiting examples of methods to add at least one species to a rigidified droplet. In other cases, the species may be added to the droplet by injecting the species into the droplet. In yet another case, the species may be a part of the first fluid, such that the species is present in the droplet (e.g., in the fluid) before the droplet is formed, rigidified and/or fluidized. Other methods and techniques for internally containing a species in a rigidified droplet will be known to those of ordinary skill in the art. In some embodiments, exposing a droplet to a fluid comprising a plurality of species may cause at least one species to be contained internally in the droplet. This may be achieved, in some cases, when the first fluid contained in the droplet and second fluid substantially surrounding the droplet are substantially miscible, and the second fluid comprises a plurality of a type of species. At least a portion of the fluid contained in the droplet and the fluid surrounding the droplet may exchange and cause at least one species to be contained internally within the first droplet.

[0043] Without wishing to be bound by theory, the substantial miscibility of the first fluid contained in the droplets and the second fluid surrounding the droplet may allow for this exchange in some cases. For example, when second fluid comprising at least one species is exchanged with at least some of the first fluid contained in the droplet, species comprised within the second fluid may also be transferred and contained internally within the droplet. In embodiments where the first fluid comprised within the rigidified droplet and the fluid surrounding the droplet are substantially immiscible, the first fluid contained within the droplet may not substantially exchange with the fluid substantially surrounding the droplet.

[0044] A non-limiting illustration of this exchange is depicted in FIG. 2. In FIG. 2A, a rigidified droplet 50 containing a first fluid is substantially surrounded by second fluid 52 comprising a plurality of species 54. First fluid 50 and second fluid 52 are substantially miscible in this example, and fluid exchange between the rigidified droplet and the second fluid may occur, as indicated by arrow 56. At least one of plurality of species 58 may be transferred into rigidified droplet 50 during the fluid exchange and the fluid surrounding the droplet 60 will now comprise the second fluid and at least some of the first fluid that was contained in the rigidified droplet 50. As another example, as shown in FIG. 2B, a rigidified droplet 62 containing a first fluid is substantially surrounded by second fluid 69 comprising a plurality of species 66. First fluid 60 and second fluid 62 are substantially immiscible and fluid exchange does not occur between the rigidified droplet and the second fluid, as indicated the cross through arrow 64.

[0045] A rigidified droplet comprising a first fluid and surrounded by a second fluid, may be exposed to a third fluid (e.g., comprising a plurality of a type of species) using any technique known to those of ordinary skill in the art. For example, the rigidified droplet may be removed from the second fluid and transferred to the third fluid, as depicted in FIG. 6A. In this figure, rigidified droplet **200** is substantially surrounded by second fluid **202**. The rigidified droplet may be removed (e.g., removed using a pipette, tweezers, a spoon, vacuum, etc.) from second fluid **202**, as indicated by arrow **201**. Rigidified droplet **200** may then be added to third fluid **204**, as indicated by arrow **203**.

[0046] As another example, a third fluid may be added to the second fluid, and in instances where the second fluid and the third fluid are substantially immiscible, the third fluid and the second fluid may form one or more layers. The rigidified droplet may then be substantially surrounded the third fluid. An example of this process for replacing the second fluid with a third fluid is depicted in FIG. 6B. Rigidified droplet **206** is substantially surrounded by second fluid **208**. Third fluid **210** may be added to second fluid **208**. If second fluid **208** and third fluid **210** are substantially immiscible, third fluid **210** will form a layer above (as indicated by arrow **205**) or below second fluid **208** (not shown). Rigidified droplet **206** may then be substantially surrounded by fluid **210**, as indicated by arrow **207**. The second and/or third fluid may be agitated (e.g., stirred, centrifuged, etc.) to aid in the exposure of the rigidified droplet to the third fluid.

[0047] In yet another example, the second fluid may be removed from substantially surrounding the droplets (e.g., evaporation of the second fluid, aspiration or decanting of the second fluid, etc.), as depicted in FIG. 6C. Rigidified droplet **212** is substantially surrounded by second fluid **214** in this example. Second fluid **214** is then removed (e.g., draining of the second fluid) from substantially surrounding the rigidified droplet, as indicated by arrow **213**. Third fluid **218** can then be provided and substantially surround rigidified droplet **212**, as indicated by arrow **215**. In some cases, the rigidified droplets may move into the third fluid, e.g., via gravity or differences in buoyancy.

[0048] In some embodiment, after a species has been contained internally in a rigidified droplet, the species may be immobilized relative to the rigidified droplet. Those of ordinary skill in the art will be aware of methods to immobilize a species with respect to a composition (e.g., gel, polymer) of a rigidified droplet. The species may be immobilized with respect to the composition of the droplet either directly (e.g., formation of a bond, such as a covalent bond) or indirectly (e.g., using a crosslinking molecule). In some instances, application of light or heat to a rigidified droplet internally containing a species may cause the species to become immobilized relative to the rigidified droplet. As another example, the species may be immobilized by exposure to an immobilizing agent (e.g., a chemical compound).

[0049] In some cases, more than one species of a single type will be contained internally in a rigidified droplet. For example, at least about 2 species, at least about 3 species, at least about 5 species, at least about 10 species, at least about 20 species, at least about 50 species, at least about 100 species, and the like, may be added to a rigidified droplet. In some instances, more than one type of species will be contained in the rigidified droplet. That is, at least one of a first type of species and at least one of a second type of species may be added to a rigidified droplet. This may be accomplished, for

example, using the above techniques, where the fluid substantially surrounding the droplet (which may be substantially miscible with the fluid contained within the droplet) comprises a plurality of the first type of species and a plurality of the second type of species. The total number of a species in each of a plurality of droplets may or may not necessarily be equal. For example, a first droplet in a plurality of droplets may comprise only one species of a single type and second droplet in the plurality of droplets may comprise more than one species of a single type.

[0050] In some cases, a rigidified droplet may comprise at least about 2 types, at least about 3 types, at least about 4 types, at least about 5 types, at least about 6 types, at least about 8 types, at least about 10 types, at least about 15 types, at least about 20 types, or the like, of species. The total number of species of each type contained within the droplet may or may not necessarily be equal. For instance, in some cases, when two types of species are contained within a droplet, there may be approximately an equal number of the first type of species and the second type of species contained within the rigidified droplet. In other cases, the first type of species may be present in a greater or lesser amount than the second type of species, for example, the ratio of one species to another species may be about 1:2, about 1:3, about 1:4, about 1:5, about 1:6, about 1:10, about 1:20, about 1:100, and the like. The number of species of each type of species in each of a plurality of droplets in a group may or may not be equal. For example, a first droplet of a group may comprise one species of a first type and one species of a second type where a second droplet of the group may contain more than one species of the first type and one or more species of the second type.

[0051] The species may or may not be substantially soluble in the fluid contain in the droplet and/or the fluid substantially surrounding the droplet. For example, in some cases, a species may be substantially soluble in a second fluid substantially surrounding a droplet and in a first fluid contained within a droplet. In other cases, the species is substantially soluble in the second fluid and substantially insoluble in the first fluid, such that the species may precipitate when contained in the droplet. In yet other cases, the species is substantially insoluble in both the second fluid and the first fluid, and is suspended in the fluids.

[0052] The methods for forming a plurality of species-containing droplets and/or a suspension of rigidified species-containing droplets may be, in some embodiments of the present invention, applied to creating libraries of droplets containing various species. For example, in some embodiments, a plurality of rigidified droplets may be separated into at least a first group and at least a second group of rigidified droplets, where a distinguishable type of species may be contained internally in at least some of each group of droplets. At least one droplet from each group may be combined to form a plurality of droplets, each comprising at least one distinguishable species (e.g., a library of droplets). That is, at least one first species and one least second species may be added to at least a portion of the first group and the second group of rigidified droplets, respectively, and at least one droplet from each group may be combined to form a suspension of rigidified droplets (e.g., a library). Addition of a species to a droplet may be accomplished using any of the techniques discussed herein. In a particular embodiment, a first group of droplets and a second group of droplets are exposed to a first fluid and a second fluid comprising a plurality of a first species and a second species, respectively. The plurality

of rigidified droplets may be separated into at least about 2 groups, at least about 4 groups, at least about 10 groups, at least about 30 groups, at least about 50 groups, at least about 64 groups, at least about 128 groups, at least about 1024 groups, at least about 4096 groups, at least about 10,000 groups, and the like. The number of groups the plurality of droplets is separated into may be selected such that the number is approximately equal to the total number of types of distinguishable species to be added to the droplets.

[0053] In some embodiments, a suspension may be formed that comprises at least a portion of each group of rigidified droplets. For example, a portion of a first group and of a second group of rigidified droplets may be suspended in a fluid. The first and second groups of rigidified droplets may be combined into a common suspension of the first and second groups of droplets using any known technique. For example, a first fluid comprising the first group of rigidified droplets and the second fluid comprising the second group of rigidified droplets may combine to form a third fluid (e.g., comprising the first and the second fluids) comprising the first group and the second group of rigidified droplets. In some cases, only a portion of the first fluid comprising a portion of the first group of rigidified droplets will be combined with a portion of the second fluid comprising a portion of the second group of rigidified droplets. The first fluid and the second fluid may or may not comprise substantially the same make-up. In certain aspects, the first fluid and the second fluid will be miscible. In some cases, the suspension of rigidified droplets may be exposed to a third fluid using the techniques discussed here (e.g., see FIG. 6).

[0054] A suspension of rigidified droplets (e.g., a library of rigidified droplets) may be stored for any length of time. In some cases, the suspension of rigidified droplets may be stored such that the species contained within each droplet does not substantially change. That is, the species contained within each droplet do not diffuse from the droplet and/or new species are not contained internally in the droplet. Without wishing to be bound by theory, this aspect of the invention may be important during the formation of a library comprising labels. For example, if a label contained in a first droplet is able to exchange with a label contained in a second droplet, where the labels are each associated with a particular species in a library, the labels would be rendered useless in determining the species of the library contained in the droplet if exchange is possible. For example, at least about 100%, at least about 99.5%, at least about 99%, at least about 98%, at least about 97%, at least about 96%, at least about 95%, at least about 90%, at least about 85%, at least about 80%, and the like, of the plurality of rigidified droplets contained in the suspension may contain the same species after storage as they did prior to storage. The suspension of the droplets may be stored without substantial change for at least about 1 day, at least about 2 days, at least about 5 days, at least about 10 days, at least about 1 month, at least about six months, at least about 1 year, at least about 2 years, at least about 5 years, and the like.

[0055] Prior to forming the suspension of droplets, in some embodiments, a group of droplets containing at least one species may be exposed to a fluid which does not comprise any species. Without wishing to be bound by theory, exposure of the group of rigidified droplets containing a species to a fluid which is substantially immiscible with the droplets may prevent the species contained within the droplet from being transferred to the fluid surrounding the droplets through fluid

exchange (e.g., because the fluids are not miscible, the exchange of the two fluids will be little or none). For example, a group of rigidified droplets containing at least one species and a first fluid may be exposed to a second fluid that does not comprise a plurality of species, where the first fluid and the second fluid are substantially immiscible. The immiscibility of the first fluid with the second fluid may not allow for the species contained in the droplet to diffuse into the second fluid. In other instances, when the species are immobilized relative to the droplet, the group of rigidified droplets may be exposed to a fluid which is substantially immiscible or substantially miscible with the fluid contained in the droplet since the species are immobilized relative to the droplet, the species may not be able to diffuse into the fluid substantially surrounding the droplet.

[0056] In some embodiments, a plurality of microfluidic droplets may be formed, where each of the microfluidic droplets comprises at least one species-containing rigidified or fluidized droplet (e.g., from a library of droplets) and in some cases, at least one target analyte molecule. Within the microfluidic droplet, the target analyte molecule may interact with a species for the species-containing droplets, and in some cases, the interaction may be determined. In instances where the species-containing droplets are fluidized, the fluidized droplet and the analyte droplet may be fused to form a single droplet containing the fluids from both droplets. This may occur if the fluid within the analyte droplet and the fluid in the fluidized droplet are substantially miscible. In instances where the species-containing droplet is rigidified, the rigidified droplet may be contained within the analyte droplet. A plurality of rigidified droplets may be fluidized using the methods and techniques discussed herein.

[0057] In some cases, a plurality of microfluidic droplets (e.g., fused droplets) may be formed by fusing at least a portion of a plurality of species-containing droplets (e.g., a library of droplets) with a plurality of analyte droplets containing analyte molecules. An "analyte droplet" is a droplet which contains at least one fluid and at least one target analyte molecule. The plurality of species-containing droplets may be rigid or fluidic. At least a portion of the species-containing droplets (either rigidified or fluidized) may be fused with a plurality of analyte droplets using microfluidic techniques, such as those described in U.S. patent application Ser. No. 11/024,228, filed Dec. 28, 2004, entitled "Method and Apparatus for Fluid Dispersion," by Stone, et al., published as U.S. Patent Application Publication No. 2005/0172476 on Aug. 11, 2005; U.S. patent application Ser. No. 11/246,911, filed Oct. 7, 2005, entitled "Formation and Control of Fluidic Species," by Link, et al., published as U.S. Patent Application Publication No. 2006/0163385 on Jul. 27, 2006; U.S. patent application Ser. No. 11/885,306, filed Aug. 29, 2007, entitled "Method and Apparatus for Forming Multiple Emulsions," by Weitz, et al.; or U.S. patent application Ser. No. 11/360,845, filed Feb. 23, 2006, entitled "Electronic Control of Fluidic Species," by Link, et al., published as U.S. Patent Application Publication No. 2007/0003442 on Jan. 4, 2007, each incorporated herein by reference.

[0058] In some cases, a plurality of fluidized species-containing droplets are fused with a plurality of analyte droplets. The fluid contained within the analyte droplet and the fluid contained within the suspensions of droplets, in most cases, may be substantially miscible. This may, in cases where the plurality of species-containing droplets are fluidized, allow for essentially complete fusion of a fluidized droplet with the

analyte droplet, such that the fused microfluidic droplet formed contains the species from the fluidized droplet and the target analyte molecule. For example, as shown in FIG. 3A, fluidized droplet **100** from the suspension containing species **102** and analyte droplet **104** containing a target analyte molecule **106** are fused, as indicated by arrow **107**, to form fused fluidic droplet **108** comprising species **102** and target analyte molecule **106**.

[0059] In other cases, the suspension of rigidified species-containing droplets are fused with a plurality of analyte droplets to form a plurality of fused microfluidic droplets. In some aspects of this embodiment, the fluid contained in the rigidified droplets may be substantially miscible with the fluid contained in the analyte droplet and may allow for the species contained within the rigidified droplet to diffuse from the rigidified droplet into the fluid of the fused microfluidic droplet, or for the target analyte molecule to be contained internally in the rigidified droplet, thus allowing the target analyte molecule and the species to interact. As a non-limiting example, as shown in FIG. 3B, species-containing rigidified droplet **110** containing species **112** and analyte droplet **114** containing target analyte molecule **116** are fused, as indicated by arrow **107**, such that the fused microfluidic droplet formed **118** contains target analyte molecule **116** and rigidified droplet **120** containing species **112**. The miscibility of the fluid contained in fused microfluidic droplet **118** and rigidified droplet **120** may allow for the exchange of fluid, as indicated by arrow **122**. This may allow for species **116** to diffuse into the fluid of the fused droplet **124** from rigidified droplet **126**, as indicated by arrow **121**. In other aspects, at least a portion of the species contained in the rigidified droplet may remain contained internally in the rigidified droplet while interacting with the target analyte molecule.

[0060] In yet another embodiment, a plurality of species-containing rigidified droplets in which the species have been immobilized relative to a rigidified droplet may be fused with a plurality of analyte droplets. The interaction between the target analyte molecule and the species immobilized relative to a rigidified droplet may be determined. In such instances, the target analyte molecule may be substantially soluble in the fluid substantially surrounding the plurality of rigidified droplets. In addition, the fluid comprised in the rigidified droplets may be substantially miscible with the fluid substantially surrounding the droplets. Without wishing to be bound by theory, this property should allow for the target analyte molecule to diffuse into the rigidified droplet, thereby interacting with the species immobilized in the rigidified droplet.

[0061] In still yet another embodiment, a plurality of microfluidic droplets may be formed using microfluidic techniques from a solution comprising a fluid, a suspension of rigidified species-containing droplets, and a plurality of target analyte molecules. For example, the plurality of target analyte molecules may be provided to the fluid substantially surrounding the plurality of rigidified droplets. Using microfluidic techniques, the fluid may be dispersed into droplets, where the dispersed droplets may comprise a target analyte molecule and/or a rigidified droplet. This non-limiting example is depicted in FIG. 3C. Fluid **128** is provided comprising a plurality of target analyte molecules **134** and a plurality of rigidified droplets **130** internally containing species **132**. The continuous stream of fluid **128** may flow into microfluidic channel **138** comprising second fluid **136** to form a plurality of microfluidic droplets **140**, a technique that will be well known to those commonly skilled in the art.

[0062] It should be understood when using the various embodiments discussed above, not every microfluidic droplet formed will comprise a rigidified or fluidized droplet and a target analyte molecule. Some droplets formed may contain neither a rigidified or fluidized droplet nor a target analyte molecule, some droplets formed may contain only one of the two, and some droplets formed may contain both. This by no means limits the applications of the droplets formed. Additional methods for forming a plurality and/or suspension of rigidified droplets are now described.

[0063] In one embodiment of the present invention, a method for forming a plurality of species-containing rigidified droplets comprising first providing a plurality of droplets, each of the plurality of droplets comprising a first fluid and being substantially surrounded by a second fluid, where the first fluid and the second fluid are substantially immiscible. The plurality of droplets may undergo a phase change to form a plurality of rigidified droplets (e.g., gel droplets). The plurality of rigidified droplets may be exposed to a third fluid, which may, in some cases, be substantially miscible with the first fluid contained in the rigidified droplets. At least one first species may be added internally to at least some of the rigidified droplets (e.g., by diffusion of a fluid containing the species into the droplet).

[0064] A non-limiting example of the above method is depicted in FIG. 4. A plurality of droplets **150** comprising a first fluid are substantially surrounded by a second fluid **152**, where the first fluid and the second fluid are substantially immiscible. The plurality of droplets undergo a phase change, as indicated by arrow **151**, to form a plurality of rigidified droplets **154**, which are substantially surrounded by second fluid **152**. The plurality of rigidified droplets **154** are exposed to a third fluid **156**, where the first fluid comprised in the plurality of rigidified droplets **154** is substantially miscible with third fluid **156**, as indicated by arrow **155**. At least one first species **158** is added to each rigidified droplet **160**, as indicated by arrow **157**.

[0065] As another embodiment, a method to form a plurality of species-containing droplets may comprise the following steps. First, a plurality of groups of rigidified droplets may be provided. Each of groups of rigidified droplets may have substantially the same composition as the other groups of rigidified droplets, where each group of droplet contains the same first fluid and at least one distinguishable species with respect to the other groups of rigidified droplets. A suspension may be formed which contains at least one rigidified droplet from each of the groups of rigidified droplets. At least some of the suspension of droplets, in some cases, may be exposed to a second fluid, where the second fluid is substantially immiscible with the first fluid. Exposure of the rigidified droplets to a second fluid which is substantially immiscible with the first fluid contained in the droplets may allow for at least some of the droplets to be fluidized such that the droplets do not coalesce with the fluid surrounding the droplets.

[0066] A non-limiting example is illustrated in FIG. 5. In this example, three groups of rigidified droplets (**172**, **176**, **178**) are provided, each droplet comprising a first fluid and at least one type of species (**172**, **178**, **184**, respectively), where each of the types of species are distinguishable with respect to the others species. Each of the groups of rigidified droplets are substantially surrounded by a second fluid (**174**, **180**, **186**), where the first fluids and the second fluids are substantially immiscible. Each of the groups of droplets have substantially the same make-up (e.g., each of the droplets con-

sists essentially of the same material). The second fluid surrounding each of the groups of rigidified droplets may be the same or different fluid. A suspension **186** is formed which comprises at least one rigidified droplet from each of the three groups of droplets (**171**, **177**, **183**) suspended in fluid **184**, as indicated by arrow **173**. The suspension of droplets **186** may be exposed to a third fluid **188**, as indicated by arrow **175**. The suspension of droplets may then be fluidized, as indicated by arrow **179**, to form a plurality of fluidized droplets **196** comprising a fluidized droplet from each group (**190**, **192**, **194**), each comprising a distinguishable species (**172**, **178**, **184**).

[0067] In yet another embodiment, the present invention provides a method for forming a suspension of species-containing droplets comprising at least one droplets from each of a first group of rigidified droplets and a second group of rigidified droplets, where the first group of rigidified droplets contains a first species which is distinguishable from the second species contained in the second group of rigidified droplets. The method may first provide a first plurality of rigidified droplets containing a first fluid, where each rigidified droplet is substantially surrounded by a second fluid which is substantially immiscible in the first fluid. The first plurality of rigidified droplets may be exposed to a third fluid, where the third fluid is substantially miscible in the first fluid. At least one first species may be added internally to at least some of the first plurality of rigidified droplets to form a first group of species-containing droplet. The above steps may be repeated with a second plurality of rigidified droplets and a second species to form a second group of species-containing droplets. A suspension may be then formed which contains at least some droplets of the first and second groups of species-containing droplets.

[0068] An example of the above is depicted in FIG. 8. A first plurality of rigidified droplets **240** comprising a first fluid is provided, where each of the rigidified droplets is substantially surrounded by a second fluid **242**. The first plurality of rigidified droplets **240** are exposed to a third fluid **244**, as indicated by arrow **241**. A least one first species **248** is added to at least some of the first plurality of rigidified droplets to form a first group of species-containing droplets **248**, as indicated by arrow **243**. These series of steps **248** are performed with a second plurality of rigidified droplets **250**, thereby forming a second plurality of species-containing droplets **254** comprising a second species **252**, where first species **248** and second species **252** are distinguishable with respect to each other. A suspension **256** is then formed comprising at least one first species-containing droplet **246** and at least one second-species containing droplet **252**, as indicated by arrow **245**.

[0069] As mentioned above, the methods for forming a plurality of species-containing droplets and/or a suspension of rigidified species-containing droplets may be, in some embodiments of the present invention, applied to creating libraries of droplets containing various species. A library may contain droplets that are all substantially the same size and have substantially the same composition, but differ in the species contained within the droplets. For instance, a first member of a library may be a collection of droplets containing a first species, and a second member of a library may be a collection of droplets containing a second species, the first species at a different concentration, a first species and a second species, or the like. Such libraries may be useful, for example, for nucleic acid sequencing applications, screening assays, or the like.

[0070] In some cases, the library includes compositions comprising a container comprising a plurality of mutually distinguishable rigidified droplets, each having substantially the same composition but containing a distinguishable species with respect to the other rigidified droplets. In some cases, the composition is produced using the methods discussed herein. The composition may comprise at least about 5, at least about 8, at least about 10, at least about 20, at least about 50, at least about 64, at least about 100, at least about 128, at least about 200, at least about 500, at least about 1000, at least about 4096, at least about 10,000, at least about 50,000, and the like, mutually distinguishable species. The substantially same composition of the rigidified droplets may comprise a polymer and/or gel.

[0071] The composition and methods of the present invention may be useful for the sequencing of a target nucleic acid. For example, the target analyte molecule may be a nucleic acid and the species may be selected from a library of nucleic acid probes, such that the sequence of the nucleic acid may be determined. Other target analyte molecules that can be studied include, for example, biochemical species such as nucleic acids such as siRNA, RNAi and DNA, proteins, peptides, or enzymes. It should be understood, however, that while the discussion herein primarily focuses on the use of droplets of the present invention for sequencing a nucleic acid, this is by way of example only, and the droplets have many other uses, such as techniques relating to fields such as food and beverages, health and beauty aids, paints and coatings, and drugs and drug delivery. For example, in some instances, a target analyte molecule may be a cell, and the interaction of the cell with a variety of species (e.g., drugs, hormones, etc.) may be determined. Species that can be incorporated within droplets of the invention include, but are not limited to, nucleic acid probes, nanoparticles, quantum dots, fragrances, proteins, indicators, dyes, fluorescent species, chemicals, or the like. A droplet or emulsion can also serve as a reaction vessel in certain cases, such as for controlling chemical reactions, or for in vitro transcription and translation, e.g., for directed evolution technology. In addition, droplets of the present invention may comprise additional reaction components, for example, catalysts, enzymes, inhibitors, and the like.

[0072] In some embodiments, the target analyte molecule may be a target nucleic acid to be sequenced, where the target nucleic acid may be any suitable nucleic acid. For example, the target nucleic acid may be a nucleic acid that encodes a biological entity, such as a protein, an enzyme, an antibody, a receptor, a ribozyme, a ribosome, or the like, and/or a portion thereof. As another example, the target nucleic acid may be a regulatory sequence or a non-coding sequence, for instance, a small interfering RNA, a microRNA, a small hairpin RNA, or the like. The target nucleic acid can be any number of nucleotides in length, for example, on the order of 25, 50, 60, 64, 70, 80, 90, 100, 200, 400, 800, 1600, 3200, 6400, or even more nucleotides in length. Non-limiting examples of target nucleic acids include ribonucleic acid (RNA), deoxyribonucleic acid (DNA), or mixtures or copolymers thereof, which may be isolated from natural sources, recombinantly produced, artificially synthesized, etc. The nucleic acid may contain residues such as adenosine or "A," thymidine or "T," guanosine or "G," cytidine or "C," or uridine or "U," or other residues, such as the universal residues. The nucleic acid can be double-stranded or single stranded to facilitate hybridization. Moreover, the nucleic acid can be obtained from virtually any source. For instance, the nucleic acid may be isolated

from a cell or a virus, synthesized using traditional chemical synthesis, synthesized using polymerase chain reaction (PCR) technology, or the like.

[0073] The target nucleic acid contained within the droplet may be exposed to a nucleic acid probe and/or one or more identification elements. For instance, as previously discussed, an analyte droplet comprising at least one target analyte molecule (e.g., a target nucleic acid) may be fused with a species-containing droplet (e.g., a nucleic acid probe) and in most cases, at least one identification element for determining the nucleic acid probe. The fluidic droplets may be used for sequencing a nucleic acid using techniques such as those disclosed in U.S. Patent Application Ser. No. 61/008,862, filed Dec. 21, 2007, entitled "Systems and Methods for Nucleic Acid Sequencing," by Weitz, et al, herein incorporated by reference.

[0074] The suspension of droplets (either fluidized or rigidified) may comprise a plurality of group of droplets, where each group of droplet internally contains at least one nucleic acid probe. Nucleic acid probes are generally used, in certain embodiments, to determine certain sequences within the target nucleic acid. Often, short portions of the target nucleic acid can be associated with the nucleic acid probe, for instance, a sequence of less than 20 residues, less than 15 residues, less than 10 residues, less than 9 residues, less than 8 residues, less than 7 residues, less than 6 residues, less than 5 residues, less than 4 residues, etc. The residues are typically contiguous within the target nucleic acid probe although, in some cases, some of the residues within the target nucleic acid are not necessarily contiguous. In some embodiments, a nucleic acid probe may contain a relatively short sequence of nucleic acid residues that is able to recognize at least a portion of the target nucleic acid, and often has a similar length as the recognized portion of the target nucleic acid. For instance, the nucleic acid probe may have a sequence having length of less than 20 nucleotides or less than 10 nucleotides in some cases, or a length such as those described above. In one case, the length of the nucleic acid probe sequence may be four residues (e.g., FIG. 7A). In another case, the length may be five residues (e.g., FIG. 7B). In yet another case, the length may be six residues (e.g., FIG. 7C). The nucleic acid probe sequences within the nucleic acid probe may be contiguous, or the sequence may be non-contiguous. For instance, there may be universal residues or gaps present. In some instances, the nucleic acid probe may be labeled in some manner, such as with a signaling entity, for instance, a radioisotope or with a fluorescence tag (e.g., FIG. 7D). Various signaling entities and other examples of nucleic acid probes will be discussed in more detail below.

[0075] The nucleic acid probe may be selected such that at least some of the probes will contain sequences complementary or substantially complementary to the target nucleic acid sequence. For instance, in one embodiment, the nucleic acid probe sequences are selected such that every permutation of nucleic acid residues of a certain size or number (or range of sizes or numbers) is represented, thereby ensuring that at least one of those nucleic acid probe sequences is substantially complementary to the target nucleic acid. As used herein, a first sequence that is "substantially complementary" to a second sequence is one which at least about 75% of the first and second sequences are complementary (e.g., through Watson-Crick complementarity pairing) and/or the sequences have a maximum of 1 or 2 base mismatches. In some embodiments, the two sequences may be at least about 80%, at least about

85%, at least about 90%, at least about 95%, at least about 97%, at least about 98%, at least about 99% or at least about 100% complementary.

[0076] In some embodiments, a plurality of distinguishable or non-identical nucleic acid probes is used, for example, nucleic acid probes having one or more differences in the sequence of residues contained within the nucleic acid probes. For instance, a plurality of fluidized or rigidified droplets may be used, and the droplets may each contain a specific nucleic acid probe sequence. The droplets may be prepared such that each droplet contains only one nucleic acid probe sequence (although multiple copies of the nucleic acid probe may be present). In addition, in some cases, different droplets may independently contain the same or different nucleic acid probe sequence (e.g., such that there is some redundancy so that not each droplet in a given population or collection of droplets is necessarily unique).

[0077] In some cases, the nucleic acid probe may be labeled, e.g., with a signaling entity. The signaling entity may be determined in some fashion using a detection method, such as those discussed herein. The signaling entity may be included within the nucleic acid probe at any suitable location, for example, at a 5' terminal site of the nucleic acid sequence of the nucleic acid probe, a 3' terminal site, or at an internal site within the nucleic acid probe. In some cases, the signaling entity may be chosen such that it produces a different signal (or does not produce a signal) when the nucleic acid probe is associated with a target nucleic acid compared to when the nucleic acid probe is not associated with the target nucleic acid. The signaling entity may include, but is not limited to, a fluorescent dye, a chemiluminescent entity, a radioactive label, an isotope such as a non-radioactive isotope or an isotope detectable by mass spectrometry (e.g., an electrophore mass label (EML)), a ligand which can serve as a specific binding partner to a labeled antibody, an enzyme, an antibody which can serve as a specific binding partner for a labeled ligand, an antigen, a group having a specific reactivity, and/or an electrochemically detectable moieties. Non-limiting examples of fluorescent signaling entities include fluorescein, rhodamine, or hexachlorofluorescein; those of ordinary skill in the art will be aware of other fluorescent entities that are readily commercially available. Yet other examples of signaling entities are discussed in detail herein.

[0078] For instance, in one embodiment, a nucleic acid probe can include a sequence of nucleic acid residues, a signaling entity, and a quencher or an enhancer (e.g., as is shown in FIG. 7E, with the signaling probe labeled S and a quencher labeled Q). The signaling entity may be, e.g., a fluorescent entity, and may be located anywhere in the nucleic acid probe, for instance, covalently attached to the 5' end of the nucleic acid sequence. Non-limiting examples of fluorescent entities potentially suitable for use in the nucleic acid probe in various embodiments include 6-carboxyfluorescein and tetraethylrhodamine. The quencher or enhancer may be any entity able to affect the signaling entity in some fashion, e.g., by respectively inhibiting or facilitating determination of the signaling entity. For instance, the proximity of a fluorescent signaling entity and a quencher within a nucleic acid probe may be such that the quencher is able to partially or completely inhibit fluorescence of the signaling entity, while an enhancer may be able to enhance the fluorescence of a fluorescent signaling entity when the enhancer is positioned proximate the signaling entity. The quencher or enhancer may also be located anywhere in the nucleic acid probe, for

example, attached to the 3' end of the nucleic acid sequence. Non-limiting examples of quenchers include tetramethylrhodamine and dihydrocyclopyrroloindole tripeptide.

[0079] As a non-limiting example, a quencher (or similarly, an enhancer) can be used within a signaling entity in a nucleic acid probe as follows. A nucleic acid probe associated with a target nucleic acid may be removed or dissociated from the target nucleic acid by the action of certain enzymes or other species, for instance, polymerases such as Taq polymerases. For instance, in some cases, a polymerase may cause degradation of the nucleic acid sequence within the nucleic acid probe to occur, which may cause release of the signaling entity and/or the quencher or enhancer and hence, the quencher or enhancer may no longer be proximate to or at least substantially affect the signaling entity. Thus, degradation of the nucleic acid probe can be determined by determining a change in the signaling entity. In contrast, in systems where the nucleic acid probe does not sufficiently associate with the target nucleic acid (e.g., if no sufficiently complementary sequences are present), no degradation of the nucleic acid probe would occur through action of the polymerase or other species (e.g., any association that exists between the target nucleic acid and the nucleic acid probe is too transient or short for enzymatic action to occur), and thus, no significant change in the signal of the signaling entity could be determined. Accordingly, in one embodiment, a polymerase such as Taq polymerase may be provided to a fluidic droplet comprising a nucleic acid probe and a target nucleic acid. The polymerase may be provided to the fluidic droplet using any suitable technique, as discussed herein.

[0080] In some cases, a nucleic acid probe may comprise at least one locked nucleic acid (LNA) residue (see, e.g., FIG. 7F). A locked nucleic acid residue is a nucleic acid analog that has a chemical shape similar to a naturally occurring nucleic acid residue (e.g., being able to form 2 or 3 hydrogen bonds with a complementary residue), but is not free to rotate in as many dimensions as a naturally occurring nucleic acid residue. For instance, in some cases, a locked nucleic acid residue may contain a 2'-O,4'-C methylene bridge, where the methylene bridge "locks" the ribose in the 3'-endo structural conformation, which is often found in the certain form of DNA or RNA. The locked ribose conformation may enhance residue stacking and/or backbone pre-organization. This can significantly increase the thermal stability (melting temperature) of the nucleic acid sequence in some cases. A nucleic acid probe containing one or more locked nucleic acid residues may be useful in certain embodiments because the locked nucleic acid residue may exhibit increased affinity for association with the target nucleic acid, e.g., due to the restrictions on its ability to internally rotate.

[0081] In certain embodiments, the nucleic acid probe may contain a universal residue, which may be able to engage in a residue-pairing relationship with more than one natural nucleotide, and in some cases, with all of the natural nucleotides. Exemplary universal residues include 5-nitroindole and 3-nitropyrrole, although other universal residues useful for the systems and methods described herein will be known to those of skill in the art. As discussed below, a nucleic acid probe containing one or more universal bases may be useful in certain embodiments.

[0082] The nucleic acid probes may be synthesized using any suitable technique, e.g., solid phase phosphoramidite triester methods. In some cases, a plurality of nucleic acid probes is synthesized, forming a library of such probes. The

library may include a plurality of sequences, for example, organized in a plurality of droplets. In some (but not all) embodiments, the library may contain sequences that have roughly the same number of residues, for example, around 4 residues, around 5 residues, around 6 residues, around 7 residues, etc. The library of nucleic acid probes may be prepared using any suitable technique, and may be produced using manual techniques or automated, e.g., using a robotic apparatus.

[0083] In one embodiment, the library may comprise every possible sequence for a set of nucleic acid sequences having a certain length or lengths. In another embodiment, the library may comprise at least about 30%, at least about 50%, at least about 80%, at least about 85%, at least about 90%, at least about 95%, or at least about 100% of all possible sequences having a certain length or lengths. Some techniques for preparing a library are discussed below.

[0084] The library of nucleic acid probes (or any other species) may be internally contained within droplets of the present invention using any suitable technique, as discussed herein. For example, a plurality of rigidified droplets may be produced microfluidically, such that the plurality of rigidified droplets have substantially the same composition as all other droplets of the present invention. A library of nucleic acid probes may be provided (e.g., prepared on a microtiter plate using a robotic apparatus), where each type of distinguishable nucleic acid probe is kept separate from all other types nucleic acid probes. A plurality of rigidified droplets may be separated into approximately the same number of groups as there is types of nucleic acid probes, and each group of rigidified droplets may be exposed to one type of nucleic acid probe, such that at least one of each type of nucleic acid probe is contained internally in a rigidified droplet, forming a plurality of groups of distinguishable droplets (e.g., each group containing a distinguishable nucleic acid probe). At least one of each type of rigidified droplet containing internally a distinguishable nucleic acid probe may be combined to form a suspension of rigidified droplets.

[0085] In many embodiments, at least one identification element may also be contained internally in each group of fluidized or rigidified droplets. An "identification element" as used herein, is a species that includes a component that can be determined in some fashion, e.g., the identification element may be identified when contained within a droplet. The identification elements may be insoluble (e.g., suspended) or soluble within the droplet. Non-limiting examples include identification elements detectable by fluorescence, chemiluminescence, radioactivity, or the like. Specific examples include, but are not limited to, particles containing dyes, quantum dots, or fluorescent particles which, in some embodiments, may also have other species attached thereto, for instance, oligonucleotides such as those described herein. In some cases, more than one identical identification element may be present within any given droplet.

[0086] In certain embodiments, more than one non-identical identification element may be used, e.g., within a droplet. For instance, a droplet may contain at least two distinguishable identification elements, at least three distinguishable identification elements, at least four distinguishable identification elements, at least five distinguishable identification elements, etc. Identification elements may be distinguished using any suitable method, e.g., color, fluorescence, absorption, intensity, size, charge, radioactivity, mass, or the like.

[0087] In one set of embodiments, particles or microparticles (e.g., beads) may be used as identification elements. The particles may have any dimension, and may be spherical or non-spherical. For instance, the particles may have average diameters ranging from approximately 100 nm to 100 μ m in diameter in some cases. In certain embodiments, the particles may have an average diameter of less than about 1 micrometer, less than about 300 nm, less than about 100 nm, less than about 30 nm, or less than about 10 nm. The average diameter, as used herein, is the arithmetic average of the diameters of the particles contained within the droplets. The diameters of a non-spherical particle is the diameter of a perfect mathematical sphere having the same volume as the particle.

[0088] In some embodiments, a plurality of identification elements may be chosen to identify droplets such that there are at least 3 distinguishable identification elements, at least 4 distinguishable identification elements, at least 6 distinguishable identification elements, at least 8 distinguishable identification elements, at least 9 distinguishable identification elements, at least about 10 distinguishable identification elements, at least about 20 distinguishable identification elements, at least about 30 distinguishable identification elements, at least about 40 distinguishable identification elements, at least about 50 distinguishable identification elements, at least about 60 distinguishable identification elements, at least about 70 distinguishable identification elements, at least about 80 distinguishable identification elements, at least about 90 distinguishable identification elements, at least about 100 distinguishable identification elements, etc. One non-limiting example of a plurality of distinguishable identification elements are the Luminex FlexMAP Microspheres beads commercially available from Luminex Corp. Beads or particles such as these may be distinguished, according to one embodiment, by the use of two or more dyes or other compounds that can be independently varied within each bead or particle. Therefore, a plurality of distinguishable beads may be used as a plurality of identification elements, according to certain embodiments. As another, specific non-limiting example, particles comprising polystyrene and one or more dyes may be used as identification elements. The dyes employed within the particles may include, for instance, squaric acid-based molecules or other fluorescent molecules that exhibit fluorescence, e.g., extending into near infrared and/or infrared region. In some cases, two or more dyes with concentrations that can be independently controlled can be used within each particle.

[0089] The sequence of a target nucleic acid may be determined by determining the association (or non-association) of the target nucleic acid to one of a plurality of distinguishable nucleic acid probes. The target nucleic acid may be associated with the nucleic acid probe when they form a relatively stable duplex by hydrogen bonding under experimental conditions. Relatively stable hydrogen bonding may be formed due to Watson-Crick complementarity (e.g., A matches T, but not G or C; G matches C, but not A or T) and/or other effects such as GC wobble, or other associations caused by locked nucleic acids or universal bases, as discussed herein. Non-limiting examples of suitable methods for determining the sequence of a target nucleic acid include sequencing by hybridization techniques that are known to those of ordinary skill in the art.

[0090] Sequencing by hybridization (SBH) is a method for examining the nucleic acid residue sequence in a target nucleic acid that has been previously described, for instance, in U.S. Pat. No. 5,202,231. In general, SBH uses a set of

nucleic acid probes of defined sequence to probe for complementary sequences on a longer target strand of a target nucleic acid. The defined sequences which hybridize to the target can then be aligned using computer algorithms to construct the sequence of the target nucleic acid.

[0091] Thus, in one embodiment of the present invention, a target nucleic acid may associate with a certain combination of nucleic acid probes, leading to a characteristic “hybridization” pattern. Each positive association (or hybridization) event in a given sample provides a discrete piece of information about the target nucleic acid. In some cases the target nucleic acid may be sampled without determination of exactly where any particular nucleic acid probe associates with the target nucleic acid. Algorithms and software have been developed for target nucleic acid reconstruction, based on the hybridization pattern, and are known to those skilled in the art. In other cases, however, analysis of a hybridization pattern, such as those described herein, may provide a “fingerprint” identification of the target nucleic acid sequence, without specifically determining the target nucleic acid sequence itself. The pattern of hybridization may also be manually or computer analyzed.

[0092] Another aspect of the present invention is generally directed to systems and techniques for creating a suspension of rigidified or fluidized droplets, where the droplets contain distinguishable species and/or identification elements. In some embodiments, a plurality of distinguishable identification elements may be used to identify a plurality of fluidic droplets, and in some cases, the distinguishable identification elements are used to determine a nucleic acid sequence (e.g., of a nucleic acid probe) present within each droplet. For instance, in one embodiment, at least about 64, at least about 256, at least about 1024, at least about 4096, or at least about 16,384 or more fluidic droplets may be prepared, each containing a nucleic acid probe (including multiple copies of the nucleic acid probe) and one or more identification elements that, in combination, identifies that nucleic acid probe and do not identify different nucleic acid probes. The present invention provides, in one set of embodiments, systems, and methods for preparing such collections of fluidized or rigidified droplets.

[0093] In one embodiment, a plurality of distinguishable identification elements are used to identify a plurality of fluidic droplets or nucleic acid probes or other suitable samples. For instance, if fluorescent particles are used, a set of distinguishable particles is first determined, e.g., having at least 5 distinguishable particles, at least about 10 distinguishable particles, at least about 20 distinguishable particles, at least about 30 distinguishable particles, at least about 40 distinguishable particles, at least about 50 distinguishable particles, at least about 75 distinguishable particles, or at least about 100 or more distinguishable particles. A non-limiting example of such a set is available from Luminex. The distinguishable identification elements may be divided into a plurality of groups (e.g., 2, 3, 4, 5, 6, 7, or more), where each group contains at least two members of the set of distinguishable identification elements.

[0094] A sample may then be associated with one member chosen from each of the groups of distinguishable identification elements. For instance, a first sample may be identified by the combination of a first element chosen from a first group, a first element chosen from a second group, and a first element chosen from a third group, as each of these elements is distinguishable from each other; a second sample may be

identified by the combination of a first element chosen from the first group, a first element chosen from the second group, but a second element chosen from the third group. The number of unique combinations, in this example, is simply the product of the number of members of each of the groups; a large number of distinguishable sets of identification elements can thus be prepared. Thus, for instance, by defining at least six identification elements, where the identification elements are arranged into at least three groups with each group having at least two identification elements, at least eight different samples can be determined by associating each of the at least eight samples with at least three of the identification elements, where each identification element associated with each sample is chosen such that there is one identification element from each of the at least three groups. Even larger numbers may be obtained by increasing the numbers of members in each group and/or the numbers of groups present. In addition, the number of members of each group may be the same, or different in some cases.

[0095] It should be noted that in other embodiments, other coding methods are also possible. For instance, the distinguishable elements may be used to represent binary digits, such that the nucleic acid probes or other samples are arbitrarily numbered and are identified by adding the binary digits corresponding to the distinguishable identification elements that are present.

[0096] Accordingly, in some embodiments, a species-containing droplet can be identified by introducing to the species-containing droplet, one or more identification elements that have been arranged in such a manner. Relatively large numbers of fluidic droplets can each be identified. For instance, a collection of tens, hundreds, or thousands of fluidic droplets, containing differing nucleic acid probes, may be identified by adding, to each of the droplets, three or four identification elements that have been determined in such a manner.

[0097] The composition of a plurality of droplets (e.g., fluidized, rigidified, and/or species-containing) will now be discussed. In some embodiments, droplets of the present invention comprise a precursor material, where the precursor material is capable of undergoing a phase change, e.g., to form a rigidified droplet or a fluidized droplet. Therefore, the droplet may be rigidified or fluidized by causing the precursor material to rigidify or fluidize. For instance, a droplet may contain a gel precursor and/or a polymer precursor that can be rigidified to form a rigidified droplet comprising a gel and/or a polymer. The rigidified droplet, in some cases, may also contain a fluid within the gel or polymer.

[0098] The rigidified droplet may be substantially porous or substantially non-porous. In some aspects, the rigidified droplet will be substantially porous such that at least one species may be contained internally within the rigidified droplet. As used herein, "contained internally" or "added internally" means that the species is substantially surrounded by the droplet. In other embodiments, however, a species may be contained within a non-porous droplet, or the species may be contained on the surface of the droplet (e.g., at an interface between the droplet and the fluid surrounding the droplet).

[0099] A droplet may be caused to undergo a phase change using any suitable technique. For example, a rigidified droplet may form a fluidized droplet by exposing the rigidified droplet to an environmental change. A droplet may be fluidized or rigidified by a change in the environment around the droplet, for example, a change in temperature, a change in the pH level, change in ionic strength, exposure to a electromagnetic

radiation (e.g., ultraviolet light), addition of a chemical (e.g., chemical that cleaves a crosslinker in a polymer), and the like. Some examples are given below.

[0100] As a specific example, in some cases, a droplet may be caused to undergo a phase change by raising or lowering the temperature of the droplet from a first temperature to a second temperature. For example, a first temperature may be raised or lowered to a second temperature by at least about 5° C., at least about 10° C., at least about 15° C., at least about 20° C., at least about 22° C., at least about 25° C., at least about 30° C., at least about 35° C., at least about 40° C., at least about 50° C., at least about 60° C., at least about 70° C., at least about 80° C., at least about 90° C., at least about 100° C., or to any other suitable temperature that may cause the droplet to undergo a phase change. As an specific example, a fluidic droplet comprising agarose may be rigidified by cooling the droplet to a temperature below the gelling temperature of agarose, or a rigidified droplet comprising agarose may be fluidized by warming. In some cases, the temperature change is chosen in part such that a species (e.g., a cell) contained within the droplet remains unchanged. Non-limiting examples of gels that may form upon a change in temperature include agarose, a PEG-PLGA-PEG triblock copolymer, Matrigel, or the like.

[0101] As another example, a droplet may be caused to undergo a phase change by raising or lowering the pH of the droplet from a first pH to a second pH. For example, a first pH may be raised or lowered to a second pH by at least about 0.5 pH units, at least about 1 pH unit, at least about 2 pH units, at least about 3 pH units, at least about 4 pH units, at least about 5 pH units, at least about 6 pH units, at least about 8 pH units, at least about 10 pH units, at least about 14 pH units, or to any other suitable pH that may cause the droplet to undergo a phase change. In some cases, the pH of the droplet may be changed from acidic to basic, basic to acidic, less acidic to more acidic, more acidic to less acidic, more basic to less basic, less basic to more basic, and the like. Non-limiting examples of gels that may undergo a phase change upon a change in pH include cellulose acetate phthalate latex and cross-linked poly acrylic or other carbomer derivatives (e.g., Polycarbophil® and Carbopol®).

[0102] As yet another example, the droplet may be caused to undergo a phase change by reaction with a chemical reagent, for example, a crosslinking reagent. For example, a polymer contained within a liquid can be crosslinked, thereby turning the liquid into a solid or a gel state by crosslinking the chains of the polymer together. In some instances, a crosslinking reaction may be initiated by heat, pressure, or electromagnetic radiation. In certain cases, a crosslinking agent will be used to rigidify a droplet. Addition of a cleaving reagent may cause the rigidified droplet to be fluidized (e.g., the cleaving agent will cause the crosslinks that formed during crosslinking to be cleaved). Examples of rigidified droplets that may be prepared using crosslinking reagents are discussed more herein.

[0103] In some embodiments, a rigidified droplet may be a gel droplet (e.g., a droplet comprising or consisting essentially of a gel). As used herein, the term "gel" is given its ordinary meaning in the art and refers to a material comprising a polymer network that is able to trap and contain fluids. For example, a rigidified droplet may contain fluid from the fluidic droplet prior to rigidification of the fluidic droplet. The gel may comprise polymer chains that are crosslinked. The degree of crosslinking may be varied, in some cases, to tailor

the extent to which the gel absorbs or retains fluids. Those of ordinary skill in the art will be able to select appropriate materials suitable for use as gels. In some cases, a gel may be formed from a gel precursor. For instance, the gel precursor may comprise a material that forms a gel upon reaction with another material (e.g., a photoinitiator or crosslinker). An example of a gel precursor includes polyacrylamide. In another embodiment, the gel precursor comprises a material that forms a gel upon application of electromagnetic radiation to the material, such as chitosan or poly(ethylene)glycol.

[0104] In some cases, a gel may be altered to form a fluidized state, e.g., a fluidic droplet. For instance, a polymer droplet may be fluidized by cleaving the crosslinks formed in the gel. Different types of gels and gel precursors that can be used in accordance with the present invention are described in more detail below.

[0105] In some embodiment, the gel is a natural gel; that is, a biologically-derived gel. A natural gel may include, for example, agarose (e.g., low melting point agarose), collagen, fibrin, laminin, Matrigel, alginate, and combinations thereof. In one particular embodiment, agarose is used. Droplets comprising natural gels and gel precursors, in some instances, may be rigidified or fluidized by a change in the temperature or pH of the droplet, etc.

[0106] Non-limiting examples of materials capable of forming gels from a liquid precursor include, but are not limited to, silicon-containing polymers, polyacrylamides (e.g., poly(N-isopropylacrylamide)), crosslinked polymers (e.g., polyethylene oxide, polyAMPS and polyvinylpyrrolidone), polyvinyl alcohol, acrylate polymers (e.g., sodium polyacrylate), and copolymers with an abundance of hydrophilic groups. Those of ordinary skill in the art can choose appropriate polymers that can be crosslinked, as well as suitable methods of crosslinking, based upon general knowledge of the art in combination with the description herein.

[0107] In some embodiments, a gel droplet may comprise a sol-gel. The term “sol-gel” as used herein means a gel derived from a sol, either by polymerizing the sol into an interconnected solid matrix, or by destabilizing the individual particles of a colloidal sol by means of an external agent. In general, the sol-gel process involves the change of a colloidal suspension system into a gel phase exhibiting a significantly higher viscosity. In some cases, the first liquid may comprise a sol-gel precursor comprising a mixture of solid particles (e.g., inorganic salts) suspended in a liquid, where a series of reactions including hydrolysis and polymerization reactions may be performed to form a rigidified droplet (e.g., a colloidal suspension). A non-limiting example of a sol-gel is silica xerogel. In some cases, the gel may be an organogel, where the polymer may be swollen by addition of an organic solvent.

[0108] A variety of definitions are now provided which will aid in understanding various aspects of the invention. Following, and interspersed with these definitions, is further disclosure that will more fully describe the invention.

[0109] A “droplet,” as used herein, is an isolated portion of a first fluid that is completely surrounded by a second fluid. It is to be noted that a droplet is not necessarily spherical, but may assume other shapes as well, for example, depending on the external environment. In one embodiment, the droplet has a minimum cross-sectional dimension that is substantially equal to the largest dimension of the channel perpendicular to fluid flow in which the droplet is located. The diameter of a droplet, in a non-spherical droplet, is the diameter of a perfect

mathematical sphere having the same volume as the non-spherical droplet. The fluidic droplets may be created using any suitable technique.

[0110] In some embodiments, a plurality of droplets may be prepared using microfluidic techniques, such as those disclosed in U.S. patent application Ser. No. 11/024,228, filed Dec. 28, 2004, entitled “Method and Apparatus for Fluid Dispersion,” by Stone, et al., published as U.S. Patent Application Publication No. 2005/0172476 on Aug. 11, 2005; U.S. patent application Ser. No. 11/246,911, filed Oct. 7, 2005, entitled “Formation and Control of Fluidic Species,” by Link, et al., published as U.S. Patent Application Publication No. 2006/0163385 on Jul. 27, 2006; or U.S. patent application Ser. No. 11/360,845, filed Feb. 23, 2006, entitled “Electronic Control of Fluidic Species,” by Link, et al., published as U.S. Patent Application Publication No. 2007/0003442 on Jan. 4, 2007, each incorporated herein by reference.

[0111] As used herein, a “fluid” is given its ordinary meaning, i.e., a liquid or a gas. A fluid cannot maintain a defined shape and will flow during an observable time frame to fill the container in which it is put. Thus, the fluid may have any suitable viscosity that permits flow. If two or more fluids are present, each fluid may be independently selected among essentially any fluids (liquids, gases, and the like) by those of ordinary skill in the art, by considering the relationship between the fluids. The fluids may each be substantially miscible or substantially immiscible. In some cases, two fluids can be selected to be substantially immiscible within the time frame of formation of a stream of fluids, or within the time frame of reaction or interaction. In instances where the portions remain liquid for a significant period of time then the fluids should be substantially immiscible. In instances where, after contact and/or formation, the dispersed portions are rigidified, the fluids may need not be substantially immiscible. Those of ordinary skill in the art can select suitable substantially miscible or substantially immiscible fluids, using contact angle measurements or the like, to carry out the techniques of the invention.

[0112] As used herein, a first entity is “surrounded” by a second entity if a closed loop can be drawn around the first entity through only the second entity. A first entity is “completely surrounded” if closed loops going through only the second entity can be drawn around the first entity regardless of direction. A first entity is “substantially surrounded” if the loops going through only the second entity can be drawn around the first entity depending on the direction (e.g., in some cases, a loop around the first entity will comprise mostly of the second entity by may also comprise a third entity, or a fourth entity, etc.) In some aspect of the invention, the entities can both be fluids. For example, a hydrophilic liquid may be suspended in a hydrophobic liquid, a hydrophobic liquid may be suspended in a hydrophilic liquid, a gas bubble may be suspended in a liquid, etc. Typically, a hydrophobic liquid and a hydrophilic liquid are substantially immiscible with respect to each other, where the hydrophilic liquid has a greater affinity to water than does the hydrophobic liquid. Examples of hydrophilic liquids include, but are not limited to, water and other aqueous solutions comprising water, such as cell or biological media, ethanol, salt solutions, etc. Examples of hydrophobic liquids include, but are not limited to, oils such as hydrocarbons, silicon oils, fluorocarbon oils, organic solvents etc.

[0113] A method of the present invention may provide a plurality of droplets. In some embodiments, the plurality of

droplets contain a first fluid and are substantially surrounded by a second fluid. In most, but not all embodiments, the first fluid and the second fluid are substantially immiscible. In some cases, however, the first and second fluids may be miscible. In some, but not all embodiments, the plurality of the droplets may be produced using microfluidic techniques, as discussed more herein. "Microfluidic," as used herein, refers to a device, apparatus or system including at least one fluid channel having a cross-sectional dimension of less than 1 mm, and a ratio of length to largest cross-sectional dimension of at least about 3:1.

[0114] As discussed herein, droplets produced using a microfluidic device may allow for the production of a plurality of droplets which have substantially the same composition. As used herein "substantially the same composition" refers to at least two droplets which comprise essentially the same material (e.g., fluid, polymer, gel, etc.). In some cases, two droplets which have substantially the same composition differ in their composition by no more than about 0.5%, no more than about 1%, no more than about 2%, no more than about 3%, no more than about 4%, no more than about 5%, no more than about 10%, no more than about 20%, and the like. Two droplets which have substantially the same composition may only differ in their composition because they contain distinguishable species. For example, the first droplet may comprise of a first fluid and contain internally at least one first species and the second droplets may comprise the same first fluid and contain internally at least one second species, where the first species and the second species are distinguishable with respect to each other. That is, the droplet comprise the same material (e.g., they are both formed of the same fluid, polymer, gel, etc.) but they each comprise at least one distinguishable species with respect to the other species.

[0115] The plurality of fluidic droplets (e.g., prepared using a microfluidic device) may be polydisperse (e.g., having a range of different sizes), or in some cases, the fluidic droplets may be monodisperse or substantially monodisperse, e.g., having a homogenous distribution of diameters, for instance, such that no more than about 10%, about 5%, about 3%, about 1%, about 0.03%, or about 0.01% of the droplets have an average diameter greater than about 10%, about 5%, about 3%, about 1%, about 0.03%, or about 0.01% of the average diameter. The "average diameter" of a population of droplets, as used herein, is the arithmetic average of the diameters of the droplets. Those of ordinary skill in the art will be able to determine the average diameter of a population of droplets, for example, using laser light scattering or other known techniques. As non-limiting examples, the average diameter of a droplet may be less than about 1 mm, less than about 500 micrometers, less than about 200 micrometers, less than about 100 micrometers, less than about 75 micrometers, less than about 50 micrometers, less than about 25 micrometers, less than about 10 micrometers, or less than about 5 micrometers. The average diameter of the droplet may also be at least about 1 micrometer, at least about 2 micrometers, at least about 3 micrometers, at least about 5 micrometers, at least about 10 micrometers, at least about 15 micrometers, or at least about 20 micrometers in certain cases.

[0116] In some, but not all embodiments, all components of the systems and methods described herein are microfluidic. "Microfluidic," as used herein, refers to a device, apparatus or system including at least one fluid channel having a cross-sectional dimension of less than 1 mm, and a ratio of length to largest cross-sectional dimension perpendicular to the chan-

nel of at least about 3:1. A "microfluidic channel," as used herein, is a channel meeting these criteria. As mentioned above, a plurality of droplets of the present invention may be produced using microfluidic techniques. A benefit of using a plurality of droplets prepared using microfluidic techniques to prepare a plurality of fluidized or rigidified droplets comprising species is that the droplets, in most cases, will be monodisperse. Therefore, the properties of the droplets (e.g., size, shape, composition) of a first droplet in the suspension comprising a first type of species should be substantially similar to a second droplet in the suspension comprising a second type of species (with the exception of the distinguishing species). The monodisperse property of this technique may be difficult to achieve using other techniques, for example, producing a first and a second droplet comprising a first and a second species, respectively, directly from a microfluidic instrument (as opposed to the addition of the species after formation of a plurality of substantially similar droplets).

[0117] Microfluidic systems may be provided that are able to cause two or more droplets to fuse or coalesce into one droplet, for example, in cases where the two or more droplets ordinarily are unable to fuse or coalesce, for example due to composition, surface tension, droplet size, etc. as known to those of ordinary skill in the art. Examples of embodiments in which two or more droplets are fused have been described above. The fluidic droplets may be fused together using any suitable technique, for example, as discussed in U.S. patent application Ser. No. 11/246,911, filed Oct. 7, 2005, entitled "Formation and Control of Fluidic Species," by Link, et al., published as U.S. Patent Application Publication No. 2006/0163385 on Jul. 27, 2006; or U.S. patent application Ser. No. 11/360,845, filed Feb. 23, 2006, entitled "Electronic Control of Fluidic Species," by Link, et al., published as U.S. Patent Application Publication No. 2007/0003442 on Jan. 4, 2007, each incorporated herein by reference. As an example, in microfluidic systems, the surface tension of the droplets, relative to the size of the droplets may prevent fusion or coalescence of the droplets from occurring. In one embodiment, two droplets may be given opposite electrical charges (i.e., positive and negative charges, not necessarily of the same magnitude), which may increase the electrical interaction of the two droplets such that fusion or coalescence of the droplets can occur. Electrical charges (positive or negative) may be imparted onto droplets through the use of Taylor cones, or through any other suitable techniques. For instance, an electric field may be imposed on a reactor containing the droplets, the droplets may be passed through a capacitor, a chemical reaction may occur to cause the droplets to become charged, flowing the droplets over a region with opposite wetting properties, etc.

[0118] The "cross-sectional dimension" of the channel is measured perpendicular to the direction of fluid flow. Most fluid channels in components of the invention have maximum cross-sectional dimensions less than 2 mm, and in some cases, less than 1 mm. In one set of embodiments, all fluid channels containing embodiments of the invention are microfluidic or have a largest cross sectional dimension of no more than 2 mm or 1 mm. In another embodiment, the fluid channels may be formed in part by a single component (e.g., an etched substrate or molded unit). Of course, larger channels, tubes, chambers, reservoirs, etc. can be used to store fluids in bulk and to deliver fluids to components of the invention. In one set of embodiments, the maximum cross-

sectional dimension of the channel(s) containing embodiments of the invention are less than 500 microns, less than 200 microns, less than 100 microns, less than 50 microns, or less than 25 microns.

[0119] A “channel,” as used herein, means a feature on or in an article (substrate) that at least partially directs the flow of a fluid. The channel can have any cross-sectional shape (circular, oval, triangular, irregular, square, or rectangular, or the like) and can be covered or uncovered. In embodiments where it is completely covered, at least one portion of the channel can have a cross-section that is completely enclosed, or the entire channel may be completely enclosed along its entire length with the exception of its inlet(s) and outlet(s). A channel may also have an aspect ratio (length to average cross sectional dimension) of at least about 2:1, more typically at least about 3:1, at least about 5:1, or at least about 10:1 or more. An open channel generally will include characteristics that facilitate control over fluid transport, e.g., structural characteristics (an elongated indentation) and/or physical or chemical characteristics (hydrophobicity vs. hydrophilicity) or other characteristics that can exert a force (e.g., a containing force) on a fluid. The fluid within the channel may partially or completely fill the channel. In some cases where an open channel is used, the fluid may be held within the channel, for example, using surface tension (i.e., a concave or convex meniscus).

[0120] The channel may be of any size, for example, having a largest dimension perpendicular to fluid flow of less than about 5 mm or 2 mm, or less than about 1 mm, or less than about 500 microns, less than about 200 microns, less than about 100 microns, less than about 60 microns, less than about 50 microns, less than about 40 microns, less than about 30 microns, less than about 25 microns, less than about 10 microns, less than about 3 microns, less than about 1 micron, less than about 300 nm, less than about 100 nm, less than about 30 nm, or less than about 10 nm. In some cases the dimensions of the channel may be chosen such that fluid is able to freely flow through the article or substrate. The dimensions of the channel may also be chosen, for example, to allow a certain volumetric or linear flowrate of fluid in the channel. Of course, the number of channels and the shape of the channels can be varied by any method known to those of ordinary skill in the art. In some cases, more than one channel or capillary may be used. For example, two or more channels may be used, where they are positioned inside each other, positioned adjacent to each other, positioned to intersect with each other, etc.

[0121] Non-limiting examples of microfluidic systems that may be used with the present invention are disclosed in U.S. patent application Ser. No. 11/246,911, filed Oct. 7, 2005, entitled “Formation and Control of Fluidic Species,” published as U.S. Patent Application Publication No. 2006/0163385 on Jul. 27, 2006; U.S. patent application Ser. No. 11/024,228, filed Dec. 28, 2004, entitled “Method and Apparatus for Fluid Dispersion,” published as U.S. Patent Application Publication No. 2005/0172476 on Aug. 11, 2005; U.S. patent application Ser. No. 11/360,845, filed Feb. 23, 2006, entitled “Electronic Control of Fluidic Species,” published as U.S. Patent Application Publication No. 2007/000342 on Jan. 4, 2007; International Patent Application No. PCT/US2006/007772, filed Mar. 3, 2006, entitled “Method and Apparatus for Forming Multiple Emulsions,” published as WO 2006/096571 on Sep. 14, 2006; U.S. patent application Ser. No. 11/368,263, filed Mar. 3, 2006, entitled “Systems and Meth-

ods of Forming Particles,” published as U.S. Patent Application Publication No. 2007/0054119 on Mar. 8, 2007; U.S. Provisional Patent Application Ser. No. 60/920,574, filed Mar. 28, 2007, entitled “Multiple Emulsions and Techniques for Formation”; and International Patent Application No. PCT/US2006/001938, filed Jan. 20, 2006, entitled “Systems and Methods for Forming Fluidic Droplets Encapsulated in Particles Such as Colloidal Particles,” published as WO 2006/078841 on Jul. 27, 2006, each incorporated herein by reference.

[0122] The term “determining,” as used herein, generally refers to the analysis or measurement of a target analyte molecule, for example, quantitatively or qualitatively, or the detection of the presence or absence of a target analyte molecule. “Determining” may also refer to the analysis or measurement of an interaction between at least one species and a target analyte molecule, for example, quantitatively or qualitatively, or by detecting the presence or absence of the interaction. Example techniques include, but are not limited to, spectroscopy such as infrared, absorption, fluorescence, UV/visible, FTIR (“Fourier Transform Infrared Spectroscopy”), or Raman; gravimetric techniques; ellipsometry; piezoelectric measurements; immunoassays; electrochemical measurements; optical measurements such as optical density measurements; circular dichroism; light scattering measurements such as quasidelectric light scattering; polarimetry; refractometry; or turbidity measurements.

[0123] In one embodiment, a kit may be provided, containing one or more of the above compositions. A “kit,” as used herein, typically defines a package or an assembly including one or more of the compositions of the invention, and/or other compositions associated with the invention, for example, as previously described. Each of the compositions of the kit may be provided in liquid form (e.g., in solution), in solid form (e.g., a dried powder), etc. A kit of the invention may, in some cases, include instructions in any form that are provided in connection with the compositions of the invention in such a manner that one of ordinary skill in the art would recognize that the instructions are to be associated with the compositions of the invention. For instance, the instructions may include instructions for the use, modification, mixing, diluting, preserving, administering, assembly, storage, packaging, and/or preparation of the compositions and/or other compositions associated with the kit. The instructions may be provided in any form recognizable by one of ordinary skill in the art as a suitable vehicle for containing such instructions, for example, written or published, verbal, audible (e.g., telephonic), digital, optical, visual (e.g., videotape, DVD, etc.) or electronic communications (including Internet or web-based communications), provided in any manner.

[0124] Incorporated herein by reference is a U.S. Provisional Patent Application Ser. No. 61/098,674, filed Sep. 19, 2008, entitled “Creation of Libraries of Droplets and Related Species,” by Weitz, et al., U.S. Provisional Patent Application Ser. No. 61/008,862, filed Dec. 21, 2007, entitled “Systems and Methods for Nucleic Acid Sequencing,” by Weitz, et al., U.S. Provisional Patent Application Ser. No. 61/098,710, filed Sep. 19, 2008, entitled “Systems and Methods for Nucleic Acid Sequencing,” by Weitz, et al., and International Patent Application No. PCT/US2008/013912, filed Dec. 19, 2008, entitled “Systems and Methods for Nucleic Acid Sequencing,” by Weitz, et al.

[0125] The following examples are intended to illustrate certain embodiments of the present invention, but do not exemplify the full scope of the invention.

Example 1

[0126] The following example describes the formation of a plurality of rigidified droplets comprising a first group of rigidified droplets comprising a first species and a second group of rigidified droplets comprising a second species, wherein the first species and the second species are distinguishable from each other, according to one embodiment of the present invention.

[0127] A plurality of rigidified droplets were formed using microfluidic techniques as follows. A solution comprising water, 5% acrylamide, 0.25% bisacrylamide, 0.1% ammonium persulfate, and 1 uM of a first acrydite-labeled DNA oligonucleotide 20-mer was flowed through the center channel of a microfluidic device and focused by oil containing 0.1% TEMED in the side channels through a 10 micron nozzle to produce approximately 12 micron pre-gel droplets, as depicted in FIG. 9A. The droplets were allowed to rigidify for 30 minutes at 50° C. via polymerization reactions. FIG. 9B shows the plurality of rigidified droplets after being exposed to water.

[0128] The above steps (e.g., FIGS. 9A and 9B) were repeated for a second group of droplets comprising a second acrydite-labeled DNA oligonucleotide 20-mer that was distinguishable from the first DNA oligonucleotide 20-mer. A suspension of droplets was formed comprising some of the first group and the second group of rigidified droplets. The suspension of rigidified droplets was exposed to a plurality of a first type and a second type distinguishably labeled oligonucleotide specific to the first DNA oligonucleotide and the second DNA oligonucleotide, respectively. The distinguishably labeled oligonucleotides hybridized to the specified DNA in the rigidified droplets. FIG. 9C shows a fluorescence microscope image of the rigidified droplets following hybridization wherein one type of rigidified droplets is shown in grey and the other type is shown in white.

[0129] While several embodiments of the invention have been described and illustrated herein, those of ordinary skill in the art will readily envision a variety of other means and/or structures for performing the functions and/or obtaining the results and/or one or more of the advantages described herein, and each of such variations or modifications is deemed to be within the scope of the present invention. More generally, those skilled in the art will readily appreciate that all parameters, dimensions, materials, and configurations described herein are meant to be exemplary and that the actual parameters, dimensions, materials, and configurations will depend upon the specific application or applications for which the teachings of the present invention is/are used. Those skilled in

the art will recognize, or be able to ascertain using no more than routine experimentation, many equivalents to the specific embodiments of the invention described herein. It is, therefore, to be understood that the foregoing embodiments are presented by way of example only and that, within the scope of the appended claims and equivalents thereto, the invention may be practiced otherwise than as specifically described and/or claimed. The present invention is directed to each individual feature, system, material and/or method described herein. In addition, any combination of two or more such features, systems, articles, materials and/or methods, if such features, systems, articles, materials and/or methods are not mutually inconsistent, is included within the scope of the present invention.

[0130] All definitions as used herein are solely for the purposes of this disclosure. These definitions should not necessarily be imputed to other commonly-owned patents and/or patent applications, whether related or unrelated to this disclosure. The definitions, as used herein, should be understood to control over dictionary definitions, definitions in documents incorporated by reference, and/or ordinary meanings of the defined terms.

[0131] It should also be understood that, unless clearly indicated to the contrary, in any methods claimed herein that include more than one act, the order of the acts of the method is not necessarily limited to the order in which the acts of the method are recited.

[0132] In the claims, as well as in the specification above, all transitional phrases such as “comprising,” “including,” “carrying,” “having,” “involving,” “holding,” and the like are to be understood to be open-ended, i.e., to mean including but not limited to. Only the transitional phrases “consisting of” and “consisting essentially of” shall be closed or semi-closed transitional phrases, respectively, as set forth in the United States Patent Office Manual of Patent Examining Procedure, Section 2111.03.

What is claimed is:

1.-91. (canceled)

92. A composition, comprising:

a container comprising at least eight mutually distinguishable rigidified droplets, each having substantially the same composition but containing a distinguishable species with respect to the other rigidified droplets.

99. The composition of claim 92, wherein the composition comprises a gel.

105. The composition of claim 99, wherein the gel may be fluidized.

106. The composition of claim 92, wherein the composition comprises a polymer.

110. The composition of claim 106, wherein the polymer may be fluidized.

111.-155. (canceled)

* * * * *