



(19) **United States**

(12) **Patent Application Publication**
Swayze et al.

(10) **Pub. No.: US 2020/0375585 A1**
(43) **Pub. Date: Dec. 3, 2020**

- (54) **INTERCHANGEABLE TOOLS FOR SURGICAL INSTRUMENTS**
- (71) Applicant: **Ethicon LLC**, Guaynabo, PR (US)
- (72) Inventors: **Jeffrey S. Swayze**, West Chester, OH (US); **Thomas W. Huitema**, West Chester, OH (US); **Glen A. Armstrong**, Liberty Township, OH (US); **Shailendra K. Parihar**, Mason, OH (US); **Donna L. Korvick**, San Antonio, TX (US); **Richard W. Timm**, Cincinnati, OH (US); **Frederick E. Shelton, IV**, Hillsboro, OH (US); **Kevin R. Doll**, Mason, OH (US); **Bret W. Smith**, South Lebanon, OH (US); **William D. Kelly**, Los Altos, CA (US); **Ronald J. Kolata**, Raleigh, NC (US); **Joshua R. Uth**, Mason, OH (US); **Charles J. Scheib**, Loveland, OH (US); **Eugene L. Timperman**, Cincinnati, OH (US)

- A61B 17/29* (2006.01)
- A61B 17/295* (2006.01)
- A61B 17/3205* (2006.01)
- A61B 17/32* (2006.01)
- A61B 17/34* (2006.01)
- A61B 18/12* (2006.01)
- A61B 18/14* (2006.01)
- A61M 5/28* (2006.01)
- A61B 10/00* (2006.01)
- (52) **U.S. Cl.**
CPC ... *A61B 17/00234* (2013.01); *A61M 5/31581* (2013.01); *A61B 17/0682* (2013.01); *A61B 17/07207* (2013.01); *A61B 17/1285* (2013.01); *A61B 17/29* (2013.01); *A61B 17/295* (2013.01); *A61B 17/3205* (2013.01); *A61B 17/320016* (2013.01); *A61B 17/3401* (2013.01); *A61B 18/1206* (2013.01); *A61B 18/1445* (2013.01); *A61M 5/28* (2013.01); *A61B 10/00* (2013.01); *A61B 17/068* (2013.01)

- (21) Appl. No.: **16/916,375**
- (22) Filed: **Jun. 30, 2020**

Related U.S. Application Data

- (63) Continuation of application No. 15/804,160, filed on Nov. 6, 2017, now Pat. No. 10,743,851, which is a continuation of application No. 14/272,197, filed on May 7, 2014, now abandoned, which is a continuation of application No. 12/031,611, filed on Feb. 14, 2008, now Pat. No. 8,758,391.

Publication Classification

- (51) **Int. Cl.**
A61B 17/00 (2006.01)
A61B 17/068 (2006.01)
A61B 17/072 (2006.01)
A61B 17/128 (2006.01)

(57) **ABSTRACT**

A surgical tool system. Various embodiments of the surgical tool system may comprise surgical instrument that has a handle assembly that operably supports a drive system therein for generating drive motions upon actuation of a movable handle portion operably coupled to the handle assembly. An elongated body protrudes from the handle assembly and operably supports a control rod therein that interfaces with the drive system. The surgical tool system further includes at least two surgical tools selected from the group of surgical tools consisting of: manipulators, nippers, scissors, endocutters, tissue thickness measurement devices, staple appliers, clip appliers, syringes for applying glue, sealant, drugs or medicaments and cauterization devices wherein each of the surgical tool within the group of surgical tools at least has a housing that is removably couplable to the elongated body and a drive assembly that is removably couplable to the control rod for receiving the drive motions therefrom.

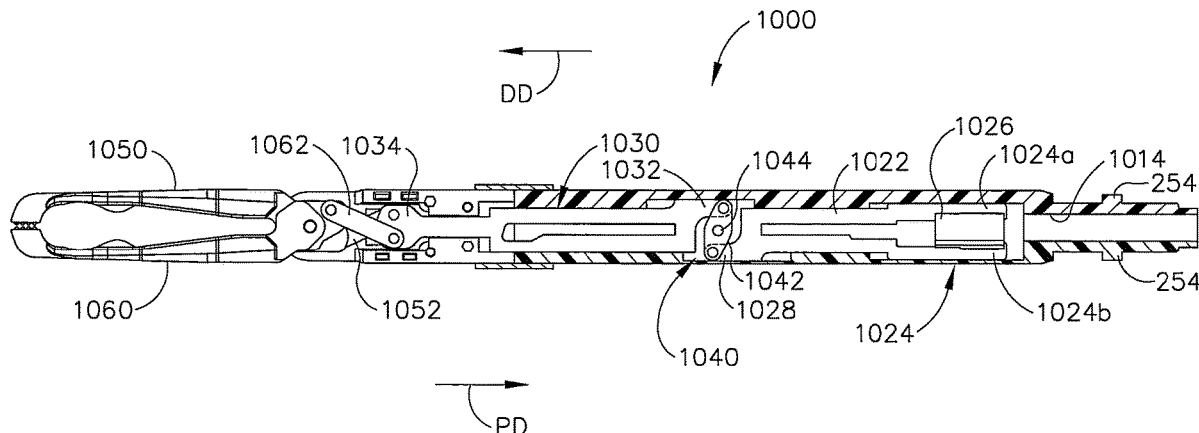

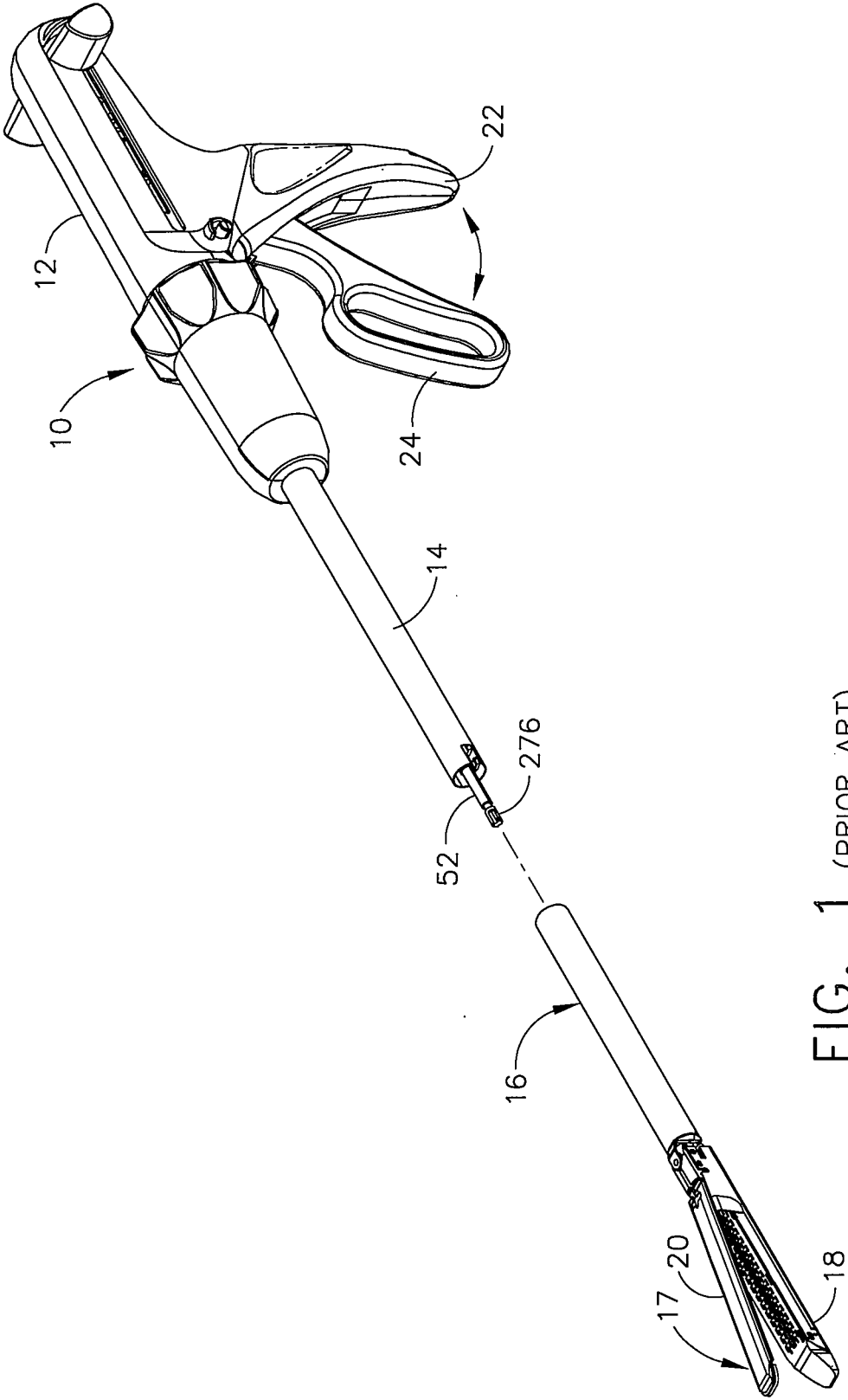

FIG. 1 (PRIOR ART)

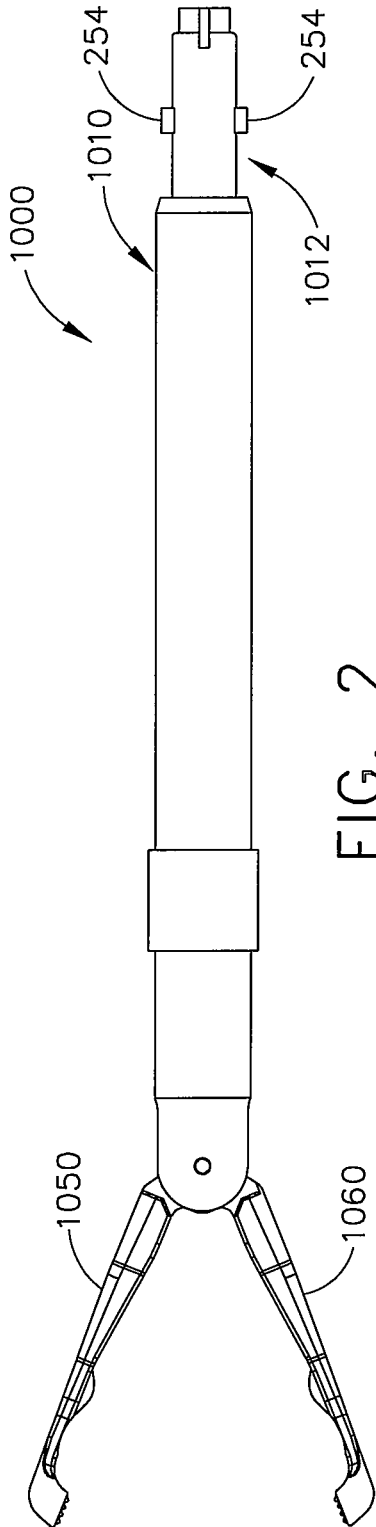

FIG. 2

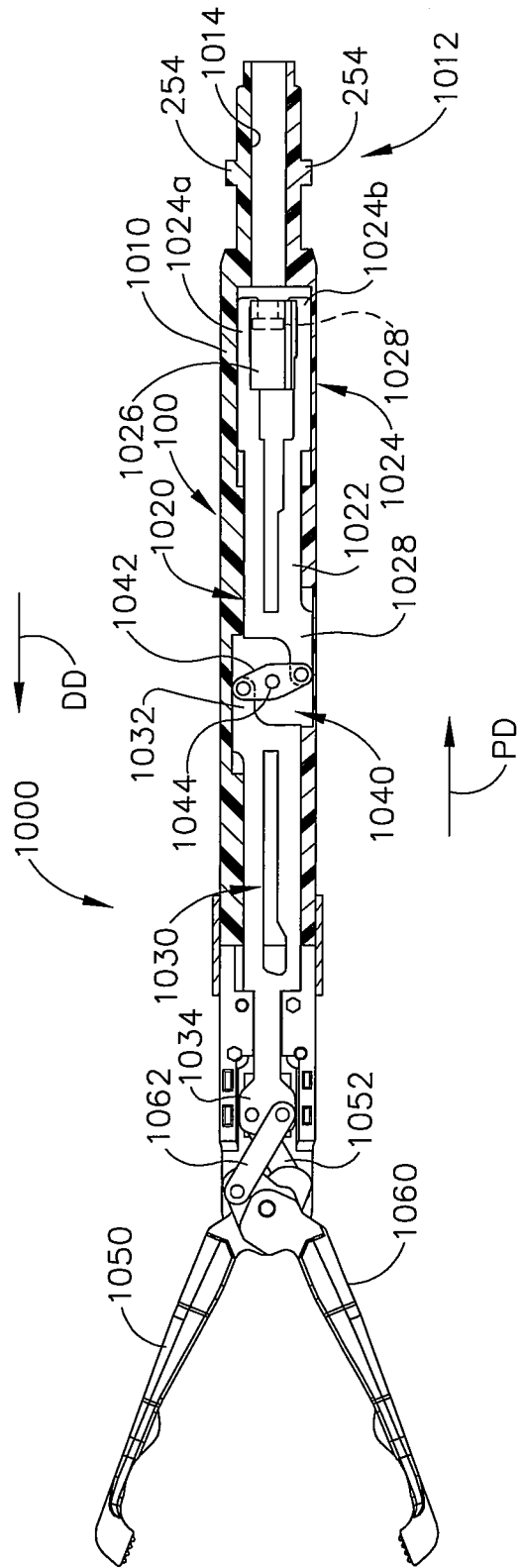

FIG. 3

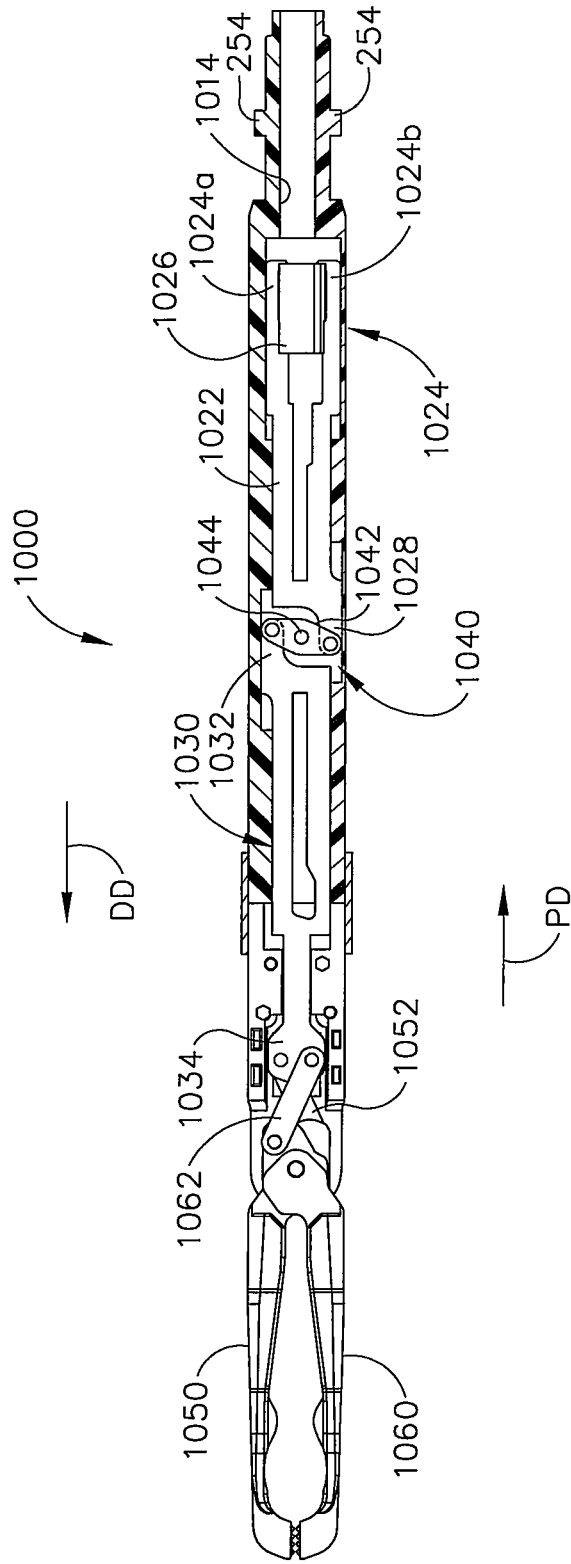

FIG. 4

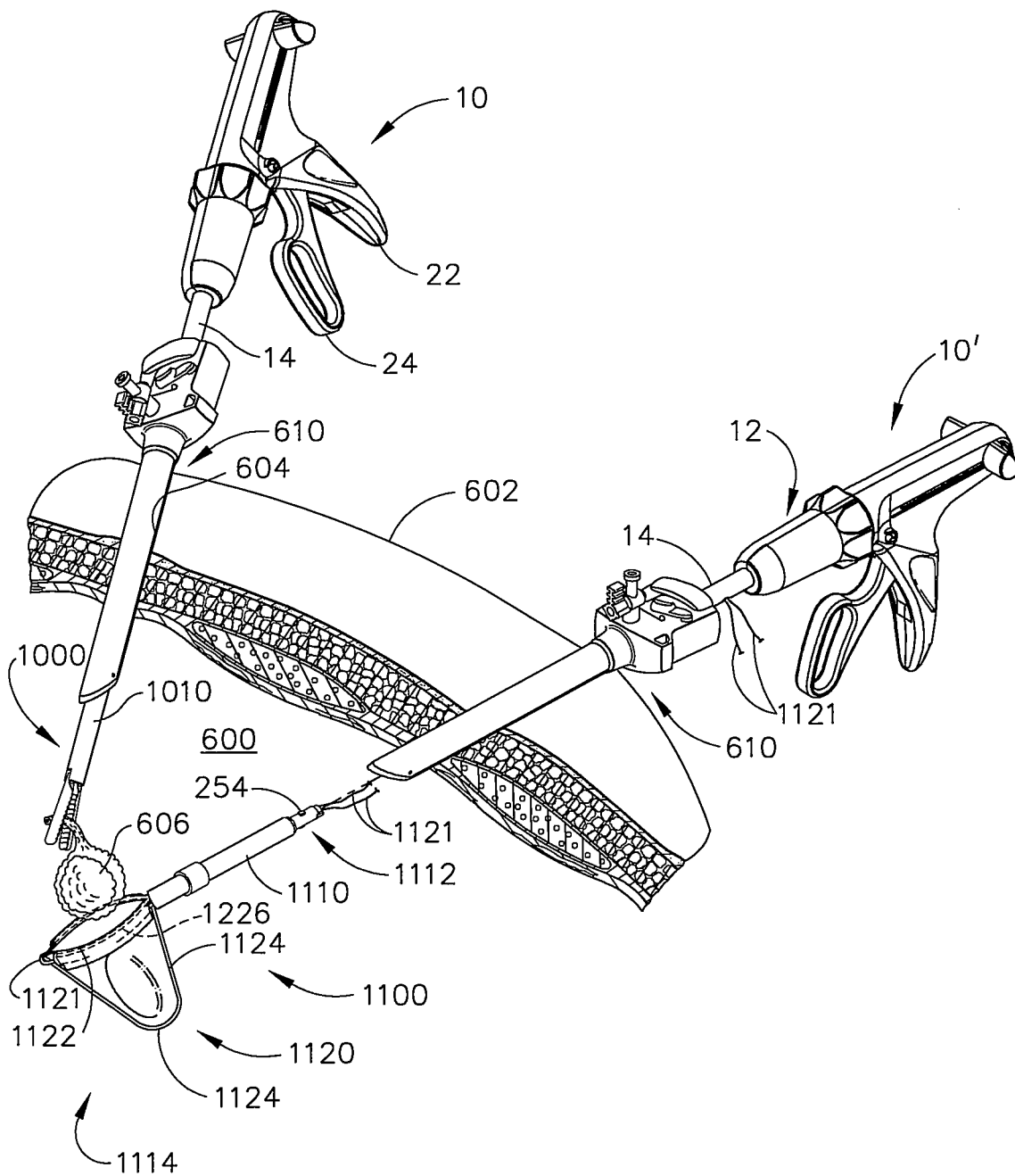

FIG. 5

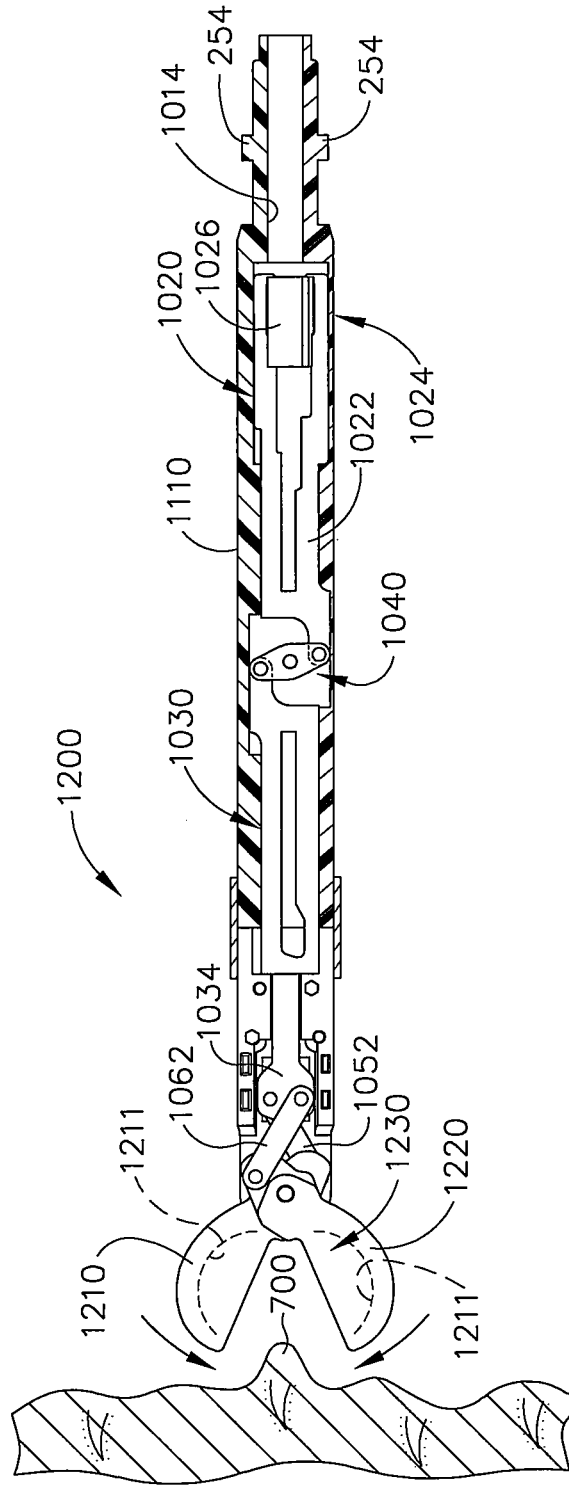

FIG. 6

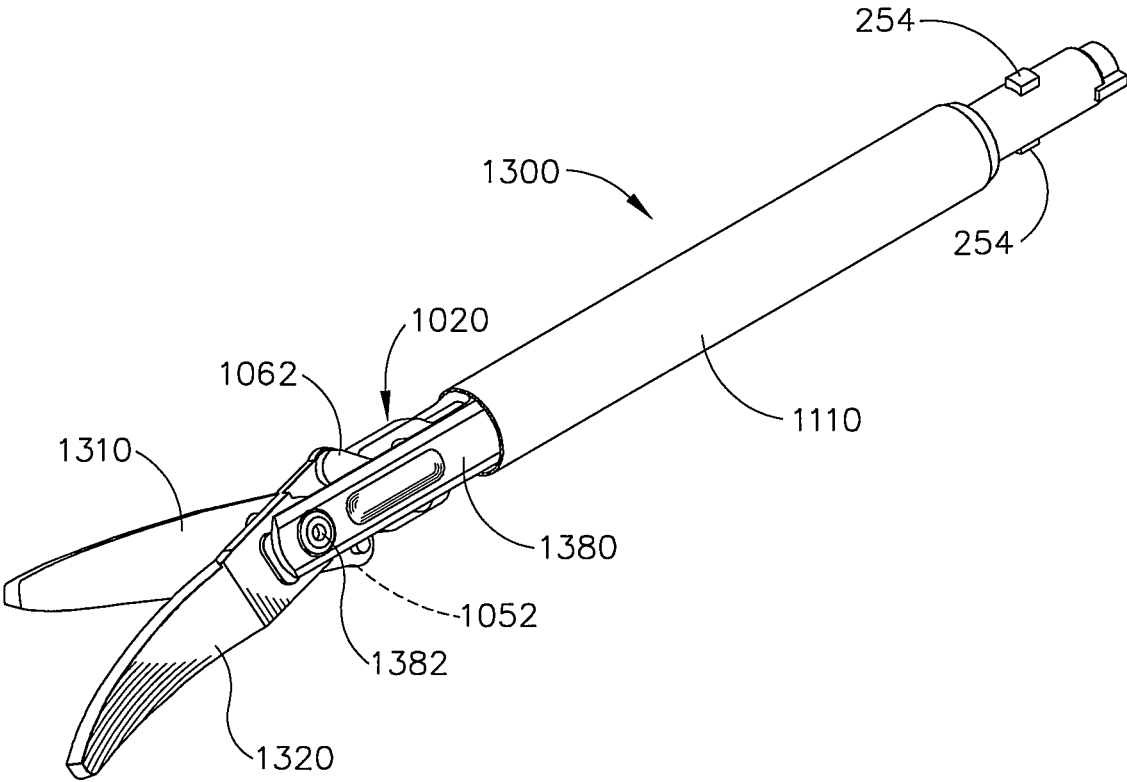

FIG. 7

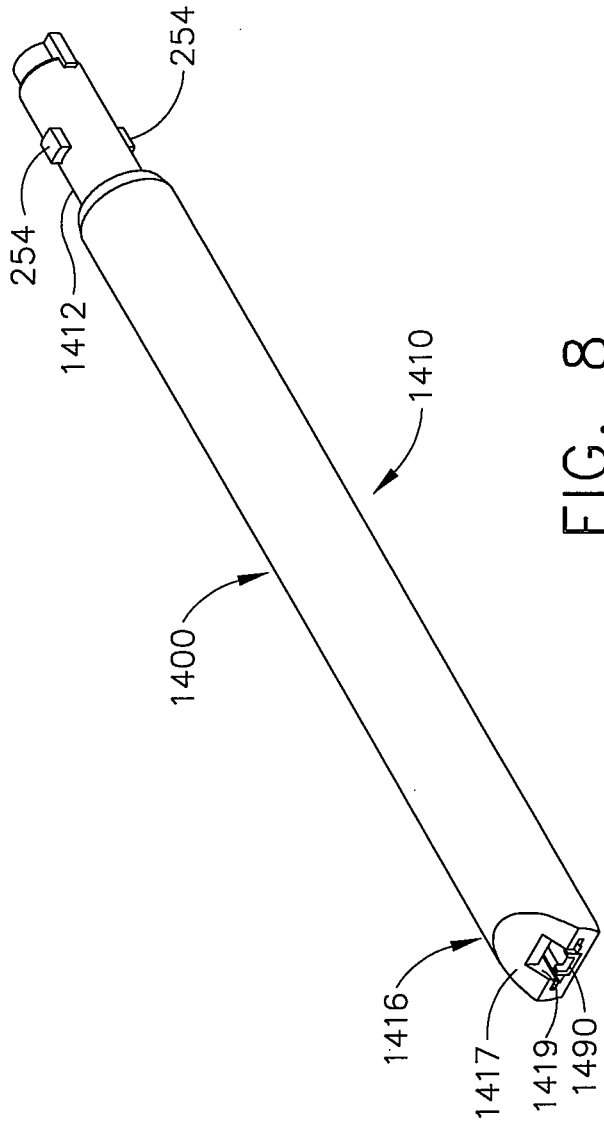

FIG. 8

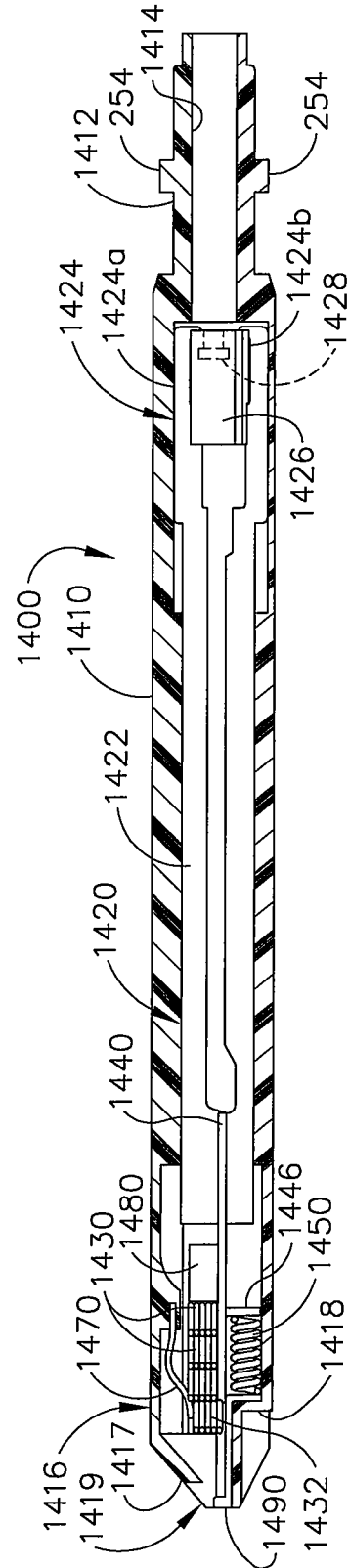

FIG. 9

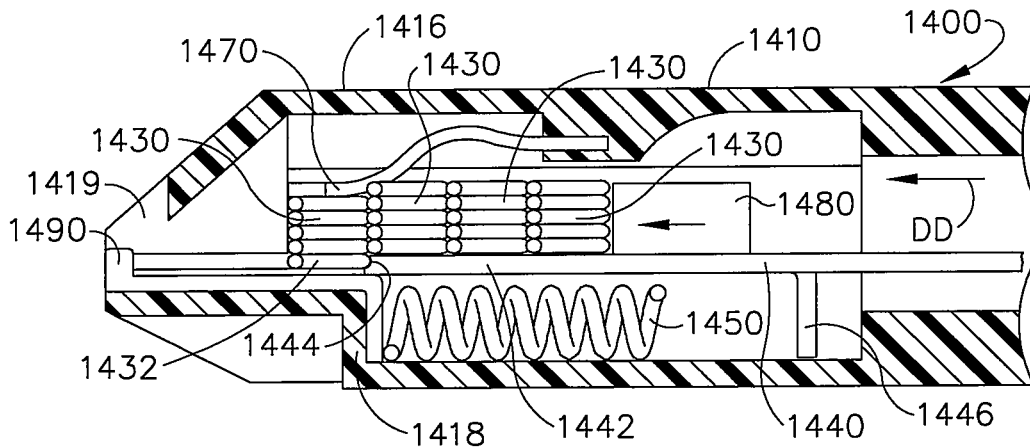

FIG. 10

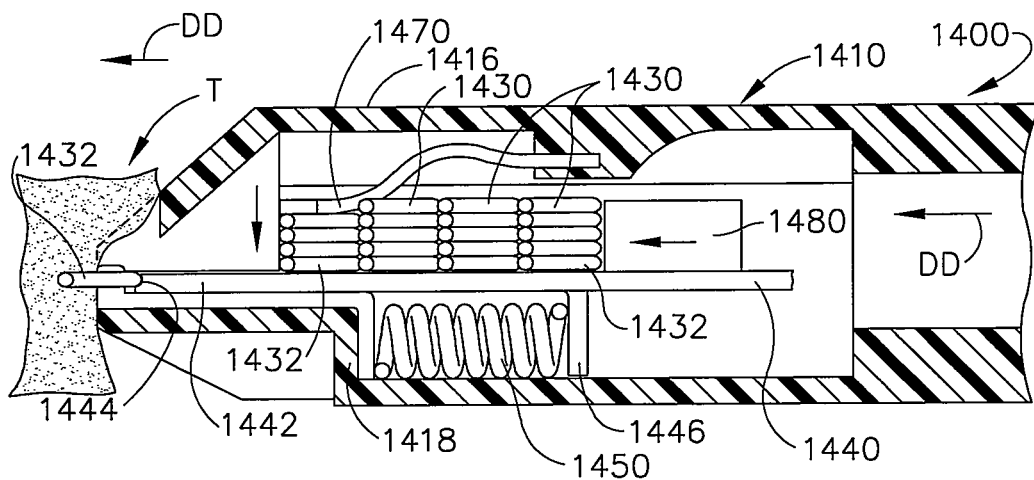

FIG. 11

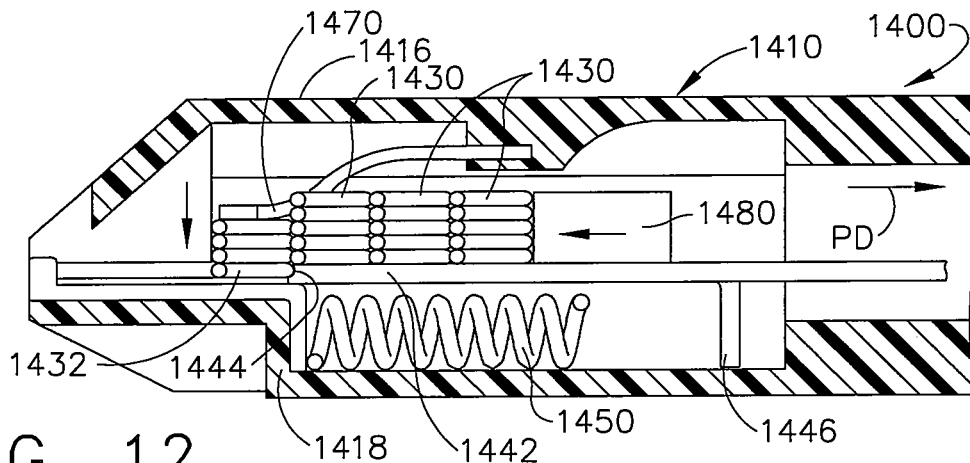

FIG. 12

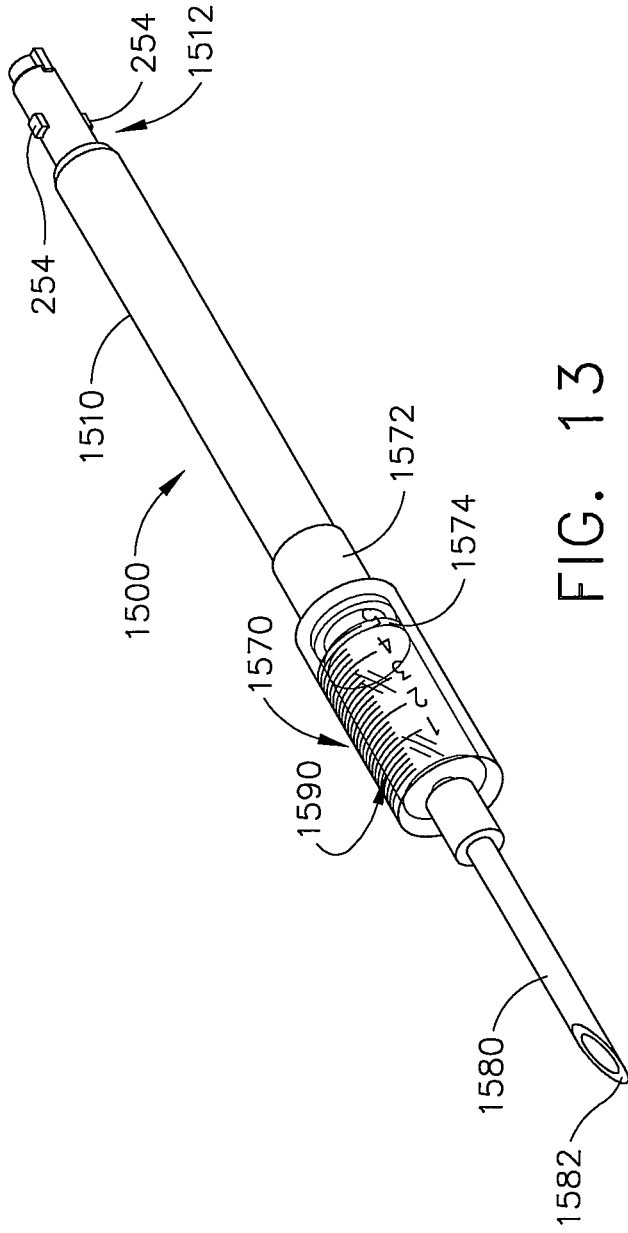

FIG. 13

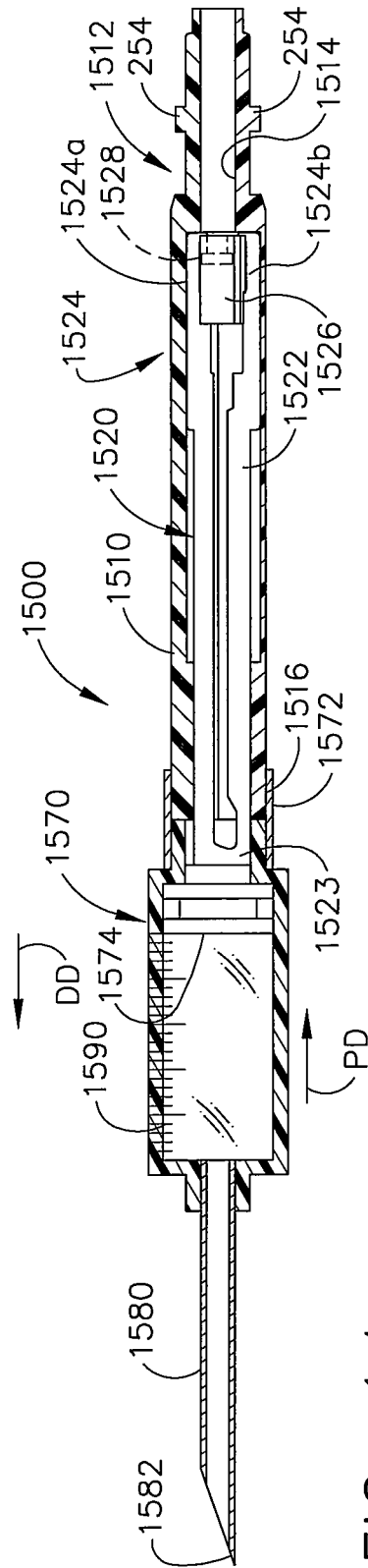

FIG. 14

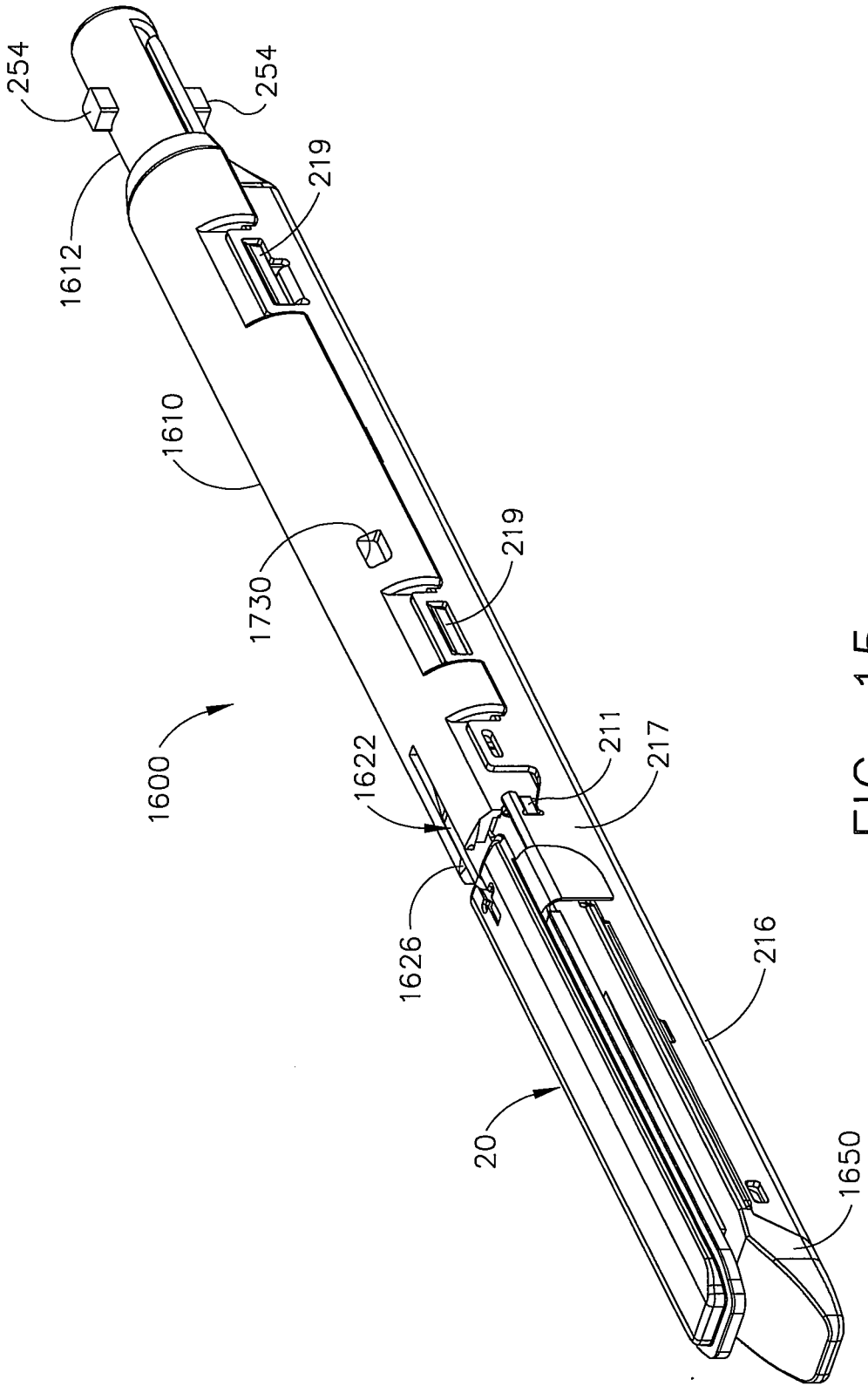

FIG. 15

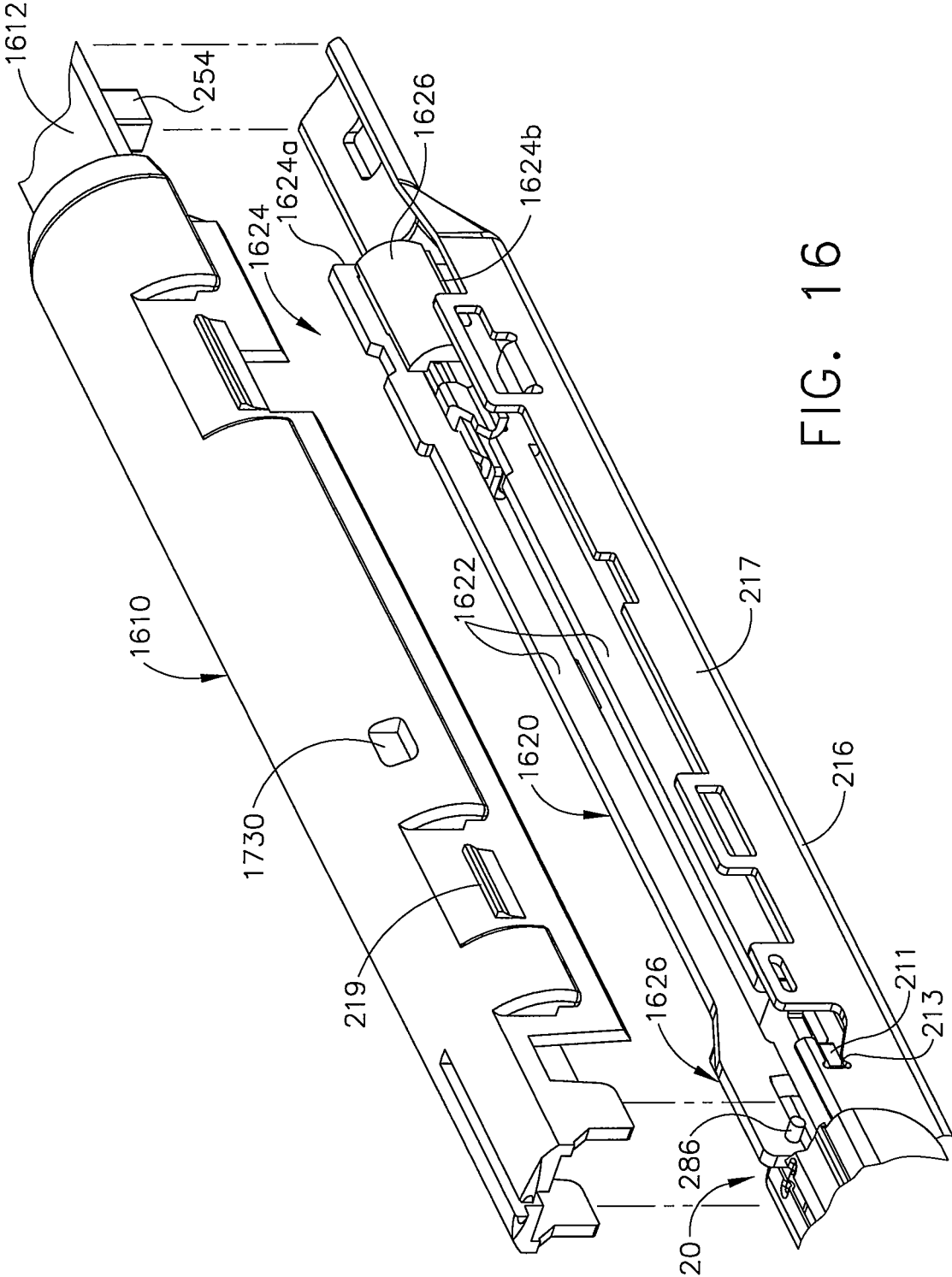

FIG. 16

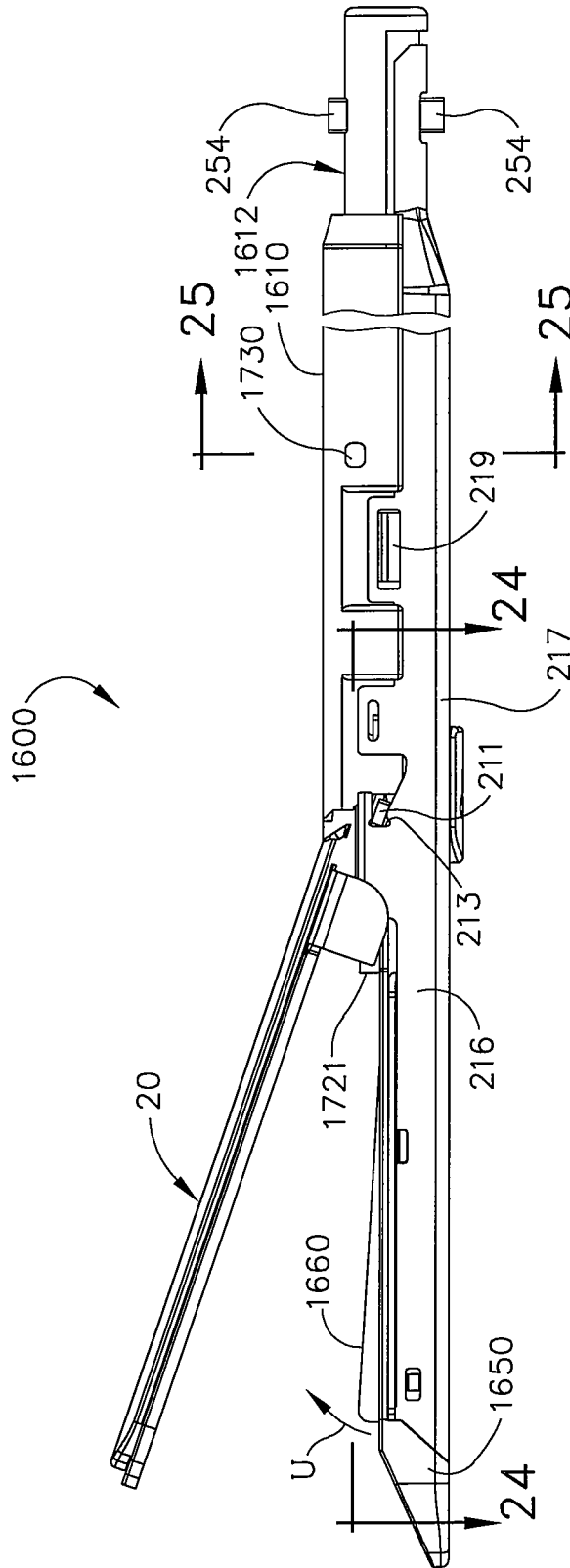

FIG. 17

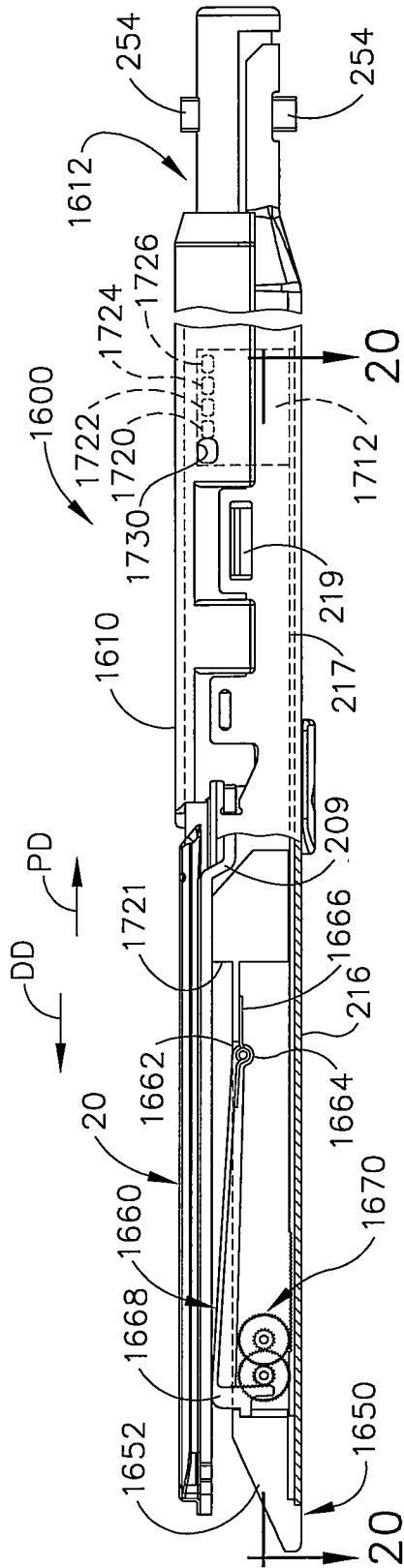

FIG. 18

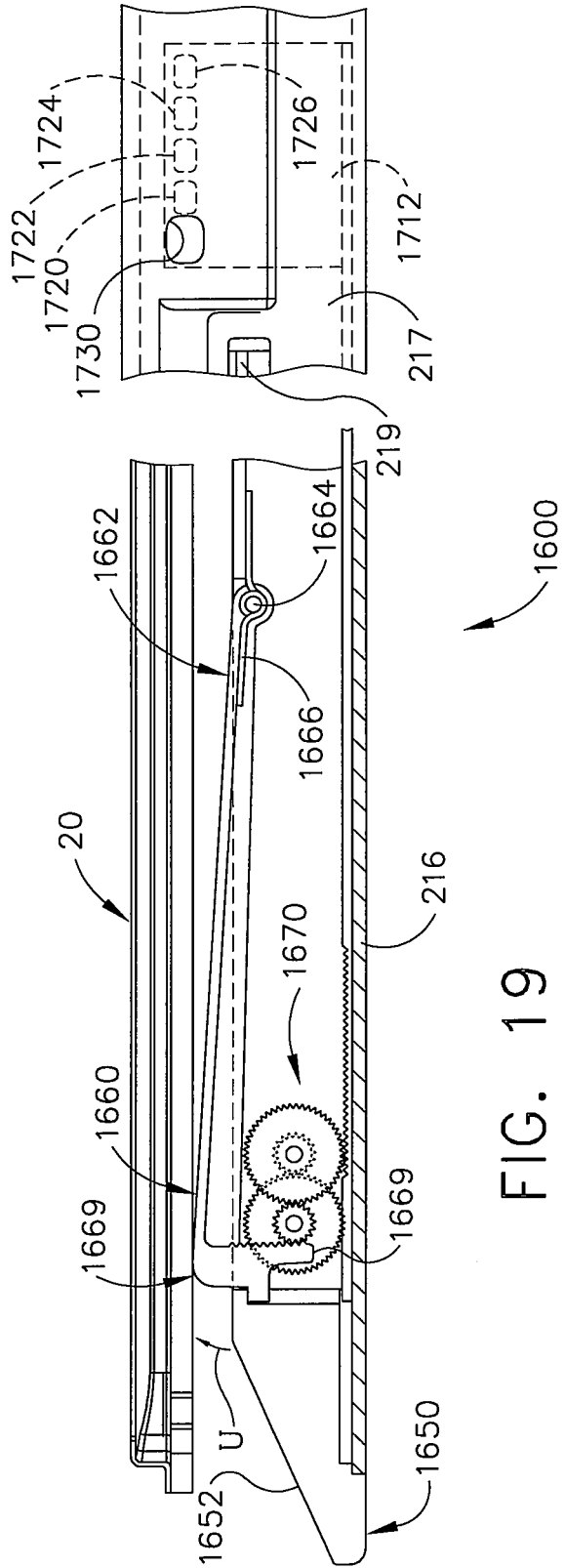

FIG. 19

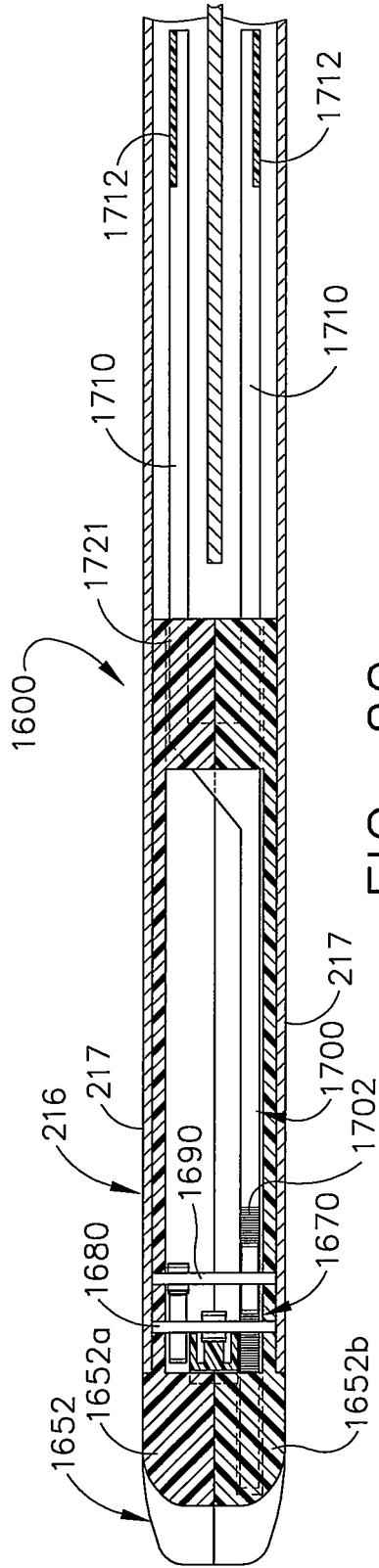

FIG. 20

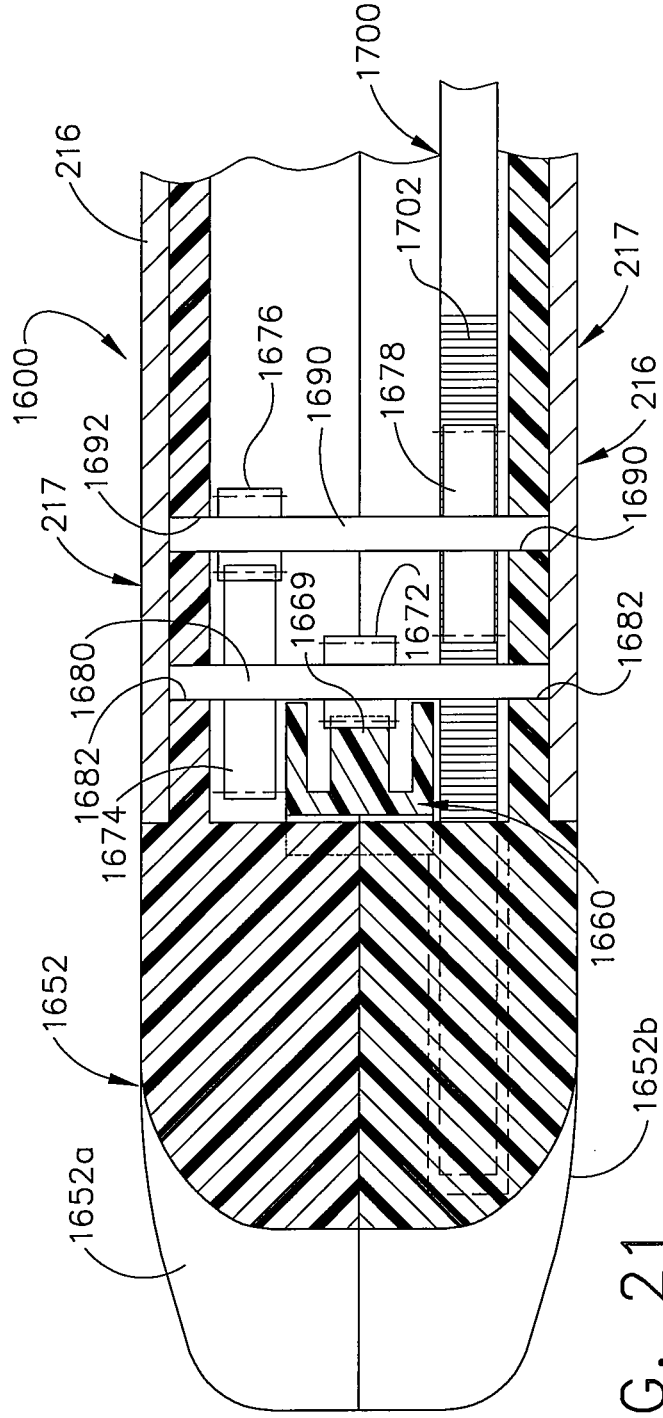

FIG. 21

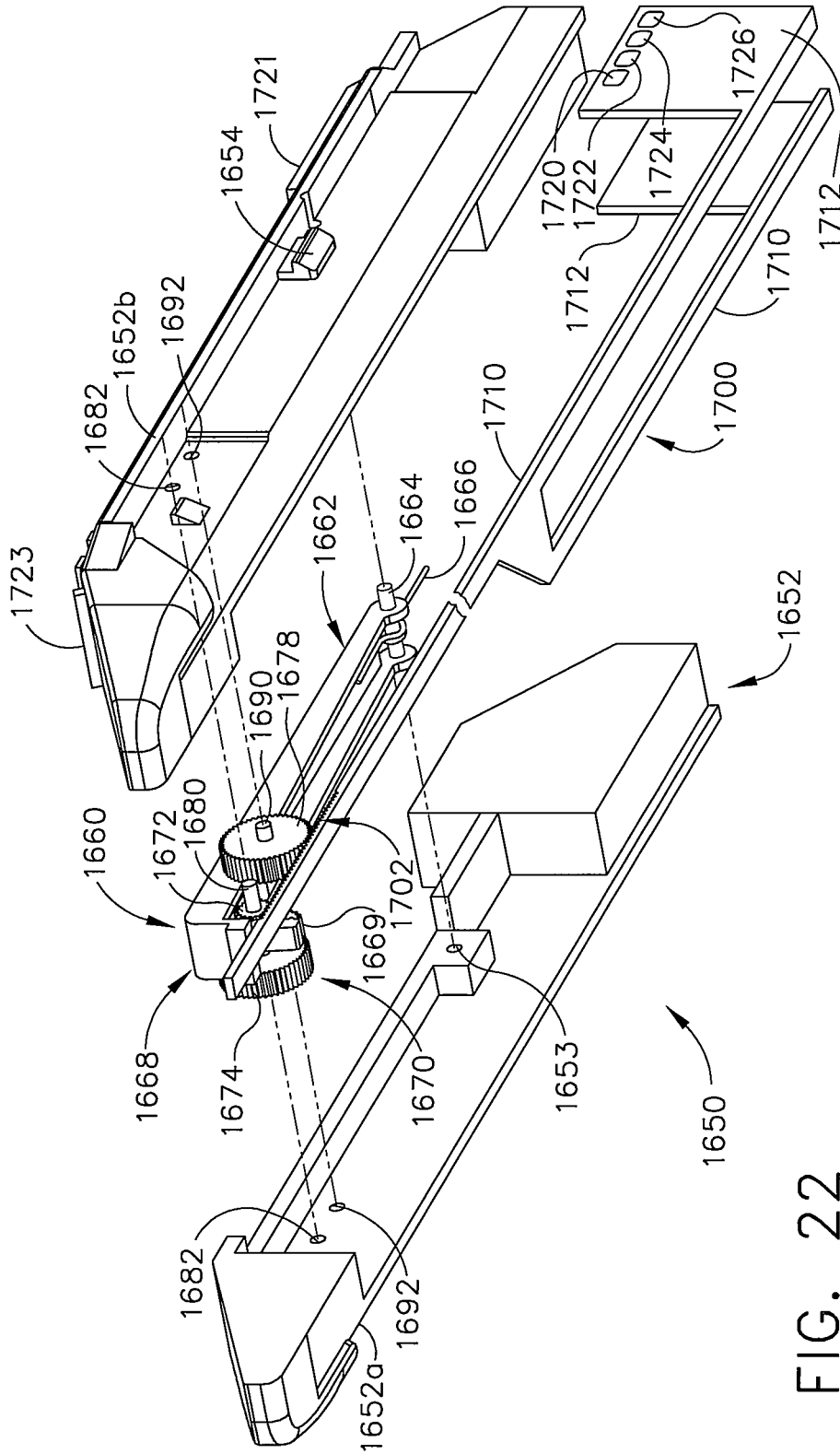

FIG. 22

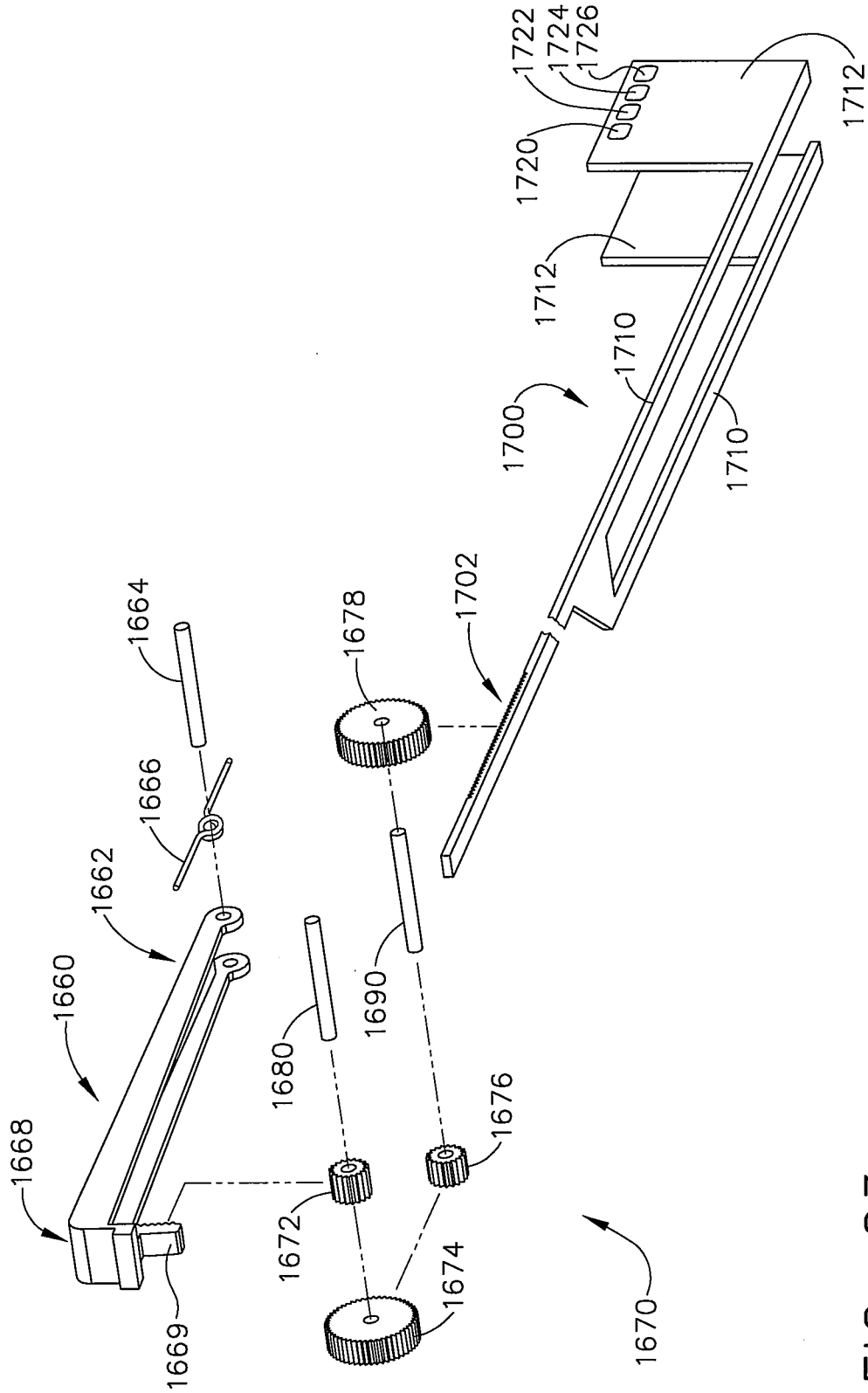

FIG. 23

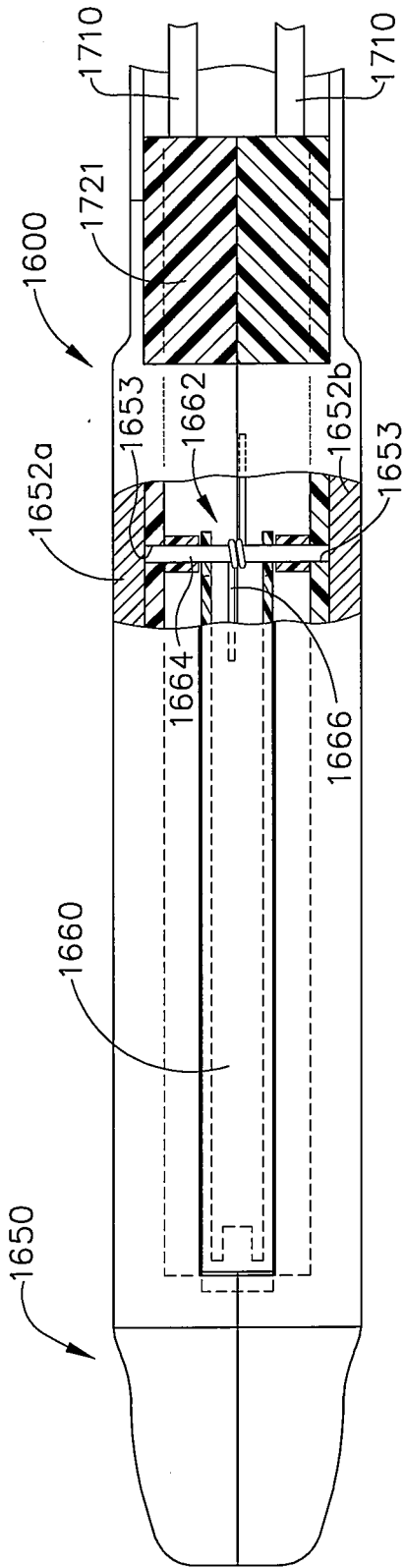

FIG. 24

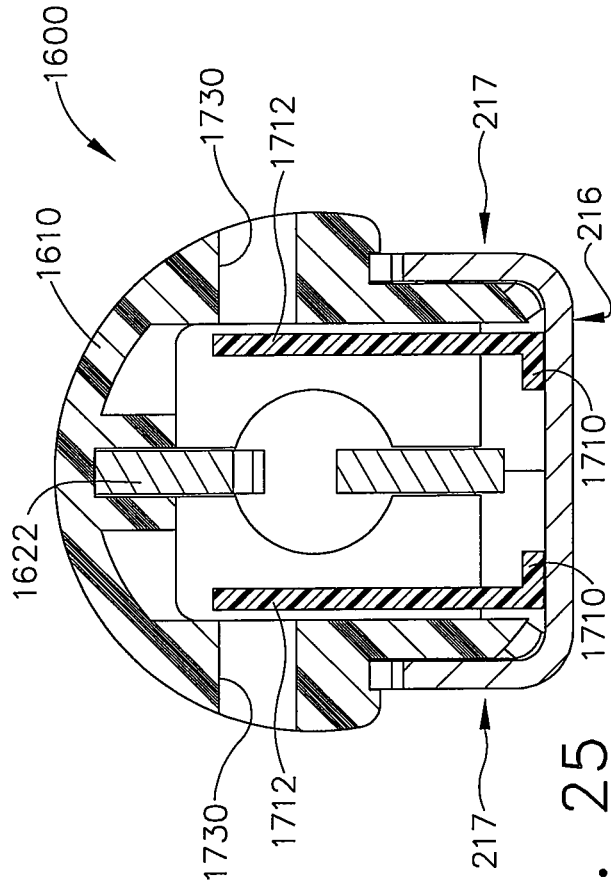

FIG. 25

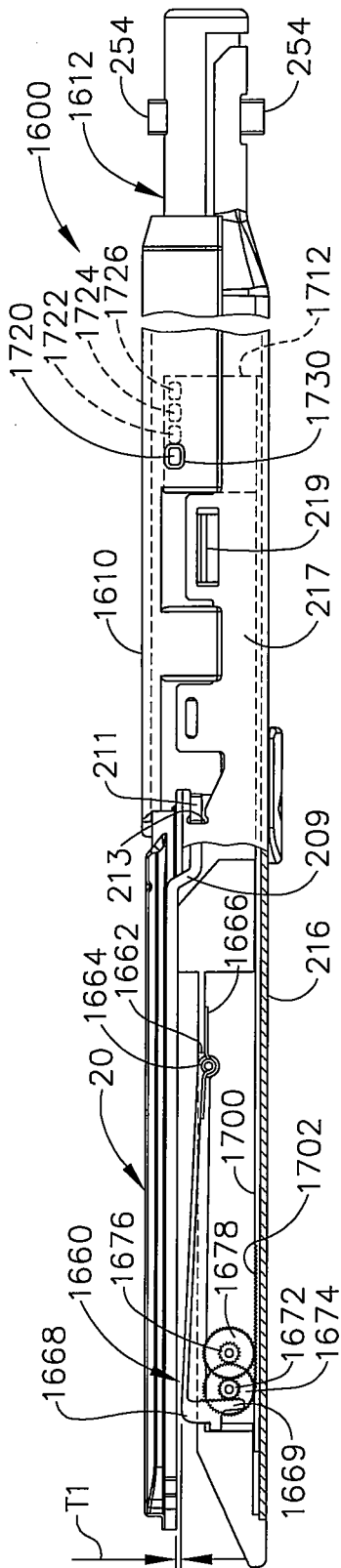

FIG. 26

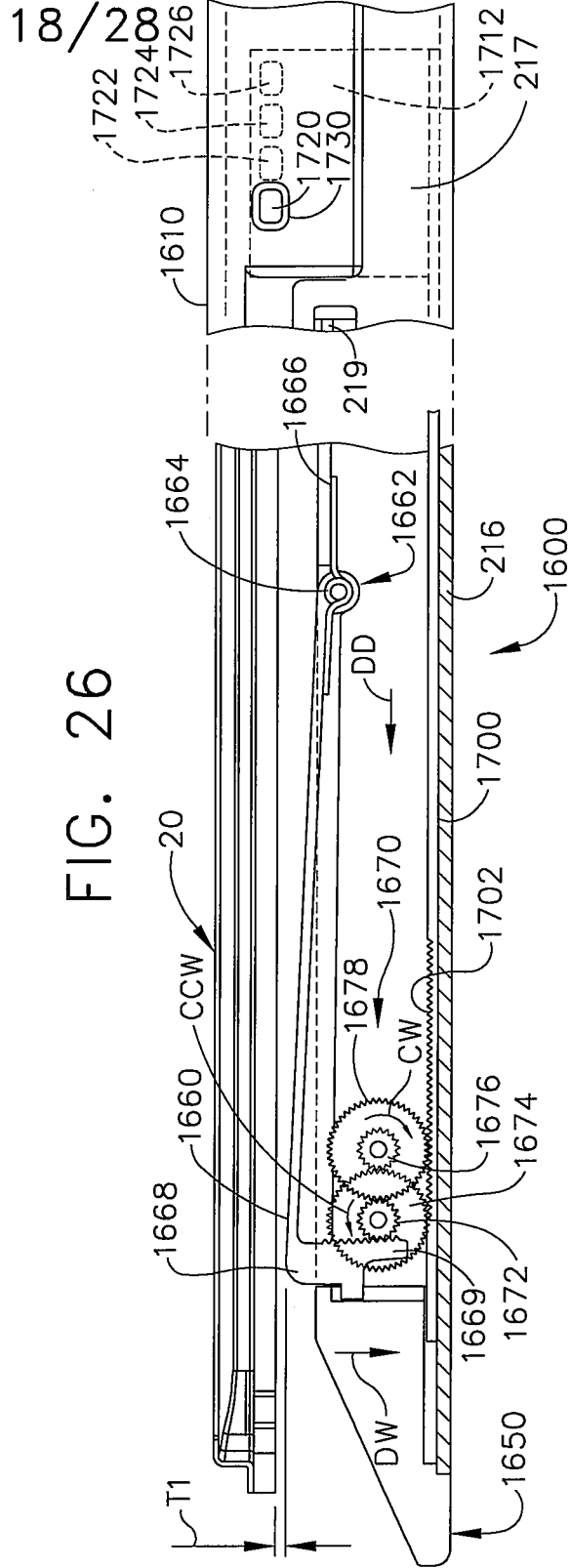

FIG. 27

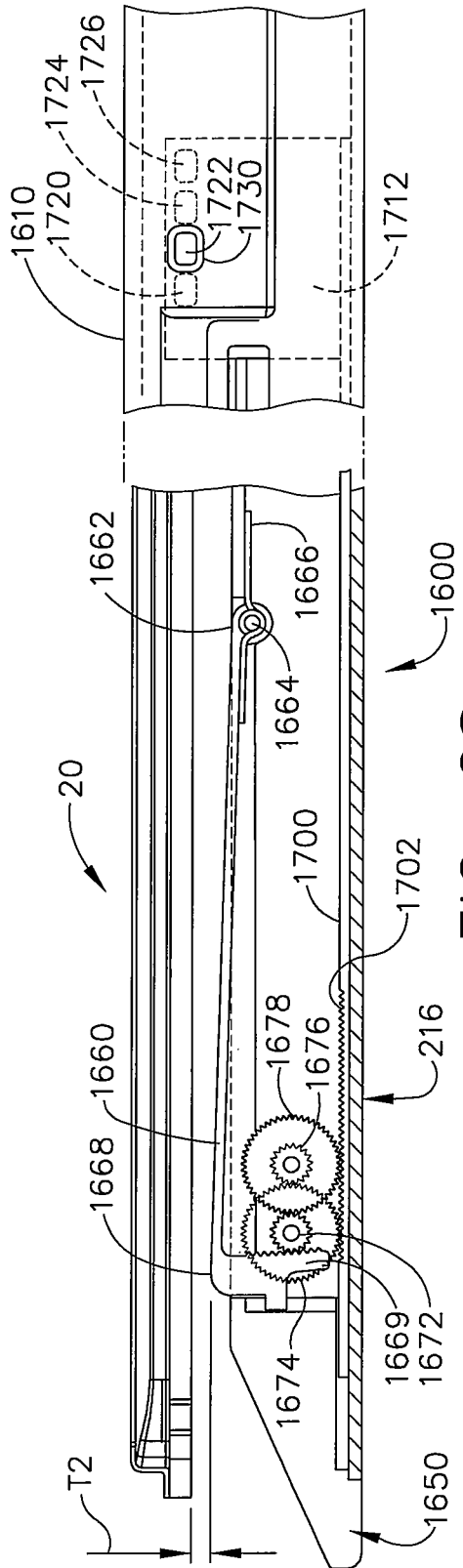

FIG. 28

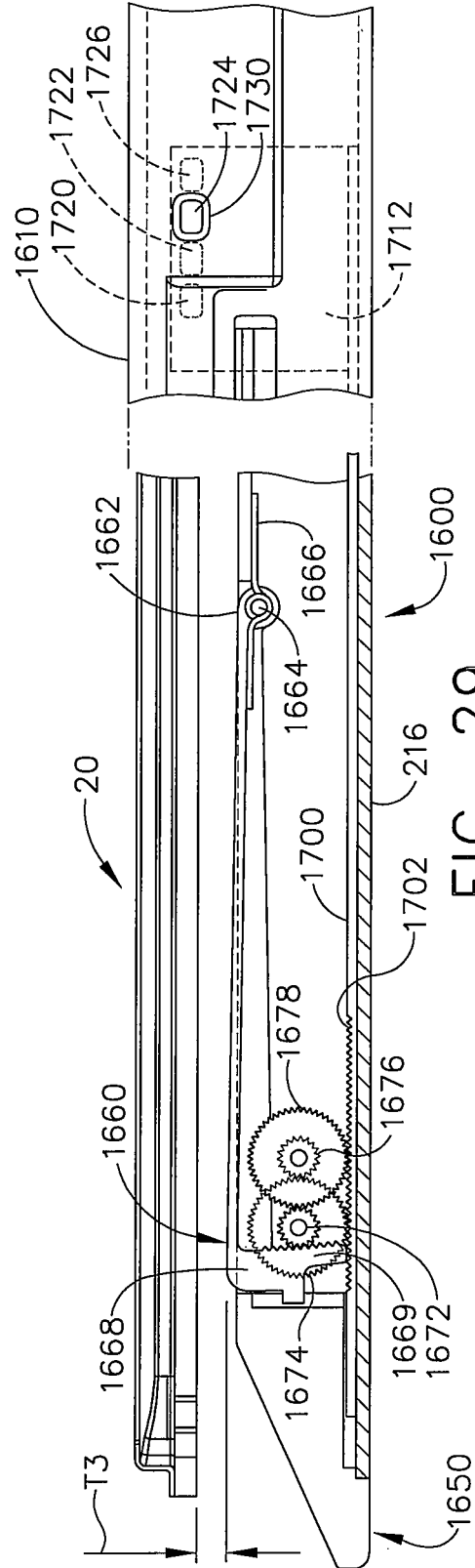

FIG. 29

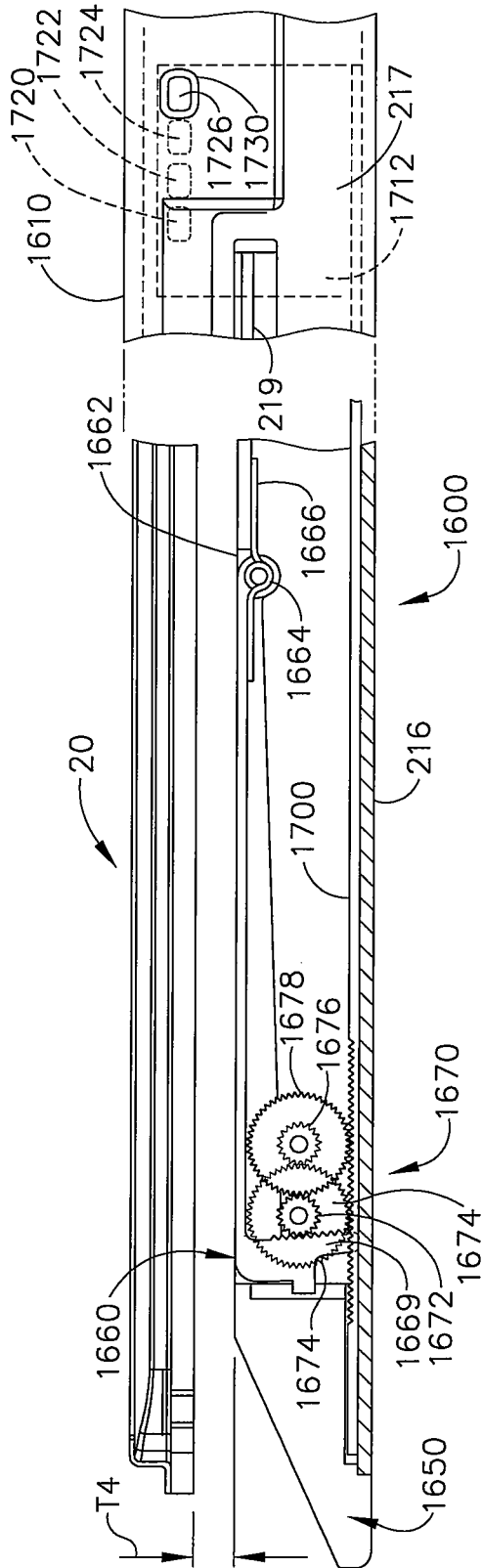

FIG. 30

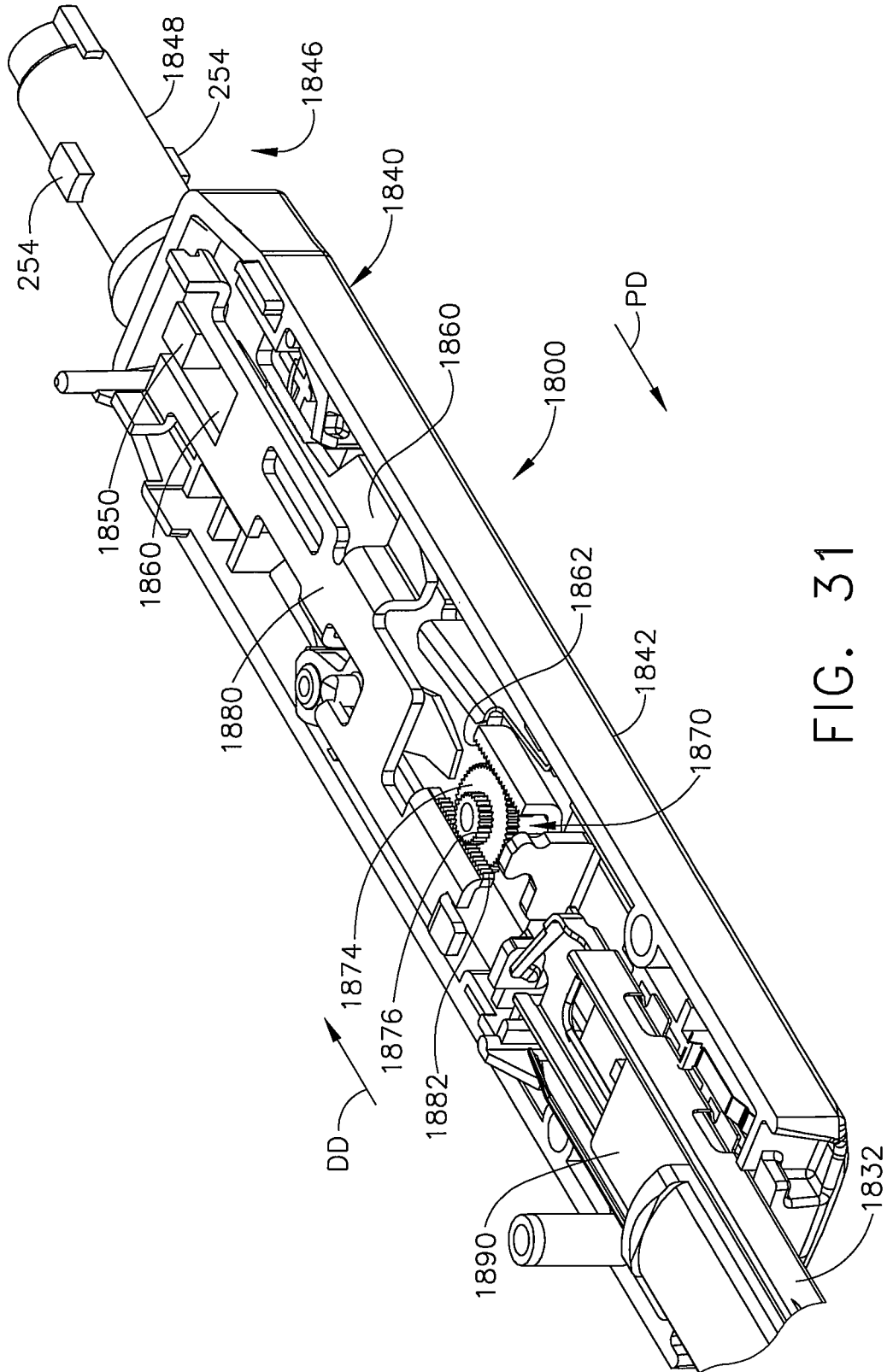

FIG. 31

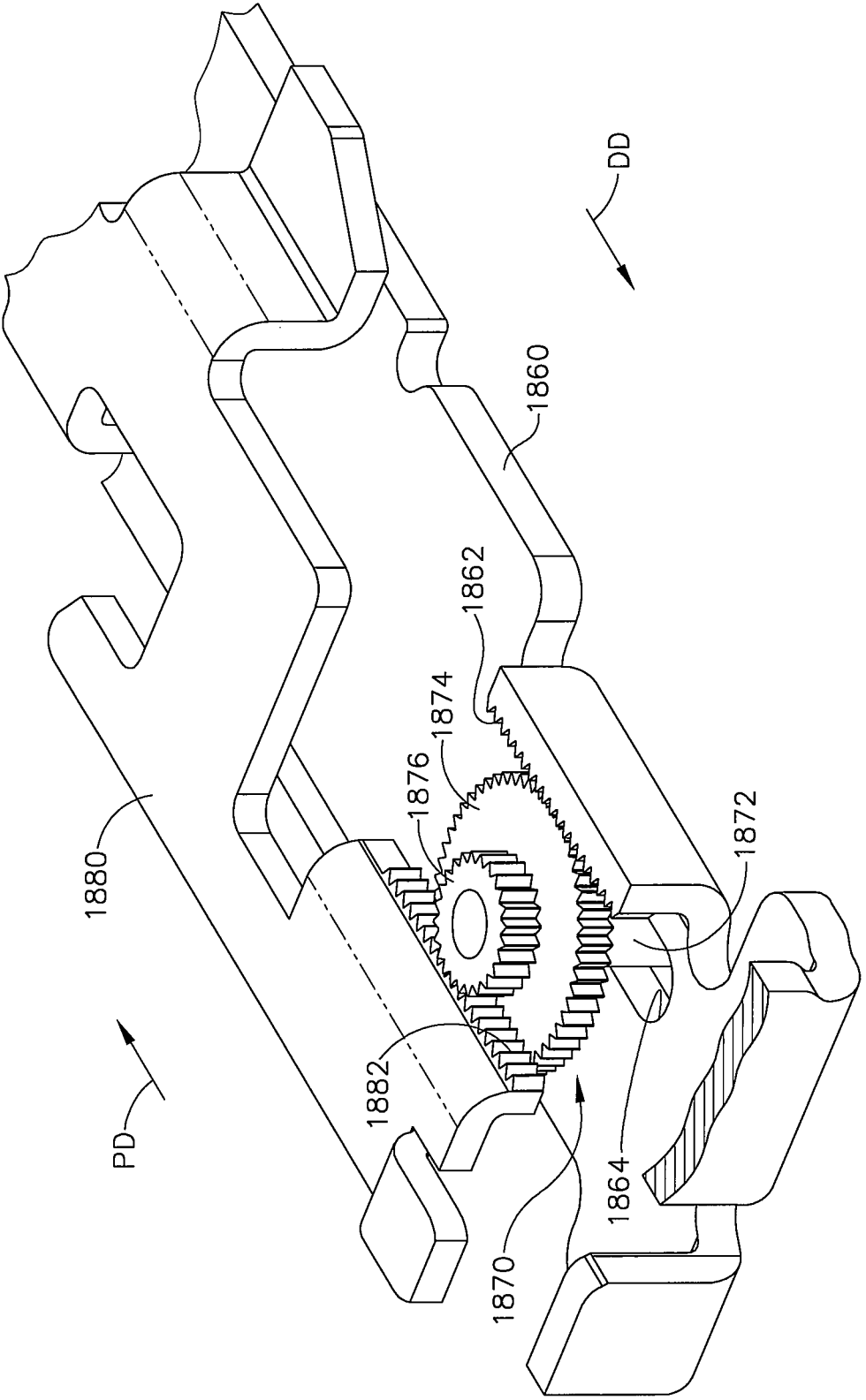

FIG. 32

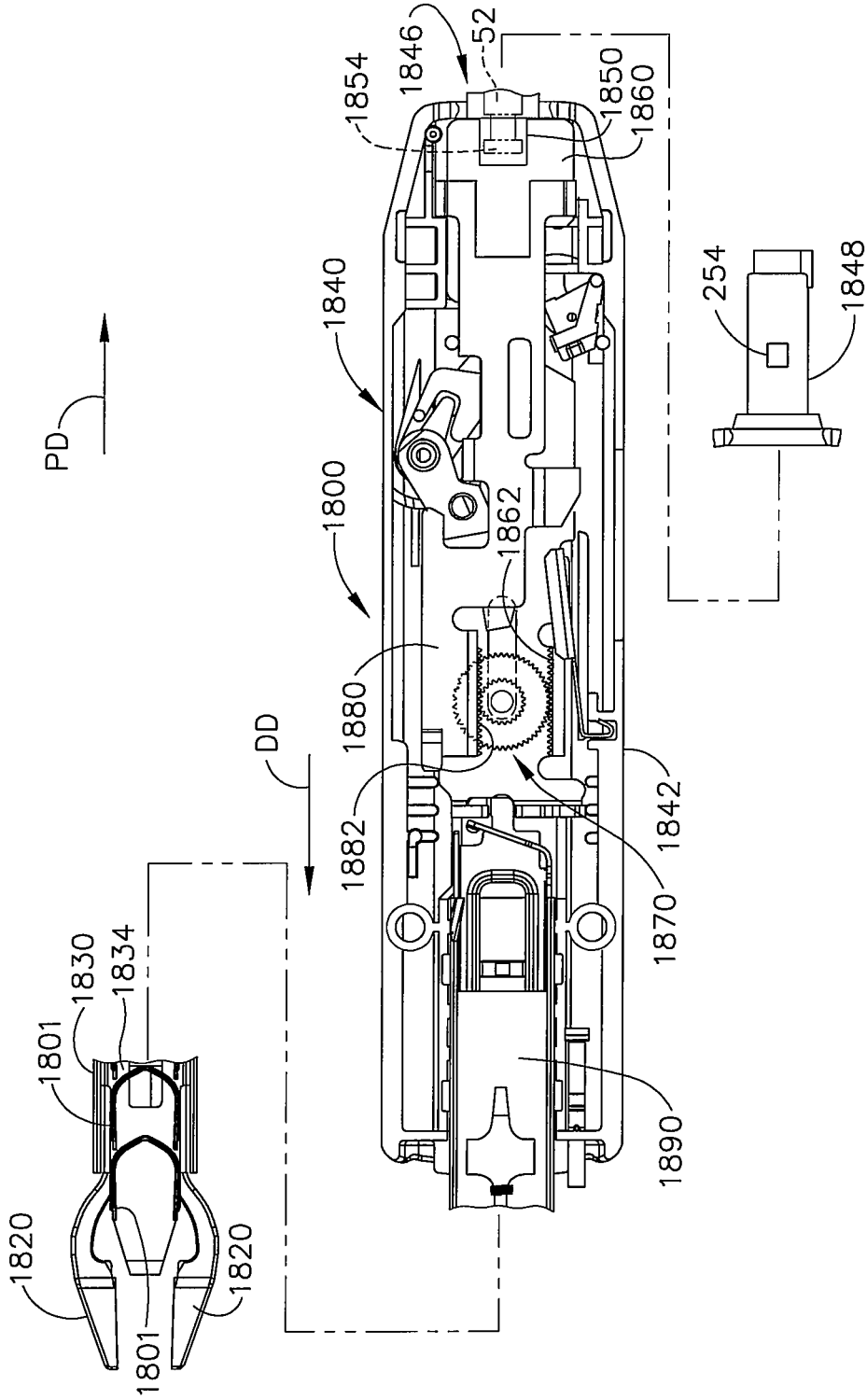

FIG. 33

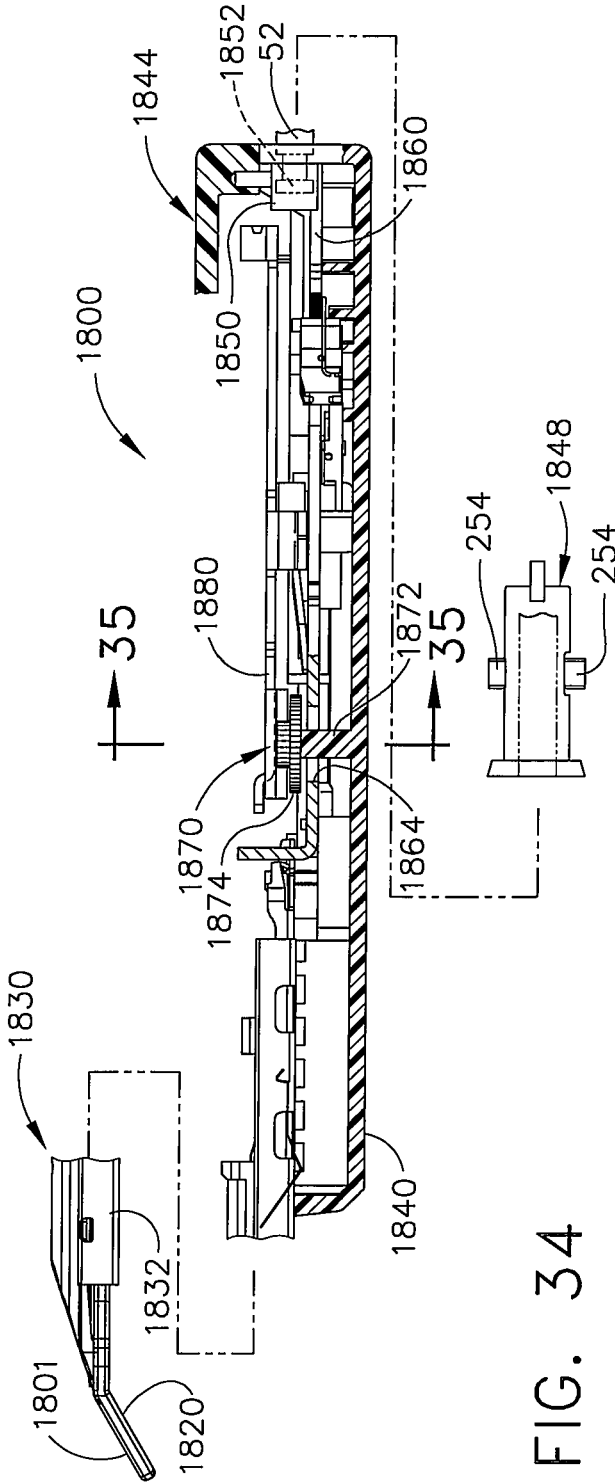

FIG. 34

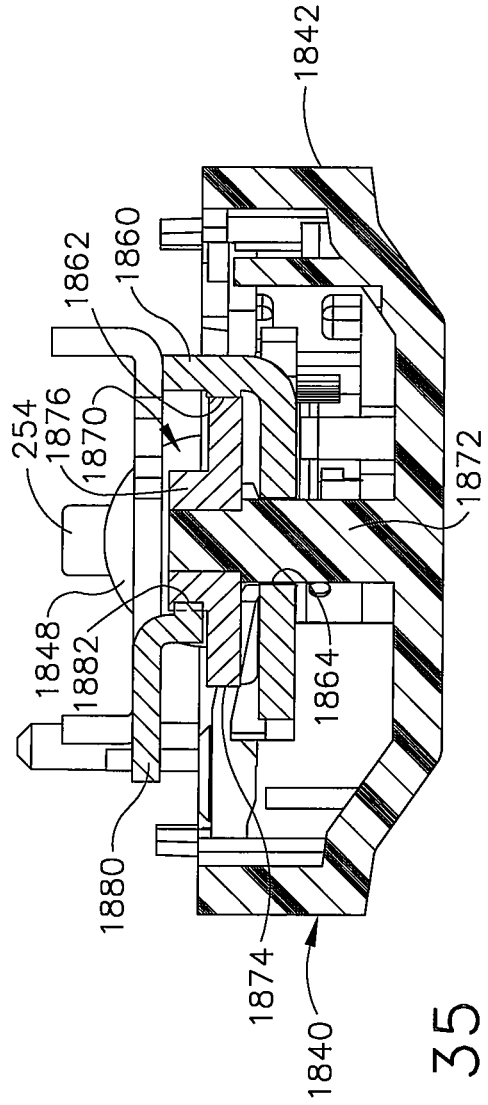

FIG. 35

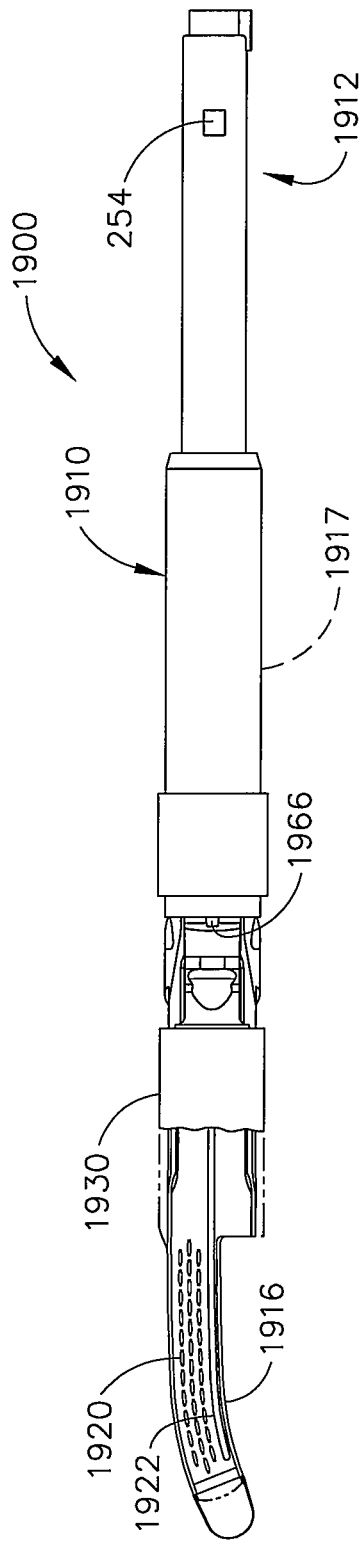

FIG. 36

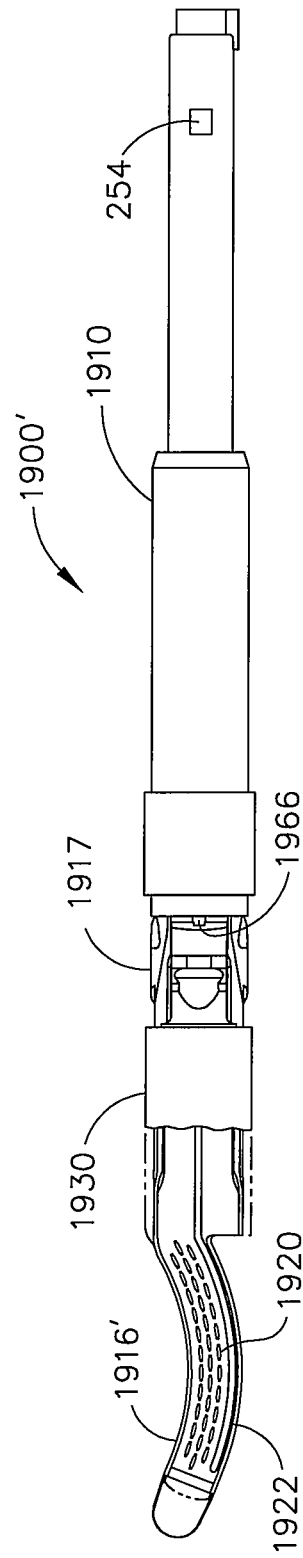
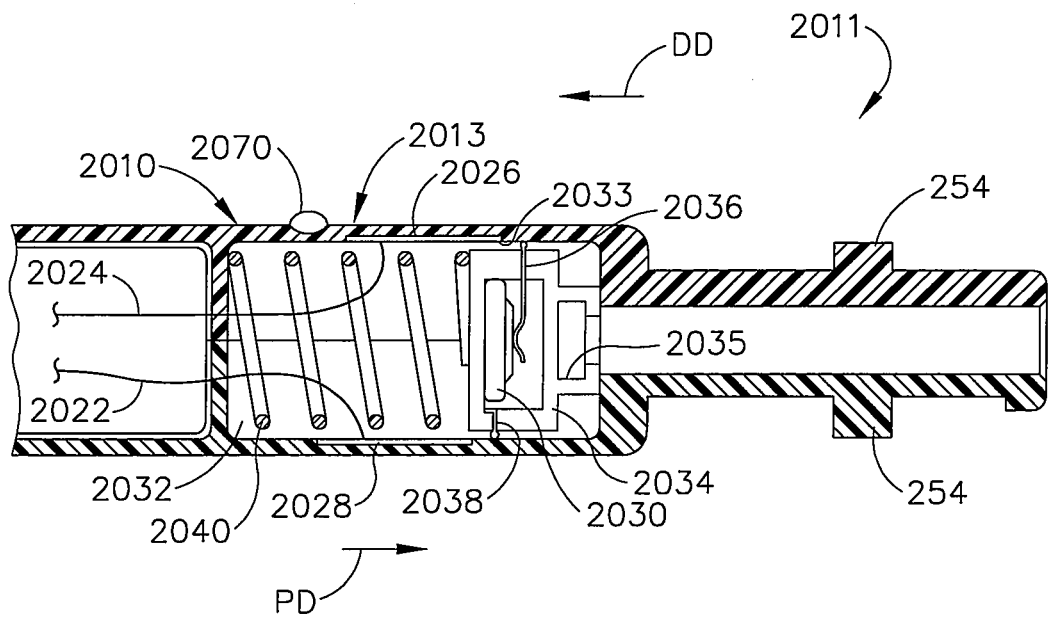
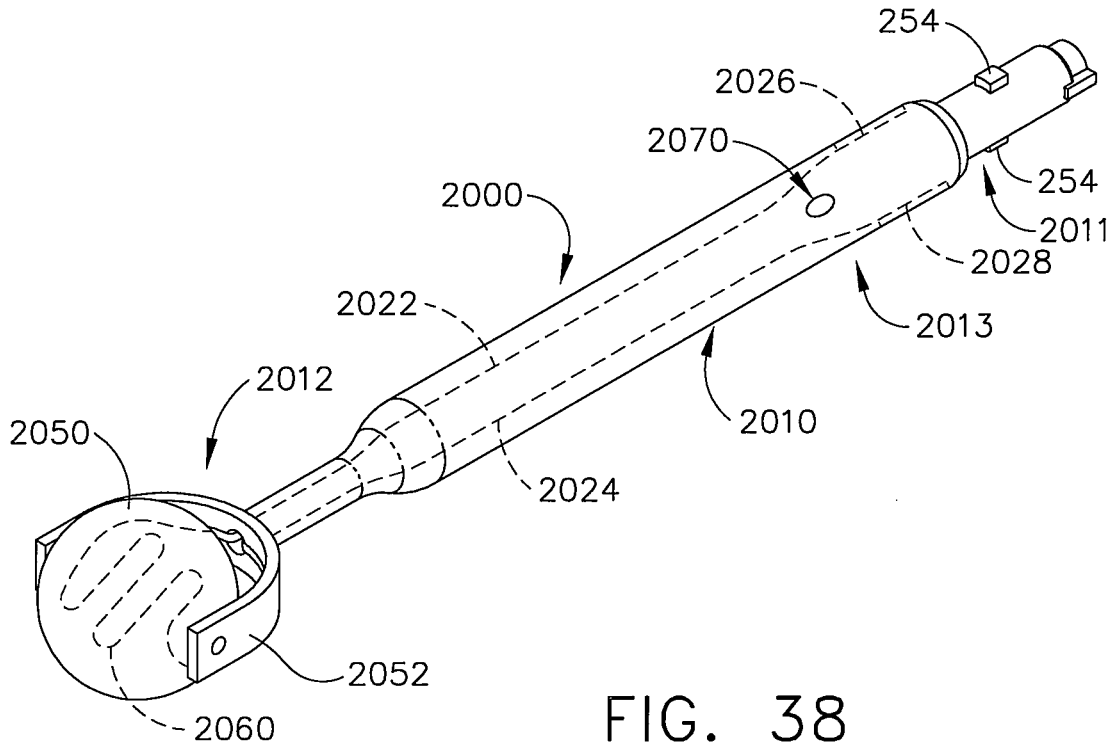

FIG. 37



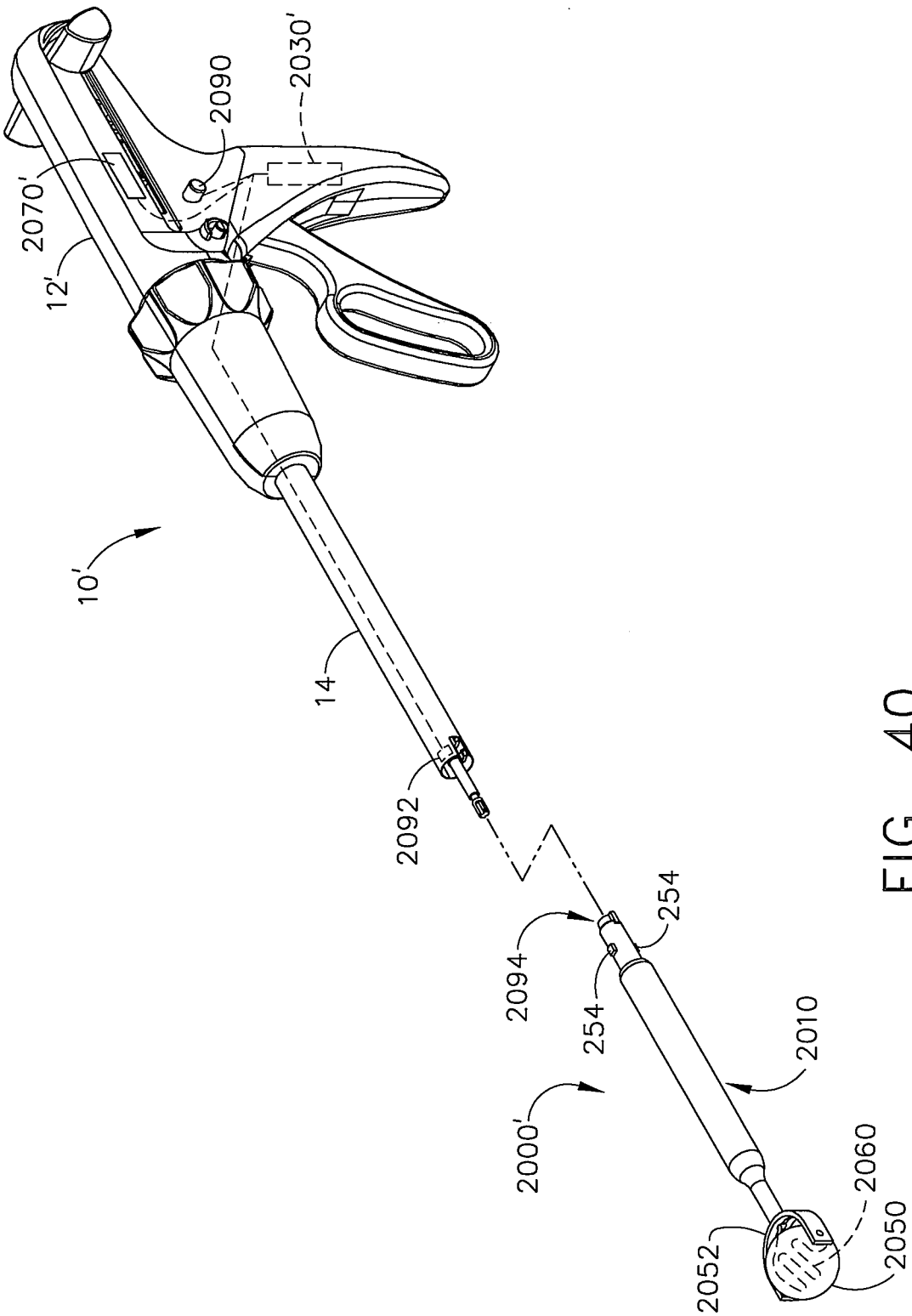
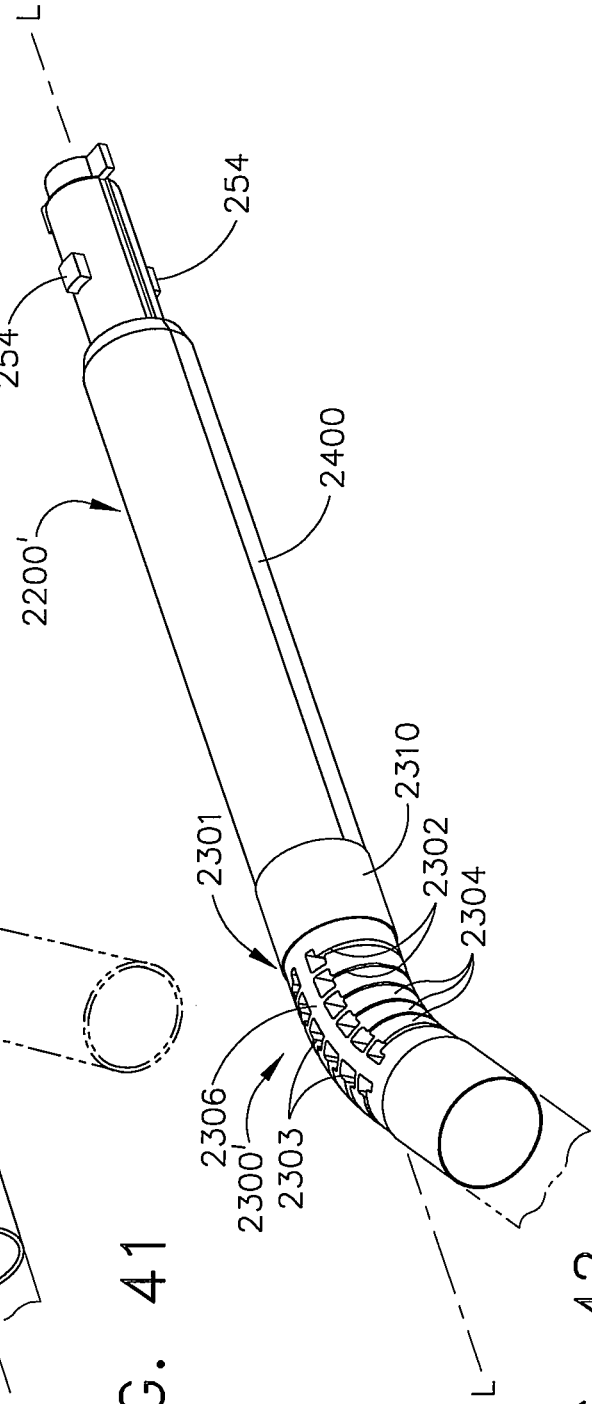
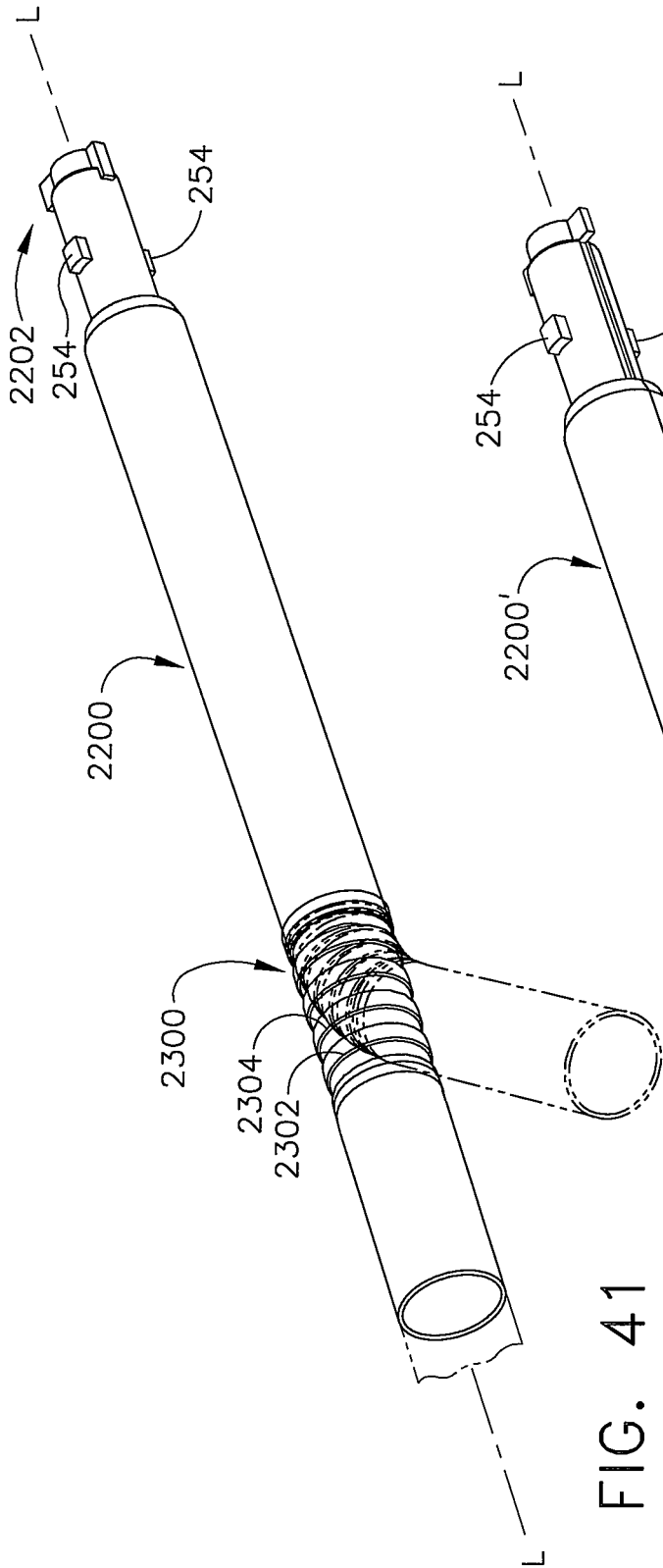

FIG. 40



INTERCHANGEABLE TOOLS FOR SURGICAL INSTRUMENTS

CROSS-REFERENCE TO RELATED APPLICATIONS

[0001] This application is a continuation application claiming priority under 35 U.S.C. § 120 to U.S. patent application Ser. No. 15/804,160, entitled INTERCHANGEABLE TOOLS FOR SURGICAL INSTRUMENTS, filed Nov. 6, 2017, now U.S. Patent Application Publication No. 2018/0078248, which is a continuation application claiming priority under 35 U.S.C. § 120 to U.S. patent application Ser. No. 14/272,197, entitled INTERCHANGEABLE TOOLS FOR SURGICAL INSTRUMENTS, filed May 7, 2014, now U.S. Patent Application Publication No. 2014/0243865, which is a continuation application claiming priority under 35 U.S.C. § 120 to U.S. patent application Ser. No. 12/031,611, entitled INTERCHANGEABLE TOOLS FOR SURGICAL INSTRUMENTS, filed Feb. 14, 2008, which issued on Jun. 24, 2014 as U.S. Pat. No. 8,758,391, the entire disclosures of which are hereby incorporated by reference herein.

FIELD OF THE INVENTION

[0002] The present invention relates in general to surgical instruments including, but not limited to, surgical instruments normally used with disposable cutting and stapling units that are capable of applying lines of staples to tissue while cutting the tissue between those staple lines and, more particularly, to a collection of interchangeable tools for use with such instruments.

COMMONLY-OWNED PATENT APPLICATIONS

[0003] The Assignee of the subject application also co-owns the following U.S. Patent Applications which are herein incorporated by reference:

[0004] U.S. patent application Ser. No. 11/729,008, entitled LAPAROSCOPIC TISSUE THICKNESS AND CLAMP LOAD MEASURING DEVICES, filed Mar. 28, 2007, now U.S. Pat. No. 8,893,946;

[0005] U.S. patent application Ser. No. 11/652,170, entitled SURGICAL STAPLER WITH TAPERED DISTAL END, filed Jan. 11, 2007, now U.S. Patent Application Publication No. 2008/0169333;

[0006] U.S. patent application Ser. No. 12/031,628, entitled DISPOSABLE MOTOR DRIVEN LOADING UNIT FOR USE WITH A SURGICAL CUTTING AND STAPLING APPARATUS; filed Feb. 14, 2008, now U.S. Pat. No. 7,793,812; and

[0007] U.S. patent application Ser. No. 12/031,001, entitled ARTICULATABLE LOADING UNITS FOR SURGICAL STAPLING AND CUTTING INSTRUMENTS, filed Feb. 14, 2008, now U.S. Patent Application Publication No. 2009/0206133.

BACKGROUND

[0008] Endoscopic surgeries are often preferred over traditional open surgical procedures because the smaller incision required by endoscopic surgical procedures tends to reduce the post-operative recovery time and complications. A variety of surgical procedures are currently performed by laparoscopic or other endoscopic techniques. Such procedures may include, for example, intestinal and stomach

operations such as removal of colon cancer, hernia repairs, stomach stapling, removal of gall bladder, Ob/Gyn related surgeries as well as other procedures, such as those involving manipulations of a patient's spleen, liver, lung, heart, etc.

[0009] Consequently, significant development has gone into a range of endoscopic surgical instruments that are suitable for precise placement of a distal end effector at a desired surgical site through a cannula of a trocar that has been inserted into a patient. These distal end effectors engage or interact with the tissue in a number of ways to achieve a desired diagnostic or therapeutic effect. Such devices are often configured to perform a single type of surgical action (e.g., endocutter, grasper, cutter, staplers, clip applicator, access device, drug/gene therapy delivery device, and energy device using ultrasound, RF, laser, etc.) which often requires the clinician to use several different instruments that are each only adapted to perform one action during a single operation. For example, U.S. Pat. Nos. 5,352,235; 5,383,895; and 5,728,121 each disclose dedicated grasping instruments that may be used for endoscopic and laparoscopic procedures. For those procedures requiring the removal of tissue or specimens from the body (e.g., removal of a diseased gall bladder, appendix, etc.), dedicated specimen retrieval instruments such as those disclosed in U.S. Pat. No. 6,406,440 have been developed. For procedures requiring the cutting and severing of tissue, dedicated scissor instruments such as those described in U.S. Pat. No. 6,168,605 have also been developed.

[0010] For those procedures involving the cutting and stapling of tissue, various surgical stapling devices have been designed. Such surgical stapling devices commonly include an end effector that simultaneously makes a longitudinal incision in tissue and applies lines of staples on opposing sides of the incision. The end effector includes a pair of cooperating jaw members that, if the instrument is intended for endoscopic or laparoscopic applications, are capable of passing through a cannula passageway. One form of surgical cutting and stapling device is disclosed in U.S. Pat. No. 6,905,057. Such devices have a dedicated reusable drive and knife beam and are designed to be used with replaceable staple cartridges. Removable cartridges constructed to measure tissue thickness such as those disclosed in U.S. patent application Ser. No. 11/729,008, entitled LAPAROSCOPIC TISSUE THICKNESS AND CLAMP LOAD MEASURING DEVICES, now U.S. Pat. No. 8,893,946, have also been designed for use with such instruments. Alternative curved end effector arrangements such as those disclosed in U.S. patent application Ser. No. 11/652,170, entitled SURGICAL STAPLER WITH TAPERED DISTAL END, now U.S. Patent Application Publication 2008/0169333, also have dedicated reusable knife and drive beam arrangements for use with removable/replaceable staple cartridges.

[0011] Other types of surgical stapling devices such as those disclosed in U.S. Pat. No. 5,865,361 are configured to operate with disposable loading units (DLU's) that are constructed to support a dedicated staple cartridge and knife assembly therein. Once the procedure is completed, the entire DLU is discarded. Such instruments that are designed to accommodate DLU's purport to offer the advantage of a "fresh" knife blade for each firing of the instrument. The reusable hand piece portion of such surgical stapling instruments was limited to use in connection with disposable loading units that were constructed to cut and staple tissue.

Thus, for operations that involve various actions and procedures (e.g., grasping and manipulating tissue, cutting tissue, removal of tissue, applying clips and/or staples, cauterization of tissue, delivery of drugs and medicaments, etc.) a collection of different surgical instruments that are designed specifically to perform one of those actions in the past were required to be on hand.

[0012] Thus, there is a need for different types of interchangeable surgical tool attachments that may be used with a single surgical instrument hand piece.

SUMMARY

[0013] In one general aspect of various embodiments of the present invention, there is provided a surgical tool for use with a surgical instrument that has a handle assembly that operably supports a drive system therein for generating drive motions upon actuation of a movable handle portion thereof. The surgical instrument further has an elongated body that operably supports a control rod therein for transferring the drive motions. Various embodiments of the surgical tool comprise a housing that is removably couplable to the elongated body. A drive assembly may be operably supported in the housing and is removably couplable to the control rod. A pair of non-staple forming jaws are operably coupled to the drive assembly such that upon application of a drive motion to the drive assembly in a first direction the non-staple forming jaws each simultaneously move in a closing direction toward each other and upon application of another drive motion in a second direction, the non-staple forming jaws each simultaneously move in an opening direction away from each other.

[0014] In still another general aspect of various embodiments of the present invention, there is provided a surgical tool for use with a surgical instrument that has a handle assembly that operably supports a drive system therein for generating drive motions upon actuation of a movable handle portion thereof. The surgical instrument may further have an elongated body that operably supports a control rod therein for transferring the drive motions. Various embodiments of the surgical tool may comprise a carrier that has a housing coupled thereto. The housing may be movably couplable to the elongated body. A drive assembly may be operably supported in the housing and carrier and be removably couplable to the control rod. A non-staple forming anvil may be movably supported on the carrier and configured to operably interact with the drive assembly to selectively move the non-staple forming anvil toward and away from the carrier. A tissue thickness measuring cartridge may be supported in the carrier. The tissue thickness measuring cartridge may have an indicator member that interacts with the housing to provide an indication of a thickness range of tissue clamped between the non-staple forming anvil and the tissue thickness measuring cartridge.

[0015] In another general aspect of various embodiments of the present invention, there is provided a surgical tool for use with a surgical instrument that has a handle assembly that operably supports a drive system therein for generating drive motions upon actuation of a movable handle portion thereof. The surgical instrument may further have an elongated body that operably supports a control rod therein for transferring the drive motions. In various embodiments, the surgical tool comprises a housing that is directly couplable to the elongated body. A drive assembly may be operably supported in the housing and carrier. The drive assembly

may be removably couplable to the control rod. A staple-forming anvil may be non-movably supported by the housing. A plurality of staples may be supported in a distal end of the housing and be oriented to be sequentially driven into the staple-forming anvil upon application of a drive motion to the drive assembly.

[0016] In another general aspect of various embodiments of the present invention, there is provided a surgical tool for use with a surgical instrument that has a handle assembly that operably supports a drive system therein for generating drive motions upon actuation of a movable handle portion thereof. The surgical instrument may further have an elongated body that operably supports a control rod therein for transferring the drive motions. In various embodiments, the surgical tool comprises a housing that is directly couplable to the elongated body. A pair of opposed, moveable jaws may be attached to and extend from the shaft. The jaws are configured to receive each of the surgical clips serially therein when the jaws are in an open position. The jaws may also form each of the surgical clips received serially therein when the jaws are moved to a closed position. A moveable forming mechanism may be removably couplable to the control rod when the housing is coupled to the elongated body. The forming mechanism may be configured to move the jaws from the open position to the closed position upon application of a first drive motion from the control rod so as to form each of the surgical clips received serially therein. The forming mechanism may be further configured to move from the closed position to the open position upon application of a second drive motion to the forming mechanism by the control rod. A feeding mechanism may operatively interact with the movable forming mechanism. The feeding mechanism may have a feed plate that is movable in response to movement of the forming mechanism and may be releasably coupled to a clip pusher of the feed mechanism. The clip pusher may be stationary and uncoupled from the feed plate upon application of the first drive motion to the forming mechanism. The clip pusher may be moveable and operatively coupled to the feed plate upon application of the second drive motion to the movable forming mechanism so as to move each of the surgical clips serially from the shaft into the jaws.

[0017] In connection with another general aspect of the present invention there is provided a surgical tool for use with a surgical instrument that has a handle assembly that operably supports a drive system therein for generating drive motions upon actuation of a movable handle portion thereof. The surgical instrument may further have an elongated body that operably supports a control rod therein for transferring the drive motions. Various embodiments of the surgical tool of the present invention may comprise a carrier that has a housing coupled thereto. The housing may be removably couplable to the elongated body. A drive assembly may be operably supported in the housing and carrier and also be removably couplable to the control rod. A staple forming anvil may be movably supported on the carrier and operably interact with the drive assembly to selectively move the staple forming anvil toward and away from the carrier. A staple-supporting cartridge that has a radius of curvature may be supported in the carrier. The staple-supporting cartridge may have a curved slot therethrough defining a curved passage for receiving a distal end of the drive assembly therethrough upon application of a drive motion thereto.

[0018] In accordance with another general aspect of the present invention there is provided a surgical tool for use with a surgical instrument that has a handle assembly that operably supports a drive system therein for generating drive motions upon actuation of a movable handle portion thereof. An elongated body may operably support a control rod therein for transferring the drive motions. Various embodiments of the surgical tools may comprise a housing that is removably couplable to the elongated body. A syringe body may be coupled to the housing. A hollow needle may protrude from the syringe body. A drive assembly may be operably supported in the housing and may be removably couplable to the control rod. A syringe plunger may be movably supported in the syringe body and may be coupled to the drive assembly for selective movement therewith.

[0019] In accordance with still another general aspect of the present invention there is provided a surgical tool for use with a surgical instrument that has a handle assembly that operably supports a drive system therein for generating drive motions upon actuation of a movable handle portion thereof. An elongated body may operably support a control rod therein for transferring the drive motions. Various embodiments of the surgical tool may comprise a housing that is removably couplable to the elongated body. A non-staple applying end effector may operably protrude from a distal end of the housing. The non-staple applying end effector may support at least one electrically powered member. A battery may be movably supported within the housing and be configured to electrically communicate with the at least one electrically powered member. The battery may be removably couplable to the control rod such that upon application of a first drive motion thereto, the battery applies power to the electrical powered member and, upon application of a second drive motion thereto, the battery discontinues the application of power to the electrically powered member.

[0020] In accordance with another general aspect of the present invention there is provided a surgical tool system that includes a surgical instrument that may comprise a handle assembly that has a drive system operably supported therein for generating drive motions upon actuation of a movable handle portion that is operably coupled to the handle assembly. An elongated body may protrude from the handle assembly and a control rod may be operably supported in the elongated body. The control rod may interface with the drive system for receiving the drive motions therefrom. The system may further include at least two surgical tools that are selected from the group of surgical tools consisting of: manipulators, nippers, scissors, endcutters, tissue thickness measurement devices, staple appliers, clip appliers, syringe glue/sealant/drug/medicament appliers and cauterization devices wherein each surgical tool within the group of surgical tools at least has a housing that is removably couplable to the elongated body and a drive assembly that is removably couplable to the control rod for receiving the drive motions therefrom.

[0021] These and other objects and advantages of the present invention shall be made apparent from the accompanying drawings and the description thereof.

BRIEF DESCRIPTION OF THE FIGURES

[0022] The accompanying drawings, which are incorporated in and constitute a part of this specification, illustrate embodiments of the invention, and, together with the general

description of various embodiments of the invention given above, and the detailed description of the embodiments given below, serve to explain various principles of the present invention.

[0023] FIG. 1 is a perspective view of a prior surgical cutting and stapling apparatus.

[0024] FIG. 2 is a side view of a surgical tool embodiment of the present invention.

[0025] FIG. 3 is a cross-sectional view of the surgical tool embodiment of FIG. 2 with some components thereof shown in full view for clarity.

[0026] FIG. 4 is another cross-sectional view of the surgical tool embodiment of FIGS. 2 and 3 in a closed position.

[0027] FIG. 5 is a perspective view showing one exemplary use of the surgical tool embodiment of FIGS. 2-4 in connection with another surgical tool embodiment of the present invention for removing tissue from a patient.

[0028] FIG. 6 is a cross-sectional view of another surgical tool embodiment of the present invention with some components thereof shown in full view for clarity.

[0029] FIG. 7 is a perspective view of another surgical tool embodiment of the present invention.

[0030] FIG. 8 is a perspective view of another surgical tool embodiment of the present invention.

[0031] FIG. 9 is a cross-sectional view of the surgical tool embodiment of FIG. 8.

[0032] FIG. 10 is an enlarged cross-sectional view of the distal end of the surgical tool of FIGS. 8 and 9 in a pre-fired position.

[0033] FIG. 11 is another enlarged cross-sectional view of the distal end of the surgical tool of FIGS. 8-10 wherein a staple is being fired into tissue.

[0034] FIG. 12 is another enlarged cross-sectional view of the distal end of the surgical tool of FIGS. 8-11 after a first staple has been fired.

[0035] FIG. 13 is a perspective view of another surgical tool embodiment of the present invention.

[0036] FIG. 14 is a cross-sectional view of the surgical tool embodiment of FIG. 13 with some components thereof shown in full view for clarity.

[0037] FIG. 15 is a perspective view of another surgical tool embodiment of the present invention.

[0038] FIG. 16 is an exploded assembly view of a portion of the surgical tool embodiment of FIG. 15.

[0039] FIG. 17 is a side elevational view of the surgical tool embodiment of FIGS. 15 and 16 with the anvil assembly in an open position.

[0040] FIG. 18 is another side elevational view of the surgical tool embodiment of FIGS. 15 and 16 with a portion thereof shown in cross-section and with the anvil assembly shown in a first closed position with no tissue clamped therein.

[0041] FIG. 19 is an enlarged view of the distal end of the surgical tool embodiment depicted in FIG. 18.

[0042] FIG. 20 is a cross-sectional view of the surgical tool of FIG. 18 taken along line 20-20 in FIG. 18.

[0043] FIG. 21 is an enlarged view of the distal end portion of the surgical tool shown in FIG. 20.

[0044] FIG. 22 is an exploded assembly view of a thickness measurement cartridge portion of the surgical tool of FIGS. 15-21.

[0045] FIG. 23 is another exploded assembly view of portions of the thickness measurement cartridge of FIG. 21.

[0046] FIG. 24 is a cross-sectional view of a portion of the surgical tool of FIG. 17 taken along line 24-24 in FIG. 17.

[0047] FIG. 25 is a cross-sectional view of a portion of the surgical tool of FIG. 17 taken along line 25-25 in FIG. 17.

[0048] FIG. 26 is a side elevational view of the surgical tool embodiment of FIGS. 15-25 with anvil assembly in a closed position for clamping tissue having a first thickness range therein.

[0049] FIG. 27 is an enlarged view of the distal end of the surgical tool embodiment depicted in FIG. 26.

[0050] FIG. 28 is a side elevational view of the surgical tool embodiment of FIGS. 15-27 with the anvil assembly in a closed position for clamping tissue having a second thickness range therein.

[0051] FIG. 29 is a side elevational view of the surgical tool embodiment of FIGS. 15-28 with the anvil assembly in a closed position for clamping tissue having a third thickness range therein.

[0052] FIG. 30 is a side elevational view of the surgical tool embodiment of FIGS. 15-29 with the anvil assembly in a closed position for clamping tissue having a fourth thickness range therein.

[0053] FIG. 31 is a perspective view of a portion of another surgical tool embodiment of the present invention with the cover removed therefrom.

[0054] FIG. 32 is a perspective view of portions of a forming plate and feed plate arrangement of the surgical tool of FIG. 31.

[0055] FIG. 33 is a plan view of the surgical tool embodiment of FIG. 31 with the cover removed for clarity.

[0056] FIG. 34 is a cross-sectional view of the surgical tool of FIGS. 31-33.

[0057] FIG. 35 is a cross-sectional view of the surgical tool of FIG. 34 taken along lines 35-35 in FIG. 34.

[0058] FIG. 36 is a plan view of another surgical tool embodiment of the present invention with a portion of the anvil assembly omitted for clarity.

[0059] FIG. 37 is a plan view of another surgical tool embodiment of the present invention with a portion of the anvil assembly omitted for clarity.

[0060] FIG. 38 is a perspective view of another surgical tool embodiment of the present invention.

[0061] FIG. 39 is a cross-sectional view of a portion of the housing of the surgical tool of FIG. 38.

[0062] FIG. 40 is an exploded assembly view of another surgical tool embodiment of the present invention used in connection with another surgical instrument embodiment of the present invention.

[0063] FIG. 41 is a perspective view of an alternate housing embodiment of the present invention with a portion thereof shown in phantom lines to illustrate the ability to articulate about an articulation member formed therein.

[0064] FIG. 42 is a perspective view of another alternate housing embodiment of the present invention.

DETAILED DESCRIPTION

[0065] Turning to the Drawings, wherein like numerals denote like components throughout the several views, FIG. 1 depicts a prior surgical instrument 10 that includes a housing assembly 12 and an elongated body 14 that protrudes therefrom. Also shown in FIG. 1 is a prior disposable loading unit 16 that comprises a single-use endocutter for cutting tissue and applying lines of staples on each side of the cut. The disposable loading unit 16 includes a tool

assembly 17 having a cartridge assembly 18 housing a plurality of surgical staples and an anvil assembly 20 movably secured in relation to cartridge assembly 18. In various embodiments, the conventional surgical instrument 10 and the disposable loading unit 16 may comprise the surgical instrument and disposable loading units described in U.S. Pat. No. 5,865,361, entitled SURGICAL STAPLING APPARATUS, issued Feb. 2, 1999, the disclosure of which has been herein incorporated by reference. Thus, the present Detailed Description will not specifically discuss the various components of the surgical instrument 10 and the disposable loading unit 16 and their operation herein beyond what is necessary to describe the operation of the various surgical tool embodiments of the present invention which may be used with a surgical instrument 10.

[0066] As the present Detailed Description proceeds, it will be appreciated that the terms “proximal” and “distal” are used herein with reference to a clinician gripping a handle assembly 12 of the surgical instrument 10 to which a particular surgical tool is operably coupled. Thus, the surgical tool is “distal” with respect to the more proximal handle assembly 12. It will be further appreciated that, for convenience and clarity, spatial terms such as “vertical”, “horizontal”, “up”, “down”, “right”, and “left” are used herein with respect to the drawings. However, surgical tools and instruments are used in many orientations and positions, and these terms are not intended to be limiting and absolute.

[0067] FIGS. 2-4 depict a surgical tool 1000 of an embodiment of the present invention that may be operably coupled to the surgical instrument 10 and used to manipulate tissue, organs, etc. As can be seen in those Figures, the surgical tool 1000 may include a housing 1010 that has a proximal end 1012 that is configured for removable attachment to the elongated body 14 of the surgical instrument 10. In particular, the proximal end 1012 may have engagement nubs 254 formed thereon which serve to form a bayonet-type coupling with the distal end of the elongated body portion 14 of the surgical stapling apparatus as described in U.S. Pat. No. 5,865,361.

[0068] The surgical tool 1000 includes a drive assembly 1020 that may include a proximal drive beam segment 1022 that is coupled to a distal drive beam segment 1030 by a reversing linkage assembly 1040. The drive beam segments 1020, 1030 may each be constructed from a single sheet of material or, preferably, from multiple stacked sheets. However, drive beam segments 1020, 1030 may be fabricated from other suitable materials and arrangements. As can be seen in FIG. 3, the proximal drive beam segment 1022 has an engagement section 1024 formed thereon that may include a pair of engagement fingers 1024a and 1024b that are dimensioned and configured to mountingly engage a drive member 1026. Drive member 1026 includes a proximal porthole 1028 configured to receive the distal end 276 of control rod 52 (See FIG. 1) when the proximal end 1012 of tool attachment 100 is coupled to the elongated body 14 of surgical apparatus 10. As can be seen in FIG. 3, the proximal end 1012 has a hollow passage 1014 therein through which the distal end 276 of the control rod 52 may extend.

[0069] The distal end of the proximal beam segment 1022 has a distally protruding tab 1028 that is pinned to a link 1042 of the reversing linkage assembly 1040. The link 1042 is pivotally attached to the housing 1010 by pin 1044 and is also attached to a proximal tab portion 1032 of distal drive

beam segment 1030. The distal end 1034 of the distal drive beam segment 1030 may be pivotally attached to an upper non-staple forming manipulation jaw 1050 by a first pivot link 1052 and also attached to a lower non-staple-forming manipulation jaw 1060 by a second pivot link 1062. As used herein, the term “non-staple forming” refers to jaws that are designed to grip or manipulate tissue, but are not designed to form, support or drive staples, such as, for example, anvils, staple cartridges or portions of units designed to support staple cartridges.

[0070] FIGS. 2 and 3 illustrate the upper and lower manipulation jaws 1050, 1060 in an open orientation and FIG. 4 illustrates the upper and lower manipulation jaws 1050, 1060 in a closed orientation. Once the surgical tool 1000 is coupled to the elongated body 14 of the surgical apparatus 10 (and the distal end 276 of the control rod 52 is coupled to the drive member 2026), the clinician may move the upper and lower manipulation jaws 1050, 1060 between the open and closed positions by manipulating the movable handle portion 24 of the surgical apparatus 10. For example, pivoting the movable handle portion 24 toward the stationary portion 22 of the handle assembly 12, causes the control rod 52 to move the proximal drive beam segment 1022 in a “first” distal direction “DD”. As the proximal drive beam segment 1022 moves in the first distal direction “DD”, the reversing linkage 1040 pulls the distal drive beam segment 1030 in a “second” proximal direction “PD” which causes the links 1052, 1062 to each simultaneously move the upper and lower non-staple forming manipulation jaws 1050, 1060 toward each other to a closed orientation. Moving the movable handle 24 away from the stationary handle portion 22 causes the non-staple forming upper and lower manipulation jaws 1050, 1060 to each simultaneously move away from each other to the open position.

[0071] The person of ordinary skill in the art will understand that the non-staple forming upper and lower manipulation jaws 1050, 1060 may be provided in different shapes and sizes without departing from the spirit and scope of the present invention. For example, FIG. 5 illustrates one use of the surgical tool 1000 of the present invention in connection with the removal of tissue, etc. from a body cavity 600. More specifically, FIG. 5 illustrates use of a conventional first trocar 610 that is used to form a first passage 604 through a body wall 602 into the body cavity 600. A surgical tool 1000 of the present invention is attached to a first conventional surgical apparatus 10. The surgical tool 1000 is then inserted through a cannula in the first trocar 610 and into the body cavity 600 to grasp and manipulate a portion of tissue 606.

[0072] Some medical procedures may require portions of diseased tissue or organs to be removed from the body cavity 600. To facilitate removal of small amounts of such tissue from the body cavity 600, another surgical tool 1100 of the present invention may be employed. As can be seen in FIG. 5, the surgical tool 1100 may include a housing portion 1110 that has a proximal end 1112 that has nubs 254 formed thereon to facilitate attachment to the elongated body portion 14 of a surgical apparatus 10' in the manner described above. Housing 1110 may have a hollow cavity therein, that would facilitate the movement of the control rod 52 therein. However, in various embodiments, the distal end 276 of the control rod is not directly coupled to any component within the housing. Attached to the distal end 1114 of the housing 1110 is a specimen-retrieval pouch 1120 that may be formed from a collapsible pouch ring portion 1122 that has a flexible

pouch member 1124 attached thereto. The collapsible pouch ring 1122 may be fabricated from spring arms 1226 or the like that would enable the pouch ring portion 1122 to collapse to enable the specimen retrieval pouch 1120 to be inserted into and retracted from a cannula of a conventional trocar 610 or the like.

[0073] Returning to FIG. 5, there is also illustrated a surgical tool 1100 of the present invention that has been attached to another conventional surgical instrument 10' that has been inserted through another conventional trocar 610. After the pouch assembly 1120 has been passed through the trocar cannula into the body cavity 600, the collapsible pouch ring 1122 springs open. The surgical tool 1000 may be employed to grasp diseased tissue 606 (e.g., gall stones, etc.) and place the diseased tissue 606 into the pouch assembly 1120 which may then be retracted out through the cannula of the second conventional trocar 610. A draw string 1121 extends around the pouch ring 1112 and through the housing 1110 to be threaded through a portion of the elongated body 14 and may exit through a hole therein adjacent the handle assembly 12. The draw string 1121 may be used to close the specimen retrieval pouch 1120 when removing the filled pouch 1120 from the body cavity.

[0074] Certain other medical procedures involve the cutting and removal of small portions of tissue such as the removal of a polyp 700 or the extraction of a small portion of tissue for testing. A surgical tool embodiment 1200 of the present invention may be used to perform such activities. More specifically and with reference to FIG. 6, a surgical tool 1200 may include the housing portion 1110 and drive beam segments 1022, 1030 as was described above. The surgical tool 1200 is coupled to the elongated body portion 14 and the control rod 52 in the manner described above and is operated by moving the movable handle portion 24 toward and away from the stationary handle portion 22 as was also described above. However, in various embodiments, instead of having upper and lower manipulation jaws coupled thereto, an upper tissue nipping jaw 1210 and a lower tissue nipping jaw 1220 are attached to links 1052 and 1062, respectively. As can be seen in FIG. 6, the upper and lower tissue nipping jaws 1210 and 1220 are designed to nip tissue grasped therebetween. At least one of the jaws 1210, 1220 have a cavity portion 1211 therein for retrieving the nipped tissue. In the embodiment depicted in FIG. 6, each tissue nipping jaw 1210, 1220 have a cavity portion 1211 formed therein that cooperate to form a hollow receptacle area generally designated as 1230 when the jaws 1210, 1220 are substantially closed. Thus, after the tissue 700 has been nipped by closing the jaws 1210, 1220, the tissue 700 is then received in the hollow receptacle area 1230 for removal from the body.

[0075] FIG. 7 illustrates another surgical tool 1300 of the present invention that includes the housing portion 1110 and drive assembly 1020 as described above. As can be seen in FIG. 7, however, the surgical tool 1300 employs scissor jaws 1310 and 1320. In particular, the upper scissor jaw 1310 is attached to link 1052 and the lower scissor jaw is attached to link 1062. A support member 1380 protrudes out of the distal end of the housing portion 1110 and pivotally supports the scissor jaws 1310, 1320 about a pivot pin 1382 as shown. The surgical tool 1300 is coupled to the elongated body portion 14 and the control rod 52 of the surgical instrument 10 in the manner described above and is operated by moving the movable handle portion 24 toward and away from the

stationary handle portion 22 as was also described above. Thus, the scissor jaws 1310, 1320 may be aligned with each other to enable the surgical tool 1300 to be inserted through a cannula (trocar) into the body cavity and then activated to cut tissue by moving the movable handle portion 24 of the surgical instrument 10.

[0076] FIGS. 8-12 illustrate another surgical tool 1400 that may be used with the conventional surgical instrument 10. As can be seen in those Figures, the surgical tool 1400 comprises a stapler for stapling tissue. More particularly and with reference to FIG. 8, the surgical tool 1400 may include a housing portion 1410 that has a proximal end portion 1412 that is configured for removable attachment to the elongated body 14 of the surgical instrument 10. In particular, the proximal end portion 1412 may have engagement nubs 254 formed thereon which serve to form a bayonet-type coupling with the distal end of the elongated body portion 14 of the surgical instrument 10 as described above. The surgical tool 1400 may include a drive assembly 1420 that includes an elongated drive beam 1422 that may be constructed from a single sheet of material or, preferably, from multiple stacked sheets. However, drive beam 1422 may be fabricated from other suitable materials and arrangements. As can be seen in FIG. 9, the drive beam 1422 has an engagement section 1424 formed thereon that may include a pair of engagement fingers 1424a and 1424b that are dimensioned and configured to mountingly engage a drive member 1426. Drive member 1426 includes a proximal porthole 1428 configured to receive the distal end 276 of control rod 52 (See FIG. 1) when the proximal end 1412 of the surgical tool 1400 is coupled to the elongated body 14 of a surgical instrument 10. As can be seen in FIG. 9, the proximal end 1412 has a hollow passage 1414 therein through which the distal end 276 of the control rod 52 may extend.

[0077] As can also be seen in FIGS. 9-12, the housing 1410 has a distal end portion 1416 that operably houses columns 1430 of surgical staples 1432 therein. In various embodiments, the housing 1410 may be fabricated in multiple segments to permit installation of the staples 1432 therein. For single use embodiments, the staples 1432 may be installed at the factory and the housing portions permanently assembled together by adhesive, snaps, etc. In other embodiments, the housing portions may be removably coupled together to permit installation of additional staples 1432. As can also be seen in FIGS. 9-12, a staple driver 1440 is affixed to the distal end of the drive beam 1422. The distal end 1442 of the staple driver 1440 may have a staple-receiving notch 1444 formed therein as can be seen in FIGS. 10-12.

[0078] The surgical tool 1400 is coupled to the elongated body portion 14 and the control rod 52 of the surgical instrument 10 in the manner described above and is operated by moving the movable handle portion 24 toward and away from the stationary handle portion 22 as was also described above. A return spring 1450 is supported between a wall portion 1418 of the housing 1410 and a return tab portion 1446 on the staple driver 1440 to assist with returning the staple driver 1440 to the return position wherein another staple 1432 may drop into a firing position as shown in FIG. 10. As can be seen in FIG. 10, when in a firing position, the bottom staple 1432 in the distal-most column 1430 of staples 1432 has dropped into engagement with the staple-receiving notch 1444 in the staple driver 1440. A leaf-type feed spring 1470 may be provided to bias each succeeding staple 1432

in the distal-most column 1430 of staples downward toward the staple driver 1440. In addition, a spring assembly 1480 (illustrated in box-form in FIGS. 10-12) is mounted in the distal end portion 1416 of the housing 1410 to bias the columns 1430 of staples 1432 in the distal direction "DD" on the staple driver 1440 so that as one column of staples 1432 is depleted, the next adjacent column of staples 1432 is biased into the firing position shown in FIG. 10.

[0079] Thus, to use the surgical tool 1400, the distal end 1416 of the housing portion 1410 is brought into engagement with the tissue "T" to be stapled. See FIG. 11. As can be seen in FIGS. 10-12, the distal end portion 1416 has an angled end 1417 that has an opening 1419 therein to expose the staple 1432 being fired. As the staple 1432 is fired (i.e., driven in the distal direction "DD" by the staple driver 1440) through movement of the movable handle portion 24 of the surgical instrument 10, it is formed as it contacts a staple-forming anvil 1490 non-movably mounted within the housing 1410. FIG. 10 illustrates the surgical tool 1400 prior to firing. FIG. 11 illustrates firing a staple 1432 into the tissue "T". FIG. 12 illustrates the staple driver 1440 after is has been retracted to permit another staple 1432 to drop into a ready position. While the surgical tool 1400 is particularly well-suited for endoscopic procedures, those of ordinary skill in the art will also appreciate that the surgical tool 1400 may also be used to staple open incisions that do not require the surgical tool 1400 to be inserted through a cannula into a body cavity.

[0080] FIGS. 13 and 14 illustrate another surgical tool 1500 that may be used with the conventional surgical instrument 10. As can be seen in those Figures, the surgical tool 1500 comprises a syringe for deploying, for example, glue, sealant, a drug or other medicament. More particularly and with reference to FIG. 14, the surgical tool 1500 may include a housing portion 1500 that has a proximal end portion 1512 that is configured for removable attachment to the elongated body 14 of the surgical instrument 10. In particular, the proximal end portion 1512 may have engagement nubs 254 formed thereon which serve to form a bayonet-type coupling with the distal end of the elongated body portion 14 of the surgical instrument 10 as described above. The surgical tool 1500 may include a drive assembly 1520 that comprises an elongated drive beam 1522 that may be constructed from a single sheet of material or, preferably, from multiple stacked sheets. However, drive beam 1522 may be fabricated from other suitable materials and arrangements. As can be seen in FIG. 14, the drive beam 1522 has an engagement section 1524 formed thereon that may include a pair of engagement fingers 1524a and 1524b that are dimensioned and configured to mountingly engage a drive member 1526. Drive member 1526 includes a proximal porthole 1528 configured to receive the distal end 276 of control rod 52 (See FIG. 1) when the proximal end 1512 of the surgical tool 1500 is coupled to the elongated body 14 of surgical instrument 10. As can be seen in FIG. 14, the proximal end 1512 has a hollow passage 1514 therein through which the distal end 276 of the control rod 52 may extend.

[0081] As can also be seen in FIGS. 13 and 14, a syringe body 1570 is attached to a distal end 1516 by a collar 1572 or other fastener arrangement. The collar 1572 may be affixed to the housing 1510 and syringe body 1570, by adhesive or other suitable arrangements. As can be seen in FIG. 14, a distal end 1523 of the drive beam 1522 is attached

to a syringe plunger 1574 that is movably supported within the syringe body 1570. A hollow needle or cannula 1580 may be attached to the distal end of the syringe body 1570 as shown. The syringe body 1570 may be filled with a drug or medicament by first advancing the syringe plunger 1574 to the distal end of the syringe body 1570 by moving the movable handle 24 of the surgical instrument 10 (FIG. 1) toward the stationary handle portion 22 of the handle assembly 12. Thereafter, the pointed end 1582 of the needle 1580 may be inserted into a vial or reservoir of glue, sealant, drug or medicament (not shown). The clinician may then draw the material from the reservoir into the syringe body 1570 through the needle 1580 by moving the movable handle 24 away from the stationary portion 22 of the handle assembly 12 which serves to move the drive beam 1522 and the syringe plunger 1574 in the proximal direction "PD". Once the desired amount of drug or medicament has been drawn into the syringe body 1574, the clinician may then insert the surgical tool 1500 into the body cavity through a cannula or other opening and then expel the drug or medicament from the syringe body 1570 by again moving the movable handle 24 toward the stationary handle portion 22 of the handle assembly 12. A scale or other form of measuring indicia 1590 may be provided on the syringe body 1570 to enable the clinician to monitor the amount of glue, sealant, drug or medicament that has been discharged from the syringe body 1574.

[0082] When a surgical procedure involves stapling of tissue, the clinician must select the proper size of staple to use based upon the thickness of the tissue to be stapled. For example, staples that are commonly used for endoscopic procedures are generally manufactured in various sizes to provide various formed heights such as 0.75 mm, 1.0 mm, 1.5 mm, 2.0 mm, etc. The clinician must carefully match the size of the staple to the thickness of the tissue. If the staple is too large, the tissue may not be held together properly or if the staple is too small, it may tear through the tissue. In the past, however, the clinician often would have to estimate the tissue thickness and then hope that the estimate was sufficiently accurate. Thus, there is a need for a surgical tool that could be used in connection with a surgical instrument 10 that can accurately measure tissue thickness so that the appropriate size of staples may be used.

[0083] FIGS. 15-30 depict a surgical tool embodiment 1600 of the present invention that may be operably coupled to the surgical instrument 10 and used to measure the thickness of tissue "T" that may need to be cut and stapled. As can be seen in those Figures, the surgical tool 1600 may include a carrier 216 that has a housing 1610 attached thereto. The housing 1610 may be attached to the upstanding walls 217 of the carrier 216 by snap features 219 or other suitable means. The housing 1610 has a proximal end 1612 that is configured for removable attachment to the elongated body 14 of the surgical instrument 10. In particular, the proximal end 1612 may have engagement nubs 254 formed thereon which serve to form a bayonet-type coupling with the distal end of the elongated body portion 14 of the surgical instrument 10 as was described above.

[0084] The surgical tool 1600 further includes a drive assembly 1620 that includes a drive beam 1622 that may be constructed from a single sheet of material or, preferably, from multiple stacked sheets. However, drive beam 1622 may be fabricated from other suitable materials and arrangements. As can be seen in FIG. 16, the drive beam segment

1622 has an engagement section 1624 formed thereon that may include a pair of engagement fingers 1624a and 1624b that are dimensioned and configured to mountably engage a drive member 1626. Drive member 1626 includes a proximal porthole (not shown) to receive the distal end 276 of control rod 52 (See FIG. 1) when the proximal end 1612 of surgical tool 1600 is coupled to the elongated body 14 of the surgical instrument 10.

[0085] The distal end 1626 of the drive beam 1622 may have a camming pin or roller 286 (FIG. 16) arranged to engage a camming portion 209 (FIG. 18) of a non-staple forming anvil assembly 20 that is pivotally coupled to the carrier 216. A pair of pivot members 211 are formed on the anvil assembly 20 and are positioned within slots 213 formed in carrier 216 to guide the anvil portion between the open and clamped positions. As the drive beam 1622 is driven in the distal direction "DD" by moving the movable handle 24 toward the stationary handle portion 22 of the handle assembly 12 of the surgical instrument 10, the camming roller on the distal end of the drive beam 1622 engages the camming portion 209 of the anvil assembly 20 and causes the anvil assembly 20 to pivot to a given and repeatable closed position which forms a reference surface for establishing a thickness measurement.

[0086] The surgical tool 1600 may further include a tissue thickness measuring cartridge 1650 that is supported within the carrier 216. As can be seen in FIGS. 18-22, the thickness measuring cartridge 1650 includes a body portion 1652 that is mounted within the carrier 216 and retained therein by snap features 1654 (FIG. 22) or other appropriate fastener arrangements. As can be seen in FIG. 22, for example, the cartridge body 1652 may be fabricated from two body segments 1652a, 1652b that may be fastened together by adhesive or other appropriate fasteners. As can be further seen in FIG. 22, the cartridge body 1652 operably supports a movable tissue measuring platform 1660. Tissue platform 1660 may be configured as shown in FIGS. 22 and 23 and have a proximal end portion 1662 that is coupled to the cartridge body portion 1652 by a hinge pin 1664. A platform spring 1666 may be journaled on the hinge pin 1664 to bias the tissue platform 1660 in a direction toward the anvil assembly 20 (represented by arrow "U" in FIGS. 17 and 19). The hinge pin 1664 may be mounted within corresponding holes 1653 in the body segments 1652a, 1652b. See FIG. 22. As can also be seen in FIGS. 23 and 26-30, the distal end 1668 of the tissue plate 1660 has a downwardly protruding gear rack segment 1669 thereon that is adapted to drivingly interface with a gear assembly 1670.

[0087] As can be seen in FIGS. 22 and 23, gear assembly 1670 may include a first rack gear 1672 that is keyed onto a first gear shaft 1680 that is rotatably supported in holes 1682 in the body segments 1652a, 1652. A second step gear 1674 may also be keyed onto the first gear shaft 1680. The gear assembly 1670 may further include a third transfer gear 1676 that is keyed onto a second gear shaft 1690 that is rotatably supported in holes 1692 in the body segments 1652a, 1652b and in meshing engagement with the second step gear 1674. A fourth output gear 1678 is also keyed onto the second gear shaft 1690 and is in meshing engagement with a gear rack portion 1702 of an indicator member or base 1700 that is slidably supported in the carrier 216. Thus, as can be appreciated from reference to FIG. 27, as the tissue platform 1660 is depressed downward (arrow "DW"), the gear rack segment 1669 protruding therefrom causes the first

rack gear 1672 to rotate counterclockwise “CCW” in FIG. 27 which also causes the second step gear 1674 to also rotate in the counterclockwise direction. The second step gear 1674 is in meshing engagement with the third transfer gear 1676 and is caused to rotate in the clockwise “CW” direction in FIG. 27. As the third transfer gear 1676 rotates clockwise, so does the output gear 1678. As the output gear 1678 rotates clockwise (“CW”), it drives the indicator base 1700 in the distal direction “DD” by virtue of its meshing engagement with the indicator rack 1702. In various embodiments, for example, a gear ratio of approximately 30 to 1 may be employed such that 60 mm of linear firing motion is accomplished in approximately 3 seconds. However, other gear ratios could conceivably be employed.

[0088] As can be most particularly seen in FIG. 23, the indicator base 1700 may be bifurcated into two lateral indicator leg portions 1710 that each terminate in an upstanding indicator plate 1712. Each indicator plate 1712 may have a series of thickness identifiers or indicators thereon. In particular, each indicator plate 1712, may have a first thickness identifier 1720 that corresponds to a first tissue thickness range “T1”. For example, the first tissue thickness range “T1” may represent tissue having a thickness of about 75 mm to about 1.0 mm which would require a formed staple size of 0.75 mm. Each indicator plate 1712 may further have a second thickness identifier 1722 that corresponds to a second tissue thickness range “T2”. For example, the second tissue thickness range “T2” may be for tissue having a thickness of about 1.0 mm to about 1.5 mm which would require a formed staple size of, for example, 1.0 mm. Each indicator plate 1712 may further have a third tissue thickness identifier 1724 that corresponds to a third tissue thickness range “T3” that corresponds to a third particular size of tissue. For example, the third thickness range “T3” may be for tissue having a thickness of about 1.5 mm to 2.0 mm which would require a formed staple size of, for example, 1.5 mm. Each indicator plate 1712 may further have a fourth tissue thickness identifier 1726 that corresponds to a fourth tissue thickness range “T4” that corresponds to a fourth particular size of tissue. For example, the fourth tissue thickness range “T4” may be for tissue having a thickness of about 2.0 mm which would require a formed staple size of, for example, 2.0 mm. The tissue identifiers 1720, 1722, 1724, 1726 may comprise, for example, numbers, letters, colors, etc. that are each understood to correspond to a particular tissue thickness range. In various embodiments, a proximal tissue stop 1721 may be provided on the cartridge 1652 to provide an abutment wall to position the tissue between the cartridge 1652 and the anvil assembly 20. See FIGS. 17, 22, and 24. Also in various embodiments, tissue grip members 1723 may be provided on the cartridge 1652 as shown in FIG. 22 to assist with the gripping and positioning of tissue between the cartridge 1652 and the anvil assembly 20.

[0089] As can be seen in FIG. 25, a view window 1730 may be provided in each lateral side portion of the housing 1610 to coincide with the tissue identifiers 1720, 1722, 1724, 1726 as will be discussed in further detail below. FIGS. 18 and 19 illustrate the positions of the indicator plates 1712 when no tissue has been clamped between the anvil assembly 20 and the tissue platform 1660. As can be seen in those Figures, none of the thickness indicators 1720, 1722, 1724, 1726 can be observed through the viewing windows 1730. FIGS. 26 and 27 illustrate the positions of the indicator

plates 1712 when tissue having a tissue thickness range T1 is clamped between the anvil assembly 20 and the tissue platform 1660. As can be seen in those Figures, the first tissue indicator 1720 is viewable through the corresponding window 1730.

[0090] FIG. 28 illustrates the positions of the indicator plates 1712 when tissue having a tissue thickness range T2 is clamped between the anvil assembly 20 and the tissue platform 1660. As can be seen in that Figure, the second tissue indicator 1722 is viewable through the corresponding window 1730. FIG. 29 illustrates the positions of the indicator plates 1712 when tissue having a tissue thickness range T3 is clamped between the anvil assembly 20 and the tissue platform 1660. As can be seen in that Figure, the third tissue indicator 1724 is viewable through the corresponding window 1730. FIG. 30 illustrates the positions of the indicator plates 1712 when tissue having a tissue thickness range T4 is clamped between the anvil assembly 20 and the tissue platform 1660. As can be seen in that Figure, the fourth tissue indicator 1726 is viewable through the corresponding window 1730. Thus, by operably attaching the surgical tool 1600 to the surgical instrument 10 and clamping a portion of target tissue to be stapled between the tissue platform 1660 and anvil assembly 20 (by activating the movable handle portion 24 toward the stationary handle portion 22), the clinician can ascertain the approximate thickness of the tissue to be stapled and then select a disposable stapling unit of for example, the type disclosed in U.S. Pat. No. 5,865,361 with the appropriate sized staples. The clinician then simply detaches the surgical tool 1600 from the surgical instrument 10 and then operably attaches the selected disposable stapling unit to the surgical instrument 10 and operates it as described in U.S. Pat. No. 5,865,361.

[0091] FIGS. 31-35 illustrate another surgical tool embodiment 1800 that comprises a clip applier for use with a surgical instrument 10 to apply at least one surgical clip 1801 to a human body. Various embodiments of the surgical tool 1800 may employ various components of the clip appliers disclosed in U.S. Pat. No. 5,951,574, entitled MULTIPLE CLIP APPLIER HAVING A SPLIT FEEDING MECHANISM, issued Sep. 14, 1999, the disclosure of which is herein incorporated by reference. The use of surgical clips 1801 to ligate structures within the body such as vessels, ducts, and tissue is well known in the surgical art. Various embodiments of the surgical tool 1800 may have a distal pair of opposed moveable jaws 1820 for receiving clips 1801 serially therein when the jaws 1820 are open and forming the clip 1801 received serially therein when the jaws 1820 are closed. See FIG. 33. The jaws 1820 may be connected to a distal end of a generally rectangular shaft 1830 that protrudes from a housing assembly 1840. The shaft 1830 may have a structural “U” shaped outer wrap 1832, a transparent upper shroud 1834, and a clip magazine containing a plurality of clips (not shown) located therein.

[0092] The housing assembly 1840 may include a base portion 1842 that has a cover 1844 attached thereto. See FIG. 34. The base portion 1842 has a proximal end 1846 that is configured for operable attachment to the elongated body 14 and the control rod 52 of the surgical instrument 10. The proximal end portion 1846 has a hollow connector portion 1848 that includes engagement nubs 254 for releasably engaging elongated body 14 of the surgical instrument 10.

[0093] The instrument 1800 may further include a firing rod connector 1850 that has a porthole 1852 therein for

receiving the distal end 276 of the control rod 52. See FIG. 34. The firing rod connector 1850 is coupled to a forming plate 1860 that may be otherwise similar in construction to the forming mechanism 85 disclosed in U.S. Pat. No. 5,951,574, except for the differences discussed herein. As can be seen in FIGS. 31-33 and 35, the forming plate 1860 may have a forming rack 1862 thereon for meshing engagement with a gear assembly 1870. The gear assembly 1870 may be rotatably supported on a gear post 1872 that protrudes from the base portion 1842 and extends through an elongated slot 1864 in the forming plate 1860. The gear assembly 1870 may have a forming gear portion 1874 that is in meshing engagement with the forming rack 1862. The gear assembly 1870 may also comprise a feed gear 1876 that is attached to the forming gear 1874. The feed gear 1876 is in meshing engagement with a feed rack 1882 formed on a feed plate 1880 which performs the same functions as the feed mechanism 100 of U.S. Pat. No. 5,951,574. In various embodiments, the gear assembly 1870 and gear racks 1862, 1882 may have a 2:1 gear ratio, such that as the forming plate 1860 is driven in a distal direction "DD", the feed plate 1880 is simultaneously driven in the proximal direction "PD" only half as far as the forming plate 1860 was driven in the distal direction "DD".

[0094] The surgical tool 1800 also has a clip pusher 1890 (FIG. 33) that remains generally stationary throughout most of the simultaneous motion. The clip pusher 1890 is releasably coupled to the moving feed plate 1880 as the control rod 52 moves the feed plate 1880 in a proximal direction for the placement of a clip 1801 into the opening jaws 1820. The clip magazine within the shaft 1830 supplies additional clips 1801 to the feed plate 1880 and clip pusher 1890 for serial placement of the clips 1801 into the jaws 1802.

[0095] The surgical tool 1800 is activated by moving the control rod 52 in the distal direction "DD" which causes the closure of the jaws 1820 and the formation of each of the clips 1801 received serially therein. Moving the control rod 52 in the proximal direction "PD" opens the jaws 1820, releases the fully formed clip 1801, and feeds an unformed clip 1801 serially into the open jaws 1820. The surgical tool 1800 is coupled to the elongated body portion 14 and the control rod 52 in the manner described above and is operated by moving the movable handle portion 24 toward and away from the stationary handle portion 22 as was also described above. The person of ordinary skill in the art will understand that the surgical tool 1800 is especially adapted for use in open surgical applications thereby expanding the use of the conventional surgical instrument 10 which, in the past, has been limited to use in connection with endoscopic surgical procedures.

[0096] The tool assemblies of the prior disposable loading units that have been designed for use with the conventional surgical instrument 10 are configured to deploy staples in straight lines. During many surgical techniques, such as the resection of stomach tissue, for example, such a linear deployment is often preferred. During these techniques, the disposable loading unit is typically inserted through a cannula to access the surgical site and, as a result, it is often desirable for the tool assembly thereof to have a linear configuration that can be aligned with an axis of the cannula before the tool assembly is inserted therethrough. However, in some circumstances, those tool assemblies that have such a linear configuration are somewhat difficult to use. More particularly, for example, when the tool assembly must be

placed adjacent to or against a cavity wall, such as the thoracic cavity wall, for example, it is often difficult for the surgeon to position a jaw of the tool assembly behind delicate or fragile tissue which is proximal to and/or attached to the cavity wall. Furthermore, even if the surgeon is successful in positioning a jaw behind the tissue, owing to the linear configuration of the tool assembly, the surgeon may not be able to see the distal end of the tool assembly. In some circumstances, surgical instruments that have a reusable blade and drive system have been developed to employ curved end effectors. Examples of such devices are disclosed in commonly-owned U.S. patent application Ser. No. 11/652,170, filed Jan. 11, 2007 and entitled SURGICAL STAPLER END EFFECTOR WITH A TAPERED DISTAL END, now U.S. Patent Application Publication No. 2008/0169333, the disclosure of which has been herein incorporated by reference.

[0097] FIG. 36 depicts another surgical tool embodiment 1900 of the present invention that may be used in connection with a surgical instrument 10. As can be seen in that Figure, the surgical tool 1900 may include a curved carrier 1916 that has a housing member 1910 attached thereto. The housing 1910 may be attached to the upstanding walls 1917 of the carrier portion by snap features or other suitable means. The housing member 1610 has a proximal end 1912 that is configured for removable attachment to the elongated body 14 of the surgical instrument 10. In particular, the proximal end 1912 may have engagement nubs 254 formed thereon which serve to form a bayonet-type coupling with the distal end of the elongated body portion 14 of the surgical instrument 10 as was described above.

[0098] In various embodiments of the present invention, the carrier 1916 and the staple cartridge 1920 supported therein are curved. In various embodiments, for example, the curvature of those components can be configured to substantially match the contour of a typical thoracic cavity wall. In these embodiments, the curvature of several thoracic cavity walls can be measured and statistically analyzed to determine the optimum profile of the curved end-effector. This profile can include several arcuate portions and, in addition, several linear portions. In other embodiments, the curvature of the thoracic cavity wall can be approximated by a single radius of curvature. Such embodiments can be simpler and less expensive to manufacture. In at least one embodiment, this radius of curvature is 1.2". In other various embodiments, the curvature of the carrier 1916 and staple cartridge 1920 can be configured to match the profile of the lower rectum, pelvis, or lower abdomen. FIG. 37 illustrates, for example, an alternative surgical instrument 1900' that employs a carrier 1916' that has a curvature that differs from the curvature of carrier 1916. Other curvatures disclosed in the aforementioned U.S. patent application Ser. No. 11/652,170, now U.S. Patent Application Publication No. 2008/0169333, may also be employed.

[0099] In various embodiments of the present invention, the staple cartridge 1920 includes a curved slot 1922 for controlling the movement of axial drive assembly 1966 along a curved path. This curved slot 1922 can include several arcuate portions and several linear portions. In various embodiments, the curved slot 1922 can be defined by one radius of curvature. The anvil assembly 1930 which may otherwise be similar to the anvil assemblies described above, may have a curved portion (omitted for clarity in FIGS. 36 and 37) that substantially matches the curvature of

the carrier 1916 and the staple cartridge 1920. In the embodiments illustrated in FIGS. 36 and 37, the staple cartridge 1920 has a curved slot 1922. The carrier 1916 and the anvil assembly may each have an identical slot (not shown) therein that, in connection with the slot 1922 are configured to receive a corresponding portion of a drive beam 1966 therein. The proximal end of the drive member 1966 may be configured in the above described manner with respect to drive beam 1622 to facilitate its driving activation by movement of the control rod 52 as described above. The distal end of the drive beam 1966 containing the blade (not shown) may be configured such that, as the drive beam 1966 is driven in the distal direction “DD” by movement of the movable handle 24 of the surgical instrument 10, the drive beam 1966 tracks the curved path defined by the slot 1922.

[0100] FIGS. 38 and 39 depict a surgical tool embodiment 2000 of the present invention that may be coupled to the surgical instrument 10 and used to cauterize tissue in an open surgical setting. As can be seen in those Figures, the surgical tool 2000 may include a housing 2010 that has a proximal end 2011 that is configured for removable attachment to the elongated body 14 of the surgical instrument 10. In particular, the proximal end 2011 may have engagement nubs 254 formed thereon which serve to form a bayonet-type coupling with the distal end of the elongated body portion 14 of the surgical instrument 10 as was described above.

[0101] The housing 2010 may further include a switch portion 2013 that movably houses a battery 2030 therein. The movable battery 2030 may be of the type and construction disclosed in commonly-owned U.S. patent application Ser. No. 12/031,628, filed Feb. 14, 2008, entitled DISPOSABLE MOTOR DRIVEN LOADING UNIT FOR USE WITH A SURGICAL CUTTING AND STAPLING APPARATUS, now U.S. Pat. No. 7,793,812, which is herein incorporated by reference. More specifically and with reference to FIG. 39, the switch portion 2013 of the housing 2010 defines a battery cavity 2032 that movably supports a battery holder 2034 that houses the battery 2030 therein. As can be seen in FIG. 39, a first battery contact 2036 is supported in electrical contact with the battery 2030 and protrudes out through the battery holder 2034 for sliding engagement with the inside wall 2033 of the battery cavity 2032. Similarly, a second battery contact 2038 is mounted in electrical contact with the battery 2030 and also protrudes out of the battery holder 2034 to slide along the inside wall 2033 of the battery cavity 2032. The battery holder 2034 has a control rod socket 2035 therein configured to receive the distal end 276 of control rod 52 when the proximal end 2011 of the surgical tool 2000 is coupled to the elongated body 14 of surgical stapling apparatus 10. As can also be seen in FIG. 39, a pair of contacts 2026, 2028 may be oriented within the wall 2033 for contact with the battery contacts 2036, 2038, respectively. The purpose of the contacts 2026, 2028 will be discussed in further detail below. As can also be seen in FIG. 39, a biasing member or switch spring 2040 is positioned within the battery cavity 2032 to bias the battery holder 2034 in the proximal direction “PD” such that when the surgical tool 2000 is not attached to the elongated body 14, the battery holder 2034 is biased to its proximal-most position shown in FIG. 39. When retained in that “pre-use” or “disconnected” position by spring 2040, the battery contacts 2036 and 2038 do not contact their respective contacts 2026,

2028 within the battery cavity 2032 to prevent the battery 2030 from being drained during non-use.

[0102] As can be seen in FIG. 38, the surgical tool 2000 may further include a non-staple applying end effector in the form of a ball-shaped end member 2050 that may be pivotally pinned to a yoke 2052 that is coupled to the distal end of the housing 2010. In various embodiments, the end effector 2050 may be fabricated from a conductive material such as stainless steel, titanium, etc. and have at least one electrically powered member 2060 therein. In the embodiment depicted in FIG. 38, the electrically powered member 2060 may comprise a heating element. Those of ordinary skill in the art will appreciate that the end-effector 2050 may be provided in a myriad of other shapes and configurations without departing from the spirit and scope of the present invention. As can be further seen in FIG. 38, the heating element 2060 may be electrically coupled to contacts 2026, 2028 by leads 2022, 2024, respectively.

[0103] Thus, when the surgical tool 2000 is unattached to the elongated body 14 of the surgical instrument 10, the battery 2030 will be biased into an unactuated position (FIG. 39) and therefore not be drained. In addition, attachment of the surgical tool 2000 to the elongated body 14 (and attachment of the control rod 52 to the battery holder socket 2035 will not result in the operation or draining of the battery 2030. To use the tool 2000, the clinician simply moves the movable handle 24 toward the stationary portion 22 of the handle assembly (FIG. 1) to drive the battery contacts 2036, 2038 into contact with contacts 2026, 2028, respectively which then powers the heating element 2060 in the end effector 2050. A light or other indicator 2070 may be supported by the housing 2010 and powered by the battery 2030 to provide the clinician with an indication that the heating element 2060 is being powered.

[0104] FIG. 40 illustrates another surgical tool embodiment 2000' that is substantially similar to the surgical tool 2000 described above. However, in this embodiment, the surgical tool 2000' does not have a battery therein. The surgical tool 2000' is constructed for use with a surgical instrument 10' that has a battery 2030' that is operated by a switch 2090 that is mounted in the handle assembly 12'. The switch 2090 communicates with a contact assembly 2092 that is located in the distal end of the elongated body 14. The contact assembly 2092 is oriented to contact a contact 2094 mounted on the proximal end of the housing portion of tool 2000' when the tool 2000' is coupled to the elongated body 14. To activate the heating element 2060 in the end effector 2050, the clinician activates the button 2090 on the handle assembly 12'. A light 2070' may also be mounted on the handle assembly 12' to provide an indication of when the tool 2000' is being powered.

[0105] FIGS. 41 and 42 illustrate alternative housing embodiments 2200 and 2200' that may be used in place of the various housing arrangements described above when flexible drive assemblies are employed. In particular, these housings 2200, 2200' may at least be employed in connection with the various embodiments depicted in FIGS. 2-30 and 36-40 when drive assemblies that are capable of flexing or at least have portions that are capable of flexing are employed. The housing 2200 depicted in FIG. 41 may be configured as shown with a proximal end portion 2202 that is configured to receive the distal end of the control rod 52 therein and that has nubs 254 thereon to facilitate attachment to the elongated body 14 as was described above. In this

embodiment, however, housing **2200** has a passive articulation joint member **2300** formed therein that facilitates passive articulation about the longitudinal axis L-L of the housing **2200** as shown. The passive articulation joint member **2300** may comprise a flexible conduit section **2302** that has interlocking ribs **2304** that are constructed to retain the passively articulated joint **2300** in an articulated orientation.

[0106] FIG. 42 illustrates another articulatable housing **2200'** that has another passive articulation joint member **2300'** that is coupled to a proximal housing portion **2400** by, for example, a proximal body collar **2310**. The flexible articulation member **2300'** has a body portion **2301** and include a plurality of kerfs **2302** separated by ribs **2304**. In various embodiments, the kerfs **2303** and ribs **2304** may be equally spaced along the flexible articulation member **2300'** thereby promoting a continuous bend radius when the flexible articulation member is articulated. A flexible articulation member **2300'** having multiple bend radii may be achieved by providing unequal spacing between the kerfs **2303** and the ribs **2304**. For example, such arrangement may be achieved by spacing the ribs **2304** more closely at one end and farther apart at the other end. As will be appreciated by those of ordinary skill in the art, increasing the spacing of the kerfs **2303** and/or the ribs **2304** reduces the bend radius of the section having increased spacing, more closely approximating a pivot point bend connection. Conversely spacing the kerfs **2303** and/or ribs **2304** more closely results in a more gradual bend, having a larger bend radius.

[0107] In the embodiment illustrated in FIG. 42, the kerfs **2302** comprise annular grooves that extend at least partially around the perimeter of the flexible articulation member **2300'**. The kerfs **2302** preferably, however, comprise semi-annular grooves which are separated by a central longitudinal spine **2306** passing down the longitudinal axis L-L of the flexible articulation member **2300'** such that a first plurality of ribs are formed on one lateral side of the spine **2306** and a second plurality of ribs **2304** are formed on another lateral side of the spine **2306**. This spine **2306** assists in providing stiffening to the flexible articulation member **2300'** and accommodates a slot (not shown) for receiving a drive assembly therethrough. The longitudinal spine **2306** may run the entire longitudinal length of the flexible articulation member **2300'**. The flexible articulation member **2300'** may also include a pair of side slot (not shown) passing through each rib **2304** on each lateral side for receiving a corresponding articulation plate (not shown) as discussed in commonly-owned U.S. patent application Ser. No. 12/031,001, entitled ARTICULATABLE LOADING UNITS FOR SURGICAL STAPLING AND CUTTING INSTRUMENT, filed on Feb. 14, 2008, now U.S. Patent Application Publication No. 2009/0206133, the disclosure of which is herein incorporated by reference. As discussed therein, such articulation plates may be fabricated from a material that is relatively inelastic. That is, the plates may be fabricated from a material that retains its position after bending. Articulation plates may, for example, be fabricated from materials such as lead, copper, etc. Those of ordinary skill in the art will understand that at least a flexible or otherwise articulatable portion of a drive assembly supported within either of the housings **2300**, **2300'** is positioned to correspond with the flexible articulation member **2300**, **2300'** to facilitate articulation of the surgical tool without adversely affecting the operation of the drive assembly extending therethrough.

[0108] Thus, as will be appreciated by the foregoing, the various surgical tool embodiments of the present invention are especially suited for use with surgical instruments that were specifically designed for use in connection with disposable cutting and stapling units that have their dedicated cutting blade and are constructed to be disposed of after a single use. While such instruments may be commonly used in connection with multiple disposable cutting and stapling units, a clinician would have to have on hand several other dedicated instruments to perform other procedures during an operation. The interchangeable tool system of the present invention solves that problem. Thus, various embodiments of the present invention may comprise a surgical tool system that may include the surgical instrument **10** and at least two of the various surgical tools disclosed herein. For example, the surgical tools may comprise a manipulator **1000**, nippers **1200**, scissors **1300**, a disposable endocutter **16**, a tissue thickness measurement device **1600**, staple appliers **1400**, clip appliers **1800**, cauterization devices **2000** and specimen retrieval devices **1100**.

[0109] While several embodiments of the invention have been described, it should be apparent, however, that various modifications, alterations and adaptations to those embodiments may occur to persons skilled in the art with the attainment of some or all of the advantages of the invention. For example, according to various embodiments, a single component may be replaced by multiple components, and multiple components may be replaced by a single component, to perform a given function or functions. This application is therefore intended to cover all such modifications, alterations and adaptations without departing from the scope and spirit of the disclosed invention as defined by the appended claims.

[0110] Any patent, publication, or other disclosure material, in whole or in part, that is said to be incorporated by reference herein is incorporated herein only to the extent that the incorporated materials does not conflict with existing definitions, statements, or other disclosure material set forth in this disclosure. As such, and to the extent necessary, the disclosure as explicitly set forth herein supersedes any conflicting material incorporated herein by reference. Any material, or portion thereof, that is said to be incorporated by reference herein, but which conflicts with existing definitions, statements, or other disclosure material set forth herein will only be incorporated to the extent that no conflict arises between that incorporated material and the existing disclosure material.

[0111] The invention which is intended to be protected is not to be construed as limited to the particular embodiments disclosed. The embodiments are therefore to be regarded as illustrative rather than restrictive. Variations and changes may be made by others without departing from the spirit of the present invention. Accordingly, it is expressly intended that all such equivalents, variations and changes which fall within the spirit and scope of the present invention as defined in the claims be embraced thereby.

1. A surgical tool for use with a surgical instrument having a handle assembly that operably supports a drive system therein for generating drive motions upon actuation of a movable handle portion thereof and an elongated body operably supporting a control rod therein for transferring the drive motions, said surgical tool comprising:

- a housing removably couplable to said elongated body;
 - a drive assembly operably supported in said housing and removably couplable to said control rod; and
 - a pair of non-staple forming jaws operably coupled to said drive assembly such that upon application of a said drive motion to said drive assembly in a first direction causes said pair of non-staple forming jaws to each simultaneously move in a closing direction toward each other and upon application of another said drive motion in a second direction, said non-staple forming jaws each simultaneously move in an opening direction away from each other.
- 2-22.** (canceled)
- 23.** A surgical system, comprising:
- a surgical instrument, comprising:
 - a surgical instrument housing;
 - an elongate shaft operably interfacing with said surgical instrument housing, wherein said elongate shaft defines a longitudinal axis; and
 - a drive system configured to generate drive motions, and wherein said surgical system further comprises:
 - a first interchangeable surgical fastening device configured for use with said surgical instrument, wherein said first interchangeable surgical fastening device comprises:
 - a first housing assembly, comprising:
 - a first proximal housing portion configured to be removably coupled to said elongate shaft; and
 - a first fastener housing extending from said first proximal housing portion, wherein said first fastener housing operably supports a plurality of first surgical fasteners therein, and wherein said first interchangeable surgical fastening device further comprises:
 - a first fastener driver configured to receive said drive motions from said drive system when said first proximal housing portion is operably coupled to said elongate shaft and drive said first surgical fasteners out of said first fastener housing in a first direction that is parallel to said longitudinal axis, and wherein said surgical system further comprises:
 - a second interchangeable surgical fastening device configured for use with said surgical instrument, wherein said second interchangeable surgical fastening device comprises:
 - a second housing assembly comprising a second proximal housing portion configured to be removably coupled to said elongate shaft;
 - a surgical fastener cartridge supported adjacent said second proximal housing portion, wherein said surgical fastener cartridge operably supports a plurality of second surgical fasteners therein; and
 - a second axial drive assembly configured to receive said drive motions from said drive system when said second proximal housing portion is coupled to said elongate shaft and drive said second surgical fasteners out of said surgical fastener cartridge in a second direction that is perpendicular to said longitudinal axis.
- 24.** The surgical system of claim **23**, wherein said first surgical fasteners are supported in at least one column of said first surgical fasteners within said first fastener housing.
- 25.** The surgical system of claim **24**, wherein said first fastener driver is configured to drive said first surgical fastener one at a time out of said first fastener housing.
- 26.** The surgical system of claim **25**, wherein said first surgical fasteners are supported in at least two columns within said first fastener housing.
- 27.** The surgical system of claim **26**, wherein said first fastener driver is configured to drive a bottom-most one said first surgical fasteners in a distal-most one of said at least two columns of said first fasteners.
- 28.** The surgical system of claim **27**, wherein said distal-most one of said at least two columns of said first surgical fasteners is positioned in a firing location, and wherein when a last one of said first surgical fasteners in said distal-most one of said at least two columns of said first surgical fasteners has been driven out of said first fastener housing, an adjacent one of said at least two columns of said first surgical fasteners is biased into said firing location by a first biasing member.
- 29.** The surgical system of claim **28**, wherein said first interchangeable surgical fastening device further comprises a second biasing member to serially bias each said first surgical fastener in said distal-most column of said at least two columns of first surgical fasteners into engagement with said first fastener driver.
- 30.** The surgical system of claim **25**, wherein said second axial drive assembly is configured to drive at least two of said second surgical fasteners out of said surgical fastener cartridge simultaneously.
- 31.** The surgical system of claim **23**, wherein said second axial drive assembly comprises a tissue cutting feature.
- 32.** The surgical system of claim **23**, wherein said second interchangeable surgical fastening device comprises:
 - a carrier coupled to said second housing assembly, wherein said carrier is configured to operably support said surgical fastener cartridge therein; and
 - an anvil that is movably supported on said carrier for selective movement relative thereto between an open position and a closed position.
- 33.** The surgical system of claim **32**, wherein said second axial drive assembly is configured to apply closure motions to said anvil.
- 34.** The surgical system of claim **23**, wherein said first proximal housing portion comprises a first bayonet coupling configured for removable attachment to a distal end of said elongate shaft, and wherein said second proximal housing portion comprises a second bayonet coupling configuration configured for removable attachment to said distal end of said elongate shaft.
- 35.** A collection of surgical tools configured for interchangeable use with a surgical instrument including an elongate shaft that defines a longitudinal axis and a drive system configured to generate drive motions, and wherein said collection of surgical tools comprises:
 - a first interchangeable surgical stapling tool, comprising:
 - a first proximal housing portion configured to be removably coupled to the elongate shaft of the surgical instrument; and
 - a first stapler housing extending from said first proximal housing portion, wherein said first stapler housing operably supports a plurality of first surgical staples therein, and wherein said first interchangeable surgical stapling tool further comprises:

- a first staple driver configured to receive the drive motions from the drive system of the surgical instrument when said first proximal housing portion is operably coupled to the elongate shaft and drive said first surgical staples out of said first stapler housing in a first direction that is parallel to the longitudinal axis, and wherein said collection surgical tools further comprises:
- a disposable loading unit, comprising:
 - a disposable loading unit housing comprising a second proximal housing portion configured to be removably coupled to the elongate shaft;
 - a surgical staple cartridge supported adjacent said disposable loading unit housing, wherein said surgical staple cartridge operably supports a plurality of second surgical staples therein; and
 - a disposable loading unit axial drive assembly configured to receive the drive motions from the drive system when said second proximal housing portion is coupled to the elongate shaft and drive said second surgical staples out of said surgical fastener cartridge in a second direction that is perpendicular to the longitudinal axis.
- 36.** The collection of surgical tools of claim **35**, wherein said first surgical staples are supported in at least one column of said first surgical staples within said first stapler housing.
- 37.** The collection of surgical tools of claim **36**, wherein said first staple driver is configured to drive said first surgical staples one at a time out of said first stapler housing.
- 38.** The collection of surgical tools of claim **36**, wherein said first surgical staples are supported in at least two columns within said first stapler housing.
- 39.** The collection of surgical tools of claim **38**, wherein said first staple driver is configured to drive a bottom-most one said first surgical staples in a distal-most one of said at least two columns of said first staples.
- 40.** The collection of surgical tools of claim **39**, wherein said distal-most one of said at least two columns of said first surgical staples is positioned in a firing location, and wherein when a last one of said first surgical staples in said distal-most one of said at least two columns of said first surgical staples has been driven out of said first stapler housing, an adjacent one of said at least two columns of said first surgical staples is biased into said firing location by a first biasing member.
- 41.** The collection of surgical tools of claim **40**, wherein said first interchangeable surgical stapling device further comprises a second biasing member configured to serially bias each said first surgical staple in said distal-most column of said at least two columns of said first surgical staples into engagement with said first staple driver.
- 42.** The collection of surgical tools of claim **35**, wherein said disposable loading unit axial drive assembly is configured to drive at least two of said second surgical staples out of said surgical staple cartridge simultaneously.
- 43.** The collection of surgical tools of claim **42**, wherein said disposable loading unit axial drive assembly comprises a tissue cutting feature.

* * * * *