



US 20060088682A1

(19) **United States**

(12) **Patent Application Publication**
Dronzek

(10) **Pub. No.: US 2006/0088682 A1**

(43) **Pub. Date: Apr. 27, 2006**

(54) **DURABLE SUPPORTS FOR LABELING AND RELABELING OBJECTS**

Publication Classification

(75) Inventor: **Peter Dronzek**, Thornwood, NY (US)

(51) **Int. Cl.**
B32B 33/00 (2006.01)

Correspondence Address:
Robert S.M. Gorman, Esq./Gorman Associates
Law Offices
Suite 449
305 Madison Avenue
New York, NY 10165 (US)

(52) **U.S. Cl.** **428/40.1**

(57) **ABSTRACT**

(73) Assignees: **Polymeric Converting LLC; Sunbelt Consult. Group Inc.; Marathon Durable Labeling Inc**

Durable self-adhesive laminates for use as supports for labeling comprising:

(21) Appl. No.: **11/256,899**

(a) a fluoropolymer film having (A) a label-receiving side and (B) an adhesive side, the label-receiving side consisting of a controlled-release surface without making use of a coated release substance and adapted to support a removable label attachable thereto by means comprising attraction forces between the fluoropolymer film and a label; and

(22) Filed: **Oct. 24, 2005**

Related U.S. Application Data

(b) an adhesive having an ultimate release energy level greater than the attraction forces between the fluoropolymer film and a removable label or labels.

(63) Continuation of application No. 10/368,327, filed on Feb. 18, 2003, now Pat. No. 6,986,826.

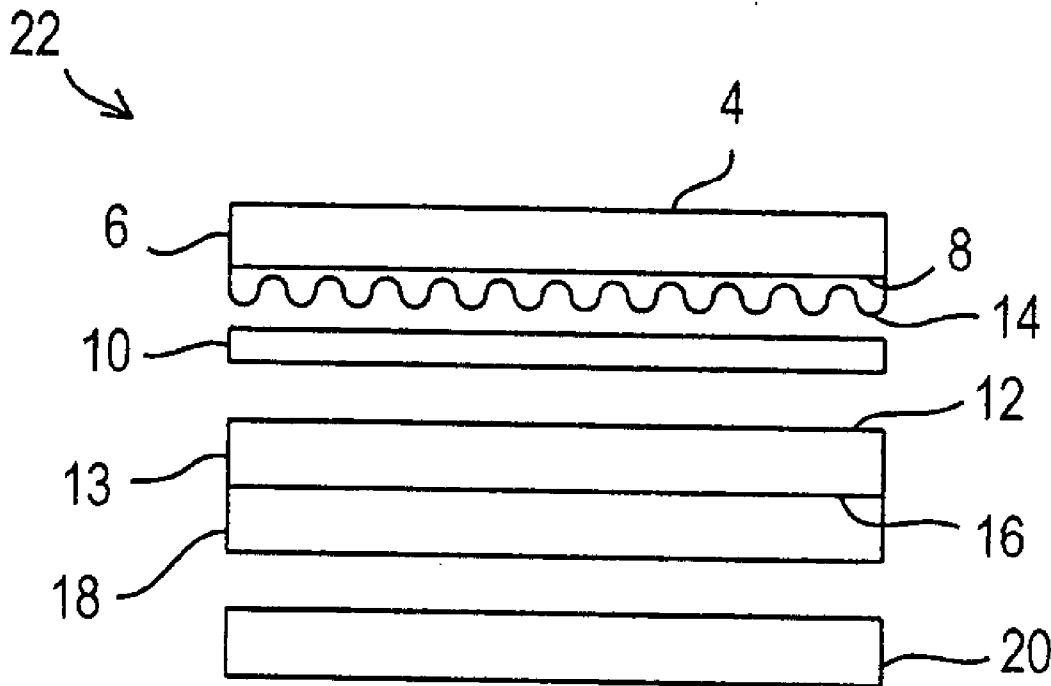

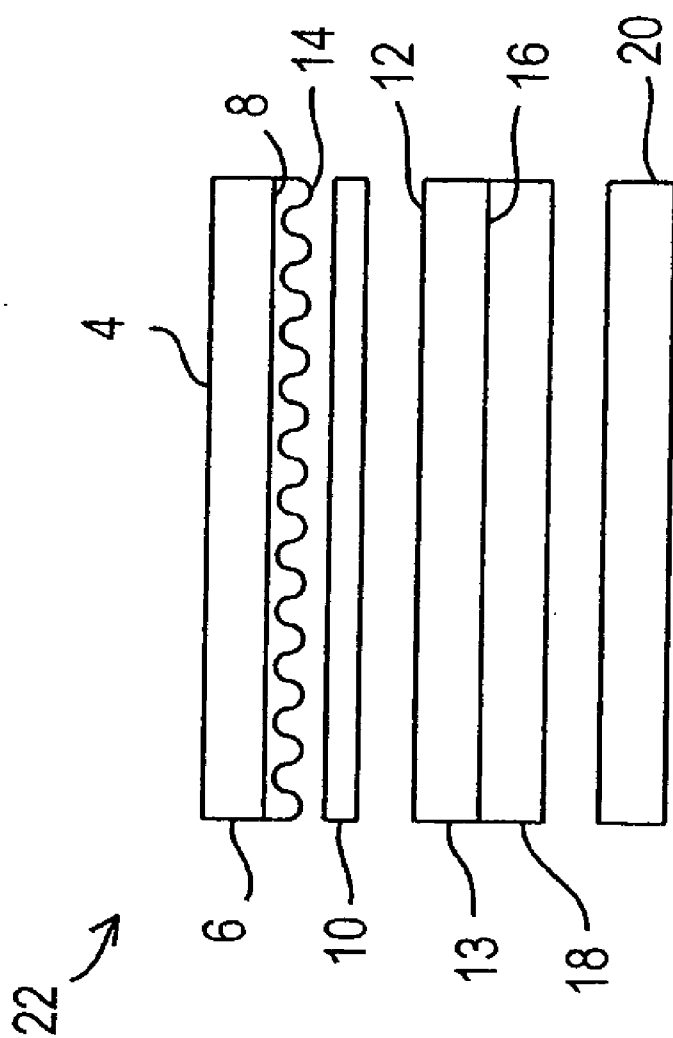

FIG. 1

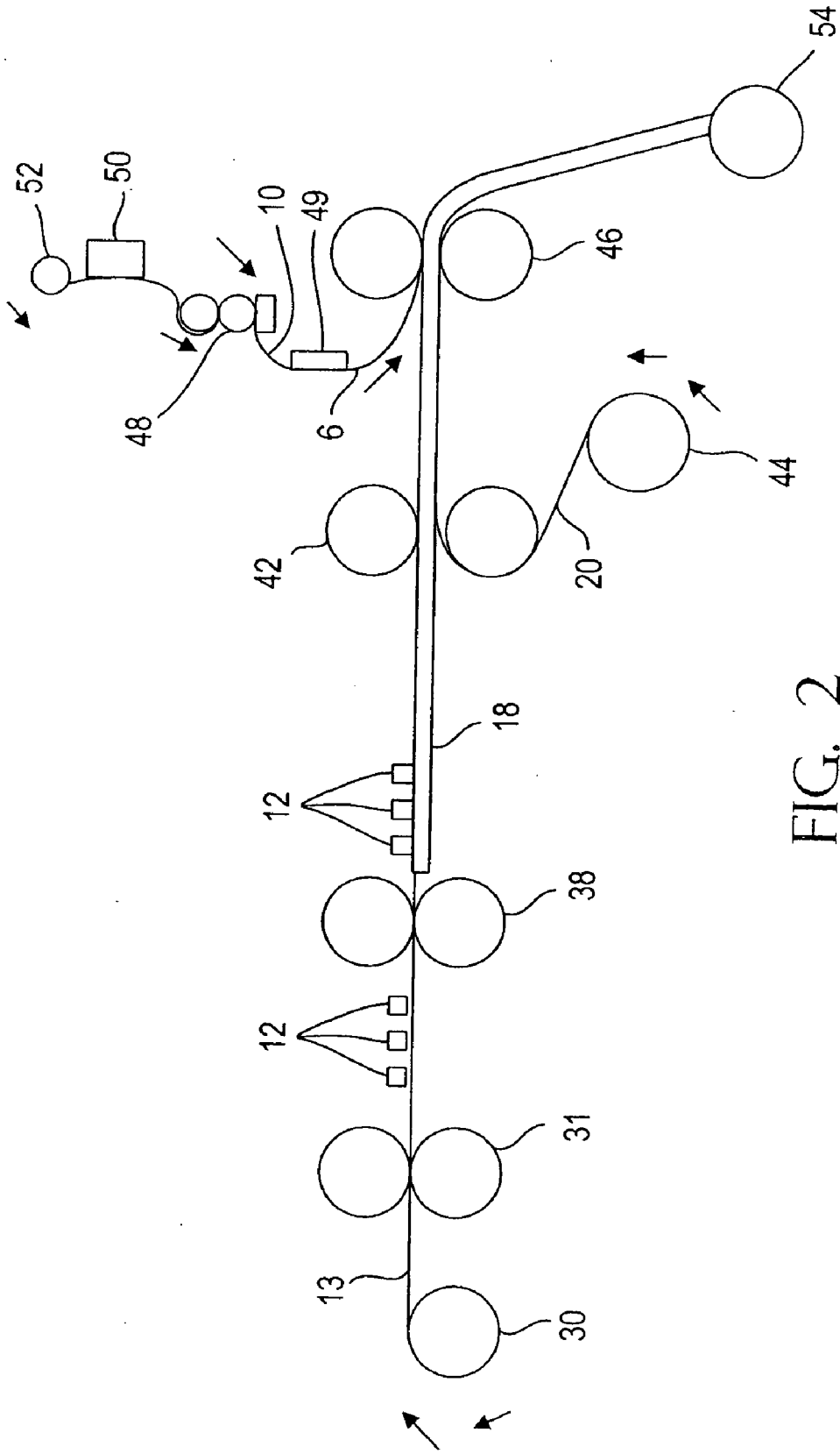

FIG. 2

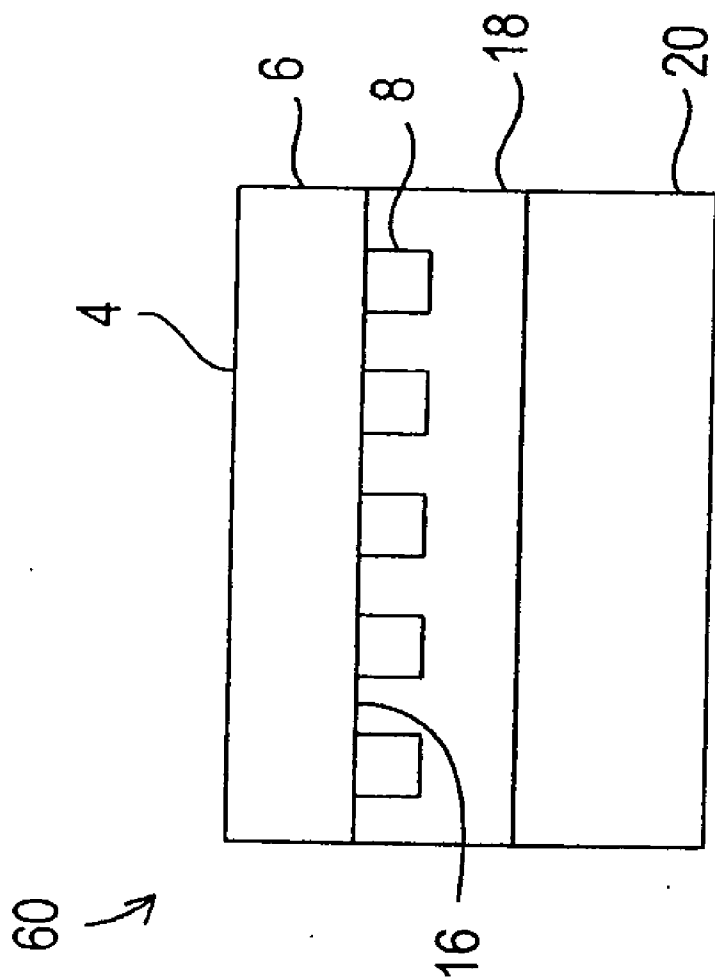

FIG. 3

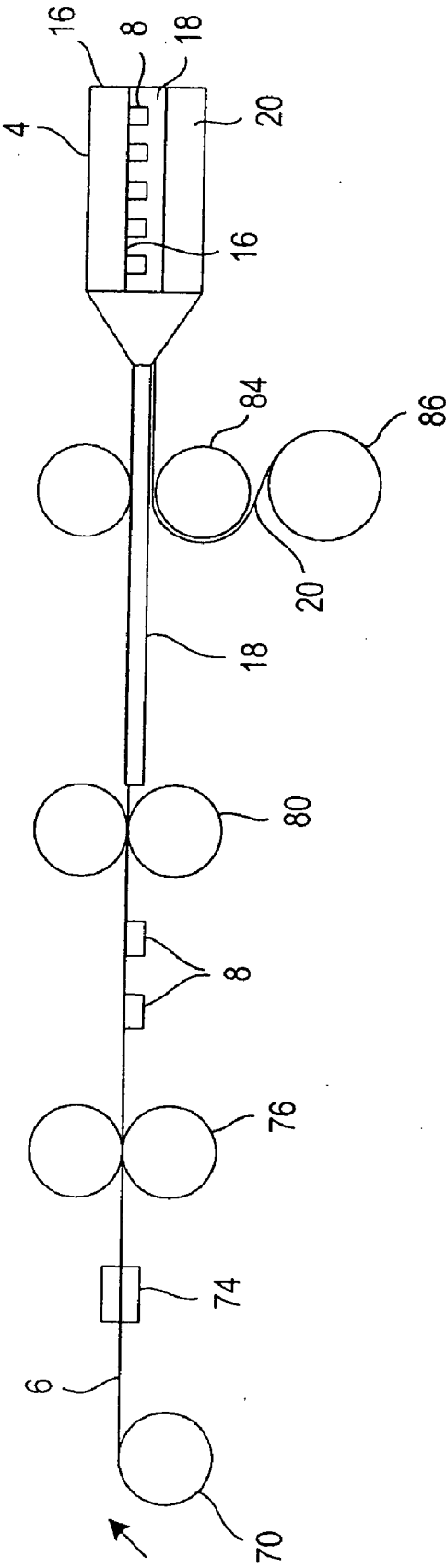

FIG. 4

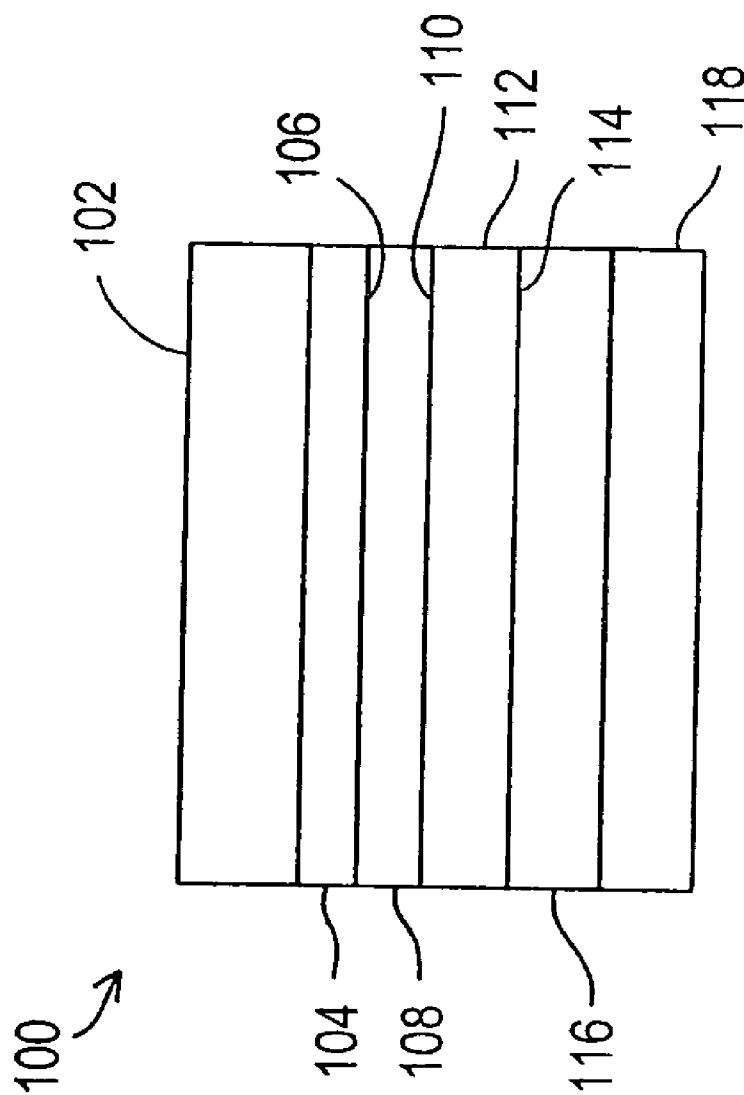

FIG. 5

DURABLE SUPPORTS FOR LABELING AND RELABELING OBJECTS

RELATED APPLICATIONS

[0001] The present application is a continuation application and claims priority from U.S. patent application Ser. No. 10/368,327, filed on Feb. 18, 2003. Applicant claims priority under 35 U.S.C. §120 as to said U.S. application, the entire disclosure of that application is hereby incorporated by reference.

FIELD OF THE INVENTION

[0002] This invention relates to supports used in labeling and relabeling objects such as containers, and, more particularly, to supports which provide a durable, reusable surface for pressure-sensitive adhesive labels.

BACKGROUND OF THE INVENTION

[0003] In the production and merchandising of goods, it is often desirable to make use of removable coupons or labels contained on containers or packages that function as redeemable retail coupons, inventory control labels, and the like. In these functions, it is desirable and often necessary that the coupon label not be prone to premature detachment during shipping and handling, yet be readily and cleanly removable.

[0004] Furthermore, inventory control labels, especially those affixed to reusable containers, are subject to abrasion during shipping and handling and to chemical attack by spillage of the container contents. Abrasion and chemical attack can destroy important information and result in premature detachment of the label and, in the case of relabeling, can increase the difficulty in removability of the label.

[0005] U.S. Pat. No. 4,767,654, to Riggsbee "DETACHABLE COUPON LABEL", describes a label structure appropriate for attaching to packages or containers which permits the coupon label to be readily detached without leaving a tacky residue and without the use of a coated release substance. Specifically, Riggsbee requires the use of London or dispersion forces to attach the coupon at a desirable release force, in the range of 10-100 g/inch width, to a base sheet without making use of either an adhesive or a coated release substance. To accomplish his objectives, Riggsbee requires that the coupon layer be the substrate for "casting" a thin extruded film of resin so as to retain detachability without damage to the substrate and without leaving a tacky residue.

[0006] U.S. Pat. No. 5,628,858, to Petrou "LABEL SYSTEM FOR REUSABLE CONTAINERS AND THE LIKE", requires the use of a multilayer laminate called a "placard" having a coated release substance on one side and means on the other side for adhesively securing the placard to the container. The placard is partially transparent with instructional printing applied to one surface. Pressure-sensitive labels are placed on the exposed release-coated surface of the placard. The labels contain indicia relating to the status of the container. When the status of the container changes, the label is removed and a new label is substituted on the placard. As a preferred embodiment, the placard is provided on one face with a coated silicone release substance.

[0007] U.S. Pat. No. 5,543,191, to Dronzek, Jr. et al "DURABLE SHEETS FOR PRINTING", teaches that composite pressure sensitive label sheets will print in hot laser printers without curling if they comprise at least three layers:

A. at least one base layer having a pressure sensitive adhesive on the bottom face, B. a printable surface layer on top of the base layer or layers, and C. a strippable protective backing on the pressure sensitive adhesive coated bottom face on the base layer or layers and if the thermal expansion or contraction characteristics of the printable layer B and the protective backing C are the same or substantially the same. In preferred embodiments, the backing C or layer A will be adhered to the pressure sensitive adhesive through a release coating, such as a poly(tetrafluoroethylene film) or more preferably a silicone resin, for the labels.

[0008] To summarize, in the present state of the art, it is known to use a laminated support structure ("placard") having a release-coated surface on one side and a pressure sensitive adhesive on the other backed by a removable release liner for attachment to a pressure sensitive coating of a label (Petrou). It is also known that one way to eliminate the use of a release coating on a support structure is to bond a thermoplastic film to a label by heat and pressure and, as well, not to use an adhesive (Riggsbee). Finally, it is known, but not preferable, to substitute a poly(tetrafluoroethylene) film for a silicone coating to release a support structure when the release liner is disposed of after only one use (Dronzek, Jr. et al).

[0009] It has now been found that durability of the multi-use label support structure will be vastly increased and reliability of the labeling and, especially, the re-labeling process will be enhanced by providing and using as a support structure a resin film having a controlled release surface made without using a coated release substance. "Durability" is increased, without limitation, in terms of ultraviolet (UV)-light resistance, abrasion resistance, anti-corrosives resistance, sterile packaging conditions resistance, chemical resistance, and the like. "Reliability" is enhanced by avoiding the use of a coated release substance, such as a silicone release coating, which, once abraded through the coating, causes the pressure sensitive adhesive-backed label or labels to stick and possibly even tear by contact with the underlying surface, and/or to distort or lose valuable printed information. Re-labeling is significantly improved because the substrate lends itself to use over and over again. Additionally, many temporary labels are removed and reapplied to other containers or areas for control and tracking purposes at various steps of manufacturing, packaging, storage and distribution, so the improved removability of the labels provided by the present invention is advantageous.

[0010] Accordingly, an object of the invention is to provide a durable support structure for use in labeling and relabeling using pressure-sensitive adhesive-backed labels.

[0011] Another object is to provide a durable support structure for use in labeling and relabeling using an adhesive-backed laminate having a disposable liner covering the adhesive.

[0012] These and other objects of the invention will become apparent from the present specification.

BRIEF DESCRIPTION OF THE DRAWINGS

[0013] In the drawings:

The invention is illustrated in the accompanying drawings in which:

[0014] **FIG. 1** is a block diagram view, partially exploded, of a first support structure constructed in accordance with the present invention;

[0015] FIG. 2 is a flow diagram of a process employed to make sheets or rolls from which to die-cut support structures according to the first embodiment (FIG. 1) of the present invention;

[0016] FIG. 3 is a block diagram view of a second support structure constructed in accordance with the present invention;

[0017] FIG. 4 is a flow diagram of a process employed to make sheets or rolls from which to die-cut support structures according to the second embodiment (FIG. 3) of the present invention; and

[0018] FIG. 5 is a block diagram of a support structure constructed in accordance with the prior art.

SUMMARY OF THE INVENTION

[0019] According to this invention, there are provided durable self-adhesive laminates in roll, sheet or fan-fold form for use as support structures for labeling and re-labeling of objects such as containers and the like, the laminates comprising:

[0020] (a) a thermoplastic resin film having (A) a label-receiving side and (B) an adhesive side, the label-receiving side consisting of a controlled-release surface without making use of a coated release substance and adapted to support a removable label attachable thereto by means comprising attraction forces between the resin film and the label;

[0021] (b) an adhesive having an ultimate release energy level greater than the attraction forces between the resin film and a removable label or labels, the adhesive being situated on the adhesive side of the resin film; and,

[0022] (c) optionally, a temporary backing in contact with the adhesive, the backing being adapted subsequently to be stripped from contact with the adhesive,

[0023] whereby the supports are suitable for mounting on an object to be labeled or re-labeled, after first having stripped any optional temporary backing therefrom, and any label or labels may, at the option of the user, be affixed to the label-receiving side and later separated from the resin film at a release force that effectuates such separation, without, at the same time, stripping the resin film from the object to be labeled or re-labeled.

[0024] Also contemplated as preferred embodiments of the present invention are laminates as defined above wherein:

(i) the removable label or labels comprise pressure-sensitive adhesive-backed label or labels;

[0025] (ii) the release force between the removable label or labels and the resin film having the controlled-release surface without making use of a release substance is about 5 to about 100 grams per inch width, and the adhesion energy level of the adhesive is greater than the release force between the label or labels and the resin film having the controlled-release surface without making use of a coated release substance; and especially those wherein the release force between the label or labels and the resin film having the controlled-release surface without making use of a coated release substance is about 20 to about 60 grams per inch width;

[0026] (iii) the label or labels comprise paper or a polymer film; especially those wherein the polymer is selected from polyethylene, polypropylene, poly(vinyl chloride), polyes-

ter, polyurethane, polyacrylate, polycarbonate, polyamide, polystyrene, fluoropolymer or a blend comprising any of the foregoing;

(iv) the resin film (a) comprises (polytetrafluoroethylene); and, special mention is made of those wherein:

[0027] (v) the resin film (a) is a composite of paper and resin layers, the composite having (A) a label-receiving side comprising poly(tetrafluoroethylene) and (B) an adhesive side, the resins comprising polyethylene, polypropylene, poly(vinyl chloride), polyester, polyurethane, polyacrylate, polycarbonate, polyamide, polystyrene, fluoropolymer or a blend comprising any of the foregoing. The resin film (a) can consist solely of poly(tetrafluoroethylene) in preferred embodiments, but for low cost purposes since this fluoropolymer is relatively expensive, it is a preferred option to build a composite with a lower cost layer, such as paper. In any case, however the fluoropolymer should be greater than about 0.0005 inch thick.

[0028] In another major aspect, the present invention contemplates a process for the preparation of a durable self-adhesive laminate in roll, sheet or fan-fold form for use as a support for labeling and re-labeling of objects such as containers and the like, the process comprising:

[0029] (1) providing a thermoplastic resin film having (A) a label-receiving side and (B) an adhesive side, the label-receiving side consisting of a controlled-release surface without making use of a coated release substance and adapted to support a removable label attachable thereto by means comprising attraction forces between the resin film and the label;

[0030] (2) locating on the adhesive side of the resin film an adhesive having an ultimate release energy level greater than the attraction forces between the resin film and a removable label or labels; and

[0031] (3) optionally, providing a temporary backing in contact with the adhesive, the backing being adapted subsequently to be stripped from contact with the adhesive, thereby providing a support suitable for mounting on an object to be labeled or re-labeled, after first stripping any optional temporary backing therefrom, and affixing any label or labels, at the option of the user, to the label-receiving side and later separating from the resin film at a release force effecting such separation, without, at the same time, stripping the resin film from the object to be labeled or re-labeled.

[0032] Special mention is made of preferred embodiments of the process or the invention wherein:

(i) the removable label or labels comprise a pressure-sensitive adhesive-backed label or labels;

[0033] (ii) the release force between the casting substrate and the resin film having the controlled-release surface without making use of a coated release substance is about 5 to about 100 grams per inch width, and the adhesion energy level of the adhesive is greater than the release force between the label or labels and the resin film having the controlled-release surface without making use of a coated release substance; especially those wherein the release force between the label or labels and the resin film having the controlled-release surface without making use of a coated release substance is about 20 to about 60 grams per inch width;

[0034] (iii) the label or labels comprise paper or a polymer film; especially those wherein the polymer is selected from

polyethylene, polypropylene, poly(vinyl chloride), polyester, polyurethane, polyacrylate, polycarbonate, polyamide, polystyrene, fluoropolymer or a blend comprising any of the foregoing;

(iv) the resin film (a) comprises (polytetrafluoroethylene); and special mention is made of support structures wherein:

[0035] (v) the resin film (a) is a composite of paper and resin layers, the composite having (A) a label-receiving side comprising poly(tetrafluoroethylene) and (B) an adhesive side comprising polyethylene, polypropylene, poly(vinyl chloride), polyester, polyurethane, polyacrylate, polycarbonate, polyamide, polystyrene, fluoropolymer or a blend comprising any of the foregoing.

[0036] In another of its major aspects, the present invention contemplates a method of labeling or relabeling an object comprising:

[0037] a) providing a laminated support structure for pressure-sensitive adhesive-backed labels, the support structure comprising a thermoplastic resin film having (A) a label-receiving side and (B) an adhesive side, the label-receiving side consisting of a controlled-release surface without making use of a coated release substance and adapted to support a removable label attachable thereto by means comprising attraction forces between the resin film and the label substrate having a release coated face and an adhesive coated face, and a liner covering the adhesive coating;

b) removing the liner from the adhesive coated face;

c) substantially permanently attaching the support structure to the object by adhering the laminated support structure to the object using the adhesive coated face; and

d) placing a pressure-sensitive adhesive coated label on the label-receiving side consisting of the controlled-release surface without making use of a coated release substance of the support structure.

[0038] Preferred embodiments of this aspect include a method as defined, including the step comprising:

e) removing the label from the support structure while leaving the support structure adhered to the object;

a method as defined, including the step comprising

[0039] f) replacing the label with another adhesive coated label having different indicia printed thereon by adhering the adhesive coating of the another label to the label-receiving side consisting of the controlled-release surface without making use of a coated release substance of the support structure.

[0040] Special mention is made of such methods wherein the object is a product container.

[0041] In another aspect of the invention, a programmable electronic tag also known as a transponder such as a radio frequency identification (RFID) transmitter is captured between layers of the lamination to produce a smart card or label for automatic identification and control.

[0042] RFID is based around radio or electromagnetic propagation which has the ability to allow energy to penetrate through paper or polymeric labels of a laminate to read a tag that may or may not be visible.

[0043] The basic RFID system consists of three components: an antenna or coil, a transceiver also known as an interrogator (with decoder) and an RF tag (also known as a transponder) that is electronically programmed with information. The antenna emits radio signals to activate the tag and read or write data to it and acts as the conduit between the transponder (tag) and transceiver which controls the systems data acquisition and communication.

[0044] Active RFID tags are powered by an internal battery and can be typically read from and written to. Passive RFID tags operate without a separate external power source and obtain operating power generated from the reader. Passive tags are much smaller, lighter and less expensive than active tags and have an extended operational lifetime but require shorter read ranges and a higher powered reader.

[0045] U.S. Pat. No. 5,448,110 to Tuttle, which is incorporated by reference in its entirety, discloses enclosed transponders that are suitable for mass production in web sheet and tape formats or for use as stickers affixed to a device.

[0046] U.S. Pat. No. 5,497,140 to Tuttle, which is incorporated by reference in its entirety, discloses a miniature RFID system captured between layers for use as a postage stamp and the like.

[0047] Our invention differs from those of Tuttle where through differential treatment, we are providing a means for a device to be embedded between layers of the lamination of the invention providing a removable segment, card, coupon, tag or label with a smart embedded device. The device can be read or written at any time and can then subsequently be removed with the removable piece through differential treatment and subsequently re-read or written to throughout the useful life of the item.

DETAILED DESCRIPTION OF THE INVENTION

[0048] Referring to **FIG. 1**, a support structure of this invention comprising a multi-layer laminate **2** is shown. The laminate **2** includes a support structure comprising, as essential elements **4**, **6**, **16** and **18**, which are, reading from the top down: release face **4**, made without the use of a coating of release substance, comprising resin film **6**, for example, a poly(tetrafluoroethylene) resin film with release properties throughout, and adhesive face **16** on which is located layer **18** of adhesive. Also illustrated in the embodiment of **FIG. 1** are optional, non-critical, but preferred elements, reverse printed indicia **8**, direct printed indicia **12**, composite paper or polymeric interlayers **13**, bonded to resin film **6** through laminating adhesive layer **10**, and features such as flame, chemical-, or corona-treated surface(s) **14** for enhancing adhesive bonding to the fluoropolymer film, and throw-away release liner **20**.

[0049] Referring to **FIG. 2**, one preferred process to make a laminated support structure of the invention is illustrated in flow diagram form. Plastic film, e.g., oriented polypropylene or polyethylene terephthalate **13** is supplied by roll **30** and is printed at station **31** with indicia, e.g., "LABEL HERE"**12** on its top side. At station **38** pressure-sensitive adhesive **18** is applied to the bottom side, and after proceeding to station **42**, the laminate emerges from the station covered with a protective layer of release paper **20** supplied by paper roll **44**. Next, the web proceeds to lamination

station 46 wherein there is provided a top layer of a release film 6 not having been made by coating with a release layer. In this case a poly(tetrafluoroethylene) film, 0.0005 inch thick, is supplied from roll 52, passed through corona-treater 50, and picks up a coating of laminating adhesive 10 at station 48, passing through a web turner 49, before adhering to the top side of the web entering laminating station 46. At the end of the line the support structure is wound up on roll 54.

[0050] Referring to FIG. 3, another preferred support structure of this invention comprising a multi-layer laminate 60 is shown. The laminate 60 includes a support structure comprising, as essential elements 4, 6, 16, and 18, which are, reading from the top down: release face 4, made without the use of a coating of release substance, comprising resin film 6, for example, a poly(tetrafluoroethylene) resin film with release properties throughout, and adhesive face 16 on which is located layer 18 of adhesive. Also illustrated in the embodiment of FIG. 3 are optional, non-critical, but preferred elements, reverse printed indicia 8, optionally included composite paper or polymeric interlayers (not shown), bonded to resin film 6 through a laminating adhesive layer (not shown), and features such as flame, chemical-, or corona-treated surface(s) for enhancing printing (not shown), and throw-away release liner 20.

[0051] Referring to FIG. 4, one preferred process to make a laminated support structures of FIG. 3. of the invention is illustrated in flow diagram form. Plastic film, e.g., poly(tetrafluoroethylene) film 6 is supplied by roll 70 and moves through corona treater 74 and then to print station 76 wherein it is provided with indicia, e.g., "LABEL HERE" 8 on its bottom side. At station 80 pressure-sensitive adhesive 18 is applied to the bottom side of the indicia-printed web, and after proceeding to release paper- or film-application station 84, the laminate according to the present invention (shown partially exploded and enlarged for clarity of illustration) emerges from the station covered with a protective layer of release paper or film 20 supplied by paper roll 86. The laminated support structure can be wound up in large rolls (not shown).

[0052] Further processing is usually carried out by the end-user in ways well known to those skilled in this art. For example, large rolls can be slit into smaller rolls, and the smaller rolls can be fed to die-cutting machines and/or to fan-folders to produce sheets or detachable forms of suitable size for labeling and re-labeling.

[0053] The prior art support structure ("placard") is shown in FIG. 5. Reading from the top down placard 100 comprises release coating 102 e.g., a silicone coating, on top of clear film 104 which optionally can be reverse-printed with indicia 106. Next there is provided a layer of adhesive 108, optional directly printed indicia layer 110 then a white film 112 then layer of reverse-printed indicia 114. Next there is provided layer 116 of pressure sensitive adhesive and finally paper release layer 118.

[0054] Referring again to FIG. 5, the method for relabeling taught by the prior art comprises: first, removing the release-coated liner 118 from the lamination to provide a placard. The placard 100 is applied to a container such that the adhesive 116 secures the stripped placard (i.e., 102, 104, 116 and 118) firmly to the container (not shown) with the release coating 102 outermost and the printing 114 clearly visible. Then a label (not shown), having an exposed adhesive layer, is applied to the placard such that the label's adhesive contacts the release coating 102. The label carries

printed indicia relating to the container and/or its contents. When desired, such as when the container is refilled, the label is removed and a new label (not shown) carrying new information is applied to the placard.

[0055] The placard allows pressure-sensitive labels to be easily removed and replaced as many times as necessary. The labels can be removed without ripping or tearing. The labels are not covered by a plastic envelope which results in better bar code scanning. In addition, the container stays free of label and adhesive build-up. Moreover, because of the release surfaces made without coating with release substances any commercially available label can be used including those with inexpensive permanent pressure sensitive adhesive coatings rather than more expensive removable coatings.

[0056] The following examples illustrate the present invention and compare it with the prior art. They are not to be construed to limit the claims in any manner whatsoever.

EXAMPLE 1

[0057] The following procedure is used to make a first embodiment of this invention as generally set forth in FIG. 1:

1—A base film substrate of 4 mil white High Density Polyethylene from Blako Industries was corona treated on both sides to a minimum 42 dyne surface tension.

[0058] 2—To one side was applied pressure sensitive adhesive Covinax 377-02 from Franklin International using a #20 laboratory metering rod. The adhesive was dried using a conventional laboratory oven and yielded a dry deposit approximately 1.1 mil of dry pressure sensitive adhesive.

3—A 40# silicone coated Super Calendared Kraft (bleached) from Siltech with L7 release level was laminated to the tacky pressure sensitive adhesive as a protective releasable backing sheet.

4—A sheet of DuPont PFA grade 50 gauge fluoropolymer resin film was corona treated on one side to enhance the surface for bonding.

[0059] 5—Urethane resin laminating adhesive PD384-30 available from Process Resources Corp with 3 parts of Polyfunctional Aziridine crosslinking agent was applied to the corona treated surface of the PFA resin release film from step #4 using a #10 laboratory metering rod. The coating was dried in a conventional laboratory oven and the coated surface was then pressure laminated through the nip point of a laminating roll to the surface of the exposed corona treated High Density Polyethylene surface of the structure made in step #3. The lamination was allowed to cure for complete bonding of the surfaces.

EXAMPLE 2

[0060] The following procedure is used to make a second embodiment of this invention as generally set forth in FIG. 3:

1—A base film substrate of white Oriented Polypropylene known as IML2 from Applied Extrusion Technologies was corona treated on both sides to a minimum 42 dyne surface tension.

[0061] 2—To the non print side as specified by the manufacturer was applied pressure sensitive adhesive Covinax 377-02 from Franklin International using a #20 laboratory

metering rod. The adhesive was dried using a conventional laboratory oven and yielded a dry deposit approximately 1.1 mil of dry pressure sensitive adhesive.

3—A 40# silicone coated Super Calendared Kraft (bleached) from Siltech with L7 release level was laminated to the tacky pressure sensitive adhesive as a protective releasable backing sheet.

4—A sheet of DuPont PFA grade 100 gauge fluoropolymer resin film was corona treated on one side to enhance the surface for bonding.

5—Indicia was applied to the exposed print surface of the oriented polypropylene film in the structure from step #3 using a permanent marker to simulate printed indicia.

[0062] 6—Pressure sensitive laminating adhesive PD252 available from Process Resources Corp was applied to the corona treated surface of the print surface with simulated indicia from step #5 using a #12 laboratory metering rod. The coating was dried in a conventional laboratory oven and the coated surface was then pressure laminated through the nip point of a laminating roll to the corona treated surface of the PFA resin film made in step #4. The lamination was allowed to set up and build adhesion for optimum bonding of the surfaces.

COMPARATIVE EXAMPLE A

[0063] The following procedure is used to make an embodiment of the prior art as generally set forth in FIG. 5:

Actual Placards with patent markings U.S. Pat. Nos. 5,417,790 and 5,628,858 were used for comparative purposes. The structure appears to be from top down:

Silicone coated clear oriented polypropylene

Permanent laminating adhesive

Indicia “Apply Shipping Labels On This Area Only”

White Oriented Polypropylene

Pressure Sensitive Adhesive

Removable silicone coated backing

[0064] The following test methods are used to compare the respective laminates of Examples 1 and 2 with the placard of Comparative Example A of the prior art:

[0065] Paper based pressure sensitive labels supplied by United Parcel Service that are applied for tracking purposes

were used for test purposes and are representative of the types of temporary short life cycle labels used for bar coding and other means of identification.

Each example and the control were tested for peel adhesion of the labels 1 hour after label application using a conventional peel tester at 180 degree peel angle.

Chemical Resistance Test

[0066] Each example and the control were applied with cleaning solution Ultra Mr. Clean available from Proctor & Gamble in an area wider than the width of the label to be applied. The cleaning solution for household cleaning should be representative and probably even less aggressive than industrial cleaning solutions used to clean bins, tote containers and the like in industrial environments. After 1 hour, the cleaning solution was wiped off with a cotton rag until all residue was removed. It was noticed that the silicone coated surface of the current art placard was marred and had visually changed in the area of contact with the detergent.

Industrial Durability Test

[0067] A sample of each of the examples and the control was affixed to a plastic reusable industrial tote container manufactured by Schultz typically used for transporting shipments of chemicals or other ingredients which are then shipped back and cleaned before reuse. Every time it is used a new label is applied so this is a practical test for testing. A high pressure washer from Land Model OHW40021B used in practice to clean residue from the inside and outside of reusable containers with high pressure water set at 150 degrees F. in this case was used. Each of the example placards and the control were exposed to 30 seconds of “washing” then the placards were removed and dried before the test labels were applied in the washed area.

Abrasion Test

[0068] A sample of each of the examples and the control was tested for abrasion resistance using “Emery Fine Resin Bond Cloth.” Each specimen was rubbed 10 strokes by hand to abrade the surface to simulate abrasion of the surface in repeated handling and use. Labels were then applied to the abraded area. Peel tests on the peel tester described earlier were performed using the test labels on the samples and control at 1 hour and 24 hour label dwell times. Peel measurement strength range is measured in grams. The range of peel was estimated from the lowest reading to the highest with +/-20 grams a reasonable measurement error.

[0069] The results of testing are set forth in Table 1:

TABLE 1

	AS MADE OR SUPPLIED	CHEMICAL RESISTANCE	DURABILITY	ABRASION RESISTANCE
SAMPLE	1/24 hour dwell	1/24 hour Dwell	1/24 hour Dwell	1/24 hour Dwell
CONTROL	30–75/ 40–90	30–500/ Label Destruct	50–500/ 70–500 Very Spotty	45–270/ 50–350 Very Spotty
Example #1	40–90/ 60–115	40–85/ 60–150	–80/ 60–130	50–75/ 55–130
Example #2	40–90/ 65–100	35–80 65–140	30–75/ 70–140	40–70/ 60–120

[0070] The test data are evidence of the enhanced durability achieved in accordance with the invention defined by the claims herein.

[0071] The patents, applications, publications and test methods mentioned above are incorporated herein by reference.

[0072] Many variations of the present invention will suggest themselves to those skilled in the art in light of the above detailed description.

[0073] All such obvious modifications are within the full intended scope of the appended claims.

I claim:

1. A method of labeling or relabeling an object comprising:

- a) providing a laminated support structure for pressure-sensitive adhesive-backed labels, said support structure comprising at least a fluoropolymer film having (A) a label-receiving side and (B) an adhesive side, said label-receiving side consisting of a controlled-release surface without making use of a coated release substance and adapted to support a removable label attachable thereto by means comprising attraction forces between said fluoropolymer film and said label, said adhesive side of the support structure having an adhesive coated face and a liner covering said adhesive side of said support structure, wherein said laminated support structure includes a transponder being electronically programmed with information;
- b) removing said liner from said adhesive coated face;
- c) substantially permanently attaching the support structure to the object by adhering said laminated support structure to said object using said adhesive coated face; and
- d) placing a pressure-sensitive adhesive coated label on said label-receiving side of said support structure consisting of said controlled-release surface without making use of a coated release substance.

2. A method as defined in claim 1, including the step comprising:

- e) removing said label from the support structure while leaving the support structure adhered to the object.

3. A process as defined in claim 2, including the step comprising:

- f) replacing said label with another adhesive coated label having different indicia printed thereon by adhering the adhesive coating of said another label to the said label-receiving side of said support structure consisting of said controlled-release surface without making use of a coated release substance.

4. The process of claim 1, wherein the object is a product container.

5. The process of claim 1, wherein said support structure is provided from multiple layers containing at least one fluoropolymer film on the label receiving side of said support structure.

6. The process of claim 5, wherein said multiple layers may be provided from the group of materials comprising plastic or paper together with adhesive.

7. The process of claim 5, wherein said transponder is provided by including at least one RFID tag with the support structure.

8. The process of claim 2, wherein said transponder is provided by including at least one RFID tag with the support structure.

9. The process of claim 3, wherein said transponder is provided by including at least one RFID tag with the support structure.

10. A durable self-adhesive laminate in roll, sheet or fan-fold form for use as a support for labeling and relabeling of objects such as containers and the like, said laminate comprising:

- (a) a fluoropolymer film having (A) a label-receiving side and (B) an adhesive side, said label-receiving side consisting of a controlled-release surface without making use of a coated release substance and adapted to support a removable label attachable thereto by means comprising attraction forces between said fluoropolymer film and said label;
- (b) an adhesive having an ultimate release energy level greater than the attraction forces between the fluoropolymer film and a removable label or labels, said adhesive being situated on the adhesive side of said fluoropolymer film;
- (c) optionally, a temporary backing in contact with the adhesive, said backing being adapted subsequently to be stripped from contact with the adhesive, whereby the support is suitable for mounting on an object to be labeled or re-labeled, after first having stripped any optional temporary backing therefrom, and any label or labels may, at the option of the user, be affixed to the label-receiving side and later separated from the fluoropolymer film at a release force that effectuates such separation, without, at the same time, stripping the fluoropolymer film from the object to be labeled or re-labeled; and,
- (d) a transponder, provided with said laminate, said transponder being electronically programmed with information.

11. The laminate of claim 10, wherein said transponder comprises an RFID tag.

* * * * *