



US00D771533S

(12) **United States Design Patent** (10) **Patent No.:** **US D771,533 S**  
**Kapitonov** (45) **Date of Patent:** **\*\* Nov. 15, 2016**

(54) **VEHICLE FRONT FASCIA**  
(71) Applicant: **GM GLOBAL TECHNOLOGY OPERATIONS LLC**, Detroit, MI (US)  
(72) Inventor: **Vladimir Kapitonov**, Farmington, MI (US)  
(73) Assignee: **GM Global Technology Operations LLC**, Detroit, MI (US)  
(\*\*) Term: **15 Years**

D608,249 S 1/2010 Peters  
D608,690 S 1/2010 Folden et al.  
D608,691 S 1/2010 Zak, Jr. et al.  
D609,608 S 2/2010 Boniface et al.  
D611,387 S 3/2010 Thompson et al.  
D611,879 S 3/2010 Kim et al.  
D612,297 S 3/2010 Peters et al.  
D613,645 S 4/2010 Song et al.  
D615,458 S 5/2010 Thompson et al.  
D618,595 S 6/2010 Ware et al.  
D623,090 S 9/2010 Cox et al.  
D627,262 S 11/2010 Ikeda et al.  
D635,488 S 4/2011 Phipps

(Continued)

(21) Appl. No.: **29/536,993**

(22) Filed: **Aug. 21, 2015**

(51) **LOC (10) Cl.** ..... **12-08**

(52) **U.S. Cl.**

USPC ..... **D12/169**

(58) **Field of Classification Search**

USPC ..... D12/86-92, 163-172; 293/102-155;  
296/35.2, 193.09, 193.1, 203.02  
CPC ..... B60R 19/02; B60R 19/023; B60R 19/18;  
B60R 19/24; B60R 19/44; B60R 19/48;  
B60R 19/56; B60R 2019/527; B60R  
2019/1886

See application file for complete search history.

(56) **References Cited**

**U.S. PATENT DOCUMENTS**

D563,843 S \* 3/2008 Kido ..... D12/169  
D570,742 S 6/2008 Takagi et al.  
D592,105 S 5/2009 Dean et al.  
D597,447 S 8/2009 Folden  
D600,595 S 9/2009 Nakamura et al.  
D601,925 S 10/2009 O'Donnell  
D603,755 S 11/2009 Peters  
D604,203 S 11/2009 O'Donnell  
D605,082 S 12/2009 Munson  
D605,083 S 12/2009 Manoogian, II et al.  
D605,977 S 12/2009 Zipfel et al.  
D605,978 S 12/2009 Wolff et al.

**OTHER PUBLICATIONS**

"2009 Cadillac STS." topspeed.com. Posted Aug. 11, 2008. Accessed Aug. 1, 2016. Available online at URL: <<http://www.topspeed.com/cars/cadillac/2009-cadillac-sts-ar61984.html>>.\*

(Continued)

*Primary Examiner* — Cathron Brooks  
*Assistant Examiner* — Christian P McLean  
(74) *Attorney, Agent, or Firm* — Reising Ethington P.C.

(57) **CLAIM**

The ornamental design for a vehicle front fascia, as shown and described.

**DESCRIPTION**

FIG. 1 is a perspective view of the vehicle front fascia; FIG. 2 is a bottom view thereof; FIG. 3 is a left side elevation view thereof; and, FIG. 4 is a front view thereof. The right side elevation view of the vehicle front fascia is omitted because the right side elevation view is identical to the left side elevation view. And the broken lines shown in the drawings depict portions of the vehicle front fascia that form no part of the claimed design.

**1 Claim, 2 Drawing Sheets**

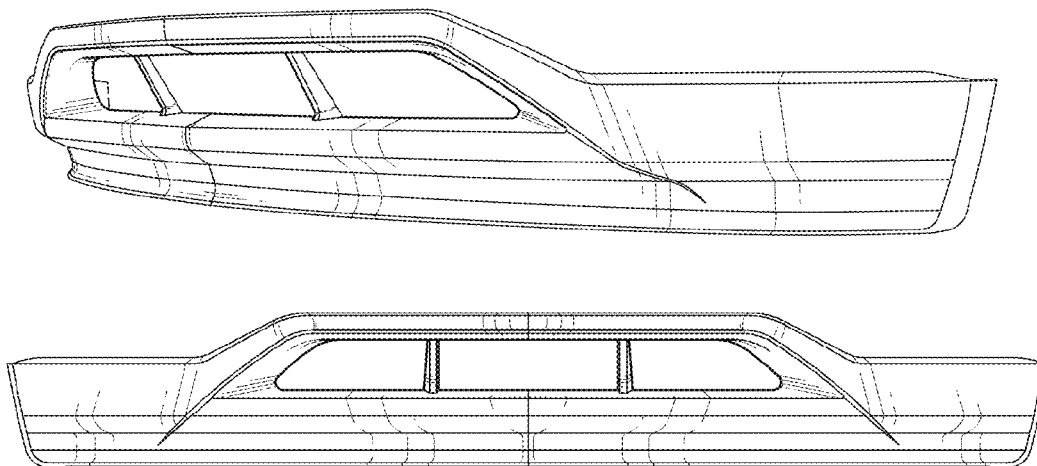

(56)

References Cited

U.S. PATENT DOCUMENTS

D644,147 S 8/2011 Suh et al.  
 D644,567 S 9/2011 Kozub  
 D650,721 S \* 12/2011 Galante ..... D12/91  
 D657,718 S 4/2012 Zipfel et al.  
 D659,052 S 5/2012 Ware et al.  
 D659,053 S 5/2012 Ware et al.  
 D664,894 S \* 8/2012 Huet ..... D12/91  
 D668,182 S 10/2012 Barba Franco et al.  
 D668,183 S 10/2012 Smart  
 D669,003 S \* 10/2012 Koizumi ..... D12/169  
 D670,606 S \* 11/2012 Frenzel ..... D12/91  
 D670,624 S \* 11/2012 Koehl ..... D12/169  
 D678,820 S 3/2013 Song et al.  
 D678,821 S 3/2013 Ikeda et al.  
 D680,909 S 4/2013 Munson et al.  
 D680,910 S 4/2013 David  
 D684,899 S 6/2013 Baker  
 D686,536 S 7/2013 McCabe et al.  
 D692,798 S 11/2013 Thurber  
 D692,799 S 11/2013 Smith et al.  
 D696,157 S 12/2013 Loeb  
 D699,629 S 2/2014 Ikeda et al.  
 D700,871 S 3/2014 O'Donnell et al.  
 D703,103 S 4/2014 Lee  
 D704,103 S 5/2014 Mack et al.  
 D705,132 S 5/2014 Ware et al.  
 D705,699 S 5/2014 Ware et al.  
 D712,319 S \* 9/2014 Mays ..... D12/163

D713,298 S 9/2014 Dyson  
 D713,764 S 9/2014 Ferlazzo et al.  
 D716,696 S 11/2014 Thole et al.  
 D716,706 S 11/2014 Thole et al.  
 D716,709 S 11/2014 Thole et al.  
 D717,696 S 11/2014 Thole et al.  
 D718,189 S 11/2014 Krieg et al.  
 D718,683 S 12/2014 Thole et al.  
 D722,282 S 2/2015 Loeb  
 D722,533 S 2/2015 Thole et al.  
 D722,534 S 2/2015 Munson et al.  
 D724,510 S 3/2015 McMahan et al.  
 D725,001 S 3/2015 McMahan et al.  
 D727,221 S \* 4/2015 Rugar ..... D12/163  
 D730,776 S 6/2015 Smart  
 D730,783 S 6/2015 Henriques et al.  
 D731,371 S \* 6/2015 Morikawa ..... D12/169  
 D732,435 S 6/2015 Mackay  
 D735,627 S 8/2015 Smith et al.  
 D736,451 S 8/2015 Smith et al.  
 D740,184 S \* 10/2015 Blanski ..... D12/163  
 D744,901 S \* 12/2015 Fulgenzi ..... D12/92  
 D749,022 S \* 2/2016 Nakahara ..... D12/169

OTHER PUBLICATIONS

“2006 Dodge CHarger RT.” topspeed.com. Posted Nov. 29, 2005. Accessed Aug. 1, 2016. Available online at URL: <<http://www.topspeed.com/cars/dodge/2006-dodge-charger-rt-ar449.html>>.\*

\* cited by examiner

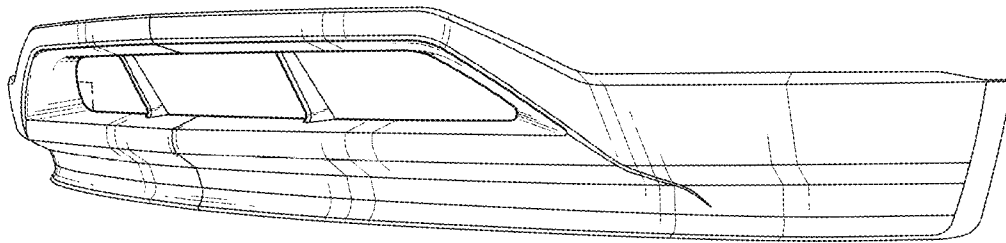

Fig. 1

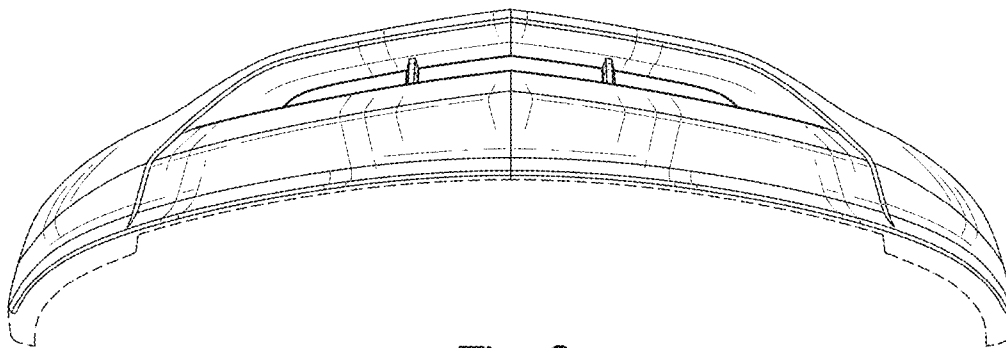

Fig. 2

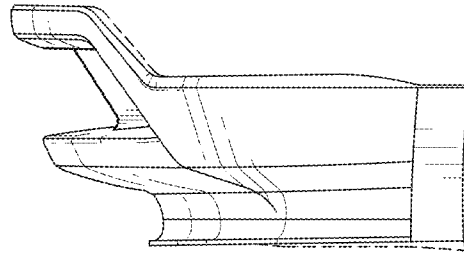

Fig. 3

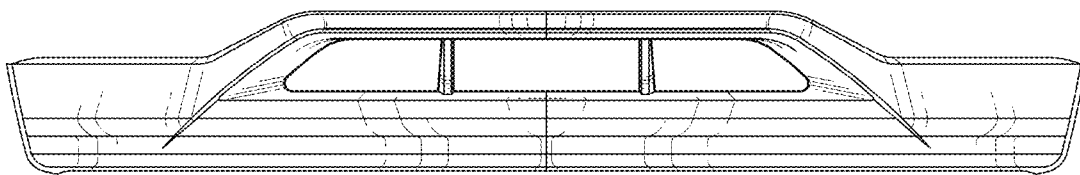

Fig. 4