

(19) World Intellectual Property Organization
International Bureau



(43) International Publication Date
2 February 2006 (02.02.2006)

PCT

(10) International Publication Number
WO 2006/011062 A2

- (51) International Patent Classification: **Not classified**
- (21) International Application Number:
PCT/IB2005/003267
- (22) International Filing Date: 20 May 2005 (20.05.2005)
- (25) Filing Language: English
- (26) Publication Language: English
- (30) Priority Data:
60/573,090 20 May 2004 (20.05.2004) US
- (71) Applicant (for all designated States except US): **ALBA-TROS TECHNOLOGIES GMBH & CO. KG** [DE/DE];
Lise-Meitner-Strasse 7, 48161 Münster (DE).
- (72) Inventors; and
- (75) Inventors/Applicants (for US only): **BARTETZKO, Norbert** [DE/DE]; Beverfördering 54, 59071 Hamm (DE). **SPECHT, Bernfried** [DE/DE]; Stadtbörne 3, 48324 Sendenhorst (DE). **KUNZ, Michael** [DE/DE]; Scharnhorststr. 36, 48151 Muenster (DE).
- (81) Designated States (unless otherwise indicated, for every kind of national protection available): AE, AG, AL, AM,

AT, AU, AZ, BA, BB, BG, BR, BW, BY, BZ, CA, CH, CN, CO, CR, CU, CZ, DE, DK, DM, DZ, EC, EE, EG, ES, FI, GB, GD, GE, GH, GM, HR, HU, ID, IL, IN, IS, JP, KE, KG, KM, KP, KR, KZ, LC, LK, LR, LS, LT, LU, LV, MA, MD, MG, MK, MN, MW, MX, MZ, NA, NG, NI, NO, NZ, OM, PG, PH, PL, PT, RO, RU, SC, SD, SE, SG, SK, SL, SM, SY, TJ, TM, TN, TR, TT, TZ, UA, UG, US, UZ, VC, VN, YU, ZA, ZM, ZW.

- (84) Designated States (unless otherwise indicated, for every kind of regional protection available): ARIPO (BW, GH, GM, KE, LS, MW, MZ, NA, SD, SL, SZ, TZ, UG, ZM, ZW), Eurasian (AM, AZ, BY, KG, KZ, MD, RU, TJ, TM), European (AT, BE, BG, CH, CY, CZ, DE, DK, EE, ES, FI, FR, GB, GR, HU, IE, IS, IT, LT, LU, MC, NL, PL, PT, RO, SE, SI, SK, TR), OAPI (BF, BJ, CF, CG, CI, CM, GA, GN, GQ, GW, ML, MR, NE, SN, TD, TG).

Published:
— without international search report and to be republished upon receipt of that report

[Continued on next page]

(54) Title: PRINTABLE HYDROGEL FOR BIOSENSORS

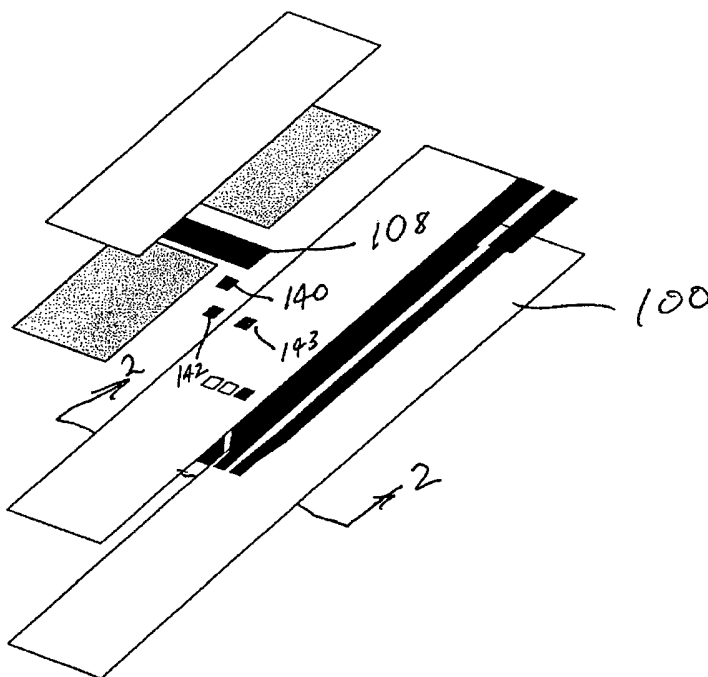

(57) Abstract: Methods and apparatus are provided for manufacturing an analyte detecting device. In one embodiment, the method comprises providing a substrate, applying a plurality of layer of materials on said substrate; applying a layer containing at least one mediator; and screen printing a hydrogel on the layer.

WO 2006/011062 A2



For two-letter codes and other abbreviations, refer to the "Guidance Notes on Codes and Abbreviations" appearing at the beginning of each regular issue of the PCT Gazette.

PRINTABLE HYDROGEL FOR BIOSENSORS

5 BACKGROUND OF THE INVENTION

Technical Field:

The technical field relates to analyte detecting devices, and more specifically, coatings for improving glucose measurement.

Background Art:

10 Test strips are known in the medical health-care products industry for analyzing analyte levels such as but not limited to, glucose levels in blood. For this type of analysis, a drop of blood is typically obtained by making a small incision in the fingertip, creating a small wound, which generates a small blood droplet on the surface of the skin. A test strip is brought by the user to the blood droplet at the wound and engaged in a manner to
15 bring blood to an analysis site on the test strip. The test strip is then coupled to a metering device which typically uses an electrochemical technique to determine the amount of glucose in the blood.

Early methods of using test strips required a relatively substantial volume of blood to obtain an accurate glucose measurement. This large blood requirement made the
20 monitoring experience a painful one for the user since the user may need to lance deeper than comfortable to obtain sufficient blood generation. Alternatively, if insufficient blood is spontaneously generated, the user may need to "milk" the wound to squeeze enough blood to the skin surface. Neither method is desirable as they take additional user effort and may be painful. The discomfort and inconvenience associated with such lancing
25 events may deter a user from testing their blood glucose levels in a rigorous manner sufficient to control their diabetes.

A further impediment to patient compliance is the amount of time that it takes for a glucose measurement to be completed. Known devices can take a substantial amount of time to arrive at a glucose level. The more time it takes to arrive at a measurement, the
30 less the likely that the user will stay with their testing regime.

Accordingly, improved test strips are desired to increase user compliance and reduce the hurdles associated with analyte measurement.

SUMMARY OF THE INVENTION

The present invention provides solutions for at least some of the drawbacks discussed above. Specifically, some embodiments of the present invention provide an improved apparatus for measuring analyte levels in a body fluid. The present invention also provided improved techniques for manufacturing such analyte detecting devices. At least some of these and other objectives described herein will be met by embodiments of the present invention.

In one embodiment, the present invention provides a method of screen printing hydrophilic coatings for analyte detecting members based on surfactants and hydrophilic polymers. The present invention may use the combination of zwitterionic surfactant and hydrophilic polymer. The sensitivity of the glucose detecting device can be increased by using the using the surfactant with the hydrophilic polymer. In one embodiment, a paste of basic compound and hydrophilic compound is combined with a compound such as but not limited to 3-[(3-cholamidopropyl)-dimethylammonium]-1-propansulfonate (CHAPS) or derivatives thereof, and all are mixed together. A suitable zwitterionic includes but is not limited to CHAPS. To make it screen printable, a non-ionic co-surfactant may be included to achieve stability of the mixture and dispersion. A suitable non-ionic includes but is not limited to alkyl phenols or anionic such as but not limited to, alkylsulphones. Additionally, it should be noted that wicking speed is increased by virtue of the fact that these ionic surfactants are used. In one nonlimiting example, wicking speed is increased by 50% from several seconds down to 1 second.

The present invention may also improve the ratio between maximum current and background current. This ratio can extend the measuring range of the analyte detecting device. This can also improve accuracy. With only diffusion dependent current, the present invention can measure the current with higher accuracy if compared with the kinetic determined current. With the high ratio, the measurement range is in the diffusion range and this avoids measurement with kinetic controls.

With the hydrogels, accuracy can be improved because the maximum current can be increased. The measurement range or glucose concentration range that can be measured is bigger than without the hydrophilic membrane. In some embodiment, the hydrogel may be used to create that membrane. The hydrogel may add stability to the

mediator and may add linear range to the performance of the analyte detecting member. The present invention also provide additives to achieve a printable paste.

In one embodiment of the present invention, a method is provided for manufacturing an analyte detecting device. The method comprises providing a substrate, applying a plurality of layers of materials on the substrate, wherein the layers form an electrode device. A hydrogel may be screen printed on the layers that form the electrode device. A plurality of layers of materials may be applied to form a sample capture device. In some embodiments, the layers may be formed directly over a portion of the hydrogel. The hydrogel may include a zwitterionic compound. The hydrogel may include a zwitterionic compound selected from one of the following: CHAPS or its derivatives. The method may further comprise applying a layer containing at least one mediator, with the hydrogel being formed in contact with the mediator.

In another embodiment of the present invention, a method is provide for manufacturing an analyte detecting device. The method comprises providing a substrate and coating analyte detecting member surfaces/electrodes on said substrate with a cross-linkable hydrophilic polymer dispersion containing at least one of the following: a hydrophilic monomer mixture, a low molecular weight cross-linker and/or a hydrophilic high molecular weight polymer and preferably with an initiator.

In another embodiment of the present invention, a compound is provided for use on an analyte detecting device. The compound comprises a cross-linkable hydrophilic polymer dispersion containing a hydrophilic monomer mixture, a low molecular weight cross-linker and a hydrophilic high molecular weight polymer and preferably with an initiator. The low molecular weight cross-linker and the high molecular weight polymer may be replaced or used in combination with one of the following: a hydrophilic, (partially) vinyl functionalized high molecular weight polymer, a so-called macromer.

The compound may be configured to allow rapid wicking of the analyte solution as well as rapid swelling of the resulting hydrogel membrane to allow a fast diffusion of the analyte to the enzyme. The compound may be configured to achieve highly cross-linked hydrogel to allow the permeation of low molecular weight analytes to the entrapped enzyme. The hydrophilic high molecular weight compound may be homo- or copolymer based on monomers such as but not limited to, N-vinyl pyrrolidone, ethylene oxide, acrylic or methacrylic acid and salts, esters and amides thereof, vinyl alcohol and derivatives thereof and glucose and the derivatives thereof. The hydrophilic high

molecular weight compound may be a macromolecular compound that can be partially vinyl functionalized and will be entrapped in or covalently bond to the formed poly vinyl matrix by thermal- or UV-induced radical polymerization. The macromer may be a di- or polyvinylfunctional macromolecular substance based on di- or polyhydroxy-functionized polymers such as but not limited to, polyvinyl alcohol and derivatives thereof, poly ethylene glycol, polyalkylene oxide, polysaccharides or hydroxy terminated polyurethane's which are as well rheological additive as well as macromolecular cross-linker.

The hydrophilic monomer mixture may further comprise a water-soluble vinyl monomers selected from one of the following: acrylic and methacrylic acid and salts, amides and esters thereof, N-vinyl pyrrolidone and other water-soluble vinyl monomers. The low molecular weight cross-linkers may be di- or polyesters, -ethers or amides of acrylic or methacrylic acid and other radically polymerisable vinyl compounds. It should be understood that the concentration as well as the molecular weight of the cross-linker as described above as well as the degree of vinyl fictionalizations of the macromer as described above determines the porosity of the gel, which allows entrapment or permeation of the biological active species. The compound may contain a thermal or photochemical initiator selected from one of the following: (functionalized) alkylphenones or redox initiators, preferably UV-cleavable initiators.

The compound may contain at least one surfactant, which enhances the wettability of the analyte solution on the surface as well as the swelling of the hydrogel coating in contact with the analyte solution. The surfactants may be at least one of the following non-ionic surfactants such as but not limited to, alkylphenol polyglycol ethers, sorbitan esters, (ethoxylated) alkin dolls (partially) fluorinated nonionic surfactants, anionic surfactants, alkylsulfonates, alkylbenzenesulfonates or (partially) fluorinated surfactants, or zwitter-ionic surfactants, zwitter-ionic cholic acid derivatives or betain sulfates.

The surfactant (mixture) may increase the wettability of the polymer dispersion applied on the more hydrophobic substrate surface by means of (screen-) printing. The polymer dispersion can contain further additives enabling the printability such as but not limited to, defoamers, retarders, pigments, dyes or further rheological additives.

In another embodiment of the present invention, a method is provided for manufacturing an analyte detecting device. The method comprises stencil or screen-

printing a hydrophilic coating that contains at least a hydrophilic polymerbinder, a surface-active compound, and a solvent.

In another embodiment of the present invention, a method is provided for manufacturing an analyte detecting device. The method comprises stencil or screen-
5 printing a hydrophilic coating that contains at least one of a hydrophilic polymerbinder, surface-active compound, defoamer and a solvent.

In another embodiment of the present invention, a method is provided for manufacturing an analyte detecting device. The method comprises stencil or screen-
10 printing a hydrophilic coating that contains at least a hydrophilic polymerbinder, surface-active compound, defoamer, retarder and a solvent.

In another embodiment of the present invention, a device is provided comprising a substrate; at least one electrically conductive lead line formed on the substrate; an insulating layer; a least one working electrode and at least one counterelectrode each formed to contact at least one electrically conductive lead line, wherein an upper portion
15 of the working electrode has a width greater than a lower portion of the electrode; a hydrogel layer formed over the electrode; and a sample capture structure coupled and positioned to deliver fluid to the hydrogel layer. The lower portion may be at least 25% narrower than the upper portion of the electrode. Other embodiments may have a lower portion at least 50% narrower than the upper portion of the electrode. Other
20 embodiments may have a lower portion that is at least 75% narrower than the upper portion of the electrode. The counter electrode may also have an upper portion wider than a lower portion. The hydrogel may include a zwitterionic compound. The zwitterionic compound may be selected from one of the following: CHAPS or its derivatives. The device may include a surfactant. The device may include a mediator.
25 The hydrogel may comprise of a cross-linkable hydrophilic polymer dispersion containing at least one of the following: a hydrophilic monomer mixture, a low molecular weight cross-linker and/or a hydrophilic high molecular weight polymer and preferably with an initiator.

A further understanding of the nature and advantages of the invention will become
30 apparent by reference to the remaining portions of the specification and drawings.

BRIEF DESCRIPTION OF THE DRAWINGS

Figure 1 shows a one embodiment of the present invention.

Figure 2 shows another embodiment of the present invention.

Figure 3 shows a perspective view of one embodiment of the present invention.

Figure 4 shows a cross-sectional view of one portion of the device of Figure 3.

5 Figure 5 is a schematic showing one method of manufacturing according to the present invention.

DESCRIPTION OF THE SPECIFIC EMBODIMENTS

It is to be understood that both the foregoing general description and the following detailed description are exemplary and explanatory only and are not restrictive of the invention, as claimed. It may be noted that, as used in the specification and the appended
10 claims, the singular forms “a”, “an” and “the” include plural referents unless the context clearly dictates otherwise. Thus, for example, reference to “a material” may include mixtures of materials, reference to “a chamber” may include multiple chambers, and the like. References cited herein are hereby incorporated by reference in their entirety, except
15 to the extent that they conflict with teachings explicitly set forth in this specification.

In this specification and in the claims which follow, reference will be made to a number of terms which shall be defined to have the following meanings:

“Optional” or “optionally” means that the subsequently described circumstance may or may not occur, so that the description includes instances where the circumstance
20 occurs and instances where it does not. For example, if a device optionally contains a feature for analyzing a blood sample, this means that the analysis feature may or may not be present, and, thus, the description includes structures wherein a device possesses the analysis feature and structures wherein the analysis feature is not present. Screen-
printable hydrophilic coatings for analyte detecting members based on surfactants and
25 hydrophilic polymers.

In one embodiment of the present invention, a method is provided for covering the reaction zone/the electrode system of an analyte detecting member with a polymeric coating. This may be accomplished by means of screen-printing a layer containing at least one zwitter-ionic surfactant and at least one hydrophilic polymer binder used as the
30 bottom of a hydrophilic sample chamber of a maximum height, which in one embodiment is about 200 μm , consisting of the coating, a spacer forming the sides of the channel and a hydrophilicly coated film forming the top of the channel enabling a rapid wicking speed of the analyte solution, such as but not limited to whole blood, into the sample channel. In

the present embodiment, the polymeric coating covers at least a working electrode containing at least a polymeric electron-conducting material and a mediator. In alternative embodiments, the polymeric coating may contain a biologically active compound.

5 The hydrophilic polymer binder may be a linear, water-soluble homo- or copolymer based on monomers such as but not limited to, N-vinyl pyrrolidone, ethylene oxide, acrylic or methacrylic acid and the salts thereof, preferably acrylic acid and the salts and amides thereof, vinyl alcohol and derivatives thereof, acrylamide and the derivatives thereof and glucose and the derivatives thereof, and N-vinyl pyrrolidone.

10 Referring now to Figure 1, the hydrophilic polymer dispersion may contain a zwitterionic surfactant such as but not limited to, 3-[(3-cholamidopropyl)-dimethylammonium]-1-propansulfonate (CHAPS) or derivatives thereof as shown in formula (I) as main surfactant.

15 In addition to the surfactants mentioned above, the hydrophilic polymer dispersion contains at least one non-ionic co-surfactant such as but not limited to, alkylphenol polyglycol ethers, sorbitan esters, (ethoxylated) alkin diols, (partially) fluorinated nonionic surfactants or anionic surfactants such as but not limited to, alkylsulfonates, alkylbenzenesulfonates or (partially) fluorinated surfactants.

20 The surfactant (mixture) contained in the coating described above enhances the sensitivity and the stability of the analyte detecting member due to its surface active properties increasing the mobility of the embedded mediator.

 The surfactant (mixture) contained in the coating described above may also enhance the wicking speed of the liquid sample into the channel due to the combination of hydrophilic top and bottom of the sample channel.

25 In one embodiment as shown in Figure 2, the mediator may be a lightly subliming electron-transfer mediator embedded in the reaction layer electrode and is a compound represented by the formula (II), wherein the groups R^1 , R^2 , R^3 or R^4 may be the same or different from one another and each one means hydrogen, C^1 - C^{10} alkyl group, preferably a C^1 - C^5 alkyl group, or an aryl group.

30 Referring now to Figure 3, an exploded view of one embodiment of the present invention is shown. This embodiment provides a test strip 50 made of a substrate 100 with a plurality of layers formed thereon. In this embodiment, the printable hydrogel may be a layer 108 that may be formed over the electrodes 140, 142, and 143. In some other

embodiments, the hydrogel may cover only one, any two, or all three or more of the electrodes.

Referring now to analyte detecting members in Figure 4, it should be understood that, although not limited to the following, in this embodiment, the analyte detecting members may be designed as follows. The analyte detecting member may be based on chrono-amperometry measurement technique using glucose oxidase (Gox) enzyme and N,N,N', N'-Tetramethyl-p-phenylenediamine (TMPD), as electron transfer mediator. In one embodiment, the analyte detecting member is a screen-printed three-electrode system. The conducting layers may be made with a commercially available carbon paste. The reference and the counter electrodes 142 and 143 may be made of a commercial formulation of Ag/AgCl. Although not limited to the following, the working electrode 140 may be made from the same commercial carbon paste blended with Gox, the mediator, a buffer and a thinner. The device has optimized the composition of the working electrode material to lower the response time. A phosphate buffer may be used to mitigate pH sensitivity of the mediator.

Additionally, a hydrophilic membrane with a surfactant may be used that stabilizes an otherwise sublimable mediator such as TMPD. This is, presumably, achieved due to low solubility of the mediator in the hydrophilic membrane.

In one embodiment, the device for reading glucose signal is a voltage source providing a constant oxidation potential of 130 mV between the working electrode and the reference electrode. The output signal is the current flow between the working electrode and the counter electrode. The average of eleven successive current readings (measured over 110 milliseconds) after reaching a predetermined equilibrium point is read out. The glucose composition is calculated using one of two calibration lines depending upon the concentration range.

The substrate on which the electrode is formed may be a UV stabilized thick PVC film on which the electrodes, the insulating layer and the active materials may be deposited using screen-printing process. In some embodiments, this PVC layer may be about 750 μm thick. The sample-contacting region on the electrodes is covered with a screen-printed hydrogel ($\sim 4\mu\text{m}$ thick). For the sip-in sensors, the spacer film forms the sidewalls and defines the thickness of the sample region. This may be a double-sided PSA

layer or a screen-printed UV curable adhesive. The cover may be a 127 μm polyester film coated with 8-15 μm hydrophilic coating on the sample-contact side.

Referring still to Figure 4, a cross-section of the analyte detecting members are shown. In this embodiment, a substrate 100 is provided. On top of this substrate, a carbon paste is provided to form conducting layers 102 for a screen-printed three-electrode system. A spacer layer 104 may also be provided. The reference and the counter electrodes 142 and 143 may be made of a formulation of Ag/AgCl. The analyte detecting member may be based on chrono-amperometry measurement technique using glucose oxidase (Gox) enzyme and N,N,N', N'-Tetramethyl-p-phenylenediamine (TMPD), as electron transfer mediator. Although not limited to the following, the working electrode 140 may optionally comprise of carbon paste blended with Gox, the mediator, a buffer and a thinner. A hydrophilic layer or membrane 108 is provided on top of the electrodes. In some embodiments, only the working electrode 140 has the hydrophilic layer 108. It should be understood that the hydrogel may be formed in a variety of shapes including but not limited to rectangular, square, polygonal, circular, triangular, any single or multiple combination of shapes, or the like. As seen in Figure 2, the top layer of the electrode may have a greater width than a lower portion of the electrode which contacts the electrode lead lines 112.

Referring now to Figure 5, one embodiment of a method for manufacturing an analyte detecting member will be described. The method comprises providing a substrate as indicated at step 200 and applying a plurality of layers of materials on the substrate, wherein the layers form an electrode device at step 202. A hydrogel may be screen printed or other applied over or on the layers that form the electrode device at step 204. A plurality of layers of materials may be applied to form a sample capture device at step 206. Some embodiments may only desire one layer to form the sample capture device. By way of example and not limitation, the sample capture device may be capillary channel defined by a cover layer formed over a groove or space. In some embodiments, the layers may be formed directly over a portion of the hydrogel. The hydrogel may include a zwitterionic compound. The hydrogel may include a zwitterionic compound selected from one of the following: CHAPS or its derivatives. The method may further comprise applying a layer containing at least one mediator, with the hydrogel being formed in contact with the mediator.

In another embodiment of the present invention, a method is provide for manufacturing an analyte detecting device. The method comprises providing a substrate and coating analyte detecting member surfaces/electrodes on said substrate with a cross-linkable hydrophilic polymer dispersion containing at least one of the following: a hydrophilic monomer mixture, a low molecular weight cross-linker and/or a hydrophilic high molecular weight polymer and preferably with an initiator.

In another embodiment of the present invention, a compound is provided for use on an analyte detecting device. The compound comprises a cross-linkable hydrophilic polymer dispersion containing a hydrophilic monomer mixture, a low molecular weight cross-linker and a hydrophilic high molecular weight polymer and preferably with an initiator. The low molecular weight cross-linker and the high molecular weight polymer may be replaced or used in combination with one of the following: a hydrophilic, (partially) vinyl functionalized high molecular weight polymer, a so-called macromer.

The compound may be configured to allow rapid wicking of the analyte solution as well as rapid swelling of the resulting hydrogel membrane to allow a fast diffusion of the analyte to the enzyme. The compound may be configured to achieve highly cross-linked hydrogel to allow the permeation of low molecular weight analytes to the entrapped enzyme. The hydrophilic high molecular weight compound may be homo- or copolymer based on monomers such as but not limited to, N-vinyl pyrrolidone, ethylene oxide, acrylic or methacrylic acid and salts, esters and amides thereof, vinyl alcohol and derivatives thereof and glucose and the derivatives thereof. The hydrophilic high molecular weight compound may be a macromolecular compound that can be partially vinyl functionalized and will be entrapped in or covalently bond to the formed poly vinyl matrix by thermal- or UV-induced radical polymerization. The macromer may be a di- or polyvinylfunctional macromolecular substance based on di- or polyhydroxy-functionized polymers such as but not limited to, polyvinyl alcohol and derivatives thereof, poly ethylene glycol, polyalkylene oxide, polysaccharides or hydroxy terminated polyurethane's which are as well rheological additive as well as macromolecular cross-linker.

While the invention has been described and illustrated with reference to certain particular embodiments thereof, those skilled in the art will appreciate that various adaptations, changes, modifications, substitutions, deletions, or additions of procedures and protocols may be made without departing from the spirit and scope of the invention.

For example, with any of the above embodiments, the hydrogel may or may not include the mediator. With any of the above embodiments, the hydrogel may be applied by methods other than screen printing. The embodiments may use deposition techniques.

5 The publications discussed or cited herein are provided solely for their disclosure prior to the filing date of the present application. Nothing herein is to be construed as an admission that the present invention is not entitled to antedate such publication by virtue of prior invention. Further, the dates of publication provided may be different from the actual publication dates which may need to be independently confirmed. All publications mentioned herein are incorporated herein by reference to disclose and describe the
10 structures and/or methods in connection with which the publications are cited. U.S. Provisional Application Ser. No. 60/573,090 (Attorney Docket No. 38187-2729) filed May 20, 2004 is fully incorporated herein by reference for all purposes.

Expected variations or differences in the results are contemplated in accordance with the objects and practices of the present invention. It is intended, therefore, that the
15 invention be defined by the scope of the claims which follow and that such claims be interpreted as broadly as is reasonable.

WHAT IS CLAIMED IS:

- 1 1. A method of manufacturing an analyte detecting device, said
2 method comprising:
3 providing a substrate;
4 applying a plurality of layers of materials on said substrate, wherein said
5 layers form an electrode device; and
6 screen printing a hydrogel on said layers.
- 1 2. The method of claim 1 further comprising applying a plurality of
2 layers of materials to form a sample capture device..
- 1 3. The method of claim 1 wherein said hydrogel includes a
2 zwitterionic compound.
- 1 4. The method of claim 1 wherein said hydrogel includes a
2 zwitterionic compound selected from one of the following: CHAPS or its derivatives.
- 1 5. The method of claim 1 wherein said hydrogel further comprises
2 applying a layer containing at least one mediator, said hydrogel being formed in contact
3 with the mediator.
- 1 6. A method manufacturing an analyte detecting device, said method
2 comprising:
3 providing a substrate;
4 coating analyte detecting member surfaces/electrodes on said substrate
5 with a cross-linkable hydrophilic polymer dispersion containing at least one of the
6 following: a hydrophilic monomer mixture, a low molecular weight cross-linker and/or a
7 hydrophilic high molecular weight polymer and preferably with an initiator.
- 1 7. A compound for use on an analyte detecting device, said
2 compound comprising:
3 a cross-linkable hydrophilic polymer dispersion containing a hydrophilic
4 monomer mixture, a low molecular weight cross-linker and a hydrophilic high molecular
5 weight polymer and preferably with an initiator.

1 8. The compound described in claim 7 wherein the low molecular
2 weight cross-linker and the high molecular weight polymer may be replaced or used in
3 combination with one of the following: a hydrophilic, (partially) vinyl functionalized high
4 molecular weight polymer, a so-called macromer.

1 9. The compound described in claim 7 wherein said compound is
2 configured to allow rapid wicking of the analyte solution as well as rapid swelling of the
3 resulting hydrogel membrane to allow a fast diffusion of the analyte to the enzyme.

1 10. A compound described in claim 6 wherein compound is configured
2 to achieve highly cross-linked hydrogel to allow the permeation of low molecular weight
3 analytes to the entrapped enzyme.

1 11. The hydrophilic high molecular weight compound as described in
2 Claim 6 is homo- or copolymer based on monomers such as but not limited to, N-vinyl
3 pyrrolidone, ethylene oxide, acrylic or methacrylic acid and salts, esters and amides
4 thereof, vinyl alcohol and derivatives thereof and glucose and the derivatives thereof.

1 12. The hydrophilic high molecular weight compound as described in
2 Claim 6 wherein macromolecular compound can be partially vinyl functionalized and will
3 be entrapped in or covalently bond to the formed poly vinyl matrix by thermal- or UV-
4 induced radical polymerization.

1 13. The compound as described in Claim 6 wherein the macromer is a
2 di- or polyvinylfunctional macromolecular substance based on di- or polyhydroxy-
3 functionalized polymers such as but not limited to, polyvinyl alcohol and derivatives
4 thereof, poly ethylene glycol, polyalkylene oxide, polysaccharides or hydroxy terminated
5 polyurethane's which are as well rheological additive as well as macromolecular cross-
6 linker.

1 14. The hydrophilic monomer mixture as described in Claim 6 further
2 comprising water-soluble vinyl monomers selected from one of the following: acrylic and
3 methacrylic acid and salts, amides and esters thereof, N-vinyl pyrrolidone and other
4 water-soluble vinyl monomers.

1 15. The compound as described in as described in Claim 6 wherein the
2 low molecular weight cross-linkers are di- or polyesters, -ethers or -amides of acrylic or
3 methacrylic acid and other radically polymerisable vinyl compounds.

1 16. The compound as described in claim 6 wherein the concentration
2 as well as the molecular weight of the cross-linker as described in Claim 17 as well as the
3 degree of vinyl fictionalizations of the macromer as decried in Claim 14 determines the
4 porosity of the gel, which allows entrapment or permeation of the biological active
5 species.

1 17. The compound as described in claim 6 contains a thermal or
2 photochemical initiator selected from one of the following: (functionalized)
3 alkylphenones or redox initiators, preferably UV-cleavable initiators.

1 18. The compound as described in claim 6 contains at least one
2 surfactant, which enhances the wettability of the analyte solution on the surface as well as
3 the swelling of the hydrogel coating in contact with the analyte solution.

1 19. The compound as described in claim 17 wherein the surfactants
2 are non-ionic surfactants such as but not limited to, alkylphenol polyglycol ethers,
3 sorbitan esters, (ethoxylated) alkin dolls (partially) fluorinated nonionic surfactants,
4 anionic surfactants, alkylsulfonates, alkylbenzenesulfonates or (partially) fluorinated
5 surfactants, or zwitter-ionic surfactants, zwitter-ionic cholic acid derivatives or betain
6 sulfates.

1 20. The compound as described in claim 17 wherein the surfactant
2 (mixture) increases the wettability of the polymer dispersion applied on the more
3 hydrophobic substrate surface by means of (screen-) printing.

1 21. The compound as described in claim 6 wherein the polymer
2 dispersion can contain further additives enabling the printability such as but not limited
3 to, defoamers, retarders, pigments, dyes or further rheological additives.

1 22. A method of manufacturing an analyte detecting device, said
2 method comprising:

3 stencil or screen-printing a hydrophilic coating that contains at least one of
4 the following: a hydrophilic polymerbinder, a surface-active compound, and a solvent.

1 23. A method of manufacturing an analyte detecting device, said
2 method comprising:

3 stencil or screen-printing a hydrophilic coating that contains at least a
4 hydrophilic polymerbinder, surface-active compound, defoamer and a solvent.

1 24. A method of manufacturing an analyte detecting device, said
2 method comprising:

3 stencil or screen-printing a hydrophilic coating that contains at least one of
4 the following: a hydrophilic polymerbinder, surface-active compound, defoamer, retarder
5 and a solvent.

1 25. A device comprising:

2 a substrate;

3 at least one electrically conductive lead line formed on the substrate;

4 an insulating layer;

5 a least one working electrode and at least one counterelectrode each

6 formed to contact at least one electrically conductive lead line, wherein an upper portion
7 of the working electrode has a width greater than a lower portion of the electrode;

8 a hydrogel layer formed over the electrode; and

9 a sample capture structure coupled and positioned to deliver fluid to the
10 hydrogel layer .

1 26. The device of claim 25 wherein the lower portion is at least 25%
2 narrower than the upper portion of the electrode.

1 27. The device of claim 25 wherein the lower portion is at least 50%
2 narrower than the upper portion of the electrode.

1 28. The device of claim 25 wherein the lower portion is at least 75%
2 narrower than the upper portion of the electrode.

1 29. The device of claim 25 wherein the counter electrode also has an
2 upper portion wider than a lower portion.

1 30. The device of claim 25 wherein said hydrogel includes a
2 zwitterionic compound.

1 31. The device of claim 25 wherein said hydrogel includes a
2 zwitterionic compound selected from one of the following: CHAPS or its derivatives.

1 32. The device of claim 25 further comprising a surfactant.

1 33. The device of claim 25 further comprising a mediator.

1 34. The device of claim 25 wherein said hydrogel comprises a cross-
2 linkable hydrophilic polymer dispersion containing at least one of the following: a
3 hydrophilic monomer mixture, a low molecular weight cross-linker and/or a hydrophilic
4 high molecular weight polymer and preferably with an initiator.

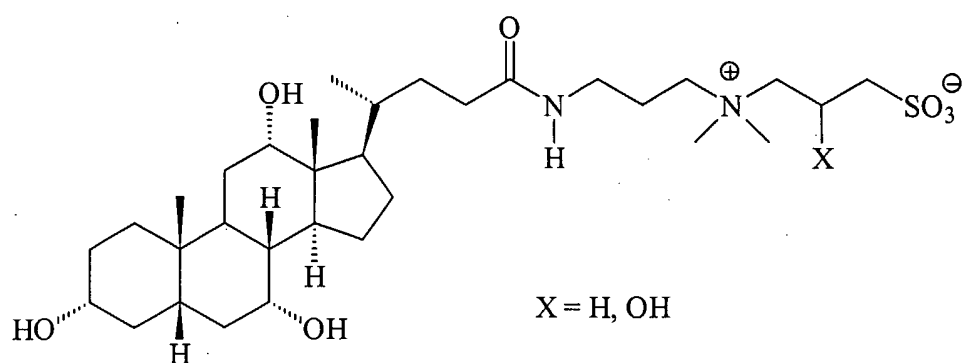

Figure 1

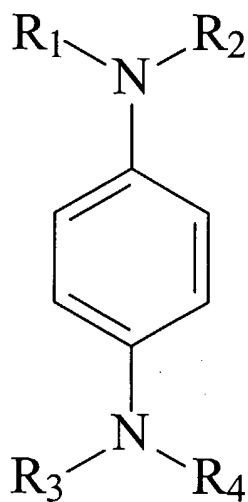

Figure 2

50 →

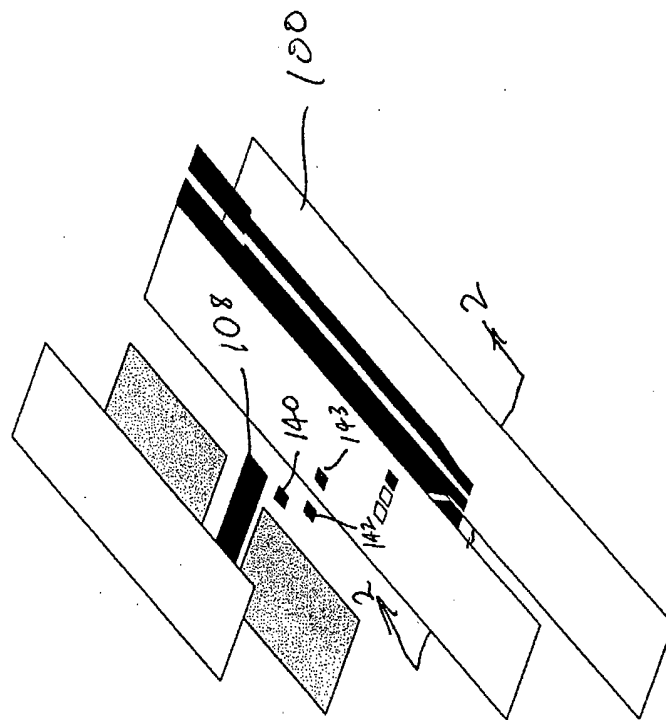

FIG-3

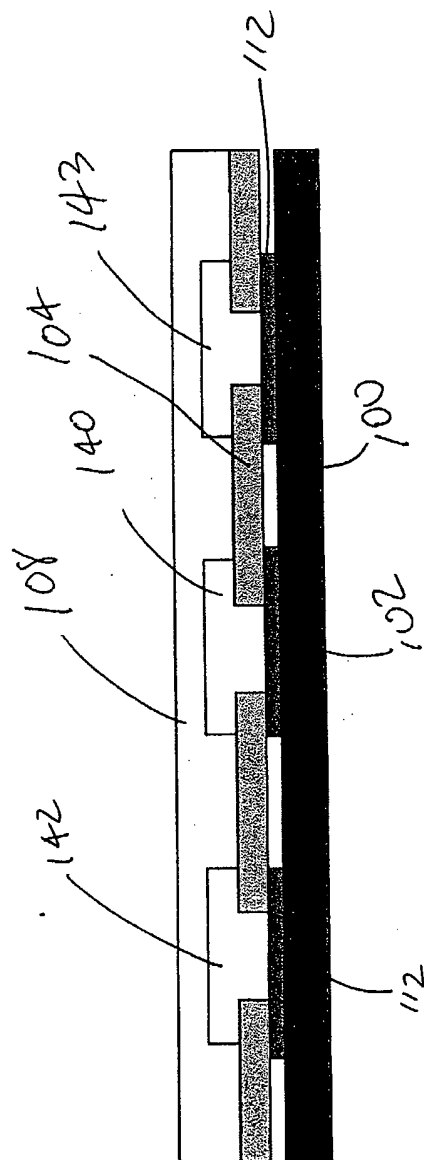

FIG-4

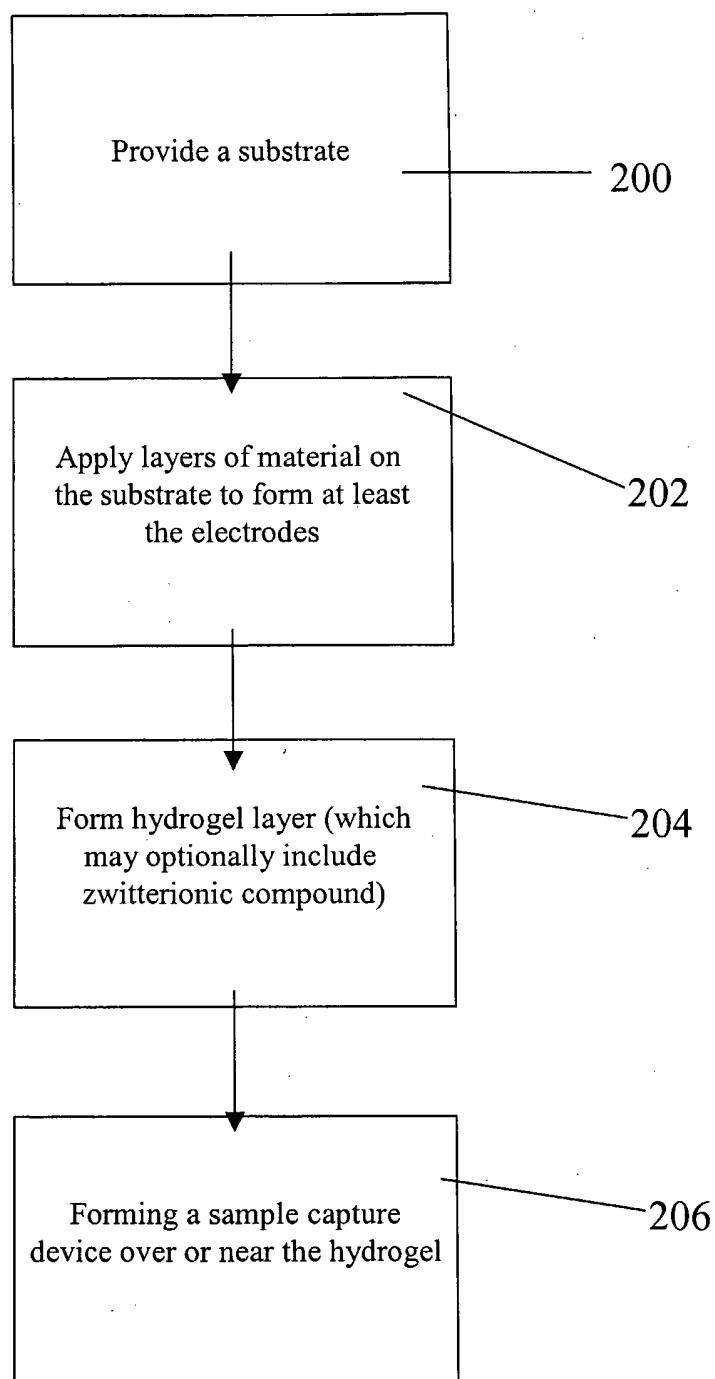

Figure 5