

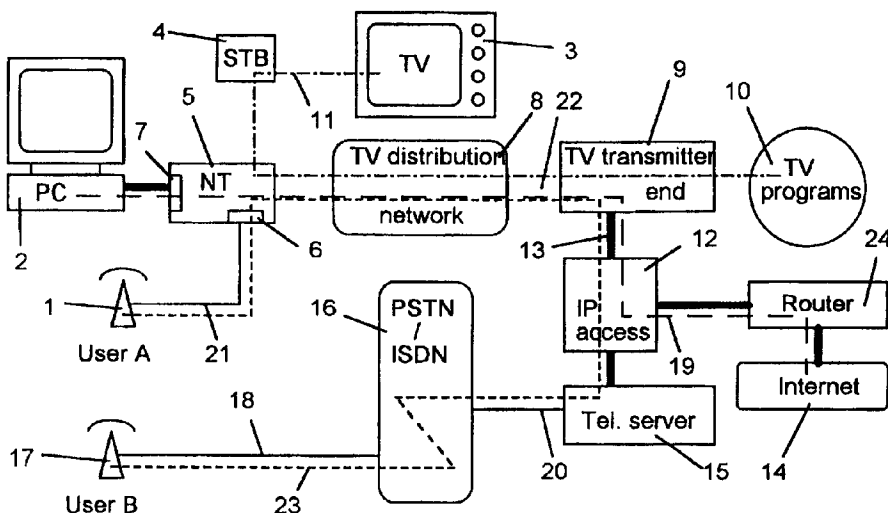

(72) TÖNNBY, Ingmar, SE
(72) HANSSON, Allan, SE
(71) TELEFONAKTIEBOLAGET LM ERICSSON, SE
(51) Int.Cl.⁶ H04L 29/06, H04N 7/10, H04M 11/06
(30) 1996/06/04 (9602212-4) SE
(30) 1996/11/29 (9604409-4) SE
(54) **RESEAU D'ACCES UTILISANT UN MOYEN PARTAGE**
(54) **AN ACCESS NETWORK OVER A SHARED MEDIUM**



(57) L'invention concerne un procédé donnant accès à des sources d'au moins un réseau téléphonique (16) et d'au moins un réseau à protocole Internet (IP) par un réseau de télédistribution (8). Dans ledit procédé, le protocole IP est utilisé comme technique de multiplexage interne et mécanisme de transport. La gestion du protocole IP s'effectue entre un terminal de réseau TV à IP (5), connecté à une extrémité utilisateur du réseau de télédistribution (8), par l'intermédiaire d'un serveur d'accès IP (12), connecté à une extrémité émetteur TV (9) du réseau de télédistribution (8), et, respectivement, à un serveur téléphonique (15) et à un routeur (24). Le procédé et le système selon l'invention permettent un trafic de communication de données et téléphonique dans un terminal de réseau (5), au sein du réseau de télédistribution (8), ou l'accès à des fournisseurs de services de réseaux téléphoniques et à IP (14, 16).

(57) A method for providing access to sources of at least one telephone network (16) and at least one IP based network (14) over a TV distribution network (8). The method uses the IP protocols as an internal multiplexing technique and transport mechanism. The IP handling takes place between a TV IP network terminal (5), connected to a user end of the TV distribution network (8), via an IP access server (12), connected to a TV transmitter end (9) of the TV distribution network (8), to a telephony server (15) and a router (24), respectively. The method and system allows for simultaneous datacom and telephone traffic within one network terminal (5), within the TV distribution network (8), or access to connected service providers of telephone and IP based networks (14, 16).



PCT

WORLD INTELLECTUAL PROPERTY ORGANIZATION
International Bureau

INTERNATIONAL APPLICATION PUBLISHED UNDER THE PATENT COOPERATION TREATY (PCT)

<p>(51) International Patent Classification ⁶ : H04M 3/42, 11/06, H04L 12/66 // H04N 7/00</p>	<p>A1</p>	<p>(11) International Publication Number: WO 97/47119 (43) International Publication Date: 11 December 1997 (11.12.97)</p>
<p>(21) International Application Number: PCT/SE97/00970 (22) International Filing Date: 3 June 1997 (03.06.97) (30) Priority Data: 9602212-4 4 June 1996 (04.06.96) SE 9604409-4 29 November 1996 (29.11.96) SE (71) Applicant (for all designated States except US): TELEFON-AKTIEBOLAGET LM ERICSSON (publ) [SE/SE]; S-126 25 Stockholm (SE). (72) Inventors; and (75) Inventors/Applicants (for US only): TÖNNBY, Ingmar [SE/SE]; Sturegatan 60, S-114 36 Stockholm (SE). HANSSON, Allan [SE/SE]; Åsögatan 129, 4tr, S-116 24 Stockholm (SE). (74) Agents: BJELLMAN, Lennart et al.; Dr Ludwig Brann Patentbyrå AB, P.O. Box 1344, S-751 43 Uppsala (SE).</p>		<p>(81) Designated States: AL, AM, AT, AU, AZ, BA, BB, BG, BR, BY, CA, CH, CN, CU, CZ, DE, DK, EE, ES, FI, GB, GE, GH, HU, IL, IS, JP, KE, KG, KP, KR, KZ, LC, LK, LR, LS, LT, LU, LV, MD, MG, MK, MN, MW, MX, NO, NZ, PL, PT, RO, RU, SD, SE, SG, SI, SK, TJ, TM, TR, TT, UA, UG, US, UZ, VN, YU, ARIPO patent (GH, KE, LS, MW, SD, SZ, UG), Eurasian patent (AM, AZ, BY, KG, KZ, MD, RU, TJ, TM), European patent (AT, BE, CH, DE, DK, ES, FI, FR, GB, GR, IE, IT, LU, MC, NL, PT, SE), OAPI patent (BF, BJ, CF, CG, CI, CM, GA, GN, ML, MR, NE, SN, TD, TG).</p> <p>Published With international search report. Before the expiration of the time limit for amending the claims and to be republished in the event of the receipt of amendments.</p>

(54) Title: AN ACCESS NETWORK OVER A SHARED MEDIUM

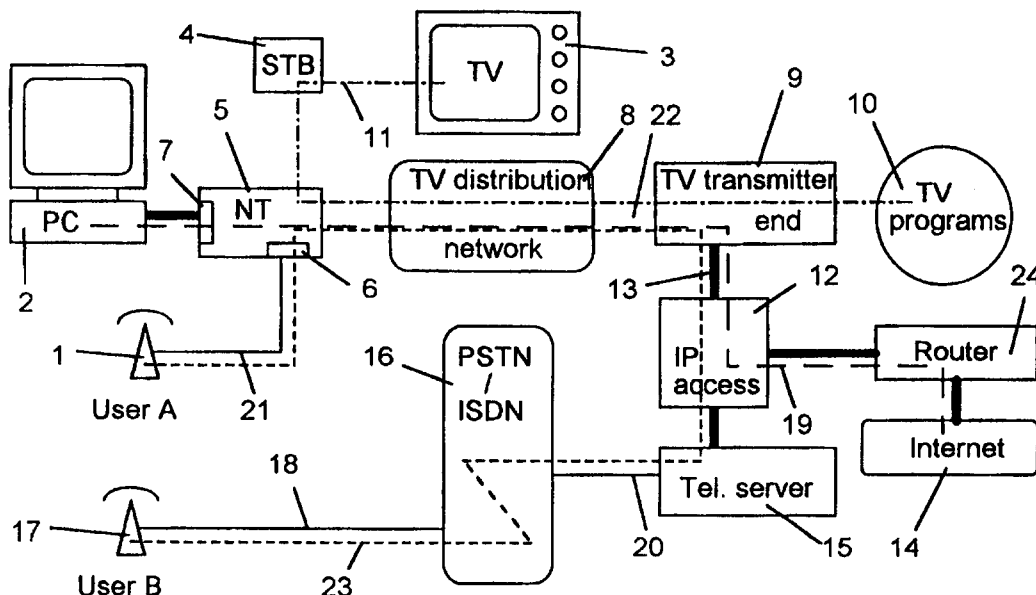

(57) Abstract

A method for providing access to sources of at least one telephone network (16) and at least one IP based network (14) over a TV distribution network (8). The method uses the IP protocols as an internal multiplexing technique and transport mechanism. The IP handling takes place between a TV IP network terminal (5), connected to a user end of the TV distribution network (8), via an IP access server (12), connected to a TV transmitter end (9) of the TV distribution network (8), to a telephony server (15) and a router (24), respectively. The method and system allows for simultaneous datacom and telephone traffic within one network terminal (5), within the TV distribution network (8), or access to connected service providers of telephone and IP based networks (14, 16).

An access network over a shared medium**TECHNICAL FIELD OF THE INVENTION**

The present invention relates to telecommunication in general and to voice and data communication. In particular the invention relates to access to telephony networks and Internet protocol (IP) based networks over a shared physical medium, such as a TV distribution network.

RELATED ART

Traditional cable TV (CATV) networks are analogue and unidirectional networks for distribution of TV programs to many users. This is performed via a branched distribution network comprising cascaded amplifiers. The cable will constitute a shared physical medium, where the headend provides the analogue signals and the user end terminals tap the signals. A single cable TV headend may serve over 100 000 users within a distance of up to 15 km via one single trunk.

Upgraded CATV networks support bi-directional communication, why the amplifiers also have to support bi-directional communication. The cable will then behave like a closed ether, the frequency spectrum of which is available for communication between the head end and the users. The network is normally asymmetric in transfer capabilities, a few Mb/s available in the upstream channels and 10 - 50 Mb/s in the downstream channels, beside a number of TV channels. The number of users is so large that non-compressed voice may only be provided to a small fraction of users.

Hybrid-fibre coax network, where parts of the coax network are replaced by networks with optical fibre, have fewer users, normally a couple of thousand. The available bandwidth is shared by much fewer users and is sufficient to provide two-way communication for all users. An even more upgraded type of network solution is according to the Regional Hub/Passive Coaxial Network Architecture. The fibre node in such a configuration typically serves 200-500 users.

Recently, a rapid development has taken place in order to extend the range of services which can be supported by cable TV network. The main issue is related to support of IP access and telephone access by using two-way channels over a cable TV network. An IEEE group 802.14 is developing a standard for the physical layer and a MAC (Medium Access Control) protocol for CATV networks. It will support both connectionless and connection-oriented services. Stream services, such as constant bit rate (CBR), variable bit rate (VBR) and available bit rate (ABR) will be handled. The network should be used to support unicast, multicast and broadcast services. It will also support ATM (Asynchronous Transfer Mode). Generally, the upstream bandwidth is much lower than the downstream bandwidth.

One example of a possible protocol stack is one using the IEEE protocols, which uses Medium Access Control (MAC) layers, according to IEEE 802.3 and 802.14 (in particular the Draft Supplement to IEEE Std 802.14, 802.14MAC/V1.1, December 31, 1996), above which there is a Logical Link Control (LLC) layer, according to IEEE 802.2, which at the end user and the IP access server supports the Internet Protocol (IP). The IEEE protocols can be part of a solution to provide access to telephony networks, e.g. PSTN (Public Switched Telephone Network). A control protocol, as well as the user data are carried on top of the link layer.

Other telephony access approaches over a CATV network allocate a channel, allowing for a two-way, e.g. 64kb/s, stream for each call. Also such solutions are dependent on the development of control signalling handling solutions.

An interaction channel is provided to digital video broadcasting (DVB) systems based on digital enhanced cordless telecommunications (DECT). An European draft specification of such a system is known in the art, e.g. through "Draft specification of DVB Interaction Channel based on DECT", DVB-RC-165 rev 7, version 4.0, 27 March 1997. In this specification a packet distributing service point-to-point is available together with the DVB. The DECT specification also provides 32 kb/s channels for telephony. In this specification a protocol stack model is presented, which in the

bottom has protocols for modulation, channel coding, frequency range, filtering, equalisation and power. On top of this, protocols for the access mechanism and packet structure is provided, all connected to the actual network. The network independent protocols are then placed on top of this.

5

A new technique that for simultaneously an Internet session and a telephony session over the same telephone access line includes a telephone doubler arrangementphone doubler described in Figure 10 below and in reference [1].

10 The telephone doubler arrangement permits permits a user which is connected to an analogue telephone network to access an IP-based communication service and still be able to receive and answer incoming calls, and to place outgoing calls, while simultaneously surfing the Internet.

15 In Figure 10 the telephone doubler arrangementphone doubler 101 is shown to be connected to PSTN 102 and to Internet 103. At the user side a modem 104 is connected to PSTN 102, to a standard analogue telephone 105 and to a PC 106. The telephone doubler arrangement 101 comprises a modem pool 107 connected to PSTN 102, to Internet 103 and to a telephony server 109. The telephony server 109
20 is connected to PSTN 102.

When a user A is connected to Internet 103 via a dialed up PSTN connection to the modem pool 107 the telephone 105 cannot be used. On his/her PC the user can still communicate with other PSTN users by using the connectivity and multiplexing capabilities of IP. The dialed up line can carry a multiplexed stream of IP packages of:
25 (a) an Internet session and (b) a telephony call. Speech carrying IP packages are routed to/from the telephony server 109 to PSTN. Telephony control signals are exchanged between the telephony server 109 and a telephony application 110 which runs on the PC. If the PC has audio capabilities, symbolized by a headset 111 comprising earphones and a microphone, a user A can be engaged in speech conver-
30

sations with other users connected to the PSTN or ISDN. The user has got a new, soft phone on the PC 106.

Another new technique that allows for simultaneously an Internet session and a telephony session over the same telephone access line includes makes use of the telephone doubler principle described above complemented, at the user end, with an IP modem 112 as shown in Figure 11 and in reference [2]. IP functionality, such as provided by the PC 106 in Figure 10, has been integrated in the modem 112 and therefore the modem is referred to as an IP modem.

10

This arrangement makes possible a dialed up connection, using a standard analog telephone, or a telephony application on a PC, while simultaneously an Internet user is engaged in an Internet session over a PC connected to the same IP modem.

15 The arrangement shown in Figure 11 is similar to that of Figure 10. A telephone doubler arrangement phone doubler 101 is connected to PSTN and Internet and comprises the same units as in Figure 10.

Over a first IP link 113 between the IP modem and Internet 103 IP packets containing information relating to an Internet session are transported. Part of this link comprises a subscriber line 114 extending between the IP modem and PSTN. Over a second IP link 115 IP packets carrying digitized, compressed speech are transported to/from the telephony server and the modem pool. The telephony server creates a dynamic relation between the IP address of the IP modem and the telephone number of user A. Using the call forwarding service in PSTN incoming calls to user A are redirected to the telephony server.

The arrangement will allow user A to take and to place telephone calls using the ordinary telephone while there is an ongoing Internet session on the personal computer. Also a "soft phone" like the one in reference [1] is provided. Since the modem has IP capabilities it will be possible to communicate with other devices, such as

30

additional equipment can be connected to it, such as a private LAN, an electricity consumption meter and similar devices, over a home network.

The IP modem is shown in Figure 12 and comprises a subscriber line interface 116, one or more telephone interfaces 117, 118, at least one PC interface 119 and, optionally, a LAN interface 120. There is also an IP multiplexor/demultiplexor 121 and a controller 122. An optional application 123 can run in the IP modem, such as for example an e-mail poller for polling electronic mail-boxes of user A. The IP multiplexor/demultiplexor routes IP packets from the subscriber line interface to their destinations; the PC, the telephone or the LAN. The controller provides control over the functionalities of the IP modem.

References [1] and [2] both provide telephony access and IP traffic can be superimposed the telephony access. However, both solutions are limited to one service provider of telephone networks or IP based networks. The solutions are also limited to a PSTN network as access network.

SUMMARY OF THE INVENTION

One object of the present invention is to provide access to services of at least one telephony network and at least one IP based network over a TV distribution network, a shared medium, which is enhanced to provide logical two-way links.

Another object of the present invention is to provide simultaneous telephony and IP access and to provide more than one simultaneous telephony connection to one particular customer.

Still another object of the present invention is to allow different users of the same network or a single user to relate to different service providers of the same service, e.g. telephony or Internet.

Internal calls between different telephony devices of the same network terminal or connected to the same TV distribution network are also to be supported.

The above objects are provided by a method and devices according to the present invention as it is defined in the enclosed claims.

According to the invention a method is provided, which provides access to at least one telephony network, using a TV distribution network with an interaction channel, supporting bi-directional communication, as a transmission medium simultaneously to TV broadcasting. The method uses IP as an internal multiplexing technique.

Moreover, according to the invention a TV Internet Protocol Network Terminal, hereafter called "NT", which functions as an end user network terminal, i.e. a receiver end, of the TV distribution network, is provided with interfaces for different terminal units, e.g. telephony interfaces and computer or LAN interfaces. The LAN/PC interface supports exchange of IP packets and the telephony interfaces are enhanced with capabilities to detect control signals from the phone and to generate control signals to the phone as well as to digitise speech and decode digital information into speech. The NT also contains functionality to support services, e.g. telephony. It also provides communication with external applications.

The invention also provides a telephony server, which has connections to at least one telephony network and which comprises means for associating a certain telephone number with a certain NT and means assisting in using IP as a multiplexing technique. The telephony server also provides functionality to support telephony, and comprises means to interface one or more telephony networks.

Similarly, the invention also provides a router, which has access to at least one IP based network and which comprises means for associating a certain external IP address with a certain NT and means assisting in using IP as a multiplexing technique.

BRIEF DESCRIPTION OF THE DRAWINGS

The invention and its merits will be described in connection with the accompanying drawings, in which

- 5 Fig. 1 is a block diagram of entities involved in the access handling via a TV distribution network in accordance with the invention,
- Fig. 2 is a functional block diagram of the network terminal in accordance with the invention,
- 10 Fig. 3a is a block diagram of an example of a part of a protocol stack, which may be used for the external port in the NT in accordance with the invention,
- Fig. 3b is a block diagram illustrating how the access network handles the telephony application,
- 15 Fig. 3c is a block diagram illustrating how the access network handles the IP application,
- 20 Fig. 4 is a block diagram of entities involved in the access handling via a TV distribution network in accordance with the invention, with two telephones connected to the same NT.
- Fig. 5 is a block diagram of entities involved in the telephony access handling via a TV distribution network in accordance with the invention, illustrating telephone communication between a telephony application at a computer and a normal telephone.
- 25 Fig. 6 is a block diagram of entities involved in the telephony access handling via a TV distribution network in accordance with the invention, illustrating tele-
- 30

phone communication between a telephone and a telephony application at a computer via Internet.

5 Fig. 7 is a block diagram of entities involved in the access handling via a TV distribution network in accordance with the invention, where several service providers are present,

10 Fig. 8 is a block diagram of entities involved in the telephony access handling via a TV distribution network in accordance with the invention, illustrating internal communication between two telephones or between a telephone and a telephony application on a computer, connected to the same NT,

15 Fig. 9 is a block diagram of entities involved in the telephony access handling via a TV distribution network in accordance with the invention, illustrating internal communication between two telephones connected to the same TV distribution network,

20 Fig. 10 shows a block diagram of a related art "phone doubler" technique, as presented in reference [1],

Fig. 11 shows a block diagram of a related art "IP modem" technique, as presented in reference [2], and

25 Fig. 12 shows the functional blocks of the IP modem, shown in Figure 11.

DETAILED DESCRIPTION OF EMBODIMENTS

In Fig. 1 a user A has a telephone 1, a personal computer 2 and a television set 3. The television set 3 is connected via a set top box (STB) 4 to a NT 5 in accordance with the invention. The NT 5 includes a telephony interface 6 and a computer interface 7, by which the telephone 1 and the personal computer 2, respectively, are
30 connected. The NT 5 constitutes the user end terminal, i.e. a TV receiver end, of a

TV distribution network 8. It communicates with a TV transmitter end 9 via the TV distribution network 8.

The TV transmitter end 9 is conventionally supplied with TV programs from various sources, one of which is shown at 10. The TV programs 10 are distributed from the TV transmitter end 9 to the different end users via the TV distribution network 8 according to conventional methods. The NT 5 is transparent regarding the frequency channels used for the TV broadcasting and these frequencies are passed unaltered to the STB 4, which carries out the conventional procedures for supplying the TV programs to the TV set 3. The information flow for the TV broadcasting is indicated by the dashdot line 11 in Fig. 1.

The distribution of TV programs is not affected by the use of the present invention, and this will therefore not be discussed in full detail. The only feature request of the TV distribution network 8 is that it supplies a link service, which receives IP-packets and delivers them safely to the intended destination point. For example, in a conventional CATV network, the TV transmitter end 9 is e.g. constituted by a CATV headend. The TV transmitter end 9 is thus only characterised by being a point in the network which is common for a suitable set of users. In more sophisticated CATV network configurations, see e.g. Draft Supplement to IEEE 802.14, "Physical layer Specification for HFC CATV Networks", 802.14PHYV.1.0, Febr. 7, 1997, fibre hubs, regional hubs etc. may thus be the TV transmitter end 9 of the present invention.

An attractive scheme for providing an interaction channel in a TV distribution network 8 is presented by "Draft specification of DVB Interaction Channel based on DECT", DVB-RC-165 rev 7, vers. 4.0, march 27, 1997. In this scheme two channels are established between the service provider and the user. A unidirectional broadband broadcast channel including video, audio and data corresponds to the conventional cable TV service. A bi-directional interaction channel is also established between the service provider and the user for interaction purposes and is formed by a forward interaction path and a return interaction path.

The TV transmitter end 9 is also permanently connected to an IP access server 12 via e.g. a LAN 13 with a link protocol. The IP access server 12 is connected to a router 24 and a telephony server 15. The router 24 has in a conventional manner access to Internet 14. The telephony server 15 is in turn connected to PSTN 16 and provides the telephony service to users of the TV distribution network 8. Another user B 17 has a telephone connected to the PSTN 16 via a subscriber line 18.

The IEEE set of LAN related protocols gives an opportunity to extend the link service between the NT:s 5 and the IP access server 12. By the means of a bridging protocol 42 (fig. 3a) according to IEEE 802.1, the link protocol, e.g. LLC 41 (fig.3a) can operate over different domains with different physical and MAC protocols, e.g. the cable TV MAC protocol according to IEEE 802.14 between an NT 5 and a TV transmitter end 9 and Ethernet (IEEE 802.3) between the TV transmitter end 9 and the IP access server 12. This means that the bridging protocol 42 (fig. 3a) takes care of the task of changing medium during the transmission of packets from/to the IP access server 12 to/from the right NT 5.

Fig. 3a shows an example of a part of a possible protocol stack of the external port in the NT 5. The external coaxial port stack has the Analogue bearer 45 as the lowest protocol layer. On top of this, a Physical layer 44 and above that a Medium Access Control layer 43, and a bridging protocol 42. On top of the bridging layer is a LLC layer 41, and on top of that an IP layer 40 which transmits packets between the NT 5 and the IP access server 12 ports. The service of the LLC 41 is to transfer packets point to point between NT's 5 and the IP access server 12.

The telephony server 15 comprises a telephony application 50a (Fig. 3b). This telephony application 50a is intended to communicate with a telephony application 50c (Fig. 3b) in the NT 5 and create a relation (call) between instances in both entities, i.e. the telephony applications 50a, 50c handle the relations between telephone numbers or equivalent and local addresses and port numbers for the telephony ap-

plications. The telephony applications 50a, 50c also handle the telephony signalling, i.e. handle the service specific protocols, e.g. control protocols for telephony.

More in detail, figure 3b illustrates how the access network handles the telephony application. The basic principle is that the internal communication, to/from the telephony server 15 from/to the NT 5, is performed by IP. Accordingly, the system provides an IP domain 40, in which several units communicate by IP. It may also be noted that the entire communication takes place on a level above the TV transmitter end 9.

A telephony application 50a in the telephony server 15 communicates with a telephony service network (not shown). This is preferably done using conventional protocols for control signalling 53a (e.g. V5.2) and speech transferring 52a. The telephony application 50a in the telephony server 15 also communicates with a telephony application 50c in the NT:s 5 by an internal application specific protocol, which e.g. can be V5.2 or another protocol for telephony. In this communication, speech is controlled by a speech handling protocol 52b, 52c and a UDP (User Datagram Protocol) 54b, 54c in both the telephony server 15 and the NT:s 5 and the resulting packages are communicated by the IP domain 40. In parallel, control signalling is handled by a control protocol 53b, 53c and a TDP (Transmission Control Protocol) 55b, 55c above the IP communication layer 40.

The telephony application 50c in the NT 5 is in its turn communicating with a connected telephone 1 and users using them, using an analogue traditional protocol for telephony 51, via e.g. an analogue telephone interface. Also here speech and control signalling are separated, the speech using a UDP 54d and a CODEC 56, while the control signalling is using a TCP 55d and control protocol 53d. There are also possibilities to handle the communication between the telephone application 50c and the respective interfaces in NT:s 5 in other ways than with IP 40, but IP 40 is presently considered as the most preferable solution.

The IP router 24 (Fig. 1) comprises an IP application. This IP application is intended to handle the relations between external IP addresses or equivalent and local addresses and port numbers for the IP applications.

5 Fig. 3c illustrates how the access network works with the IP application 60a, 60b. In this example, the address mapping between external and internal addresses (described further below) in the case of IP communication can be solved by e.g. using tunnelling, which by itself is known in the art. There are several known tunnelling protocols 61a, 61b, and the procedure to establish a tunnel between the router 24
10 and the PC 2 and will therefore not be further described in detail. In this case, however, a tunnel is a mechanism to convey IP packets between two points by means of IP as a transport protocol 40. IP packets are thus conveyed as data in other IP packets. The address spaces are different between the two layers of IP. Generally, the lower IP layer 40 is associated with internal IP addresses, while the upper IP
15 layer 60a, 60b is associated with external IP addresses. In cases where the communication is to be terminated in the NT 5, there are also (not shown) corresponding tunnelling protocols and IP available. This may be useful, for instance, when a user via an analogue telephone wants to have access to the Internet phone capabilities.

20 Address mapping and routing

Address mapping plays an important role in the present invention. The arrangement with several different service providers of each type of service network give rise to several address spaces, which therefore are not possible to use as internal addresses.

25

An IP address is a reference to an interface and a port behind that interface. Usually, a port designates an application.

A network terminal 5 has an internal IP address (internal refers to the access network, i.e. the IP address is not known outside of the access network). Further, a
30 number of ports, each one attached to an application (residing in the NT), which can

be reached over IP, are defined for an NT 5. E.g., the telephony application 50c is addressed by the IP address of the NT 5, and a unique port number. The different accesses, which supports a single device (e.g. a serial port or an analogue telephone access) are seen as applications, and are thus addressed by port numbers.

5 Devices connected to a LAN have their own internal IP address. If they want to communicate over an external IP network 14, they have to have an external IP address as well.

A telephony number, which is associated to a subscription of a telephony service, is
10 associated to one or more devices (attached to an NT 5) with capabilities to handle telephony. Such devices can be e.g. analogue or digital telephones.

Within the access network, e.g. in case of an incoming call to this destination, it is sufficient to be able to address the NT 5 and the telephone application 50c. This is
15 done by mapping the external telephone number (or a representation of it) on the internal address of the NT 5, and the port number of the telephony application 50c. By information carried over the application protocol, the telephony application 50c knows the destination of the call. The telephony application 50c holds information of which telephone interfaces are involved in the destination.

20

The telephony application 50c in an NT 5 communicates with the telephony application 50a in the telephony server 15, which has a similar address (IP address of the telephony server 15 including a port address. The telephony application 50a in the telephony server can in its turn address the proper interface of a wanted telephony
25 network 16.

In case of communication with an external IP network 14, a tunnelling technique can be used. There are several ways to handle this. We assume that the tunnel extends between the PC 2 and the router 24, which handles the interfaces to the external
30 networks 14. All packets travelling a tunnel towards the router 24 are destined to

the same external IP network 14. A PC 2 has an internal IP address and an external IP address.

In that case, an IP packet, which arrives to the router 24 from an external IP network 14, and which is addressed to an application on the PC 2 (by an external IP address with a port number), is handled in the following way. The external IP address is mapped on the internal IP address of the PC 2, including a port number referring to an application which handles the tunnelling protocol. The IP packet is then put in a new IP envelope with the internal IP address, and routed over the access network to the destination PC 2.

An IP packet, which is sent from a PC 2 to an external address, is tunnelled in the same way by an internal IP address, which points out an application handling the tunnelling protocols. The tunnel identity points out which interface the packet is aimed for.

Before the NT 5 is used for traffic purposes it has to be configured, e.g. in order to support the address mapping. The NT is supplied with an internal address of the router 24 and/or telephony server 15 and with data related to the requested use of the access possibilities, i.e. the NT configuration. Such configuration possibilities are discussed further below. When the NT 5 subsequently is installed in the TV distribution network 8, the router 24 and the telephony server 15 has to be informed. Accordingly, the telephony server 15 is informed about its existence and associated internal IP addresses, the port number of the telephony application of the NT 5 and the corresponding telephone number or numbers or equivalent, e.g. port number in the telephony server. Similarly, the router 24 is informed about the internal IP address and the port number of the IP application of the NT 5 and the corresponding external IP address or addresses. In cases where tunnelling protocols are used, the internal address of the PC has to be known. The NT 5 has to be configured accordingly. E.g., a telephone number is related to a number of interfaces.

IP-session

Data communication with an IP network is always possible through the TV distribution network 8. The NT 5 sends IP formatted data in the upstream channel of the TV distribution network 8 to the IP access server 12, which directs the data to the router 24, which in turn distributes the data towards the intended IP network, in this embodiment at Internet 14. The router 24 and IP access server 12 also direct data addressed to the IP address of the NT 5 in the downstream channel of the TV distribution network 8 to the NT 5 and from there to the intended terminal. Thus, the Internet traffic follows the path indicated by a dashed line 19 in Fig. 1.

Incoming call

An incoming call will be handled as follows. User B 17 wants to speak with user A 1 over the telephone and dials the telephone number to user A. The telephony application of the telephony server 15 receives the incoming call. The telephony application in the telephony server 15 creates a message about the incoming call. This message is supplied with the internal IP address of the NT 5, using the previously created relation between the destination telephone number of the incoming call and the internal IP address, and distributed to the IP access server 12. The IP access server 12 uses the link protocol in order to deliver it to the proper NT 5. The NT 5 receives the data packets and deliver it to the telephony application of the NT 5, which associates the information about the intended receiver telephone number with a certain interface 6 (or several). The message about the incoming call is interpreted and user A is finally noticed about the incoming call by a conventional ring signal on a phone initiated from the NT 5.

If user A does not answer the call, the telephony server 15 signals this to the PSTN 16 and the call is rejected, if the caller has not given up before, and the PSTN has not already rejected the call.

If user A answers the call by lifting the receiver at the telephone unit, the NT 5 detects the off hook operation and sends back a message to the telephony server 15, via the TV distribution network 8 and the IP access server 12, for establishing the connection towards the calling user B. In this case, the upstream communication channels in the TV distribution network 8 are used. The telephony server 15 forwards the answer message to PSTN 16. When the call is completed, the telephony server 15 digitises, compresses and packetizes B's speech and sends it over the TV distribution network 8 using the IP protocol. The NT 5 depacketizes the packages, decompresses the information and transforms the digital information into speech again, which is sent to the telephone 1 via the telephony interface 6 and an ordinary telephone line 21. This information flow is described in detail below. Speech originating from the user A is in a similar way digitised, compressed and packetized in the NT 5 and is sent over the TV distribution network 8 to the telephony server 15. The telephony server 15 recovers the speech and sends it to user B 17 over the ordinary PSTN network 16. This is also described in detail below.

The information flow from user B to user A is as follows: From user B, the speech is sent via the PSTN network 16, using any of the conventional transmission techniques, to the telephony server 15. This is indicated by full lines 18, 20 in Fig. 1. Here the speech is digitised and packetized. The telephony server 15 formats the data packages according to the IP protocol and provides the packets with an address to the NT internal IP address using the previously stored relation between A's telephone number and A's IP address. The information here passes as data packets on a link 13, indicated as heavy lines in Fig. 1. The TV transmitter end 9 sends the data packages over its downstream information channels to the requested TV receiver end, i.e. the requested NT 5. Here, the information travels over the TV distribution network 8, in this example comprising DECT, indicated by a shadow line 22 in Fig. 1. The NT 5 receives the data packages, unpacks them and sends them to the appropriate telephony interface 6. Here the digital information is decoded into speech information and sent to the telephone as normal speech on a line, indicated

by a full line 21 in Fig. 1. The information flow from user B to user A is indicated by the dotted line 23 in Fig. 1.

The information flow from user A to user B is as follows. From user A, the speech is sent via a line 21 to the telephony interface 6 on the NT 5, indicated by a full line in Fig. 1. Here the speech is digitised and packetized. The NT 5 formats the data packages according to the IP protocol, providing the data packets with an address corresponding to the telephony server 12 internal IP address. The data packages are sent via the upstream information channels of the TV distribution network 8 to the TV transmitter end 9, c.f. the shadowed line 22 in Fig. 1. Here, the content in the upstream information channels is forwarded to the IP access server 12, where the IP address of the telephony server 15 is detected and subsequently, the data packages are forwarded to the telephony server 15, c.f. the heavy lines 13 in Fig. 1. The telephony server 15 receives the data packages, unpacks them, decode the data into speech, which is sent to the appropriate telephony port and via the PSTN network 16 to user B 17.

When the conversation between user A and user B is finished and A puts the receiver on hook, the NT 5 detects the on hook condition of the telephone of user A. This on hook condition is forwarded via the TV distribution network 8 to the telephony server 15, which terminates the connection to user B. Also, if user B terminates the call, the telephony server 15 forwards the on hook condition over the TV distribution network 8 to the NT 5, and the call is terminated.

25 Outgoing call

An outgoing call will be handled in a similar way. User A wants to speak with user B over the telephone and lifts the receiver. The NT 5 detects the off hook condition and gives a dialling tone to the user A telephone. User A dials the telephone number to user B. The NT 5 detects the number sequence dialled by user A and sends it to the telephony server 15 via the TV distribution network 8 and the IP access server 12. The telephony server 15 places an outgoing call to the requested number

on the PSTN network 16, and sends back a confirmation message to the NT 5, which, in turn, supplies a ring tone to the telephone of user A.

If user B answers the call, a connection between the telephony server 15 and user B is established over the PSTN network 16 in a conventional manner. A message about the connection is sent by the telephony server 15 to the NT 5, the ring tone is interrupted and the full connection is established.

If user B does not answer, user A will place the receiver on hook. The NT 5 detects the on hook condition and sends a message to the telephony server 15 to interrupt the call over the PSTN network 16.

The network terminal

In the following the NT 5 functionality will be described in connection with Fig. 2.

First of all, there is an overall control functionality 30 for controlling the operation of the various functionalities of the NT 5. The NT 5 further comprises at least one LAN/PC interface 31, an IP MUX/DEMUX section 32, at least one device feature section 33, at least one telephone interface 34, a digital stream service 35 and a TV interface 36.

The Digital Stream Service (DSS) 35 uses the transmission capabilities of the TV distribution network 8 (fig.1) to provide a two-way digital transport capability. It uses a link protocol, including a medium access protocol, which takes care of the segmentation of information and delivery to the intended destination point. Such DSS 35 may e.g. work according to the DVB interaction channel based on DECT ("Draft specification of DVB Interaction Channel based on DECT", DVB-RC-165 rev 7, vers. 4.0, march 27, 1997) or the specification of the IEEE 802.2 logical link over IEEE 802.14 MAC protocol for HFC CATV networks.

The LAN/PC interface 31 supports exchange of IP packets. It comprises a LAN or PC interface providing a serial interface supporting IP and PPP protocol layers.

Other interfaces supporting IP is also possible, such as LAN interfaces or the universal serial bus ("Universal Serial Bus Specification Revision 1.0", available at <http://teleport.com/~USB>).

- 5 The telephone interface 34 can be an ordinary analogue interface, with capabilities to detect control signals from the telephone, such as off hook, on hook, hook flash, DTMF (Dual Tone Multi Frequency) signals etc. It may also be a digital interface, wired or wireless, supporting corresponding signals. The telephone interface 34 also generates ringing and acoustic signals, e.g. dial tone. Furthermore, it also converts
- 10 the analogue speech stream into a digital stream (which may be compressed, e.g. by GSM (General System for Mobile communication) standard or DECT), and puts it in IP packets of proper size. Incoming IP packets, which carries speech, are processed the reverse way, i.e. are decoded from a digital stream into analogue speech.
- 15 The IP MUX/DEMUX 32 takes packets from the digital stream service and delivers them to their respective interfaces (demultiplexing). It also multiplex together the IP packets from the different interfaces and sends them multiplexed to the Digital Stream Service 35.
- 20 The TV interface 36 is a conventional interface for the TV distribution network 8 (Fig. 1) and is not further discussed. It is assumed that the TV channels passes the NT 5 but that it may insert or extract TV channels.

Other important features

- 25 Above, the invention is discussed only regarding ordinary phone calls. However, there are other useful features of the invention. One such useful feature is the possibility of simultaneous IP sessions and telephone calls over the same NT 5. A communication capability is always available between the IP access server 12 and the PC 2. The telephony procedure uses the same communication medium as the IP
- 30 session, the telephony data packages are certainly mixed with the datacom traffic, but the telephone call will not influence the session. In other words, a user of Inter-

net does not have to interrupt his session to make a phone call or to receive a call from outside.

Another advantage of the telephony access according to the present invention is illustrated by Fig. 4. In this figure, user A has two telephones connected to the NT 5. The two phones, designated 1a and 1b, are connected to a respective telephone interface 6, as shown in Fig. 1. The two phones may be associated with different phone numbers, but also with the same number. When the NT 5 is configured it has to be decided which relations should be available within the NT 5.

If the phones are associated with different numbers, the procedure is very similar to the above described incoming call. A call to the first telephone number will be directed to the phone 1a and a call to the second telephone number will be directed to the phone 1b. The NT 5 thus enables a multi-access possibility. Although only two telephones of user A is shown in the figure it will be understood that any number of telephones may be connected in this manner.

If the different telephones are associated with the same telephone number, the following situation is one of the possible solutions. When a first call is initiated from an external user, such as user B, a ringing may be initiated on both telephones. When someone answers the call at one of the phones, the call is connected to that particular phone, and the ringing on the other phone is stopped. If a second call to the same phone number is initiated from another external user, one phone is occupied but the other one is free and the new call is alerted at the non-occupied telephone. The NT 5 may therefore direct the new call to the second, non-occupied phone, using a second, non-occupied telephone interface 6.

By configuring the NT 5 in a slightly different way other situations are possible. It is for instance possible to configure the NT 5 in such a way that the NT 5 detects from which number the call origins and dependent on this, call signals are sent to either or both of the telephones 1a, 1b.

In the same way, it is possible to make an outgoing call even if another telephone conversation is going on on one of the phones. The second, non-occupied telephony interface will assist in establishing the contact to the PSTN network 16. Although only two telephones of user A is shown in the figure it will be understood that any number of telephones may be connected in this manner.

Similarly, one telephone connected to the NT 5 may be associated with more than one external telephone number. This means that e.g. if one telephone number is requested the first telephone is addressed, if another telephone number is requested both telephones may be addressed. It is in this way possible to configure the functionality of the NT 5 with any combination of addresses.

In the description of the telephony access, analogue telephones have been assumed. Digital phones will of course work equally well. The NT 5 will then have an interface 6 for a digital telephone. The NT 5 then supports control signals, ringing signals and acoustic signals, but is transferring both these signals and the speech in digital form to the telephone.

The PC 2 may also have a telephony application 25, as indicated in Fig. 5. The PC 2 is then normally equipped with sound capabilities with associated audio devices. The telephony application 25 comprises software running on the PC 2 which allows bi-directional speech communication over the sound capability and the audio devices. The sound capability converts the speech to digitised and compressed audio signals, which are packetized into IP packets. These packets are handled in the same manner as the IP packets from the telephony interfaces, although in this case the PC interface 7 is used. In this manner the telephony application 25 offers the same alternatives as an ordinary telephone. For outgoing Internet calls, the telephony application of the NT 5 is not involved at all. For incoming calls, the configuration of the NT 5 may decide whether alerting of the telephones and a telephony ap-

plication 25 on a PC 2 should be provided or not as in the previously described cases.

In known art Internet connections, the Internet Phone service offered to the users normally requires that both the caller and the receiver are connected to Internet and furthermore that they both have a telephony application 25 running in their computers. Since the speech information according to the present invention is packetized in IP packages during the transmission on the TV distribution network 8 and Internet 14 lines, there is also a possibility for a communication between an ordinary telephone and the Internet Phone service. One possibility is described above, where the Internet 14 user is connected to the TV distribution network 8.

It is also possible for a user of a TV distribution network 8 to use an ordinary telephone to reach another Internet 14 user over the Internet Phone service. When placing the call, the caller informs the NT 5 about the requested IP address instead of the PSTN 16 telephone number, e.g. by selecting an address from a list. Such a situation is sketched in Fig. 6. Note that the PC 2a of user A may not even be turned on.

The above described multi-addressing possibilities are in a similar way present also for the pure datacom access. One PC 2 may be assigned to one IP address, while another PC 2 may have another IP address, which may belong to another Internet 14 service provider.

Today, several service providers of the same service are often available, e.g. different telephone companies. The present invention offers a possibility for the user to select among different service providers. One way to provide this possibility is to have the telephony server connected to each service provider, as shown in Fig. 7.

Above, the service supplier selection was made at the configuration of the NT 5 and is valid for all calls from a certain user. A change of supplier would involve a re-

configuration of the NT 5. However, it is also possible to make the selection for each separate call. The user will then have to provide the information representing the desired service provider, e.g. a code or prefix. Such information is easily integrated, for instance in the requested telephone number. Other possibilities for selecting service suppliers are to include at least a part of the selection procedure in the NT 5. The selection may then be performed automatically and the service provider can be selected based on e.g. the time of the day, the day in the week, etc.

Besides the access to the public telephone network there are other possibilities of voice communication. An internal voice communication channel between the PC 2, using a telephony application 25 or similar software, and an ordinary telephone 1, connected to the same NT 5. If a call is requested from an ordinary telephone, where the receiver is the telephony application 25 of the PC 2, the NT 5 may connect the phone and the telephony application 25 of the PC 2. This use of the NT 5 is illustrated in Fig. 8, where a broken line designate the connection between the computer 2 and the phone 1a.

A generalisation of this, connecting two analogue phones 1a, 1b connected to two telephony interfaces 6 on the same NT 5, is also possible, as is shown in Fig. 8 as a dotted line. This opens the possibility to use the NT 5 as a service node for a local internal phone network, e.g. between different rooms in the same building.

The above described internal network configuration is also possible using datacom. Different computers 2 connected to the same NT 5 may communicate directly without using the TV distribution network 8. The NT 5 will in such a case serve as an intranet server.

Fig. 9 shows another possibility of communication within the same TV distribution network 8. A user A wants to make a request for a call to user B within the same TV distribution network 8. The destination of the call is the ordinary telephone number of user B. When the request of establishing a connection with user B reaches the

telephony server 15, the telephony server 15 recognises the telephone number as one of the users in the TV distribution network 8. The call is then forwarded direct to the right end user without passing the public PSTN network 16. Such services may therefore supply a regional telephone network with the same extent as the TV distribution network 8.

Also in this context, the above ideas of intra-network communication apply to data-com. In such a case, the router 24 will recognise the external IP address as one that is connected to the same TV distribution network 8 and thus forward the datacom traffic directly to the receiver without passing any regular IP based network 14.

The TV distribution network 8 is used as a distribution medium, without influencing the TV broadcasting. However, there are some advantageous possibilities to use the TV programs themselves as well the available hardware. A TV channel that is broadcasted over the TV distribution network 8 passes normally right through the NT 5 to be presented at the TV set 3. However, as mentioned briefly earlier, it would be possible to tap a TV channel and send the information e.g. to the PC 2 or other device with capabilities for visual presentation.

In a similar way information from e.g. the PC 2 may be presented at the TV set 3 as visual information, either in a separate free TV channel or overlaid any other TV channel.

All of the above described possibilities are possible to achieve by configuring the NT 5 in a proper way. It is thus convenient if the NT 5 is equipped with a WWW server, making it possible to manage the NT 5 configuration.

The above descriptions are examples of embodiments of the present invention. Someone skilled in the art will easily be able to make modifications and alternatives, which also should be considered to fall within the claims of the present invention. As an example, in the description above it is stated that the data representing the voice

is compressed before it is sent over the TV distribution network 8. It is obviously also possible to exclude this step in cases where the transmission capability is enough for sending non-compressed calls. Similarly, the protocol stacks presented are only examples of possible solutions and do not belong to the scope of the invention.

Different variations are possible, depending on the particular transmission medium used, e.g. analogue vs. digital TV distribution networks. It is also possible to use different shared media, i.e. the above described TV distribution network. In the above description a DECT solution is used. In this case a DVB is used as TV distribution network. Since the data communication channels are independent of the broadcasting channels, the DECT solution may also be used in connection with analogue TV networks.

According to the specification "Draft specification of DVB Interaction Channel based on DECT", DVB-RC-165 rev 7, vers. 4.0, march 27, 1997 it can be applied to various TV broadcasting systems, such as satellite, cable, SMATV (Satellite Master Antenna Television) terrestrial, DVB-MC (Microwave as cable), DVB-MS (Microwave as Satellite) or any future DVB broadcasting system.

DVB is also developing for including MPEG (Motion Picture Expert Group) coded video. This implies that the downstream information streams becomes bursty, why space for multiplexing other types of streams becomes available. In such systems, the interactive downstream channels are provided by the broadcasting protocols, while DECT is used only for the upstream channels.

The DECT scheme for interaction channels is one possible example. Other solutions are also available in the state of the art. The IEEE 802.14 standard discloses a standard for the physical layer and a MAC protocol for CATV networks.

The NT 5 has above been described without stating anything about the physical realisation. It is obvious for anyone skilled in the art that the NT 5 may be integrated into one single unit as well as be separated into two or more units.

5 In the description above, only the case, where one router 24 and telephony server 15, respectively are connected to one single IP access server 12, is discussed. It is of course possible for the telephony server 15 and router 24 to be a part of any kind of network system, including several IP access servers 12 or not, eventually leading to a service provider network 14, 16. Above it has not been described anything
10 about the physical realisation of these units. It is obvious for anyone skilled in the art that the IP access server 12, the telephony server 15 and the router 24 may be integrated into one single unit, forming a network node, as well as be separated into two or more units.

15 The interfaces of the NT 5 may also be assigned to other applications than PC:s 2 or telephones 1, parallel to what was discussed in the references [1] and [2]. Such other interface possibilities are e.g. interfaces for DECT systems, LAN's, digital telephones, or phones connected through LAN's. It is thus obvious that also such applications have the same type of communication possibilities, both internal and
20 external as described above.

References:

[1] Our co-pending Swedish patent application 9602212-4 filed on June 4, 1996.

[2] Our co-pending Swedish patent application 9604409-4 filed on November 29,

25 1996.

CLAIMS

1. A method to provide access to services of a multitude of different communication service networks (14, 16) over a TV distribution network (8)

5 **characterized by** using the IP protocols (40) as an internal multiplexing and transport mechanism.

2. A method in accordance with claim 1, **characterized in that** said multitude of communication service networks comprises at least one telephony
10 service network (16).

3. A method in accordance with claim 1 or 2, **characterized in that** said multitude of communication service networks comprises at least one IP based
15 network (14).

4. A method in accordance with any of the preceding claims,
characterized by provision of IP protocol handling in a network terminal
(5) connected to a user end of said TV distribution network (8).

20 5. A method in accordance with claim 4, **characterized by** carrying out said access to said telephony service network (16) via a telephony server (15) connected to an IP access server (12), which in turn is connected to a TV transmitter end (9) of said TV distribution network (8), which is common for a suitable set of users.

25 6. A method in accordance with claim 4 or 5, **characterized by** carrying out said access to said IP based network (14) via a router (24) connected to an IP access server (12), which in turn is connected to a TV transmitter end (9) of said TV distribution network (8), which is common for a suitable set of users.

7. A method in accordance with claim 5 or 6, **characterized by** association, in said telephony server (15) and/or said router (24), of an external address with an IP address in the TV distribution network.

5 8. A method in accordance with any of the claims 4 to 7, **characterized by** allowing simultaneous telephony and data communication sessions on the same network terminal (5).

9. A method in accordance with any of the claims 4 to 8,
10 **characterized by** providing said access simultaneously for more than one telephony session on the same network terminal (5).

10. A method in accordance with claim 9, **characterized in that**
15 said simultaneous telephony sessions on the same network terminal (5) are using different telephony service networks (16a-d).

11. A method in accordance with any of the claims 4 to 10,
characterized by providing said access simultaneously for more than one datacom session on the same network terminal (5).

20 12. A method in accordance with claim 11, **characterized in that** said simultaneous datacom sessions on the same network terminal (5) are given access to different IP based networks (14a-d).

25 13. A method in accordance with any of the claims 4 to 12, **characterized in that** at least one addressable unit related to one network terminal (5) is associated with more than one external address.

14. A method in accordance with any of the claims 4 to 13,
30 **characterized in that** at least one external address is associated with more than one addressable unit related to the same network terminal (5).

NT15. A method in accordance with any of the claims 4 to 14,
characterized by supporting internal telephone calls between different
telephony devices (1a, 1b) connected to the same network terminal (5).

5

16. A method in accordance with any of the claims 4 to 15,
characterized by supporting internal datacom sessions between different
computer devices (2) connected to the same network terminal (5).

10

17. A method in accordance with any of the preceding claims,
characterized by providing users of the same network terminal (5) with
access to several different telephony service networks (16a-d).

15

18. A method in accordance with claim 17, **characterized by** select-
ing required telephony service network (16a-d) on a per call basis.

19. A method in accordance with any of the preceding claims,
characterized by providing users of the same network terminal (5) with
access to several different IP based networks (14a-d).

20

20. A method in accordance with claim 19, **characterized by** select-
ing required IP based network (14a-d) on a per session basis.

25

21. A method in accordance with any of the preceding claims,
characterized by supporting internal telephone calls between different
telephony devices (1a, 1c) connected to the same TV distribution network (8).

30

22. A method in accordance with any of the preceding claims,
characterized by supporting internal datacom sessions between different
computer devices (2) connected to the same TV distribution network (8).

23. A network terminal (5) for providing access to services of a multitude of different communication service networks (14, 16) over a TV distribution network (8), **characterized in that** said network terminal (5) is located at the user end of said TV distribution network (8) and comprises means using the IP protocols (40) as an internal multiplexing and transport mechanism.

24. A network terminal (5) in accordance with claim 23, **characterized in that** said multitude of communication service networks comprises at least one telephony service network (16).

25. A network terminal (5) in accordance with claim 23 or 24, **characterized in that** said multitude of communication service networks comprises at least one IP based network (14).

26. A network terminal (5) in accordance with claim 25, **characterized in that** said network terminal (5) comprises at least one interface (6, 7) to a terminal unit (1, 2).

27. A network terminal (5) in accordance with claim 26, **characterized in that** said network terminal (5) comprises at least one telephony interface (6), supporting communication for access to said telephony network (16).

28. A network terminal (5) in accordance with claim 26 or 27, **characterized in that** said network terminal (5) comprises at least one PC/LAN interface (7), supporting communication for access to said IP based network (14).

29. A network terminal (5) in accordance with any of the claim 25 to 28, **characterized in that** said network terminal (5) comprises applications (33) for telephony, IP traffic and management of the network terminal (5) configuration.

30. A network terminal (5) in accordance with any of the claim 25 to 29,
characterized in that said network terminal (5) comprises means for
communication with said management application of said network terminal (5), for
5 enabling modification of the configuration of said network terminal (5).

31. A telephony server (15) for providing access to services of at least one te-
lephony network (16) over a TV distribution network (8), **characterized in**
that said telephony server (15) is connected to an IP access server (12), which in
10 turn is connected to the TV transmitter end (9) of said TV distribution network (8),
and said telephony server (15) comprises means using the IP protocols (40) as an
internal multiplexing and transport mechanism.

32. A telephony server (15) in accordance with claim 31, **characterized**
15 **in that** said telephony server (15) has access to more than one telephony net-
work (16a-d).

33. A telephony server (15) in accordance with claim 31 or 32,
characterized in that said telephony server (15) comprises a telephony
20 application (50a).

34. A telephony server (15) in accordance with claim 31, 32 or 33,
characterized by means for associating an external telephony address
with an internal IP address.

25 35. A telephony server (15) in accordance with any of the claim 31 to 34,
characterized in that said telephony server (15) comprises an applica-
tion for management of the telephony server (15) and means for communication with
said management application, for enabling modification of the configuration of te-
30 lephony server (15).

36. A router (24) for providing access to services of at least one IP based network (14) over a TV distribution network (8), **characterized in that** said router (24) is connected to an IP access server (12), which in turn is connected to the TV transmitter end (9) of said TV distribution network (8), and said router (24) comprises means using the IP protocols (40) as an internal multiplexing and transport mechanism.

37. A router (24) in accordance with claim 36, **characterized in that** said router (24) has access to more than IP based network (14a-d).

38. A router (24) in accordance with claim 37, **characterized in that** said router (24) has an IP application (60a) which communicates with said IP based networks (14).

39. A router (24) in accordance with any of the claims 36 to 38, **characterized by** means for associating an external IP address with an internal IP address.

40. A router (24) in accordance with any of the claims 36 to 39, **characterized in that** said router (24) comprises an application for management of the router (24) and means for communication with said management application, for enabling modification of the configuration of router (24).

41. A network node providing access to services of at least one IP based network (14, 14a-d) as well as the services of at least one telephony service network (16, 16a-d) **characterized by** an IP access server (12), a router (24) connected to the IP access server (12) and with IP interfaces for connection to a respective one of said IP based networks (14, 14a-d), a telephony server (15) connected to the IP access server (12) and with a number of telephony interfaces for connection to a respective one of said telephony service networks (16, 16a-d).

42. An arrangement for providing access to services of an IP based network over a TV distribution network (8), **characterized by** a network terminal (5) located at the user end of said TV distribution network (8), a telephony server (15) connected to an IP access server (12), which in turn is connected to the TV transmitter end (9) of said TV distribution network (8), and a router (24) connected to said IP access server (12), using the IP protocols (24) as an internal multiplexing and transport mechanism.

43. An access network comprising a network terminal (5) and a network node, the network node having a telephony network interface **characterized by** said network node comprising:

an IP access server (12),

a router (24) connected to the IP access server (12) and having an IP network interface,

a telephony server (15) connected to the IP access server (12) and to said telephony network interface,

said number of network terminals (5) being connected to said IP access server (12) at TV distribution network (8) interfaces provided in the IP access server (12).

44. An access network in accordance with claim 43, wherein there are several IP based networks (14a-d) **characterized by** said router (24) having several IP network interfaces, each one of which is connected to a respective one of said several IP networks (14a-d).

45. An access network in accordance with claim 43, wherein there are several telephony service networks (16a-d) **characterized by** said telephony server (15) having several telephony network interfaces, each one of which is connected to a respective one of said telephony service networks (16a-d).

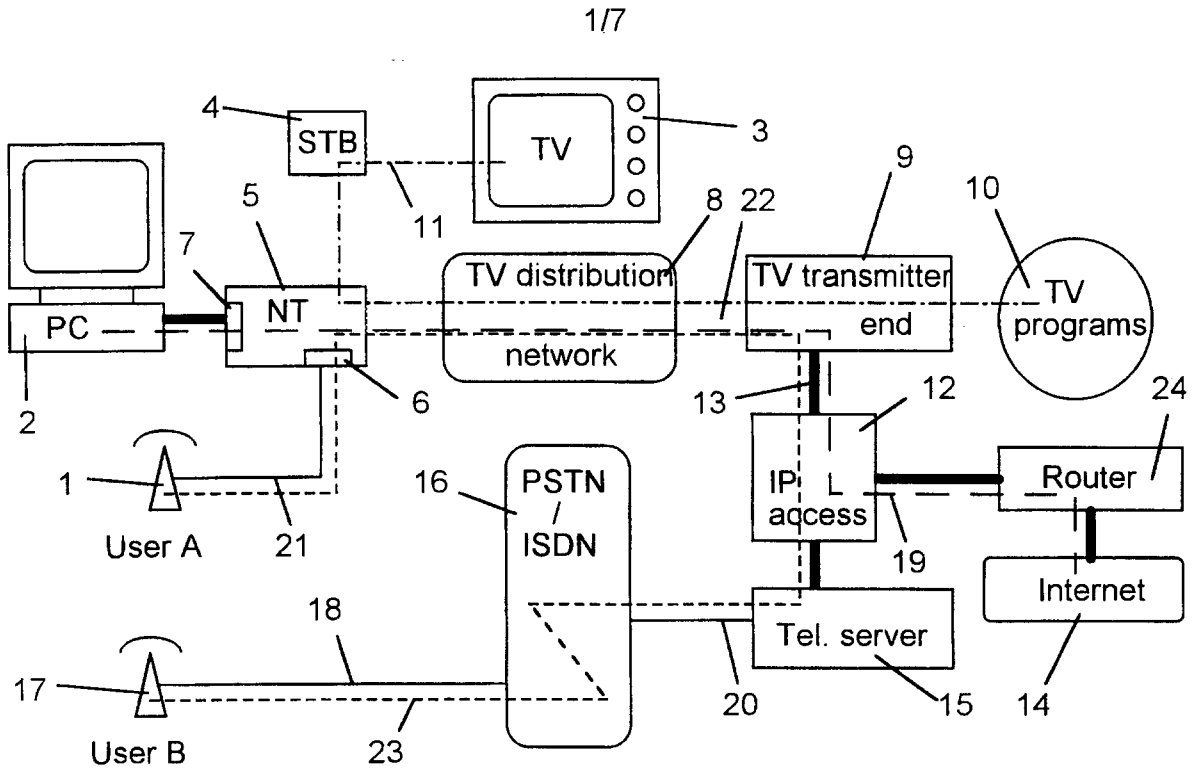

Fig. 1

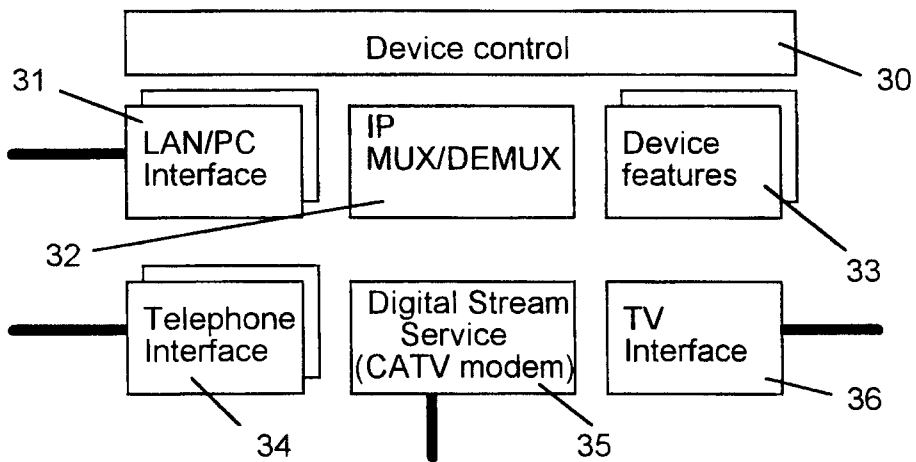

Fig. 2

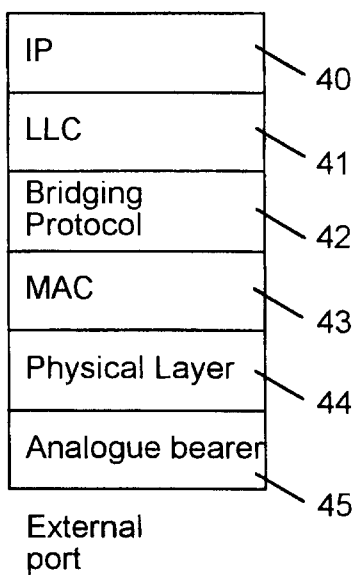

Fig. 3a

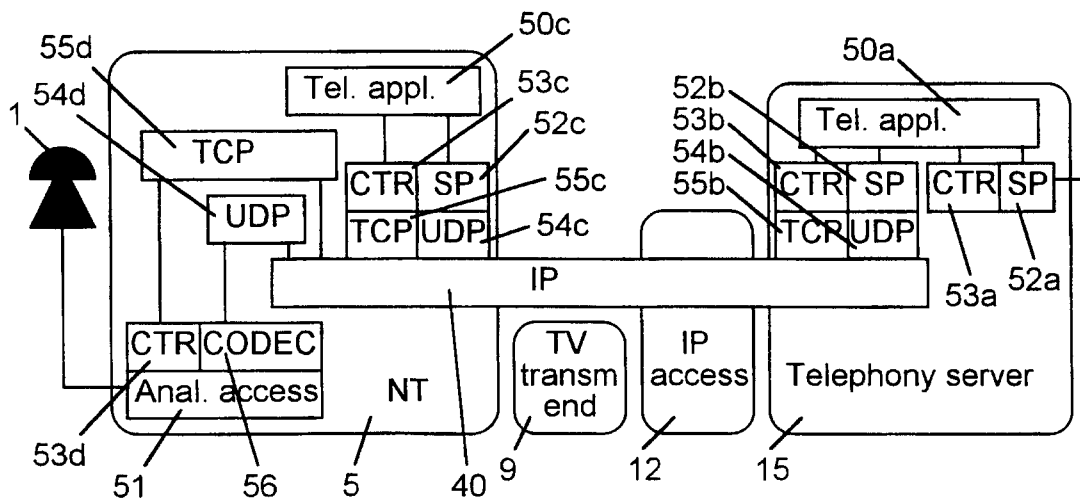

Fig. 3b

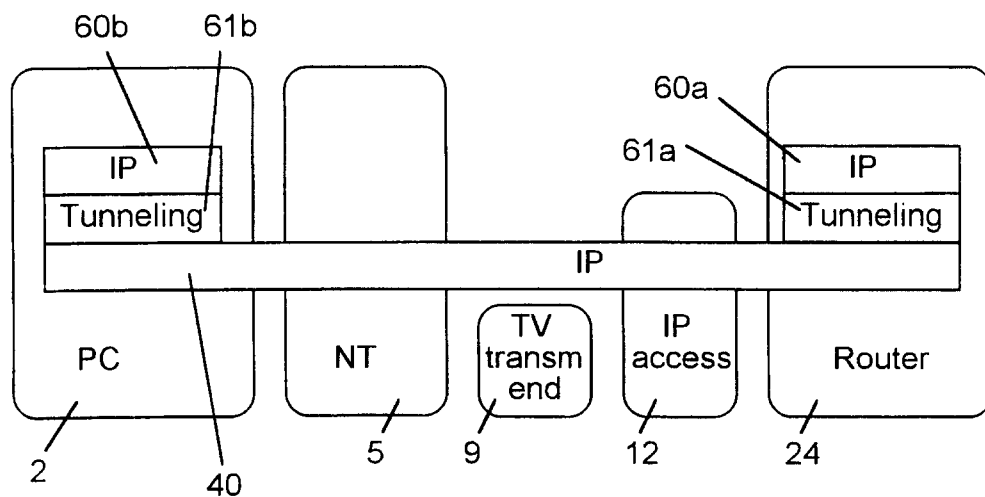

Fig. 3c

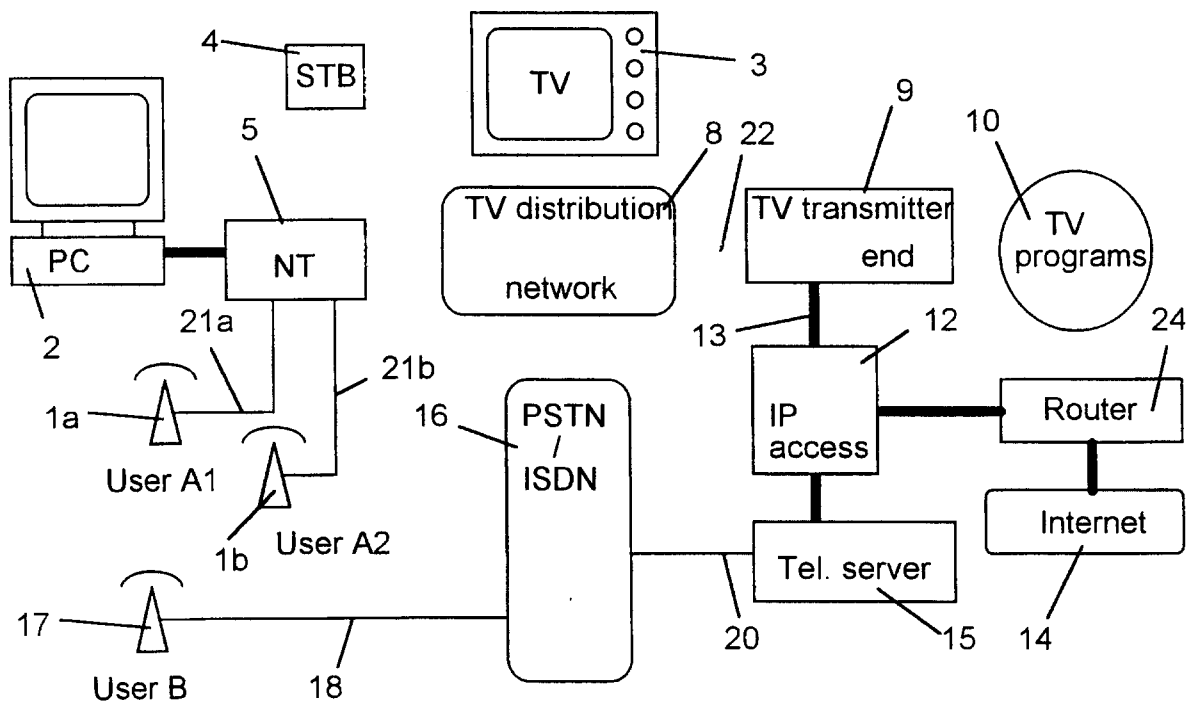

Fig. 4

4/7

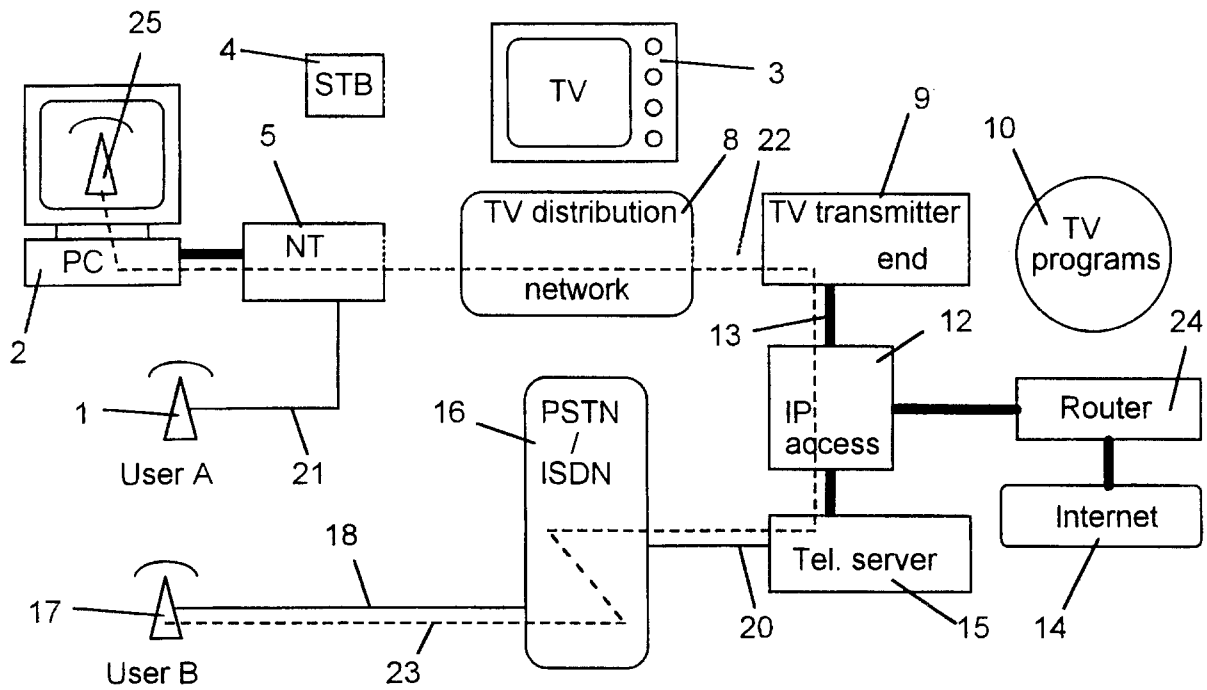

Fig. 5

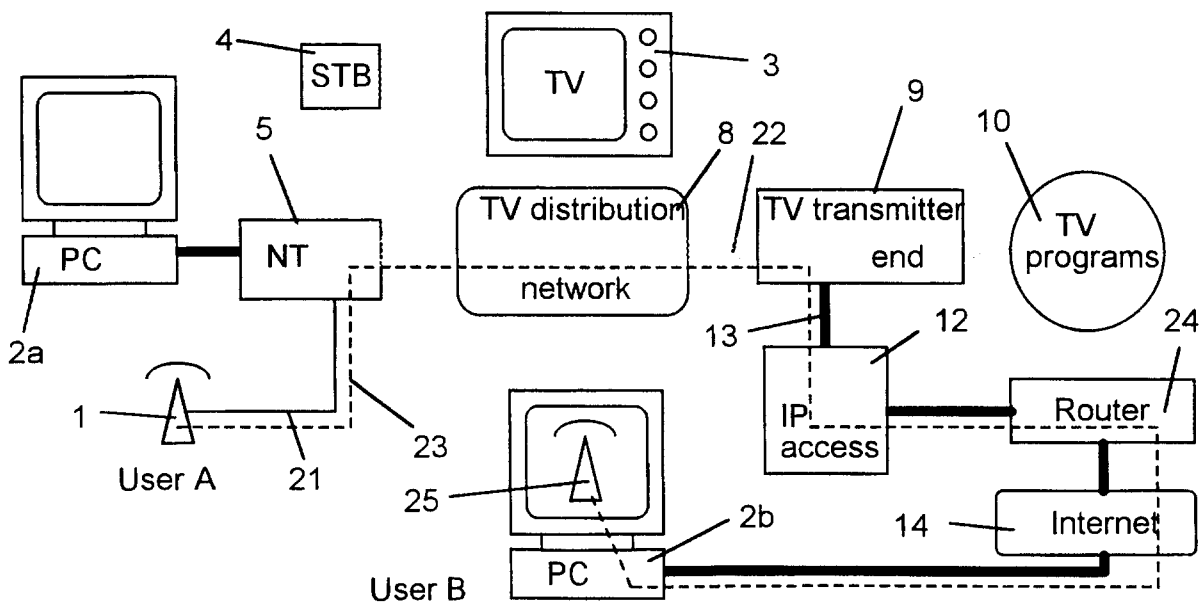

Fig. 6

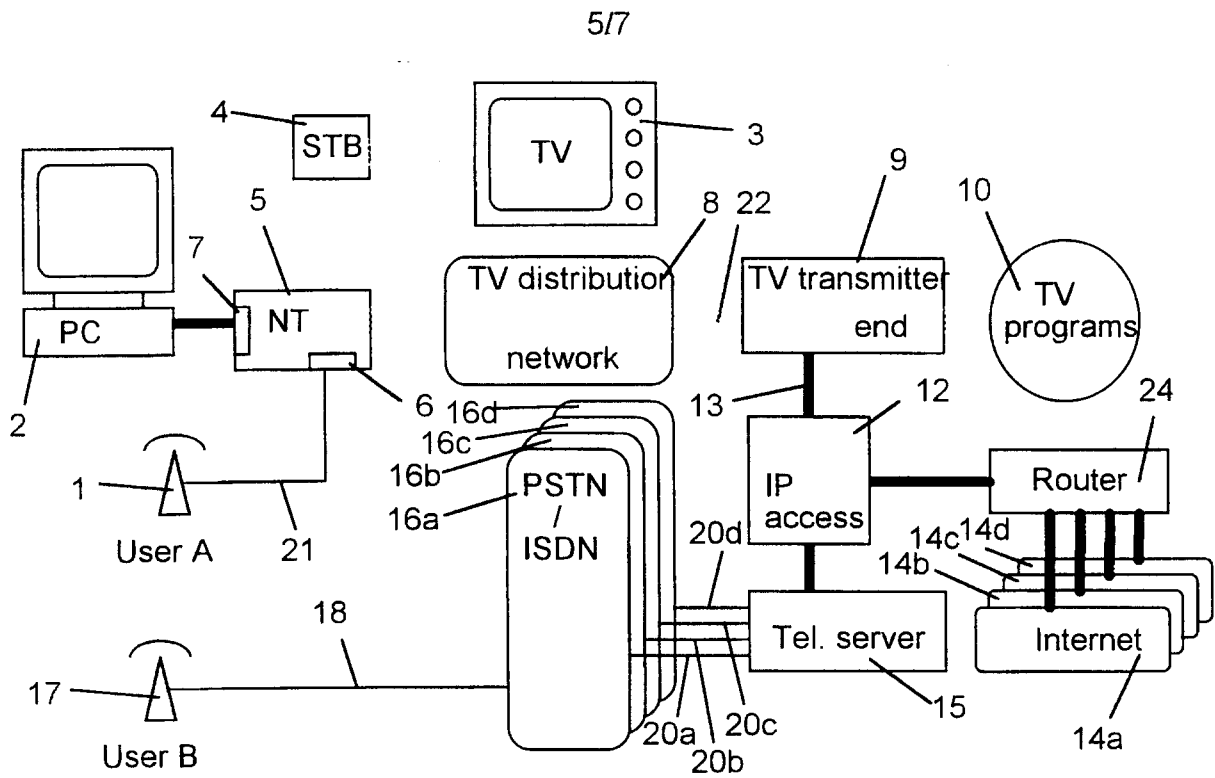

Fig. 7

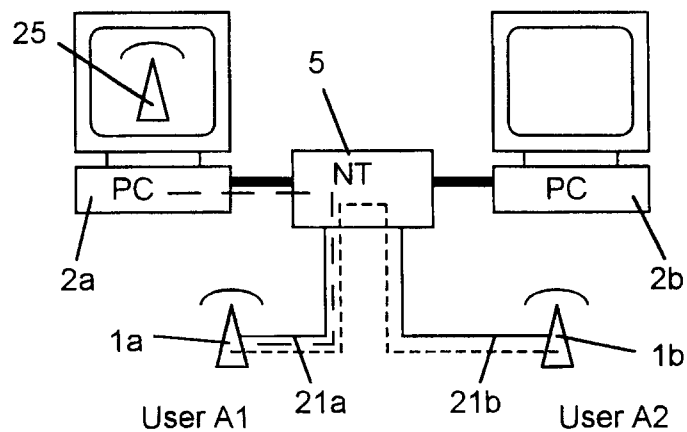

Fig. 8

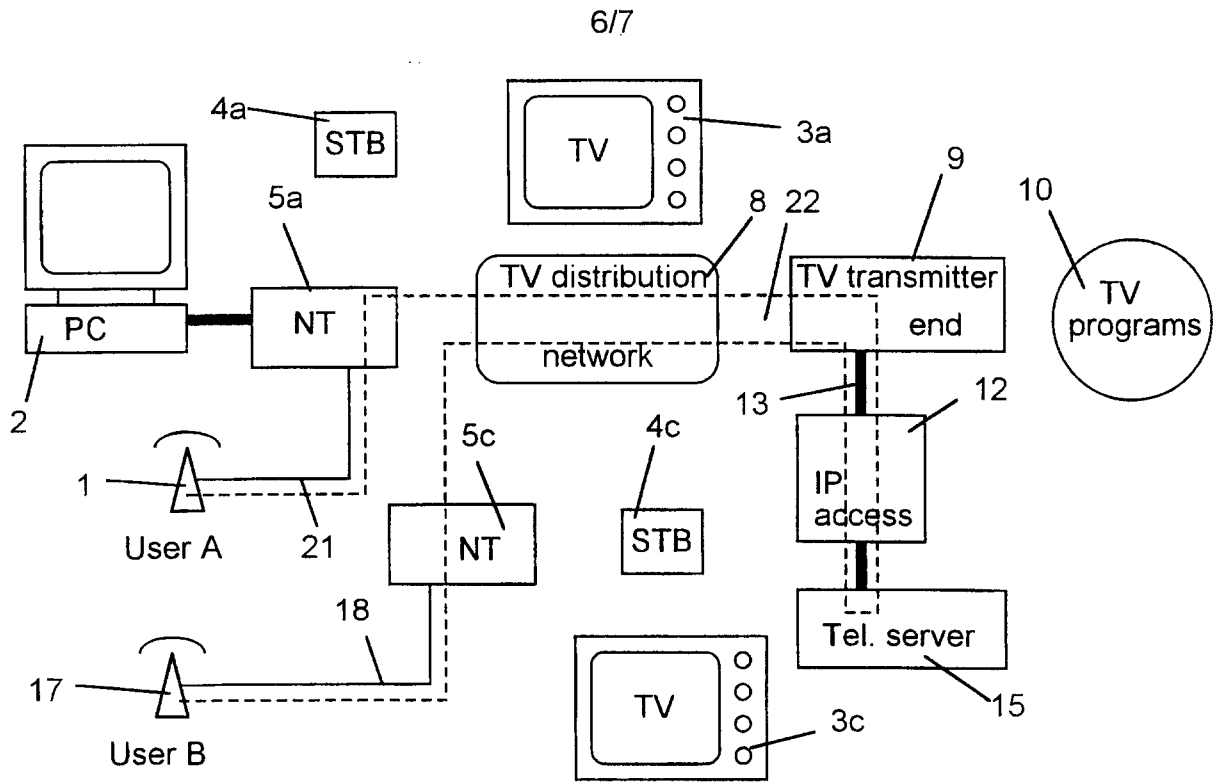

Fig. 9

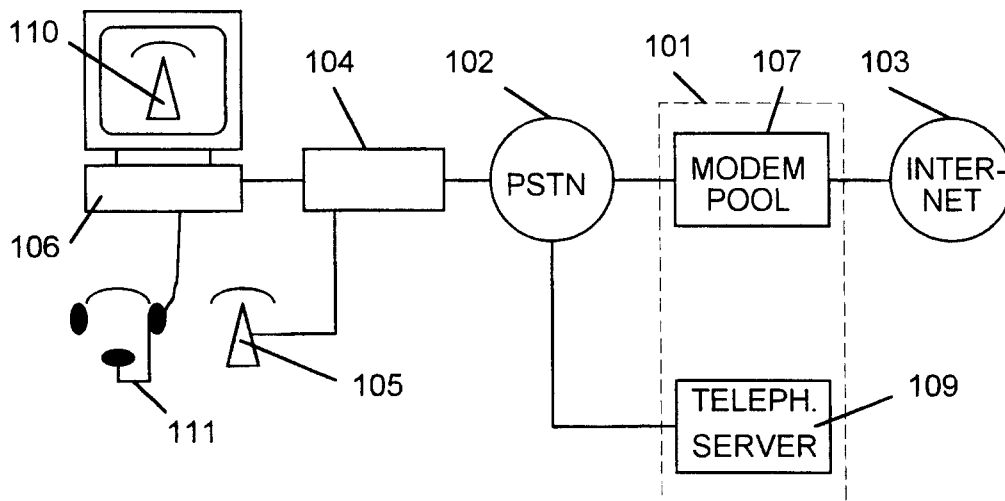

Fig. 10

7/7

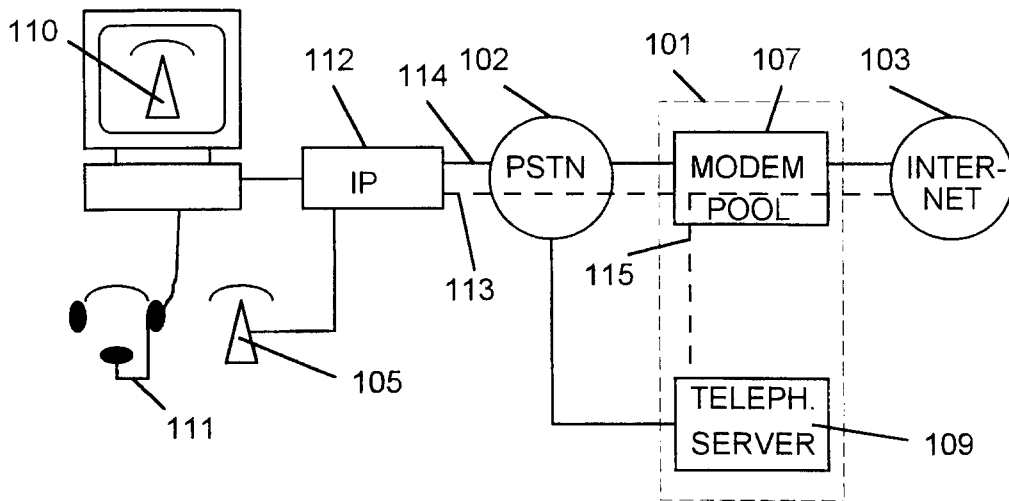

Fig. 11

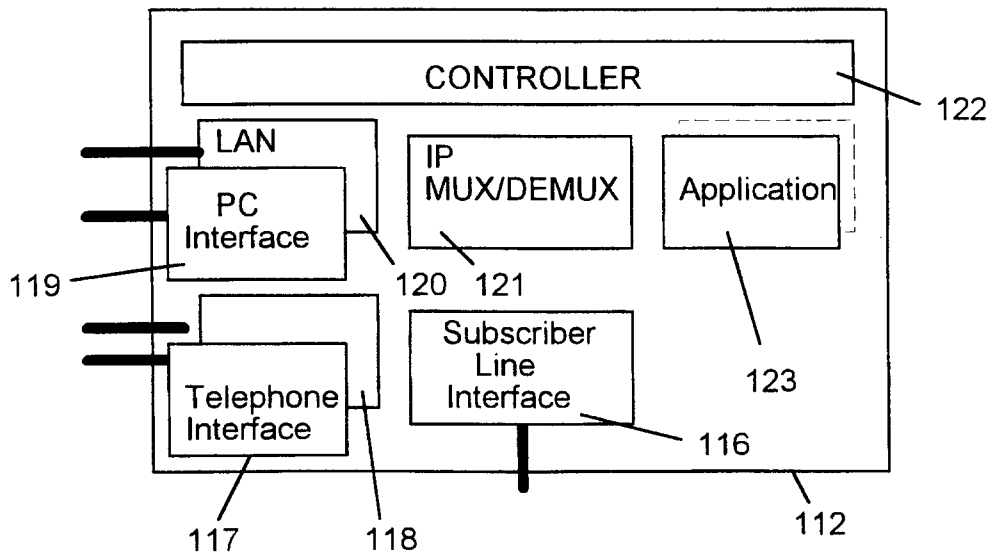

Fig. 12

