



- (51) **International Patent Classification:**
A61B 8/00 (2006.01) *G06T 7/20* (2006.01)
G01N 29/24 (2006.01)
- (21) **International Application Number:** PCT/US20 12/07 1923
- (22) **International Filing Date:** 28 December 2012 (28.12.2012)
- (25) **Filing Language:** English
- (26) **Publication Language:** English
- (30) **Priority Data:**
61/581,583 29 December 2011 (29.12.2011) US
61/691,717 21 August 2012 (21.08.2012) US
- (71) **Applicant:** MAUI IMAGING, INC. [US/US]; 256 Gibraltar Drive, Suite 107, Sunnyvale, CA 94089 (US).
- (72) **Inventors:** BREWER, Kenneth, D.; 256 Gibraltar Drive, Suite 107, Sunnyvale, CA 94089 (US). SMITH, David, M.; 256 Gibraltar Drive, Suite 107, Sunnyvale, CA 94089 (US). LORENZATO, Rozalin, M.; 256 Gibraltar Drive, Suite 107, Sunnyvale, CA 94089 (US). RITZI, Bruce, R.; 256 Gibraltar Drive, Suite 107, Sunnyvale, CA 94089 (US).
- (74) **Agents:** THOMAS, Justin et al; SHAY GLENN LLP, 2755 Campus Drive, Suite 210, San Mateo, CA 94403 (US).
- (81) **Designated States (unless otherwise indicated, for every kind of national protection available):** AE, AG, AL, AM, AO, AT, AU, AZ, BA, BB, BG, BH, BN, BR, BW, BY, BZ, CA, CH, CL, CN, CO, CR, CU, CZ, DE, DK, DM, DO, DZ, EC, EE, EG, ES, FI, GB, GD, GE, GH, GM, GT, HN, HR, HU, ID, IL, IN, IS, JP, KE, KG, KM, KN, KP, KR, KZ, LA, LC, LK, LR, LS, LT, LU, LY, MA, MD, ME, MG, MK, MN, MW, MX, MY, MZ, NA, NG, NI, NO, NZ, OM, PA, PE, PG, PH, PL, PT, QA, RO, RS, RU, RW, SC, SD, SE, SG, SK, SL, SM, ST, SV, SY, TH, TJ, TM, TN, TR, TT, TZ, UA, UG, US, UZ, VC, VN, ZA, ZM, ZW.
- (84) **Designated States (unless otherwise indicated, for every kind of regional protection available):** ARIPO (BW, GH, GM, KE, LR, LS, MW, MZ, NA, RW, SD, SL, SZ, TZ, UG, ZM, ZW), Eurasian (AM, AZ, BY, KG, KZ, RU, TJ, TM), European (AL, AT, BE, BG, CH, CY, CZ, DE, DK, EE, ES, FI, FR, GB, GR, HR, HU, IE, IS, IT, LT, LU, LV, MC, MK, MT, NL, NO, PL, PT, RO, RS, SE, SI, SK, SM, TR), OAPI (BF, BJ, CF, CG, CI, CM, GA, GN, GQ, GW, ML, MR, NE, SN, TD, TG).

[Continued on nextpage]

(54) **Title:** M-MODE ULTRASOUND IMAGING OF ARBITRARY PATHS

Fig. 4A

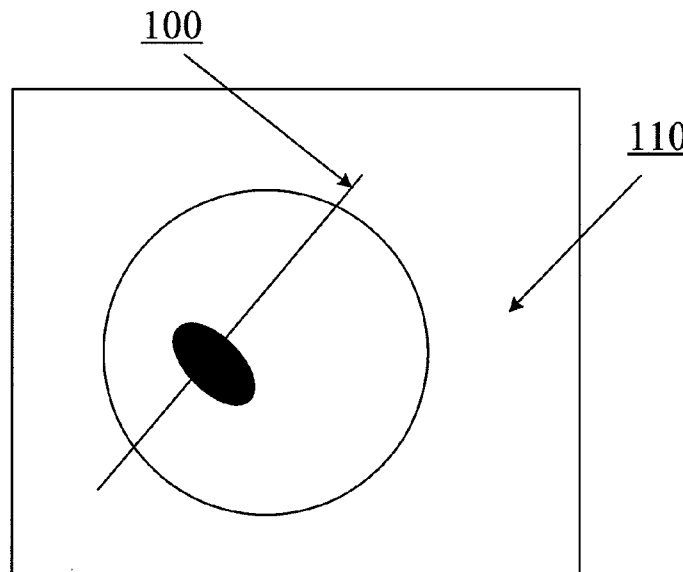

(57) **Abstract:** Systems and methods of M-mode ultrasound imaging allows for M-mode imaging along user-defined paths. In various embodiments, the user-defined path can be a non-linear path or a curved path. In some embodiments, a system for M-mode ultrasound imaging can comprise a multi-aperture probe with at least a first transmitting aperture and a second receiving aperture. The receiving aperture can be separate from the transmitting aperture. In some embodiments, the transmitting aperture can be configured to transmit an unfocused, spherical, ultrasound ping signal into a region of interest. The user-defined path can define a structure of interest within the region of interest.

WO 2013/101988 A1

Published:

— with international search report (Art. 21(3))

— before the expiration of the time limit for amending the claims and to be republished in the event of receipt of amendments (Rule 48.2(h))

M-MODE ULTRASOUND IMAGING OF ARBITRARY PATHS**CROSS REFERENCE TO RELATED APPLICATIONS**

[0001] This application claims the benefit of US Provisional Patent Application 61/581,583, titled "M-Mode Ultrasound Imaging Of Arbitrary Paths", filed on December 29, 2011, and US
5 Provisional Patent Application 61/691,717, titled "Raw Data Memory Architecture", filed on August 21, 2012, both of which are incorporated herein by reference.

INCORPORATION BY REFERENCE

[0002] All publications and patent applications mentioned in this specification are herein incorporated by reference to the same extent as if each individual publication or patent
10 application was specifically and individually indicated to be incorporated by reference.

FIELD

[0003] This invention generally relates to ultrasound imaging, and more particularly to M-mode imaging of arbitrary paths.

BACKGROUND

15 [0004] Conventional ultrasound (or "scanline based" ultrasound as used herein) utilizes a phased array controller to produce and steer a substantially linear transmit waveform. In order to produce a B-mode image, a sequence of such linear waveforms (or "scanlines") may be produced and steered so as to scan across a region of interest. Echoes are received along each respective scanline. The individual scanlines from a complete scan may then be combined to
20 form a complete image (sometimes referred to as a "sector scan" image).

[0005] A display method known as M-mode (or motion mode) imaging is commonly used in cardiology and other fields where it is desirable to view the motion of imaged objects. In some forms of M-mode imaging, echoes from a one-dimensional line are displayed over time relative to a static reference point in order to allow a clinician to evaluate movement of a particular
25 structure (such as a cardiac wall or valve) over time. Because a traditional scanline-based ultrasound path is directional (along the scanline axis), available M-mode lines tend to be limited to paths along a scanline.

[0006] Generally, M-mode imaging provides a graphic indication of positions and movements of structures within a body over time. In some cases, a single stationary focused
30 acoustic beam is fired at a high frame rate and the resulting M-mode images or lines are displayed side-by-side, providing an indication of the function of a heart over multiple heart cycles.

SUMMARY OF THE DISCLOSURE

[0007] A method of defining and displaying an m-mode path for display in an ultrasound imaging system, the method comprising transmitting an ultrasound signal from a transmitting transducer element into a region of interest including a structure of interest, receiving echoes
5 with at least one receiving transducer element, producing an image of the region of interest from the received echoes, displaying the image of the region of interest including the structure of interest to a user, defining a one-pixel-wide path through the structure of interest, where the path does not lie along a line that intersects the transmitting transducer element or the receiving transducer element, and displaying a graph of a magnitude of pixels along the path over time.

10 [0008] In some embodiments, the path is non-linear. In other embodiments, the path has at least one curved segment. In one embodiment, the path has at least one linear segment and at least one curved segment. In another embodiment, the path has at least two linear segments that intersect at an angle other than 180 degrees. In some embodiments, the path has at least two discontinuous segments.

15 [0009] In one embodiment, the transmitting transducer element lies on a separate physical transducer array from an array containing the at least one receiving transducer element.

[0010] In another embodiment, the transmitting transducer is configured to transmit an unfocused ping ultrasound signal into the region of interest.

[0011] In some embodiments, the method further comprises receiving echoes from the
20 entire region of interest with the at least one receiving transducer element, receiving echoes from the entire region of interest with a second receiving transducer element, and producing an image of the region of interest by combining echoes received at the first and second transducer elements.

[0012] In some embodiments, defining a path through the structure of interest is performed
25 substantially concurrently with said transmitting and receiving.

[0013] In another embodiment, the transmitting transducer is configured to insonify a phased array scan line.

[0014] A method of ultrasound imaging is also provided, comprising transmitting
30 ultrasound signals into a region of interest and receiving echoes of the transmitted ultrasound signals with an ultrasound probe, defining a first image window as a portion of the region of interest, identifying an M-mode path intersecting a feature visible in the first image window, displaying data representing the M-mode path on a common display with a B-mode image of the first image window, defining a second image window as a portion of the region of interest that is different than the first image window, and displaying the data representing the M-mode path on a
35 common display with a B-mode image of the second image window.

[0015] In one embodiment, all of the method steps are performed during a live real-time imaging session.

[0016] In another embodiment, the M-mode path includes at least one non-linear segment. In one embodiment, the M-mode path is not a line intersecting the probe.

5 [0017] In another embodiment, all of the method steps are performed using stored raw echo data retrieved from a raw data memory device.

[0018] In some embodiments, the first image window is smaller than and lies entirely within the second image window. In another embodiment, the second image window does not overlap the first image window.

10 [0019] In an additional embodiment, the method further comprises simultaneously displaying the data of the M-mode path on a common display with B-mode images of both the first image window and the second window.

[0020] In some embodiments, the M-mode path has at least two dis-continuous segments.

[0021] A multi-aperture M-mode ultrasound imaging system is also provided, comprising a
15 transmitting transducer element configured to transmit an ultrasound signal into a region of interest including a structure of interest, a receiving transducer element separate from the transmitting transducer element, the receiving transducer element configured to receive echoes from the ultrasound signal, a controller configured to produce an image of the region of interest from the received echoes, an input mechanism configured to receive a user input defining a one-
20 pixel-wide path through the structure of interest, where the path does not lie along a line that intersects the transmitting transducer element or the receiving transducer element, and a display configured to display the region of interest including the structure of interest, the display also configured to display a graph of a magnitude of pixels along the path over time.

[0022] In some embodiments, the transmitting transducer is configured to transmit an
25 unfocused ping ultrasound signal into the region of interest.

[0023] In another embodiment, the transmitting transducer is configured to transmit an unfocused spherical ping ultrasound signal into the region of interest. In some embodiments, the transmitting transducer is configured insonify a phased array scan line.

30 **BRIEF DESCRIPTION OF THE DRAWINGS**

[0024] The novel features of the invention are set forth with particularity in the claims that follow. A better understanding of the features and advantages of the present invention will be obtained by reference to the following detailed description that sets forth illustrative

embodiments, in which the principles of the invention are utilized, and the accompanying drawings of which:

[0025] Having thus summarized the general nature of the invention, embodiments and modifications thereof will become apparent to those skilled in the art from the detailed description below with reference to the attached figures.

[0026] FIG. 1A is a block diagram illustrating components of an ultrasound imaging system.

[0027] FIG. 1B is a block diagram illustrating another embodiment of an ultrasound imaging system.

[0028] FIG. 2 is a section view of a multiple aperture ultrasound imaging probe.

10 [0029] FIG. 3 is a schematic illustration of a multiple aperture ultrasound imaging process using a point-source transmit signal.

[0030] FIG. 4A is an illustration of a B-mode ultrasound image with an M-mode path defined through a portion of an imaged object.

15 [0031] FIG. 4B is an illustration of an M-mode graph of the data along the M-mode path of FIG. 4A.

[0032] FIG. 5A is an illustration of a B-mode ultrasound image with multiple M-mode paths defined through a portion of an imaged object.

[0033] FIG. 5B is an illustration of an M-mode graph of the data along the multiple m-mode paths of FIG. 5A.

20

DETAILED DESCRIPTION

[0034] In traditional ultrasound systems, images are generated by combining echoes from a series of pulses transmitted as phased array scan lines. In such scanline-based ultrasound imaging systems, the coordinate system used by the user interface usually lies along the scan lines. As a result, in such systems, a user interface for selecting an M-mode line typically involves selecting a desired segment of one of the scan lines. However, requiring the use of scan lines as M-mode lines means that the sonographer must position and hold the probe such that at least one of the scanlines intersects an anatomical feature through which an M-mode line is desired. In practice, this may be difficult and/or time consuming, and may limit the field of view.

25 [0035] Embodiments below provide systems and methods for obtaining M-mode data substantially in real-time along an arbitrary and/or user-defined path that does not necessarily lie along an ultrasound scan line. In some embodiments, the path may be a one-dimensional straight line. In other embodiments, the path may comprise a zig-zag pattern, a curved path, or any other non-linear path. As used herein the term "one-dimensional" may refer to a narrow path, whether linear, curved, or otherwise shaped. In some embodiments, a one-dimensional path may have a

30

width of a single display pixel. In other embodiments, a one-dimensional path may have a width greater than one display pixel (e.g., 2 or 3 pixels), but may still have a length that is substantially greater than its width. As will be clear to the skilled artisan, the relationship between actual dimensions of represented objects and image pixels may be any value defined by the imaging system. In some embodiments, the M-mode path is not necessarily a straight line, and may include components at any orientation within the scan plane.

[0036] In some embodiments, an ultrasound imaging system may be configured to obtain three-dimensional (3D) image data, in which case an M-mode path may be selected from a displayed 3D volume. For example, an M-mode path may be defined in a 3D volume by selecting a desired plane through the 3D volume, and then defining an M-mode path within the selected 2D plane using any of the systems and methods described herein.

[0037] Some embodiments of systems and methods for specifying and displaying arbitrary M-mode lines may be used in conjunction with ping-based and/or multiple aperture ultrasound imaging systems. In other embodiments, systems and methods for specifying and displaying arbitrary M-mode lines as shown and described herein may also be used in conjunction with scanline-based imaging systems.

Ultrasound Imaging System Components

[0038] FIG. 1A is a block diagram illustrating components of an ultrasound imaging system that may be used with some embodiments of M-mode imaging systems and methods. The ultrasound system 10 of FIG. 1A may be particularly suited for scanline-based imaging and may be configured for acquiring real-time cardiac images either as 2D tomographic slices or as volumetric image data. The system may include a central controller/processor configured to control the other system components, including the probe 12 which includes one or more transducer arrays, elements of which may transmit and/or receive ultrasound signals. In some embodiments, the transducer array(s) may include a 1D, 2D or other dimensional arrays formed from any suitable transducer material. The probe may generally be configured to transmit ultrasonic waves and to receive ultrasonic echo signals. In some embodiments, such transmission and reception may be controlled by a controller which may include a beamformer 14. The echo information from the beamformer 14 may then be processed by a B-mode processor 20 and/or other application-specific processors as needed (e.g., Doppler processors, contrast signal processors, elastography processors, etc).

[0039] The B-Mode processor 20 may be configured to perform functions that include but are not limited to filtering, frequency and spatial compounding, harmonic data processing and other B-Mode functions. In some embodiments, the processed data may then be passed through a

scan converter 24 configured to geometrically correct the data from a linear or polar geometry used by a phased-array scanning probe into a Cartesian format (x,y or x,y,z) with appropriate scaling in each dimension. In some embodiments, such as the embodiment described below with reference to FIGs. 2 & 3, a scan converter 24 may be omitted from the system.

5 [0040] Data for each 2D image or 3D volume may then be stored in a memory 28. The memory 28 may be volatile and/or non-volatile memory configured to store a few seconds up to several minutes or more of 2D or 3D echo image data. The video processor 26 may be configured to take the echo data stored in memory 28 and instructions from the central controller 16 to form video images, including any added graphic overlays and/or text annotation (e.g.
10 patient information). Processed video data may then be passed on to the display 30 for presentation to the operator. The central controller 16 can direct the video processor 26 to display the most recently acquired data in memory as a real-time display, or it can replay sequences of older stored 2D slice or 3D volume data.

[0041] An M-mode processor 235 may also be provided to receive a definition of an M-
15 mode path from a user interface and to form the images displaying the selected M-mode data in a desired output format. In some embodiments, an M-mode processor 235 may also include a (volatile or non-volatile) memory device for storing the defined M-mode path. In some embodiments, an M-mode processor 235 may be logically positioned between the video
processor 26 and the display 30 in the diagram of FIG. 1A. In other embodiments, an M-mode
20 processor 235 may be a set of functions built into the video processor 26 or another component of the system.

[0042] FIG. 1B illustrates another embodiment of an ultrasound imaging system 200 comprising an ultrasound probe 202 which may include a plurality of individual ultrasound transducer elements, some of which may be designated as transmit elements, and others of which
25 may be designated as receive elements. In some embodiments, each probe transducer element may convert ultrasound vibrations into time-varying electrical signals and vice versa. In some embodiments, the probe 202 may include any number of ultrasound transducer arrays in any desired configuration. A probe 202 used in connection with the systems and methods described herein may be of any configuration as desired, including single aperture and multiple aperture
30 probes.

[0043] The transmission of ultrasound signals from elements of the probe 202 may be controlled by a transmit controller 204. Upon receiving echoes of transmit signals, the probe elements may generate time-varying electric signals corresponding to the received ultrasound vibrations. Signals representing the received echoes may be output from the probe 202 and sent
35 to a receive subsystem 210. In some embodiments, the receive subsystem may include multiple

channels, each of which may include an analog front-end device ("AFE") 212 and an analog-to-digital conversion device (ADC) 214. In some embodiments, each channel of the receive subsystem 210 may also include digital filters and data conditioners (not shown) after the ADC 214. In some embodiments, analog filters prior to the ADC 214 may also be provided. The

5 output of each ADC 214 may be directed into a raw data memory device 220. In some embodiments, an independent channel of the receive subsystem 210 may be provided for each receive transducer element of the probe 202. In other embodiments, two or more transducer elements may share a common receive channel.

[0044] In some embodiments, an analog front-end device 212 (AFE) may perform certain

10 filtering processes before passing the signal to an analog-to-digital conversion device 214 (ADC). The ADC 214 may be configured to convert received analog signals into a series of digital data points at some pre-determined sampling rate. Unlike most ultrasound systems, some embodiments of the ultrasound imaging system of FIG. 1B may then store digital data representing the timing, phase, magnitude and/or the frequency of ultrasound echo signals

15 received by each individual receive element in a raw data memory device 220 before performing any further beamforming, filtering, image layer combining or other image processing.

[0045] In order to convert the captured digital samples into an image, the data into an image, the data may be retrieved from the raw data memory 220 by an image generation subsystem 230. As shown, the image generation subsystem 230 may include a beamforming block 232 and an

20 image layer combining ("ILC") block 234. In some embodiments, a beamformer 232 may be in communication with a calibration memory 238 that contains probe calibration data. Probe calibration data may include information about the precise acoustic position, operational quality, and/or other information about individual probe transducer elements. The calibration memory 238 may be physically located within the probe, within the imaging system, or in location

25 external to both the probe and the imaging system.

[0046] In some embodiments, after passing through the image generation block 230, image data may then be stored in an image buffer memory 236 which may store beamformed and (in some embodiments) layer-combined image frames. A video processor 242 within a video subsystem 240 may then retrieve image frames from the image buffer, and may process the

30 images into a video stream that may be displayed on a video display 244 and/or stored in a video memory 246 as a digital video clip, e.g. as referred to in the art as a "cine loop".

[0047] An M-mode processor 235 may also be provided to receive a definition of an M-mode path from a user interface and to form the images displaying the selected M-mode data in a desired output format. In some embodiments, an M-mode processor 235 may also include a

35 (volatile or non-volatile) memory device for storing the defined M-mode path. In some

embodiments, an M-mode processor 235 may be logically positioned between the image buffer 236 and the video processor 242 in the diagram of FIG. 1B. In other embodiments, an M-mode processor 235 may be a set of functions built into the image generation subsystem 230 or the video processor 242 or any other suitable component of the system.

5 [0048] In some embodiments, raw echo data stored in a memory device may be retrieved, beamformed, processed into images, and displayed on a display using a device other than an ultrasound imaging system. For example, such a system may omit the probe 202, the transmit controller 204 and the receive sub-system 210 of FIG. 1B, while including the remaining components. Such a system may be implemented predominantly in software running on general
10 purpose computing hardware. Such alternative processing hardware may comprise a desktop computer, a tablet computer, a laptop computer, a smartphone, a server or any other general purpose data processing hardware.

Introduction to Ping-Based Imaging

[0049] Some embodiments of ultrasound imaging systems to be used in combination with
15 the systems and methods described herein may use point source transmission of ultrasound signals during the transmit pulse. An ultrasound wavefront transmitted from a point source (also referred to herein as a "ping") illuminates the entire region of interest with each circular or spherical wavefront. Echoes from a single ping received by a single receive transducer element may be beamformed to form a complete image of the insonified region of interest. By combining
20 data and images from multiple receive transducers across a wide probe, and by combining data from multiple pings, very high resolution images may be obtained.

[0050] As used herein the terms "point source transmission" and "ping" may refer to an introduction of transmitted ultrasound energy into a medium from a single spatial location. This may be accomplished using a single ultrasound transducer element or combination of adjacent
25 transducer elements transmitting together. A single transmission from one or more element(s) may approximate a uniform spherical wave front, or in the case of imaging a 2D slice, may create a uniform circular wavefront within the 2D slice. In some cases, a single transmission of a circular or spherical wavefront from a point source transmit aperture may be referred to herein as a "ping" or a "point source pulse" or an "unfocused pulse."

30 [0051] Point source transmission differs in its spatial characteristics from a scanline-based "phased array transmission" or a "directed pulse transmission" which focuses energy in a particular direction (along a scanline) from the transducer element array. Phased array transmission manipulates the phase of a group of transducer elements in sequence so as to strengthen or steer an insonifying wave to a specific region of interest.

[0052] Images may be formed from such ultrasound pings by beamforming the echoes received by one or more receive transducer elements. In some embodiments, such receive elements may be arranged into a plurality of apertures in a process referred to as multiple aperture ultrasound imaging.

5 [0053] Beamforming is generally understood to be a process by which imaging signals received at multiple discrete receptors are combined to form a complete coherent image. The process of ping-based beamforming is consistent with this understanding. Embodiments of ping-based beamforming generally involve determining the position of reflectors corresponding to portions of received echo data based on the path along which an ultrasound signal may have
10 traveled, an assumed-constant speed of sound and the elapsed time between a transmit ping and the time at which an echo is received. In other words, ping-based imaging involves a calculation of distance based on an assumed speed and a measured time. Once such a distance has been calculated, it is possible to triangulate the possible positions of any given reflector. This distance calculation is made possible with accurate information about the relative positions of transmit
15 and receive transducer elements (As discussed in Applicants' previous applications referenced above, a multiple aperture probe may be calibrated to determine the acoustic position of each transducer element to at least a desired degree of accuracy.) In some embodiments, ping-based beamforming may be referred to as "dynamic beamforming."

[0054] A dynamic beamformer may be used to determine a location and an intensity for an
20 image pixel corresponding to each of the echoes resulting from each transmitted ping. When transmitting a ping signal, no beamforming need be applied to the transmitted waveform, but dynamic beamforming may be used to combine the echoes received with the plurality of receive transducers to form pixel data.

[0055] The image quality may be further improved by combining images formed by the
25 beamformer from one or more subsequent transmitted pings. Still further improvements to image quality may be obtained by combining images formed by more than one receive aperture. An important consideration is whether the summation of images from different pings or receive apertures should be coherent summation (phase sensitive) or incoherent summation (summing magnitude of the signals without phase information). In some embodiments, coherent (phase
30 sensitive) summation may be used to combine echo data received by transducer elements located on a common receive aperture resulting from one or more pings. In some embodiments, incoherent summation may be used to combine echo data or image data received by receive apertures that could possibly contain cancelling phase data. Such may be the case with receive apertures that have a combined total aperture that is greater than a maximum coherent aperture
35 width for a given imaging target.

[0056] As used herein the terms "ultrasound transducer" and "transducer" may carry their ordinary meanings as understood by those skilled in the art of ultrasound imaging technologies, and may refer without limitation to any single component capable of converting an electrical signal into an ultrasonic signal and/or vice versa. For example, in some embodiments, an
5 ultrasound transducer may comprise a piezoelectric device. In some alternative embodiments, ultrasound transducers may comprise capacitive micromachined ultrasound transducers (CMUT). Transducers are often configured in arrays of multiple elements. An element of a transducer array may be the smallest discrete component of an array. For example, in the case of an array of piezoelectric transducer elements, each element may be a single piezoelectric crystal.

10 [0057] As used herein, the terms "transmit element" and "receive element" may carry their ordinary meanings as understood by those skilled in the art of ultrasound imaging technologies. The term "transmit element" may refer without limitation to an ultrasound transducer element which at least momentarily performs a transmit function in which an electrical signal is converted into an ultrasound signal. Similarly, the term "receive element" may refer without
15 limitation to an ultrasound transducer element which at least momentarily performs a receive function in which an ultrasound signal impinging on the element is converted into an electrical signal. Transmission of ultrasound into a medium may also be referred to herein as "insonifying." An object or structure which reflects ultrasound waves may be referred to as a "reflector" or a "scatterer."

20 [0058] As used herein the term "aperture" refers without limitation to one or more ultrasound transducer elements collectively performing a common function at a given instant of time. For example, in some embodiments, the term aperture may refer to a group of transducer elements performing a transmit function. In alternative embodiments, the term aperture may refer to a plurality of transducer elements performing a receive function. In some embodiments, group
25 of transducer elements forming an aperture may be redefined at different points in time.

[0059] Generating ultrasound images using a ping-based ultrasound imaging process means that images from an entire region of interest are "in focus" at all times. This is true because each transmitted ping illuminates the entire region, receive apertures receive echoes from the entire region, and the dynamic multiple aperture beamforming process may form an image of any part
30 or all of the insonified region. In such cases, the maximum extent of the image may be primarily limited by attenuation and signal-to-noise factors rather than by the confined focus of a transmit or receive beamforming apparatus. As a result, a full-resolution image may be formed from any portion of a region of interest using the same set of raw echo data. As used herein, the term "image window" will be used to refer to a selected portion of an entire insonified region of
35 interest that is being displayed at any given time. For example, a first image window may be

selected to include an entire insonified area, and then a user may choose to "zoom in" on a smaller selected area, thereby defining a new image window. The user may then choose to zoom out or pan the image window vertically and/or horizontally, thereby selecting yet another image window. In some embodiments, separate simultaneous images may be formed of multiple overlapping or non-overlapping image windows within a single insonified region.

Embodiments of Multiple Aperture Ultrasound Imaging Systems & Methods

[0060] Applicant's prior US Patent Application 11/865,501 filed on October 1, 2007, published as US Patent Application Publication 2008/0103393 and US Patent Application 13/029,907 ("the '907 application") describe embodiments of ultrasound imaging techniques using probes with multiple apertures to provide substantially increased resolution over a wide field of view.

[0061] In some embodiments, a probe may include one, two, three or more apertures for ultrasound imaging. FIG. 2 illustrates one embodiment of a multiple aperture ultrasound probe which may be used for ultrasound imaging with a point source transmit signal. The probe of FIG. 2 comprises three transducer arrays 60, 62, 64, each one of which may be a ID, 2D, CMUT or other ultrasound transducer array. In alternative embodiments, a single curved array may also be used, each aperture being defined logically electronically as needed. In still further embodiments, any single-aperture or multiple-aperture ultrasound imaging probe may also be used. As shown, the lateral arrays 60 and 64 may be mounted in a probe housing 70 at angles relative to the center array 62. In some embodiments, the angle Θ of the lateral arrays relative to the central array may be between zero and 45 degrees or more. In one embodiment, the angle Θ is about 30 degrees. In some embodiments, the right and left lateral arrays 60, 64 may be mounted at different angles relative to the center array 62. In some embodiments, the probe 50 of FIG. 2 may have a total width 74 substantially wider than 2cm, and in some embodiments 10 cm or greater.

[0062] In some embodiments as shown in FIG. 2, separate apertures of the probe may comprise separate transducer arrays which may be physically separated from one another. For example, in Figure 2, a distance 72 physically separates the center aperture 62 from the right lateral aperture 64. The distance 72 can be the minimum distance between transducer elements on aperture 62 and transducer elements on aperture 64. In some embodiments, the distance 72 may be equal to at least twice the minimum wavelength of transmission from the transmit aperture. In some embodiments of a multiple aperture ultrasound imaging system, a distance between adjacent apertures may be at least a width of one transducer element. In alternative embodiments, a distance between apertures may be as large as possible within the constraints of a particular application and probe design.

[0063] In some embodiments, a probe such as that illustrated in FIG. 2 may be used with an ultrasound imaging system such as that illustrated in FIG. 1 but omitting the scan converter. As will be described in more detail below, some embodiments of a point-source imaging method negate the need for a scan converter. The probe 50 may also include one or more sensors 52 and/or controllers 54 joined to an ultrasound imaging system and/or to the transducer arrays by cables 56, 57, 58. Embodiments of similar multiple aperture probes 50 are also shown and described in US Patent Application Publication 2010/0262013 and US Patent Application 13/029,907, filed on February 17, 2011, both of which are incorporated herein by reference.

[0064] Embodiments of multiple aperture ultrasound imaging methods using a point-source transmit signal will now be described with reference to FIG. 3. FIG. 3 illustrates a probe 300 with a first aperture 302 and a second aperture 304 directed toward a region of interest represented by the grid below the probe. In the illustrated embodiment, the first aperture is used as a transmit aperture 302, and the second aperture 304 is used for receiving echoes. In some embodiments, an ultrasound image may be produced by insonifying an entire region of interest to be imaged with a point-source transmitting element in a transmit aperture 302, and then receiving echoes from the entire imaged plane on one or more receive elements (e.g., R1 - Rm) in one or more receive apertures 304.

[0065] In some embodiments, subsequent insonifying pulses may be transmitted from each of the elements T1 - Tn on the transmitting aperture 302 in a similar point-source fashion.

Echoes may then be received by elements on the receive aperture(s) 304 after each insonifying pulse. An image may be formed by processing echoes from each transmit pulse. Although each individual image obtained from a transmit pulse may have a relatively low resolution, combining these images may provide a high resolution image.

[0066] In some embodiments, transmit elements may be operated in any desired sequential order, and need not follow a prescribed pattern. In some embodiments, receive functions may be performed by all elements in a receive array 304. In alternative embodiments, echoes may be received on only one or a select few elements of a receive array 304.

[0067] The data received by the receiving elements is a series of echoes reflected by objects within the target region. In order to generate an image, each received echo must be evaluated to determine the location of the object within the target region that reflected it (each reflected point may be referred to herein as a scatterer). For a scatterer point represented by coordinates (ij) in FIG. 3, it is a simple matter to calculate the total distance "a" from a particular transmit element Tx to an element of internal tissue or target object T at (ij), and the distance "b" from that point to a particular receive element. These calculations may be performed using basic trigonometry.

The sum of these distances is the total distance traveled by one ultrasound wave.

[0068] Assuming the speed of the ultrasound waves traveling through the target object is known, these distances can be translated into time delays which may be used to identify a location within the image corresponding to each received echo. When the speed of ultrasound in tissue is assumed to be uniform throughout the target object, it is possible to calculate the time delay from the onset of the transmit pulse to the time that an echo is received at the receive element. Thus, a given scatterer in the target object is the point for which $a+b$ = the given time delay. The same method can be used to calculate delays for all points in the desired target to be imaged, creating a locus of points. As discussed in more detail in the '907 application, adjustments to time delays may be made in order to account for variations in the speed of sound through varying tissue paths.

[0069] A method of rendering the location of all of the scatterers in the target object, and thus forming a two dimensional cross section of the target object, will now be described with reference to FIG. 3 which illustrates a grid of points to be imaged by apertures 302 and 304. A point on the grid is given the rectangular coordinates (ij). The complete image will be a two dimensional array of points provided to a video processing system to be displayed as a corresponding array of pixels. In the grid of FIG. 3, 'mh' is the maximum horizontal dimension of the array and 'mv' is the maximum vertical dimension. FIG. 3 also illustrates MAUI electronics, which can comprise any hardware and/or software elements as needed, such as those described above with reference to FIG. 1.

[0070] In some embodiments, the following pseudo code may be used to accumulate all of the information to be gathered from a transmit pulse from one transmit element (e.g., one element of $T_1 \dots T_n$ from aperture 302), and the consequent echoes received by one receive element (e.g., one element of $R_1 \dots R_m$ from aperture 304) in the arrangement of Figure 3.

[0071]

[0072] for (i = 0; i < mh; i++){

[0073] for (j = 0; j < mv; j++){

[0074] compute distance a

[0075] compute distance b

[0076] compute time equivalent of a+b

[0077] echo[i][j] = echo[i][j]+stored received echo at the computed time delay.

[0078] }

[0079] }

[0080] A complete two dimensional image may be formed by repeating this process for every receive element in a receive aperture 304 (e.g., Rl... Rm). In some embodiments, it is possible to implement this code in parallel hardware resulting in real time image formation.

[0081] In some embodiments, image quality may be further improved by combining similar images resulting from pulses from other transmit elements. In some embodiments, the combination of images may be performed by a simple summation of the single point source pulse images (e.g., coherent addition). Alternatively, the combination may involve taking the absolute value of each element of the single point source pulse images first before summation (e.g., incoherent addition). Further details of such combinations, including corrections for variations in speed-of-sound through different ultrasound paths, are described in Applicant's prior US Patent Applications referenced above.

[0082] As discussed above, because embodiments of an imaging system using a point source transmit signal and a multiple-aperture receive probe are capable of receiving an entire scan-plan image in response to a single insonifying pulse, a scan converter is not needed, and may therefore be omitted from an ultrasound imaging system. Having received a series of image frames in a similar manner, the image data may be processed and sent to a display for viewing by an operator. In addition to ultrasound imaging systems using point-source transmit signals, the following methods of selecting and displaying arbitrary m-mode paths may also be used with any other ultrasound imaging system, including phased array transmit systems, single-aperture probes, 3D probes, and probes in systems using synthetic aperture techniques.

Embodiments for Defining and Displaying Arbitrary M-mode Paths

[0083] FIG. 4A illustrates an example of an ultrasound image with a specified m-mode path 100 drawn through an imaged object 110. The amplitude of each pixel along the m-mode path may be displayed in a graph (e.g. a bar graph, line graph or any other desired format). Changing pixel amplitude values may be illustrated over time. FIG. 4B illustrates an example of a graph of data taken along the m-mode path 100 of FIG. 4A.

[0084] In some embodiments, a sonographer may wish to simultaneously view changes along two or more separate M-mode paths. Thus in some embodiments, a user may define a plurality of M-mode paths 110, 112 as shown in FIG. 5A. The change in pixel values lying along the first and second paths 110, 112 may be displayed simultaneously in a pair of amplitude/time charts as shown for example in FIG. 5B. FIG. 5A also shows an example of a non-linear path 112. As discussed in further detail below, a non-linear M-mode path may have any length and shape as desired.

[0085] Multiple discontinuous M-mode paths and/or non-linear M-mode paths may be beneficial in viewing movement of multiple structures simultaneously. For example, a curve M-mode path may be beneficial when imaging an anatomic structures such as a moving valve, such as a tricuspid valve, an aortic valve or a mitral valve. In other embodiments, multiple

5 simultaneous but dis-continuous m-mode lines may be used to simultaneously view the movement of multiple structures. For example, a first m-mode path may be drawn to view operation of a tricuspid valve, and a second M-mode path may be drawn to view operation of a mitral valve. Viewing the function of both valves simultaneously may provide substantial diagnostic benefits, such as allowing for precise calibration of a pacemaker.

10 [0086] Selection of an M-mode path generally involves identifying a group of image pixel locations which are to be presented over time as an M-mode graph. Identifying a group of pixels for an m-mode path may comprise identifying the coordinates of selected pixels in a coordinate system used by the video processing system. In some embodiments, M-mode selection and display methods as described herein may be performed in real-time using an ultrasound imaging

15 system such as those illustrated in FIGs. 1A and IB. With reference to FIGs. 1A & IB, selection of an M-mode path may be performed by a user via a suitable user interface interaction performed in communication with the M-mode processor 235. The identification of selected pixels may be at least temporarily stored in a memory device associated with the M-mode processor 235. The selected pixels defining the M-mode path may then be retrieved from image

20 frames in the image buffer and/or in the video processor, and an M-mode graph or image illustrating the values of the selected pixels may be formed by the M-mode processor 235 and transmitted to the display to be displayed along with the B-mode image. . In alternative embodiments, M-mode selection and display methods as described herein may be performed on a workstation playing back stored 2D or 3D image data.

25 [0087] In some embodiments, selection of a group of pixel locations for presentation as an M-mode path may be assisted by or entirely performed automatically, such as by using a computer aided detection (CAD) system configured to identify a desired anatomical or other feature through which an m-mode path may be desired. For example, US Patent Application publication 201 1/0021915 describes a system for automatic detection of structures in M-mode

30 ultrasound imaging. In other embodiments, a desired M-mode path may be chosen by a user through any of several possible user interface interactions, several examples of which are provided below.

[0088] As will be clear to the skilled artisan, an imaging system or an image display system may include a variety of user interface devices through which a user may input information to or

35 modify information or objects in a displayed image. Such user interface devices may comprise

any of the following, trackballs, buttons, keys, keypads, sliders, dials, voice commands, touch screen, joystick, mouse, etc. The use of these and other user input devices will be clear to the skilled artisan.

5 [0089] In some embodiments, any arbitrary line or path in the image plane may be selected by a user as a line for M-mode display. In some embodiments, a linear path of defined length may be selected as an m-mode path. This may be facilitated through a number of user interface interactions, some examples of which are provided below.

10 [0090] In some embodiments, the ultrasound display may include a touch screen, and a user may define an M-mode path by simply drawing the desired path with a finger or stylus directly on the display screen. In other embodiments, a user may draw a freehand path using a separate user interface device such as a mouse or a drawing tablet. In some embodiments, after drawing a path of a desired shape, an M-mode path of the desired shape may be dragged across a display and/or rotated to a desired position.

15 [0091] In one embodiment of a user interface interaction, a linear m-mode path segment may be selected by first defining a line length, then defining a rotation angle, and then translating the line into a desired position. In some embodiments, further adjustments to the line length, rotation angle, and position may be made as needed. In some embodiments, defining a line length may comprise entering a numeric value with a numeric keypad or increasing/decreasing a numeric line length value with a scroll wheel, track ball, dial, slider, arrow keys or other input device. Similarly, in some embodiments, a rotation angle may be defined by entering a numeric value with a numeric keypad or any other input device. A rotation angle may be defined relative to any suitable coordinate system. For example, in some embodiments, a rotation angle of zero degrees may correspond to a three o'clock position (e.g., assuming the top of the image is 12 o'clock).

25 [0092] In some embodiments, numeric values of line length or rotation angle may not be displayed, instead only changes to a line length or rotation angle of the line may be shown on the display screen. In some embodiments, translating the line up, down, left or right within the image plane may be performed using arrow keys, a track ball, a mouse, touch screen, voice commands or other input devices.

30 [0093] In another embodiment of a user interface interaction, a desired linear m-mode path segment may be selected by defining or adjusting a line length, translating the line until a first end point is in a desired position, fixing the first end point and rotating the second end point until the line is rotated to the desired orientation and position.

35 [0094] In another embodiment of a user interface interaction, a desired linear m-mode path segment may be selected by first selecting a first end point, such as by positioning a cursor at a

desired position on the image. A line length and rotation angle may then be defined and adjusted as needed. In some embodiments, a rotation angle may be defined by directing the system to pivot the line about the selected first end point. Alternatively, a user may select the second end point or another point along the line about which to pivot the line in order to define a desired rotation angle.

[0095] In another embodiment of a user interface interaction, a desired linear m-mode path segment may be selected by selecting a first end point with a cursor and then dragging the cursor in a desired direction to draw a line. In other embodiments, a line may be defined by selecting first and second end points, defining a line by joining the two points.

[0096] In any case, once a line is defined, either automatically or through a user interface interaction such as those described above, the length and rotation angle may be adjustable through further user interface interactions. For example, a user may define a pivot point about which to pivot the line in order to adjust a rotation angle. Similarly, a user may select a fixed point from which to increase or decrease the length of the line. Such fixed points and pivot points may be either one of the end points, or any other point along the line.

[0097] In some embodiments, a non-linear M-mode path may be defined through any of the above user interface interactions by joining linear segments to form any desired non-linear path made up of linear segments. In some embodiments, a user may choose to apply a radius to the M-mode path in areas adjacent intersections of linear segments. In some embodiments, such a radius may be applied automatically, or may be increased or decreased through a user interface interaction.

[0098] In other embodiments, a non-linear M-mode path may be defined by providing a user with a free-form drawing cursor with which the user may draw any non-linear path as desired. Further adjustments may then be made to the path, such as by selecting and dragging one or more individual points along the path to obtain a desired M-mode path.

[0099] As described above, multiple images may be formed for two or more separate simultaneous image windows showing different overlapping or non-overlapping portions of an insonified region of interest. Thus, in some embodiments, an M-mode path may be defined while a first image window is displayed, and a user may then zoom or pan the image to a second image window. In some embodiments, the system may be configured to continue displaying the data along the defined M-mode path even when the displayed B-mode image is changed to a different image window than the one in which the M-mode path was defined. For example, a user may zoom in to view a heart valve, and may define an M-mode path intersecting the valve in the zoomed-in image window. The user may then choose to zoom out to view the movement of the

whole heart (or a different region of the heart) while continuing to monitor data along the M-mode line intersecting the heart valve.

[00100] In some embodiments, the system may store a definition of the image window in which the M-mode line was defined, and may allow a user to toggle between a B-mode image of the M-mode defining image window and a B-mode image of at least one other image window. In still further embodiments, the system may be configured to simultaneously display B-mode images of both the M-mode defining window and another image window (e.g., in a picture-in-picture mode or in a side-by-side view).

[00101] Any of the above user interface interactions may also be used to define an M-mode path through a displayed 3D volume. In some embodiments, defining an M-mode path from a 3D volume may also involve a step of rotating an image of a 3D volume before after or during any of the M-mode path defining user interface steps described above.

[00102] Although various embodiments are described herein with reference to ultrasound imaging of various anatomic structures, it will be understood that many of the methods and devices shown and described herein may also be used in other applications, such as imaging and evaluating non-anatomic structures and objects. For example, the ultrasound probes, systems and methods described herein may be used in non-destructive testing or evaluation of various mechanical objects, structural objects or materials, such as welds, pipes, beams, plates, pressure vessels, layered structures, etc. Therefore, references herein to medical or anatomic imaging targets such as blood, blood vessels, heart or other organs are provided merely as non-limiting examples of the nearly infinite variety of targets that may be imaged or evaluated using the various apparatus and techniques described herein.

[00103] Although this invention has been disclosed in the context of certain preferred embodiments and examples, it will be understood by those skilled in the art that the present invention extends beyond the specifically disclosed embodiments to other alternative embodiments and/or uses of the invention and obvious modifications and equivalents thereof. Thus, it is intended that the scope of the present invention herein disclosed should not be limited by the particular disclosed embodiments described above, but should be determined only by a fair reading of the claims that follow. In particular, materials and manufacturing techniques may be employed as within the level of those with skill in the relevant art. Furthermore, reference to a singular item, includes the possibility that there are plural of the same items present. More specifically, as used herein and in the appended claims, the singular forms "a," "and," "said," and "the" include plural referents unless the context clearly dictates otherwise. It is further noted that the claims may be drafted to exclude any optional element. As such, this statement is intended to serve as antecedent basis for use of such exclusive terminology as "solely," "only" and the like in

connection with the recitation of claim elements, or use of a "negative" limitation. Unless defined otherwise herein, all technical and scientific terms used herein have the same meaning as commonly understood by one of ordinary skill in the art to which this invention belongs.

CLAIMS

What is claimed is:

1. A method of defining and displaying an m-mode path for display in an ultrasound imaging system, the method comprising:
 - transmitting an ultrasound signal from a transmitting transducer element into a region of
 - 5 interest including a structure of interest;
 - receiving echoes with at least one receiving transducer element;
 - producing an image of the region of interest from the received echoes;
 - displaying the image of the region of interest including the structure of interest to a user;
 - defining a one-pixel-wide path through the structure of interest, where the path does not
 - 10 lie along a line that intersects the transmitting transducer element or the receiving transducer element; and
 - displaying a graph of a magnitude of pixels along the path over time.
2. The method of Claim 1, wherein the path is non-linear.
- 15 3. The method of Claim 2, wherein the path has at least one curved segment.
4. The method of Claim 1, wherein the path has at least one linear segment and at least one curved segment.
- 20 5. The method of Claim 2, wherein the path has at least two linear segments that intersect at an angle other than 180 degrees.
6. The method of Claim 1, wherein the path has at least two dis-continuous segments.
- 25 7. The method of Claim 1, wherein the transmitting transducer element lies on a separate physical transducer array from an array containing the at least one receiving transducer element.
8. The method of Claim 7, wherein the transmitting transducer is configured to transmit an
- 30 un-focused ping ultrasound signal into the region of interest.
9. The method of Claim 8, further comprising receiving echoes from the entire region of interest with the at least one receiving transducer element, receiving echoes from the entire

region of interest with a second receiving transducer element, and producing an image of the region of interest by combining echoes received at the first and second transducer elements.

10. The method of Claim 1, wherein defining a path through the structure of interest is performed substantially concurrently with said transmitting and receiving.
11. The method of Claim 1, wherein the transmitting transducer is configured to insonify a phased array scan line.
12. A method of ultrasound imaging, comprising:
transmitting ultrasound signals into a region of interest and receiving echoes of the transmitted ultrasound signals with an ultrasound probe;
defining a first image window as a portion of the region of interest;
identifying an M-mode path intersecting a feature visible in the first image window;
displaying data representing the M-mode path on a common display with a B-mode image of the first image window;
defining a second image window as a portion of the region of interest that is different than the first image window; and
displaying the data representing the M-mode path on a common display with a B-mode image of the second image window.
13. The method of Claim 12, wherein all of the method steps are performed during a live real-time imaging session.
14. The method of Claim 12, wherein the M-mode path includes at least one non-linear segment.
15. The method of Claim 12, wherein the M-mode path is not a line intersecting the probe.
16. The method of Claim 12, wherein all of the method steps are performed using stored raw echo data retrieved from a raw data memory device.
17. The method of Claim 12, wherein the first image window is smaller than and lies entirely within the second image window.

18. The method of Claim 12, wherein the second image window does not overlap the first image window.

19. The method of Claim 12, further comprising simultaneously displaying the data of the M-mode path on a common display with B-mode images of both the first image window and the second window.

20. The method of Claim 12, wherein the M-mode path has at least two discontinuous segments.

10

21. A multi-aperture M-mode ultrasound imaging system, comprising:

a transmitting transducer element configured to transmit an ultrasound signal into a region of interest including a structure of interest;

15 a receiving transducer element separate from the transmitting transducer element, the receiving transducer element configured to receive echoes from the ultrasound signal;

a controller configured to produce an image of the region of interest from the received echoes;

20 an input mechanism configured to receive a user input defining a one-pixel-wide path through the structure of interest, where the path does not lie along a line that intersects the transmitting transducer element or the receiving transducer element; and

a display configured to display the region of interest including the structure of interest, the display also configured to display a graph of a magnitude of pixels along the path over time.

22. The system of claim 21 wherein the transmitting transducer is configured to transmit an unfocused ping ultrasound signal into the region of interest.

23. The system of claim 21 wherein the transmitting transducer is configured to transmit an unfocused spherical ping ultrasound signal into the region of interest.

30 24. The system of claim 21 wherein the transmitting transducer is configured to insonify a phased array scan line.

Fig. 1A

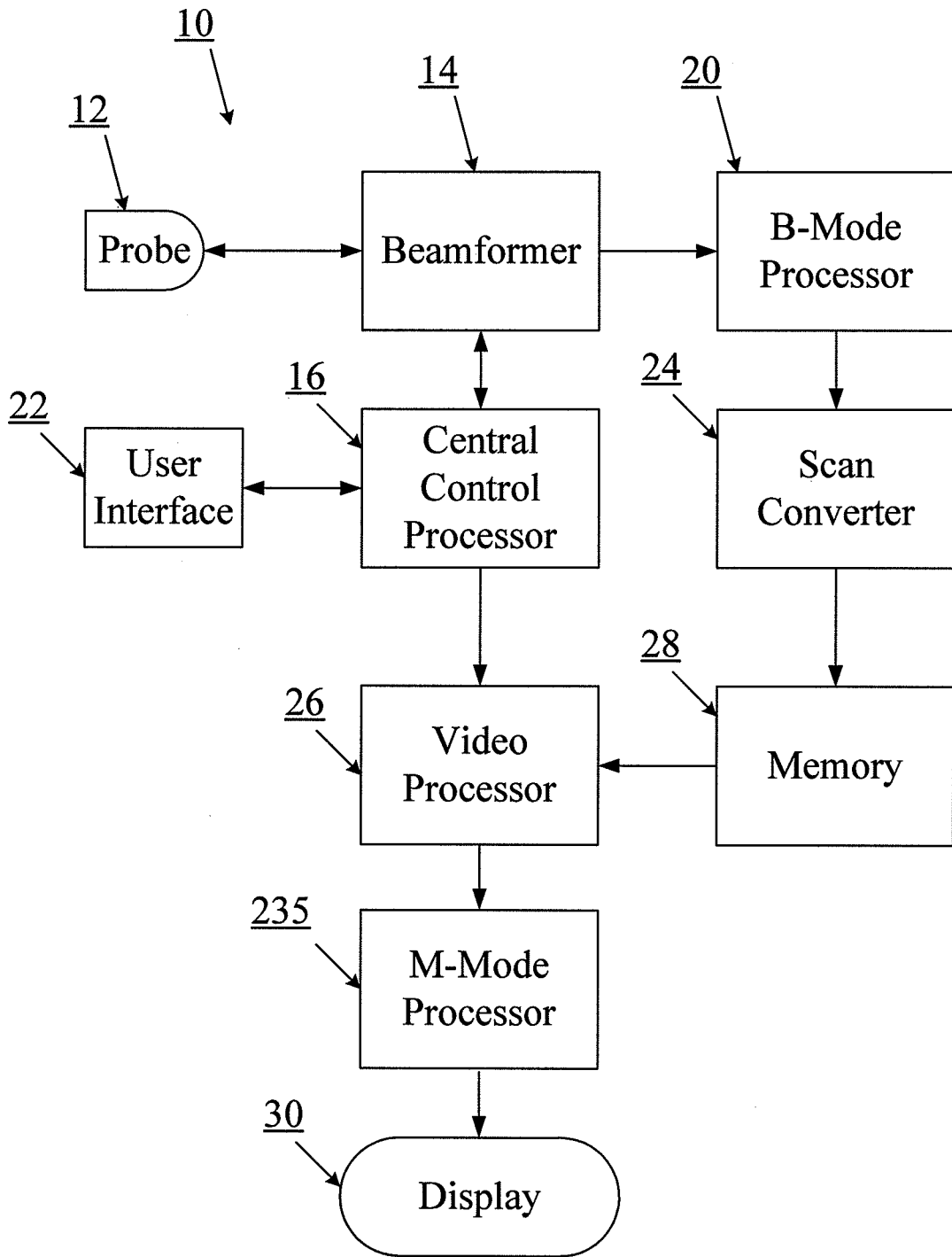

Fig. 1B

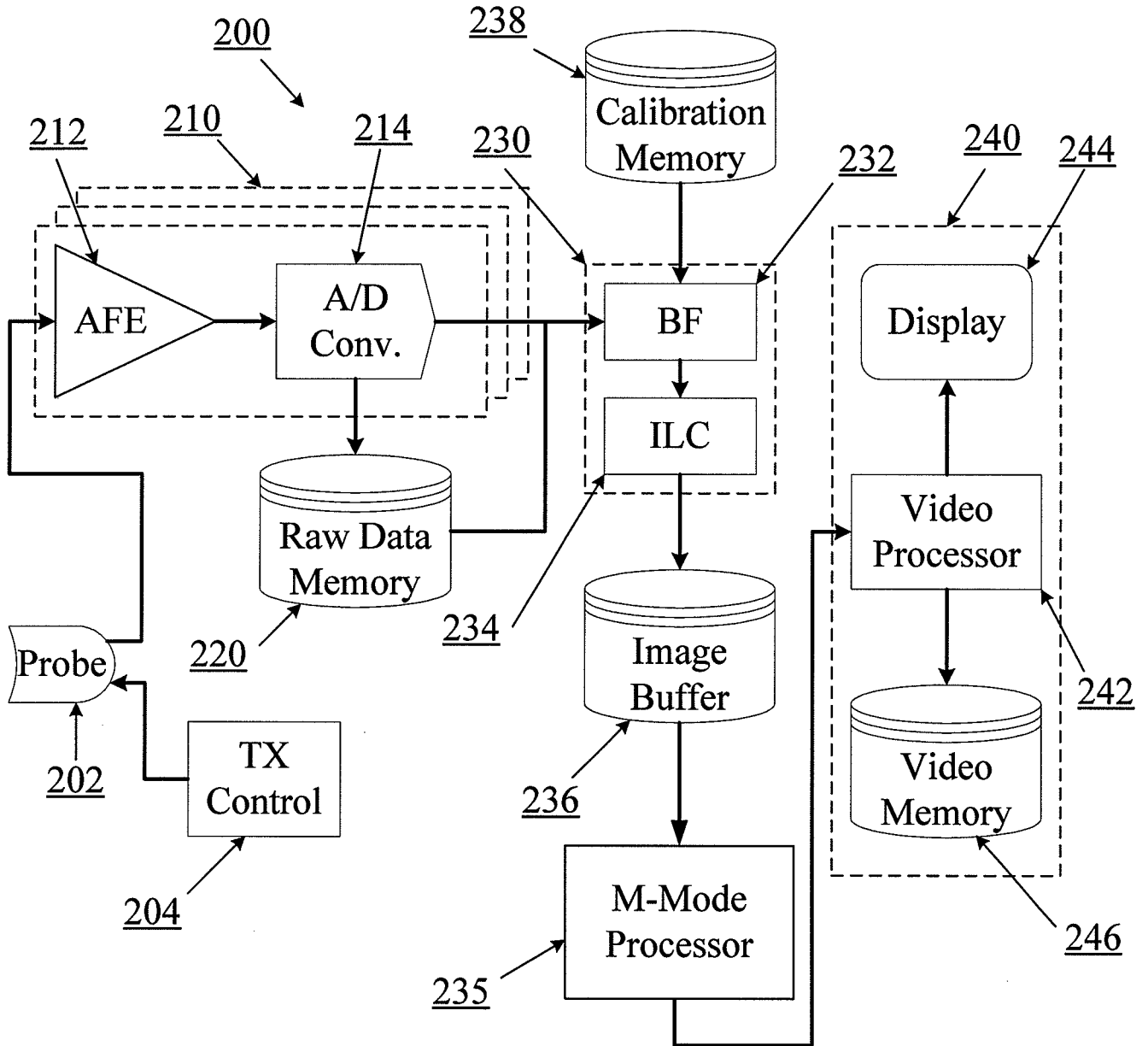

Fig. 2

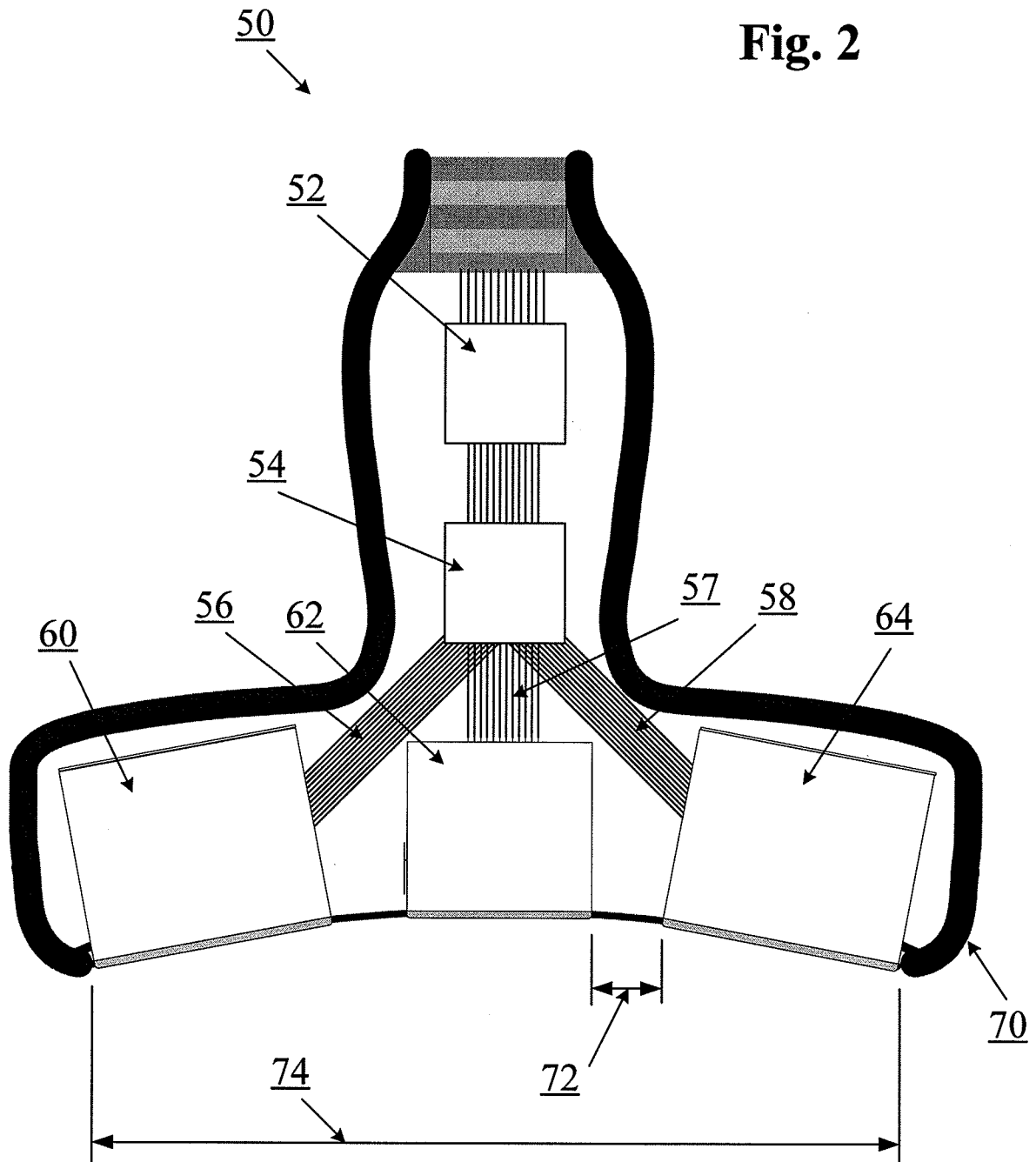
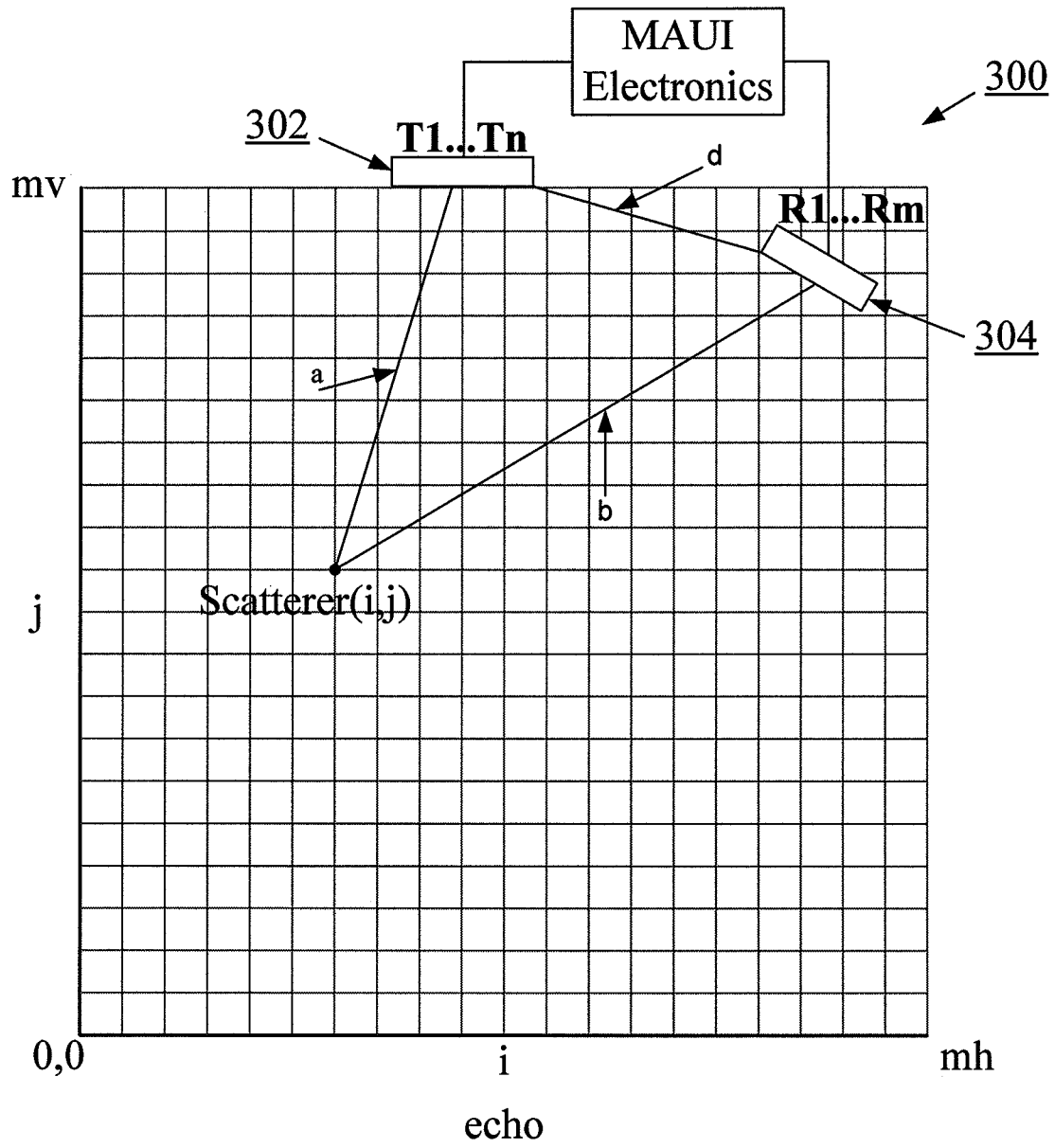

Fig. 3



5/6

Fig. 4A

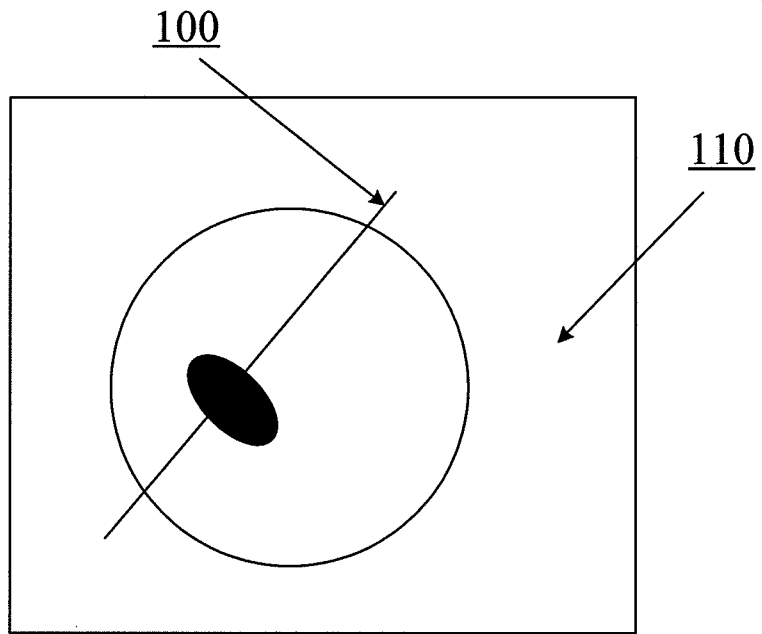
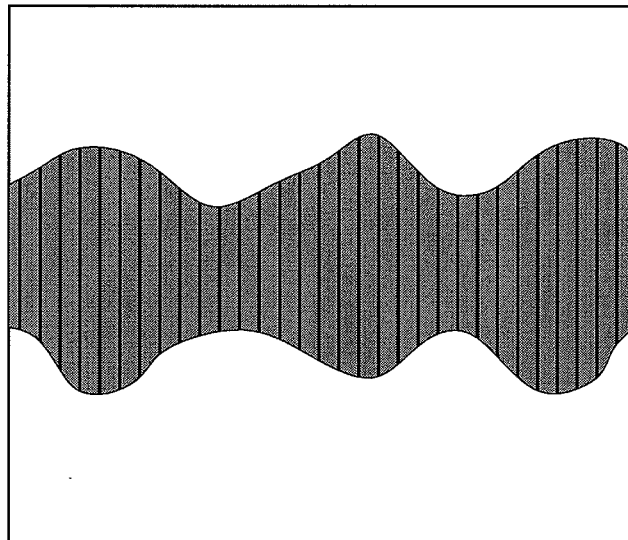

Fig. 4B



6/6

Fig. 5A

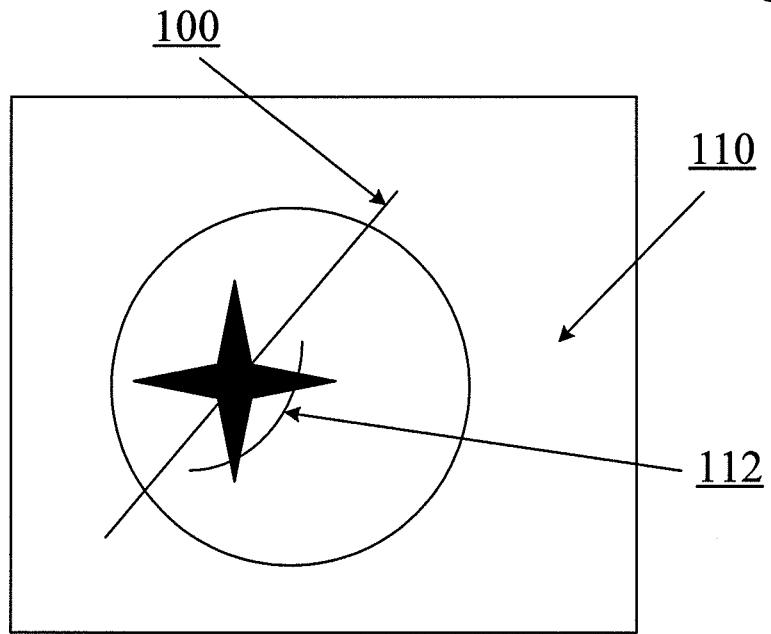
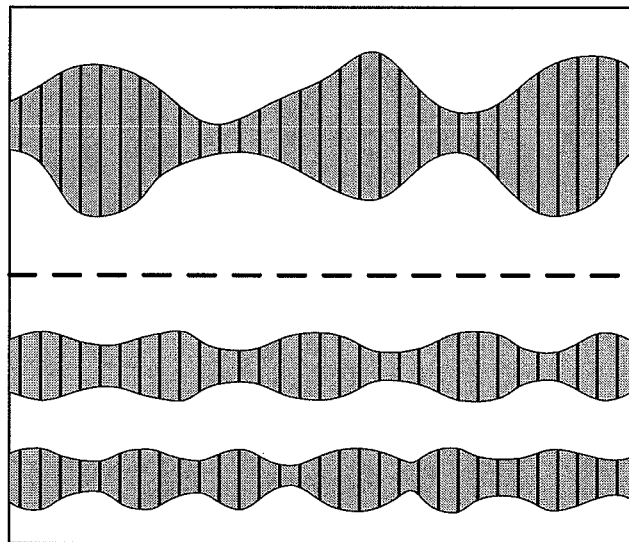

Fig. 5B



INTERNATIONAL SEARCH REPORT

International application No.
PCT/US2012/071923**A. CLASSIFICATION OF SUBJECT MATTER****A61B 8/00(2006.01)i, G01N 29/24(2006.01)I, G06T 7/20(2006.01)I**

According to International Patent Classification (IPC) or to both national classification and IPC

B. FIELDS SEARCHED

Minimum documentation searched (classification system followed by classification symbols)

A61B 8/00; G01N 29/22; A61B 8/14

Documentation searched other than minimum documentation to the extent that such documents are included in the fields searched

Korean utility models and applications for utility models

Japanese utility models and applications for utility models

Electronic data base consulted during the international search (name of data base and, where practicable, search terms used)

eKOMPASS(KIPO internal) & Keywords: ultrasound, m-mode, b-mode, path, display, graph, zoom

C. DOCUMENTS CONSIDERED TO BE RELEVANT

Category *	Citation of document, with indication, where appropriate, of the relevant passages	Relevant to claim No.
X Y A	US 2006-0173327 AI (JEONG HWAN KIM) 03 August 2006 See abstract, paragraphs [0022] -[0041], claims 1-5 and figures 2, 4A-7.	1, 10 2-9, 11, 21-24 12-20
Y	US 2004-0111028 AI (YASUHIKO ABE et al.) 10 June 2004 See abstract, paragraphs [0032], [0043] -[0047], [0068] -[0088], [0106] -[0107], claim 1 and figures 1-15.	2-6
Y	US 2010-0262013 AI (DAVID M. SMITH et al.) 14 October 2010 See abstract, paragraphs [0021], [0076] -[0084], claims 1, 20-22 and figures 1, 5-6c.	7-9, 11, 21-24
A	US 2009-0012393 AI (SEOK WON CHOI) 08 January 2009 See abstract, paragraphs [0015] -[0028], claims 1-8 and figures 1-6.	1-24
A	JP 08-252253 A (HITACHI MEDICAL CORP.) 01 October 1996 See abstract, paragraphs [0010] -[0018], [0023] -[0033], claims 1-2 and figures 1-3.	1-24

 Further documents are listed in the continuation of Box C. See patent family annex.

* Special categories of cited documents:

"A" document defining the general state of the art which is not considered to be of particular relevance

"E" earlier application or patent but published on or after the international filing date

"L" document which may throw doubts on priority claim(s) or which is cited to establish the publication date of citation or other special reason (as specified)

"O" document referring to an oral disclosure, use, exhibition or other means

"P" document published prior to the international filing date but later than the priority date claimed

"T" later document published after the international filing date or priority date and not in conflict with the application but cited to understand the principle or theory underlying the invention

"X" document of particular relevance; the claimed invention cannot be considered novel or cannot be considered to involve an inventive step when the document is taken alone

"Y" document of particular relevance; the claimed invention cannot be considered to involve an inventive step when the document is combined with one or more other such documents, such combination being obvious to a person skilled in the art

"&" document member of the same patent family

Date of the actual completion of the international search

26 April 2013 (26.04.2013)

Date of mailing of the international search report

30 April 2013 (30.04.2013)

Name and mailing address of the ISA/KR

 Korean Intellectual Property Office
 189 Cheongsu-ro, Seo-gu, Daejeon Metropolitan
 City, 302-70 1, Republic of Korea

Facsimile No. 82-42-472-7140

Authorized officer

KIM, Tae Hoon

Telephone No. 82-42-481-8407



INTERNATIONAL SEARCH REPORT

International application No.

PCT/US2012/071923

C (Continuation). DOCUMENTS CONSIDERED TO BE RELEVANT		
Category *	Citation of document, with indication, where appropriate, of the relevant passages	Relevant to claim No.
A	US 2011-0021915 A1 (SHAOLEI FENG et al.) 27 January 2011 See abstract , paragraphs [0021H0025] , [0035]-[0036] , claims 1-18 and figures 1-6.	1-24

INTERNATIONAL SEARCH REPORT

Information on patent family members

International application No.

PCT/US2012/071923

Patent document cited in search report	Publication date	Patent family member(s)	Publication date
US 2006-0 173327 A 1	03,08,2006	EP 1679038 A2 EP 1679038 A3 JP 2006- 187594 A KR 10-0748 178 B1 KR 10-2006-0080346 A	12.07.2006 13.04.2011 20.07.2006 09.08.2007 10.07.2006
us 2004-0 111028 A 1	10,06,2004	JP 2004-073287 A JP 4202697 B2 US 6884216 B2	11.03.2004 24.12.2008 26.04.2005
us 2010-02620 13 A 1	14,10,2010	EP 2419023 A2 KR 10-2011-0137829 A Wo 2010-120913 A2	22.02.2012 23.12.2011 21.10.2010
us 2009-00 12393 A 1	08,01,2009	EP 1972280 A1 JP 2008-237909 A KR 10-1055589 B1 KR 10-2008-0086578 A	24.09.2008 09.10.2008 23.08.2011 26.09.2008
JP 08-252253 A	01,10,1996	JP 3612358 B2	19.01.2005
us 2011-00219 15 A 1	27,01,2011	US 8343053 B2	01.01.2013