

(19) World Intellectual Property Organization  
International Bureau



(43) International Publication Date  
17 May 2001 (17.05.2001)

PCT

(10) International Publication Number  
WO 01/35376 A1

- (51) International Patent Classification<sup>7</sup>: **G09B 19/00** **Michael** [—/US]; 118 Bluff Park Circle, Austin, TX 78746 (US).
- (21) International Application Number: PCT/US00/31253
- (22) International Filing Date: 10 November 2000 (10.11.2000)
- (25) Filing Language: English
- (26) Publication Language: English
- (30) Priority Data:
 

60/165,056	12 November 1999 (12.11.1999)	US
09/440,557	15 November 1999 (15.11.1999)	US
- (71) Applicant (for all designated States except US): **RE-CARE, INC.** [US/US]; Suite 207, 9801 Anderson Mill Road, Austin, TX 78750 (US).
- (72) Inventors; and
- (75) Inventors/Applicants (for US only): **LIPSCHER, Randolph** [—/US]; 12349 Metric Boulevard #1524, Austin, TX 78758 (US). **GRIFFIN, Christopher** [—/US]; 2003 Kenwood Avenue, Austin, TX 78704 (US). **DAHLIN,**
- (74) Agent: **RUSSELL, Douglas, D.**; Taylor Russell & Russell, P.C., Building One, Suite 1200, 4807 Spicewood Springs Road, Austin, TX 78759 (US).
- (81) Designated States (national): AE, AL, AM, AT, AU, AZ, BA, BB, BG, BR, BY, CA, CH, CN, CR, CU, CZ, DE, DK, DM, DZ, EE, ES, FI, GB, GD, GE, GH, GM, HR, HU, ID, IL, IN, IS, JP, KE, KG, KP, KR, KZ, LC, LK, LR, LS, LT, LU, LV, MA, MD, MG, MK, MN, MW, MX, MZ, NO, NZ, PL, PT, RO, RU, SD, SE, SG, SI, SK, SL, TJ, TM, TR, TT, TZ, UA, UG, US, UZ, VN, YU, ZA, ZW.
- (84) Designated States (regional): ARIPO patent (GH, GM, KE, LS, MW, MZ, SD, SL, SZ, TZ, UG, ZW), Eurasian patent (AM, AZ, BY, KG, KZ, MD, RU, TJ, TM), European patent (AT, BE, CH, CY, DE, DK, ES, FI, FR, GB, GR, IE, IT, LU, MC, NL, PT, SE, TR), OAPI patent (BF, BJ, CF, CG, CI, CM, GA, GN, GW, ML, MR, NE, SN, TD, TG).

Published: — With international search report.

[Continued on next page]

(54) Title: ELECTRONIC HEALTHCARE INFORMATION AND DELIVERY MANAGEMENT SYSTEM

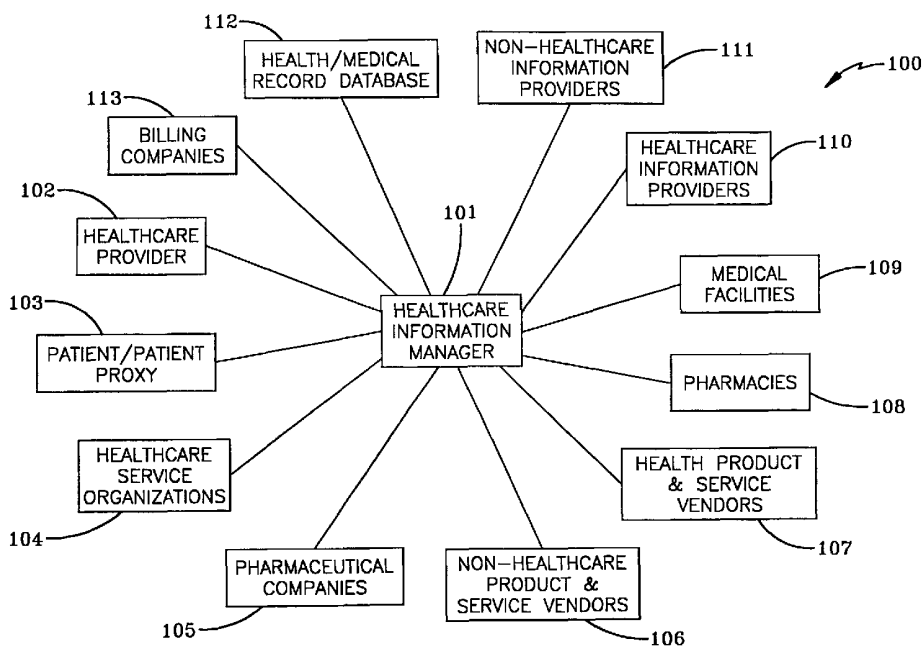

(57) Abstract: A computer system (100) and computer implemented method for displaying targeted healthcare advertisements to a computer user. The system comprises an advertising selecting computer (101), a plurality of devices (102-112) for enabling entry of healthcare related information, a database for storing the healthcare related information and advertising information connected to the advertising selecting computer. A communications network transmits the healthcare related information from the devices to the selecting computer for storage in the database.

WO 01/35376 A1



---

*For two-letter codes and other abbreviations, refer to the "Guidance Notes on Codes and Abbreviations" appearing at the beginning of each regular issue of the PCT Gazette.*



physician practice tools. None of these systems take into account long-standing patterns of practice by physicians. Physicians do not practice medicine while sitting in front of a desktop or laptop computer. Physicians are long accustomed to moving from patient to patient, room to room, creating the  
5 medical record on clipboards as they go, writing prescriptions on small pads they can easily carry. Handheld physician practice tools include devices that must be physically connected (“docked”) to a device or network for information to be transferred to the Internet or to a central computer. Other handheld devices rely on infrared wireless connections that force the user to  
10 point the handheld device at an infrared port on a base station, printer, or other fixed device for information to be transferred. Handheld devices often have small screens, black-and-white or grayscale displays, and poor resolution.

Around 1993, people began to look to a global communications  
15 network (known as the Internet) as a way to further streamline several aspects of medical practice including medical records, prescription writing and delivery, lab ordering, insurance verification and billing. The Internet offers a low-cost, universally available platform for creating, accessing, and delivering data in a manner that can be user-friendly, has multiple levels of access from  
20 multiple locations, and can deliver data in any number of formats. Computer applications that perform one or more of these aforementioned tasks using the Internet currently exist.

However, current Internet-enabled technologies still have drawbacks and have not been readily adopted in the healthcare industry. First, it has

proven difficult to convince physicians to adopt new technology. Physicians are not likely to respond to a new technology lacking any significant economic or timesaving benefits. They are also not responsive to technology and systems that significantly alter their established patterns of behavior. In addition, many Internet medical websites are geared towards providing information to the patient rather than being focused on the physician.

Second, even though patients have begun to seek out their own health and medical information using the Internet in an attempt to become more active participants in their own health care provisioning as part of a larger trend of utilizing the Internet to gather all types of information, the credibility of the information available on the Internet is of concern. The consumer usually prefers to obtain health care information directly from his or her physicians.

Third, current Internet services and products for physicians and patients have not been integrated solutions. Some simply provide health care information or referral services. Others focus on solving a problem in a single aspect of a physician's practice, such as billing, writing prescriptions or managing patient records. The challenge here is getting physicians to assist in building these online record repositories and to use the billing and prescription writing systems because many of these systems require physicians to alter their established patterns of behavior.

Another reason that Internet-enabled technologies have been slow to be adopted by the physician is that in the typical business model, the physician pays for the technology. Managed care has resulted in a decline in income for many physicians. Because of this, physicians must see more

patients, which results in little time to learn about and purchase new technology.

In the area of prescriptions, pharmaceutical companies spend billions of dollars in total advertising. A large portion of this advertising budget is  
5 spent for detailing, which is the interaction between the pharmaceutical industry and physicians to influence physician prescribing habits. Much of this advertising includes personal visits by a pharmaceutical representative to the physician, advertisements in medical journals, and pharmaceutical advertisements on paper prescription pads. Due to the increased lack of time  
10 that physicians have to spend with representatives (in part due to the forces of managed care), such advertising in journals and on prescription pads has become one of the strongest forms of pharmaceutical promotions. Recently, one company has put computer screens in physician offices to provide, among other features, advertising. But again, the vast majority of physicians  
15 don't look at a news service while they are writing prescriptions; they look at a prescription pad. As far as prescriptions are concerned, the prescription pad is the de facto point of sale.

Companies offering physician management systems usually charge the physician or physician practice group for their products. One problem with  
20 this traditional payment model is that in addition to being reluctant to use a new technology, physicians may be reluctant to pay for new technology because of decreased profit margins due to the rise of managed care.

What is needed is a business model in which revenue can be generated from sources other than the physician so that the healthcare information and

delivery management system can be provided at free or at low cost to the physician user. Health care product suppliers, such as pharmaceutical companies, have the incentive and resources to pay for physician management systems. In addition to having less time to spend with their patients, physicians also have less time to spend meeting with health care product suppliers such as pharmaceutical representatives and reading their marketing materials. But healthcare product suppliers still need to get information about their products to the people who prescribe and recommend their products—the physicians themselves.

10 What is also needed is a system that is designed to function in a manner consistent with the way physicians practice medicine. Such a system would be mobile, contain task automation tools, and have the ability to collect data from various sources such as the patient, staff members, and healthcare providers. It should also have the ability to streamline various processes such as medical record creation, prescription writing and pharmacy selection. If the system is connected to a local or global communications network, the connection should be seamless and not require extra steps on the part of the user to transmit and receive data.

20 Current systems do not offer a method for directing patient specific health care information and health care product information to physicians at specific points in a physician's work cycle, such as prescription writing or performing a physical assessment of a patient. Healthcare information is available to the physician in medical journals, but it is not presented to the physician while he or she is with a patient. Nor is it targeted to the condition and symptoms of the

patient being seen by the physician. Healthcare product advertisements are also included in those journals and are separately sent to physicians. As discussed above, some types of advertisements such as pharmaceutical advertisements, are also presented within paper prescription pads, on patient  
5 history forms and on other products used by physicians. These are also not directly linked to the conditions, histories, and medications of the individual patients and may not be readily available to the physician while treating a patient.

It would be desirable to develop a new model for directing patient specific  
10 health care information and health care product information to physicians at specific points in a physician's work cycle, such as prescription writing or doing a physical assessment. The health care information and product information should be selected based on patient criteria such as the patient's age, gender, past medical history, current complaint, condition, allergies,  
15 current medications or formulary restrictions. The information advertisements may also be selected based on physician criteria such as medical specialty, geographic area or past prescribing history.

Physician information management systems do not allow direct patient input of information into the system. The result is that much time is spent  
20 collecting information from patients via paper-based questionnaires and verbal encounters. This information must then be entered into current computer systems by staff and/or physicians themselves.

What is needed is a system that allows direct patient and staff input (and/or proxy input) of information into the system. This information may then



be automatically mapped onto the appropriate form for physician review, editing, and confirmation. The questions presented to the patient may use less technical terminology, while the patients' answers could be converted into more precise medical language for the physician. Such a system would  
5 increase operational efficiency and save time and effort currently wasted on reprocessing data gathered on paper-based forms or from verbal interviews.

Patients may currently gather health information by searching health related Internet websites. To some extent, the patient can customize a site after logging onto a website. One problem with this traditional Internet model  
10 is that since the user's interests are not immediately addressed upon login and the user must then actively customize his or her own screen, the user may not continue to visit and use the website. Since advertisers pay revenues to websites often based on the number of visitors and users, this can result in less revenue to the website.

15 It would be desirable to change this traditional Internet model to develop a system of website "preemptive customization" for health care patients along with traditional site customization by the user. Such a system would use data electronically collected elsewhere (such as at the medical kiosk or other device in the physician's office) to "preemptively customize" a patient's Web  
20 site before he or she ever actually logs onto the site. From the moment the user logs onto the site, health care information, products, services, and advertising can be targeted to address the needs and interests of the user. Such a system should dramatically increase the "stickiness" of the Web site, since patients' interests would be addressed immediately upon login, rather

than after going through a traditional customization scenario. Users could further customize their sites according to traditional methods.

Present health care information and management systems lack the ability to provide integrated health care and product information to small groups or  
5 even specific individuals via the Internet that can target physicians and their patients in a highly targeted and coordinated manner. What is needed is a system able to synchronize health care and product information and advertising directed to groups and specific individuals via the Internet.

#### SUMMARY

10 The present invention solves the aforementioned problems and needs.

The present system and method provides a computer-implemented method in which revenue can be generated from sources other than the physician so the healthcare information and delivery management system can be provided at free or at low cost to the physician user. The present system  
15 and method provides a computer-implemented system that is designed to function in a manner consistent with the way physicians practice medicine. It allows for user mobility, contains task automation tools and has the ability to collect data that is input from various sources such as the patient, staff members, and healthcare providers. It has the ability to streamline various  
20 processes such as medical record creation, prescription writing and pharmacy selection. The system may be connected to a local or global communications network, providing a seamless connection that does not require extra steps on the part of the user to transmit and receive data.

The present system offers a computer-implemented method for directing patient specific health care information and health care product information to physicians at specific points in a physician's work cycle, such as prescription writing or performing a physical assessment of a patient.

5 Healthcare information is presented to the physician while he or she is with a patient. The information is targeted to the condition and symptoms of the patient. Healthcare product information and advertisements, including pharmaceutical advertisements, are displayed by the healthcare information management system and are directly linked to the conditions, histories, and  
10 medications of the individual patients and are readily available to the physician while treating a patient. The system is able to synchronize health care and product information and advertising and direct it to groups and specific individuals via the Internet.

The present system and method includes a business model in which  
15 revenue can be generated from sources other than the health care provider so the healthcare information and delivery management system can be provided at free or at low cost to the health care provider user. Health care product advertisers can supply the system to the health care provider and/or their patients, which enables the advertisers to communicate directly with  
20 health care providers and their patients. In addition, health care providers could receive revenues from using the system, for example payments for viewing health care product information and advertisements or using advertised products and services.

The present invention encompasses a computer-implemented method for directing patient-specific healthcare information and healthcare product information to physicians at specific points in a physician's work cycle, such as prescription writing or doing a physical assessment. The health care information and product information that is selected to be displayed by the system is based on patient criteria such as the patient's age, gender, past medical history, current complaint, condition, allergies, current medications or formulary restrictions. The information and advertisements may also be selected for display by the system based on physician criteria such as medical specialty, geographic area or past prescribing history.

The system allows for direct patient input of information into the system to reduce healthcare provider time spent collecting information from patients via paper-based questionnaires and verbal encounters. This information is automatically entered into computer systems to form a patient record and to document patient preferences, such as pharmacy of choice and preferred healthcare products. The system also allows direct staff input of information into the system. This information is then automatically mapped onto the appropriate form for physician review, editing, and confirmation. This information then becomes part of the medical record. The system increases operational efficiency and saves time and effort currently wasted on reprocessing data gathered on paper-based forms or from verbal interviews.

The system and method allows for websites to be preemptively customized for health care patients along with traditional site customization by the user. The system uses data electronically collected elsewhere (such as at

the medical kiosk or other device in the physician's office) to customize a patient's Web site before he or she ever actually logs onto the site. From the moment the user logs onto the site, health care information, products, services, and advertising can be targeted to address the needs and interests  
5 of the user. Users can further customize their sites according to traditional methods.

An example of a method of using the present system and method follows. A patient arrives at a physician's office and enters the appropriate information into the medical kiosk or other device in the front office. From this  
10 information, this system learns that the patient is allergic to penicillin and penicillin derivatives. When the physician examines the patient, he diagnoses strep pharyngitis. For a non-allergic patient, penicillin might be a recommended treatment option so an advertisement for such could be displayed. However, the system takes the patient's history and conditions into  
15 account so for this penicillin-allergic patient all advertisements for penicillin-based products are excluded from display. For this patient, an advertisement for erythromycin might be displayed. Knowing the physician's prescribing habits which have been saved by the system, the brand of drug that is most often prescribed by this physician or an advertisement for a drug that directly  
20 competes with the drug most often prescribed by this physician may be displayed. This capability allows companies to advertise pharmaceuticals marketed against established products.

The present invention is a computer system for displaying targeted healthcare information to a computer user comprising a healthcare product

information selecting computer, a plurality of devices for enabling entry of healthcare related information into the system, a database for storing the healthcare related information and healthcare product information connected to the healthcare product information selecting computer and a

5 communications network for transmitting healthcare related information from at least one of the plurality of devices to the selecting computer for storage in the database, wherein the selecting computer selects healthcare product information for display to the user based on the healthcare related information entered from at least one of the plurality of devices.

10 One embodiment of the present invention is a computer system for displaying targeted healthcare advertisements to a computer user comprising an advertising selecting computer, a plurality of devices for enabling entry of healthcare related information into the system, a database for storing the healthcare related information and advertising information connected to the

15 advertising selecting computer and a communications network for transmitting healthcare related information from the devices to the selecting computer for storage in the database, wherein the advertising selecting computer compares the healthcare related information to the advertising information and selects advertising information for display to the user that is related to the

20 healthcare related information entered from at least one of the plurality of devices. The healthcare related information comprises information received from a healthcare group consisting of healthcare providers, patients, healthcare service organizations, pharmaceutical companies, healthcare product and service vendors, pharmacies, medical facilities, healthcare

information services, medical record databases, government agencies, non-profit organizations, health research organizations and billing companies. The system also may contain a database of stored non-healthcare related information connected to the advertising selecting computer wherein the  
5 selecting computer compares the healthcare related information and the non-healthcare information to the advertising information and selects advertising information for display to the user that is related to the non-healthcare information. The plurality of devices may be wireless portable computer devices, set-top boxes, web TV devices, personal digital assistant devices,  
10 personal computers, handheld portable computers, wireless telephone devices and wireless personal access devices and the like.

The advertising selecting computer constructs a medical record for a patient using healthcare information selected from at least one of the healthcare group and transmits the medical record via the communications  
15 network to a computer user. The advertising selecting computer transmits a pharmaceutical advertisement to at least one of the plurality of devices for display via the communications network and in response to a healthcare provider user selecting the displayed pharmaceutical advertisement, a prescription for a patient is automatically created. The advertising selecting  
20 computer collects information concerning a number of patients the healthcare provider has referred to a particular website and calculates revenue to be paid to the healthcare provider user based on the number and types of the prescriptions. The advertising selecting computer calculates a revenue amount to be paid to the healthcare provider for using the computer system.

The communications network is selected from the group consisting of a global communications network, a wide area network, a communications inter-network, a local area network, a wireless telephone network, a satellite network and a cable television network.

5           In one embodiment, the present system comprises a health information manager computer program for accepting information from a plurality of electronic sources accessed through a global communications network and organizing the information from the plurality of sources to create patient medical records and using the information from at least one of the plurality of  
10 sources to select healthcare product advertisements for display to a user based on the patient medical records and healthcare provider records.

A method of displaying targeted healthcare product information to a computer user in the present invention comprises using a medical information database, including patient medical information, and a healthcare product  
15 information database and in response to a request from a client computer, comparing the medical related information to the health care product information database and selecting healthcare product information to be displayed to the user that is related to the medical information. The user may be anyone authorized to access the medical information, particularly a patient  
20 and a healthcare provider. Healthcare product information may include healthcare service information. The healthcare product information may be an advertisement, particularly a pharmaceutical advertisement for an individual drug. Patient medical information and healthcare provider information may be collected from at least one of a plurality of sources and healthcare product



advertisements are selected for display to a computer user based on the patient medical information and healthcare provider information and the advertisements are transmitted to a computer user for display. At least one of the plurality of sources information may be user entered data and user actions  
5 collected as a user navigates through an electronic web page display. The pharmaceutical advertisement for a drug is displayed on a computer screen and the healthcare provider can select the drug displayed on the screen and an electronic prescription for the drug for a patient is initiated or automatically created by the computer system. The pharmaceutical advertisement for a  
10 drug is displayed on a computer screen and the healthcare provider can select the drug displayed on the screen and more information about the pharmaceutical is displayed. In addition, the initiated prescription can be initialized to parameter values based on the patient medical information. The electronic prescription then may be electronically sent to a patient-selected  
15 pharmacy. If the prescription contains at least one refill, at least one prescription refill may not be sent to the patient-selected pharmacy and is electronically stored for the patient. The electronically stored prescription refill may then be sent to the patient-selected pharmacy upon request of the patient.

20 The patient medical information includes drugs the patient is allergic to, has had adverse reactions to, drugs in the same class as drugs the patient has had an adverse reaction to, drugs the patient's family has had adverse reactions to, and drugs for which genetic profiling has indicated that the patient may have adverse reactions to. Pharmaceutical advertisements for

such drugs are filtered prior to display. Using the patient medical information, the system may also predict the drugs the patient may have an adverse reaction to (based on medical history or interactions with other drugs) and filters the pharmaceutical advertisements for those drugs. Drugs that are not  
5 included in the formulary of the patient's insurance company may be filtered from the display. Filtering may comprise not displaying the drug or displaying the drug with a warning.

The display of pharmaceutical advertisements may be prioritized according to an amount of revenue received for displaying each  
10 pharmaceutical advertisement or according to the amount of revenue received for displaying pharmaceutical advertisements for pharmaceuticals from a selected company.

The computer-implemented method of the present invention comprises using healthcare information collected from a plurality of sources, selecting  
15 healthcare product information for display to a healthcare provider based upon information from at least one of the plurality of sources and the process the healthcare provider has selected from a computer display within a healthcare provider's computerized workflow process and displaying the healthcare product information to the healthcare provider on the computer  
20 display during the workflow process. The display may be transmitted to the healthcare provider in real-time. The healthcare product information may be advertisements for medical products or services, which may be pharmaceutical advertisements for specific drugs. The computerized workflow process may comprise such as creating an electronic medical record for a

patient, counseling the patient, reviewing the electronic medical record, updating the electronic medical record, creating an electronic prescription, selecting medical tests to be performed on the patient, reviewing results of medical tests performed on the patient, reviewing medical reference information and electronically annotating medical reference information. The plurality of sources may include information from at least one of the sources such as a patient medical record, patient-entered information, healthcare provider entered patient information, health information, medical facility entered patient information, pharmacy information and insurance company entered patient information. Healthcare product information is selected for display based on information from at least one of these sources along with the process the healthcare provider has selected within healthcare provider's computerized workflow process. The sources may be accessed through a global communications network. The healthcare provider can select healthcare information from these of sources and can electronically annotate the healthcare information for a recipient. The healthcare information and the electronic annotation is merged into a information file and electronically send the merged information to the patient through a global communications network for display to a recipient.

Information displayed to a user can be customized based on the patient medical information, the healthcare provider information and the patient-entered data.

In one embodiment, a computer-implemented method of displaying targeted healthcare product information to a computer user comprises using

stored medical information from a plurality of sources. Those sources may be a patient's medical history for a selected patient, healthcare provider information and prescription writing habits of a healthcare provider. The method associates the medical information from the at least one of the  
5 plurality of sources with stored healthcare advertisement information to select an advertisement for display to a user that is related to the at least one of the sources. The healthcare advertisement is then transmitted for electronically displaying to the user.

Revenue can be provided to the healthcare provider based on the number of  
10 patients of the healthcare provider that visit a specified website. Revenue can also be provided to the healthcare provider for using the computer system.

In the present system and method, when a physician writes a prescription order that includes refills, those "refill options" may be electronically stored in a data base and only a single prescription order is sent  
15 on to the selected pharmacy for fulfillment. When the time comes to refill the prescription, the patient, not the initial filling pharmacy, has control over those refill options. For example, the patient may elect to send the first refill order to a pharmacy near the patient's home, the second refill to a pharmacy near the patient's office, and the third refill to an Internet-based pharmacy. This allows  
20 the patient to shop for the greatest convenience and/or value for the refill prescriptions, rather than being tied to the pharmacy that filled the initial order. The computer-implemented method of implementing the present invention for managing prescription refills comprises entering a prescription into a computer program, if the prescription has at least one refill, storing by the

computer program the at least one refill, transmitting by the computer program the at least one refill to a patient-selected pharmacy, updating the number of remaining refills and storing any remaining refills by the computer program, and repeating the process of transmitting refills until no refills remain. The refill  
5 is transmitted to a patient-selected pharmacy upon a request by the patient. The refill is transmitted to a patient-selected pharmacy prior to the patient using all of a current prescription.

The software programs incorporating these methods may be embodied on a computer-readable medium.

10

#### BRIEF DESCRIPTION OF THE DRAWINGS

Fig. 1 is a functional block diagram of the health information management system.

Figs. 2A through 2C are tables that detail the specific types of participants in the health information management system.

15

Fig. 3 shows the networked health information management system.

Figs. 4A through 4E are tables that detail the types of data exchanged between the system components of the health information management system.

20

Fig. 5A shows the healthcare provider client computer utilizing a local area network to access the external network connection.

Fig. 5B shows client computers utilizing a local area network at the healthcare provider's facility and a proxy server to access the external network connection.

Fig. 5C shows client computers at the healthcare provider's facility connecting directly to the external network.

Fig. 5D shows client computers at the healthcare provider's facility connecting to base stations.

5 Fig. 6 shows an embodiment of the health information manager.

Fig. 7 is a flowchart of one embodiment of the health care provider system access process.

Fig. 8 is a flowchart of one embodiment of the prescription writing process.

10 Fig. 9 is a flowchart of the history and examination process.

Fig. 10 is an exemplary display of a patient record input screen that is suitable for use by a healthcare worker in the history and examination process.

15 Fig. 11 is an exemplary display of a lab results screen suitable for use by a healthcare worker.

Fig. 12 is a flowchart of the process of entering, selecting, annotating and transmitting health-related information.

Fig. 13 is a flowchart of the process of selecting, reviewing, ordering or annotating lab and other tests.

20 Fig. 14 is a flowchart of a patient's interaction with the healthcare information management system for entering patient information.

Fig. 15 is a flowchart of a patient's interaction with the healthcare information management system.

Fig. 16 is a block diagram of the function of determining the healthcare information, product information and advertisements to display.

Fig. 17 is a flowchart of the healthcare information manager process for selecting healthcare advertisements to be displayed after the healthcare worker enters a diagnosis of a patient.

Fig. 18A is a block diagram of the process of automatically writing a prescription for a patient.

Fig. 18B is an illustration of a screen for prescription parameters selection screen for implementing the process of Fig. 18A.

Fig. 19 is block diagram of the process of using patient-entered information and healthcare worker entered information to influence advertisement selection and display.

Fig. 20 is block diagram of the process of using patient-entered information and healthcare worker entered information to create a patient's medical record.

Fig. 21 is a block diagram of the process of merging healthcare provider or patient generated information and other healthcare information and allowing the healthcare provider to edit and annotate the information.

Fig. 22 is a flowchart of an exemplary interaction of a patient and a healthcare worker with the healthcare information and delivery system.

Fig. 23 is a pictorial screen diagram illustrative of a pharmacy selection screen.

Fig. 24 is a pictorial screen diagram illustrative of a selected pharmacy display screen.

Fig. 25 is a pictorial screen diagram illustrative of a pharmacy map screen.

Fig. 26 is a pictorial screen diagram illustrative of a customized screen displayed to a patient when the patient logs onto the health information management system.

Fig. 27 is a pictorial screen diagram illustrative of a customized blood pressure data input screen.

Fig. 28 is a pictorial screen diagram illustrative of a customized blood pressure results graph screen.

Fig. 29 is a pictorial screen diagram illustrative of a customized patient complaint screen.

Fig. 30 is a pictorial screen diagram illustrative of a customized complaint-specific diagnostic screen.

Fig. 31 is a pictorial display diagram illustrative of a customized prescription pad screen.

Fig. 32 is a flowchart of the process of storing refills of a prescription for future use.

#### DESCRIPTION OF THE DRAWINGS

Fig. 1 is a functional block diagram of the health information management system 100. A healthcare information manager 101 coordinates the transmission and receipt of information from other participants in the health information management system 100. The participants may represent individual people, entities, or businesses. These participants include healthcare providers 102, patients or patients' proxy 103, healthcare services



organizations 104, pharmaceutical companies 105, non-healthcare product and service vendors 106, healthcare product and service vendors 107, pharmacies 108, medical facilities 109, healthcare information providers 110, non-healthcare information providers 111, health and medical record  
5 databases 112, and billing companies 113. A patient proxy may be a person or organization authorized to act on behalf of a patient, such as a parent for a minor patient or a guardian for an incapacitated patient.

Figs. 2A through 2C are tables that provide examples of the specific types of participants 102-113 in the health information management system. It  
10 is further noted that other participants not specifically listed in Figs. 2A through 2C may be involved in some aspects of the health information management system, such as intermediary institutions.

Fig. 3 shows the networked health information management system. Each participant is equipped with a computing system 120 –131 to facilitate  
15 networked communications. The patients or patients' proxy 103 and pharmacies 108 are shown using devices 121 and 126 in the form of a personal computer to connect and interact with the health care information management system, although other types of devices for interaction may be used including laptops, notebooks, handheld computers, set-top boxes,  
20 computer servers, hand-held mobile devices such as mobile personal digital assistants with Internet access or mobile phones with Internet access, wireless personal access devices, telephone combination devices and the like. When the patient is at the physician's office and wants to access the health care information management system, the patient may use a kiosk-

based device or other device as listed above. The healthcare provider 102 may use a device such as a portable, wireless personal access device (PAD) that uses radio frequencies to enable to access the Internet or send and receive email within a certain number of feet of the device's base station. One  
5 such device is National Semiconductor's WebPAD™. The healthcare provider may also use any of the other devices as listed above to communicate within the networked health information management system.

The healthcare services organizations 104, pharmaceutical companies 105, non-healthcare product and service vendors 106, healthcare product and  
10 service vendors 107, medical facilities 109, healthcare information providers 110, non-healthcare information providers 111, health and medical record databases 112, and billing companies 113 and healthcare information manager 101 are shown having devices 122-125 and 127-132 for interacting with the health information management system in the form of a computer  
15 server, although other types of computing devices may be used including mainframe computers, minicomputers, a networked set of computers, personal computers, laptops, notebooks, handheld computers, set-top boxes, hand-held mobile devices such as mobile personal digital assistants with Internet access or mobile phones with Internet access, wireless personal  
20 access devices, telephone combination devices and the like. The device may be a single computer, multiple computers connected independently to a network or collections of several computers providing client services.

The devices 120-132 accept input information in many forms including keyboard, mouse, touchscreen, light pen, voice recording, voice-to-text transfers and the like.

The devices 120-132 are connected with each other via a data  
5 communication network 123. The network 123 may be a public or private communication network such as, but not limited to, a global communications network (commonly known as the Internet), a Wide Area Network (WAN), a  
Local Area Network (LAN), interactive television (ITV), cable or a wireless network. For the purposes of discussion, it will be assumed that the network is  
10 embodied as the Internet. In this context, the devices 120-132 may or may not be connected to the Internet at all times. For instance, some devices may employ a modem to occasionally connect to the Internet while other units may maintain a permanent connection. In light of the importance of privacy concerns, the health care information and delivery management system  
15 employs information security such as a physically secure network, data encryption, authorization certificates, digital signatures and other techniques, or combinations of information security techniques which are known in the network security arts.

The system can be implemented as a client-server software  
20 architecture where the computing units comprising the healthcare providers 102, patients or patients' proxy 103, healthcare services organizations 104, pharmaceutical companies 105, non-healthcare product and service vendors 106, healthcare product and service vendors 107, pharmacies 108, medical facilities 109, healthcare information providers 110, non-healthcare

information providers 111, health and medical record databases 112, and billing companies 113 are clients and the healthcare information manager 101 acts as the server. In one embodiment, the clients may be web browsers and the server may be a web server. Other implementations are possible.

5 Figs. 4A through 4E are tables that detail the types of data exchanged between the system components of the health information management system. The healthcare information manager 512 transmits data to and receives data from the other participants in the health information management system. The particular data transmitted and received by the  
10 information healthcare providers 500, patients or patients' proxy 501, healthcare services organizations 502, pharmaceutical companies 503, non-healthcare product and service vendors 504, healthcare product and service vendors 505, pharmacies 506, medical facilities 507, healthcare information providers 508, non-healthcare information providers 509, health and medical  
15 record databases 510, and billing companies 511 are listed in Figs. 4A through 4E. In one embodiment of the system, the healthcare information manager 512 acts as the central controller of all information in the system. Other embodiments, including a distributed system model in which data is transmitted directly between other participants in the system, are possible.

20 Figs. 5A through 5D illustrate possible configurations for the healthcare provider (102 in Figs. 1–3). These configurations can also extend to the other participants in the system.

Fig. 5A shows client computers utilizing a local area network at the healthcare provider's facility to access the external network connection.

Exemplary healthcare providers such as the office staff 140, physician 142 and nurse 143 along with the patient who is visiting the healthcare provider's facility 141 are connected via a local area network 144 to an external network 145. Examples of a the local area network include an Ethernet network, a  
5 token ring network, an infrared network, radio or wireless network. The local area network may connect to the external network connection 145 via a modem, cable modem, ISDN or ADSL connection, router, gateway or switch, or other connection which will then facilitate the connection of the client with the healthcare information manager 146.

10 Fig. 5B shows client computers utilizing a local area network at the healthcare provider's facility and a proxy server to access the external network. It is similar to Fig. 5A with the exception that a proxy server 147 acts as an intermediary between the client and the Internet so that the system can ensure security, administrative control, and caching service. A proxy server  
15 may be part of a gateway server that separates the client network from the outside network and a firewall server that protects the client network from outside intrusion. An advantage of a proxy server is that its cache can serve all users. If one or more Internet sites are frequently requested, these are likely to be in the proxy's cache, which will improve user response time. The  
20 server 147 may include a local database that stores data locally and is accessed for applications that employ the data. Almost any functionality that would normally be done at the main server can be done on the proxy server. The proxy server may facilitate transmission of data among devices at the healthcare center to reduce dependence on the external network so that the

system will still function if a network connection fails. Typical applications that access the database in the server 147 include cross-checking of physician prescriptions with patient medications and allergies, cross checking of physician prescriptions and patient susceptibility to adverse drug interactions, 5 determining the pharmacy benefit management company of the patient and other functionality. The server 147 selectively performs operations such as merging selected physician input data with selected patient-input data and selected staff input data, and transmits both merged and unmerged data to the external network 148 to be processed by the healthcare information 10 manager 146. The server also provides for the generation and transmission of dynamic data such as dynamic web pages. The server can service the client computers during a failure of the network connection and provide better performance by avoiding wide area network (WAN) communication.

Fig. 5C shows client computers at the healthcare provider's facility 15 connecting directly to the external network. The staff 140, patient 141, physician 142 and nurse 143 are connected directly to the external network 145 and then in turn to the healthcare information manager 146.

Fig. 5D shows client computers 140-143 at the healthcare provider's facility connecting to base stations 150-153 that in turn connect to a local area 20 network 144 which connects to an external network 145 that facilitates communication between the clients 140-143 and the healthcare information manager 146 over the external network 145. This configuration is used when the client's computers are wireless devices that must be connected (called docking) to a base stations 150-153 before data from the wireless devices can

be transmitted or received from the health information manager 146. This configuration is also used when the device is a portable, wireless personal access device (PAD) that uses radio frequencies to enable to access the Internet or send and receive email within a certain number of feet of the device's base station and does not need to be physically connected to a base station to transmit or receive data from the network. The base station 150-153 may provide one or more of the following functionality: network connectivity, synchronization of files or records between the terminal's version and the base station's version, and generation and transmission of dynamic data such as dynamically generated web pages.

Fig. 6 shows an embodiment of the health information manager 600. In this embodiment, the health information manager 600 consists of a front-end web server 601 connected to a communications network 604 (which may be a global communications network such as the Internet, a Wide Area Network (WAN), a Local Area Network (LAN), interactive television (ITV), cable or a wireless network), a set of business logic programs 602 (for example, Common Gateway Interface scripts, Active Server Pages, Java Servlets), as well as software specifically to implement the functions of the health information management system, and a database 603. Practitioners versed in the state of the art will recognize that this functionality could be implemented in several ways. One or more of these layers could be omitted, the system could distribute data using a file system, the system could use a file system for back-end data storage rather than a database, and combinations of similar techniques could be used. These logical modules may run together on a

single machine, on separate machines connected by a network, or may be distributed across a collection of machines connected by a network.

In one embodiment, applications used by users of the system are implemented as a series of interconnected web pages, some of which are static and provided by the front end web server 601 and some of which are dynamically generated in response to immediate user input. The static pages include health care provider pages 605, log-in pages 606, patient selection pages 607, prescription writing pages 608, history and examination pages 609, patient data entry pages 610, lab and test order pages 611, advertisement pages 612 and health information pages 613. In this embodiment, the dynamically generated pages are created by business logic programs 602 that access the database 603. Applications of this sort include the health care provider programs 614, log-in programs 615, patient selection programs 616, prescription writing programs 617, history and examination programs 618, patient data entry programs 619, lab and test order programs 620, advertising and information selection programs 621, health information programs 622 and data merge programs 623. Other implementations are possible such as running some of these functions or parts of these functions at the client or client proxy machine. The database 603 contains stored data records used by the business logic programs 602 and the front end server 601. The database records include health care provider records 624, log-in records 625, patient records 626, prescription writing records 627, history and examination records 628, patient data entry records 629, lab and test order



and result records 630, advertisement records 631, health information records 632 and merged data records 633.

In one method of use of selecting advertising, a request arrives at a HTTP Hypertext Transfer Protocol (HTTP) front end server 601 and based on  
5 the object identified by the Uniform Resource Locator (URL) which is the address of a file resource accessible on the Internet. In the request, the front end server 601 sends the request to the advertisement business logic program 602. The advertisement business logic program 621 reads from several of the databases 603 such as the current patient's complaint from the  
10 patient data entry records 626, the patient's smoking status from the patient data entry records or from the patient records, the doctor's specialty from the doctor or clinic relation 624, diagnosis of the patient's illness from the patient records 626 , the patient's current list of medications from prescription writing 627 or patient records 626, medications allowed by an insurance formulary  
15 from health information records 632 and target markets for advertisements from the advertisement records 631. Based on such factors, the advertising selection program 621 chooses an advertisement to display and directs the front end server 601 to transmit that advertisement page to a remote machine through the communications network 604. For example, when a request for  
20 an advertisement arrives through the communications network 604 from a machine being used by a cardiologist that is working with a particular patient, the advertisement program 621 could decide whether to display an advertisement for a smoking cessation product by querying the patient's database records to determine if the patient smokes, then querying the

physician's record 624 of what smoking cessation products the doctor has prescribed to patients or sent information about to patients in the past, and finally querying the advertising database 631 to find smoking cessation advertisements. In another example, when a general practitioner uses the system while examining a patient complaining of allergies, the advertising selection program 621 would query the doctor's past prescribing habits 624 and 627, the patient's insurance coverage 626, current medications and allergies 626 and 627, and the advertising database 631 to select from among allergy medications to advertise based on payments by different advertisers to target specific combinations of doctor and patient characteristics.

In this figure, the subcomponents (records) of the database 603 represent different logical groupings of data relevant to the system. For example, the healthcare provider records 624 could be implemented as a set of relations keyed by clinic ID that lists for each clinic, the clinic's name, list of doctors at the clinic, list of patients of the clinic, clinic address, clinic phone number, clinic fax number, security and network information to access the clinic's printer, patients currently signed in at the clinic, and account information used by clinic staff to update the clinic records. Additional healthcare provider relations keyed by staff identification numbers provide storage and access to records regarding individual staff members such as doctors, nurses, technicians, and administrative staff at a clinic. Such information could include the name of the staff person, title of the staff person, Drug Enforcement Administration ID of the staff person, a log of past actions by the staff person (such as prescriptions written, patients seen, topics of

interest, and the like). The log-in records 625 include records keyed by user IDs with records of user passwords or security keys. The patient records and patient data entry records 626 and 629 are records keyed by patient ID mapping to information including patient complaint, patient long-term  
5 conditions, patient smoking status, patient gender, patient visits, patient interests in topics, and the like. The prescription writing records 627 are records keyed by prescription ID with information such as the medication prescribed, dosage, frequency, prescribing doctor, patient, etc. The history and examination records 628 are keyed by visit ID and include information  
10 such as the doctor, clinic, patient, prescriptions, primary complaint, record of the history of current illness, a list of labs and tests ordered, record of the physical examination, record of the diagnosis, and the like. The lab and test order and result records 629 are indexed by test identification and list for each exam the visit ID, the name of the test, the result of the test, parameters for  
15 the test. The advertisement records 631 comprise advertised products, restrictions and other data necessary to be able to display a targeted advertisement to the user. The health information records 632 contain health information collected from a variety of sources. The merged data records 633 contain information from various sources that have been merged together, for  
20 example patient entered data may be merged with patient record data and with healthcare worker data. It can also include prescription information and pharmacy selection information. Different groupings and components are, of course, possible within the scope of this invention.

Fig. 7 is a flowchart of one embodiment of the health care provider system access process. In this embodiment, a health care worker logs in 160 and the health information manager function selects health and product information and displays that information to the user 161. The health care worker selects a patient with whom to work 162 and the health information manager function selects health and product information for display to the user. The healthcare worker can then access one or more specific health information management applications such as prescription writing 163, history and examination 164, reference information 165, sending information to a patient 169, and ordering/accessing lab tests 166. The health information manager function selects the health care and product information to be displayed to the user based depending upon a number of factors. The health care worker then returns to the patient selection process 162 or if completed, logs out 168.

At each stage in the process, healthcare information and product information (such as advertisements) related to the healthcare worker, the patient being considered, and/or the specific point in the work process may be presented to the healthcare worker. As additional information about the patient is gathered by the system, the system (in the health information manager function) may use this additional information to select and display new healthcare information and products.

The log-in process 160 gathers identification and authentication information about the health care worker such as the worker's name, the clinic at which the worker is located, the worker's password, information from the

worker's smart card, biometrics identification or authentication information, etc. The result of this step is that the worker is identified to the system. The system may display healthcare and product information, including advertisements, based on factors such as the healthcare worker's or health  
5 facility's specialty 161. For example, the system may display different information to a worker in a geriatric clinic than to a worker in a pediatric clinic.

The patient selection process 162 allows the health care worker to select a patient that will be the subject of the work process. The patient selection process 162 may be implemented in one or more of several  
10 embodiments including automatic transmission of the name and record of the next patient a doctor will see to the doctor's terminal, providing a list of the doctor's patients from which to select, providing a list of patients in the clinic from which to select, providing a list of the doctor's patients in the clinic from which to select, text entry, voice entry, or other means. The system may  
15 display healthcare and product information, including advertising, to the user based on factors such as the patient's complaint, patient's history, and/or the healthcare worker's specialty. For example, if the patient smokes the system might display an advertisement for a nicotine patch. In another example, if the patient has high blood pressure, the system displays advertisements for  
20 hypertension medication. Practitioners versed in the state of the art will recognize that this figure illustrates just one of several possible embodiments of the health care worker data access and information display process; for example, other applications may be added or patient selection may be omitted in some cases.

Fig. 8 is a flowchart of one embodiment of the prescription writing process. The prescription writing process allows a healthcare provider to assemble or select a prescription for the patient. In this embodiment, the healthcare worker may select a drug to be prescribed by one of several  
5 means including by entering the drug's name directly (e.g., by text or voice input), by navigating a series of menus or screens, or by selecting a currently-displayed advertisement at any point in the process. During this process the system may display healthcare and product information including one or more advertisements based on information the system has obtained about the  
10 patient, the doctor, or both. For example, the system might display an advertisement for an allergy medication when the doctor begins prescribing a medication for a patient complaining of allergies.

The healthcare worker enters the prescription entry process 180. If the healthcare worker chooses to enter the drug name directly 181, the system  
15 proceeds to display the prescribing parameters for selection 193.

In another embodiment, for any of the selection strategies 183 through 190, the system may go directly to displaying a list of drugs 192, skipping the alphabetical selection 191.

If the drug name is not entered directly 181, the selection through  
20 navigation of menus or screens is chosen 182 and the healthcare worker then chooses the preferred method for selecting the prescription. The options include selecting the prescription by using the generic name 183 or trade name 184 of the drug, the patient's complaint 185, the formulary selected 186, the diagnosis for the patient's condition 187, the most commonly prescribed

drugs (in general, or based on physician's prescribing history) 188, over-the-counter drugs 189, or the patient's symptom 190. If one of these options is selected 183-190, the system may then display a list of letters of the alphabet and the healthcare worker may choose one of these letters 191. The system  
5 then displays a list of drugs from the selected category beginning with the selected letter and the healthcare worker may select one or more drugs from this list 191. The healthcare worker may also directly select from a list of drugs. Alternatively, if the formulary or most commonly prescribed drugs are selected, the system may directly display a list of drugs appropriate for the  
10 complaint or a list of drugs appropriate for the diagnosis 192. If one of these names is selected, the system proceeds to the prescribing parameters selection 193. At each of these steps, the system may display one or more advertisements 195 selected on the basis of information the system has obtained about the patient, doctor, or both in addition to information regarding  
15 the current location or step in the drug selection process. For example, the system might display an advertisement suggesting a particular blood pressure medication when a doctor is seeing a patient that is complaining of headaches enters a blood pressure that is high.

At any point in the process, the healthcare worker may select a  
20 currently displayed advertisement 195 causing the system to proceed to the select prescribing parameters step 193.

In the prescribing parameters selection step 193, the system allows the healthcare worker to select parameters for the administration of a medication such as the dosage, frequency, form, and duration. The system may also

complete one or more of those prescribing parameters (dosage, form) based on information obtained about the patient such as weight, gender, current medications, and the like. In one embodiment, the system displays a form with selectable options for each parameter and initializes the selection to values

5 likely to be appropriate for the patient based on information about the drug, information about the patient's condition (e.g., acute pain v. chronic pain), information about the patient (e.g., weight, age, gender, etc.). After selecting appropriate parameters, the healthcare provider may select options to store or transmit the prescription. During this stage, the system may display an

10 advertisement based on information about the patient, information about the doctor, and information about the drug being prescribed. For example, the system might display an advertisement for an alternative drug that may be appropriate for the patient than the drug being considered or prescribed. The prescription is then stored to be printed out by the system or electronically

15 transmitted to a pharmacy 194.

Fig. 9 is a flowchart of the history and examination process. The history and examination process 200 allows a healthcare worker to review information about the patient entered by the healthcare worker, patient, or other entity at some previous time and for the healthcare worker to edit this

20 information or add new information to the patient's medical record. Fig. 10 is an exemplary display of a patient record input screen that is suitable for use by a healthcare worker in the history and examination process. The healthcare worker selects the particular category 201 which may include one or more of the following:



a history of present illness information such as a patient's description of his/her chief complaint, source of referral, location of condition, quality of condition, quantity of condition, timing of condition, settings of occurrence of condition, aggravating factors, associated symptoms, and the like 204;

5 past, family, and social history information such as general health, childhood illnesses, adult illnesses, psychological conditions, current illnesses, past injuries, past surgeries, past procedures, post hospitalizations, family medical history, smoking habits, drinking habits, drug habits, exercise habits, eating habits, current medications, allergies, work environment  
10 hazards, genetic information, general constitution, and the like 205;

a review of systems information such as information about the neurological system, ear, nose, and throat, head, respiratory system, cardiovascular system, genitourinary system, gastrointestinal system, endocrine system, integumentary system, musculo-skeletal system, and the  
15 like 206;

a list of the current medications prescribed for the patient along with the patient's allergies to medication, if any 207;

physical examination information related to the above systems 208;  
and

20 laboratory and test results 209. Fig. 11 is an exemplary display of a lab results screen suitable for use by a healthcare worker.

Turning back to Fig. 9, in one embodiment, this information 204-209 is presented to the healthcare worker in a series of forms displayed using a graphical user interface where common choices are presented to the

healthcare worker from which the healthcare worker may select particular items and where additional information may be added in free text or voice format. At all steps in the process, health and product information 202 and advertisements 203 may be displayed on the graphical user interface. The system may update health and product information 202 and advertisements 203 displayed as more information is entered about the patient. For example, if the patient initially complains of a sore throat and the healthcare worker actually finds throat cancer, the system might first show advertisements for over-the-counter throat lozenges and later show advertisements for a new anti-cancer drug based on the new information the healthcare worker entered about the patient. The health and product information and advertisements 202 can be displayed at any time during the workflow process based on any piece or pieces of information gathered about the current patient and/or encounter. After completing the history and physical examination process, the program may return to other processes such as prescription writing, reference, transmitting information to a patient, lab ordering or the like 210 or the process ends 211.

Fig. 12 is a flowchart of the process of entering, selecting, annotating and transmitting health related information from a sender (in this case a healthcare worker) to a recipient 220. The recipient may be a patient or another physician or the like. Using a GUI displayed on a computer screen, the user, a healthcare worker, selects the category or information to be transmitted 221. Information may include books 222, journal references 223, health articles 224, information on video 225, audio information 226 or a 3D

simulation 227. The healthcare worker may annotate the information 228 and the information is transmitted to the recipient 230. At all steps in the process, health and product information 233 and advertisements 232 may be displayed on the graphical user interface. The system may update health and product  
5 information 233 and advertisements 232 displayed as more information is entered about the patient. After the information entry process, the program may return to other processes such as prescription writing, transmitting information to a patient, lab ordering or the like 229 or the process ends 231.

Fig. 13 is a flowchart of the process of selecting, reviewing, ordering or  
10 annotating and transmitting lab and other tests 240. Using a GUI displayed on a computer screen, the user, a healthcare worker, selects the category or test for a patient 241. The healthcare worker can select by the name of the test 242, the category of the test 243, the patient's complaint 244, the patient's diagnosis 245, the patient's symptom 246. The healthcare worker can make  
15 the selection using the keyboard or the point and click device of computer unit, or by using voice or other. The healthcare worker can then order the test 247, annotate the test results 248 or review the test results 249. At all steps in the process, health and product information 253 and advertisements 252 may be displayed on the graphical user interface. The system may update health  
20 and product information 253 and advertisements 252 displayed as more information is entered about the patient. The ordered test 247 may be transmitted to the laboratory for completion 251, the annotated test 248 and the test results 249 may be transmitted to the patient or to another healthcare entity 251 or organization. The program may return to other processes such

as prescription writing, reference, transmitting information to a patient, lab ordering or the like 250 or the process ends 254.

Fig. 14 is a flowchart of the patient's interaction with healthcare information management system for entering patient information. The patient  
5 may enter the information using a display interface of a personal computer, a laptop notebook, an Internet-enable appliance or other type of electronic device. The patient may also enter the information using a computer contained in a kiosk in the physician's office. Alternatively, the patient may provide this information to a healthcare worker in the physician's office and  
10 the healthcare worker may then enter the information in the same way as the patient in steps 261 through 270. The patient logs onto the system with a unique identifier 260. If the patient is not already in the system (a new patient), a blank record and heuristic form is displayed 262 and the patient completes the record and heuristic 263. If the patient is already in the system,  
15 the patient's record for selected portions are displayed 264 (or selected portions of the patient's record). If an update is needed 265, the patient is prompted to update the record 266. The patient completes heuristics for the current illness complaint or reason for the office visit 267. The patient completes pharmacy selection heuristics to select a preferred pharmacy 268.  
20 The patient may also select items of medical or other interest and concern 269. The patient enters his or her email address, if one exists 270. At all steps in the process, health and product information 273 and advertisements 272 may be displayed on the graphical user interface displayed to the user. The system may update health and product information 273 and advertisements

272 displayed as more information is entered about the patient. Optionally, the system may print out the information entered so it may be reviewed by the patient for accuracy 274. After the patient has completed entering information, the process ends 275.

5            Fig. 15 is a flowchart of a patient's interaction with healthcare information management and delivery system whereby the patient accesses the system using a global communications network. The patient logs onto the healthcare information management and delivery system by selecting the healthcare information management and delivery system network home page  
10 280. To access the home page, the patient can use any type of network access device capable of accessing the network such as a computer, video receiver, audio receiver, web pad, or the like. The patient logs onto the network home page, registers onto the system via password, biometrics, smartcard, or the like 281. The registration/login process gathers identification  
15 and authentication information about the patient and authenticates the user prior to granting access and/or displaying the patient's medical information. Once logged on and registered, the patient may access one or more specific applications or information displays. Upon logging on and registering, a home page customized for the patient may be displayed 282. In another  
20 embodiment, the patient logs directly onto the customized home page and accesses one or more specific applications and information displays or the like. The customized home page may include reference information 283 about a disease of the patient, healthcare provider information 284, the patient's medical record 285, product information in general and products for

a certain condition of the patient 286 or appointments with the patient's physician 287. Remote monitoring of patient physiological data by the healthcare provider may be possible using the customized home page 288. For example, if the patient has diabetes, the patient may enter in glucose information daily to be monitored by the healthcare provider. In another example, if the patient has high blood pressure, the patient may enter in their blood pressure daily to be monitored by the healthcare provider. The information entered by the patient is transmitted to the healthcare provider through the global communications network 289 and the patient logs out 290.

At all steps in the process, health and product information 292 and advertisements 291 may be displayed on the graphical user interface displayed to the user. The system may update health and product information 292 and advertisements 291 displayed as more information is entered about the patient. As additional information about the patient is gathered by the system, the system may use this additional information to select and display new advertisements.

Fig. 16 is a block diagram of the function of determining the healthcare information, product information and advertisements to display. The logic for controlling the function of determining and displaying the information and advertisements is located in the healthcare information manager (101 in Fig. 1). The healthcare information manager, at all steps in the data entry and information review processes, determines the health and product information and advertisements 300 that may be displayed on the graphical user interface to the user. The user may be anyone authorized to log onto and view the

healthcare information management and delivery system, but will usually be a healthcare worker or a patient. The system may update health and product information and advertisements 300 displayed as more information is entered about the patient. As additional information about the patient is gathered by  
5 the system, the system may use this additional information to select and display new advertisements. The steps in the process where the healthcare information manager makes the decision to determine if new advertisements and/or product information is to be displayed include, but are not limited to: selecting a patient 301, collecting new information entered by a patient 302,  
10 reviewing medical records 303, conducting a patient history and physical examination 304, ordering lab work 305, receiving lab results 306, checking reference material 307, reviewing old charts 308, diagnosing the patient's condition 309, writing a prescription 310 and setting up physician referrals and return appointments 311, a healthcare worker or patient logging on to the  
15 system, insurance formularies and enrollment status 313, drug interaction check results 314 and information about physician prescribing habits 315.

The healthcare information manager can use every healthcare worker action, choice, and location within the work cycle, to determine the health and product information and advertisements 300 to be displayed. Likewise, the  
20 health information manager can use patient information and patient actions and entry to determine the health and product information and advertisements 300 to be displayed.

For example, once a physician logs onto the system, the logic for controlling the function of determining and displaying the information and

advertisements in the healthcare information manager can display information and advertisements relevant to his or her medical specialty. When the physician selects his or her next patient, the logic can display information and advertisements relevant to the patient's chronic conditions (such as diabetes, hypertension, and the like). When the physician enters a diagnosis, the logic can display information and advertisements for products indicated for the selected diagnosis. In another example, when the physician searches the drug database for a particular drug, information and advertisements relevant to the physician's search based on factors such as the patient's complaint and the letter under which the physician is searching for a drug in an alphabetical list can be displayed. Other types of information used to determine healthcare information and advertisements displayed include the patient's past record, insurance formularies and patient enrollment status, drug interaction check results, physician's prescribing habits and the patient's gender, weight, age, allergies, current medications, and the like.

Fig. 17 is a flowchart of the healthcare information manager process for selecting healthcare advertisements to be displayed after the healthcare worker enters a diagnosis of a patient. The healthcare worker, in this case a physician, enters a patient diagnosis 320. If there are no stored advertisements available for this diagnosis 321, the system displays a generic advertisement 322. If there are stored advertisements available for this diagnosis 321 which include prescription drugs used for treating the medical condition, the advertisements for those prescription drugs are screened against a list of patient's allergies 323. If the patient is allergic to one or more



of the prescription drugs indicating a conflict 324, the advertisements for the conflicting drugs are filtered 325. Filtering an advertisement may disqualify the advertisements so that it will not be displayed, reduce the probability that the advertisement will be displayed, select a related advertisement for display, 5 attach a warning message that will be displayed along with the advertisement or take some other appropriate action. In either case 324, the advertisements are screened against the patient's current medications 326. If there is a conflict between the patient's current medications and the advertisements for the prescription drugs used to treat the patient's condition 10 327, the advertisements for the conflicting drugs are filtered 328. In either case, the advertisements are screened against the physician's prescribing habits for the patient's diagnosis 330. If the physician usually prescribes a certain brand 331 (called Brand X) and Brand X is included as one of the stored advertisements 332, the system can display the advertisement for 15 Brand X 333. If Brand X is not included as one of the selected advertisements 332 or if a competitor has purchased an advertisement, the system displays an advertisement Brand Y 334. If the physician does not usually prescribe Brand X 331, the system displays the stored advertisement(s) that most closely fits with the patient's diagnosis, allergies, current medication and 20 physician's prescribing habits for this diagnosis 335 or a competitor's advertisement. The physician then prescribes the medication 336. The physician may choose to select one of the advertised medications or not 336. If there are additional stored advertisements for relevant symptom treating

medications 337, the process is repeated at step 323. Otherwise, the physician transmits the prescriptions 338 to a pharmacy for filling.

Fig. 18A is a block diagram of the process of automatically writing a prescription for a patient. An advertisement for a medication (usually a  
5 prescription drug) that is appropriate for the patient's disease, or complaint, or condition is displayed as discussed above in Fig. 17. This can occur at any point in the healthcare worker's workflow. The healthcare worker, usually a physician, can select the advertisement at any time during the physician-patient encounter (including during telephone calls, or when the patient is not  
10 in the physician's presence. Selection can be accomplished in any number of ways, including but not limited to a point and click device or a light pen. Patient data and other information 351 available from the patient medical record (which may have been entered into the medical record by the patient, the physician, other medical staff, or other non-medical staff) such as the  
15 patient's age, weight, sex, race, creatinine level, disease states (such as kidney or liver disease or the like), physiological states such as diabetes, hypertension or the like, current medications, past medications, allergies, and other patient medical information 351 is merged and integrated with the advertised prescription selected by the physician to generate the prescription  
20 and treatment regimen 352. The system then is able to select an appropriate treatment regimen including strength, quantity, method of delivery, frequency, and duration of treatment in light of the patient's physiologic/medical state 352. For example, if a physician selects amoxicillin for a healthy adult the system may suggest a standard adult regimen that might include 500mg

tablets three times a day for 7 days. On the other hand, a patient with an elevated creatinine level might receive a modified regimen that could include 250mg tablets three times a day for 7 days. An appropriate treatment regimen for a child would be based on the child's weight, and could include 1  
5 teaspoon of 125 mg/ml amoxicillin three times a day. The patient-selected pharmacy information 353 is used to transmit the prescription to the appropriate pharmacy 354. The pharmacy may be a traditional "brick and mortar" pharmacy or may be an Internet based pharmacy. The transmission can be via the global communications network or if the prescription is to be  
10 transmitted to a traditional brick and mortar pharmacy, transmission can occur via phone or fax. The prescription can also be printed. The physician can also select the advertisement to request more information about the pharmaceutical prior to making a prescribing decision.

Fig. 18B is an illustration of a screen for prescription parameters  
15 selection screen for implementing the process of Fig. 18. In one embodiment, an electronic "prescription pad" display is designed in such manner so that the physician would not need to use drop-down menus, keyboard entry or handwritten information. All prescribing information for a specific patient on a specific medication can be included in the open display. The suggested drug  
20 regimen could be demarcated from other prescribing options by a variety of methods including highlighting text, underlining, spacing or other methods. The physician could change the suggested regimen by selecting alternative options. For example a physician may wish to increase the frequency of medication to 4 tablets per day instead of three tablets per day.

Fig. 19 is block diagram of the process of using patient-entered information and healthcare worker entered information to influence advertisement selection and display. Patient-entered information 360 can consist of any information entered by the patient, medical or non-medical. Examples include: street address, e-mail address, zip code, medical complaints, medical conditions, current medications, allergies, history of present illnesses, past medical history, family medical, and social history, and review of systems. Healthcare worker-entered information 361 can consist of any information entered by the healthcare worker about the healthcare worker or the patient and can include medical and non-medical information. The information is merged together and the appropriate advertisement is displayed for the particular situation and user 362.

Fig. 20 is block diagram of the process of using patient-entered information and healthcare worker-entered information to create a patient's medical record. Patient-entered information 365 can consist of any information entered by the patient, medical or non-medical. Examples include: street address, e-mail address, zip code, medical complaints, medical conditions, current medications, allergies, history of present illnesses, past medical history, family medical, and social history, and review of systems. Healthcare worker-entered information 366 can consist of any information entered by the healthcare worker related to the patient's medical record and can include medical and non-medical information. Examples of medical information about the patient include but are not limited to history of present illness, review of systems, allergies and current medications, physical

examination findings, tests performed, lab results, interpretations, review of test and lab results, and prescribing preferences. The information is merged together and a unified medical record is created for storing in a medical record database or off-line, printing, or transmitting 367.

5            Fig. 21 is a block diagram of the process of merging healthcare provider or patient generated information and other healthcare information and allowing the healthcare provider to edit and annotate the information. Healthcare provider and/or patient generated system information 370 from the healthcare information manager and healthcare information including  
10 information from web databases, computer stored articles, video, books, audio, journals, illustrations and advertisements, computer simulations and any type of information from an Internet website 371 are merged together 372. The healthcare provider is able to annotate and where appropriate edit the healthcare information and the healthcare provider and patient generated  
15 system information. The edits and annotations can be visual (such as text or pointers on the graphical user interface), video or audio. The information, edits and annotations can be margin notes, highlighting, a commentary, a notes, a list of recommended articles, video with audio and/or written annotation, audio, computer simulations, and review notes. The merged  
20 information may then be transmitted to the patient, to another healthcare provider or to a medical facility. As an example, a healthcare provider who is a cardiologist could modify the film of a cardiogram adding voice information and visual cues such as pointers to explain to a patient the extent of the patient's coronary artery disease. The information could then be transmitted to

the patient. As another example, a computer simulation of the heart could be modified by adding voice information and visual cues such as pointers to explain to a patient the extent of the patient's coronary artery disease. As another example, the annotation could be as simple as underlining an important part of a journal article that the healthcare worker wants the recipient to read.

Figs. 22A through 22H are flowcharts of an exemplary interaction of a patient and a healthcare worker with the healthcare information and delivery system. A patient enters a physician office and is directed to a computer input device 380. The patient identifies himself to the system 381. Identification can take the form of the patient entering name and a unique identifier (such as a social security number) using the computer input keyboard or mouse, inserting a smartcard containing the patient's identifying information into a smartcard card reader device connected to the computer, or using finger print or other type of biometrics identification. If fingerprints or other type of biometrics identification is used, a biometrics device which is a reader or scanning device along with software that converts the scanned information into digital form is used along with a database that stores the biometrics data for comparison with entered biometrics data. Any type of identification scheme that identifies the patient to the health information manager computer program can be used. Once the patient is identified, if the patient is not currently registered on the health information management and delivery system 382, the patient is prompted to enter medical information that will be used to create the patient's medical record 383. If the patient is registered 382, the health

information manager retrieves the patient's past medical records. For the purposes of this example, the patient is a forty-five year old male. The patient's record indicates that the patient smokes three packs of cigarettes per day, the patient has not used any smoking cessation products and that the

5 patient has conducted searches from the physician's website for articles about quitting smoking 384. Using the information from the patient's medical record, the health information manager causes a display advertisement for smoking cessation products to be displayed to the patient computer screen 385. The patient enters relevant medical information about his current condition. From a

10 menu of options, the patient selects "Sore Throat" as his chief complaint 386. The patient also indicates that he has associated symptoms including a fever and a persistent cough 386. Examples of relevant medical information includes chief complaint, source of referral, description of problem/complaint, location, quality, quantity, timing, settings, aggravating factors and associated

15 symptoms. Using the information entered by the patient, such as the associated symptoms of cough and fever, the health information manager displays an advertisement about a sale on cough products at a local drugstore or at an Internet website store 387.

The patient enters/updates information relating to past medical, family

20 medical and social histories 388. In this example, the patient indicates that he now smokes two packs of cigarettes per day, is allergic to penicillin-based drugs and is currently taking a prescription medication for allergies and acetaminophen for his fever. Examples of such information include but are not limited to general health, childhood illnesses, adult illness, psychological

conditions, injuries, operations, hospitalizations, family medical conditions, smoking/drinking/drug habits, allergies, current medications and work environment hazards.

The health information manager uses this information, in this case  
5 particularly the allergy and current medications to screen advertisements to display to the healthcare worker or to the patient 389. The health information manager updates the patient's medical record with this new information. The patient proceeds to the "Review of Systems" screen 390. The healthcare information manager may prompt the patient to go to this screen or may  
10 automatically display the Review of Systems screen to the patient based upon where the patient is in the process. A review of systems includes but is not limited to the patient's general constitution, neurological system, ear, nose and throat, respiratory system, cardiovascular system, genito-urinary system, gastrointestinal system, endocrine system, integumentary (skin) system,  
15 musculo-skeletal system. The patient answers questions and enters information about his current state of health. In this example, the patient selects "fever" under the category General Constitution. Under the category Ear, Nose and Throat he selects "sore throat" "persistent cough", "nasal stuffiness", and "painful to swallow".

20 The healthcare information manager then prompts the patient to enter criteria for selecting the pharmacy to which prescriptions will be sent 391. Examples of such criteria include but are not limited to: pharmacy location (by city, street, zip code, etc.), hours of operation, insurance acceptance, delivery options available and type of store (grocery, pharmacy, Internet web site).



Using the information entered by the patient, the healthcare information manager generates a list of pharmacies that meet these criteria. Some pharmacies may be preferentially displayed due to having paid for this premium exposure 392. The patient selects a pharmacy to receive  
5 prescriptions 393.

The healthcare information manager next offers the patient a list of items about which the patient may wish to receive more information 394. The patient selects those items which are of interest 395. Examples of such items include but are not limited to: quitting smoking, heart disease, healthy living,  
10 congestive heart failure, stroke, high blood pressure, arthritis, genetics and disease, and lowering cholesterol. In this example, the patient selects “quitting smoking”, “heart disease”, and “healthy dieting”. The healthcare information manager will use this information later by prompting the physician (or healthcare worker) to ask about the patient’s interests, as well as by  
15 displaying relevant advertisements to the physician about the patient’s interests and concerns.

The healthcare information manager maps the information entered by the patient onto the appropriate medical template for physician review and use during the physician-patient medical encounter 396.

20 Using a computer screen with a graphical user interface, the physician selects the current patient 397. Based on the information gathered from the patient, any past medical history stored for the patient, and physician information that has been previously entered into the system, the healthcare information manager then displays advertisements pertinent to the patient and

the physician. In this example, the healthcare information manager displays a smoking cessation product advertisement, which may result in the physician asking the patient about his smoking habits and possibly result in the physician prescribing a smoking cessation product.

5           Next, the physician reviews the information entered by the patient 399. While interviewing the patient, the physician learns that the patient has been having pain in his chest when he inhales deeply 399. Upon learning about the patient's pain related to breathing, the healthcare information manager analyzes all data and displays an advertisement appropriate for this symptom  
10   on the physician's computer screen 400.

The physician completes his physical exam of the patient and renders a diagnosis of acute strep pharyngitis 401. Using the diagnosis, the health information manager searches stored advertisements for all advertisements for products that might be useful for treating the patient's various associated  
15   symptoms and other conditions (in this example, smoking) 402. In this example, the healthcare information manager searches through all of its antimicrobial drug advertisements. Using the information that the patient is penicillin allergic, the health information manager rules out any advertisements for drugs containing penicillin or penicillin-based components  
20   403.

The health information manager selects drug advertisements for selected sulfa drugs, quinolones, macrolids and cephalosporins 404. The health information manager screens these advertisements for any possible adverse interactions 405. It is found that cephalosporins have a relative

contraindication for use in penicillin allergic persons. The health information manager attaches an alert to the advertisement containing this information 405.

The physician displays his personalized list of most often prescribed 5 drugs 406. One drug previously prescribed for this patient is Brand X. The physician selects Brand X and the drug name form is automatically inserted onto an onscreen prescription form. The health information manager 407 deselects the Brand X advertisement for two reasons: this visit to the physician is the second in the past month and Brand X was prescribed during 10 the last visit, suggesting that Brand X may not have been effective against the patient's infection 407. The health information manager alerts the physician to the fact that Brand X was previously prescribed and had no apparent curative effect 408.

The health information manager evaluates the two most applicable 15 advertisements based on the patient and physician entered information 409, including the patient's insurance coverage and the insurer's formulary list of covered medications. In this example, the health information manager selects a different drug, Brand Y, which is covered by the patient's insurance company 409. An advertisement for Brand Y is displayed to the physician 20 410.

If the physician selects the drug advertisement, the selected drug is inserted onto the on-screen prescription form 411. At the same time, the health information manager selects advertisements from any information contained within the system including the patient's medical record, lab test

databases and patient-entered data 412. Noting the patient's associated symptom of cough, the health information manager displays an advertisement for a cough medicine 413. It may also display an advertisement for a prescription strength analgesic for treating the patient's chest pain 414. Since  
5 all advertisements are patient specific for either the chief complaint, diagnosis, associated symptoms or other patient conditions, the physician may prescribe any of these medications by selecting the advertisement.

In this example, the physician selects each of these advertisements and a prescription is generated for each 415. In this example, the patient then  
10 asks the physician for a refill for allergy medication 416. The health information manager checks the medical record and finds the name of the current allergy medication, Brand V 417. In this example, two advertisements for allergy medications have been previously stored in the system one for the patient's medication and that of a competitor allergy medication 417. The  
15 competitor allergy medication Brand R is displayed as an advertisement because the competitor's company has paid for that service whenever Brand V is requested for a refill. After checking for possible allergies and adverse reactions for both drugs, the health information manager displays an advertisement for the competitor's allergy medication Brand R 418. The  
20 physician selects the advertisement and the medication is prescribed 419. All prescription data entered by the physician is then merged with the pharmacy selection and routing information entered by the patient and the prescriptions are electronically sent to the patient's selected pharmacy for filling. If the prescription includes drug refills, the healthcare information management

system has the capability to send less than the total number of refills of the prescription to the pharmacy and to store the refills. The patient can then have the prescription refilled at a pharmacy that is different from the pharmacy that filled the original prescription.

5           Practitioners versed in the state of the art will recognize that other variations are possible. For example, the organization of menus or organization of the selection process might easily be changed without changing the fundamental nature of the process.

Fig. 23 is a pictorial screen diagram illustrative of a pharmacy selection  
10   screen. This screen 525 may be used by a patient to enter selection criteria 526. The health information manager performs an analysis of the selection criteria 526 to determine specific pharmacies that meet or most nearly meet the patient's criteria. Fig. 24 is a pictorial screen diagram illustrative of a selected pharmacy display screen 527. The specific pharmacies 528 are  
15   listed on a pharmacy display screen shown. Fig. 25 is a pictorial screen diagram illustrative of a pharmacy map screen 529. The specific pharmacy selected by the patient in Fig. 24 is shown on the map 530.

Fig. 26 is a pictorial screen diagram illustrative of a screen displayed to a patient when the patient logs onto the health information management  
20   system, using their patient identification number 531. In this example, a patient actuates a hyper-link to the patient's cardiologist. This screen is customized not only to the patient but also the patient's cardiologist, and the general field of cardiology. Links throughout the patient-cardiologist customized screen 531 create connections to various cardiology topics

including current cardiology news, medical and other opinions, books and periodicals, treatment updates, and conference summaries. Other links allow the patient to receive advertising relating to various products including medical products and services 532. The patient-cardiologist customized  
5 screen 531 also includes links to a screen that allows the patient to make an appointment with the patient's cardiologist, and links for execution of on-line medical testing such as blood pressure testing.

In the example, the patient actuates the "update blood pressure" link to display a blood pressure entry screen 533 shown in Fig. 27. Fig. 27 is a  
10 pictorial screen diagram illustrative of a customized blood pressure data input screen.

In some embodiments, the patient takes a blood pressure measurement using conventional products (cuffs) and procedures and enters the measurement result via keyboard onto the blood pressure entry screen  
15 533. In other systems, the patient's computer may have a signal acquisition interface electronically measures the patient's blood pressure. Other types of medical and physiological testing may be performed using other medical products and devices. The patient enters the blood pressure reading 534 and selects "Graph This Entry" 535. The blood pressure reading 534 and selection  
20 535 are transmitted to the health information manager which logs the data and transmits the graph results back to the patient as shown in Fig. 28.

Fig. 28 is a pictorial screen diagram illustrative of a customized blood pressure results graph screen. After the patient enters or acquires a blood pressure measurement, the health information manager may generate a time

graph of blood pressure measurements 537 as shown in a blood pressure graph screen 536.

Fig. 29 is a pictorial screen diagram illustrative of a customized patient complaint screen 538 requesting the patient to indicate current physical  
5 symptoms. This screen may be displayed to the patient while he or she is accessing the health information management system from outside of the healthcare facility or when the patient is at the healthcare facility, such as the physician's office. For example, the patient may actuate an appointment link to request an appointment with the physician and a primary-level patient-  
10 complaint template 538 is displayed. Or the patient may enter the data while waiting to see a physician at a healthcare facility or physician's office. In the example, the primary-level patient-complaint template 538 requests the patient to enter one of a plurality of diagnostic conditions. When applicable conditions are flagged, the patient actuates a condition button to advance to a  
15 complaint-specific diagnostic template 539 shown in Fig. 30. The complaint-specific diagnostic template 539 is configured by analyzing information entered when the patient fills in data the primary-level patient-complaint template in Fig. 29. Once the physician has entered information and/or confirmed the information entered by the patient, the merged patient and  
20 physician information combines to form a current medical record 835 which would be similar to the patient record shown in Fig. 10. Typically, the merged current medical record is transmitted to a database in the healthcare information manager for storage and/or to the physician's printer or to a display on the physician's computer or personal access device (PDA).

While the patient is logged onto the system, preferably from a home computer system, the patient can conduct various transactions including: (1) receiving electronic mail such as e-mail containing information requested by the patient from the patient information and prescription handling system database, (2) confirming prescription data, (3) actuating information access icons on the display screen to request and read medical information and prescription data, and (4) actuating icons to access sales and marketing information. Sales information extends beyond pharmaceuticals and medical products to general products. The sales information is targeted to the particular patient on the basis of the patient's physical condition, diagnostic data, and other information within the patient's files in the patient information and prescription handling system database.

Fig. 31 is a pictorial display diagram illustrative of a customized prescription pad screen 540. The display may be viewed on a PDA type device or on any suitable device such as a personal computer, a workstation, a kiosk, or any other type of display device capable of communicating with the health information management system. An advertisement may be displayed 541 during the physician transaction. Once a patient is selected by the physician, advertisements are custom-selected according to a specific patient's conditions, needs, current symptoms, medical and healthcare history, interests, and other specialized information. Software in the health information manager is designed to use patient information including current symptoms, health history information, and other patient and physician entries to specifically target the physician's patient to generate the most effective



advertising to the physician at the most effective time. For example, if a patient is diagnosed with diabetes, intelligent programs in the healthcare information manager may generate advertisements for diabetes medications.

In some systems, advertisements are supplied on the physician PDA  
5 device screen using a touchscreen display that is specifically configured for the particular patient. When the physician touches an advertising icon, software is selectively activated in the healthcare information manager that automatically fills or refills a prescription. Thus the physician efficiently  
10 "writes" a prescription by simply selecting a particular medication on a screen from a list of the patient's current medications or a list of medications that are commonly-prescribed for the patient's condition, or by simply pressing an advertisement icon displayed on the screen. The prescription pad screen 540 includes entry fields for entering a patient name, prescription, and refill options. Rather than typing in a patient name, the physician may actuate a  
15 patient name key to change the display to a patient list display of the prescription pad. The patient list display allows the physician to view a list of the physician's patients. After the physician has selected the patient, the physician may enter a prescription by any of the aforementioned means. The prescription list allows the physician to view a list of the patient's current  
20 medications or a list of common medications for the patient's condition. The prescription list display shows all current prescriptions for the particular patient and alternative prescriptions that may be substituted by the physician to reduce costs or improve selection for the patient.

When the physician selects a medication and selects a refill option by actuating a key on the display. The physician completes the prescription pad screen 540, typically near the end of the patient's office visit, to place an order for one or more medications or other products, specify the number of refills for the medications, and display newly-specified prescriptions for the patient.

Fig. 32 is a flowchart of the process of storing refills of a prescription for future use. Typically, when a physician writes a prescription for a patient which includes refills, the pharmacy that fills the initial prescription gains "rights" to fill the remaining refills, thus "cornering the market" on the refill options for that particular prescription order. In the present system and method, when a physician writes a prescription order that includes refills, those "refill options" are electronically stored in a data base and only a single prescription order is sent on to the selected pharmacy for fulfillment. Therefore, when the time comes to refill the prescription, the patient, not the initial filling pharmacy, has control over those refill options. For example, the patient may elect to send the first refill order to a pharmacy near the patient's home, the second refill to a pharmacy near the patient's office, and the third refill to an Internet-based pharmacy. This allows the patient to shop for the greatest convenience and/or value for refill prescriptions, rather than being tied to the pharmacy that filled the initial order. The system also prevents a patient to refill a prescription before the stated time allotment on the previous prescription order has expired. In other words, a patient can't send refills to more than one

pharmacy at a time, nor can he submit a refill order before his current order (for example, a 30-day medication supply) passes its 30-day waiting period.

In the process of Fig. 32, a prescription with refills exists within the computer system 50. The system transmits an order for a single medication  
5 supply (meaning without refills) to a pharmacy 651. The pharmacy may be a brick and mortar pharmacy or may be an Internet based pharmacy. The transmission may occur electronically using a communications network. The system stores the refills in a data base for future use 652. If the patient requests refills 653, the system transmits refills to a patient-selected  
10 pharmacy 654 which may be a different pharmacy than the pharmacy that filled the original medication supply and may be different from the pharmacy that filled other refills of this prescription. If there are refills left on the prescription 655, the process repeats at step 651. Otherwise the process ends 656.

15 Using the foregoing, the invention may be implemented using standard programming or engineering techniques including computer programming software, firmware, hardware or any combination or subset thereof. Any such resulting program, having a computer readable program code means, may be embodied or provided within one or more computer readable or usable media,  
20 thereby making a computer program product, i. e. an article of manufacture, according to the invention. The computer readable media may be, for instance a fixed (hard) drive, disk, diskette, optical disk, magnetic tape, semiconductor memory such as read-only memory (ROM), or any transmitting/receiving medium such as the Internet or other communication network or link. The

article of manufacture containing the computer programming code may be made and/or used by executing the code directly from one medium, by copying the code from one medium to another medium, or by transmitting the code over a network.

5           An apparatus for making, using or selling the invention may be one or more processing systems including, but not limited to, a central processing unit (CPU), memory, storage devices, communication links, communication devices, server, I/O devices, or any sub-components or individual parts of one or more processing systems, including software, firmware, hardware or any  
10 combination or subset thereof, which embody the invention as set forth in the claims.

User input may be received from the keyboard, mouse, pen, voice, touch screen, or any other means by which a human can input data to a computer, including through other programs such as application programs.

15           Although the present invention has been described in detail with reference to certain preferred embodiments, it should be apparent that modifications and adaptations to those embodiments may occur to persons skilled in the art without departing from the spirit and scope of the present invention as set forth in the following claims.

20

What is claimed is:

- 1 1. A computer system for displaying targeted healthcare information to a  
2 computer user comprising:
  - 3 a. a healthcare product information selecting computer;
  - 4 b. a plurality of devices for enabling entry of healthcare related  
5 information into the system;
  - 6 c. a database for storing the healthcare related information and  
7 healthcare product information connected to the healthcare product  
8 information selecting computer; and
  - 9 d. a communications network for transmitting healthcare related  
10 information from at least one of the plurality of devices to the selecting  
11 computer for storage in the database, wherein the selecting computer  
12 selects healthcare product information for display to the user based on  
13 the healthcare related information entered from at least one of the  
14 plurality of devices.
- 1 2. A computer system for displaying targeted healthcare advertisements to a  
2 computer user comprising:
  - 3 a. an advertising selecting computer;
  - 4 b. a plurality of devices for enabling entry of healthcare related  
5 information into the system;
  - 6 c. a database for storing the healthcare related information and  
7 advertising information connected to the advertising selecting  
8 computer; and

9 d. a communications network for transmitting healthcare related  
10 information from the devices to the selecting computer for storage in  
11 the database, wherein the advertising selecting computer compares  
12 the healthcare related information to the advertising information and  
13 selects advertising information for display to the user that is related to  
14 the healthcare related information entered from at least one of the  
15 plurality of devices.

1 3. The system of claim 2 wherein the healthcare related information  
2 comprises information received from a healthcare group consisting of  
3 healthcare providers, patients, healthcare service organizations,  
4 pharmaceutical companies, healthcare product and service vendors,  
5 pharmacies, medical facilities, healthcare information services, medical  
6 record databases, government agencies, non-profit organizations, health  
7 research organizations and billing companies.

1 4. The system of claim 2 further comprising a database of stored non-  
2 healthcare related information connected to the advertising selecting  
3 computer wherein the selecting computer compares the healthcare related  
4 information and the non-healthcare information to the advertising  
5 information and selects advertising information for display to the user that  
6 is related to the non-healthcare information.

1 5. The system of claim 2 wherein at least one of the plurality of devices is a  
2 wireless portable computer device.

1 6. The system of claim 2 wherein the devices are selected from the group  
2 consisting of web TV devices, personal digital assistant devices, personal

3 computers, handheld portable computers, portable computers, wireless  
4 telephone devices and wireless personal access devices.

1 7. The system of claim 3 further comprising the advertising selecting  
2 computer constructs a medical record for a patient using healthcare  
3 information selected from at least one of the healthcare group and  
4 transmits the medical record via the communications network to a  
5 computer user.

1 8. The system of claim 2 further comprising the advertising selecting  
2 computer transmits a pharmaceutical advertisement to at least one of the  
3 plurality of devices for display via the communications network and in  
4 response to a healthcare provider user selecting the displayed  
5 pharmaceutical advertisement, a prescription for a patient is initiated.

1 9. The system of claim 8 further comprising initializing parameters of the  
2 prescription to values based on patient medical information.

1 10. The system of claim 2 further comprising the advertising selecting  
2 computer transmits a pharmaceutical advertisement to at least one of the  
3 plurality of devices for display via the communications network and in  
4 response to a healthcare provider user selecting the displayed  
5 pharmaceutical advertisement, a prescription for a patient is automatically  
6 created.

1 11. The system of claim 2 further comprising the advertising selecting  
2 computer calculates a revenue amount to be paid to the healthcare  
3 provider for using the computer system.

- 1 12. The system of claim 2 further comprising the advertising selecting  
2 computer calculates a revenue amount to be paid to the healthcare  
3 provider for referring patients to a health information website.
- 1 13. The system of claim 2 wherein the communications network is selected  
2 from the group consisting of a global communications network, a  
3 communications inter-network, a wide area network, a local area network,  
4 a wireless telephone network, a satellite network, an interactive television  
5 network and a cable network.
- 1 14. A method of displaying targeted healthcare product information to a  
2 computer user comprising:  
3 a. using a medical information database, including patient medical  
4 information, and a healthcare product information database; and  
5 b. in response to a request from a client computer comparing the medical  
6 related information to the health care product information database and  
7 selecting healthcare product information to be displayed to the user  
8 that is related to the medical information.
- 1 15. The method of claim 14 wherein the user is selected from the group  
2 consisting of a patient and a healthcare provider.
- 1 16. The method of claim 14 wherein the healthcare product information is an  
2 advertisement.
- 1 17. The method of claim 14 wherein the healthcare product information is a  
2 pharmaceutical advertisement.
- 1 18. The method of claim 14 wherein the healthcare product information  
2 includes healthcare service information.



1 19. The method of claim 14 wherein the medical information database and  
2 patient medical information comprises information selected from the group  
3 consisting of health care provider information, patient medical records,  
4 patient prescription records, patient entered information, medical test  
5 ordering and test result records, and health information.

1 20. The method of claim 14 further comprising generating the medical  
2 information database using information entered by a plurality of users of  
3 the system.

1 21. The method of claim 20 wherein the data is organized by patient  
2 characteristics.

1 22. The method of claim 20 wherein the data is organized by healthcare  
2 provider characteristics.

1 23. The method of claim 20 wherein the medical information database  
2 contains a patient medical record created by the information entered by  
3 the plurality of users of the system.

1 24. The method of claim 23 wherein the patient medical record comprises  
2 information selected from the group consisting of a patient's medical  
3 condition, allergies, medications, physical examination results, test orders  
4 and results, health insurance enrollment and selected pharmacy.

1 25. A computer implemented method for managing health related information  
2 comprising:

3 a. using patient medical information and healthcare provider information  
4 collected from at least one of a plurality of sources;

5        b. selecting healthcare product advertisements for display to a computer  
6            user based on the patient medical information and healthcare provider  
7            information; and

8        c. transmitting the advertisements to a computer user for display.

1    26. The method of claim 25 wherein the plurality of sources selected from the  
2            group consisting of health care provider information, patient medical  
3            records, patient prescription records, patient entered information, medical  
4            test ordering and test result records, and health information.

1    27. The method of claim 25 wherein the product advertisements comprise  
2            pharmaceutical advertisements.

1    28. The method of claim 25 wherein at least one of the plurality of sources  
2            comprises collected user entered data and user actions as a user  
3            navigates through an electronic web page display.

1    29. The method of claim 25 wherein the pharmaceutical advertisement is for a  
2            drug.

1    30. The method of claim 29 further comprising displaying the pharmaceutical  
2            advertisement for a drug on a computer screen, allowing the healthcare  
3            provider to select the drug displayed and initiating an electronic  
4            prescription for the drug for a patient.

1    31. The method of claim 29 further comprising displaying the pharmaceutical  
2            advertisement for a drug on a computer screen, allowing the healthcare  
3            provider to select the drug displayed and automatically creating an  
4            electronic prescription for the drug for a patient.

1 32. The method of claim 29 further comprising displaying the pharmaceutical  
2 advertisement for a drug on a computer screen and allowing the  
3 healthcare provider to select the drug displayed and displaying more  
4 information about the pharmaceutical.

1 33. The method of claim 30 further comprising initializing parameters of the  
2 prescription to values based on the patient medical information.

1 34. The method of claim 30 wherein the electronic prescription is electronically  
2 sent to a patient-selected pharmacy.

1 35. The method of claim 34 further comprising if the prescription contains at  
2 least one refill, at least one prescription refill is not sent to the patient-  
3 selected pharmacy and is electronically stored for the patient.

1 36. The method of claim of claim 35 wherein the electronically stored  
2 prescription refill is sent to the patient-selected pharmacy upon request of  
3 the patient.

1 37. The method of claim 27 further comprising:

2 a. the patient medical information includes drugs the patient is allergic to;  
3 and

4 b. in the selecting step, filtering pharmaceutical advertisements for drugs  
5 the patient is allergic to prior to display.

1 38. The method of claim 37 wherein filtering comprises not displaying the  
2 drug.

1 39. The method of claim 37 wherein filtering comprises displaying the drug  
2 with a warning.

1 40. The method of claim 27 further comprising:

2 a. the patient medical information includes drugs for which the patient has  
3 had adverse reactions; and

4 b. in the selecting step, filtering pharmaceutical advertisements for drugs  
5 the patient has had adverse reactions.

1 41. The method of claim 27 further comprising:

2 a. the patient medical information includes drugs selected from the group  
3 consisting of drugs for which the patient has had an adverse reaction,  
4 drugs in the same class as drugs for which the patient has had an  
5 adverse reaction, drugs for which the patient's family has a history of  
6 adverse reactions, drugs for which genetic profiling has indicated the  
7 patient may have an adverse reaction, drugs which may interact  
8 adversely with drugs the patient is currently taking; and

9 b. in the selecting step, determining pharmaceutical advertisements for  
10 drugs from the group and filtering said advertisements.

1 42. The method of claim 41 wherein filtering comprises not displaying the  
2 advertisements for display.

1 43. The method of claim 41 wherein filtering comprises displaying the  
2 advertisement with a warning.

1 44. The method of claim 27 further comprising:

2 a. the patient medical information includes drugs the patient is currently  
3 taking; and

4 b. in the selecting step, filtering pharmaceutical advertisements for drugs  
5 that are not included in the formulary of the patient's insurance  
6 company.

1 45. The method of claim 29 further comprising prioritizing pharmaceutical  
2 advertisement display order according to an amount of revenue received  
3 for displaying each pharmaceutical advertisement.

1 46. The method of claim 29 further comprising prioritizing pharmaceutical  
2 advertisement display order according to an amount of revenue received  
3 for displaying pharmaceutical advertisements for pharmaceuticals from a  
4 selected company.

1 47. A computer implemented method for displaying targeted healthcare  
2 product information to a healthcare provider comprising:  
3 a. using healthcare information collected from a plurality of sources;  
4 b. selecting healthcare product information for display to a healthcare  
5 provider based upon information from at least one of the plurality of  
6 sources and the process the healthcare provider has selected from a  
7 computer display within a healthcare provider's computerized workflow  
8 process; and  
9 c. displaying the healthcare product information to the healthcare provider  
10 on the computer display during the workflow process.

1 48. The method of claim 47 wherein the healthcare product information is  
2 displayed to the healthcare provider in real-time.

1 49. The method of claim 47 wherein the healthcare product information  
2 comprises advertisements for medical products.

1 50. The method of claim 47 wherein the healthcare product information  
2 comprises advertisements for medical services.

- 1 51. The method of claim 49 wherein the medical products are  
2 pharmaceuticals.
- 1 52. The method of claim 51 wherein the pharmaceutical advertisements are  
2 for specific drugs.
- 1 53. The method of claim 47 wherein the computerized workflow process  
2 comprises processes selected from the group consisting of creating an  
3 electronic medical record for a patient, counseling the patient, reviewing  
4 the electronic medical record, updating the electronic medical record,  
5 creating an electronic prescription, selecting medical tests to be performed  
6 on the patient, reviewing results of medical tests performed on the patient,  
7 reviewing medical reference information and electronically annotating  
8 medical reference information.
- 1 54. The method of claim 47 wherein the healthcare information is selected  
2 from the group consisting of patient medical information and healthcare  
3 provider information.
- 1 55. The method of claim 47 wherein:  
2 a. the plurality of sources further comprise information from at least one of  
3 the sources selected from the group consisting of a patient medical  
4 record, patient-entered information, healthcare provider entered patient  
5 information, health information, medical facility entered patient  
6 information, pharmacy information and insurance company entered  
7 patient information; and  
8 b. in the selecting step, selecting healthcare product information for  
9 display to the healthcare provider based upon patient medical

10 information, healthcare provider information, and at least one of the  
11 plurality of sources in step a and the process the healthcare provider  
12 has selected within healthcare provider's computerized workflow  
13 process.

1 56. The method of claim 47 further comprising:

- 2 a. automatically selecting healthcare information from at least one of the  
3 plurality of sources, wherein said sources accessed through a global  
4 communications network, based on patient medical information and  
5 healthcare provider information;
- 6 b. notifying the healthcare provider of the selected healthcare information;  
7 and
- 8 c. allowing the healthcare provider to send the selected healthcare  
9 information to a patient recipient through the global communications  
10 network.

1 57. The method of claim 47 further comprising:

- 2 a. allowing a healthcare provider to select healthcare information from the  
3 plurality of sources accessed through a global communications  
4 network;
- 5 b. allowing the healthcare provider to electronically annotate the  
6 healthcare information for a recipient;
- 7 c. merging the healthcare information and the electronic annotation into a  
8 information file; and
- 9 d. electronically sending the merged information to the patient through a  
10 global communications network for display to a recipient.

- 1 58. A computer implemented method for displaying targeted healthcare  
2 product information to a patient comprising:  
3 a. selecting healthcare product information for display to a patient based  
4 on the patient medical information and the healthcare provider  
5 information from at least one of a plurality of sources; and  
6 b. transmitting the healthcare product information for display to the  
7 patient.
- 1 59. The method of claim 58 further comprising selecting healthcare product  
2 information for display to a patient based on the patient medical  
3 information, the healthcare provider information and patient-entered data.
- 1 60. The method of claim 58 further comprising displaying the healthcare  
2 product information on a computer display transmitted to the user via a  
3 global communications network.
- 1 61. The method of claim 60 further comprising customizing information on the  
2 display based on the patient medical information, the healthcare provider  
3 information and the patient-entered data.
- 1 62. A computer system for displaying targeted healthcare product information  
2 to a computer user comprising:  
3 a. a health information manager computer program for accepting  
4 information from a plurality of electronic sources accessed through a  
5 global communications network and organizing the information from  
6 the plurality of sources to create patient medical records; and



7       b. using the information from at least one of the plurality of sources to  
8           select healthcare product advertisements for display to a user based  
9           on the patient medical records and healthcare provider records.

1   63. The system of claim 62 wherein the patient medical records comprise  
2       information selected from the group consisting of patient history and  
3       examination information, test order information, test result information,  
4       medication information and patient-entered information.

1   64. A computer-implemented method of displaying targeted healthcare  
2       product information to a computer user comprising:

3       a. using stored medical information from a plurality of sources comprising:

4           i. for a selected patient, a patient's medical history;

5           ii. healthcare provider information;

6           iii. prescription writing habits of a healthcare provider;

7       b. associating the medical information from the at least one of the plurality  
8           of sources with stored healthcare advertisement information to select  
9           an advertisement for display to a user that is related to the at least one  
10          of the plurality of sources; and

11      c. transmitting the healthcare advertisement for electronically displaying  
12          to the user.

1   65. The system of claim 64 wherein the patient's medical history comprises  
2       information selected from the group consisting of patient history and  
3       examination information, patient test results information, patient  
4       prescription information, patient-entered information and other information  
5       relating to medical condition of the patient.

1 66. The method of claim 29 further comprising computing a revenue amount to  
2 be paid to the healthcare provider for displaying targeted healthcare  
3 information.

1 67. The method of claim 29 further comprising providing revenue to the  
2 healthcare provider based upon the number of patients of the healthcare  
3 provider that visit at least one website.

1 68. The method of claim 29 further comprising providing revenue to the  
2 healthcare provider for using the computer system.

1 69. A computer-implemented method for managing prescription refills  
2 comprising:

3 a. entering a prescription into a computer program;

4 b. if the prescription has at least one refill, storing by the computer  
5 program the at least one refill;

6 c. transmitting by the computer program the at least one refill to a patient-  
7 selected pharmacy;

8 d. updating the number of remaining refills and storing any remaining  
9 refills by the computer program; and

10 e. repeating steps c and d until no refills remain.

1 70. The method of claim 69 wherein the refill is transmitted to a patient-  
2 selected pharmacy upon a request by the patient.

1 71. The method of claim 69 wherein the refill is transmitted to a patient-  
2 selected pharmacy prior to the patient using all of a current prescription.

1 72. A software program embodied on a computer-readable medium  
2 incorporating the method as recited in claim 14.

1 73. A software program embodied on a computer-readable medium

2 incorporating the method as recited in claim 25.

1 74. A software program embodied on a computer-readable medium

2 incorporating the method as recited in claim 30.

1 75. A software program embodied on a computer-readable medium

2 incorporating the method as recited in claim 47.

1 76. A software program embodied on a computer-readable medium

2 incorporating the method as recited in claim 58.

1 77. A software program embodied on a computer-readable medium

2 incorporating the method as recited in claim 62.

1 78. A software program embodied on a computer-readable medium

2 incorporating the method as recited in claim 69.

1

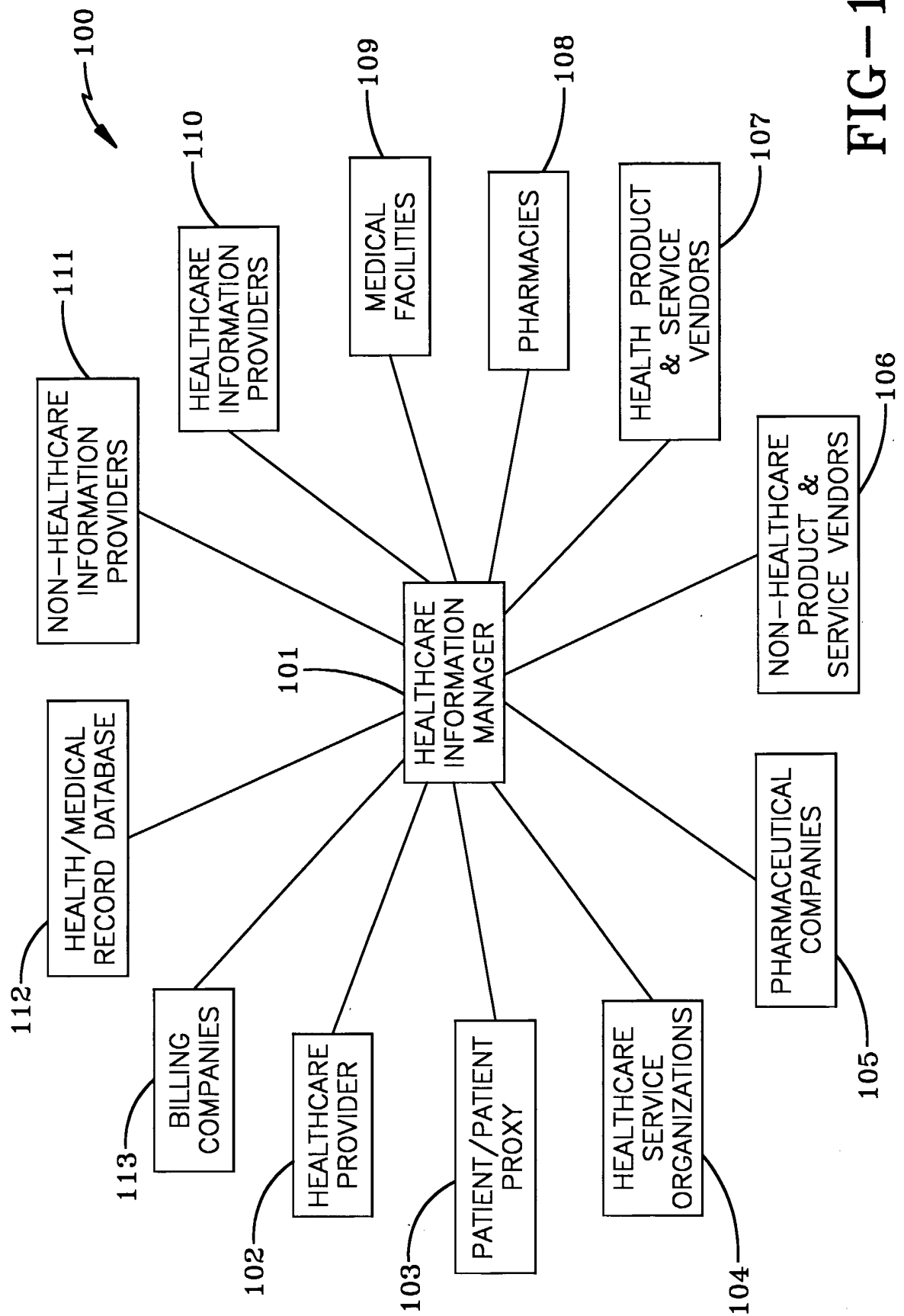

FIG-1

<p>HEALTHCARE PROVIDER:          PHYSICIAN          PHYSICIAN OFFICE STAFF AND HOSPITAL STAFF NURSE          RESPIRATORY THERAPIST          EMT/EMT-P (PARAMEDIC)          TECHNICAL ASSISTANT          FRONT OFFICE PERSONNEL (RECEPTIONIST, ETC.)          PHYSICIAN ASSISTANT (PA)          CERTIFIED REGISTERED NURSE          PRACTITIONER (CRNP)          CERTIFIED REGISTERED NURSE MIDWIFE          CERTIFIED MEDICAL ASSISTANT (CMA)</p>	<p>PATIENT:          PATIENT          PATIENT PROXY          RELATIVE          EXECUTOR          GUARDIAN          HEALTHCARE PROVIDER</p>	<p>HEALTHCARE SERVICES MANAGEMENT SYSTEMS:          HMOs (HEALTH MANAGEMENT ORGANIZATIONS AND OTHER INSURERS)          PBMs (PHARMACY BENEFIT MANAGERS/MANAGEMENT COMPANIES)          PPMs (PHYSICIAN PRACTICE MANAGERS/MANAGEMENT COMPANIES)          GOVERNMENT DATABASES (U.S., STATE, COUNTY, CITY)          MEDICAID          MEDICARE          HOSPICE SYSTEMS          COMMERCIAL EMPLOYEES WHO ARE SELF-INSURED          COMMERCIAL INDEMNITY HEALTH INSURANCE PAYORS          PSOS (PROVIDER SPONSORED ORGANIZATIONS TAKING INSURANCE RISK AND ACTING AS PAYOR)          GOVERNMENT ENTITIES</p>
<p><u>102</u></p>	<p><u>103</u></p>	<p><u>104</u></p>

FIG-2A

<p>PHARMACEUTICAL COMPANIES:                  MANUFACTURERS                  DISTRIBUTORS                  MARKETING COMPANIES (INCLUDING                  INDEPENDENT, 3rd PARTY                  COMPANIES REPRESENTING                  PHARMACEUTICAL COMPANIES)                  ADVERTISING AGENCIES HANDLING                  PHARMACEUTICAL ACCOUNTS                  PUBLIC RELATIONS COMPANIES                  HANDLING PHARMACEUTICAL                  ACCOUNTS</p>	<p>NON-HEALTHCARE PRODUCT &amp;                  SERVICE VENDORS:                  FINANCIAL INSTITUTIONS                  ONLINE TRADING COMPANIES                  RETAIL MERCHANTS                  AUCTION COMPANIES                  EDUCATIONAL INSTITUTIONS AND                  COMPANIES                  NON-MEDICAL CHARITIES                  GOVERNMENT ENTITIES</p>	<p>HEALTH PRODUCT &amp;                  SERVICE VENDORS:                  NON-PHARMACEUTICAL                  PRODUCT AND SERVICE                  MANUFACTURERS,                  DISTRIBUTORS, RESELLERS,                  DISEASE PREVENTION,                  SPECIFIC AND/OR                  GENERAL CONDITIONS,                  ILLNESSES, DISEASES,                  INJURIES                  GOVERNMENT ENTITIES</p>
<p><u>105</u></p>	<p><u>106</u></p>	<p><u>107</u></p>

FIG-2B

<p>PHARMACIES:                  RETAIL PHARMACIES                  CHAIN                  INDEPENDENT                  MASS MERCHANDISING                  MAIL ORDER                  INTERNET BASED                  PBM FULFILLMENT CENTERS                  HOSPITAL BASED                  CLINIC/OUTPATIENT BASED</p>	<p>MEDICAL FACILITIES:                  HOSPITALS                  PHYSICIAN OFFICES                  TREATMENT CENTERS                  OUTPATIENT CLINICS                  LABORATORIES                  IMAGING CENTERS                  MOBILE TESTING FACILITIES                  MOBILE TREATMENT FACILITIES                  SURGERY CENTERS                  REHABILITATION CLINICS                  MEDICAL RECORDS CENTERS                  OCCUPATIONAL HEALTH CENTERS                  CANCER CENTERS                  PAIN MANAGEMENT CENTERS                  HOSPICES                  SKILLED NURSING FACILITIES                  NURSING HOMES                  SUBACUTE HOSPITALS/FACILITIES                  PHYSICAL THERAPY CENTERS                  GOVERNMENT MEDICAL FACILITIES</p>	<p>HEALTH INFORMATION PROVIDERS:                  HEALTH INFORMATION WEB SITES/PORTALS                  PROFESSIONAL                  CONSUMER-ORIENTED                  3rd PARTY INFORMATION SUPPLY                  COMPANIES (e.g. HEALTHSCOUT)                  PUBLIC HEALTH INSTITUTIONS                  NATIONAL INSTITUTES OF HEALTH                  CENTERS FOR DISEASE CONTROL                  CHARITIES                  NON-PROFIT ORGANIZATIONS                  PROFESSIONAL SOCIETIES                  AMERICAN MEDICAL SOCIETY                  AMERICAN COLLEGE OF CARDIOLOGY</p>
<p style="text-align: right;"><u>108</u></p>	<p style="text-align: right;"><u>109</u></p>	<p style="text-align: right;"><u>110</u></p>

FIG-2C

<p>NON-HEALTHCARE INFORMATION PROVIDERS: CONSUMER REPORTING COMPANIES PRICE COMPARISON COMPANIES CHARITABLE ORGANIZATIONS INFORMATION-RELATED WEB SITES GOVERNMENTAL ENTITIES</p> <p style="text-align: right;"><u>111</u></p>	<p>HEALTH/MEDICAL RECORD DATABASES: PersonaldMD.com drkoop.com MedicalLogic DATA CENTER RECORD STORAGE</p> <p style="text-align: right;"><u>112</u></p>	<p>BILLING COMPANIES: MEDICAL BILLERS INSURANCE COMPANIES PRODUCT BILLERS THIRD-PARTY TRANSACTION COMPANIES</p> <p style="text-align: right;"><u>113</u></p>	<p>HEALTHCARE INFORMATION MANAGEMENT SYSTEM (RECARÉ DATA CENTER): ON-SITE STORAGE SYSTEMS ON-SITE PROCESSING SYSTEMS OFF-SITE STORAGE SYSTEMS OFF-SITE PROCESSING SYSTEMS THIRD-PARTY STORAGE SYSTEMS THIRD-PARTY PROCESSING SYSTEMS COLLOCATED STORAGE SYSTEMS COLLOCATED PROCESSING SYSTEMS</p> <p style="text-align: right;"><u>101</u></p>
--	---	--	--

FIG-2D



6/52

FIG-3

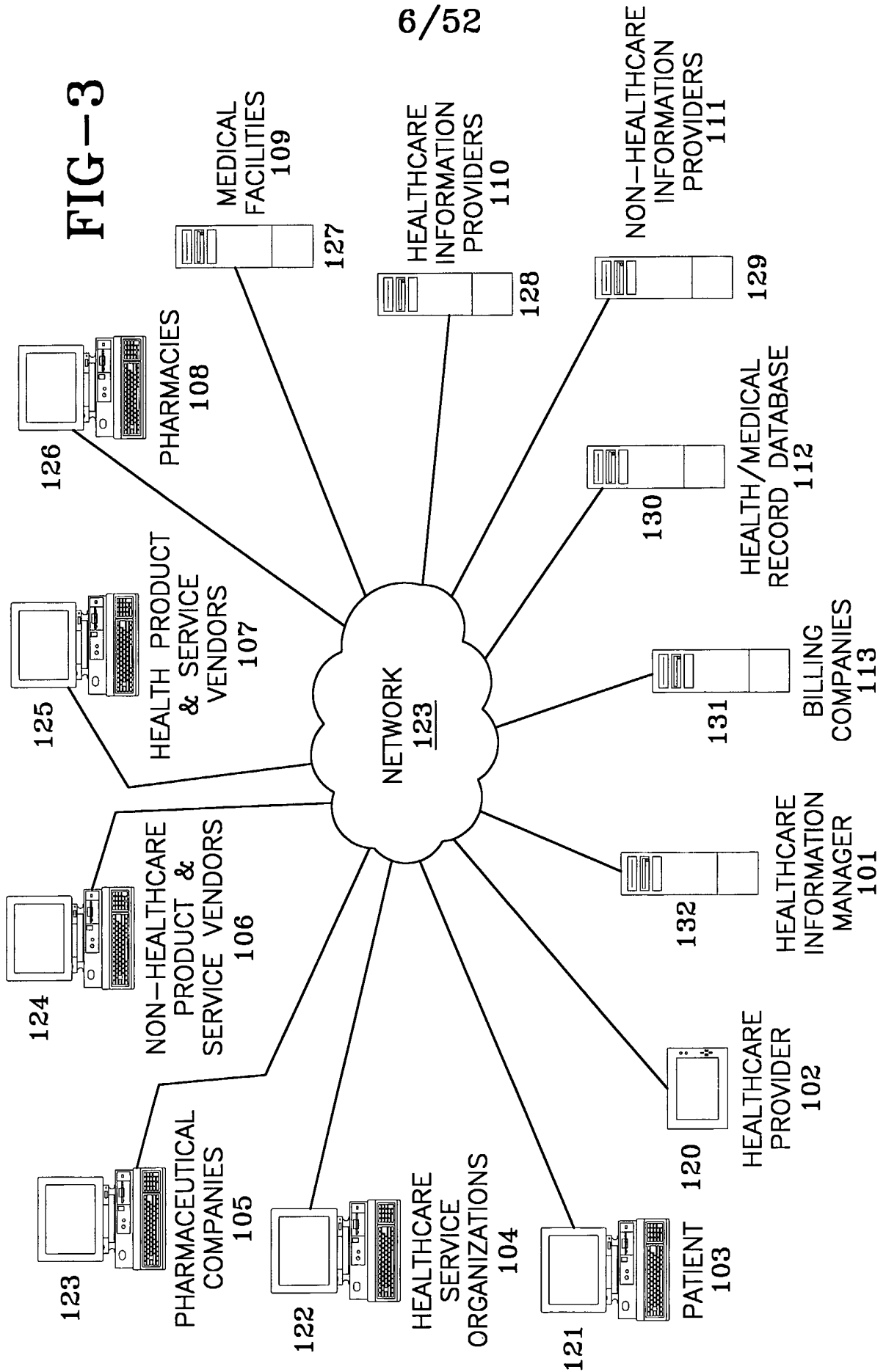

HEALTHCARE PROVIDER:  
 PATIENT'S MEDICAL RECORD INFORMATION  
 CHIEF COMPLAINT/REASON FOR VISIT  
 PFSH (PAST, FAMILY, AND SOCIAL HISTORY)  
 MEDICATIONS  
 ALLERGIES  
 ROS (REVIEW OF SYSTEMS)  
 PHYSICAL EXAMINATION FINDINGS  
 IMMUNIZATIONS  
 COUNSELING AND HEALTH EDUCATION  
 DIAGNOSES  
 PHARMACEUTICAL OR OTHER RELEVANT ADVERTISEMENTS  
 RELEVANT HEALTH INFORMATION (JOURNALS, ARTICLES, NEWS, TEXTS, UPDATES, ALERTS, ETC.)  
 PROMPTS FOR SENDING PATIENT INFORMATION  
 LAB ORDERS AND RESULTS  
 PRESCRIPTION ORDERS, REFILL REQUESTS, REFILL CONFIRMATIONS, ETC.  
 WARNINGS, ALERTS, CORRECTION REQUESTS, CLARIFICATION REQUESTS, CHANGE REQUESTS  
 PRESCRIPTION PICK-UP CONFIRMATION  
 TEST ORDERS, RESULTS, AND INTERPRETATIONS  
 EKGs  
 X-RAYS  
 MRIs  
 CTs

500

TO FIG-4B

FIG-4A

8/52

FROM FIG--4A

CONSULT INFORMATION, REQUESTS, REPORTS  
REFERRAL INFORMATION, REQUESTS, REPORTS  
CME (CONTINUING MEDICAL EDUCATION) INFORMATION (COURSES, PROGRAMS, TEST EVALUATIONS,  
CREDITS, CERTIFICATES)  
PATIENT-ENTERED TOPICS OF INTEREST  
FORMULARY INFORMATION  
PATIENT INSURANCE ENROLLMENT STATUS  
BILLING AND CODING INFORMATION  
PERSONAL SCHEDULING INFORMATION, ALERTS, ETC.  
ADMINISTRATIVE NOTICES  
PHARMACOPOEIA INFORMATION  
VIDEO (DOWNLOADABLE, LIVE PERSON-TO-PERSON/CONFERENCE)  
AUDIO (REALPLAYER, MP3, LIVE PERSON-TO-PERSON/CONFERENCE) 500

FIG--4B

PATIENT PROXY:	
GENERAL PATIENT INFORMATION	
DEMOGRAPHICS (NAME, ADDRESS, PHONE, EMAIL, ETC.)	
EMPLOYER AND OCCUPATION INFORMATION	
NAME OF INSURANCE COMPANY AND POLICY OR GROUP NUMBER	
PHARMACY SELECTION CRITERIA	
PHARMACY SELECTION	
INFORMATION RELATED TO PHARMACY SELECTION (MAPS, DIRECTIONS)	
PATIENT'S MEDICAL RECORD INFORMATION	
CHIEF COMPLAINT/REASON FOR VISIT	
PFSH (PAST, FAMILY, AND SOCIAL HISTORY)	
MEDICATIONS	
ALLERGIES	
ROS (REVIEW OF SYSTEMS)	
PHYSICAL EXAMINATION FINDINGS	
DIAGNOSES	
PHARMACEUTICAL OR OTHER RELEVANT ADVERTISEMENTS	
RELEVANT HEALTH INFORMATION (JOURNALS, ARTICLES, NEWS, UPDATES, ALERTS)	
PROMPTS FOR SENDING INFORMATION TO OTHERS	
MESSAGES FROM PHYSICIAN/PHYSICIAN PROXIES	
SELECTED LAB ORDERS (URINALYSIS, TB SCREEN, ETC.) AND RESULTS	<u>501</u>

TO FIG-4D

FIG-4C

10/52

FROM FIG-4C

PRESCRIPTION REFILL REQUESTS, REFILL CONFIRMATIONS, ETC.  
 WARNINGS, ALERTS, CORRECTION REQUESTS, CLARIFICATION REQUESTS, CHANGE REQUESTS  
 PRESCRIPTION PICK-UP CONFIRMATION  
 TEST RESULTS AND INTERPRETATIONS  
 EKGs  
 X-RAYS  
 MRIs  
 CTs  
 CONSULT INFORMATION, REPORTS  
 REFERRAL INFORMATION, REPORTS  
 INFORMATIVE PROGRAMS (MEDICAL, HEALTHCARE, WELLNESS, EXERCISE, ETC)  
 PATIENT-ENTERED TOPICS OF INTEREST  
 FORMULARY INFORMATION  
 PATIENT INSURANCE ENROLLMENT STATUS  
 PERSONAL SCHEDULING INFORMATION, ALERTS, ETC.  
 PHARMACOPOEIA INFORMATION  
 VIDEO (DOWNLOADABLE, LIVE PERSON-TO-PERSON/CONFERENCE)  
 AUDIO (REALPLAYER, MP3, LIVE PERSON-TO-PERSON/CONFERENCE)

501

FIG-4D

<p>HEALTHCARE SERVICES ORGANIZATIONS:                  FORMULARY INFORMATION                  ENROLLMENT INFORMATION                  REGULATION INFORMATION                  BILLING INFORMATION                  VIDEO (DOWNLOADABLE, LIVE                  PERSON-TO-PERSON/CONFERENCE)                  AUDIO (REALPLAYER, MP3, LIVE                  PERSON-TO-PERSON/CONFERENCE)</p>	<p>PHARMACEUTICAL COMPANIES:                  ADVERTISEMENTS                  PROMOTIONAL MATERIALS                  (PRINTABLE BROCHURES, ETC.)                  WHITE PAPERS                  PRESCRIBING INFORMATION                  REPORTS ON AD EFFECTIVENESS,                  ROI, PHYSICIAN PRESCRIBING                  HABITS, ETC.                  WARNINGS AND ALERTS/RECALLS                  JOURNAL ARTICLES, TEXTBOOKS                  (AND/OR EXCERPTS), ETC.                  SCHEDULING INFORMATION                  PRESCRIBING HABITS                  VIDEO (DOWNLOADABLE, LIVE                  PERSON-TO-PERSON/CONFERENCE)                  AUDIO (REALPLAYER, LIVE                  PERSON-TO-PERSON/CONFERENCE)</p>	<p>NON-HEALTHCARE                  PRODUCT AND SERVICE                  VENDORS:                  FINANCIAL INFORMATION                  RETAIL INFORMATION                  TRANSACTION INFORMATION                  ADVERTISEMENTS                  EDUCATIONAL INFORMATION</p>
<p><u>502</u></p>	<p><u>503</u></p>	<p><u>504</u></p>

FIG-4E

<p>HEALTHCARE PRODUCT AND SERVICE VENDORS: ADVERTISEMENTS                  INFORMATION (PRODUCT INFORMATION, SERVICE INFORMATION)                  REPORTS ON AD EFFECTIVENESS, ROI, CONSUMER BUYING HABITS, ETC.                  VIDEO (DOWNLOADABLE, LIVE PERSON-TO-PERSON/CONFERENCE)                  AUDIO (REALPLAYER, MP3, LIVE PERSON-TO-PERSON/CONFERENCE)                  FINANCIAL INFORMATION                  RETAIL INFORMATION                  TRANSACTION INFORMATION                  EDUCATIONAL INFORMATION</p>	<p>PHARMACIES: ADVERTISEMENTS                  LOGOS                  PHARMACY SELECTION AND ROUTING INFORMATION                  VIDEO (DOWNLOADABLE, LIVE PERSON-TO-PERSON/CONFERENCE)                  AUDIO (REALPLAYER, MP3, LIVE PERSON-TO-PERSON/CONFERENCE)                  PRESCRIPTION INFORMATION REPORTS ON AD EFFECTIVENESS, ROI, ETC.                  ALERTS/WARNINGS REQUESTS FOR CLARIFICATION, REFILLS, SUBSTITUTIONS, ETC.                  TRANSACTION INFORMATION                  COMPLIANCE REPORTS (e.g. PATIENT PICKUP INFORMATION)</p>	<p>MEDICAL FACILITIES: MEDICAL RECORDS                  LAB ORDERS AND REPORTS                  PRESCRIPTION ORDERS, REFILL REQUESTS, REFILL CONFIRMATIONS, ETC.                  TEST ORDERS, RESULTS, AND INTERPRETATIONS (EKGS, MRIs, X-RAYS, CTs ETC.)                  CONSULT INFORMATION, REQUESTS, AND REPORTS                  REFERRAL INFORMATION, REQUESTS, AND REPORTS                  HEALTH INFORMATION (EDUCATIONAL MATERIALS, NEWSLETTERS) ADVERTISEMENTS                  INSURANCE INFORMATION                  CME (CONTINUING MEDICAL EDUCATION) INFORMATION                  BILLING INFORMATION                  VIDEO (DOWNLOADABLE, LIVE PERSON-TO-PERSON/CONFERENCE)                  AUDIO (REALPLAYER, MP3, LIVE PERSON-TO-PERSON/CONFERENCE)                  PLUS ALL ITEMS LISTED UNDER HEALTHCARE PROVIDER NOT EXPLICITLY MENTIONED HERE</p>
<p><u>505</u></p>	<p><u>506</u></p>	<p><u>507</u></p>

FIG-4F

<p>HEALTH INFORMATION PROVIDERS: HEALTH INFORMATION NEWS ARTICLES BOOKS VIDEO (DOWNLOADABLE, LIVE, PERSON-TO- PERSON/CONFERENCE ADVERTISEMENTS ALL ITEMS LISTED IN MEDICAL FACILITIES</p> <p style="text-align: right;"><u>508</u></p>	<p>NON-HEALTH INFORMATION PROVIDERS: INFORMATION NEWS ARTICLES BOOKS VIDEO (DOWNLOADABLE, LIVE, PERSON-TO- PERSON/CONFERENCE ADVERTISEMENTS ALL ITEMS LISTED IN MEDICAL FACILITIES</p> <p style="text-align: right;"><u>509</u></p>
<p>HEALTH/MEDICAL RECORD DATABASES: ALL ITEMS LISTED UNDER HEALTHCARE PROVIDER</p> <p style="text-align: right;"><u>510</u></p>	<p>BILLING COMPANIES: ALL ITEMS LISTED UNDER HEALTHCARE PROVIDER AND MEDICAL FACILITIES</p> <p style="text-align: right;"><u>511</u></p>
<p>HEALTHCARE INFORMATION MANAGER: ALL ITEMS UNDER HEALTHCARE PROVIDER, PATIENT, HEALTHCARE SERVICES ORGANIZATIONS, PHARMACEUTICAL COMPANIES, NON-HEALTHCARE PRODUCT AND SERVICE VENDORS, HEALTH PRODUCT AND SERVICE VENDORS, PHARMACIES, MEDICAL FACILITIES, HEALTH INFORMATION PROVIDERS, NON-HEALTHCARE INFORMATION PROVIDERS, HEALTH/MEDICAL RECORD DATABASE, AND BILLING COMPANIES</p> <p style="text-align: right;"><u>512</u></p>	

FIG-4G



14/52

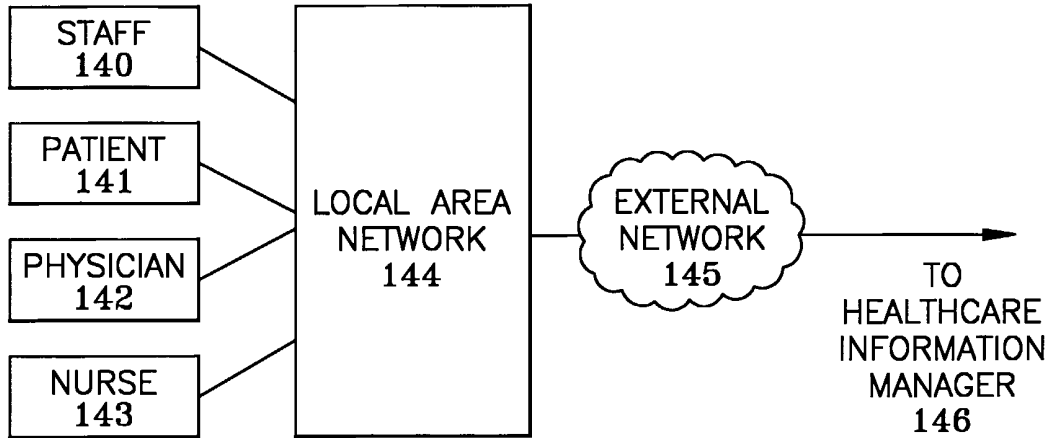

FIG-5A

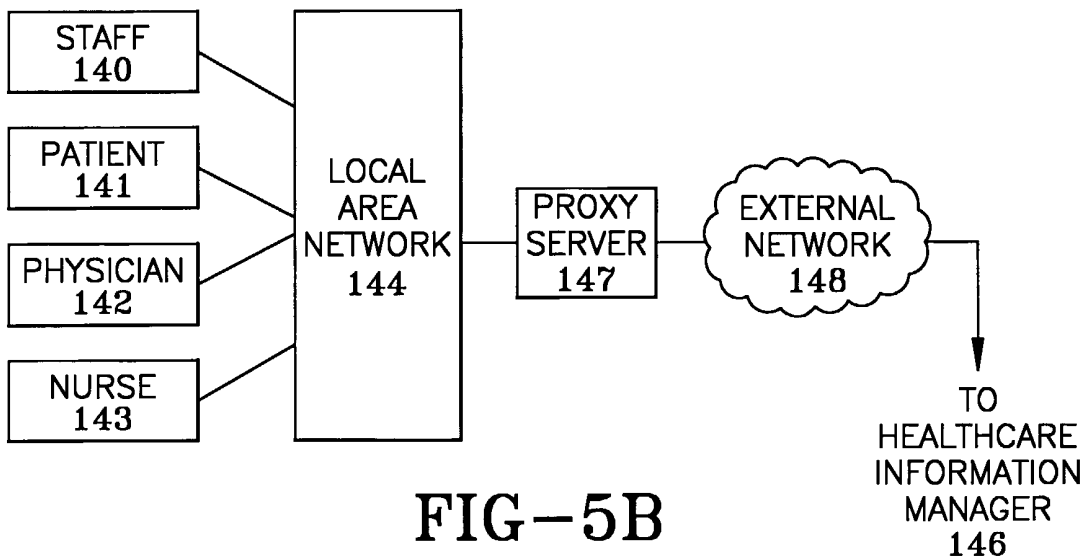

FIG-5B

15/52

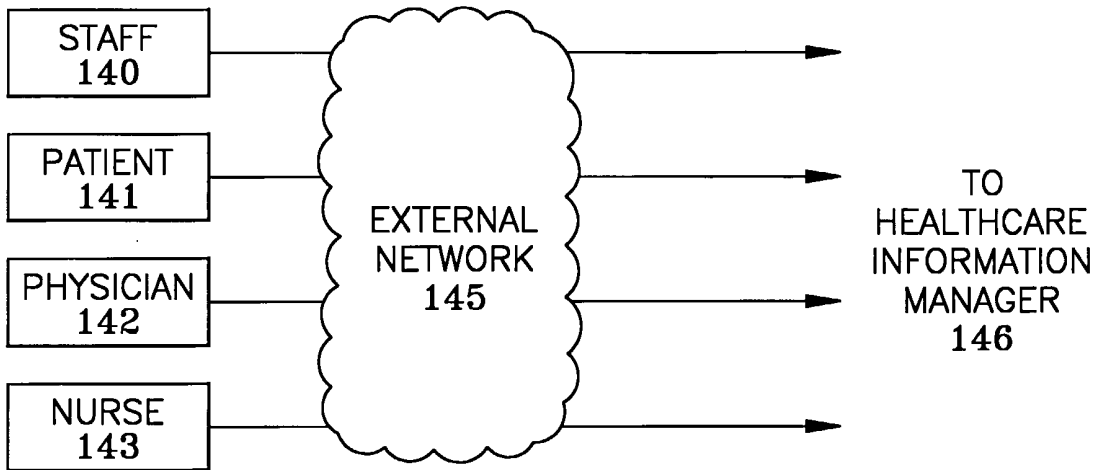

FIG-5C

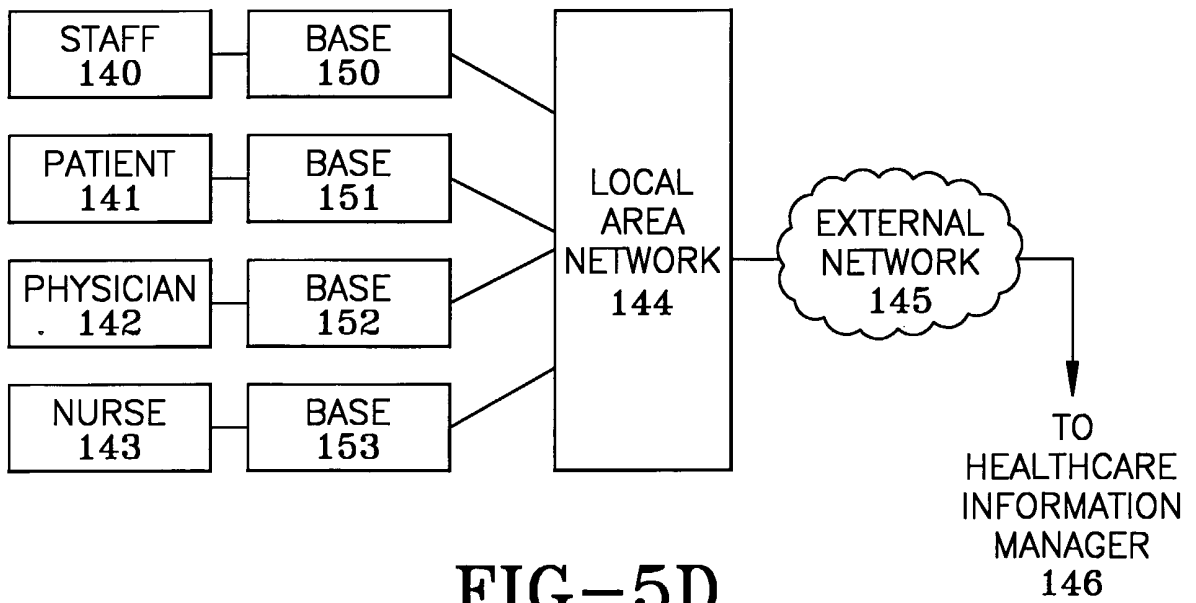

FIG-5D

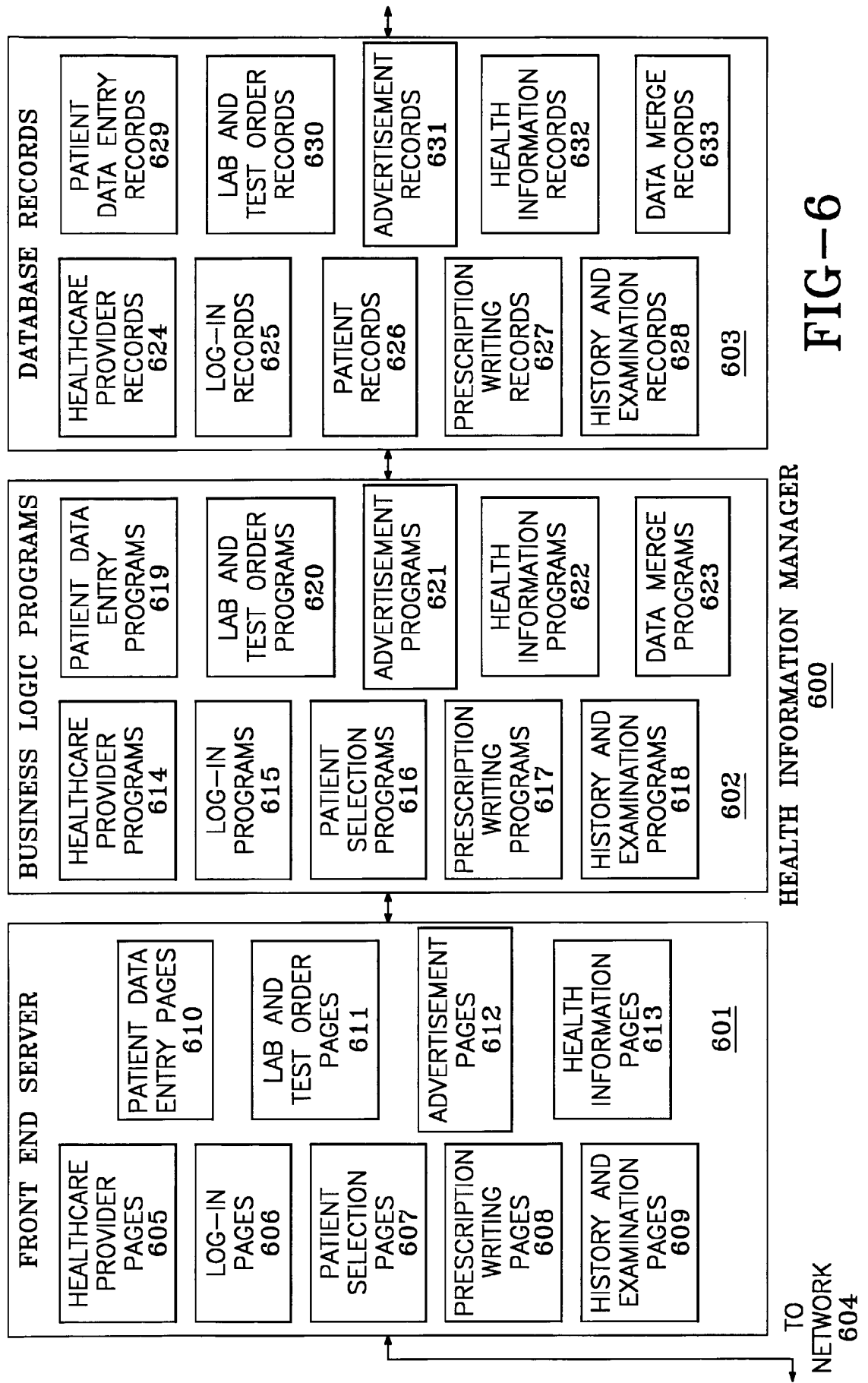

FIG-6

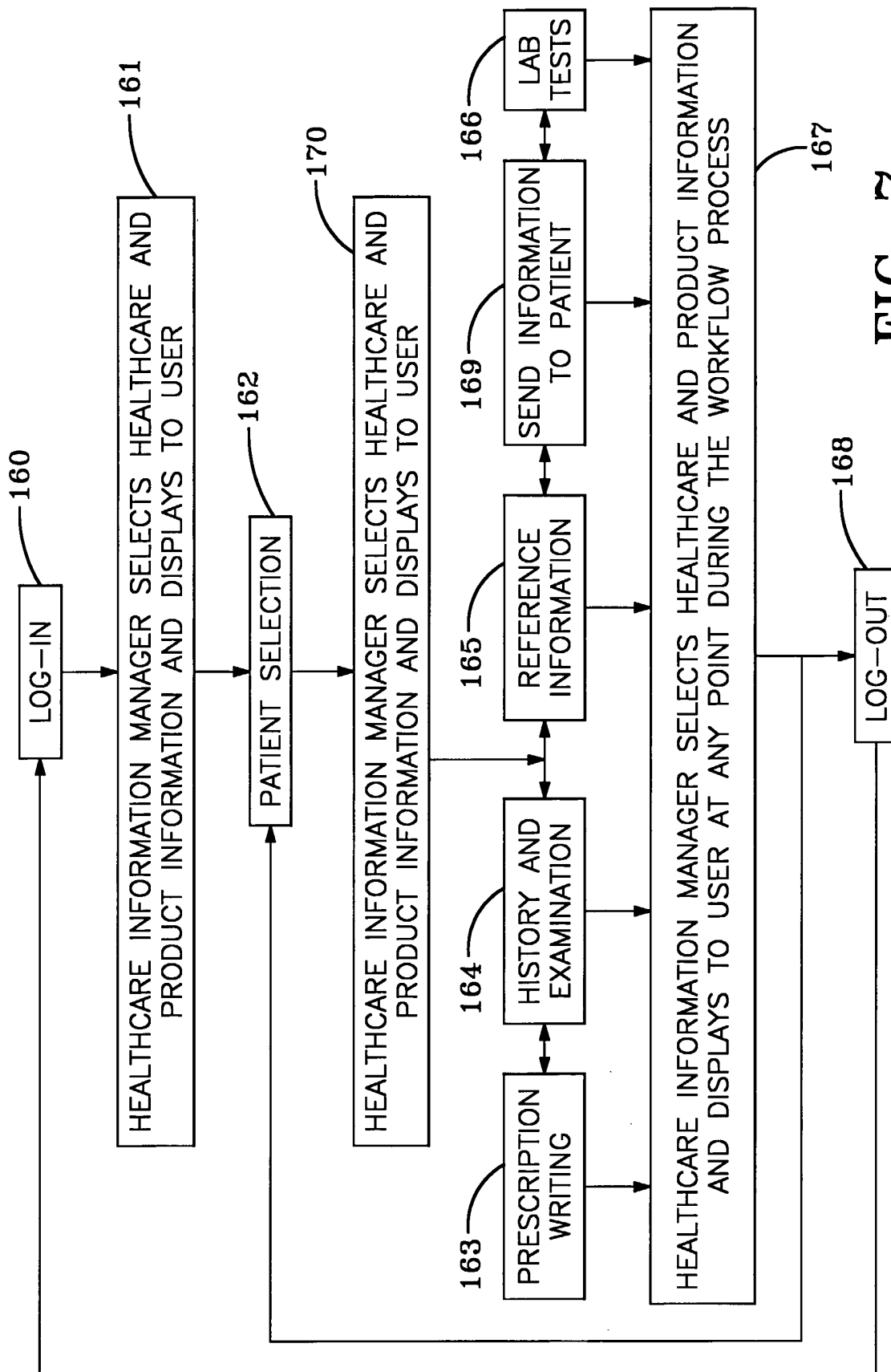
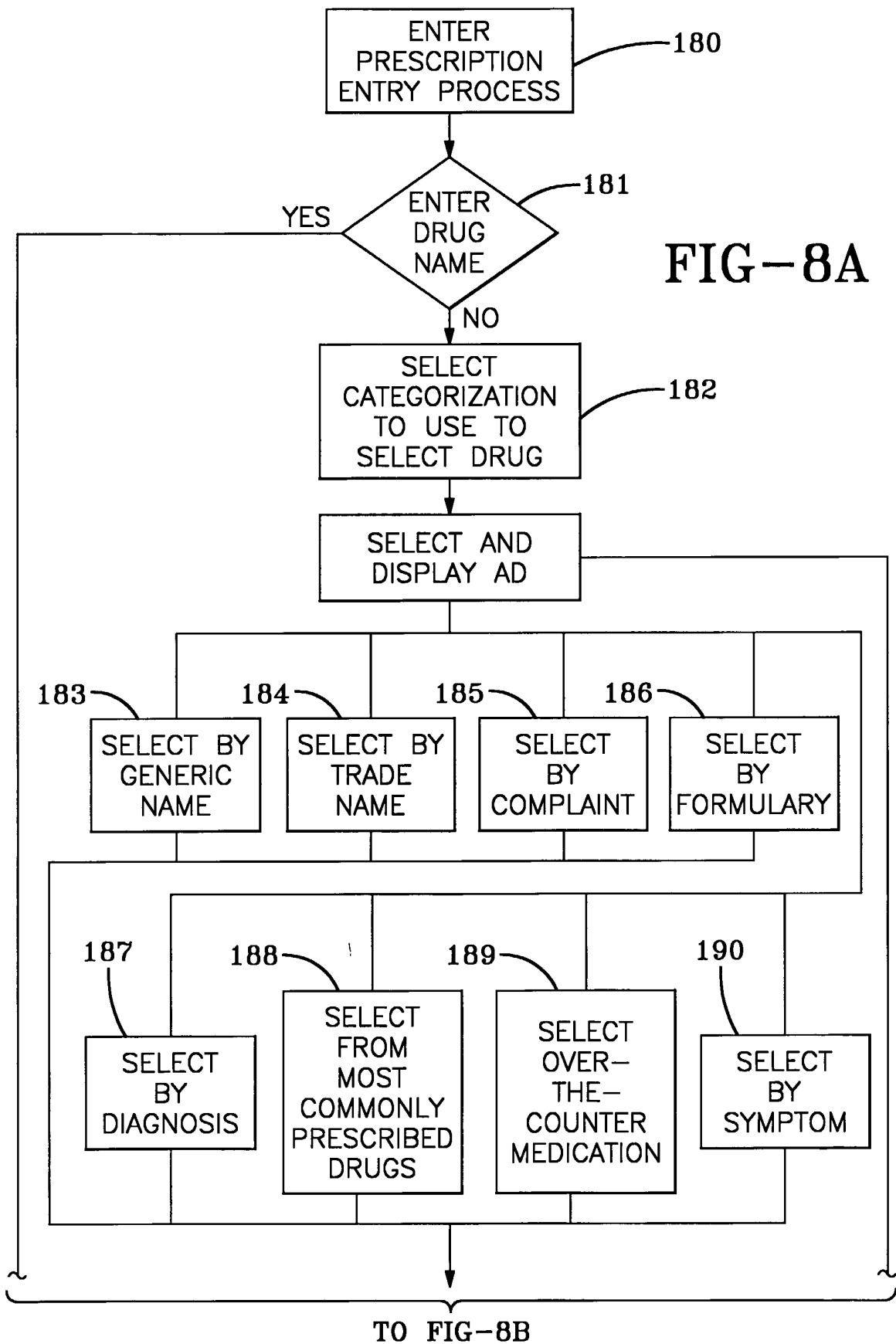

FIG-7

18/52



19/52

FROM FIG-8A

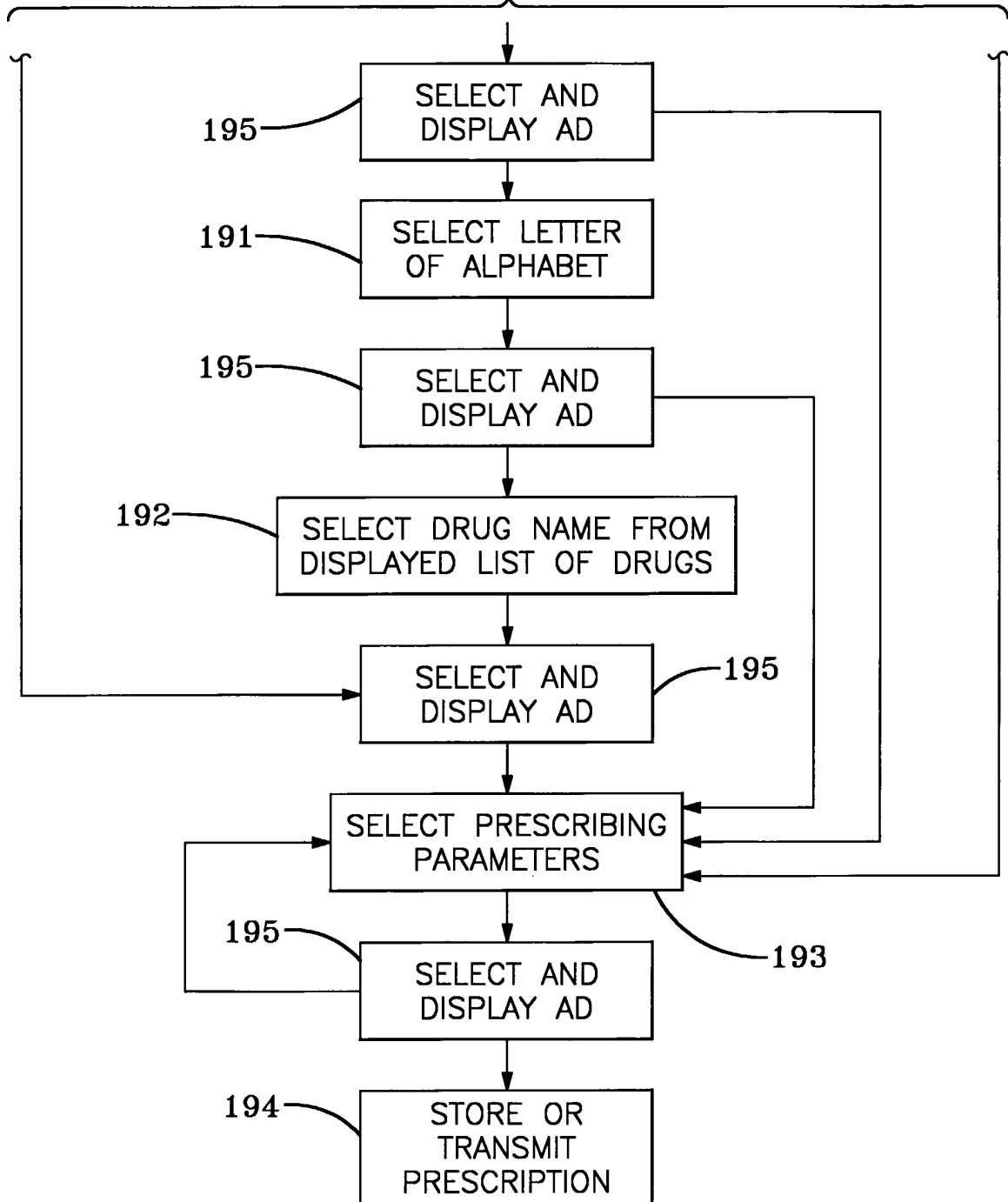

FIG-8B

20/52

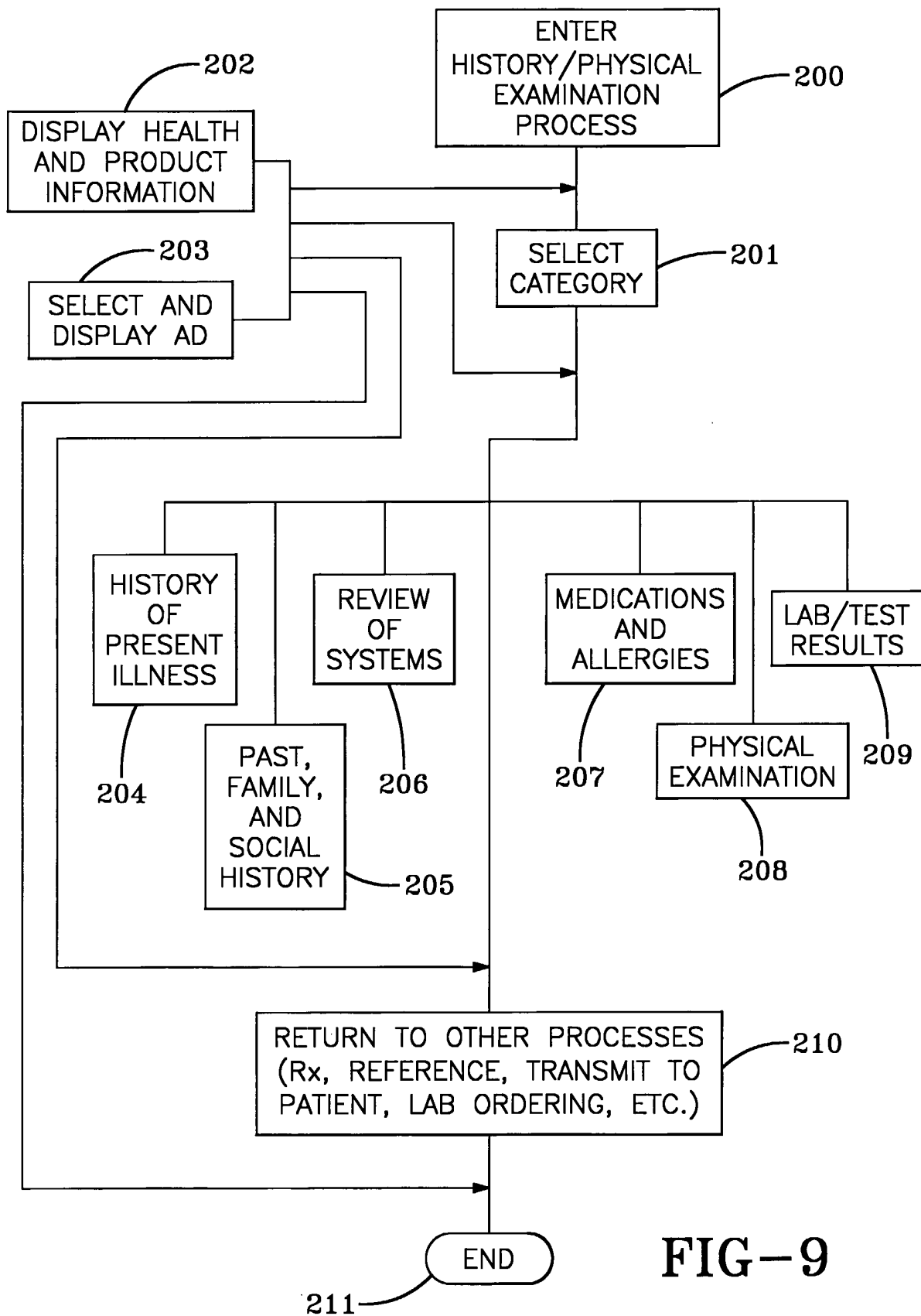

FIG-9





ADVERTISEMENT

DIAGNOSIS RESULTS

<p>CBC</p> <p>___ WNL</p> <p>___ Abnormal:</p> <p>Hgb ___</p> <p>Hct ___</p> <p>Plat ___</p> <p>WBC ___</p> <p>Bands ___</p> <p>Segs ___</p> <p>Lymphs ___</p> <p>Monos ___</p> <p>Eos ___</p>	<p>SMA</p> <p>___ WNL</p> <p>___ Abnormal:</p> <p>Na ___</p> <p>K ___</p> <p>Cl ___</p> <p>CO2 ___</p> <p>BUN ___</p> <p>Creat. ___</p> <p>Glucose ___</p> <p>Ca ___</p> <p>Other Chems: ___</p>	<p>Cardio</p> <p>Trop-I ___</p> <p>CK ___</p> <p>CKMB ___</p> <p>Coagulation ___</p> <p>PT ___</p> <p>PTT ___</p> <p>INR ___</p> <p>Abdom. Chem. ___</p> <p>Amylase ___</p> <p>Lipase ___</p> <p>Tbil ___</p> <p>SGOT ___</p> <p>SGPT ___</p>	<p>Urinalysis</p> <p>___ WNL</p> <p>___ Abnormal:</p> <p>WBC ___</p> <p>RBCs ___</p> <p>LE ___</p> <p>Nitrate ___</p> <p>Bact. ___</p> <p>Ketones ___</p>
--	--	---	---

Other Test Results: \_\_\_\_\_

\_\_\_\_\_

\_\_\_\_\_

\_\_\_\_\_

\_\_\_\_\_

\_\_\_\_\_

\_\_\_\_\_

\_\_\_\_\_

\_\_\_\_\_

\_\_\_\_\_

\_\_\_\_\_

\_\_\_\_\_

EKG

\_\_\_ EKG Normal

\_\_\_ NSR

\_\_\_ Normal Axis

\_\_\_ Normal Intervals

\_\_\_ Normal QRS

\_\_\_ Normal ST/T

\_\_\_ Discussed w/ Cardiologist

Repeat EKG: Time: \_\_\_\_\_

\_\_\_ Unchanged \_\_\_ Changed:

Abnormalities:

\_\_\_ Inverted T Wave

\_\_\_ Long PR Interval

\_\_\_ ST Elevation

\_\_\_ ST Depression

\_\_\_ Wide QRS Int.

\_\_\_ Other: \_\_\_\_\_

C-Spine XRAY

\_\_\_ Normal/Nad

\_\_\_ Epiglottis WNL

\_\_\_ Soft Tissues WNL

\_\_\_ Discussed with Radiologist

Other/Notes: \_\_\_\_\_

\_\_\_ Fracture

\_\_\_ Enlgd Epiglottis

\_\_\_ Lesions/Nodes

FIG-11

23/52

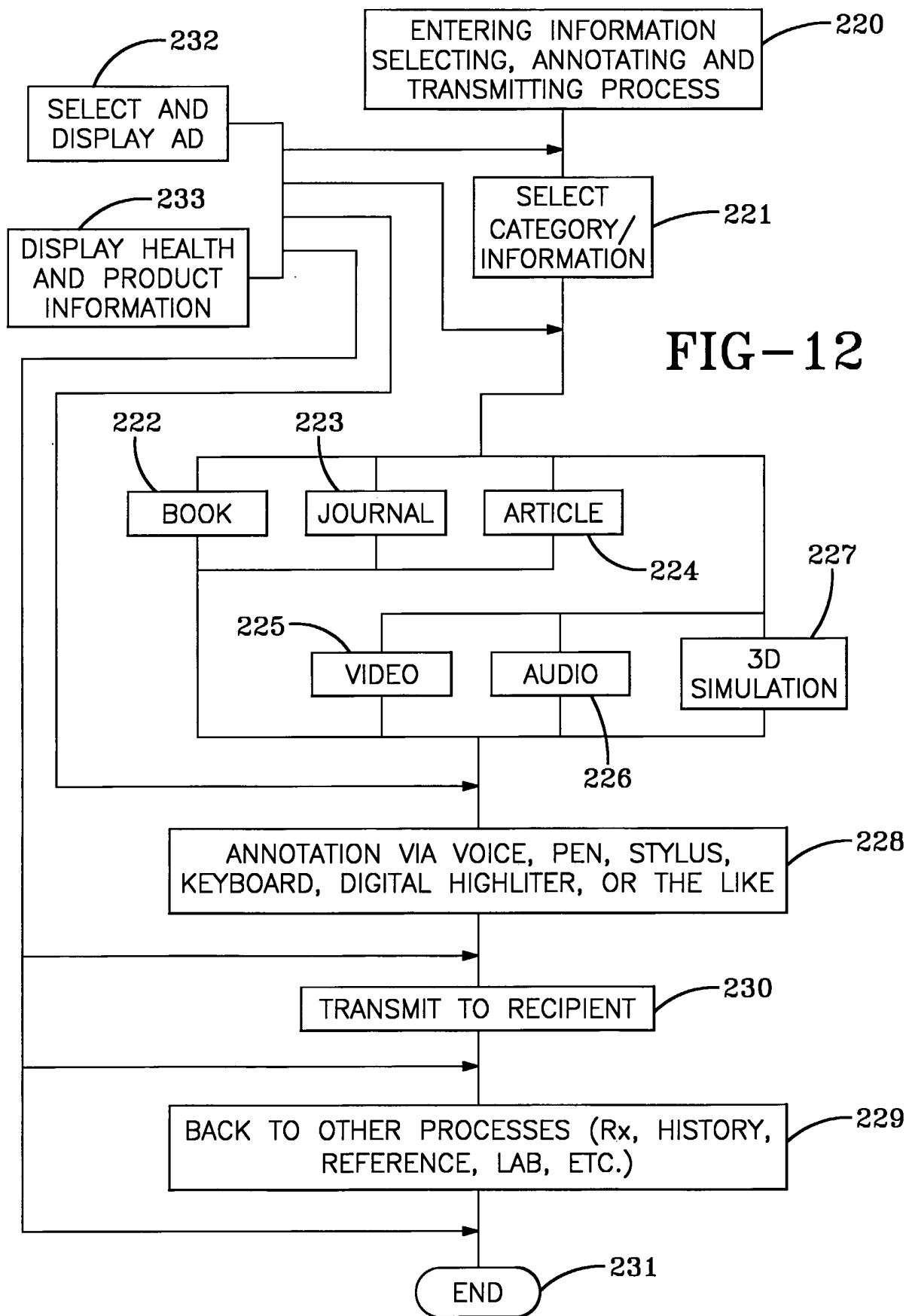
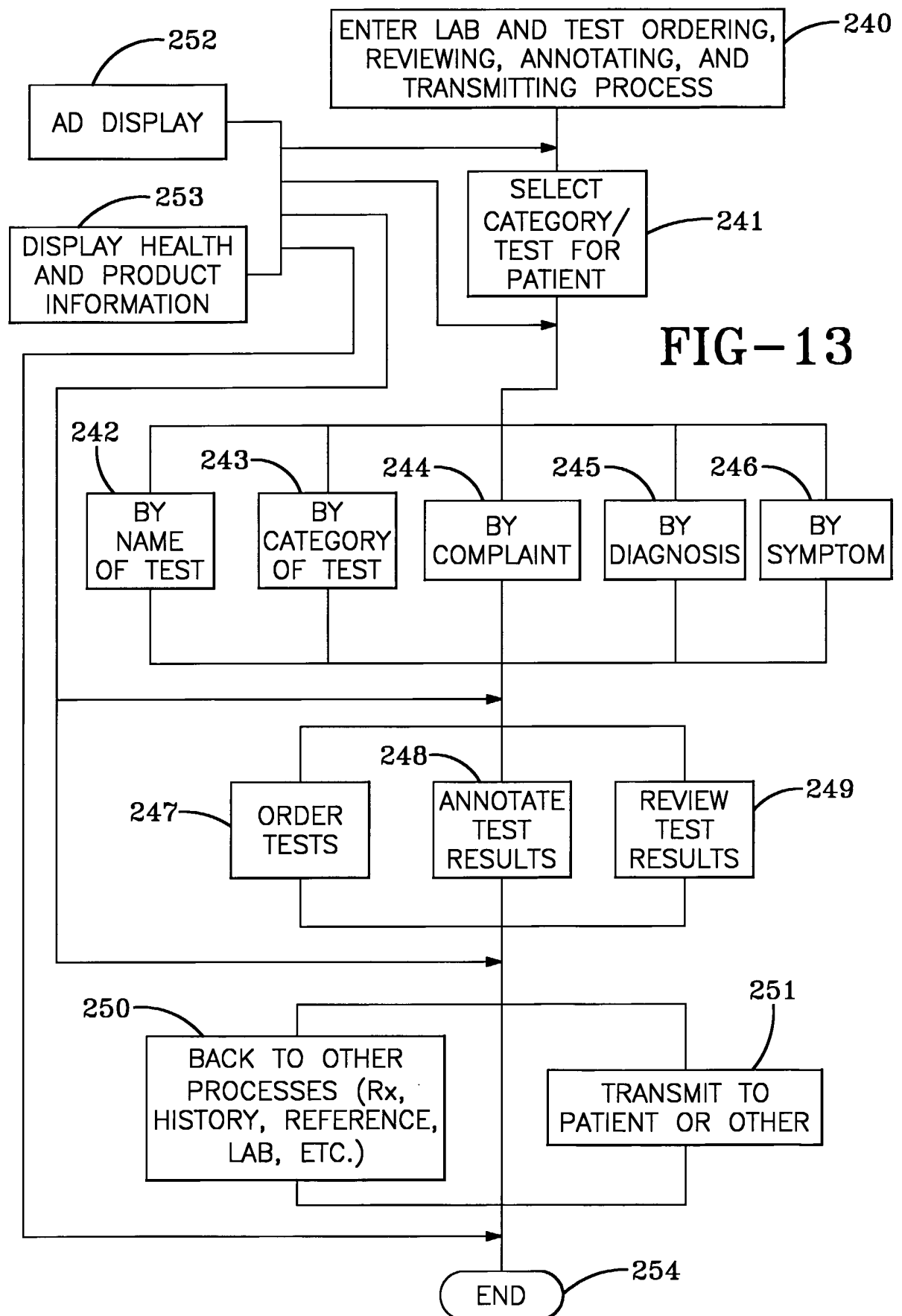

FIG-12

24/52



25/52

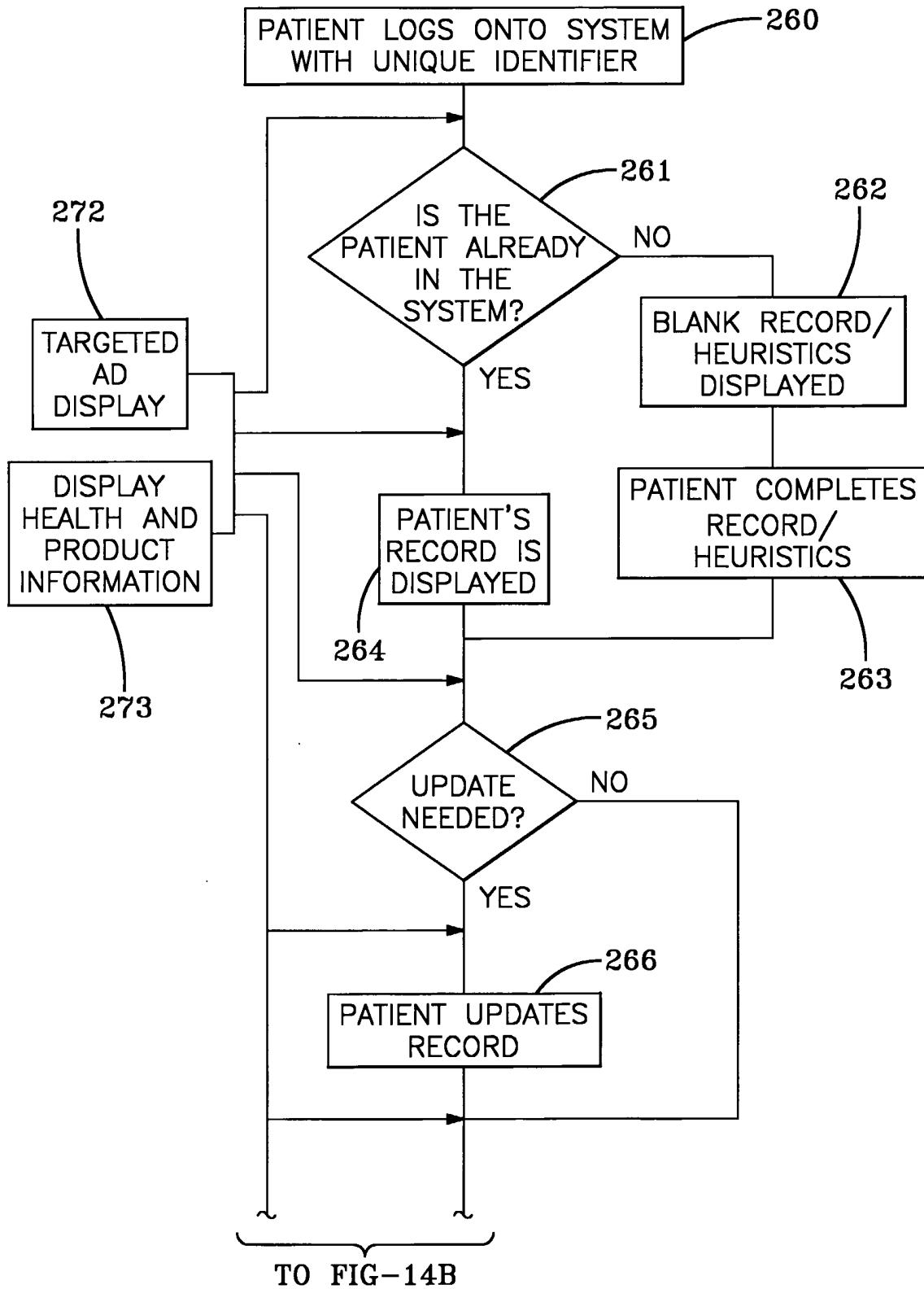

FIG-14A

26/52

FROM FIG-14A

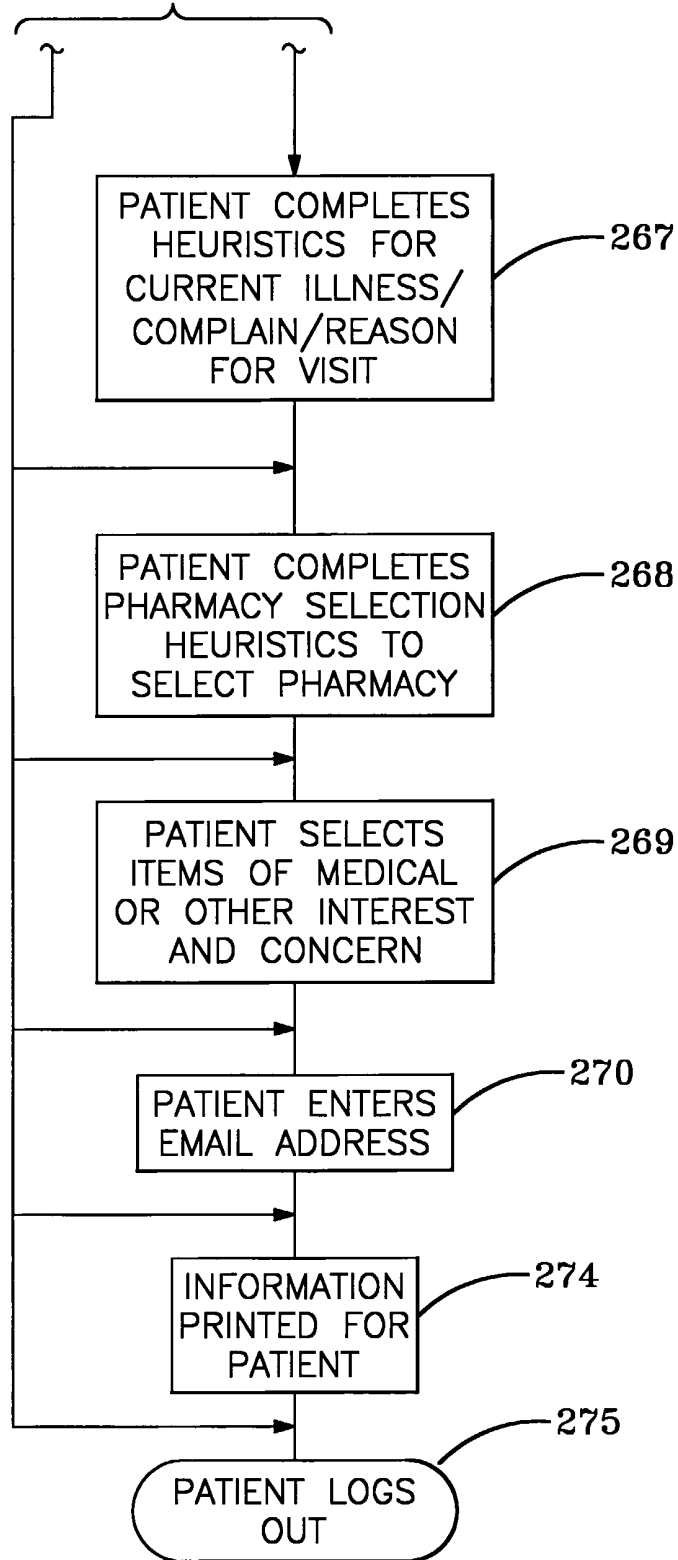

FIG-14B

27/52

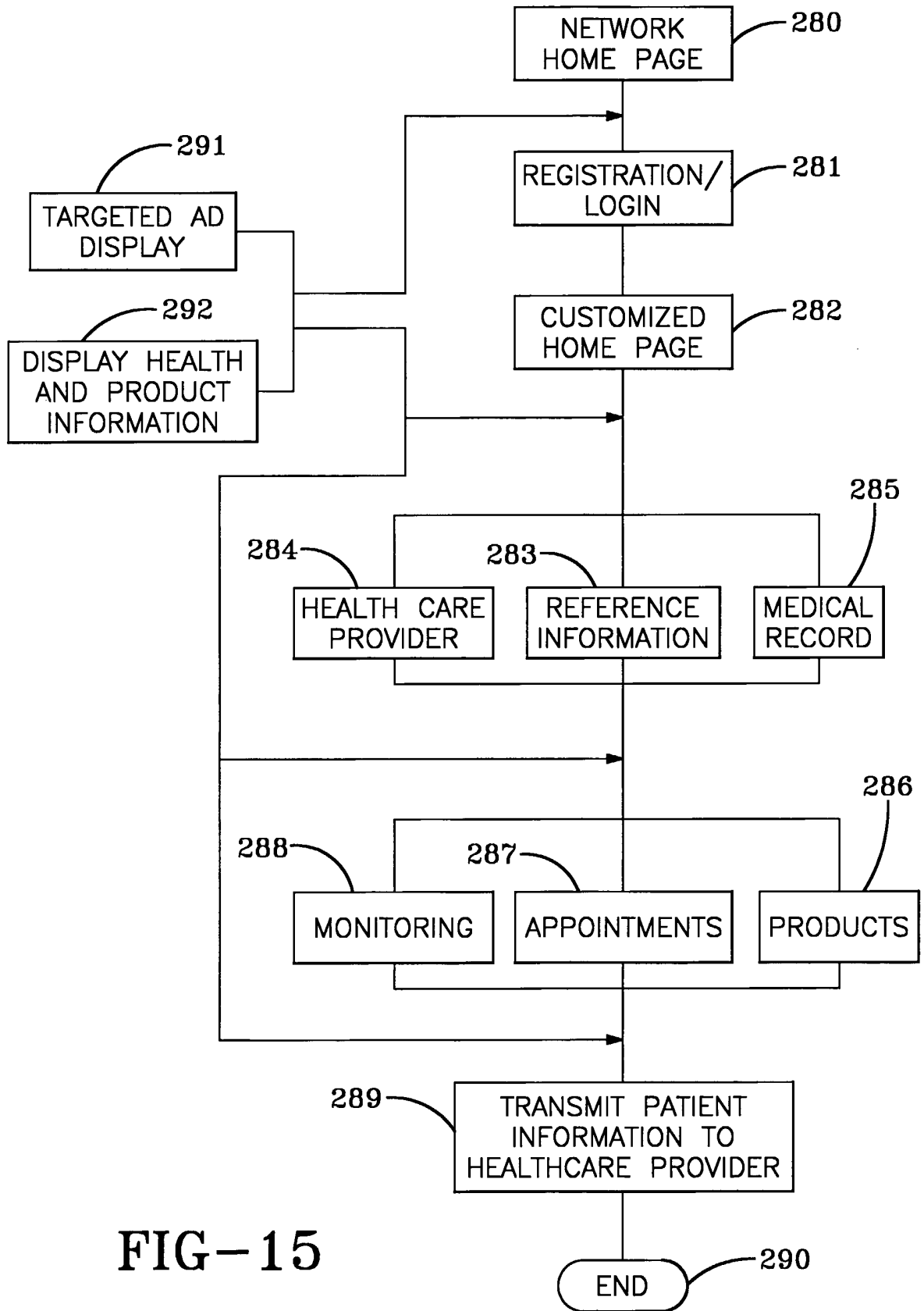

FIG-15

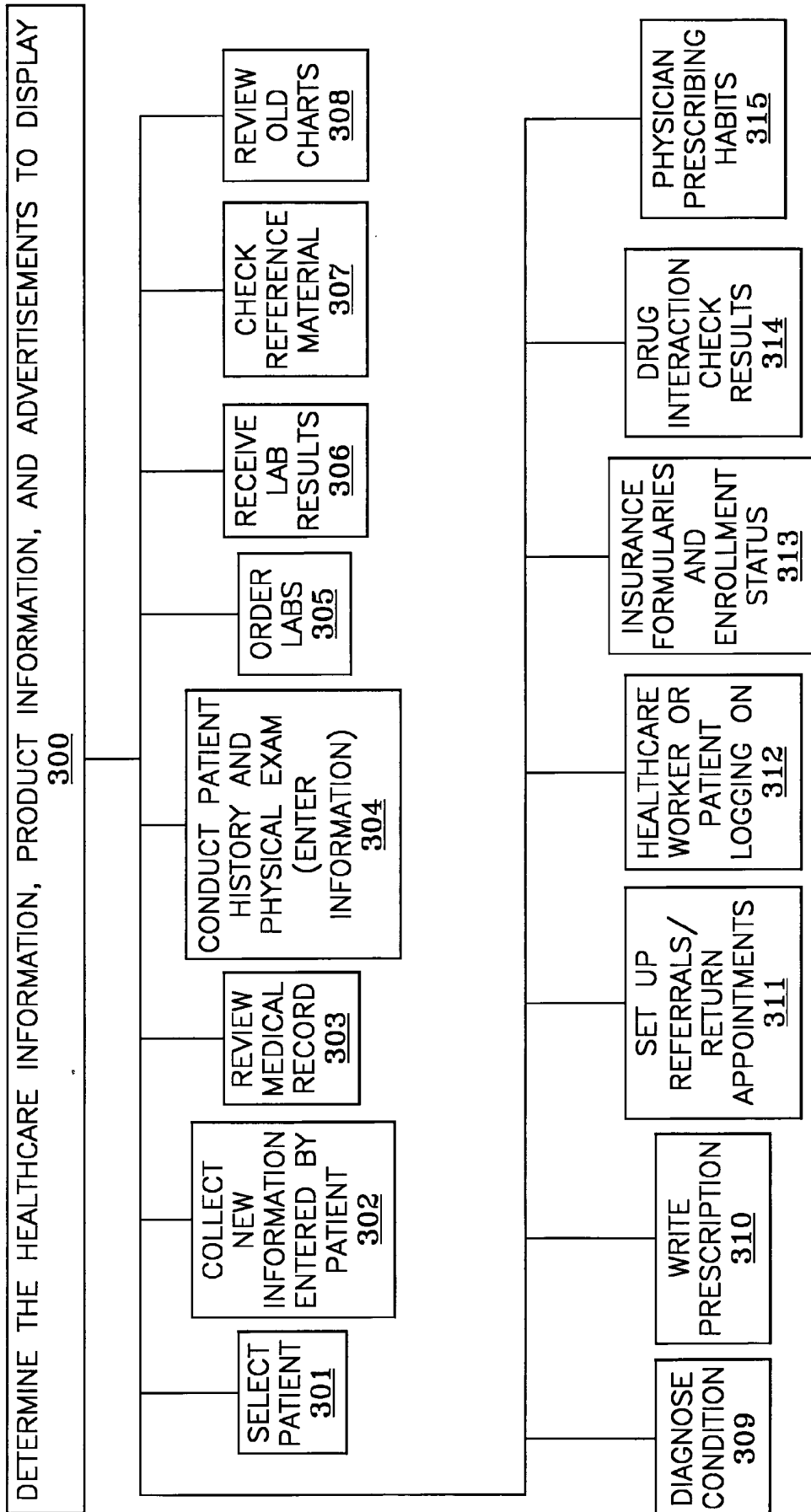
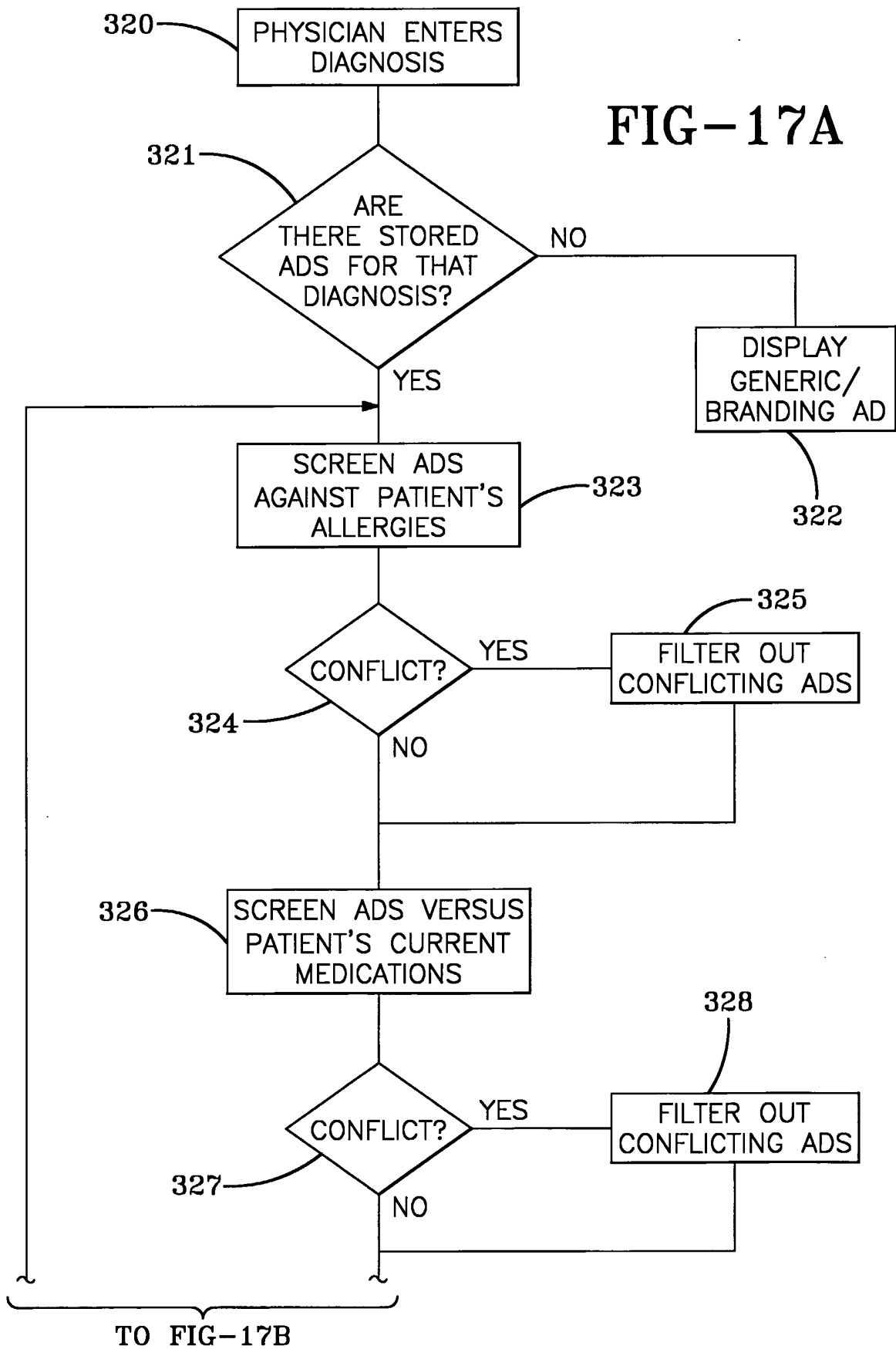

FIG-16

29/52

FIG-17A





30/52

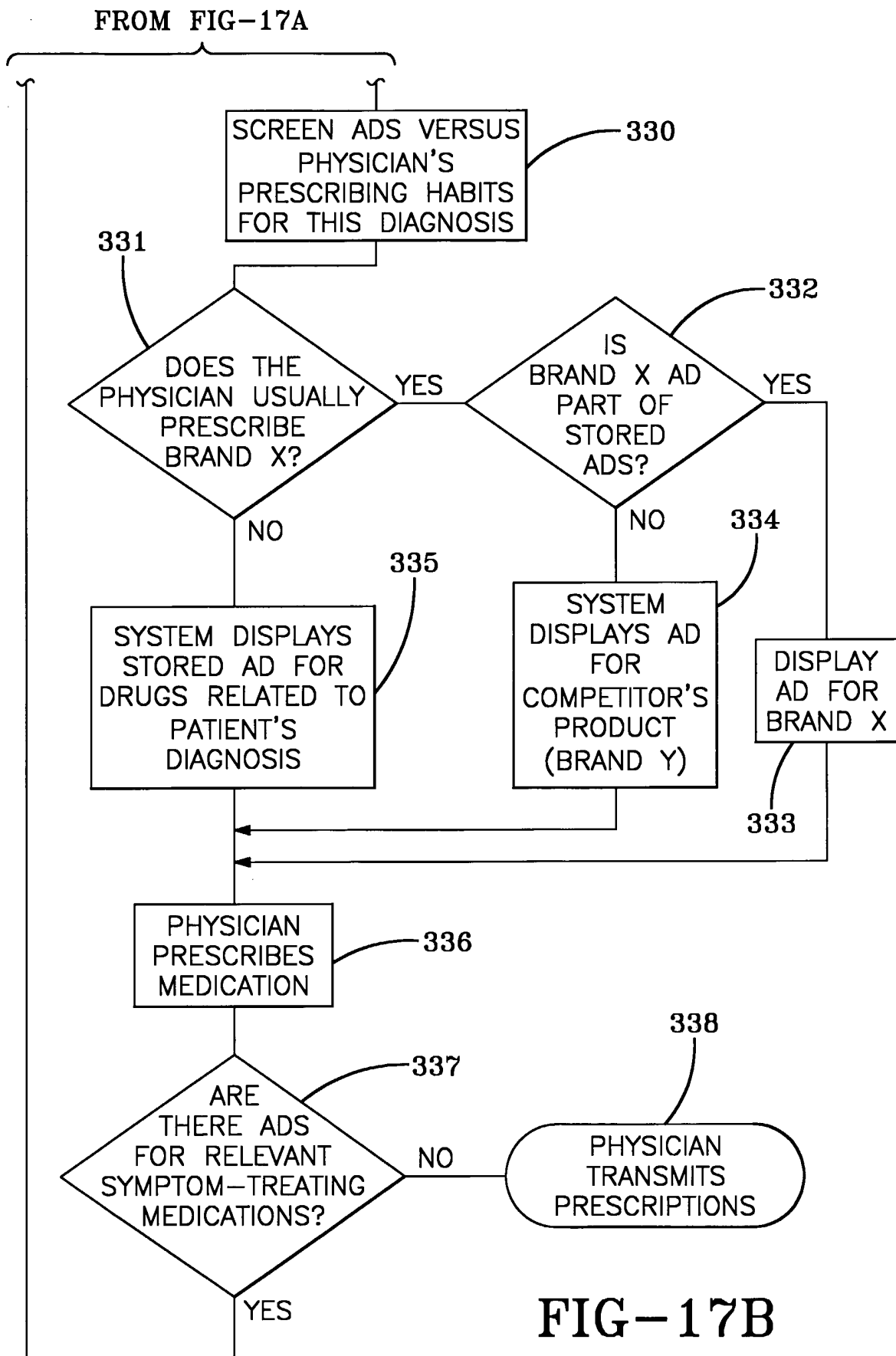

FIG-17B

31/52

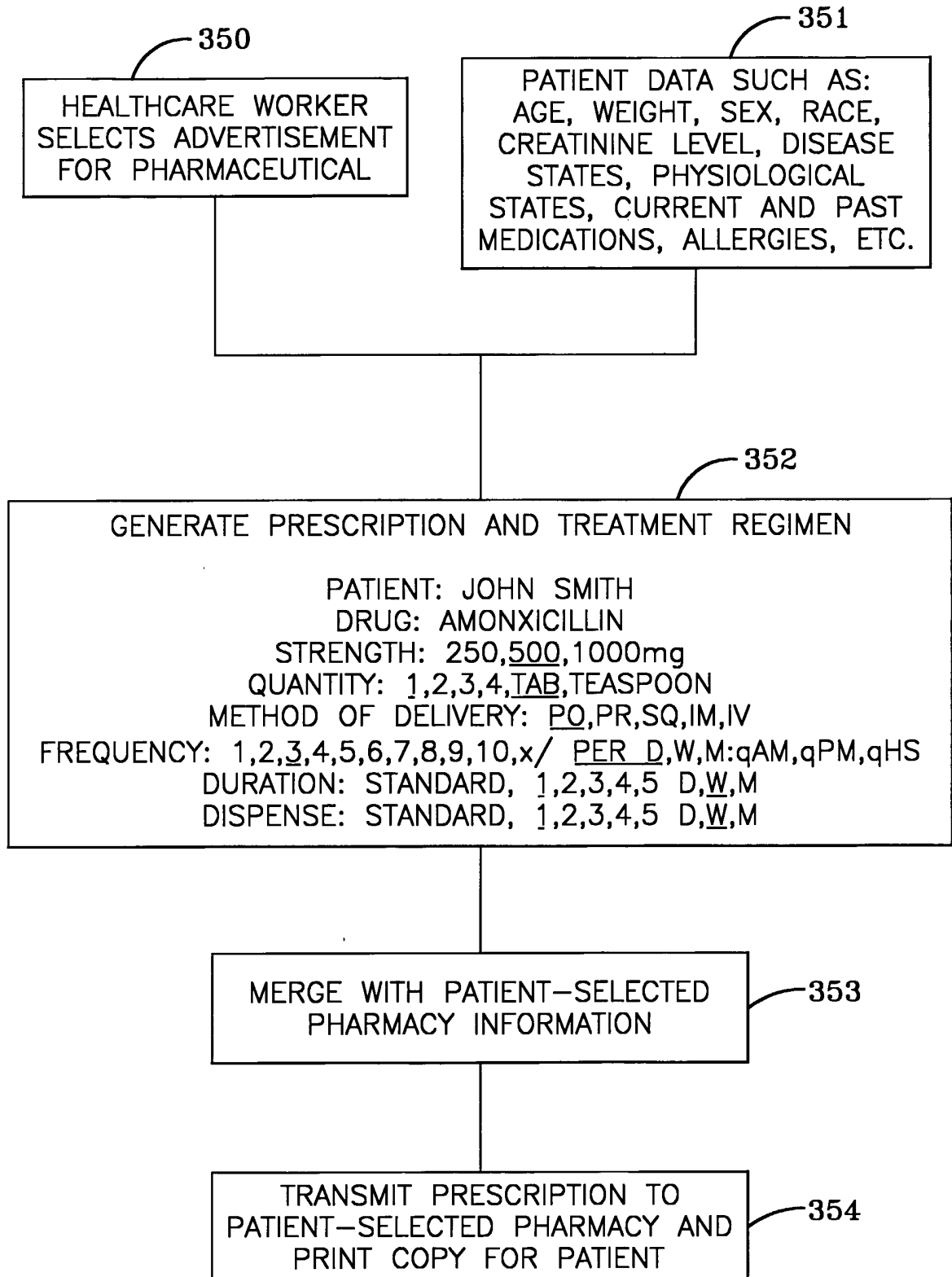

FIG-18A

32/52

TOUCH ON THE STRENGTH, QUANTITY, METHOD OF DELIVERY,  
FREQUENCY, DURATION, AND DISPENSING LEVEL TO SELECT.

PATIENT: JOHN SMITH  
DRUG: AMONXICILLIN  
STRENGTH: 250,500,1000mg  
QUANTITY: 1,2,3,4,TAB,TEASPOON  
METHOD OF DELIVERY: PO,PR,SQ,IM,IV  
FREQUENCY: 1,2,3,4,5,6,7,8,9,10,x/ PER D,W,M:qAM,qPM,qHS  
DURATION: STANDARD, 1,2,3,4,5 D,W,M  
DISPENSE: STANDARD, 1,2,3,4,5 D,W,M

FIG-18B

33/52

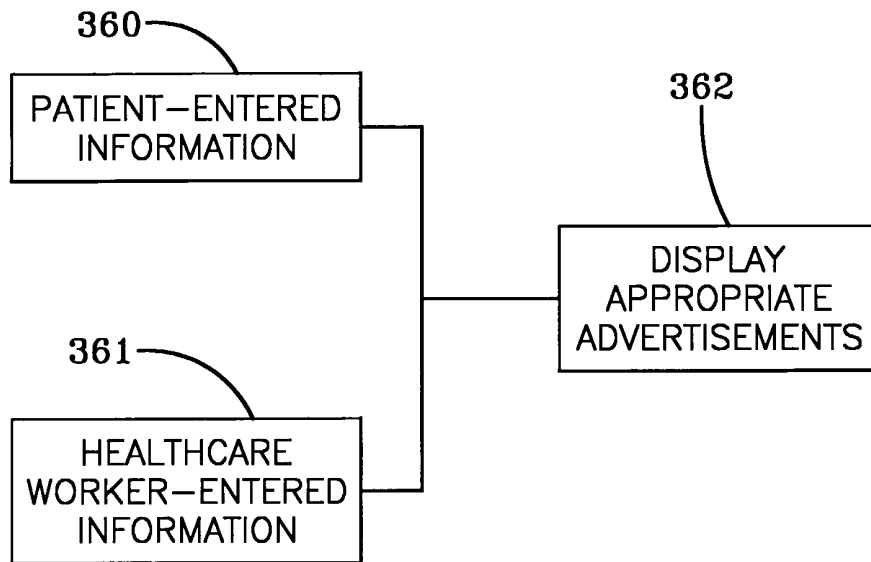

FIG-19

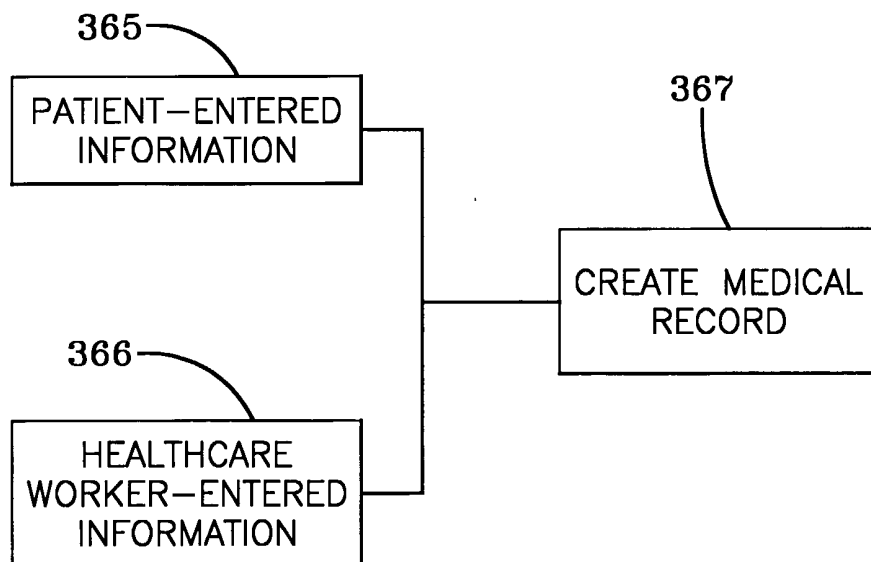

FIG-20

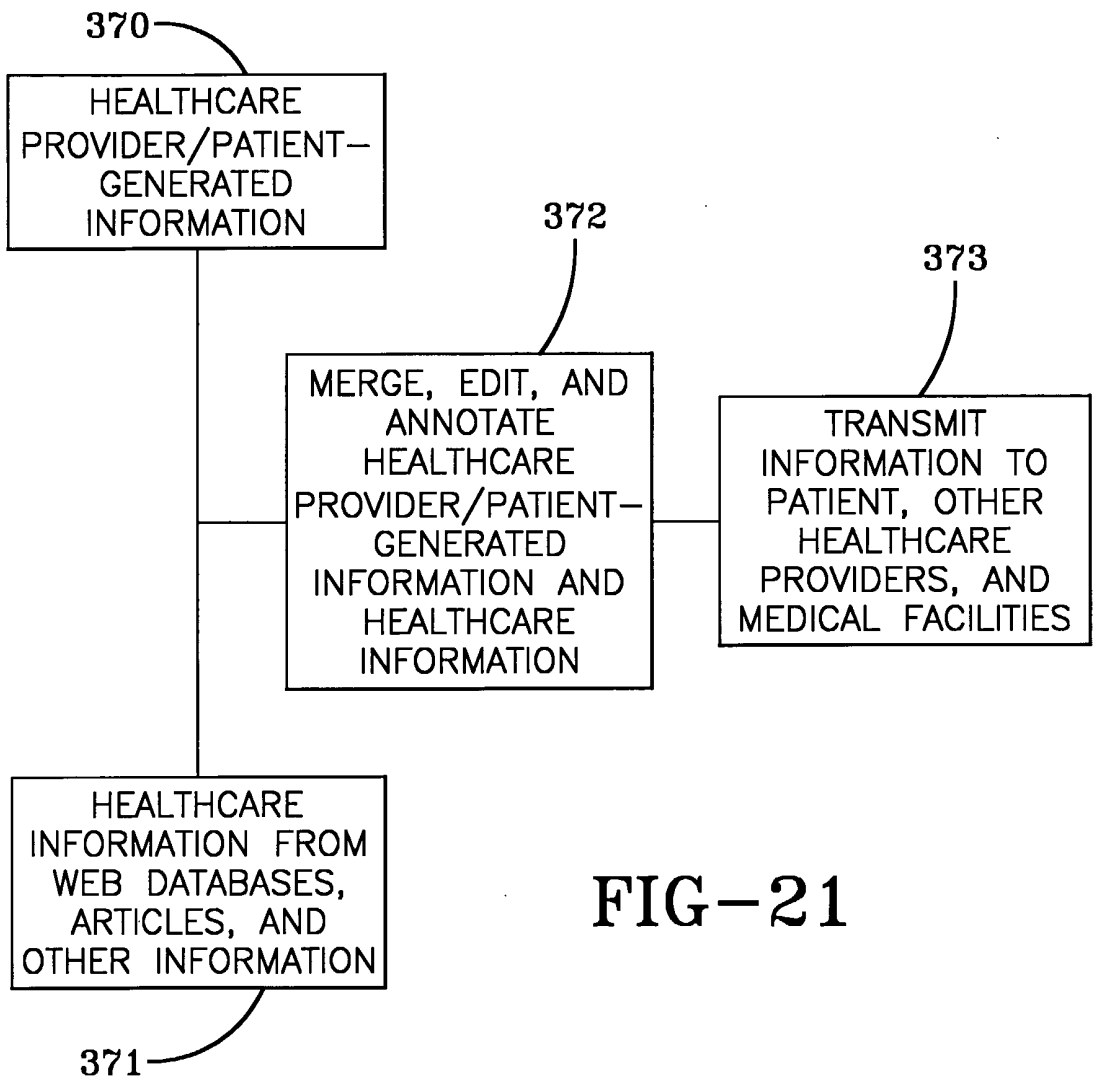

FIG-21

35/52

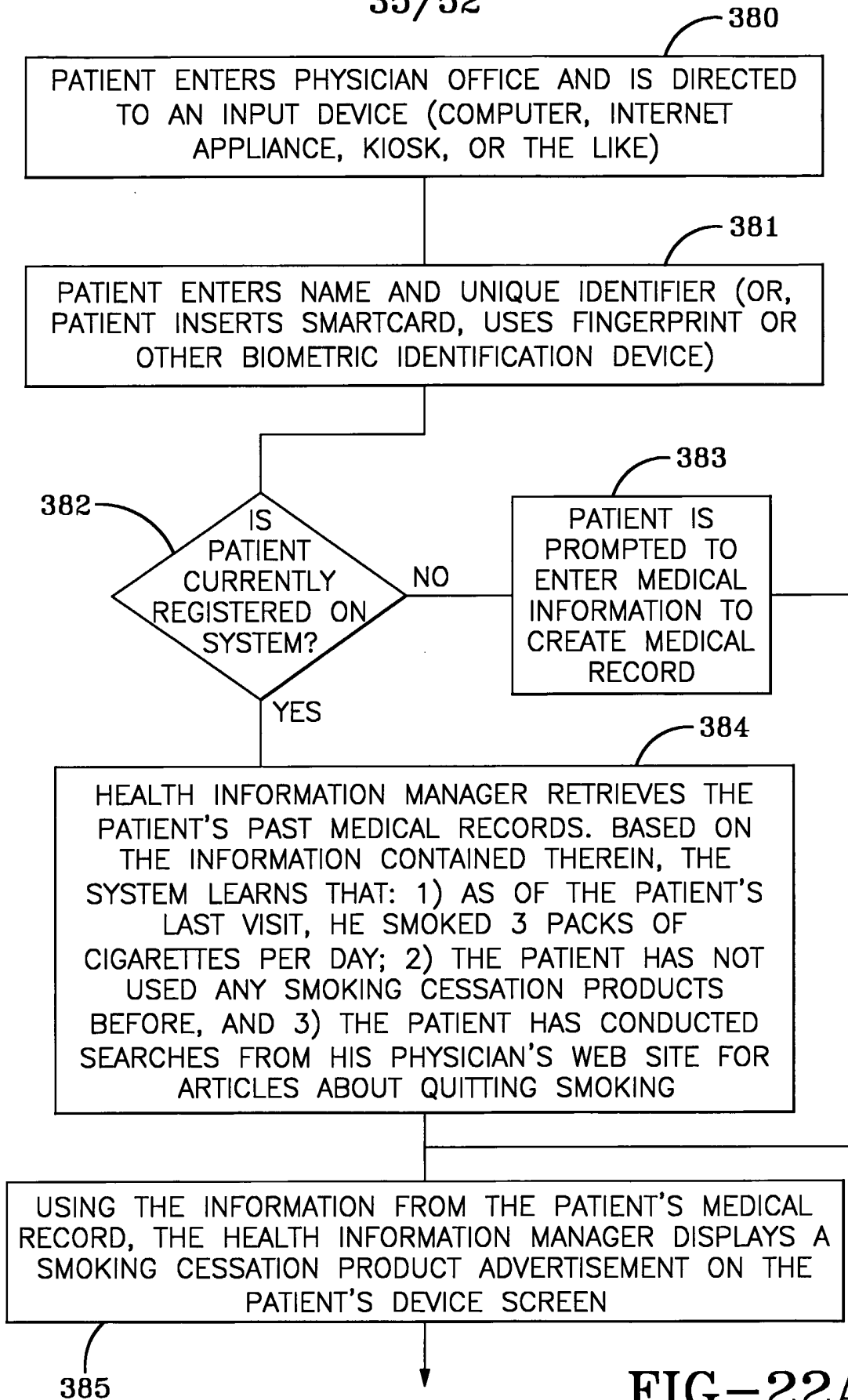

FIG-22A

36/52

FROM FIG-22A

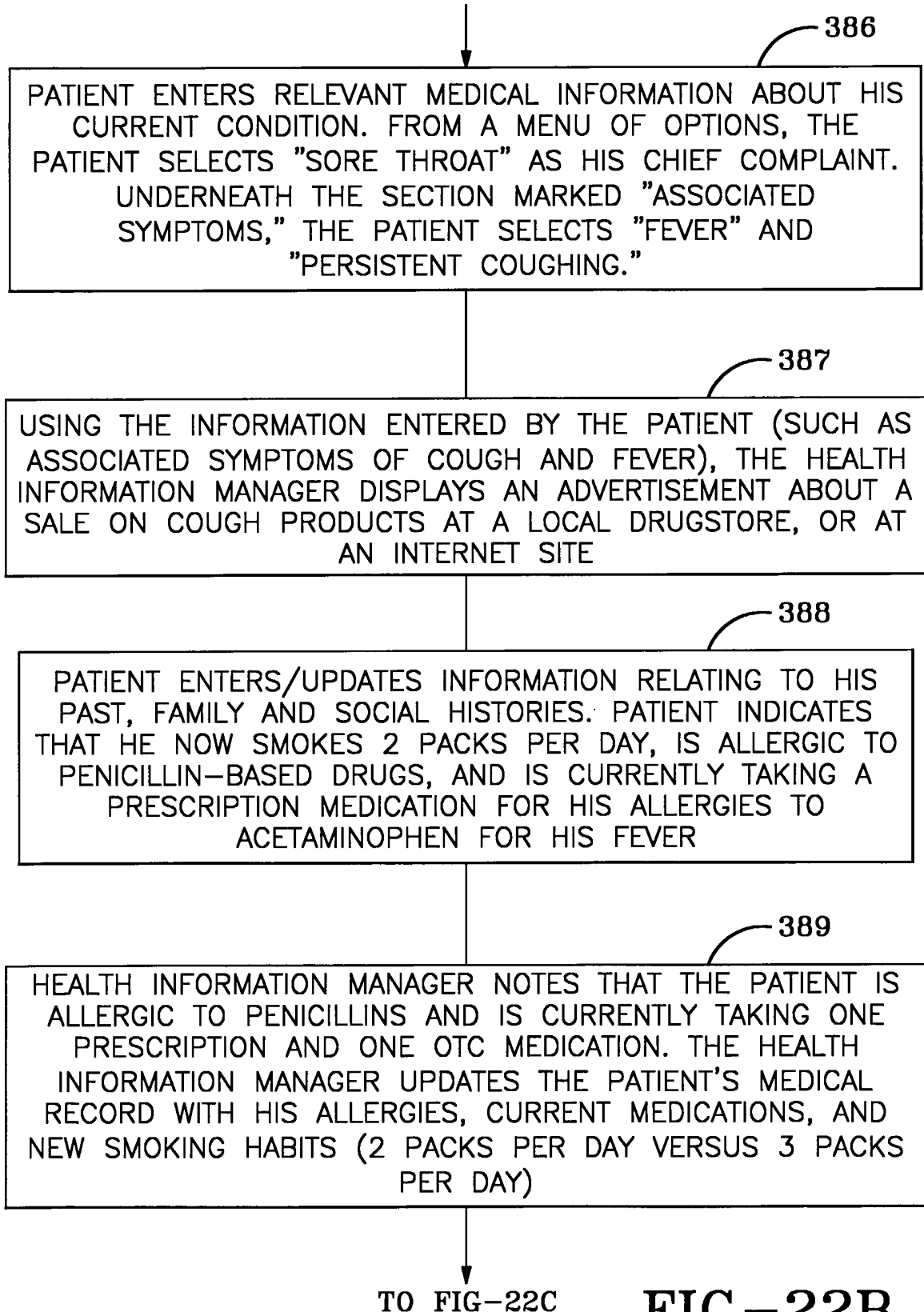

FIG-22B

FROM FIG-22B

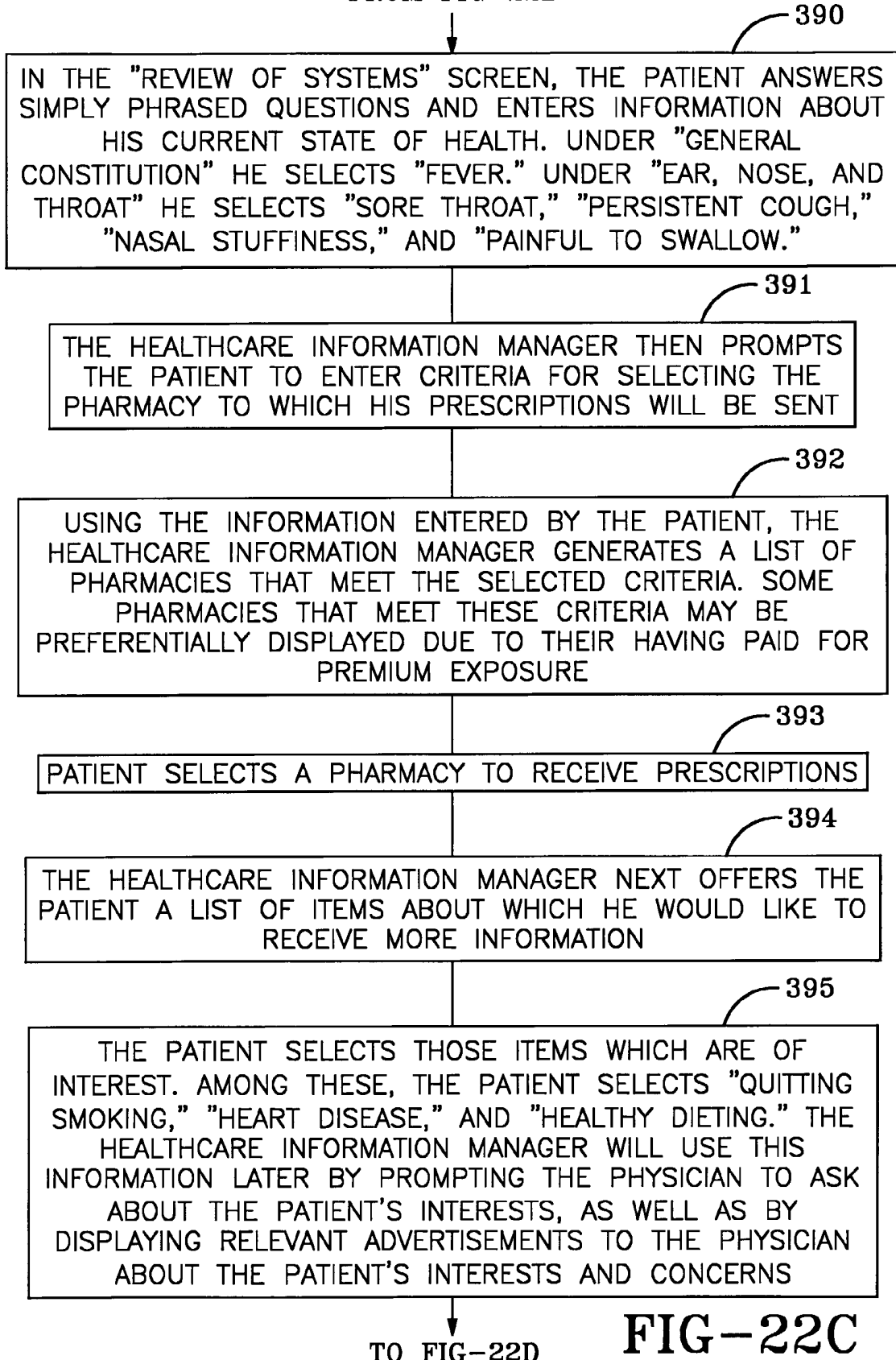
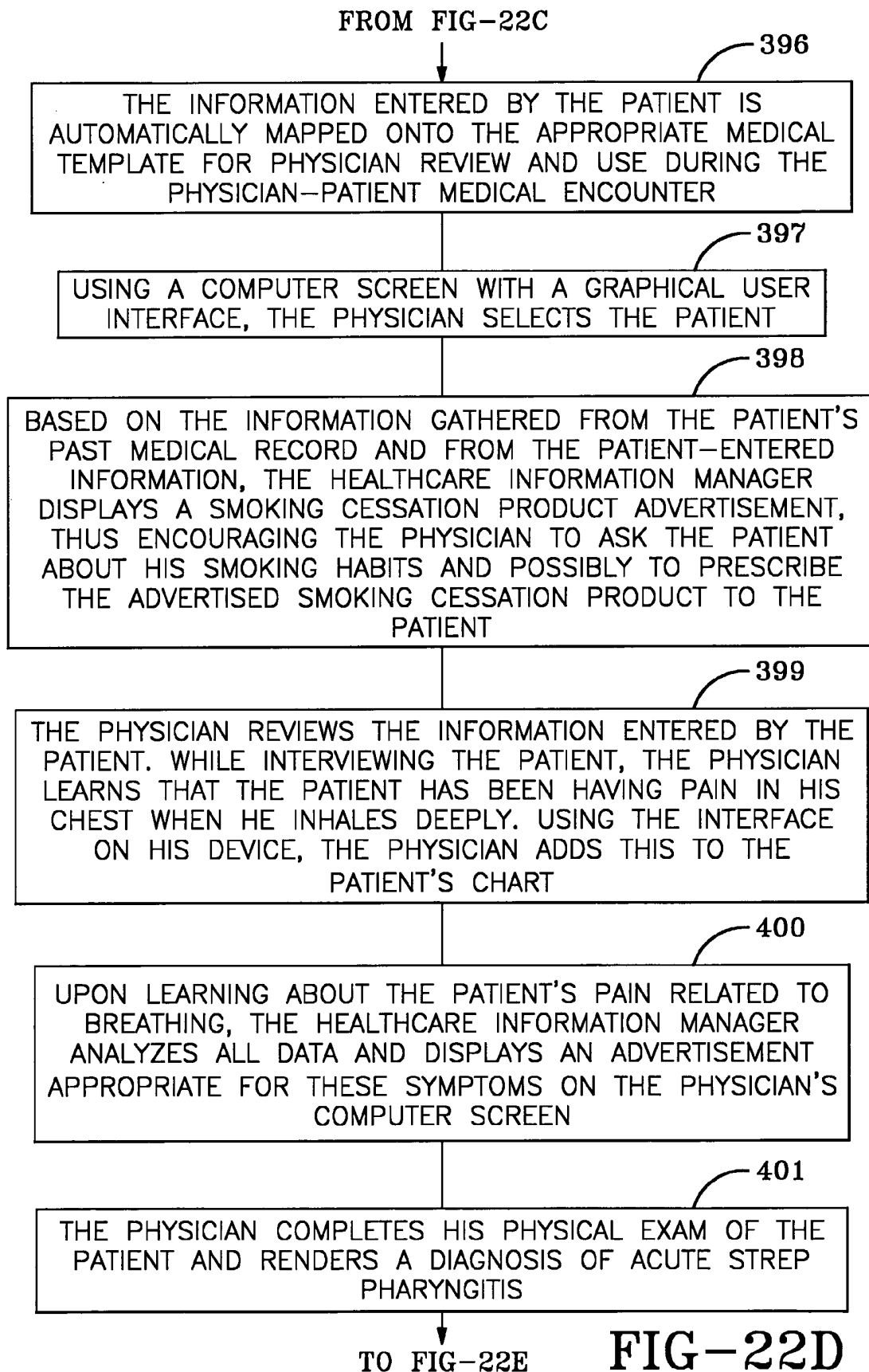

FIG-22C



38/52



39/52

FROM FIG-22D

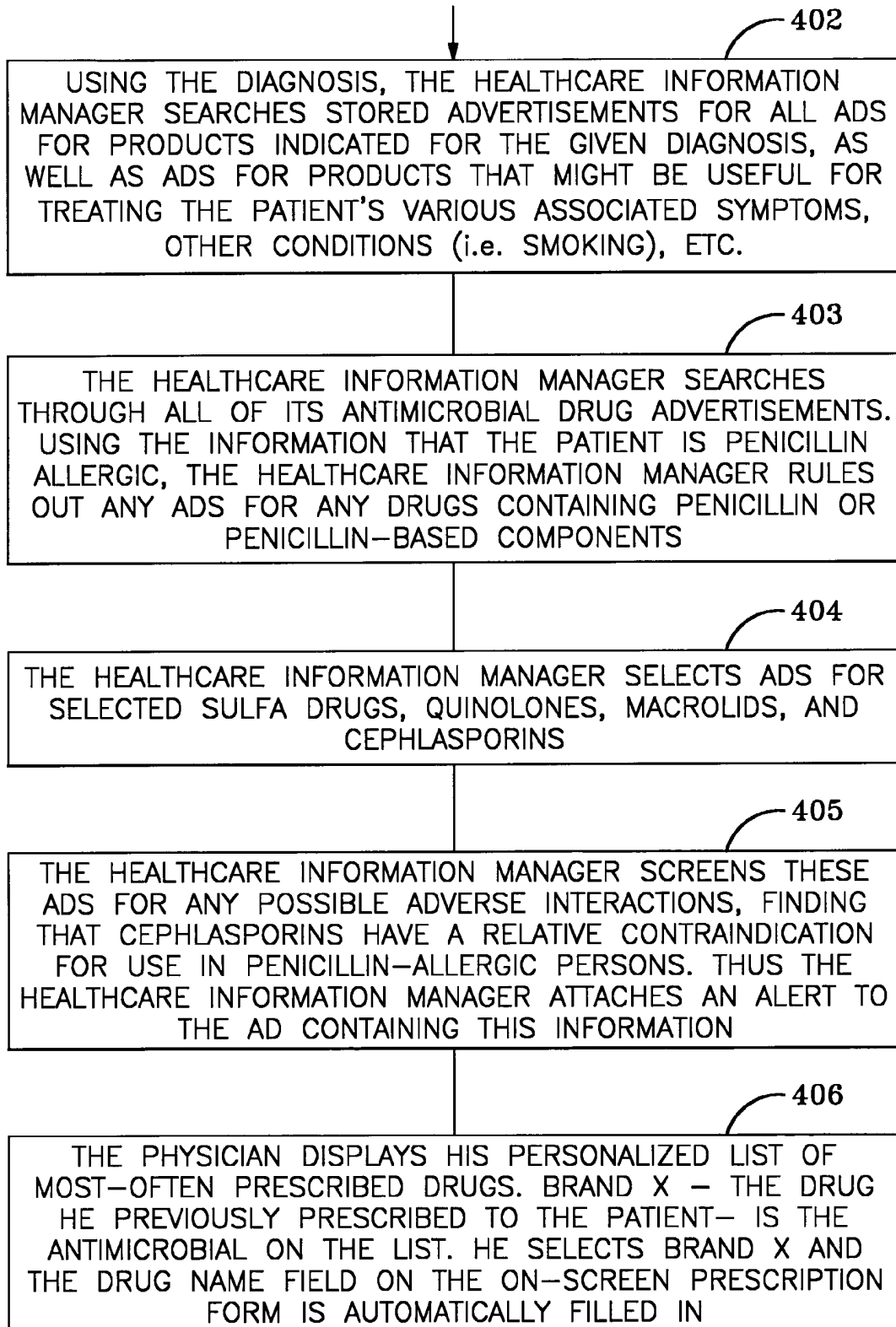

TO FIG-22F

FIG-22E

40/52

FROM FIG-22E

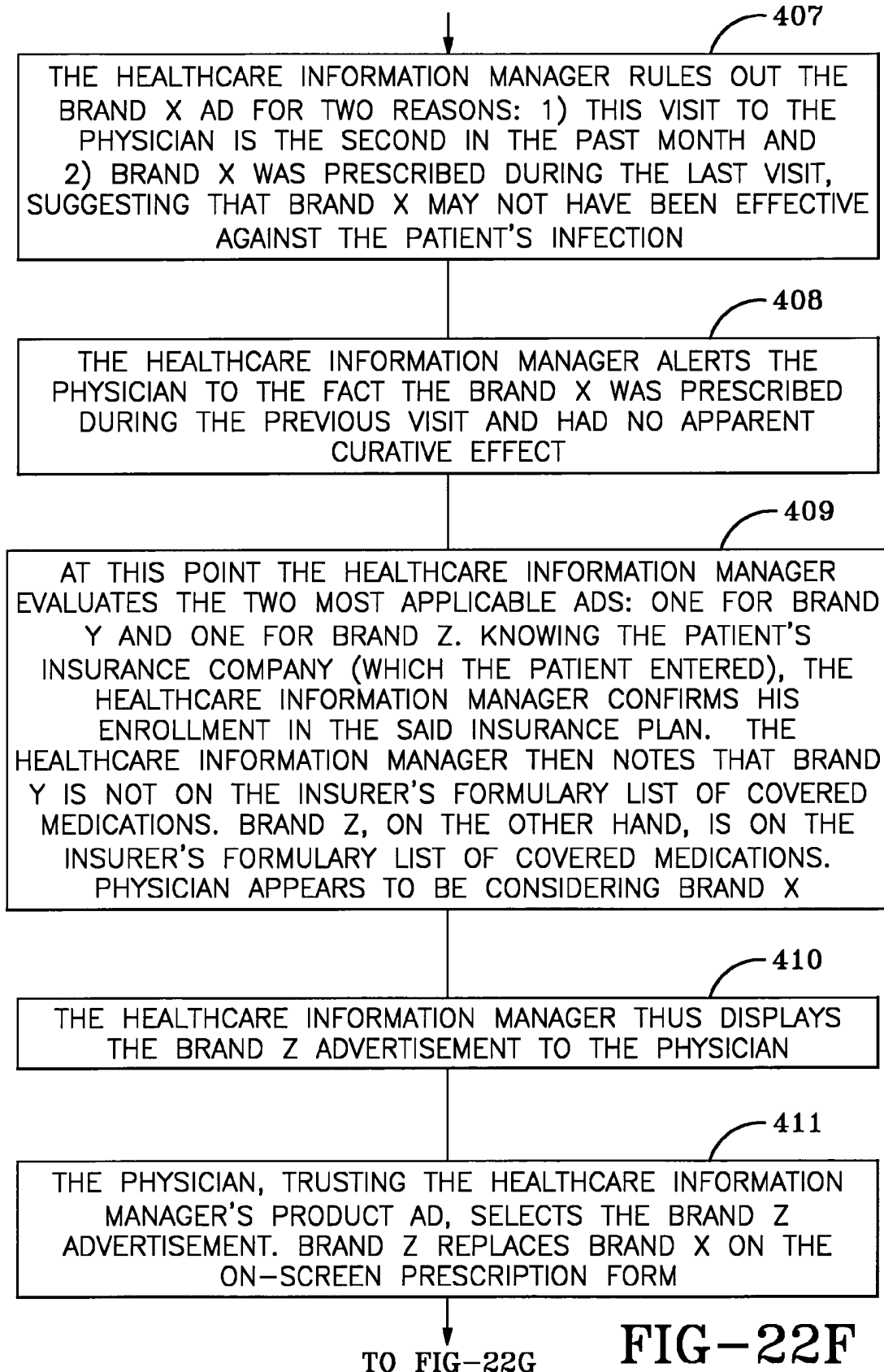
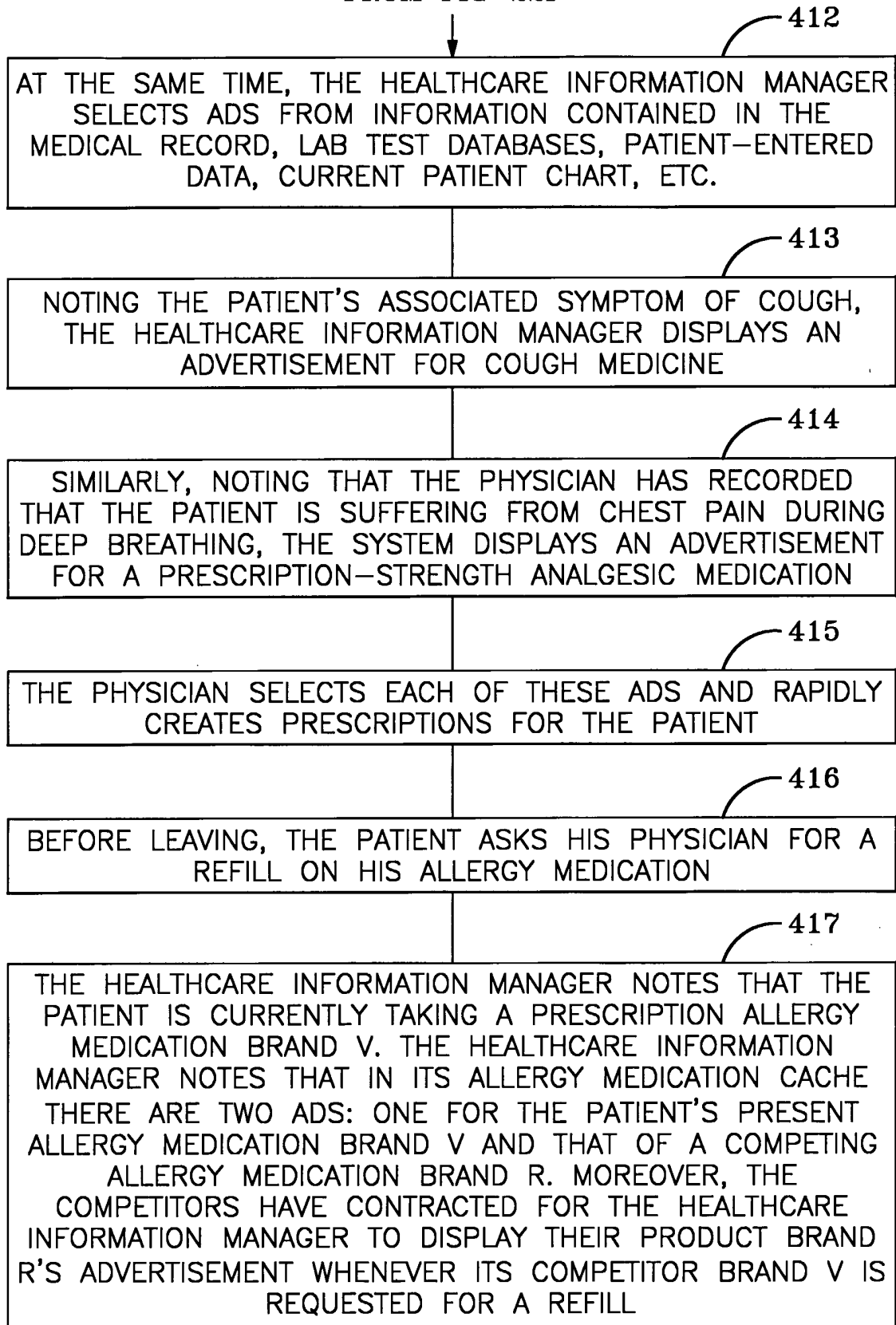

FIG-22F

41/52

FROM FIG-22F



TO FIG-22H

FIG-22G

42/52

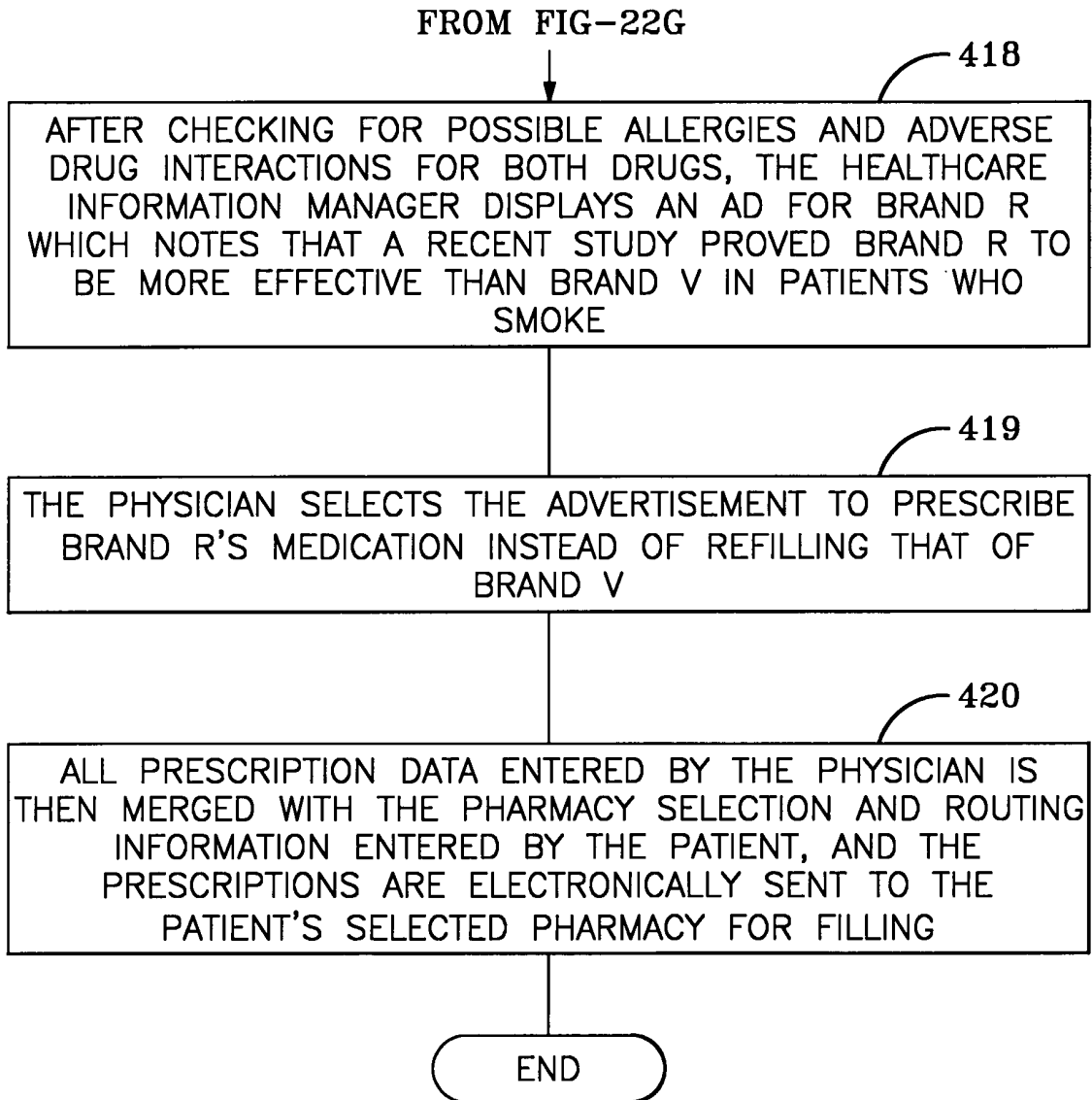

FIG-22H

PLEASE SELECT PHARMACY OPTIONS

ADVERTISEMENT

525

Here you search for a participating pharmacy that meets your particular needs. Simply select from any or all of the options below. The next page will show a list of pharmacies that match your requested options. The pharmacy you then choose will receive your prescription information electronically, making it easier for you to get the medicine your doctor may determine you need.

To select a particular item, touch the down arrow on the right and select your choice from the displayed list.

Then touch the CONTINUE button on the screen.

If you make a mistake and wish to clear your selections, touch RESET.

PHARMACY:	SELECT A PHARMACY	↓	
AREA OF TOWN:	SELECT AREA OF TOWN	↓	
STORE HOURS:	SELECT STORE HOURS	↓	<u>526</u>
DELIVERY OPTIONS:	SELECT DELIVERY OPTIONS	↓	
PRESCRIPTION INSURANCE:	SELECT PRESCRIPTION INSURANCE	↓	

CONTINUE

RESET

FIG-23

PLEASE SELECT A PHARMACY

ADVERTISEMENT

527

528

The following pharmacies meet the requirements you requested:

Select	Pharmacy	Area of Town	Address	Store Hours	Delivery Options	Rx Insurance
<input type="radio"/>	Store A	Central	426 Main	24 hrs	None	Co-Pay
<input type="radio"/>	Store B	Central	112 4th	24 hrs	None	Co-Pay
<input type="radio"/>	Store C	Central	9815 Park	24 hrs	None	Co-Pay

To select a particular pharmacy, touch the circular button to the left of the pharmacy's name. Then touch the CONTINUE button on the screen.

If you make a mistake and wish to clear your selections, touch RESET.

If you wish to change your options and search again, touch the BACK button.

CONTINUE

RESET

BACK

FIG-24

YOUR PHARMACY OF CHOICE

ADVERTISEMENT

529

You have chosen the following pharmacy to fill any prescriptions given to you today by your doctor.

To confirm that this is where you want your prescriptions sent, touch CONFIRM.  
If you wish to change your options and search again, touch the BACK button.

Store A  
426 Main  
Austin, TX  
(512) 555-5875  
Open 24 Hours

530

CONFIRM

BACK

FIG-25



531

John Doe, Welcome from Dr. Smith

Update your Blood Pressure  
 Make an Appointment

New Report about Smoking and Heart Attacks!

CLICK HERE

532

TARGETED ADVERTISEMENT

TODAY'S CARDIOLOGY NEWS:

New Kind of Heart Surgery

The Best Way to Walk

New Study on Heart-Healthy Foods

ACADEMIC ARTICLES

Outpatient Infusions Increase Positive Outcomes for CABG

New Role of Lipids in CHF

Books on the Heart

Living Well with Hypertension

Running for Life: My Bout with MI

How Far We've Come: A Study of Cardiac Theory from 1500-2000

Women at Risk: Women and Carotid Dissection

TARGETED ADVERTISEMENT

TARGETED ADVERTISEMENT

FIG-26

Mr. Doe. please enter your blood pressure and click the GRAPH THIS ENTRY button: 533

534

Diastolic

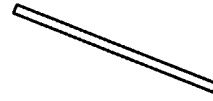

Systolic

Graph This Entry

535

FIG-27

536

537

NOVEMBER 2000  
JOHN DOE'S BLOOD PRESSURE RECORD

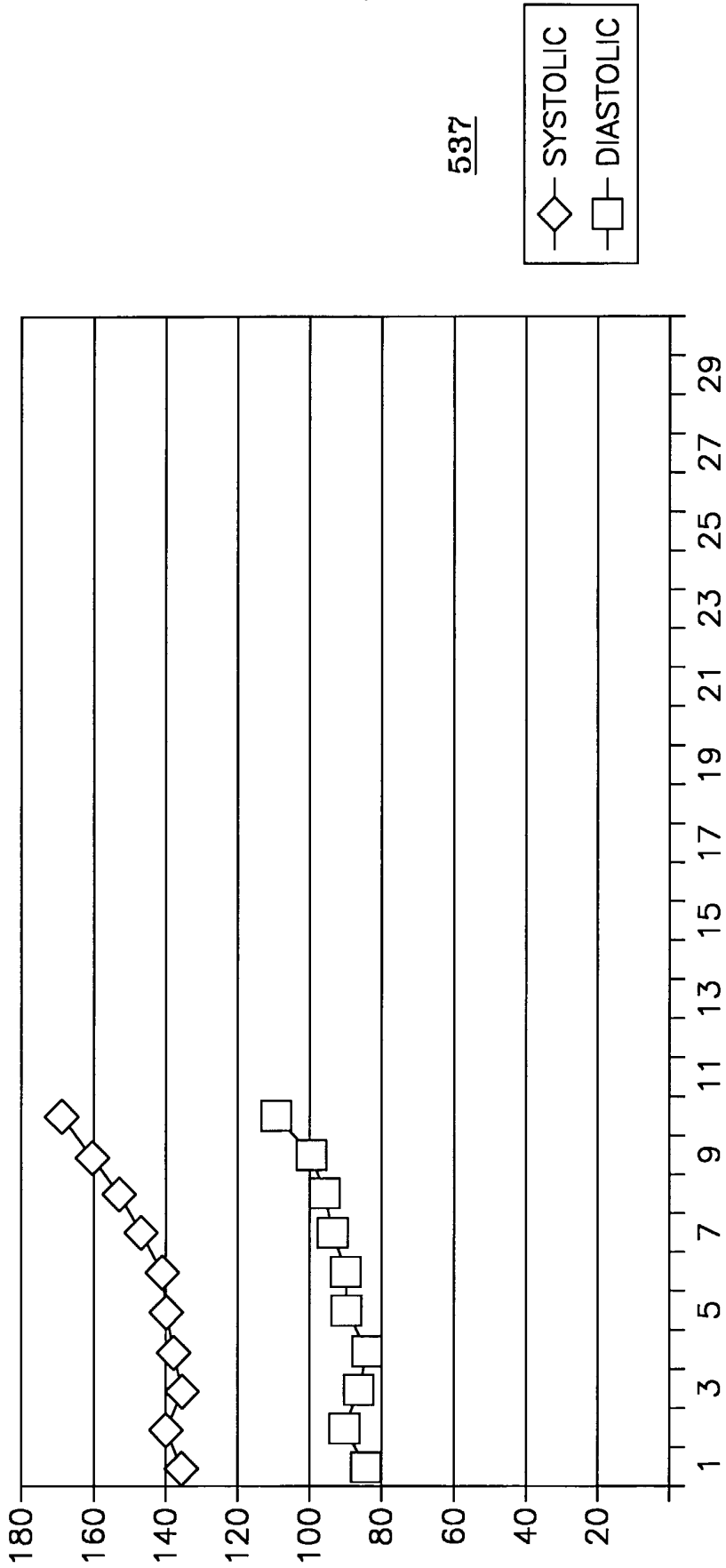

◇ SYSTOLIC  
□ DIASTOLIC

FIG-28

538

Mr. Doe, please select the title that most closely matches the problem you are having:

- Dental Pain/Problem
- Chest Pain/Discomfort
- Pain in Arm/Arms
- Dizziness
- Palpitations
- Pain in Upper Back
- Ear Pain/Problem
- Vision Problems
- Pain in Lower Back
- Headache
- Vomitting/Nausea/Diarrhea
- Pain in Leg/Legs
- Sore Throat
- Bloody Stool
- Pain in Foot/Ankle
- Cough/Congestion
- Abdominal (Belly) Pain
- Pain in Hand/Wrist

Then touch the CONTINUE button on the screen.

CONTINUE

If you make a mistake and wish to clear your selections, touch RESET.

RESET

FIG-29

539

Mr. Doe, please tell us about the chest pain you are having:

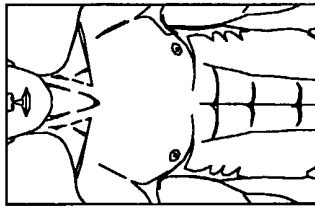

How severe is your pain?

- Severe
- Moderate
- Mild

How long have you had this pain?

- Minutes
- Hours
- Days

When did your pain begin?

- While sleeping
- While resting
- While working
- While exercising

What makes the pain worse?

- Movement
- Exertion/Lifting
- Deep Breathing
- Nothing

What makes the pain decrease?

- Movement
- Rest
- Deep Breathing
- Nothing

SEND

Then touch the SEND button on the screen.

RESET

If you make a mistake and wish to clear your selections, touch RESET.

FIG-30

PATIENT: JOHN DOE	<a href="#">Switch Patient</a> / <a href="#">Log-out</a>	COMPANY LOGO
<a href="#">History</a> / <a href="#">Physical Exam</a> / <a href="#">Diagnosis</a> / <a href="#">Rx</a> / <a href="#">Narrative</a>		
Patient's Current Medications (Click for Refills)	Hot List for Selected Diagnosis	Select Medication by:
<a href="#">Drug A</a> <a href="#">Drug B</a> <a href="#">Drug C</a> <a href="#">Drug D</a>	<a href="#">Drug E</a> <a href="#">Drug F</a> <a href="#">Drug G</a> <a href="#">Drug H</a>	<a href="#">Generic Name</a> <a href="#">Trade Name</a> <a href="#">Class</a> <a href="#">Formulary (by Class)</a>
541	ADVERTISEMENT	
Prescription Pad	John Doe	Date
<input type="button" value="Del"/> <input type="button" value="Edit"/> Drug Q (with Prescribing Parameters)	<input type="button" value="Del"/> <input type="button" value="Edit"/> Drug V (with Prescribing Parameters)	<input type="button" value="Del"/> <input type="button" value="Edit"/> Drug A (with Prescribing Parameters)
<a href="#">Physician's Name</a> / <a href="#">Signature</a>	PIN: <input type="text"/>	<input type="button" value="TRANSMIT"/> <a href="#">Physician's DEA Number</a>

FIG-31

52/52

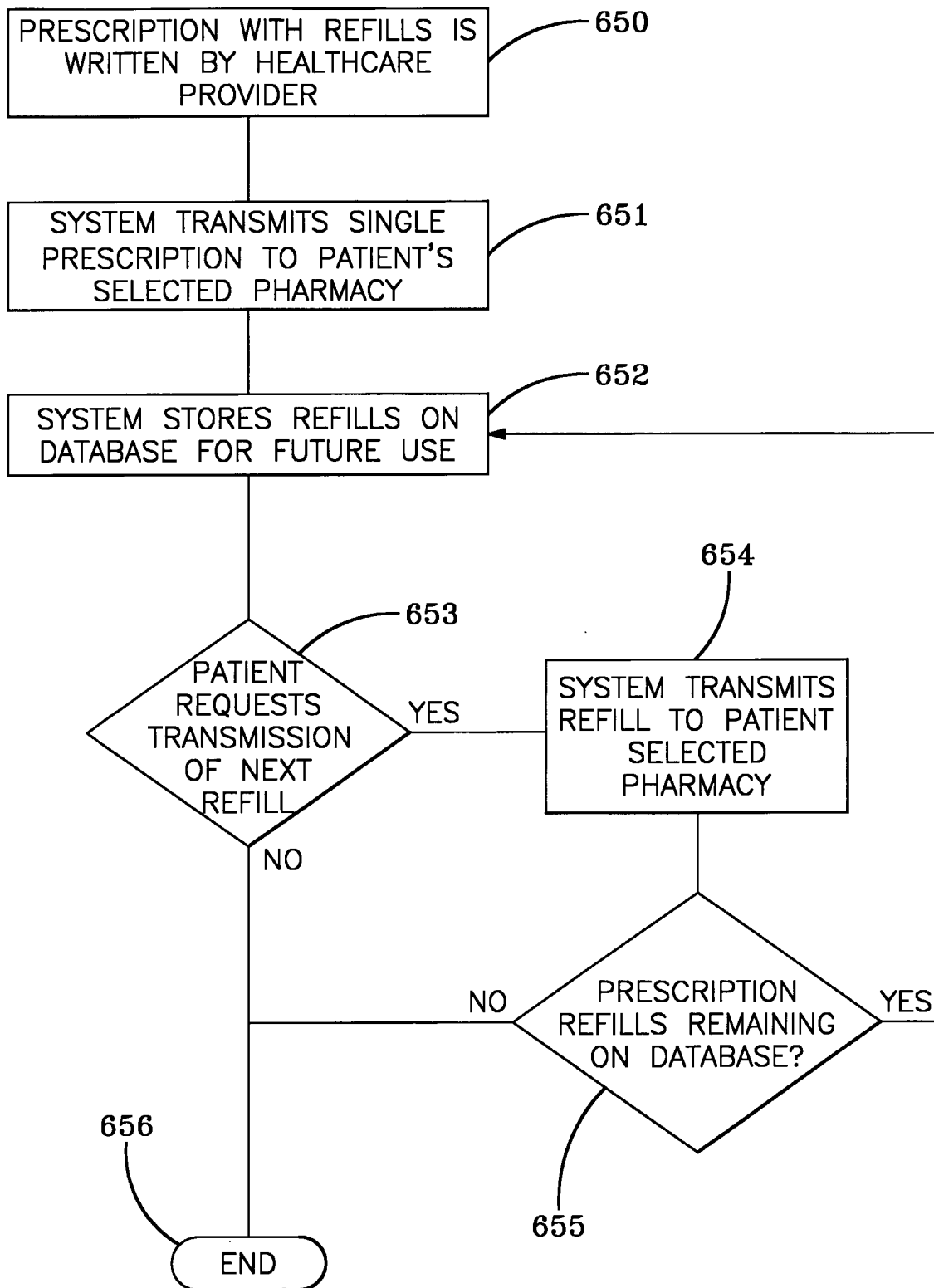

FIG-32

## INTERNATIONAL SEARCH REPORT

International application No.  
PCT/US00/31253

<b>A. CLASSIFICATION OF SUBJECT MATTER</b>		
IPC(7) : G09 B 19/00 US CL : 705/1 According to International Patent Classification (IPC) or to both national classification and IPC		
<b>B. FIELDS SEARCHED</b>		
Minimum documentation searched (classification system followed by classification symbols) U.S. : 705/1, 2, 3 434/262		
Documentation searched other than minimum documentation to the extent that such documents are included in the fields searched		
Electronic data base consulted during the international search (name of data base and, where practicable, search terms used) Proquest: Search term: "targeted health advertising" Internet: Search term: "targeted health advertising" "Dr. Koop"		
<b>C. DOCUMENTS CONSIDERED TO BE RELEVANT</b>		
Category*	Citation of document, with indication, where appropriate, of the relevant passages	Relevant to claim No.
X	US 5,951,300 A (BROWN) 14 September 1999, See Entire Reference	1-78
Y	US 5,879,163 A (BROWN ET AL.) 09 March 1999, See Entire Reference	1-78
Y	Inc. Magazine "Dr. Koop's Prescription for successful self-branding", published October 1999, See Entire Article	1-78
Y	Schultz, Stacey: "No Miracle cure", published in US News and World Report, August 10, 1998, See Entire Article	1-78
Y	Website screenshot of "DrKoop.com", printed December 20, 2000. Copyright listed as 1998-2000. See Entire Document.	1-78
<input type="checkbox"/> Further documents are listed in the continuation of Box C. <input type="checkbox"/> See patent family annex.		
* "A" "E" "L" "O" "P"	Special categories of cited documents: document defining the general state of the art which is not considered to be of particular relevance earlier document published on or after the international filing date document which may throw doubts on priority claim(s) or which is cited to establish the publication date of another citation or other special reason (as specified) document referring to an oral disclosure, use, exhibition or other means document published prior to the international filing date but later than the priority date claimed	"T" later document published after the international filing date or priority date and not in conflict with the application but cited to understand the principle or theory underlying the invention "X" document of particular relevance; the claimed invention cannot be considered novel or cannot be considered to involve an inventive step when the document is taken alone "Y" document of particular relevance; the claimed invention cannot be considered to involve an inventive step when the document is combined with one or more other such documents, such combination being obvious to a person skilled in the art "&" document member of the same patent family
Date of the actual completion of the international search 21 DECEMBER 2000		Date of mailing of the international search report 23 FEB 2001
Name and mailing address of the ISA/US Commissioner of Patents and Trademarks Box PCT Washington, D.C. 20231 Facsimile No. (703) 305-3230		Authorized officer SAM RIMELL <i>James R. Matthews</i> Telephone No. (703) 306-5626