

(12) INTERNATIONAL APPLICATION PUBLISHED UNDER THE PATENT COOPERATION TREATY (PCT)

(19) World Intellectual Property Organization
International Bureau



(43) International Publication Date
30 October 2003 (30.10.2003)

PCT

(10) International Publication Number
WO 03/088834 A1

(51) International Patent Classification ⁷ :	A61B 5/00	10/335,218	31 December 2002 (31.12.2002)	US
		10/335,211	31 December 2002 (31.12.2002)	US
(21) International Application Number:	PCT/US03/12381	10/335,257	31 December 2002 (31.12.2002)	US
		10/335,217	31 December 2002 (31.12.2002)	US
(22) International Filing Date:	21 April 2003 (21.04.2003)	10/335,212	31 December 2002 (31.12.2002)	US
		10/335,241	31 December 2002 (31.12.2002)	US
(25) Filing Language:	English	10/335,183	31 December 2002 (31.12.2002)	US
		10/335,082	31 December 2002 (31.12.2002)	US
(26) Publication Language:	English	10/335,240	31 December 2002 (31.12.2002)	US
		10/335,259	31 December 2002 (31.12.2002)	US
		10/335,182	31 December 2002 (31.12.2002)	US
(30) Priority Data:				
10/127,395	19 April 2002 (19.04.2002)	US		
60/393,707	1 July 2002 (01.07.2002)	US		
60/393,706	1 July 2002 (01.07.2002)	US		
10/237,261	5 September 2002 (05.09.2002)	US		
60/422,988	1 November 2002 (01.11.2002)	US		
60/424,429	6 November 2002 (06.11.2002)	US		
60/428,084	20 November 2002 (20.11.2002)	US		
10/335,219	31 December 2002 (31.12.2002)	US		
10/335,052	31 December 2002 (31.12.2002)	US		
10/335,073	31 December 2002 (31.12.2002)	US		
10/335,220	31 December 2002 (31.12.2002)	US		
10/335,252	31 December 2002 (31.12.2002)	US		
		(71) Applicant (for all designated States except US):		
		PELIKAN TECHNOLOGIES, INC. [US/US]; 1072 East Meadow Circle, Palo Alto, CA 94303 (US).		
		(72) Inventors; and		
		(75) Inventors/Applicants (for US only):		
		BOECKER, Dirk [DE/US]; 1652 Castilleja Avenue, Palo Alto, CA 94306 (US). ALDEN, Don [US/US]; 1312 Nelson Way, Sunnyvale, CA 94087 (US). FREEMAN, Dominique, M. [GB/US]; 4545 La Honda Road, La Honda, CA 94020 (US). WITTIG, Michael [US/US]; 1072 East Meadow Circle, Palo Alto, CA 94303 (US). CAINE,		

[Continued on next page]

(54) Title: METHOD AND APPARATUS FOR A MULTI-USE BODY FLUID SAMPLING DEVICE

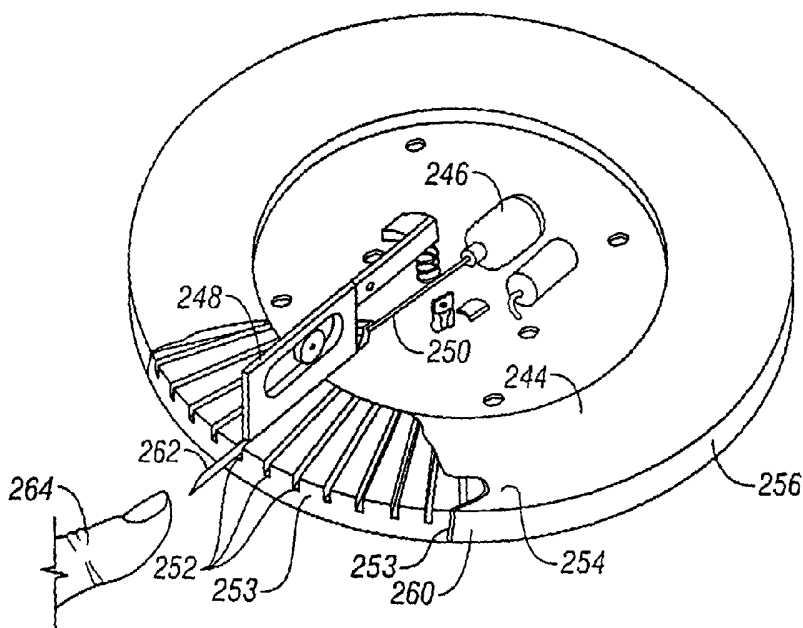

(57) Abstract: A device for use with a penetrating member (300) driver to penetrate tissue is provided. The device includes a single cartridge (12) coupled to a plurality of penetrating members (18) and operatively couplable to the penetrating member (300) driver. The penetrating members are movable to extend radially outward from the cartridge (12) to penetrate tissue. A plurality of optical analyte detecting members (not labeled) are coupled to the single cartridge (12) and positioned to receive body fluid from a wound in the tissue created by the penetrating member (262).



WO 03/088834 A1



Michael [GB/GB]; Comberton Road Toft at the Old Horse Yard, Cambridge CB3 7RY (GB). **BEADMAN, Michael** [GB/GB]; Comberton Road Toft at the Old Horse Yard, Cambridge, CB37RY (GB). **SCHUMANN, Matt** [GB/GB]; Comberton Road Toft at the Old Horse Yard, Cambridge, CB37RY (GB).

(74) **Agent:** **TUNG, Hao, Y.**; Heller, Ehrman White & McAuliffe LLP, 275 Middlefield Road, Menlo Park, CA 94025-3506 (US).

(81) **Designated States (national):** AE, AG, AL, AM, AT (utility model), AT, AU, AZ, BA, BB, BG, BR, BY, BZ, CA, CH, CN, CO, CR, CU, CZ (utility model), CZ, DE (utility model), DE, DK (utility model), DK, DM, DZ, EC, EE (utility model), EE, ES, FI (utility model), FI, GB, GD, GE, GH, GM, HR, HU, ID, IL, IN, IS, JP, KE, KG, KP, KR, KZ, LC, LK, LR, LS, LT, LU, LV, MA, MD, MG, MK, MN, MW, MX, MZ, NO, NZ, OM, PH, PL, PT, RO, RU, SC,

SD, SE, SG, SK (utility model), SK, SL, TJ, TM, TN, TR, TT, TZ, UA, UG, US, UZ, VC, VN, YU, ZA, ZM, ZW.

(84) **Designated States (regional):** ARIPO patent (GH, GM, KE, LS, MW, MZ, SD, SL, SZ, TZ, UG, ZM, ZW), Eurasian patent (AM, AZ, BY, KG, KZ, MD, RU, TJ, TM), European patent (AT, BE, BG, CH, CY, CZ, DE, DK, EE, ES, FI, FR, GB, GR, HU, IE, IT, LU, MC, NL, PT, RO, SE, SI, SK, TR), OAPI patent (BF, BJ, CF, CG, CI, CM, GA, GN, GQ, GW, ML, MR, NE, SN, TD, TG).

Published:

- *with international search report*
- *before the expiration of the time limit for amending the claims and to be republished in the event of receipt of amendments*

For two-letter codes and other abbreviations, refer to the "Guidance Notes on Codes and Abbreviations" appearing at the beginning of each regular issue of the PCT Gazette.

METHOD AND APPARATUS FOR A MULTI-USE BODY FLUID SAMPLING DEVICE

5

BACKGROUND OF THE INVENTION

Lancing devices are known in the medical health-care products industry for piercing the skin to produce blood for analysis. Typically, a drop of blood for this type of analysis is obtained by making a small incision in the fingertip, creating a small wound, which generates a small blood droplet on the surface of the skin.

10

Early methods of lancing included piercing or slicing the skin with a needle or razor. Current methods utilize lancing devices that contain a multitude of spring, cam and mass actuators to drive the lancet. These include cantilever springs, diaphragms, coil springs, as well as gravity plumbs used to drive the lancet. The device may be held against the skin and mechanically triggered to ballistically launch the lancet. Unfortunately, the pain associated with each lancing event using known technology discourages patients from testing. In addition to vibratory stimulation of the skin as the driver impacts the end of a launcher stop, known spring based devices have the possibility of firing lancets that harmonically oscillate against the patient tissue, causing multiple strikes due to recoil. This recoil and multiple strikes of the lancet is one major impediment to patient compliance with a structured glucose monitoring regime.

20

Another impediment to patient compliance is the lack of spontaneous blood flow generated by known lancing technology. In addition to the pain as discussed above, a patient may need more than one lancing event to obtain a blood sample since spontaneous blood generation is unreliable using known lancing technology. Thus the pain is multiplied by the number of attempts required by a patient to successfully generate spontaneous blood flow.

25

Different skin thickness may yield different results in terms of pain perception, blood yield and success rate of obtaining blood between different users of the lancing device. Known devices poorly account for these skin thickness variations.

30

A still further impediment to improved compliance with glucose monitoring are the many steps and inconvenience associated with each lancing event. Many diabetic patients that are insulin dependent may need to self-test for blood glucose levels five to six times daily. The large number of steps required in traditional methods of glucose testing, ranging from lancing, to milking of blood, applying blood to a test strip, and getting the measurements from the test strip, discourages many diabetic patients from testing their blood glucose levels as often as

recommended. Older patients and those with deteriorating motor skills encounter difficulty loading lancets into launcher devices, transferring blood onto a test strip, or inserting thin test strips into slots on glucose measurement meters. Additionally, the wound channel left on the patient by known systems may also be of a size that discourages those who are active with their hands or who are worried about healing of those wound channels from testing their glucose levels.

SUMMARY OF THE INVENTION

The present invention provides solutions for at least some of the drawbacks discussed above. Specifically, some embodiments of the present invention provide a multiple lancet solution to measuring analyte levels in the body. The invention may use a high density design. At least some of these and other objectives described herein will be met by embodiments of the present invention.

These and other objects of the present invention are achieved in a device for use with a penetrating member driver to penetrate tissue. The device includes a single cartridge coupled to a plurality of penetrating members and operatively couplable to the penetrating member driver. The penetrating members are movable to extend radially outward from the cartridge to penetrate tissue;. A plurality of optical analyte detecting members are coupled to the single cartridge and positioned to receive body fluid from a wound in the tissue created by the penetrating member.

In another embodiment of the present invention, a device for use with a penetrating member driver to penetrate tissue includes a single cartridge that has a plurality of openings. A plurality of penetrating members each have sharpened tips that are movable to penetrate tissue. A plurality of optical analyte detecting members are coupled to the single cartridge. A sterility barrier covers the openings.

In another embodiment of the present invention, a device for use with a penetrating member driver to penetrate tissue includes a single cartridge that has a plurality of cavities. A plurality of penetrating members are coupled to the single cartridge and are couplable to the penetrating member driver. The penetrating members are movable to extend outward to penetrate tissue. A plurality of optical analyte detecting members are coupled to the single cartridge. The analyte detecting members receive body fluid entering the cavities.

In another embodiment of the present invention, a device for use with a penetrating member driver to penetrate tissue includes a single cartridge that has a plurality of openings and a plurality of penetrating member cavities. A plurality of penetrating members are at least

partially contained in the cavities. A plurality of analyte detecting members are attached to a substrate that is couplable to the single cartridge in a manner to position at least one of the analyte detecting members with each of the plurality of cavities.

In another embodiment of the present invention, a device for use with a penetrating member driver to penetrate tissue includes a single cartridge that has a plurality of openings and a plurality of cavities. A plurality of penetrating members are provided. At least one penetrating member is in at least one of the cavities. A plurality of analyte detecting members on a layer of material are couplable to the single cartridge. At least two of the cavities each have at least one analyte detecting member in fluid communication with one of the cavities. The analyte detecting members are positioned on the cartridge to receive body fluid from a wound in the tissue created by the penetrating member.

In another embodiment of the present invention, a device includes a single cartridge. At least 50 penetrating members are coupled to and at least partially housed in the single cartridge. The cartridge has a diameter that is no greater than about 5 inches. At least 50 optical analyte detecting members are provided. Each analyte detecting member is associated with one of the penetrating members. The penetrating members are movable in an outward direction from the cartridge to penetrate tissue when actuated by the penetrating member driver.

In another embodiment of the present invention, a device includes a single cartridge. At least 100 penetrating members are coupled to and at least partially housed in the single cartridge. The cartridge has a diameter that is no greater than 6 inches. At least 100 optical analyte detecting members are provided. Each analyte detecting member is associated with one of the penetrating members. The penetrating members are movable in an outward direction from the cartridge to penetrate tissue when actuated by the penetrating member driver.

In another embodiment of the present invention, a method provides a cartridge that has a plurality of penetrating members and a plurality of optical analyte detecting members. A penetrating member driver is used to actuate the penetrating members to penetrate tissue. Used penetrating members and analyte detecting members remain coupled to the cartridge. The cartridge that contains the used penetrating members and used analyte detecting members is disposable. The entire cartridge is replaced by inserting a new cartridge, with penetrating members and analyte detecting members, into the penetrating member driver.

In another embodiment of the present invention, a lancing system includes a penetrating member driver and a plurality of penetrating members in a disc-shaped housing. A penetrating member release device releases the penetrating member from a sterile environment prior to use

and moves the penetrating member into position to be operatively coupled to the penetrating member driver. A plurality of sampling modules are included. Each module is coupled to one of the penetrating members and housed in the disc-shaped housing.

In another embodiment of the present invention, a lancing system for use with a penetrating member driver includes means for housing a plurality of penetrating members and optical analyte detecting members. Means are provided for releasing one of the penetrating member from a sealed enclosure on the housing means. Means operatively couple one of the penetrating member to the penetrating member driver. One of the optical analyte detecting members receives body fluid from a wound created in the tissue by one of the penetrating members.

In another embodiment of the present invention, a body fluid sampling system includes a cartridge. A plurality of penetrating members are coupled to the cartridge and are selectively actuatable to penetrate tissue. The penetrating members extend radially outward to penetrate tissue. A plurality of optical analyte detecting members are coupled to the cartridge. An electrically powered drive force generator is configured to drive one of the penetrating members in a launch position into a tissue site.

In another embodiment of the present invention, a device for use in penetrating tissue to obtain a body fluid sample includes a cartridge that has a plurality of cavities. A plurality of penetrating members each having sharpened tips and are slidably coupled to the cartridge. Each penetrating member is moveable relative to the other ones of the penetrating members along a path out of the cartridge to penetrate tissue. A plurality of optical analyte detecting members are included. At least one of the analyte detecting members is positioned to receive body fluid when one of the penetrating members creates a wound in the tissue. The penetrating members are arranged with the sharpened tips pointing radially outward. Each of the cavities is defined in part by a deflectable portion. The deflectable portion in a first position prevents the penetrating member from exiting the cartridge and the deflectable portion is movable to a second position to create an opening that allows the lancet to extend outward from the cartridge.

In another embodiment of the present invention, a manufacturing method provides a cartridge that has a plurality of cavities for holding penetrating members. A plurality of cavities are sealed with a sterility barrier. The cartridge is provided with a plurality of optical analyte detecting members created by coupling a analyte detecting member layer to the cartridge.

In another embodiment of the present invention, a manufacturing method provides a cartridge that has a plurality of cavities at least partially holding a plurality of penetrating

members. The cartridge is sterilized while each of the cavities is in a sealed condition. Analyte detecting members are added to the cavities by opening cavities in a sterile environment, coupling a analyte detecting member layer to the cartridge and resealing the cavities to maintain a sterile environment.

5 In another embodiment of the present invention, a method of driving a penetrating member into a tissue site to obtain a body fluid sample provides a single cartridge that has a plurality of penetrating members and a plurality of optical analyte detecting members. Fluid is expressed from a wound tract that is created by advancing one of the penetrating members radially outward from the cartridge into a tissue site. Fluid is drawn into the single cartridge
10 which exposes at least one of the optical analyte detecting members to the fluid.

In one aspect of the present invention, a device for use in penetrating tissue to obtain a body fluid sample is provided. A cartridge may be included. A plurality of penetrating members are slidably coupled to the cartridge. Each penetrating member has a distal end that is sufficiently sharp to pierce tissue. Each penetrating member is moveable relative to the other
15 ones of the penetrating members so that the sharpened distal ends extend radially outward to penetrate tissue. The penetrating members are elongate members without molded attachments.

The cartridge may define a plane and the penetrating members are contained in substantially the same plane. The cartridge may define a plane and the penetrating members are oriented to extend radially outward in substantially the same plane as the cartridge. The
20 penetrating members may be substantially in a common plane. The penetrating members may be arranged in a radial pattern.

The penetrating members may have notches on their surface. The penetrating members are coated with a material.

The penetrating members are coated with a material selected from the following: Teflon,
25 glass, silicon, or polymer.

The cartridge may have a flat radial configuration.

The device may further include a sterility barrier coupled to the cartridge.

The cartridge may comprise a disc-shaped housing.

The cartridge may have a plurality of cavities housing the lancets.

30 The cartridge may have a plurality of grooves housing the lancets.

The device may include a plurality of ratchet surfaces near an inner radial surface of the cartridge.

The cartridge may comprise a disc-shaped housing with a non-chamfered outer periphery.

In another embodiment of the present invention, a device is provided for use in penetrating tissue to obtain a body fluid sample. A cartridge is included that has a plurality of cavities. A plurality of bare lancets each have sharpened tips and are slidably coupled to the cartridge. Each of the bare lancets is moveable relative to the other ones of the bare lancets along a path out of the cartridge to penetrate tissue. The bare lancets are arranged with the sharpened tips pointing radially outward. Each of the cavities is defined in part by a deflectable portion. In a first position, the deflectable portion prevents the penetrating member from exiting the cartridge. The deflectable portion is movable to a second position by creating an opening that allows the lancet to extend outward from the cartridge.

The portion may be vertically deflectable. The portion may be horizontally deflectable.

The device may include a sterility barrier over a planar surface of the cartridge covering a plurality of longitudinal openings on the surface.

The device may include each deflectable portion includes a penetrable wall for receiving a sharpened tip of a used penetrating member.

In another embodiment of the present invention, a device for use in penetrating tissue to obtain a body fluid sample includes a cartridge that has a plurality of cavities. A plurality of penetrating member are slidably coupled to the cartridge. Each of the penetrating members is at least partially housed in one of the cavities and is moveable relative to the other ones of the penetrating members along a path out of the cartridge and into tissue. A sterility barrier covers a plurality of openings on the cartridge and creates a sterile environment in the plurality of cavities.

The cartridge may be a unitary body.

The sterility barrier may comprise a metallic foil.

The penetrating members may each be a unitary body without plastic molded attachments.

In another embodiment of the present invention, a device includes a single radial cartridge. A plurality of bare lancets are slidably coupled to the cartridge and are selectively actuatable to penetrate tissue. Each of the lancets has a longitudinal axis. The lancets are longitudinally oriented in order to be substantially in a common plane.

The cartridge may have a flat radial configuration.

The second barrier may cover a bottom surface of the cartridge.

The second barrier may cover a side surface of the cartridge.

In another embodiment of the present invention, a device includes a cartridge. A plurality of bare lancets are slidably coupled to the cartridge and are selectively actuatable to penetrate tissue. Each of the lancets has a longitudinal axis. A first sterility barrier is on a top surface of the cartridge. A second sterility barrier is on another surface of the cartridge.

5 In another embodiment of the present invention, an apparatus for penetrating an organism includes a penetrating member. A first surface is in physical contact with the penetrating member. A second surface is in physical contact with the penetrating member. The friction coefficient between the penetrating member and the second surface is at least 15% less than the friction coefficient between the penetrating member and the first surface.

10 The friction coefficient between the penetrating member and the second surface may be at least half the friction coefficient between the penetrating member and the first surface.

The friction coefficient between the penetrating member and the second surface may be at least one-quarter the friction coefficient between the penetrating member and the first surface.

15 The friction coefficient between the penetrating member and the second surface may be at least one-tenth the friction coefficient between the penetrating member and the first surface.

The apparatus may include a driver coupled to the first surface configured to drive the first surface and penetrating member along a longitudinal axis of the penetrating member.

20 In another embodiment of the present invention, a lancing device includes a penetrating member that has a shaft with a transverse slot configured to mate to a protuberance of a drive member.

In another embodiment of the present invention, a penetrating member includes a shaft that has a friction enhanced outer surface.

25 In another embodiment of the present invention, a device includes a cartridge that defines a plurality of cavities. A plurality of penetrating members are at least partially contained in the cavities of the single cartridge. The penetrating members are slidably movable to extend outward from the cartridge to penetrate tissue. The cavities each have a longitudinal opening that provides access to an elongate portion of the penetrating member. A sterility barrier is coupled to the cartridge. The sterility barrier covers a plurality of the longitudinal openings.

30 In another embodiment of the present invention, a device includes a cartridge that defines a plurality of cavities. A plurality of penetrating members are at least partially contained in the cavities of the single cartridge. The penetrating members are slidably movable to extend outward from lateral openings on the cartridge to penetrate tissue. A sterility barrier is coupled to the cartridge. The sterility barrier covers a plurality of the lateral openings.

In another embodiment of the present invention, a lancing system includes a cartridge. A plurality of penetrating members are coupled to the cartridge and are selectively actuatable to penetrate tissue. The penetrating members extend radially outward to penetrate tissue. An electrically powered drive force generator is operatively coupled to an active penetrating member to drive the penetrating member into a tissue site.

The system may include a penetrating member coupler attached the drive force generator, the coupler configured to establish a frictional coupling with an active one of the penetrating members.

The system may further comprise means for moving the a penetrating member into contact with an active penetrating members.

The penetrating member coupler may be vertically movable.

The system may further include an actuator for rotating the radial cartridge.

The system may include means for coupling with an active one of the penetrating members.

The system may include a penetrating member analyte detecting member positioned to monitor an active one of the penetrating members, the penetrating member analyte detecting member configured to provide information relative to a depth of penetration of a penetrating member through a skin surface.

The depth of penetration may be 100 to 2500 microns.

The depth of penetration may be 500 to 750 microns.

The depth of penetration may be no more than about 1000 microns beyond a stratum corneum thickness of a skin surface.

The depth of penetration may be no more than about 500 microns beyond a stratum corneum thickness of a skin surface.

The depth of penetration may be no more than about 300 microns beyond a stratum corneum thickness of a skin surface.

The depth of penetration may be less than a sum of a stratum corneum thickness of a skin surface and 400 microns.

The penetrating member sensor may be further configured to control velocity of a penetrating member.

The active penetrating member may move along a substantially linear path into the tissue.

The active penetrating member may move along an at least partially curved path into the tissue.

The driver may be a voice coil drive force generator.

The driver may be a rotary voice coil drive force generator.

The penetrating member sensor may be coupled to a processor with control instructions for the penetrating member driver.

5 The processor includes a memory for storage and retrieval of a set of penetrating member profiles utilized with the penetrating member driver.

The processor may be utilized to monitor position and speed of a penetrating member as the penetrating member moves in a first direction.

10 The processor may be utilized to adjust an application of force to a penetrating member to achieve a desired speed of the penetrating member.

The processor may be utilized to adjust an application of force to a penetrating member when the penetrating member contacts a target tissue so that the penetrating member penetrates the target tissue within a desired range of speed.

15 The processor may be utilized to monitor position and speed of a penetrating member as the penetrating member moves in the first direction toward a target tissue, wherein the application of a launching force to the penetrating member is controlled based on position and speed of the penetrating member.

The processor may be utilized to control a withdraw force to the penetrating member so that the penetrating member moves in a second direction away from the target tissue.

20 In the first direction, the penetrating member may move toward the target tissue at a speed that is different than a speed at which the penetrating member moves away from the target tissue. The driver may be controlled by the processor make such a move.

25 In the first direction, the penetrating member may move toward the target tissue at a speed that is greater than a speed at which the penetrating member moves away from the target tissue.

The speed of a penetrating member in the first direction may be in the range of about 2.0 to 10.0 m/sec.

30 The average velocity of the penetrating member during a tissue penetration stroke in the first direction may be about 100 to about 1000 times greater than the average velocity of the penetrating member during a withdrawal stroke in a second direction.

The penetrating member sensor may be a capacitive incremental encoder.

The penetrating member sensor may be simply an incremental encoder.

The penetrating member sensor may be an optical encoder.

The penetrating member sensor may be an interference encoder.

The penetrating member may be advanced along a path at a velocity following a lancing velocity profile.

5 The penetrating member may be a user interface configured to relay at least one of, penetrating member performance or a penetrating member setting.

10 The user interface may be configured to provide a user with at least one input selected from, depth of a penetrating member penetration, velocity of a penetrating member, a desired velocity profile, a velocity of a penetrating member into the target tissue, velocity of the penetrating member out of the target tissue, dwell time of the penetrating member in the target tissue; tent and hold characteristic of the penetrating member.

15 The user interface may provide at least one output to the user selected from, number of penetrating members available, number of penetrating members used, actual depth of penetrating member penetration on a target tissue penetrating cycle, stratum corneum thickness, force delivered on a target tissue penetrating cycle, energy used by a penetrating member driver to drive a penetrating member into the target tissue, dwell time of the penetrating member, battery status, system status, consumed energy, and speed profile of the penetrating member during a target tissue penetrating cycle.

The user interface may be selected from at least one of, a visual display selected from: an LCD, LED, TFT, and a backlit LCD display.

20 The user interface may includes an input device selected from a button, a touch pad, and a touch sensitive visual display.

The system may further include a data exchange device for coupling a penetrating member driver to support equipment.

25 The support equipment may be selected from at least one of a personal computer, modem, PDA, and a computer network.

The system may further include a data interface configured to couple the skin penetrating system to support equipment with a data interface.

30 The data interface may be selected from at least one of, Serial RS-232, modem-interface, USB, HPNA, Ethernet, optical interface, IRDA, RF interface, Bluetooth interface, cellular telephone interface, 2 way pager interface, parallel port interface standard, near field magnetic coupling, and RF transceiver.

The user interface may include a real time clock and one or more alarms to provide a user with a reminder of a next target penetrating event is needed.

In another embodiment of the present invention, a lancing system includes a cartridge that has an opening which extends through a center of the cartridge. A plurality of penetrating members are coupled to the cartridge and are selectively actuatable to penetrate tissue. The penetrating members extend radially outward to penetrate tissue. A penetrating member driver is at least partially positioned within the central opening. The driver is operatively couplable to an active penetrating member to drive the penetrating member into a tissue site.

In another embodiment of the present invention, a lancing system includes a single cartridge. A plurality of penetrating members are coupled to the single cartridge and are selectively actuatable to penetrate tissue. A drive force generator is operatively coupled to an active penetrating member to drive the penetrating member into a tissue site. A feedback loop controls the position of the active penetrating member coupled to the drive force generator.

In another embodiment of the present invention, a lancing system includes a single cartridge. A plurality of penetrating members are coupled to the single cartridge and are selectively actuatable to penetrate tissue. A drive force generator is operatively coupled to an active penetrating member to drive the penetrating member into a tissue site. The drive force generator actuates at least one of the penetrating members to follow a velocity profile.

In another embodiment of the present invention, a device includes a single cartridge. A plurality of penetrating members are coupled to the single cartridge and are couplable to a penetrating member driver. A plurality of ratchet surfaces are on the cartridge for advancing the cartridge.

In another embodiment of the present invention, a device includes a single cartridge. At least 50 penetrating members are coupled to and at least partially housed in the single cartridge. The cartridge has a diameter that is no greater than about 5 inches. The penetrating members are movable in an outward direction from the cartridge to penetrate tissue when actuated by the penetrating member driver.

In one nonlimiting example, the diameter may be no greater than about 5 cm.

A volume of the cartridge does not exceed a packing density or individual volume of about 0.5 cm³/penetrating member.

A volume of the cartridge does not exceed a packing density of about 0.1 cm³/penetrating member.

In another embodiment of the present invention, a device includes a single cartridge. At least 100 penetrating members are coupled to and at least partially housed in the single cartridge. The cartridge has a diameter that is no greater than 6 inches. The penetrating members are

movable in an outward direction from the cartridge to penetrate tissue when actuated by the penetrating member driver.

In another embodiment of the present invention, a lancing system includes a plurality of cartridges. Each cartridge includes a plurality of penetrating members coupled to the cartridge
5 and couplable to a penetrating member driver. A cartridge loading device moves at least one of the cartridges to be operatively coupled to the penetrating member driver.

In another embodiment of the present invention, a lancing device includes a penetrating member cartridge. Penetrating members are retractable and held within the cartridge so that they can not be used again.

10 In another embodiment of the present invention, a lancing device includes a cartridge. A foil or seal is provided and broken by a mechanism other than a penetrating member.

In another embodiment of the present invention, a lancing system for use with a plurality of penetrating members includes a penetrating member driver. A cartridge houses the plurality of penetrating members. A penetrating member release device releases one of the penetrating
15 members from a sterile environment prior to use. A penetrating member coupling device is provided. The cartridge is positionable for one of the penetrating members to engage the coupler and be operatively coupled to the penetrating member driver.

In another embodiment of the present invention, a manufacturing method provides a cartridge that has a plurality of cavities for holding penetrating members. A plurality of cavities
20 are sealed with a seal layer. A plurality of analyte detecting members are provided by coupling a analyte detecting member layer to the cartridge.

In another embodiment of the present invention, a manufacturing method provides a cartridge that has a plurality of cavities for holding penetrating members. The cartridge is
sterilized while each of the cavities is in a sealed condition. The cartridge contains at least one
25 penetrating member. A sterility barrier is applied to the cartridge. The barrier covers a plurality of cavities.

In another embodiment of the present invention, a method transports a plurality of penetrating members, each in a sterilized environment, towards a penetrating member launch
position. One of the penetrating members is released from a sterilized environment prior to
30 actuation. The penetrating member is moved to the launch position to be operatively coupled to the penetrating member driver.

In another embodiment of the present invention, a method provides a penetrating member driver. A visual display is installed on the penetrating member driver. The display is coupled to

a processor and relays penetrating member information selected from lancing performance or lancing setting.

In another embodiment of the present invention, a method provides a cartridge that has a plurality of penetrating members. A sterility barrier is penetrated. The barrier is moved clear of
5 a path of an active one of the penetrating members. A frictional coupling is formed with the active one of the penetrating members. The active one of the penetrating members is actuated.

In another embodiment of the present invention, a method provides a cartridge that has a plurality of bare lancets. A frictional coupling is formed with the active one of the bare lancets. The active one of the penetrating members is actuated.

10 These and other objects of the present invention are achieved in a device for use with a gripper. A cartridge is provided that defines a plurality of cavities. A plurality of penetrating members are at least partially contained in the cavities of the cartridge. The penetrating members are slidably movable to extend outward from the cartridge to penetrate tissue. Each cavity has a longitudinal opening that provides access to an elongate portion of the penetrating
15 member. A sterility barrier is coupled to the cartridge. The sterility barrier covers a plurality of the longitudinal openings. The sterility barrier is configured to be moved so that the elongate portion is accessed by the gripper without touching the barrier.

The cartridge may include at least one narrowed portion creating a frictional coupling with one of the penetrating members.

20 Each of the cavities may further include a lateral opening.

In another embodiment of the present invention, a device for use in penetrating tissue to obtain a body fluid sample includes a cartridge and a plurality of penetrating members slidably coupled to the cartridge. Each penetrating member has a distal end sufficiently sharp to pierce tissue. Each penetrating member is moveable relative to the other ones so that the distal end of
25 the respective penetrating member is movable to penetrate tissue. Each penetrating member is a bare lancet and does not penetrate an outer sterility barrier during actuation.

In another embodiment of the present invention, a device is provided with a cartridge that has a plurality of cavities. A plurality of penetrating members are at least partially contained in the cavities. The penetrating members are slidably movable to extend outward from lateral
30 openings on the cartridge to penetrate tissue. A sterility barrier is coupled to the cartridge. The sterility barrier covers a plurality of the lateral openings and is configured to be moved so that a penetrating member exits the lateral opening without contacting the barrier.

The sterility barrier covering the lateral openings may be configured to be moved substantially vertically so that a penetrating member exits the lateral opening without contacting the barrier.

5 The sterility barrier covering the lateral openings may be configured to be punched downward so that a penetrating member exits the lateral opening without contacting the barrier.

The sterility barrier covering the lateral openings may at least partially break away so that a penetrating member exits the lateral opening without contacting the barrier.

The sterility barrier may be positioned to define a surface at an angle between about 3 degrees and 90 degrees, relative to horizontal.

10 The sterility barrier may be positioned to define a surface at an angle of about 45 degrees, relative to horizontal.

The sterility barrier may be made of a material containing one of the following: aluminum, polymer, and paper.

15 The sterility barrier may be made of a laminate made from one of the following: aluminum, polymer, and paper.

The cartridge may include at least one narrowed portion creating a frictional coupling with one of the penetrating members.

20 The cartridge includes at least one narrowed portion near a sharpened end of each of the penetrating members, the narrowed portion acting as a guide for the penetrating member during actuation.

The cartridge may include a plurality of indentations for assisting in cartridge indexing.

The cartridge may include a plurality of indentations substantially adjacent an inner radial surface of the cartridge for assisting in cartridge indexing.

25 The cartridge may include a plurality of indentations on the cartridge for assisting in cartridge indexing, wherein the indentations are not located on an outer peripheral surface of the cartridge.

The cartridge may include a plurality of notches positioned to gather excess material from the sterility barrier.

30 The plurality of penetrating members may have sharpened tips pointed radially inward and the members are movable radially inward to penetrate tissue.

The cartridge may have a flat radial configuration.

The cartridge may include at least a portion having a conical configuration.

The device may have at least one empty cavity for receiving a penetrating member gripper when the cartridge may be loaded.

The plurality of penetrating members may be substantially in a common plane.

The plurality of penetrating members may be bare lancets.

5 The plurality of penetrating members may each include at least one notch to facilitate handling.

The plurality of penetrating members may include at least one bent lancet.

The cavity may include an indentation for receiving a penetrating member gripper.

Each penetrating member may rest on a protrusion in the cavity, the protrusion
10 configured to facilitate engagement of the penetrating member with a slot on a penetrating member gripper.

In another embodiment of the present invention, a device is provided with means for housing a plurality of penetrating members in a radial configuration. The penetrating members are individually couplable to a driver.

15 In another embodiment of the present invention, a lancing system includes a cartridge that defines a plurality of cavities. A plurality of penetrating members are at least partially contained in the cavities. The penetrating members are slidably movable to extend outward from lateral openings on the cartridge to penetrate tissue. A sterility barrier is coupled to the cartridge. The sterility barrier covers at least one of the lateral openings and is configured to be moved so
20 that a penetrating member exiting from the lateral opening during actuation will not contact the barrier. An electrically powered drive force generator is operatively coupled to an active one of the penetrating members to drive the active penetrating member into a tissue site.

In another embodiment of the present invention, a lancing system has a cartridge that defines a plurality of cavities. A plurality of penetrating members are at least partially contained
25 in the cavities. The penetrating members are slidably movable to extend outward from lateral openings on the cartridge to penetrate tissue. A sterility barrier is coupled to the cartridge. The sterility barrier covers at least one of the lateral openings and is configured to be moved so that a penetrating member exiting the lateral opening during actuation will not contact the barrier. A feedback loop controls trajectory of each penetrating member extending outward from the
30 cartridge during actuation.

In another embodiment of the present invention, a lancing system includes a single cartridge with a plurality of cavities. A plurality of penetrating members are at least partially contained in the cavities. The penetrating members are slidably movable to extend outward from

the cartridge to penetrate tissue. Each cavity has a longitudinal opening that provides access to an elongate portion of the penetrating member. A sterility barrier is coupled to the cartridge and covers a plurality of the longitudinal openings. A punch is movable to penetrate the sterility barrier and release one of the penetrating members from a sterile environment created by the sterility barrier.

The punch may be positioned to penetrate the sterility barrier of a cavity adjacent an active cavity.

The punch may be positioned to penetrate the sterility barrier of a cavity that may be not an active cavity.

The punch may move vertically when urged by a cam surface.

The cartridge may move vertically when urged by a cam surface.

The cam may have a radial configuration for urging the motion of the punch.

The cam may have a radial configuration for urging the motion of a cartridge pusher which in turn moves the cartridge.

The system may have a ratchet mechanism preventing a cam urging the motion of the punch from moving in reverse.

A mechanical slider may be actuated by a user, the slider configured to actuate a cam that urges the motion of the punch.

An electrically powered force generator may be used for actuating an active one of the penetrating members.

An electrically powered force generator may be used for actuating an active one of the penetrating members;

A position analyte detecting member may be coupled to the force generator used to determine position of an active one of the penetrating members.

In another embodiment of the present invention, a lancing system has a single cartridge with a plurality of cavities. A plurality of penetrating members are at least partially contained in the cavities. The penetrating members are slidably movable to extend outward from lateral openings on the cartridge to penetrate tissue. A sterility barrier is coupled to the cartridge and covers a plurality of the lateral openings. A punch is movable to penetrate the sterility barrier, and pushes the sterility barrier into a position so that the penetrating member are actuated without contacting the sterility barrier.

In another embodiment of the present invention, a device includes a single cartridge. A plurality of penetrating members are coupled to the single cartridge and are couplable to a driver.

A plurality of openings on the cartridge are configured to position the cartridge to align an unused penetrating member with the driver. An actuator is configured to engage the openings and actuate the cartridge to move the unused penetrating member into alignment with the driver.

A plurality of openings may be adjacent an inner radial surface of the cartridge.

5 The plurality of openings may be located on an underside of the cartridge.

The actuator may be electrically powered.

The actuator may be coupled to a mechanical slider actuated by a user.

The actuator may move horizontally to index the cartridge.

10 In another embodiment of the present invention, a lancing system includes a driver. A cartridge has a plurality of bare lancets coupled to the cartridge. A lancet gripper is coupled to the driver. The gripper has a slot for receiving at least one of the bare lancets. The slot creates a frictional grip with the bare lancets.

The gripper may have a tuning fork shaped configuration.

15 The gripper may move vertically relative to the lancet to engage an elongate portion of the lancet.

The gripper block may be used for coupling the gripper to a driver.

In another embodiment of the present invention, a lancing system includes a lancet driver. A plurality of lancets are in a disc-shaped housing. A lancet gripper is included. A lancet release device is provided for releasing the lancet for a sterile environment prior to use.

20 An actuator is configured to move the disc-shaped housing relative to the lancet gripper to bring one of the lancets into contact with the lancet gripper.

The lancet release device may include a punch with sufficient sharpness to penetrate a sterility barrier enclosing a cavity containing the lancet.

25 The lancet release device may include a punch with sufficient sharpness to penetrate a sterility barrier enclosing a cavity containing the lancet and shaped to urge the barrier towards the sides of the cavity.

The lancet release device may include a punch having a first portion for piercing one location of the sterility barrier and a second portion for opening a second location of the sterility barrier.

30 The lancet driver may be an electric powered driver.

The release device may comprise a movable member sufficient to pierce a lancet enclosure.

The system may further comprise a lancet coupler suitable for engaging one of the lancets and independently advancing one of the lancets along a path outward from the housing, into a target tissue, and back into the housing.

5 The system may further comprise a lancet coupler suitable for engaging one of the modules and advancing one of the modules and one of the lancets such that the one of the lances advances along a path outward from the housing, into a target tissue, and back into the housing.

In another embodiment of the present invention, a lancing system may include a lancet driver. A cartridge housing is provided with the plurality of lancets. A lancet gripper is coupled to the lancet driver. A lancet release device releases one of the lancets from a sterile
10 environment prior to use. The cartridge is movable relative to the lancet driver to engage and disengage one of the lancets from the lancet gripper.

The lancet driver and cartridge may be in the same plane.

The cartridge may move vertically relative to the lancet driver.

In another embodiment of the present invention, a lancing system is provided for use with
15 a driver and may include means for releasing a penetrating member from a sterile enclosure on a cartridge. The cartridge has a plurality of sterile enclosures and a plurality of penetrating members. Means are included for aligning and operatively coupling the penetrating member to the driver.

In another embodiment of the present invention, a method is provided for loading a
20 cartridge that has a plurality of penetrating members into a housing of a lancing apparatus. Each penetrating member is released from a sterilized environment on the cartridge. The penetrating member is transported within the housing towards a launch position. The lancet is loaded to be operatively coupled to a penetrating member driver in the apparatus.

Releasing of the penetrating member may comprise using a punch to penetrate a sterility
25 barrier of a cavity adjacent a cavity in the launch position.

Transporting may comprise rotating the cartridge to move the cavity with the released penetrating member into the launch position.

Loading may comprise creating a frictional coupling between the penetrating member and the driver.

30 Loading may comprise moving the cartridge relative to the driver to bring the driver into contact with the released penetrating member.

In another embodiment of the present invention, a method provides a cartridge that has a plurality of individually sealed cavities, each containing a penetrating member. A punch plate is

lowered to release an unused penetrating member from one of the sealed cavities. The cartridge is rotated to align the unused penetrating member with a gripper. A frictional engagement is created with the penetrating member by inserting the penetrating member into a receiving slot on the gripper.

5 In another embodiment of the present invention, a method provides a cartridge that has a plurality of cavities, each containing a penetrating member. Each member is held by a coupling to the cartridge. A penetrating member is engaged with a gripper. A first force generator is used to move the gripper in a manner sufficient to release the penetrating member from the coupling to the cartridge. A second force generator is used to move the gripper in a manner sufficient to
10 drive the penetrating member into tissue.

In another embodiment of the present invention, a method provides a cartridge that has a plurality of cavities, each containing a penetrating member. Each member is held by a coupling to the cartridge. A punch device and a penetrating member gripper are provided. Relative motion between the cartridge and the gripper is created and the cartridge is separated from the
15 gripper. Relative motion between the cartridge and the gripper is created and the gripper is aligned over an unused penetrating member in the cartridge. Relative motion between the cartridge and the gripper is created and the gripper is engaged with the unused penetrating member.

In another embodiment of the present invention, a method provides a lancet driver. A
20 visual display is installed on the lancet driver. The display is coupled to a processor, relays lancet information selected from, lancing performance or lancing setting.

In another embodiment of the present invention, a method provides a cartridge that has a plurality of cavities. A plurality of penetrating members are inserted and are at least partially contained in the cavities of the cartridge. The penetrating members are slidably movable to
25 extend outward from lateral openings on the cartridge to penetrate tissue. A sterility barrier is added to the cartridge and covers a plurality of the lateral openings.

In another embodiment of the present invention, a manufacturing method provides a cartridge that has a plurality of cavities for holding penetrating members. The cartridge is sterilized while each of the cavities is in a sealed condition. The cartridge contains a plurality of
30 penetrating members. A planar sheet of sterility barrier material is used to cover a plurality of the cavities to create a sterile environment inside each of the cavities.

In another embodiment of the present invention, a method provides a cartridge that has a plurality of bare lancets. At least a portion of a sterility barrier is moved such that an active one

of the bare lancets exits the cartridge to penetrate tissue without contacting the sterility barrier. The active one of the bare lancets is retracted back into the cartridge after penetrating tissue.

Moving may comprise using a punch to break off at least a portion of the sterility barrier.

Moving may comprise moving a punch vertically to penetrate the sterility barrier.

5 The method may further comprise moving the cartridge to align the released bare lancet with a lancet gripper.

The method may further comprise using a cam surface to move a punch to penetrate the sterility barrier.

10 The method may further comprise having a patient move a mechanical slider to actuate a cam surface that moves a punch to penetrate the sterility barrier.

These and other objects of the present invention are achieved in a device for use with a penetrating member driver to penetrate tissue. A plurality of penetrating members are coupled to a single cartridge and are operatively couplable to the penetrating member driver. The penetrating members are movable to extend radially outward from the cartridge to penetrate
15 tissue. A plurality of analyte detecting members are coupled to the single cartridge and are positioned on the cartridge to receive body fluid from a wound in the tissue created by the penetrating member.

Penetrating members may be slidably coupled to the cartridge.

20 At least one analyte detecting member may be associated with at least one of the penetrating members.

The cartridge may be a flat radial disc.

The cartridge may have a diameter of less than 6 cm.

The cartridge may have a diameter of less than 5 cm, 4 cm, 3 cm, or 2 cm.

The cartridge may be a unitary body.

25 In one embodiment, the penetrating members are not attached by a resilient member to the cartridge.

Analyte detecting members used the present invention may be electrochemical analyte detecting members.

Analyte detecting members may be potentiometric analyte detecting members.

30 Analyte detecting members may be configured to determine analyte levels using a body fluid sample of less than about 1 microliter.

Analyte detecting members may be configured to determine analyte levels using a body fluid sample of less than about 300 nanoliters.

Analyte detecting members may be mounted on the cartridge.

Each of the analyte detecting members may comprise an array of analyte detecting members.

Each of the analyte detecting members may comprise an array of analyte detecting members wherein a plurality of the array analyte detecting members have different ranges of analyte sensitivity.

Each of the analyte detecting members may comprise an array of analyte detecting members formed from nanowires.

Each of the penetrating members may be elongate members without molded attachments.

Each of the penetrating members may be elongate wires of substantially constant diameter.

Each of the penetrating members may be made of only one material selected from the following: a metal or a metal alloy.

In another embodiment of the present invention, a device for use with a penetrating member driver to penetrate tissue includes a single cartridge that has a plurality of openings. A plurality of penetrating members have sharpened tips that are movable to penetrate tissue;. A plurality of analyte detecting members are coupled to the single cartridge. A sterility barrier covers the openings.

The penetrating members may have sharpened distal ends and may be arranged in a radial pattern pointing each of the sharpened distal ends radially outward.

Analyte detecting members may be positioned on the cartridge to receive body fluid from a wound in the tissue created by a penetrating member.

Analyte detecting members may be electrochemical analyte detecting members.

Analyte detecting member may be potentiometric analyte detecting members.

The analyte detecting members may be configured to determine analyte levels using a body fluid sample of less than about 1 microliter.

The analyte detecting members may be configured to determine analyte levels using a body fluid sample of less than about 300 nanoliters.

The sterility barrier, prior to being breached, may maintain a sterile environment inside the openings.

In another embodiment of the present invention, a device for use with a penetrating member driver to penetrate tissue includes a single cartridge that has a plurality of cavities. A plurality of penetrating members are coupled to the single cartridge and are couplable to the

penetrating member driver. The penetrating members are movable to extend outward to penetrate tissue. A plurality of analyte detecting members are coupled to the single cartridge. The analyte detecting members receive body fluid that enters the cavities.

The analyte detecting members may define a portion of the cavities.

5 The analyte detecting members may be mounted in the cavities.

The device may further comprise a sterility barrier covering the cavities.

The analyte detecting members may be electrochemical analyte detecting members.

The analyte detecting member may be potentiometric analyte detecting members.

10 The analyte detecting members may be configured to determine analyte levels using a body fluid sample of less than about 1 microliter.

The analyte detecting members may be configured to determine analyte levels using a body fluid sample of less than about 300 nanoliters.

At least some of the analyte detecting members may be positioned on a bottom surface of the cavities.

15 At least some of the analyte detecting members may be positioned on a side surface of the cavities.

At least some of the analyte detecting members may be positioned on a top surface of the cavities.

20 At least some of the analyte detecting members may be positioned on a curved surface of the cavities.

In another embodiment of the present invention, a device for use with a penetrating member driver to penetrate tissue may include a single cartridge that has a plurality of openings and a plurality of penetrating member cavities. A plurality of penetrating members are at least partially contained in the cavities. A plurality of analyte detecting members are attached to a substrate. The substrate is couplable to the single cartridge in a manner that positions at least one of the analyte detecting members with each of the plurality of cavities.

The substrate may comprise a material selected from: polymer, metallic foil, or paper.

The substrate may comprise a laminate made from combinations of any of the following: polymer, metallic foil, or paper.

30 The analyte detecting members may define a portion of the cavities.

A sterility barrier may cover a plurality of the openings.

The analyte detecting members may be configured to determine analyte levels using a body fluid sample of less than about 1 microliter.

The analyte detecting members may be configured to determine analyte levels using a body fluid sample of less than about 300 nanoliters.

In another embodiment of the present invention, a device for use with a penetrating member driver to penetrate tissue may include a single cartridge that has a plurality of openings and a plurality of cavities. A plurality of penetrating members may be provided with at least one penetrating member in at least one of the cavities. A plurality of analyte detecting members are on a layer of material that is couplable to the single cartridge. At least two of the cavities each have at least one analyte detecting member in fluid communication with one of the cavities. The analyte detecting members are positioned on the cartridge to receive body fluid from a wound in the tissue created by the penetrating member.

In one nonlimiting example, the cartridge diameter may be no greater than about 5 cm.

In one embodiment, a volume of the cartridge does not exceed a packing density of about 0.5 cm³ per penetrating member and analyte detecting member.

In another embodiment, a volume of the cartridge does not exceed a packing density of about 0.1 cm³ per penetrating member and analyte detecting member.

In another embodiment of the present invention, a device includes a single cartridge. At least 50 penetrating members are coupled to and are at least partially housed in the single cartridge. The cartridge has a diameter that is no greater than about 5 inches. At least 50 analyte detecting members are included. Each analyte detecting member is associated with one of the penetrating members. The penetrating members are movable in an outward direction from the cartridge to penetrate tissue when actuated by the penetrating member driver.

In another embodiment of the present invention, a device includes a single cartridge. At least 100 penetrating members are coupled to and are at least partially housed in the single cartridge. The cartridge has a diameter that is no greater than 6 inches. At least 100 analyte detecting members are provided. Each analyte detecting member is associated with one of the penetrating members. The penetrating members are movable in an outward direction from the cartridge to penetrate tissue when actuated by the penetrating member driver.

The penetrating member driver may be an electric powered driver.

The release device may comprise a movable member sufficient to pierce a penetrating member enclosure.

A penetrating member coupler suitable for engaging one of the penetrating members and independently advancing one of the penetrating members along a path outward from the housing, into a target tissue, and back into the housing.

A sample module may have a sample chamber volume of less than 1 microliter.

A penetrating member coupler suitable for engaging one of the modules and advancing one of the modules and one of the penetrating members such that the one of the lances may advance along a path outward from the housing, into a target tissue, and back into the housing.

5 In another embodiment of the present invention, a method provides a cartridge that has a plurality of penetrating members and a plurality of analyte detecting members. A penetrating member driver is used to actuate the penetrating members to penetrate tissue. Used penetrating members and analyte detecting members remain coupled to the cartridge. The cartridge with the used penetrating members and analyte detecting members is disposable. The entire cartridge is
10 replaced by inserting a new cartridge, having penetrating members and analyte detecting members, into the penetrating member driver.

In another embodiment of the present invention, a lancing system includes a penetrating member driver. A plurality of penetrating members are in a disc-shaped housing. A penetrating member release device releases the penetrating member from a sterile environment prior to use
15 and moves the penetrating member into position to be operatively coupled to the penetrating member driver. A plurality of sampling modules are provided. Each module is coupled to one of the penetrating members and is housed in the disc-shaped housing.

In another embodiment of the present invention, a lancing system for use with a penetrating member driver includes means for housing a plurality of penetrating members and
20 analyte detecting members. Means are provided for releasing one of the penetrating member from a sealed enclosure on the housing means. Means are included for operatively coupling one of the penetrating member to the penetrating member driver. One of the analyte detecting members receives body fluid from a wound that is created in the tissue by one of the penetrating members.

25 In another embodiment of the present invention, a body fluid sampling system includes a cartridge. A plurality of penetrating members are coupled to the cartridge and are selectively actuatable to penetrate tissue. The penetrating members extend radially outward to penetrate tissue. A plurality of analyte detecting members are coupled to the cartridge. An electrically powered drive force generator is configured to drive one of the penetrating members in a launch
30 position into a tissue site.

The drive force generator may be configured to sequentially drive the penetrating members, each of the members moved from the launch position along a path into and out of the tissue site.

The system may further comprise a penetrating member coupler attached the drive force generator, the coupler configured to establish a frictional coupling with one of the penetrating members in the launch position.

5 The system may further comprise means for moving the a penetrating member into contact with a coupler of the drive force generator.

The penetrating member coupler may be vertically movable.

The system may further comprise an actuator for rotating the radial cartridge.

The system may further comprise means for coupling the force generator with one of the penetrating members.

10 The system may further comprise a penetrating member sensor positioned to monitor a penetrating member coupled to the force generator, the penetrating member sensor configured to provide information relative to a depth of penetration of a penetrating member through a skin surface.

The depth of penetration may be about 100 to 2500 microns.

15 The depth of penetration may be about 500 to 750 microns.

The depth of penetration may be, in this nonlimiting example, no more than about 1000 microns beyond a stratum corneum thickness of a skin surface.

The depth of penetration may be no more than about 500 microns beyond a stratum corneum thickness of a skin surface.

20 The depth of penetration may be no more than about 300 microns beyond a stratum corneum thickness of a skin surface.

The depth of penetration may be less than a sum of a stratum corneum thickness of a skin surface and 400 microns.

25 The penetrating member sensor may be further configured to control velocity of a penetrating member.

The active penetrating member may move along a substantially linear path into the tissue.

The active penetrating member may move along an at least partially curved path into the tissue.

The driver may be a voice coil drive force generator.

30 The driver may be a rotary voice coil drive force generator.

The penetrating member sensor may be coupled to a processor with control instructions for the penetrating member driver.

The processor may include a memory for storage and retrieval of a set of penetrating member profiles utilized with the penetrating member driver.

The processor may be utilized to monitor position and speed of a penetrating member as the penetrating member moves in a first direction.

5 The processor may be utilized to adjust an application of force to a penetrating member to achieve a desired speed of the penetrating member.

The processor may be utilized to adjust an application of force to a penetrating member when the penetrating member contacts a target tissue so that the penetrating member penetrates the target tissue within a desired range of speed.

10 The processor may be utilized to monitor position and speed of a penetrating member as the penetrating member moves in the first direction toward a target tissue, wherein the application of a launching force to the penetrating member is controlled based on position and speed of the penetrating member.

The processor may be utilized to control a withdraw force to the penetrating member so
15 that the penetrating member moves in a second direction away from the target tissue.

In the first direction, the penetrating member may move toward the target tissue at a speed that is different than a speed at which the penetrating member moves away from the target tissue.

In the first direction the penetrating member may move toward the target tissue at a speed
20 that is greater than a speed at which the penetrating member moves away from the target tissue.

The speed of a penetrating member in the first direction may be the range of about 2.0 to 10.0 m/sec.

The average velocity of the penetrating member during a tissue penetration stroke in the first direction may be about 100 to about 1000 times greater than the average velocity of the
25 penetrating member during a withdrawal stroke in a second direction.

The penetrating member sensor may include a capacitive incremental encoder.

The penetrating member sensor may include an incremental encoder.

The penetrating member sensor may include an optical encoder.

The penetrating member sensor may include an interference encoder.

30 The penetrating member may be advanced along a path at a velocity following a lancing velocity profile.

The system may further comprise a user interface configured to relay at least one of, penetrating member performance or a penetrating member setting.

The user interface may be configured to provide a user with at least one input selected from, depth of a penetrating member penetration, velocity of a penetrating member, a desired velocity profile, a velocity of a penetrating member into the target tissue, velocity of the penetrating member out of the target tissue, dwell time of the penetrating member in the target tissue; tent and hold characteristic of the penetrating member.

The user interface may provide at least one output to the user selected from, number of penetrating members available, number of penetrating members used, actual depth of penetrating member penetration on a target tissue penetrating cycle, stratum corneum thickness, force delivered on a target tissue penetrating cycle, energy used by a penetrating member driver to drive a penetrating member into the target tissue, dwell time of the penetrating member, battery status, system status, consumed energy, and speed profile of the penetrating member during a target tissue penetrating cycle.

The user interface may be selected from at least one of, a visual display selected from: an LCD, LED, TFT, and a backlit LCD display.

The user interface may include an input device selected from a button, a touch pad, and a touch sensitive visual display.

The system may further comprise a data exchange device for coupling a penetrating member driver to support equipment.

The support equipment may be selected from at least one of a personal computer, modem, PDA, and a computer network.

The system may further comprise a data interface configured to couple the skin penetrating system to support equipment with a data interface.

The data interface may be selected from at least one of, Serial RS-232, modem interface, USB, HPNA, Ethernet, optical interface, IRDA, RF interface, Bluetooth interface, cellular telephone interface, 2 way pager interface, parallel port interface standard, near field magnetic coupling, and RF transceiver.

The user interface may include a real time clock and one or more alarms to provide a user with a reminder of a next target penetrating event may be needed.

The analyte detecting members may be electrochemical analyte detecting members.

The analyte detecting member may be potentiometric analyte detecting members.

The analyte detecting members may be configured to determine analyte levels using a body fluid sample of less than about 1 microliter.

The analyte detecting members may be configured to determine analyte levels using a body fluid sample of less than about 300 nanoliters.

The analyte detecting members may be mounted on the cartridge.

Each of the analyte detecting members may comprise an array of analyte detecting
5 members.

Each of the analyte detecting members may comprise an array of analyte detecting members wherein a plurality of the array analyte detecting members have different ranges of analyte sensitivity.

Each of the analyte detecting members may comprise an array of analyte detecting
10 members formed from nanowires.

Each of the penetrating members may be elongate members without molded attachments.

Each of the penetrating members may be elongate wires of substantially constant diameter.

Each of the penetrating members may be made of only one material selected from the
15 following: a metal or a metal alloy.

In another embodiment of the present invention, a device for use in penetrating tissue to obtain a body fluid sample includes a cartridge that has a plurality of cavities. A plurality of penetrating members have sharpened tips and are slidably coupled to the cartridge. Each penetrating member is moveable relative to the other ones of the penetrating members along a
20 path out of the cartridge to penetrate tissue. A plurality of analyte detecting members are included. At least one of the analyte detecting members is positioned to receive body fluid when one of the penetrating members creates a wound in the tissue. The penetrating members are arranged with the sharpened tips pointing radially outward. Each of the cavities is defined in part by a deflectable portion. In a first position, the deflectable portion prevents the penetrating
25 member from exiting the cartridge. The deflectable portion is movable to a second position to create an opening that allows the lancet to extend outward from the cartridge.

The deflectable portion may be vertically deflectable.

The deflectable portion may be horizontally deflectable.

The device may further comprise a sterility barrier over a planar surface of the cartridge
30 covering a plurality of longitudinal openings on the surface.

Each deflectable portion may include a penetrable wall for receiving a sharpened tip of a used penetrating member.

The device may further comprise a module mounted about one of the penetrating member and having at least one of the analyte detecting members.

The device may further comprise a module slidably mounted about one of the penetrating member and having at least one of the analyte detecting members, the module movable to be adjacent the wound in the tissue.

In another embodiment of the present invention, a manufacturing method provides a cartridge that has a plurality of cavities for holding penetrating members. A plurality of cavities are sealed with a sterility barrier. The cartridge may be provided with a plurality of analyte detecting members by coupling a analyte detecting member layer to the cartridge.

The analyte detecting member layer may comprise the analyte detecting members secured to a material selected from the following: polymer, foil, or paper.

The analyte detecting members may be electrochemical analyte detecting members.

The sealing creates a sterile environment in the cavities.

The method may comprise applying a second sterility barrier to the cartridge.

In another embodiment of the present invention, a manufacturing method provides a cartridge that has a plurality of cavities at least partially holding a plurality of penetrating members. The cartridge is sterilized while each of the cavities is in a sealed condition. Analyte detecting members are added to the cavities by opening cavities in a sterile environment, coupling a analyte detecting member layer to the cartridge that provides the analyte detecting members, and resealing the cavities to maintain a sterile environment.

The method may further comprise adding a sterility barrier to the cartridge.

The method may further comprise providing for step may comprise adding a sterility barrier covering the cavities prior to sterilizing.

The method may further comprise analyte detecting members or detecting members that include components that cannot withstand a penetrating member sterilization process.

In another embodiment of the present invention, a method of driving a penetrating member into a tissue site to obtain a body fluid sample provides a single cartridge that has a plurality of penetrating members and a plurality of analyte detecting members. Fluid is expressed from a wound tract that is created by advancing one of the penetrating members radially outward from the cartridge into a tissue site. Fluid is drawn into the single cartridge which exposes at least one of the analyte detecting members to the fluid.

The method may use an electric powered drive force generator for advancing the penetrating member.

The cartridge may have a disc-shaped configuration.

Each of the penetrating members may be elongate members without molded attachments.

Each of the penetrating members may be elongate wires of substantially constant diameter.

5 In one embodiment, each of the penetrating members is made of only one material selected from the following: a metal or a metal alloy.

The cartridge may have a radial configuration and is rotated to bring an unused penetrating member into a launch position for a drive force generator.

10 Any embodiment of the present invention may include a user interface configured to relay at least one of, penetrating member performance or a penetrating member setting.

The user interface may be configured to provide a user with at least one input selected from, depth of a penetrating member penetration, velocity of a penetrating member, a desired velocity profile, a velocity of a penetrating member into the target tissue, velocity of the penetrating member out of the target tissue, dwell time of the penetrating member in the target
15 tissue, and a target tissue relaxation parameter.

The user interface may provide at least one output to the user selected from, number of penetrating members available, number of penetrating members used, actual depth of penetrating member penetration on a target tissue, stratum corneum thickness, force delivered on a target tissue, energy used by a penetrating member driver to drive a penetrating member into the target
20 tissue, dwell time of the penetrating member, battery status, system status, consumed energy, speed profile of a penetrating member, information relative to contact of a penetrating member with target tissue before penetration by the penetrating member, and information relative to a change of speed of a penetrating member as in travels in the target tissue.

The user interface may include a real time clock and one or more alarms to provide a user
25 with a reminder of a next target penetrating event is needed.

The system may have a processor coupled to the penetrating member driver and configured to receive signals from the user interface.

The processor may be configured to assist in an adjustment of force applied to the penetrating member driver in response to a target tissue parameter. A user interface processor
30 may be coupled to the user interface. A memory for storing a target tissue parameter may be included. A memory for storing data on target tissue penetrating performance may be included.

The system may include a memory for storing at least one of, a number of penetrating members used, number of target tissue penetrating events, time and date of the last selected

number of target tissue penetrating events, time interval between alarm and target tissue penetrating event, stratum corneum thickness, time of day, energy consumed by a penetrating member driver to drive a penetrating member into the target tissue, depth of penetrating member penetration, velocity of the penetrating member, a desired velocity profile, velocity of the penetrating member into the target tissue, velocity of the penetrating member out of the target tissue, dwell time of the penetrating member in the target tissue, a target tissue relaxation parameter, force delivered on the target tissue, dwell time of the penetrating member, battery status, system status, consumed energy, speed profile of the penetrating member as the penetrating member penetrates and advances through the target tissue, a target tissue relaxation parameter, information relative to contact of a penetrating member with target tissue before penetration by the penetrating member, information relative to a change of speed of a penetrating member as it travels in the target tissue, information relative to consumed analyte detecting members and information relative to consumed penetrating members. A display or other output device as will be apparent to one of skill in the art may be used to relay information in memory to the user.

The user interface may respond to audio commands.

The user interface may include an analyte detecting member for detecting audio commands.

The user interface may relay information to a user via an audio device.

The user interface may relay information to a user via a wireless device.

A further understanding of the nature and advantages of the invention will become apparent by reference to the remaining portions of the specification and drawings.

BRIEF DESCRIPTION OF THE DRAWINGS

Figure 1 is a perspective view illustrating a system, according to an embodiment for use in piercing skin to obtain a blood sample;

Figure 2 is a plan view of a portion of a replaceable penetrating member cartridge forming part of the system;

Figure 3 is a cross-sectional end view on 3-3 in Figure 2;

Figure 4 is a cross-sectional end view on 4-4 in Figure 2;

Figure 5 is a perspective view of an apparatus forming part of the system and used for manipulating components of the cartridge, illustrating pivoting of a penetrating member accelerator in a downward direction;

Figure 6A is a view similar to Figure 5, illustrating how the cartridge is rotated or advanced;

Figure 6B is a cross-sectional side view illustrating how the penetrating member accelerator allows for the cartridge to be advanced;

5 Figure 7A and 7B are views similar to Figures 6A and 6B, respectively, illustrating pivoting of the penetrating member accelerator in an opposite direction to engage with a select one of the penetrating members in the cartridge;

Figures 8A and 8B are views similar to Figures 7A and 7B, respectively, illustrating how the penetrating member accelerator moves the selected penetrating member to pierce skin;

10 Figures 9A and 9B are views similar to Figures 8A and 8B, respectively, illustrating how the penetrating member accelerator returns the penetrating member to its original position;

Figure 10 is a block diagram illustrating functional components of the apparatus; and

Figure 11 is an end view illustrating a cartridge according to an optional embodiment that allows for better adhesion of sterilization barriers.

15 Figure 12 is a cross-sectional view of an embodiment having features of the invention.

Figure 13 is a cross-sectional view of an embodiment having features of the invention in operation.

Figure 14 is a cross-sectional view illustrating a low-friction coating applied to one penetrating member contact surface.

20 Figure 15 is a cross-sectional view illustrating a coating applied to one penetrating member contact surface which increases friction and improves the microscopic contact area between the penetrating member and the penetrating member contact surface.

Figure 16 illustrates a portion of a penetrating member cartridge having an annular configuration with a plurality of radially oriented penetrating member slots and a distal edge of a drive member disposed in one of the penetrating member slots.

25 Figure 17 is an elevational view in partial longitudinal section of a coated penetrating member in contact with a coated penetrating member contact surface.

Figure 18 illustrates an embodiment of a lancing device having features of the invention.

30 Figure 19 is a perspective view of a portion of a penetrating member cartridge base plate having a plurality of penetrating member slots and drive member guide slots disposed radially inward of and aligned with the penetrating member slots.

Figures 20-22 illustrate a penetrating member cartridge in section, a drive member, a penetrating member and the tip of a patient's finger during three sequential phases of a lancing cycle.

Figure 23 illustrates an embodiment of a penetrating member cartridge having features of
5 the invention.

Figure 24 is an exploded view of a portion of the penetrating member cartridge of Figure 12.

Figures 25 and 26 illustrate a multiple layer sterility barrier disposed over a penetrating member slot being penetrated by the distal end of a penetrating member during a lancing cycle.

10 Figures 27 and 28 illustrate an embodiment of a drive member coupled to a driver wherein the drive member includes a cutting member having a sharpened edge which is configured to cut through a sterility barrier of a penetrating member slot during a lancing cycle in order for the drive member to make contact with the penetrating member.

Figures 29 and 30 illustrate an embodiment of a penetrating member slot in longitudinal
15 section having a ramped portion disposed at a distal end of the penetrating member slot and a drive member with a cutting edge at a distal end thereof for cutting through a sterility barrier during a lancing cycle.

Figures 31-34 illustrate drive member slots in a penetrating member cartridge wherein at
20 least a portion of the drive member slots have a tapered opening which is larger in transverse dimension at the top of the drive member slot than at the bottom of the drive member slot.

Figures 35-37 illustrate an embodiment of a penetrating member cartridge and penetrating member drive member wherein the penetrating member drive member has a contoured jaws configured to grip a penetrating member shaft.

Figures 38 and 39 show a portion of a lancing device having a lid that can be opened to
25 expose a penetrating member cartridge cavity for removal of a used penetrating member cartridge and insertion of a new penetrating member cartridge.

Figures 40 and 41 illustrate a penetrating member cartridge that has penetrating member slots on both sides.

Figures 42-44 illustrate end and perspective views of a penetrating member cartridge
30 having a plurality of penetrating member slots formed from a corrugated surface of the penetrating member cartridge.

Figures 45-48 illustrate embodiments of a penetrating member and drive member wherein the penetrating member has a slotted shaft and the drive member has a protuberance configured to mate with the slot in the penetrating member shaft.

Figure 49 is a perspective view of a cartridge according to the present invention.

5 Figures 50 and 51 show close-ups of outer peripheries various cartridges.

Figure 52 is a perspective view of an underside of a cartridge.

Figure 53A shows a top down view of a cartridge and the punch and pusher devices.

Figure 53B is a perspective view of one embodiment of a punch plate.

10 Figures 54A-54G show a sequence of motion for the punch plate, the cartridge, and the cartridge pusher.

Figures 55A-55B show cross-sections of the system according to the present invention.

Figure 56A shows a perspective view of the system according to the present invention.

Figures 56B-56D are cut-away views showing mechanisms within the present invention.

Figures 57-65B show optional embodiments according to the present invention.

15 Figure 66-68 shows a still further embodiment of a cartridge according to the present invention.

Figures 69A-69L show the sequence of motions associated with an optional embodiment of a cartridge according to the present invention.

20 Figure 70-72 show views of a sample modules used with still further embodiments of a cartridge according to the present invention.

Figure 73 shows a cartridge with a sterility barrier and a analyte detecting member layer.

Figure 74-78 show still further embodiments of analyte detecting members coupled to a cartridge.

25 Figures 79-84 show optional configurations for a cartridge for use with the present invention.

Figure 85 shows a see-through view of one embodiment of a system according to the present invention.

Figure 86 is a schematic of an optional embodiment of a system according to the present invention.

30 Figures 87A-87B show still further embodiments of cartridges according to the present invention.

Figure 88 shows a cartridge having an array of analyte detecting members.

Figures 89-90 show embodiments of illumination systems for use with the present invention.

DESCRIPTION OF THE SPECIFIC EMBODIMENTS

5 The present invention provides a multiple analyte detecting member solution for body fluid sampling. Specifically, some embodiments of the present invention provides a multiple analyte detecting member and multiple lancet solution to measuring analyte levels in the body. The invention may use a high density design. It may use lancets of smaller size than known lancets. The device may be used for multiple lancing events without having to remove a
10 disposable from the device. The invention may provide improved sensing capabilities. At least some of these and other objectives described herein will be met by embodiments of the present invention.

It is to be understood that both the foregoing general description and the following detailed description are exemplary and explanatory only and are not restrictive of the invention,
15 as claimed. It must be noted that, as used in the specification and the appended claims, the singular forms “a”, “an” and “the” include plural referents unless the context clearly dictates otherwise. Thus, for example, reference to “a material” may include mixtures of materials, reference to “a chamber” may include multiple chambers, and the like. References cited herein are hereby incorporated by reference in their entirety, except to the extent that they conflict with
20 teachings explicitly set forth in this specification.

In this specification and in the claims which follow, reference will be made to a number of terms which shall be defined to have the following meanings:

“Optional” or “optionally” means that the subsequently described circumstance may or may not occur, so that the description includes instances where the circumstance occurs and
25 instances where it does not. For example, if a device optionally contains a feature for analyzing a blood sample, this means that the analysis feature may or may not be present, and, thus, the description includes structures wherein a device possesses the analysis feature and structures wherein the analysis feature is not present.

“Analyte detecting member” refers to any use, singly or in combination, of chemical test
30 reagents and methods, electrical test circuits and methods, physical test components and methods, optical test components and methods, and biological test reagents and methods to yield information about a blood sample. Such methods are well known in the art and may be based on teachings of, e.g. Tietz Textbook of Clinical Chemistry, 3d Ed., Sec. V, pp. 776-78 (Burtis &

Ashwood, Eds., W.B. Saunders Company, Philadelphia, 1999); U.S. Pat. No. 5,997,817 to Chrismore et al. (Dec. 7, 1999); U.S. Pat. No. 5,059,394 to Phillips et al. (Oct. 22, 1991); U.S. Pat. No. 5,001,054 to Wagner et al. (Mar. 19, 1991); and U.S. Pat. No. 4,392,933 to Nakamura et al. (July 12, 1983), the teachings of which are hereby incorporated by reference, as well as
5 others. Analyte detecting member may include tests in the sample test chamber that test electrochemical properties of the blood, or they may include optical means for sensing optical properties of the blood (e.g. oxygen saturation level), or they may include biochemical reagents (e.g. antibodies) to sense properties (e.g. presence of antigens) of the blood. The analyte detecting member may comprise biosensing or reagent material that will react with an analyte in
10 blood (e.g. glucose) or other body fluid so that an appropriate signal correlating with the presence of the analyte is generated and can be read by the reader apparatus. By way of example and not limitation, analyte detecting member may “associated with”, “mounted within”, or “coupled to” a chamber or other structure when the analyte detecting member participates in the function of providing an appropriate signal about the blood sample to the reader device. Analyte
15 detecting member may also include nanowire analyte detecting members as described herein. Analyte detecting member may use potentiometric, coulometric, or other method useful for detection of analyte levels.

Figures 1-11 of the accompanying drawings illustrates one embodiment of a system 10 for piercing skin to obtain a blood sample. The system 10 may include a replaceable cartridge 12
20 and an apparatus 14 for removably receiving the cartridge 12 and for manipulating components of the cartridge 12.

Referring jointly to Figures 1 and 2, the cartridge 12 may include a plurality of penetrating members 18. The cartridge 12 may be in the form of a circular disc and has an outer circular surface 20 and an opening forming an inner circular surface 22. A plurality of grooves
25 24 are formed in a planar surface 26 of the cartridge 12. Each groove 24 is elongated and extends radially out from a center point of the cartridge 12. Each groove 24 is formed through the outer circular surface 20. Although not shown, it should be understood that the grooves 24 are formed over the entire circumference of the planar surface 26. As shown in Figures 3 and 4, each groove 24 is relatively narrow closer to the center point of the cartridge 12 and slightly
30 wider further from the center point. These grooves 24 may be molded into the cartridge 12, machined into the cartridge, or formed using other methods useful in the manufacture of medical devices.

In the present embodiment, each penetrating member 18 has an elongated body 26 and a sharpened distal end 27 having a sharp tip 30. The penetrating member 18 may have a circular in cross-section with a diameter in this embodiment of about 0.315 mm. All outer surfaces of the penetrating member 18 may have the same coefficient of friction. The penetrating member may be , but is not necessarily, a bare lancet. The lancet is "bare", in the sense that no raised formations or molded parts are formed thereon that are complementarily engageable with another structure. Traditional lancets include large plastic molded parts that are used to facilitate engagement. Unfortunately, such attachments add size and cost. In the most basic sense, a bare lancet or bare penetrating member is an elongate wire having sharpened end. If it is of sufficiently small diameter, the tip may be penetrating without having to be sharpened. A bare lancet may be bent and still be considered a bare lancet. The bare lancet in one embodiment may be made of one material.

In the present embodiment, each penetrating member 18 is located in a respective one of the grooves 24. The penetrating members 18 have their sharpened distal ends 27 pointed radially out from the center point of the cartridge 12. A proximal end of each penetrating member 15 may engage in an interference fit with opposing sides of a respective groove 24 as shown in Figure 3. Other embodiments of the cartridge 12 may not use such an interference fit. For example, they may use a fracturable adhesive to releasably secure the penetrating member 18 to the cartridge 12. As shown in Figure 4, more distal portions of the penetrating member 18 are not engaged with the opposing sides of the groove 24 due to the larger spacing between the sides.

The cartridge 12 may further include a sterilization barrier 28 attached to the upper surface 26. The sterilization barrier 28 is located over the penetrating members 18 and serves to insulate the penetrating members 18 from external contaminants. The sterilization barrier 28 is made of a material that can easily be broken when an edge of a device applies a force thereto. The sterilization barrier 28 alone or in combination with other barriers may be used to create a sterile environment about at least the tip of the penetrating member prior to lancing or actuation. The sterilization barrier 28 may be made of a variety of materials such as but not limited to metallic foil, aluminum foil, paper, polymeric material, or laminates combining any of the above. Other details of the sterilization barrier are detailed herein.

In the present embodiment, the apparatus 14 may include a housing 30, an initiator button 32, a penetrating member movement subassembly 34, a cartridge advance subassembly 36, batteries 38, a capacitor 40, a microprocessor controller 42, and switches 44. The housing 30 may have a lower portion 46 and a lid 48. The lid 48 is secured to the lower portion 46 with a

hinge 50. The lower portion 46 may have a recess 52. A circular opening 54 in the lower portion 46 defines an outer boundary of the recess 52 and a level platform 56 of the lower portion 46 defines a base of the recess 52.

In use, the lid 48 of the present embodiment is pivoted into a position as shown in Figure 5. The cartridge 12 is flipped over and positioned in the recess 52. The planar surface 26 rests against the level platform 56 and the circular opening 54 contacts the outer circular surface 20 to prevent movement of the cartridge 12 in a plane thereof. The lid 48 is then pivoted in a direction 60 and closes the cartridge 12.

Referring to the embodiment shown in Figure 5, the penetrating member movement subassembly 34 includes a lever 62, a penetrating member accelerator 64, a linear actuator 66, and a spring 68. Other suitable actuators including but not limited to rotary actuators are described in commonly assigned, copending U.S. Patent Application Ser. No. 10/127,395 (Attorney Docket No. 38187-2551) filed April 19, 2002. The lever 62 may be pivotably secured to the lower portion 46. The button 32 is located in an accessible position external of the lower portion 46 and is connected by a shaft 70 through the lower portion 46 to one end of the lever 62. The penetrating member accelerator 64 is mounted to an opposing end of the lever 62. A user depresses the button 32 in an upward direction 66 so that the shaft 70 pivots the end of the lever 62 to which it is connected in an upward direction. The opposing end of the lever pivots in a downward direction 66. The spring 46 is positioned between the button 32 and the base 40 and compresses when the button 32 is depressed to create a force that tends to move the button 32 down and pivot the penetrating member accelerator upward in a direction opposite to the direction 64.

Referring to Figures 6A and 6B in this particular embodiment, the movement of the button into the position shown in Figure 5 also causes contact between a terminal 74 on the shaft 20 with a terminal 70 secured to the lower portion 46. Contact between the terminals 74 and 76 indicates that the button 32 has been fully depressed. With the button 32 depressed, the cartridge 12 can be rotated without interference by the penetrating member actuator 64. To this effect, the cartridge advancer subsystem 36 includes a pinion gear 80 and a stepper motor 82. The stepper motor 82 is secured to the lower portion 46. The pinion gear 80 is secured to the stepper motor 82 and is rotated by the stepper motor 82. Teeth on the pinion gear 80 engage with teeth on the inner circular surface 22 of the cartridge 12. Rotation of the pinion gear 80 causes rotation of the cartridge 12 about the center point thereof. Each time that the terminals 74 and 76 make contact, the stepper motor 82 is operated to rotate the cartridge 12 through a discrete angle equal to an

angular spacing from a centerline of one of the penetrating members 18 to a centerline of an adjacent penetrating member. A select penetrating member 18 is so moved over the penetrating member accelerator 64, as shown in Figure 6B. Subsequent depressions of the button 32 will cause rotation of subsequent adjacent penetrating members 18 into a position over the
5 penetrating member accelerator 64.

The user then releases pressure from the button, as shown in Figure 7A. The force created by the spring 68 or other resilient member moves the button 32 in a downward direction 76. The shaft 70 is pivotably secured to the lever 62 so that the shaft 70 moves the end of the lever 62 to which it is connected down. The opposite end of the lever 62 pivots the penetrating
10 member accelerator 64 upward in a direction 80. As shown in Figure 7B, an edge 82 of the penetrating member accelerator 64 breaks through a portion of the sterilization barrier 28 and comes in to physical contact with a lower side surface of the penetrating member 18.

Referring to Figure 8A, the linear actuator 66 includes separate advancing coils 86A and retracting coils 86B, and a magnetizable slug 90 within the coils 86A and 86B. The coils 86A
15 and 86B are secured to the lower portion of 46, and the slug 90 can move within the coils 86A and 88B. Once the penetrating member accelerator 64 is located in the position shown in Figures 7A and 7B, electric current is provided to the advancing coils 86 only. The current in the advancing coils 86 creates a force in a direction 88 on the slug 90 according to conventional principles relating to electromagnetics.

A bearing 91 is secured to the lever and the penetrating member accelerator 64 has a slot
20 92 over the bearing 91. The slot 92 allows for the movement of the penetrating member accelerator 64 in the direction 88 relative to the lever 62, so that the force created on the slug moves the penetrating member accelerator 64 in the direction 88.

The spring 68 is not entirely relaxed, so that the spring 68, through the lever 62, biases
25 the penetrating member accelerator 64 against the lower side surface of the penetrating member 18 with a force F1. The penetrating member 18 rests against a base 88 of the cartridge 12. An equal and opposing force F2 is created by the base 88 on an upper side surface of the penetrating member 18.

The edge 82 of the penetrating member accelerator 64 has a much higher coefficient of
30 friction than the base 88 of the cartridge 12. The higher coefficient of friction of the edge contributes to a relatively high friction force F3 on the lower side surface of the penetrating member 18. The relatively low coefficient of friction of the base 88 creates a relatively small friction force F4 on the upper side surface of the penetrating member 18. A difference between

the force F3 and F4 is a resultant force that accelerates the penetrating member in the direction 88 relative to the cartridge 12. The penetrating member is moved out of the interference fit illustrated in Figure 3. The bare penetrating member 18 is moved without the need for any engagement formations on the penetrating member. Current devices, in contrast, often make use
5 a plastic body molded onto each penetrating member to aid in manipulating the penetrating members. Movement of the penetrating member 18 moves the sharpened end thereof through an opening 90 in a side of the lower portion 46. The sharp end 30 of the penetrating member 18 is thereby moved from a retracted and safe position within the lower portion 46 into a position wherein it extends out of the opening 90. Accelerated, high-speed movement of the penetrating
10 member is used so that the sharp tip 30 penetrates skin of a person. A blood sample can then be taken from the person, typically for diabetic analysis.

Reference is now made to Figures 9A and 9B. After the penetrating member is accelerated (for example, but not limitation, less than .25 seconds thereafter), the current to the accelerating coils 86A is turned off and the current is provided to the retracting coils 86B. The
15 slug 90 moves in an opposite direction 92 together with the penetrating member accelerator 64. The penetrating member accelerator 64 then returns the used penetrating member into its original position, i.e., the same as shown in Figure 7B.

Subsequent depression of the button as shown in Figure 5 will then cause one repetition of the process described, but with an adjacent sterile penetrating member. Subsequent sterile
20 penetrating members can so be used until all the penetrating members have been used, i.e., after one complete revolution of the cartridge 12. In this embodiment, a second revolution of the cartridge 12 is disallowed to prevent the use of penetrating members that have been used in a previous revolution and have become contaminated. The only way in which the user can
25 continue to use the apparatus 14 is by opening the lid 48 as shown in Figure 1, removing the used cartridge 12, and replacing the used cartridge with another cartridge. A analyte detecting member (not shown) detects whenever a cartridge is removed and replaced with another cartridge. Such a analyte detecting member may be but is not limited to an optical analyte detecting member, an electrical contact analyte detecting member, a bar code reader, or the like.

Figure 10 illustrates the manner in which the electrical components may be functionally
30 interconnected for the present embodiment. The battery 38 provides power to the capacitor 40 and the controller 42. The terminal 76 is connected to the controller 42 so that the controller recognizes when the button 32 is depressed. The capacitor to provide power (electric potential and current) individually through the switches (such as field-effect transistors) to the advancing

coils 86A, retracting coils 86B and the stepper motor 82. The switches 44A, B, and C are all under the control of the controller 42. A memory 100 is connected to the controller. A set of instructions is stored in the memory 100 and is readable by the controller 42. Further functioning of the controller 42 in combination with the terminal 76 and the switches 44A, B, and C should be evident from the foregoing description.

Figure 11 illustrates a configuration for another embodiment of a cartridge having penetrating members. The cartridge 112 has a corrugated configuration and a plurality of penetrating members 118 in grooves 124 formed in opposing sides of the cartridge 112. Sterilization barriers 126 and 128 are attached over the penetrating members 118 at the top and the penetrating members 118 at the bottom, respectively. Such an arrangement provides large surfaces for attachment of the sterilization barriers 126 and 128. All the penetrating members 118 on the one side are used first, whereafter the cartridge 112 is turned over and the penetrating members 118 on the other side are used. Additional aspects of such a cartridge are also discussed in Figures 42-44.

Referring now to Figures 12-13, a friction based method of coupling with and driving bare lancets or bare penetrating members will be described in further detail. Any embodiment of the present invention disclosed herein may be adapted to use these methods. As seen in Figure 12, surface 201 is physically in contact with penetrating member 202. Surface 203 is also physically in contact with penetrating member 202. In the present embodiment of the invention, surface 201 is stainless steel, penetrating member 202 is stainless steel, and surface 203 is polytetrafluoroethylene-coated stainless steel.

Figure 13 illustrates one embodiment of the friction based coupling in use. Normal force 206 may be applied vertically to surface 201, pressing it against penetrating member 202. Penetrating member 202 is thereby pressed against surface 203. Normal force 206 is transmitted through surface 201 and penetrating member 202 to also act between penetrating member 202 and surface 203. Surface 203 is held rigid or stationary with respect to a target of the lancet. Using the classical static friction model, the maximum frictional force between surface 201 and penetrating member 202 is equal to the friction coefficient between surface 201 and penetrating member 202 multiplied by the normal force between surface 201 and penetrating member 202. In this embodiment, the maximum frictional force between surface 203 and penetrating member 202 is equal to the coefficient of friction between the surface 203 and the penetrating member 202 multiplied by the normal force between the surface 203 and the penetrating member 202. Because friction coefficient between surface 203 and penetrating member 202 is less than

friction coefficient between surface 201 and penetrating member 202, the interface between surface 201 and penetrating member 202 can develop a higher maximum static friction force than can the interface between surface 203 and penetrating member 202.

Driving force as indicated by arrow 207 is applied to surface 201 perpendicular to normal force 206. The sum of the forces acting horizontally on surface 201 is the sum of driving force 207 and the friction force developed at the interface of surface 201 and penetrating member 202, which acts in opposition to driving force 207. Since the coefficient of friction between surface 203 and penetrating member 202 is less than the coefficient of friction between surface 201 and penetrating member 202, penetrating member 202 and surface 201 will remain stationary with respect to each other and can be considered to behave as one piece when driving force 207 just exceeds the maximum frictional force that can be supported by the interface between surface 203 and penetrating member 202. Surface 201 and penetrating member 202 can be considered one piece because the coefficient of friction between surface 201 and penetrating member 202 is high enough to prevent relative motion between the two.

In one embodiment, the coefficient of friction between surface 201 and penetrating member 202 is approximately 0.8 corresponding to the coefficient of friction between two surfaces of stainless steel, while the coefficient of friction between surface 203 and penetrating member 202 is approximately 0.04, corresponding to the coefficient of friction between a surface of stainless steel and one of polytetrafluoroethylene. Normal force 206 has a value of 202 Newtons. Using these values, the maximum frictional force that the interface between surface 201 and penetrating member 202 can support is 1.6 Newtons, while the maximum frictional force that the interface between surface 203 and penetrating member 202 can support is 0.08 Newtons. If driving force 207 exceeds 0.08 Newtons, surface 201 and penetrating member 202 will begin to accelerate together with respect to surface 203. Likewise, if driving force 207 exceeds 1.6 Newtons and penetrating member 202 encounters a rigid barrier, surface 201 would move relative to penetrating member 202.

Another condition, for example, for surface 201 to move relative to penetrating member 202 would be in the case of extreme acceleration. In an embodiment, penetrating member 202 has a mass of 8.24×10^{-6} kg. An acceleration of $194,174 \text{ m/s}^2$ of penetrating member 202 would therefore be required to exceed the frictional force between penetrating member 202 and surface 201, corresponding to approximately 19,800 g's. Without being bound to any particular embodiment or theory of operation, other methods of applying friction base coupling may also

be used. For example, the penetrating member 202 may be engaged by a coupler using a interference fit to create the frictional engagement with the member.

Figure 14 illustrates a polytetrafluoroethylene coating on stainless steel surface 203 in detail. It should be understood that the surface 203 may be coated with other materials such as but not limited to Telfon®, silicon, polymer or glass. The coating may cover all of the
5 penetrating member, only the proximal portions, only the distal portions, only the tip, only some other portion, or some combination of some or all of the above. Figure 15 illustrates a doping of lead applied to surface 201, which conforms to penetrating member 202 microscopically when pressed against it. Both of these embodiments and other coated embodiments of a penetrating
10 member may be used with the actuation methods described herein.

The shapes and configurations of surface 201 and surface 102 could be some form other than shown in Figures 12-15. For example, surface 201 could be the surface of a wheel, which when rotated causes penetrating member 202 to advance or retract relative to surface 203. Surface 201 could be coated with another conformable material besides lead, such as a plastic. It
15 could also be coated with particles, such as diamond dust, or given a surface texture to enhance the friction coefficient of surface 201 with penetrating member 202. Surface 202 could be made of or coated with diamond, fluorinated ethylene propylene, perfluoroalkoxy, a copolymer of ethylene and tetrafluoroethylene, a copolymer of ethylene and chlorotrifluoroethylene, or any other material with a coefficient of friction with penetrating member 202 lower than that of the
20 material used for surface 201.

Referring to Figure 16, a portion of a base plate 210 of an embodiment of a penetrating member cartridge is shown with a plurality of penetrating member slots 212 disposed in a radial direction cut into a top surface 214 of the base plate. A drive member 216 is shown with a distal edge 218 disposed within one of the penetrating member slots 212 of the base plate 210. The
25 distal edge 218 of the drive member 216 is configured to slide within the penetrating member slots 212 with a minimum of friction but with a close fit to minimize lateral movement during a lancing cycle.

Figure 17 shows a distal portion 220 of a coated penetrating member 222 in partial longitudinal section. The coated penetrating member 222 has a core portion 224, a coating 226
30 and a tapered distal end portion 228. A portion of a coated drive member 230 is shown having a coating 234 with penetrating member contact surface 236. The penetrating member contact surface 236 forms an interface 238 with an outer surface 240 of the coated penetrating member 222. The interface 238 has a characteristic friction coefficient that will depend in part on the

choice of materials for the penetrating member coating 226 and the drive member coating 234. If silver is used as the penetrating member and drive member coating 226 and 236, this yields a friction coefficient of about 1.3 to about 1.5. Other materials can be used for coatings 226 and 236 to achieve the desired friction coefficient. For example, gold, platinum, stainless steel and other materials may be used for coatings 226 and 236. It may be desirable to use combinations of different materials for coatings 226 and 236. For example, an embodiment may include silver for a penetrating member coating 226 and gold for a drive member coating. Some embodiments of the interface 238 can have friction coefficients of about 1.15 to about 5.0, specifically, about 1.3 to about 2.0.

Embodiments of the penetrating member 222 can have an outer transverse dimension or diameter of about 200 to about 400 microns, specifically, about 275 to about 325 microns. Embodiments of penetrating member 222 can have a length of about 10 to about 30 millimeters, specifically, about 15 to about 25 millimeters. Penetrating member 222 can be made from any suitable high strength alloy such as stainless steel or the like.

Figure 18 is a perspective view of a lancing device 242 having features of the invention. A penetrating member cartridge 244 is disposed about a driver 246 that is coupled to a drive member 248 by a coupler rod 250. The penetrating member cartridge 244 has a plurality of penetrating member slots 252 disposed in a radial configuration in a top surface 254 a base plate 256 of the penetrating member cartridge 244. The distal ends 253 of the penetrating member slots 252 are disposed at an outer surface 260 of the base plate 256. A fractureable sterility barrier 258, shown partially cut away, is disposed on the top surface 254 of base plate 256 over the plurality of penetrating member slots 252. The sterility barrier 258 is also disposed over the outer surface 260 of the base plate 256 in order to seal the penetrating member slots from contamination prior to a lancing cycle. A distal portion of a penetrating member 262 is shown extending radially from the penetrating member cartridge 244 in the direction of a patient's finger 264.

Figure 19 illustrates a portion of the base plate 256 used with the lancing device 242 in more detail and without sterility barrier 258 in place (for ease of illustration). The base plate 256 includes a plurality of penetrating member slots 252 which are in radial alignment with corresponding drive member slots 266. The drive member slots 266 have an optional tapered input configuration that may facilitate alignment of the drive member 248 during downward movement into the drive member slot 266 and penetrating member slot 252. Penetrating member slots 252 are sized and configured to accept a penetrating member 262 disposed therein

and allow axial movement of the penetrating member 262 within the penetrating member slots 252 without substantial lateral movement.

Referring again to Figure 18, in use, the present embodiment of penetrating member cartridge 242 is placed in an operational configuration with the driver 246. A lancing cycle is initiated and the drive member 248 is brought down through the sterility barrier 258 and into a penetrating member slot 252. A penetrating member contact surface of the drive member then makes contact with an outside surface of the penetrating member 262 and is driven distally toward the patient's finger 264 as described above with regard to the embodiment discussed in Figure 20. The friction coefficient between the penetrating member contact surface of the drive member 248 and the penetrating member 262 is greater than the friction coefficient between the penetrating member 262 and an interior surface of the penetrating member slots 252. As such, the drive member 248 is able to drive the penetrating member 262 distally through the sterility barrier 258 and into the patient's finger 264 without any relative movement or substantial relative movement between the drive member 248 and the penetrating member 262.

Referring to Figures 20-22, a lancing cycle sequence is shown for a lancing device 242 with another embodiment of a penetrating member cartridge 244 as shown in Figures 23 and 24. The base plate 256 of the penetrating member cartridge 242 shown in Figures 23 and 24 has a plurality of penetrating member slots 252 with top openings 268 that do not extend radially to the outer surface 260 of the base plate 256. In this way, the penetrating member slots 252 can be sealed with a first sterility barrier 270 disposed on the top surface 254 of the base plate 256 and a second sterility barrier 272 disposed on the outer surface 260 of the base plate 256. Penetrating member outlet ports 274 are disposed at the distal ends of the penetrating member slots 252.

Referring again to Figure 20, the penetrating member 262 is shown in the proximally retracted starting position within the penetrating member slot 252. The outer surface of the penetrating member 276 is in contact with the penetrating member contact surface 278 of the drive member 248. The friction coefficient between the penetrating member contact surface 278 of the drive member 248 and the outer surface 276 of the penetrating member 262 is greater than the friction coefficient between the penetrating member 262 and an interior surface 280 of the penetrating member slots 252. A distal drive force as indicated by arrow 282 in Figure 10 is then applied via the drive coupler 250 to the drive member 248 and the penetrating member is driven out of the penetrating member outlet port 274 and into the patient's finger 264. A proximal retraction force, as indicated by arrow 284 in Figure 22, is then applied to the drive member 248

and the penetrating member 262 is withdrawn from the patient's finger 264 and back into the penetrating member slot 252.

Figures 25 and 26 illustrate an embodiment of a multiple layer sterility barrier 258 in the process of being penetrated by a penetrating member 62. It should be understood that this barrier 258 may be adapted for use with any embodiment of the present invention. The sterility barrier 258 shown in Figures 25 and 26 is a two layer sterility barrier 258 that facilitates maintaining sterility of the penetrating member 262 as it passes through and exits the sterility barrier 258. In Figure 25, the distal end 286 of the penetrating member 262 is applying an axial force in a distal direction against an inside surface 288 of a first layer 290 of the sterility barrier 258, so as to deform the first layer 290 of the sterility barrier 258. The deformation 291 of the first layer 290 in turn applies a distorting force to the second layer 292 of the sterility barrier 258. The second layer of the sterility barrier is configured to have a lower tensile strength than the first layer 290. As such, the second layer 292 fails prior to the first layer 290 due to the strain imposed on the first layer 290 by the distal end 286 of the penetrating member 262, as shown in Figure 26. After the second layer 292 fails, it then retracts from the deformed portion 291 of the first layer 290 as shown by arrows 294 in Figure 26. As long as the inside surface 288 and outside surface 296 of the first layer 290 are sterile prior to failure of the second layer 292, the penetrating member 262 will remain sterile as it passes through the first layer 290 once the first layer eventually fails. Such a multiple layer sterility barrier 258 can be used for any of the embodiments discussed herein. The multiple layer sterility barrier 258 can also include three or more layers.

Referring to Figures 27 and 28, an embodiment of a drive member 300 coupled to a driver 302 wherein the drive member 300 includes a cutting member 304 having a sharpened edge 306 which is configured to cut through a sterility barrier 258 of a penetrating member slot 252 during a lancing cycle in order for the drive member 300 to make contact with a penetrating member. An optional lock pin 308 on the cutting member 304 can be configured to engage the top surface 310 of the base plate in order to prevent distal movement of the cutting member 304 with the drive member 300 during a lancing cycle.

Figures 29 and 30 illustrate an embodiment of a penetrating member slot 316 in longitudinal section having a ramped portion 318 disposed at a distal end 320 of the penetrating member slot. A drive member 322 is shown partially disposed within the penetrating member slot 316. The drive member 322 has a cutting edge 324 at a distal end 326 thereof for cutting through a sterility barrier 328 during a lancing cycle. Figure 30 illustrates the cutting edge 324

cutting through the sterility barrier 328 during a lancing cycle with the cut sterility barrier 328 peeling away from the cutting edge 324.

Figures 31-34 illustrate drive member slots in a base plate 330 of a penetrating member cartridge wherein at least a portion of the drive member slots have a tapered opening which is larger in transverse dimension at a top surface of the base plate than at the bottom of the drive member slot. Figure 31 illustrates a base plate 330 with a penetrating member slot 332 that is tapered at the input 334 at the top surface 336 of the base plate 330 along the entire length of the penetrating member slot 332. In such a configuration, the penetrating member slot and drive member slot (not shown) would be in communication and continuous along the entire length of the slot 332. As an optional alternative, a base plate 338 as shown in Figure 32 and 33 can have a drive member slot 340 that is axially separated from the corresponding penetrating member slot 342. With this configuration, the drive member slot 340 can have a tapered configuration and the penetrating member slot 342 can have a straight walled configuration. In addition, this configuration can be used for corrugated embodiments of base plates 346 as shown in Figure 34. In Figure 34, a drive member 348 is disposed within a drive member slot 350. A penetrating member contact surface 352 is disposed on the drive member 348. The contact surface 352 has a tapered configuration that will facilitate lateral alignment of the drive member 348 with the drive member slot 350.

Figures 35-37 illustrate an embodiment of a penetrating member cartridge 360 and drive member 362 wherein the drive member 362 has contoured jaws 364 configured to grip a penetrating member shaft 366. In Figure 35, the drive member 362 and penetrating member shaft 366 are shown in transverse cross section with the contoured jaws 364 disposed about the penetrating member shaft 366. A pivot point 368 is disposed between the contoured jaws 364 and a tapered compression slot 370 in the drive member 362. A compression wedge 372 is shown disposed within the tapered compression slot 370. Insertion of the compression wedge 372 into the compression slot 370 as indicated by arrow 374, forces the contoured jaws 364 to close about and grip the penetrating member shaft 366 as indicated by arrows 376.

Figure 36 shows the drive member 362 in position about a penetrating member shaft 366 in a penetrating member slot 378 in the penetrating member cartridge 360. The drive member can be actuated by the methods discussed above with regard to other drive member and driver embodiments. Figure 37 is an elevational view in longitudinal section of the penetrating member shaft 166 disposed within the penetrating member slot 378. The arrows 380 and 382 indicate in a general way, the path followed by the drive member 362 during a lancing cycle. During a

lancing cycle, the drive member comes down into the penetrating member slot 378 as indicated by arrow 380 through an optional sterility barrier (not shown). The contoured jaws of the drive member then clamp about the penetrating member shaft 366 and move forward in a distal direction so as to drive the penetrating member into the skin of a patient as indicated by arrow 382.

Figures 38 and 39 show a portion of a lancing device 390 having a lid 392 that can be opened to expose a penetrating member cartridge cavity 394 for removal of a used penetrating member cartridge 396 and insertion of a new penetrating member cartridge 398. Depression of button 400 in the direction indicated by arrow 402 raises the drive member 404 from the surface of the penetrating member cartridge 396 by virtue of lever action about pivot point 406. Raising the lid 392 actuates the lever arm 408 in the direction indicated by arrow 410 which in turn applies a tensile force to cable 412 in the direction indicated by arrow 414. This action pulls the drive member back away from the penetrating member cartridge 396 so that the penetrating member cartridge 396 can be removed from the lancing device 390. A new penetrating member cartridge 398 can then be inserted into the lancing device 390 and the steps above reversed in order to position the drive member 404 above the penetrating member cartridge 398 in an operational position.

Figures 40 and 41 illustrate a penetrating member cartridge 420 that has penetrating member slots 422 on a top side 424 and a bottom side 426 of the penetrating member cartridge 420. This allows for a penetrating member cartridge 420 of a diameter D to store for use twice the number of penetrating members as a one sided penetrating member cartridge of the same diameter D.

Figures 42-44 illustrate end and perspective views of a penetrating member cartridge 430 having a plurality of penetrating member slots 432 formed from a corrugated surface 434 of the penetrating member cartridge 430. Penetrating members 436 are disposed on both sides of the penetrating member cartridge 430. A sterility barrier 438 is shown disposed over the penetrating member slots 432 in Figure 44.

Figures 45-48 illustrate embodiments of a penetrating member 440 and drive member 442 wherein the penetrating member 440 has a transverse slot 444 in the penetrating member shaft 446 and the drive member 442 has a protuberance 448 configured to mate with the transverse slot 444 in the penetrating member shaft 446. Figure 45 shows a protuberance 448 having a tapered configuration that matches a tapered configuration of the transverse slot 444 in the penetrating member shaft 446. Figure 46 illustrates an optional alternative embodiment

wherein the protuberance 448 has straight walled sides that are configured to match the straight walled sides of the transverse slot 444 shown in Figure 46. Figure 47 shows a tapered protuberance 448 that is configured to leave an end gap 450 between an end of the protuberance 448 and a bottom of the transverse slot in the penetrating member shaft 446.

5 Figure 48 illustrates a mechanism 452 to lock the drive member 442 to the penetrating member shaft 446 that has a lever arm 454 with an optional bearing 456 on the first end 458 thereof disposed within a guide slot 459 of the drive member 442. The lever arm 454 has a pivot point 460 disposed between the first end 458 of the lever arm 454 and the second end 462 of the lever arm 454. A biasing force is disposed on the second end 462 of the lever arm 454 by a
10 spring member 464 that is disposed between the second end 462 of the lever arm 454 and a base plate 466. The biasing force in the direction indicated by arrow 468 forces the penetrating member contact surface 470 of the drive member 442 against the outside surface of the penetrating member 446 and, in addition, forces the protuberance 448 of the drive member 442 into the transverse slot 444 of the penetrating member shaft 446.

15 Referring now to Figure 49, another embodiment of a replaceable cartridge 500 suitable for housing a plurality of individually moveable penetrating members (not shown) will be described in further detail. Although cartridge 500 is shown with a chamfered outer periphery, it should also be understood that less chamfered and unchamfered embodiments of the cartridge 500 may also be adapted for use with any embodiment of the present invention disclosed herein.
20 The penetrating members slidably coupled to the cartridge may be a bare lancet or bare elongate member without outer molded part or body pieces as seen in conventional lancet. The bare design reduces cost and simplifies manufacturing of penetrating members for use with the present invention. The penetrating members may be retractable and held within the cartridge so that they are not able to be used again. The cartridge is replaceable with a new cartridge once all
25 the piercing members have been used. The lancets or penetrating members may be fully contained in the used cartridge so as to minimize the chance of patient contact with such waste.

As can be seen in Figure 49, the cartridge 500 may include a plurality of cavities 501 for housing a penetrating member. In this embodiment, the cavity 501 may have a longitudinal opening 502 associated with the cavity. The cavity 501 may also have a lateral opening 503
30 allowing the penetrating member to exit radially outward from the cartridge. As seen in Figure 49, the outer radial portion of the cavity may be narrowed. The upper portion of this narrowed area may also be sealed or swaged to close the top portion 505 and define an enclosed opening 506 as shown in Figure 50. Optionally, the narrowed area 504 may retain an open top

configuration, though in some embodiments, the foil over the gap is unbroken, preventing the penetrating member from lifting up or extending upward out of the cartridge. The narrowed portion 504 may act as a bearing and/or guide for the penetrating member. Figure 51 shows that the opening 506 may have a variety of shapes such as but not limited to, circular, rectangular, triangular, hexagonal, square, or combinations of any or all of the previous shapes. Openings 507 (shown in phantom) for other microfluidics, capillary tubes, or the like may also be incorporated in the immediate vicinity of the opening 506. In some optional embodiments, such openings 507 may be configured to surround the opening 506 in a concentric or other manner.

Referring now to Figure 52, the underside of a cartridge 500 will be described in further detail. This figure shows many features on one cartridge 500. It should be understood that a cartridge may include some, none, or all of these features, but they are shown in Figure 52 for ease of illustration. The underside may include indentations or holes 510 close to the inner periphery for purpose of properly positioning the cartridge to engage a penetrating member gripper and/or to allow an advancing device (shown in Figure 56B and 56C) to rotate the cartridge 500. Indentations or holes 511 may be formed along various locations on the underside of cartridge 500 and may assume various shapes such as but not limited to, circular, rectangular, triangular, hexagonal, square, or combinations of any or all of the previous shapes. Notches 512 may also be formed along the inner surface of the cartridge 500 to assist in alignment and/or rotation of the cartridge. It should be understood of course that some of these features may also be placed on the topside of the cartridge in areas not occupied by cavities 501 that house the penetrating members. Notches 513 may also be incorporated along the outer periphery of the cartridge. These notches 513 may be used to gather excess material from the sterility barrier 28 (not shown) that may be used to cover the angled portion 514 of the cartridge. In the present embodiment, the cartridge has a flat top surface and an angled surface around the outside.

Welding a foil type sterility barrier over that angled surface, the foil folds because of the change in the surfaces which is now at 45 degrees. This creates excess material. The grooves or notches 513 are there as a location for that excess material. Placing the foil down into those grooves 513 which may tightly stretch the material across the 45 degree angled surface. Although in this embodiment the surface is shown to be at 45 degrees, it should be understood that other angles may also be used. For example, the surface may be at any angle between about 3 degrees to 90 degrees, relative to horizontal. The surface may be squared off. The surface may be unchamfered. The surface may also be a curved surface or it may be combinations of a variety of angled surfaces, curved and straight surfaces, or any combination of some or all of the above.

Referring now to Figures 53-54, the sequence in which the cartridge 500 is indexed and penetrating members are actuated will now be described. It should be understood that some steps described herein may be combined or taken out of order without departing from the spirit of the invention. These sequence of steps provides vertical and horizontal movement used with the present embodiment to load a penetrating member onto the driver.

As previously discussed, each cavity on the cartridge may be individually sealed with a foil cover or other sterile enclosure material to maintain sterility until or just before the time of use. In the present embodiment, penetrating members are released from their sterile environments just prior to actuation and are loaded onto a launcher mechanism for use.

Releasing the penetrating member from the sterile environment prior to launch allows the penetrating member in the present embodiment to be actuated without having to pierce any sterile enclosure material which may dull the tip of the penetrating member or place contaminants on the member as it travels towards a target tissue. A variety of methods may be used accomplish this goal.

Figure 53A shows one embodiment of penetrating member release device, which in this embodiment is a punch plate 520 that is shown in a see-through depiction for ease of illustration. The punch plate 520 may include a first portion 521 for piercing sterile material covering the longitudinal opening 502 and a second portion 522 for piercing material covering the lateral opening 503. A slot 523 allows the penetrating member gripper to pass through the punch plate 520 and engage a penetrating member housed in the cartridge 500. The second portion 522 of the punch plate down to engage sterility barrier angled at about a 45 degree slope. Of course, the slope of the barrier may be varied. The punch portion 522 first contacts the rear of the front pocket sterility barrier and as it goes down, the cracks runs down each side and the barrier is pressed down to the bottom of the front cavity. The rear edge of the barrier first contacted by the punch portion 522 is broken off and the barrier is pressed down, substantially cleared out of the way. These features may be more clearly seen in Figure 53B. The punch portion 521 may include a blade portion down the centerline. As the punch comes down, that blade may be aligned with the center of the cavity, cutting the sterility barrier into two pieces. The wider part of the punch 521 then pushes down on the barrier so the they align parallel to the sides of the cavity. This creates a complete and clear path for the gripper throughout the longitudinal opening of the cavity. Additionally, as seen in Figure 53B and 54A, a plurality of protrusion 524 are positioned to engage a cam (Figure 55A) which sequences the punching and other vertical

movement of punch plate 520 and cartridge pusher 525. The drive shaft 526 from a force generator (not shown) which is used to actuate the penetrating member 527.

Referring now to Figures 54A-F, the release and loading of the penetrating members are achieved in the following sequence. Figure 54A shows the release and loading mechanism in rest state with a dirty bare penetrating member 527 held in a penetrating member gripper 530. This is the condition of the device between lancing events. When the time comes for the patient to initiate another lancing event, the used penetrating member is cleared and a new penetrating member is loaded, just prior to the actual lancing event. The patient begins the loading of a new penetrating member by operating a setting lever to initiate the process. The setting lever may operate mechanically to rotate a cam (see Figure 55A) that moves the punch plate 520 and cartridge pusher 525. In other embodiments, a stepper motor or other mover such as but not limited to, a pneumatic actuator, hydraulic actuator, or the like are used to drive the loading sequence.

Figure 54B shows one embodiment of penetrating member gripper 530 in more detail. The penetrating member gripper 530 may be in the form of a tuning fork with sharp edges along the inside of the legs contacting the penetrating member. In some embodiments, the penetrating member may be notched, recessed, or otherwise shaped to receive the penetrating member gripper. As the gripper 530 is pushed down on the penetrating member, the legs are spread open elastically to create a frictional grip with the penetrating member such as but not limited to bare elongate wires without attachments molded or otherwise attached thereon. In some embodiments, the penetrating member is made of a homogenous material without any additional attachments that are molded, adhered, glued or otherwise added onto the penetrating member.

In some embodiments, the gripper 530 may cut into the sides of the penetrating member. The penetrating member in one embodiment may be about 300 microns wide. The grooves that form in the side of the penetrating member by the knife edges are on the order of about 5-10 microns deep and are quite small. In this particular embodiment, the knife edges allow the apparatus to use a small insertion force to get the gripper onto the penetrating member, compared to the force to remove the penetrating member from the gripper the longitudinal axis of an elongate penetrating member. Thus, the risk of a penetrating member being detached during actuation are reduced. The gripper 530 may be made of a variety of materials such as, but not limited to high strength carbon steel that is heat treated to increased hardness, ceramic, substrates with diamond coating, composite reinforced plastic, elastomer, polymer, and sintered metals.

Additionally, the steel may be surface treated. The gripper 130 may have high gripping force with low friction drag on solenoid or other driver.

As seen in Figure 54C, the sequence begins with punch plate 520 being pushed down. This results in the opening of the next sterile cavity 532. In some embodiment, this movement of punch plate 520 may also result in the crimping of the dirty penetrating member to prevent it from being used again. This crimping may result from a protrusion on the punch plate bending the penetrating member or pushing the penetrating member into a groove in the cartridge that hold the penetrating member in place through an interference fit. As seen in Figures 53B and 54C, the punch plate 520 has a protrusion or punch shaped to penetrate a longitudinal opening 502 and a lateral opening 503 on the cartridge. The first portion 521 of the punch that opens cavity 532 is shaped to first pierce the sterility barrier and then push, compresses, or otherwise moves sterile enclosure material towards the sides of the longitudinal opening 502. The second portion 522 of the punch pushes down the sterility barrier at lateral opening or penetrating member exit 503 such that the penetrating member does not pierce any materials when it is actuated toward a tissue site.

Referring now to Figure 54D, the cartridge pusher 525 is engaged by the cam 550 (not shown) and begins to push down on the cartridge 500. The punch plate 520 may also travel downward with the cartridge 500 until it is pushed down to its maximum downward position, while the penetrating member gripper 530 remains vertically stationary. This joint downward motion away from the penetrating member gripper 530 will remove the penetrating member from the gripper. The punch plate 520 essentially pushes against the penetrating member with protrusion 534 (Figure 55A), holding the penetrating member with the cartridge, while the cartridge 500 and the punch plate 520 is lowered away from the penetrating member gripper 530 which in this embodiment remains vertically stationary. This causes the stripping of the used penetrating member from the gripper 530 (Figure 45D) as the cartridge moves relative to the gripper.

At this point as seen in Figure 54E, the punch plate 520 retracts upward and the cartridge 500 is pushed fully down, clear of the gripper 530. Now cleared of obstructions and in a rotatable position, the cartridge 500 increments one pocket or cavity in the direction that brings the newly released, sterile penetrating member in cavity 532 into alignment with the penetrating member gripper 530, as seen in Figure 54F. The rotation of the cartridge occurs due to fingers engaging the holes or indentations 533 on the cartridge, as seen in Figure 54A. In some embodiments, these indentations 533 do not pass completely through cartridge 500. In other

embodiments, these indentations are holes passing completely through. The cartridge has a plurality of little indentations 533 on the top surface near the center of the cartridge, along the inside diameter. In the one embodiment, the sterility barrier is cut short so as not to cover these plurality of indentations 533. It should be understood of course that these holes may be located on bottom, side or other accessible surface. These indentations 533 have two purposes. The apparatus may have one or a plurality of locator pins, static pins, or other keying feature that does not move. In this embodiment, the cartridge will only set down into positions where the gripper 530 is gripping the penetrating member. To index the cassette, the cartridge is lifted off those pins or other keyed feature, rotated around, and dropped onto those pins for the next position. The rotating device is through the use of two fingers: one is a static pawl and the other one is a sliding finger. They engage with the holes 533. The fingers are driven by a slider that may be automatically actuated or actuated by the user. This may be occur mechanically or through electric or other powered devices. Halfway through the stroke, a finger may engage and rotate around the cartridge. A more complete description can be found with text associated with Figures 56B-56C.

Referring now to Figure 54G, with the sterile penetrating member in alignment, the cartridge 500 is released as indicated by arrows 540 and brought back into contact with the penetrating member gripper 530. The new penetrating member 541 is inserted into the gripper 530, and the apparatus is ready to fire once again. After launch and in between lancing events for the present embodiment, the bare lancet or penetrating member 541 is held in place by gripper 530, preventing the penetrating member from accidentally protruding or sliding out of the cartridge 500.

It should be understood of course, that variations can be added to the above embodiment without departing from the spirit of the invention. For example, the penetrating member 541 may be placed in a parked position in the cartridge 500 prior to launch. As seen in Figure 55A, the penetrating member is held by a narrowed portion 542 of the cartridge, creating an interference fit which pinches the proximal end of the penetrating member. Friction from the molding or cartridge holds the penetrating member during rest, preventing the penetrating member from sliding back and forth. Of course, other methods of holding the penetrating member may also be used. As seen in Figure 55B prior to launch, the penetrating member gripper 530 may pull the penetrating member 541 out of the portion 542. The penetrating member 541 may remain in this portion until actuated by the solenoid or other force generator coupled to the penetrating member gripper. A cam surface 544 may be used to pull the

penetrating member out of the portion 542. This mechanical cam surface may be coupled to the mechanical slider driven by the patient, which may be considered a separate force generator. Thus, energy from the patient extracts the penetrating member and this reduces the drain on the device's battery if the solenoid or electric driver were to pull out the penetrating member. The penetrating member may be moved forward a small distance (on the order of about 1 mm or less) from its parked position to pull the penetrating member from the rest position gripper. After penetrating tissue, the penetrating member may be returned to the cartridge and eventually placed into the parked position. This may also occur, though not necessarily, through force provided by the patient. In one embodiment, the placing of the lancet into the parked position does not occur until the process for loading a new penetrating member is initiated by the patient. In other embodiments, the pulling out of the parked position occurs in the same motion as the penetrating member actuation. The return into the parked position may also be considered a continuous motion.

Figure 55A also shows one embodiment of the cam and other surfaces used to coordinate the motion of the punch plate 520. For example, cam 550 in this embodiment is circular and engages the protrusions 524 on the punch plate 520 and the cartridge pusher 525. Figure 55A also more clearly shows protrusion 534 which helps to hold the penetrating member in the cartridge 500 while the penetrating member gripper 530 pulls away from the member, relatively speaking. A ratchet surface 552 that rotates with the cam 550 may be used to prevent the cam from rotating backwards. The raising and lower of cartridge 500 and punch plate 50 used to load/unload penetrating members may be mechanically actuated by a variety of cam surfaces, springs, or the like as may be determined by one skilled in the art. Some embodiments may also use electrical or magnetic device to perform the loading, unloading, and release of bare penetrating members. Although the punch plate 520 is shown to be punching downward to displace, remove, or move the foil or other sterile environment enclosure, it should be understood that other methods such as stripping, pulling, tearing, or some combination of one or more of these methods may be used to remove the foil or sterile enclosure. For example, in other embodiments, the punch plate 520 may be located on an underside of the cartridge and punch upward. In other embodiments, the cartridge may remain vertically stationary while other parts such as the penetrating member gripper and punch plate move to load a sterile penetrating member on to the penetrating member gripper.

Figure 55B also shows other features that may be included in the present apparatus. A fire button 560 may be included for the user to actuate the penetrating member. A front end

interface 561 may be included to allow a patient to seat their finger or other target tissue for lancing. The interface 561 may be removable to be cleaned or replaced. A visual display 562 may be included to show device status, lancing performance, error reports, or the like to the patient.

5 Referring now to Figure 56A, a mechanical slider 564 used by the patient to load new penetrating member may also be incorporated on the housing. The slider 564 may also be coupled to activate an LCD or visual display on the lancing apparatus. In addition to providing a source of energy to index the cartridge, the slider 564 may also switch the electronics to start the display. The user may use the display to select the depth of lancing or other feature. The display
10 may go back to sleep again until it is activated again by motion of the slider 564. The underside the housing 566 may also be hinged or otherwise removable to allow the insertion of cartridge 500 into the device. The cartridge 500 may be inserted using technology current used for insertion of a compact disc or other disc into a compact disc player. In one embodiment, there may be a tray which is deployed outward to receive or to remove a cartridge. The tray may be
15 withdrawn into the apparatus where it may be elevated, lowered, or otherwise transported into position for use with the penetrating member driver. In other embodiments, the apparatus may have a slot into which the cartridge is partially inserted at which point a mechanical apparatus will assist in completing insertion of the cartridge and load the cartridge into proper position inside the apparatus. Such device is akin to the type of compact disc player found on
20 automobiles. The insertions/ejection and loading apparatus of these compact disc players uses gears, pulleys, cables, trays, and/or other parts that may be adapted for use with the present invention.

Referring now to Figure 56B, a more detailed view of one embodiment of the slider 564 is provided. In this embodiment, the slider 564 will move initially as indicated by arrow 567.
25 To complete the cycle, the patient will return the slider to its home position or original starting position as indicated by arrow 568. The slider 564 has an arm 569 which moves with the slider to rotate the cam 550 and engage portions 522. The motion of the slider 564 is also mechanically coupled to a finger 570 which engage the indentations 571 on cartridge 500. The finger 570 is synchronized to rotate the cartridge 500 by pulling as indicated by arrow 572 in the
30 same plane as the cartridge. It should be understood that in some embodiments, the finger 570 pushes instead of pulls to rotate the cartridge in the correct direction. The finger 570 may also be adapted to engage ratchet surfaces 706 as seen in Figure 66 to rotate a cartridge. The finger 570 may also incorporate vertical motion to coordinate with the rising and lowering of the cartridge

500. The motion of finger 570 may also be powered by electric actuators such as a stepper motor or other device useful for achieving motion. Figure 56B also shows a portion of the encoder 573 used in position sensing.

Referring now to Figure 56C, a still further view of the slider 564 and arm 569 is shown.

5 The arm 569 moves to engage portion 522 as indicated by arrow 575 and this causes the cam 550 to rotate as indicated by arrow 577. In this particular embodiment, the cam 550 rotates about 1/8 of an rotation with each pull of the slider 564. When the slider 564 is return to its home or start position, the arm 569 rides over the portion 522. The movement of the slider also allows the cam surface 544 to rotate about pivot point 579. A resilient member 580 may be coupled to the cam
10 surface 544 to cause it to rotate counterclockwise when the arm 569 moves in the direction of arrow 567. The pin 580 will remain in contact with the arm 569. As the cam surface 544 rotates a first surface 582 will contact the pin 583 on the gripper block 584 and pull the pin 583 back to park a penetrating member into a coupling or narrowed portion 542 of the cartridge 500 as seen in Figure 55A. As the arm 569 is brought back to the home position, the cam surface 544 rotates
15 back and a second surface 586 that rotates clockwise and pushes the penetrating member forward to be released from the narrowed portion 542 resulting in a position as seen in Figure 55B. It should be understood that in some embodiments, the release and/or parking of lancet from portion 542 may be powered by the driver 588 without using the mechanical assistance from cam surface 544.

20 In another embodiment of the cartridge device, a mechanical feature may be included on the cartridge so that there is only one way to load it into the apparatus. For example, in one embodiment holding 50 penetrating members, the cartridge may have 51 pockets or cavities. The 51st pocket will go into the firing position when the device is loaded, thus providing a location for the gripper to rest in the cartridge without releasing a penetrating member from a
25 sterile environment. The gripper 530 in that zeroth position is inside the pocket or cavity and that is the reason why one of the pockets may be empty. Of course, some embodiments may have the gripper 530 positioned to grip a penetrating member as the cartridge 500 is loaded into the device, with the patient lancing themselves soon afterwards so that the penetrating member is not contaminated due to prolonged exposure outside the sterile enclosure. That zeroth position
30 may be the start and finish position. The cartridge may also be notched to engaged a protrusion on the apparatus, thus also providing a method for allowing the penetrating member to loaded or unloaded only in one orientation. Essentially, the cartridge 500 may be keyed or slotted in association with the apparatus so that the cartridge 500 can only be inserted or removed at one

orientation. For example as seen in Figure 56D, the cartridge 592 may have a keyed slot 593 that matches the outline of a protrusion 594 such that the cartridge 592 may only be removed upon alignment of the slot 593 and protrusion 594 upon at the start or end positions. It should be understood that other keyed technology may be used and the slot or key may be located on an outer periphery or other location on the cartridge 592 in manner useful for allowing insertion or removal of the cartridge from only one or a select number of orientations.

Referring now to Figure 57, a cross-section of another embodiment of a cavity 600 housing a penetrating member is shown. The cavity 600 may include a depression 602 for allowing the gripper 530 to penetrate sufficiently deeply into the cavity to frictionally engage the penetrating member 541. The penetrating member may also be housed in a groove 604 that holds the penetrating member in place prior to and after actuation. The penetrating member 541 is lifted upward to clear the groove 604 during actuation and exits through opening 506.

Referring now to Figure 58, another variation on the system according to the present invention will now be described. Figure 58 shows a lancing system 610 wherein the penetrating members have their sharpened tip pointed radially inward. The finger or other tissue of the patient is inserted through the center hole 611 to be pierced by the member 612. The penetrating member gripper 530 coupled to drive force generator 613 operate in substantially the same manner as described in Figures 54A-G. The punch portions 521 and 522 operate in substantially the same manner to release the penetrating members from the sterile enclosures. The punch portion 522 may be placed on the inner periphery of the device, where the penetrating member exit is now located, so that sterile enclosure material is cleared out of the path of the penetrating member exit.

Referring now to Figure 59, a still further variation on the lancing system according to the present invention will now be described. In the embodiments shown in Figures 53-54, the penetrating member gripper 530 approaches the penetrating member from above and at least a portion of the drive system is located in a different plane from that of the cartridge 500. Figure 59 shows an embodiment where the penetrating member driver 620 is in substantially the same plane as the penetrating member 622. The coupler 624 engages a bent or L shaped portion 626 of the member 622. The cartridge 628 can rotate to engage a new penetrating member with the coupler 624 without having to move the cartridge or coupler vertically. The next penetrating member rotates into position in the slot provided by the coupler 624. A narrowed portion of the cartridge acts as a penetrating member guide 630 near the distal end of the penetrating member to align the penetrating member as it exits the cartridge.

The coupler 624 may come in a variety of configurations. For example, Figure 60A shows a coupler 632 which can engage a penetrating member 633 that does not have a bent or L-shaped portion. A radial cartridge carrying such a penetrating member 633 may rotate to slide penetrating member into the groove 634 of the coupler 632. Figure 60B is a front view showing that the coupler 632 may include a tapered portion 636 to guide the penetrating member 633 into the slot 634. Figure 60C shows an embodiment of the driver 620 using a coupler 637 having a slot 638 for receiving a T-shaped penetrating member. The coupler 637 may further include a protrusion 639 that may be guided in an overhead slot to maintain alignment of the drive shaft during actuation.

Referring now to Figure 61, a cartridge 640 for use with an in-plane driver 620 is shown. The cartridge 640 includes an empty slot 642 that allows the cartridge to be placed in position with the driver 620. In this embodiment, the empty slot 642 allows the coupler 644 to be positioned to engage an unused penetrating member 645 that may be rotated into position as shown by arrow 646. As seen in Figure 61, the cartridge 640 may also be designed so that only the portion of the penetrating member that needs to remain sterile (i.e. the portions that may actually be penetrating into tissue) are enclosed. As seen in Figure 61, a proximal portion 647 of the penetrating member is exposed. This exposed proximal portion may be about 70% of the penetrating member. In other embodiments it may be between about 69% to about 5% of the penetrating member. The cartridge 640 may further include, but not necessarily, sealing protrusions 648. These protrusions 648 are releasably coupled to the cartridge 640 and are removed from the cartridge 640 by remover 649 as the cartridge rotates to place penetrating member 645 into the position of the active penetrating member. The sterile environment is broken prior to actuation of the member 645 and the member does not penetrate sterile enclosure material that may dull the tip of the penetrating member during actuation. A fracturable seal material 650 may be applied to the member to seal against an inner peripheral portion of the cartridge.

Referring now to Figure 62, a still further embodiment of a cartridge for use with the present invention will be described. This cartridge 652 includes a tapered portion 654 for allowing the coupler 655 to enter the cavity 656. A narrowed portion 657 guides the penetrating member 658. The coupler 655 may have, but does not necessarily have, movable jaws 659 that engage to grip the penetrating member 658. Allowing the coupler to enter the cavity 656 allows the alignment of the penetrating member to be better maintained during actuation. This tapered portion 654 may be adapted for use with any embodiment of the cartridge disclosed herein.

Referring now to Figure 63, a linear cartridge 660 for use with the present invention will be described. Although the present invention has been shown in use with radial cartridges, the lancing system may be adapted for use with cartridges of other shapes. Figures 79-83 show other cartridges of varying shapes adaptable for use with the present invention. Figure 63 illustrates a cartridge 660 with only a portion 662 providing sterile protection for the penetrating members. The cartridge 660, however, provides a base 664 on which a penetrating member 665 can rest. This provides a level of protection of the penetrating member during handling. The base 664 may also be shaped to provide slots 666 in which a penetrating member 667 may be held. The slot 666 may also be adapted to have a tapered portion 668. These configurations may be adapted for use with any of the embodiments disclosed herein, such as the cartridge 652.

Referring now to Figures 64A-64C, a variety of different devices are shown for releasing the sterility seal covering a lateral opening 503 on the cartridge 500. Figure 64A shows a rotating punch device 670 that has protrusions 672 that punch out the sterility barrier creating openings 674 from which a penetrating member can exit without touching the sterility barrier material. Figure 64B shows a vertically rotating device 676 with shaped protrusions 678 that punch down the sterility barrier 679 as it is rotated to be in the active, firing position. Figure 64C shows a punch 680 which is positioned to punch out barrier 682 when the cartridge is lowered onto the punch. The cartridge is rotated and the punch 680 rotates with the cartridge. After the cartridge is rotated to the proper position and lifted up, the punch 680 is spring loaded or otherwise configured to return to the position to engage the sterility barrier covering the next unused penetrating member.

Referring now to Figure 65A-65B, another type of punch mechanism for use with a punch plate 520 will now be described. The device shown in Figures 53-54 shows a mechanism that first punches and then rotates or indexes the released penetrating member into position. In this present embodiment, the cartridge is rotated first and then the gripper and punch may move down simultaneously. Figure 65A shows a punch 685 having a first portion 686 and a second portion 687. As seen in cross-sectional view of Figure 65B, the penetrating member gripper 690 is located inside the punch 685. Thus the penetrating of the sterility barrier is integrated into the step of engaging the penetrating member with the gripper 690. The punch 685 may include a slot 692 allowing a portion 694 of the gripper 690 to extend upward. A lateral opening 695 is provided from which a penetrating member may exit. In some embodiments, the punch portion 687 is not included with punch 686, instead relying on some other mechanism such as those shown in Figures 64A-64C to press down on barrier material covering a lateral opening 503.

Referring now to Figures 66, a still further embodiment of a cartridge according to the present invention will be described. Figure 66 shows a cartridge 700 with a plurality of cavities 702 and individual deflectable portions or fingers 704. The ends of the protective cavities 702 may be divided into individual fingers (such as one for each cavity) on the outer periphery of the disc. Each finger 704 may be individually sealed with a foil cover (not shown for ease of illustration) to maintain sterility until the time of use. Along the inner periphery of the cartridge 700 are raised step portions 706 to create a ratchet type mechanism. As seen in Figure 67, a penetrating member 708 may be housed in each cavity. The penetrating member may rest on a raised portion 710. A narrowed portion 712 pinches the proximal portions of the penetration member 708. Each cavity may include a wall portion 714 into which the penetrating member 708 may be driven after the penetrating member has been used. Figure 68 shows the penetrating member gripper 716 lowered to engage a penetrating member 708. For ease of illustration, a sterility barrier covering each of the cavities is not shown.

Referring now to Figures 69A-69L, the sequence of steps for actuating a penetrating member in a cartridge 700 will be described. It should be understood that in other embodiments, steps may be combined or reduced without departing from the spirit of the present invention. The last penetrating member to be used may be left in a retracted position, captured by a gripper 716. The end of the protective cavity 704 may be deflected downward by the previous actuation. The user may operate a mechanism such as but not limited to a thumbwheel, lever, crank, slider, etc...that advances a new penetrating member 720 into launch position as seen in Figure 69A. The mechanism lifts a bar that allows the protective cavity to return to its original position in the plane of the disc.

In this embodiment as shown in Figure 69B, the penetrating member guide 722 presses through foil in rear of pocket to "home" penetrating member and control vertical clearance. For ease of illustration, actuation devices for moving the penetrating member guide 722 and other mechanisms are not shown. They may be springs, cams, or other devices that can lower and move the components shown in these figures. In some embodiments, the cartridge 700 may be raised or lowered to engage the penetrating member guide 722 and other devices.

As seen in Figure 69C, the plough or sterile enclosure release device 724 is lowered to engage the cartridge 700. In some embodiments, the disc or cartridge 700 may raised part way upward until a plough or plow blade 724 pierces the sterility barrier 726 which may be a foil covering.

Referring now to Figure 69D, the plough 724 clears foil from front of pocket and leaves it attached to cartridge 700. The plough 724 is driven radially inward, cutting open the sterility barrier and rolling the scrap into a coil ahead of the plough. Foil naturally curls over and forms tight coil when plough lead angle is around 55degs to horizontal. If angle of the plough may be
5 between about 60-40degs, preferably closer to 55 degs. In some embodiments, the foil may be removed in such a manner that the penetrating member does not need to pierce any sterile enclosure materials during launch.

Referring now to Figure 69E, the gripper 716 may be lowered to engage the bare penetrating member or piercing member 720. Optionally, the disc or cartridge 8000 may be
10 raised until the penetrating member 720 is pressed firmly into the gripper 716. Although not shown in the present figure, the penetrating member driver or actuator of the present embodiment may remain in the same horizontal plane as the penetrating member.

As seen in Figure 69F, a bar 730 may be pressed downward on the outer end 732 of the protective cavity to deflect it so it is clear of the path of the penetrating member. In the present
15 embodiment, the bar 730 is shaped to allow the bare penetrating member 720 to pass through. It should be understood that other shapes and orientations of the bar (such as contacting only one side or part of end 732) may be used to engage the end 732.

Referring now to Figure 69G, an electrical solenoid or other electronic or feed-back controllable drive may actuate the gripper 716 radially outward, carrying the bare penetrating
20 member 720 with it. The bare penetrating member projects from the protective case and into the skin of a finger or other tissue site that has been placed over the aperture of the actuator assembly. Suitable penetrating member drivers are described in commonly assigned, copending U.S. Patent Application Ser. No. 10/127,395 (Attorney Docket No. 38187-2551) filed April 19, 2002.

Referring now to Figure 69H, the solenoid or other suitable penetrating member driver retracts the bare penetrating member 720 into a retracted position where it parks until the
25 beginning of the next lancing cycle.

Referring now to Figure 69I, bar 730 may be released so that the end 150 returns to an in-plane configuration with the cartridge 800.

As seen in Figure 69J, the gripper 716 may drive a used bare penetrating member radially
30 outward until the sharpened tip is embedded into a plastic wall 714 at or near the outward end 732 of the cavity thus immobilizing the contaminated penetrating member.

As seen in Figures 69K and 69L, the plough 724, the gripper 716, and penetrating member guide 722 may all be disengaged from the bare penetrating member 720. Optionally, it should be understood that the advance mechanism may lower the cartridge 700 from the gripper 716. The used penetrating member, restrained by the tip embedded in plastic, and by the cover foil at the opposite end, is stripped from the gripper. The disc or cartridge 700 may be rotated
5 until a new, sealed; sterile penetrating member is in position under the launch mechanism.

Referring now to Figures 70 and 71, one object for some embodiments of the invention is to include blood sampling and sensing on this penetrating member actuation device. In the present embodiment, the drive mechanism (gripper 738 and solenoid drive coil 739) may be used to drive a penetrating member into the skin and couple this lancing event to acquire the blood sample as it forms at the surface of the finger. In a first embodiment shown in Figure 70, microfluidic module 740 bearing the analyte detecting member chemistry and detection device 742 (Figure 71) is couple on to the shaft of the penetrating member 720. The drive cycle described above may also actuate the module 740 so that it rests at the surface of the finger to acquire blood once the penetrating member retracts from the wound. The module 740 is allowed to remain on the surface of the finger or other tissue site until the gripper 738 has reached the back end 744 of the microfluidics module 740, at which point the module is also retracted into the casing. The amount of time the module 740 remains on the finger, in this embodiment, may be varied based on the distance the end 744 is located and the amount of time it takes the gripper to engage it on the withdrawal stroke. The blood filled module 740, filled while the module remains on pierced tissue site, may then undergo analyte detection by means such as optical or electrochemical sensing.

The blood may be filled in the lumen that the penetrating member was in or the module may have separately defined sample chambers to the side of the penetrating member lumen. The analyte detecting member may also be placed right at the immediate vicinity or slightly setback from the module opening receiving blood so that low blood volumes will still reach the analyte detecting member. In some embodiments, the analyte sensing device and a visual display or other interface may be on board the apparatus and thus provide a readout of analyte levels without need to plug apparatus or a test strip into a separate reader device. As seen in Figure 71, the cover 746 may also be clear to allow for light to pass through for optical sensing. The analyte detecting member may be used with low volumes such as less than about 1 microliter of sample, preferably less than about 0.6 microliter, more preferably less than about 0.3 microliter, and most preferably less than about 0.1 microliter of sample.

In another embodiment as seen in Figure 72, sensing elements 760 may be directly printed or formed on the top of bottom of the penetrating member cartridge 700, depending on orientation. The bare penetrating member 720 is then actuated through a hole 762 in the plastic facing, withdrawn into the radial cavity followed by the blood sample. Electrochemical or optical detection for analyte sensing may then be carried out (Figure 72). Again the cavity 766 may have a clear portion to allow light to pass for optical sensing. In one embodiment, a multiplicity of

miniaturized analyte detecting member fields may be placed on the floor of the radial cavity as shown in Figure 72 or on the microfluidic module shown in Figure 71 to allow many tests on a single analyte from a single drop of blood to improve accuracy and precision of measurement. Although not limited in this manner, additional analyte detecting member fields or regions may also be included for calibration or other purposes.

Referring now to Figure 73, a still further embodiment of a cartridge according to the present invention will be described. Figure 73 shows one embodiment of a cartridge 800 which may be removably inserted into an apparatus for driving penetrating members to pierce skin or other tissue. The cartridge 800 has a plurality of penetrating members 802 that may be individually or otherwise selectively actuated so that the penetrating members 802 may extend outward from the cartridge, as indicated by arrow 804, to penetrate tissue. In the present embodiment, the cartridge 800 may be based on a flat disc with a number of penetrating members such as, but in no way limited to, (25, 50, 75, 100, ...) arranged radially on the disc or cartridge 800. It should be understood that although the cartridge 800 is shown as a disc or a disc-shaped housing, other shapes or configurations of the cartridge may also work without departing from the spirit of the present invention of placing a plurality of penetrating members to be engaged by a penetrating member driver.

Each penetrating member 802 may be contained in a molded cavity 806 in the cartridge 800 with the penetrating member's sharpened end facing radially outward and may be in the same plane as that of the cartridge. Although not limited in this manner, the ends of the protective cavities 806 may be divided into individual fingers (such as one for each cavity) on the outer periphery of the disc. The particular shape of each cavity 806 may be designed to suit the size or shape of the penetrating member therein or the amount of space desired for placement of the analyte detecting members 808. For example and not limitation, the cavity 806 may have a V-shaped cross-section, a U-shaped cross-section, C-shaped cross-section, a multi-level cross section or the other cross-sections. The opening 810 through which a penetrating member 802 may exit to penetrate tissue may also have a variety of shapes, such as but not limited to, a circular opening, a square or rectangular opening, a U-shaped opening, a narrow opening that only allows the penetrating member to pass, an opening with more clearance on the sides, a slit, a configuration as shown in Figure 75, or the other shapes.

After actuation, the penetrating member 802 is returned into the cartridge and may be held within the cartridge 800 in a manner so that it is not able to be used again. By way of example and not limitation, a used penetrating member may be returned into the cartridge and

held by the launcher in position until the next lancing event. At the time of the next lancing, the launcher may disengage the used penetrating member with the cartridge 800 turned or indexed to the next clean penetrating member such that the cavity holding the used penetrating member is position so that it is not accessible to the user (i.e. turn away from a penetrating member exit opening). In some embodiments, the tip of a used penetrating member may be driven into a protective stop that hold the penetrating member in place after use. The cartridge 800 is replaceable with a new cartridge 800 once all the penetrating members have been used or at such other time or condition as deemed desirable by the user.

Referring still to Figure 73, the cartridge 800 may provide sterile environments for penetrating members via seals, foils, covers, polymeric, or similar materials used to seal the cavities and provide enclosed areas for the penetrating members to rest in. In the present embodiment, a foil or seal layer 820 is applied to one surface of the cartridge 800. The seal layer 820 may be made of a variety of materials such as a metallic foil or other seal materials and may be of a tensile strength and other quality that may provide a sealed, sterile environment until the seal layer 820 is penetrate by a suitable or penetrating device providing a preselected or selected amount of force to open the sealed, sterile environment. Each cavity 806 may be individually sealed with a layer 820 in a manner such that the opening of one cavity does not interfere with the sterility in an adjacent or other cavity in the cartridge 800. As seen in the embodiment of Figure 73, the seal layer 820 may be a planar material that is adhered to a top surface of the cartridge 800.

Depending on the orientation of the cartridge 800 in the penetrating member driver apparatus, the seal layer 820 may be on the top surface, side surface, bottom surface, or other positioned surface. For ease of illustration and discussion of the embodiment of Figure 73, the layer 820 is placed on a top surface of the cartridge 800. The cavities 806 holding the penetrating members 802 are sealed on by the foil layer 820 and thus create the sterile environments for the penetrating members. The foil layer 820 may seal a plurality of cavities 806 or only a select number of cavities as desired.

In a still further feature of Figure 73, the cartridge 800 may optionally include a plurality of analyte detecting members 808 on a substrate 822 which may be attached to a bottom surface of the cartridge 800. The substrate may be made of a material such as, but not limited to, a polymer, a foil, or other material suitable for attaching to a cartridge and holding the analyte detecting members 808. As seen in Figure 73, the substrate 822 may hold a plurality of analyte detecting members, such as but not limited to, about 10-50, 50-100, or other combinations of

analyte detecting members. This facilitates the assembly and integration of analyte detecting members 808 with cartridge 800. These analyte detecting members 808 may enable an integrated body fluid sampling system where the penetrating members 802 create a wound tract in a target tissue, which expresses body fluid that flows into the cartridge for analyte detection by at least one of the analyte detecting members 808. The substrate 822 may contain any number of analyte detecting members 808 suitable for detecting analytes in cartridge having a plurality of cavities 806. In one embodiment, many analyte detecting members 808 may be printed onto a single substrate 822 which is then adhered to the cartridge to facilitate manufacturing and simplify assembly. The analyte detecting members 808 may be electrochemical in nature. The analyte detecting members 808 may further contain enzymes, dyes, or other detectors which react when exposed to the desired analyte. Additionally, the analyte detecting members 808 may comprise of clear optical windows that allow light to pass into the body fluid for analyte analysis. The number, location, and type of analyte detecting member 808 may be varied as desired, based in part on the design of the cartridge, number of analytes to be measured, the need for analyte detecting member calibration, and the sensitivity of the analyte detecting members. If the cartridge 800 uses a analyte detecting member arrangement where the analyte detecting members are on a substrate attached to the bottom of the cartridge, there may be through holes (as shown in Figure 76), wicking elements, capillary tube or other devices on the cartridge 800 to allow body fluid to flow from the cartridge to the analyte detecting members 808 for analysis. In other configurations, the analyte detecting members 808 may be printed, formed, or otherwise located directly in the cavities housing the penetrating members 802 or areas on the cartridge surface that receive blood after lancing.

The use of the seal layer 820 and substrate or analyte detecting member layer 822 may facilitate the manufacture of these cartridges 10. For example, a single seal layer 820 may be adhered, attached, or otherwise coupled to the cartridge 800 as indicated by arrows 824 to seal many of the cavities 806 at one time. A sheet 822 of analyte detecting members may also be adhered, attached, or otherwise coupled to the cartridge 800 as indicated by arrows 825 to provide many analyte detecting members on the cartridge at one time. During manufacturing of one embodiment of the present invention, the cartridge 800 may be loaded with penetrating members 802, sealed with layer 820 and a temporary layer (not shown) on the bottom where substrate 822 would later go, to provide a sealed environment for the penetrating members. This assembly with the temporary bottom layer is then taken to be sterilized. After sterilization, the assembly is taken to a clean room where the temporary bottom layer is removed and the substrate

822 with analyte detecting members is coupled to the cartridge as shown in Figure 73. This process allows for the sterile assembly of the cartridge with the penetrating members 802 using processes and/or temperatures that may degrade the accuracy or functionality of the analyte detecting members on substrate 822.

5 In some embodiments, more than one seal layer 820 may be used to seal the cavities 806. As examples of some embodiments, multiple layers may be placed over each cavity 806, half or some selected portion of the cavities may be sealed with one layer with the other half or selected portion of the cavities sealed with another sheet or layer, different shaped cavities may use different seal layer, or the like. The seal layer 820 may have different physical properties, such as those covering the penetrating members 802 near the end of the cartridge may have a different color such as red to indicate to the user (if visually inspectable) that the user is down to say 10, 5, or other number of penetrating members before the cartridge should be changed out.

Referring now to Figure 74 and 75, one embodiment of the microfluidics used with the analyte detecting members 808 in cartridge 800 will now be described. For ease of illustration, the shape of cavity 806 has been simplified into a simple wedge shape. It should be understood that more sophisticated configurations such as that shown in Figure 73 may be used. Figure 74 shows a channel 826 that assists in drawing body fluid towards the analyte detecting members 808. In the present embodiment, two analyte detecting members 808 are shown in the cavity 806. This is purely for illustrative purposes as the cavity 806 may have only one analyte detecting member or any other number of analyte detecting members as desired. Body fluid entering cavity 806, while filling part of the cavity, will also be drawn by capillary action through the groove 826 towards the analyte detecting members 808.

Figure 75 shows a perspective view of a cutout of the cavity 806. The penetrating member 802 (shown in phantom) is housed in the cavity 806 and may extend outward through a penetrating member exit opening 830 as indicated by arrow 832. The position of the tip of penetrating member 802 may vary, such as being near the penetrating member exit port or spaced apart from the exit. The location of the tip relative to the analyte detecting member 808 may also be varied, such as being spaced apart or away from the analyte detecting member or collocated or in the immediate vicinity of the analyte detecting member. Fluid may then enter the cavity 806 and directed by channel 826. The channel 826 as shown in Figure 75 is a groove that is open on top. The channel 826 may be entirely a groove with an open top or it may have a portion that is has a sealed top forming a lumen, or still further, the groove may be closed except for an opening near the penetrating member exit opening 830. It should be understood that

capillary action can be achieved using a groove having one surface uncovered. In some embodiments, the analyte detecting member 808 is positioned close to the penetrating member exit opening 830 so that the analyte detecting member 808 may not need a capillary groove or channel to draw body fluid, such as in Figure 78.

5 As seen in Figures 75 and 76, the cavity 806 may include the substrate 822 coupled to its bottom surface containing the analyte detecting members 808. With the analyte detecting members 808 located on the underside of the cartridge 800 as seen in Figure 76, the cartridge 800 may include at least one through hole 834 to provide a passage for body fluid to pass from the cavity 806 to the analyte detecting member 808. The size, location, shape, and other features
10 of the through hole 834 may be varied based on the cavity 806 and number of analyte detecting members 808 to be provided. In other embodiments, wicking elements or the like may be used to draw body fluid from the groove 826 to down to the analyte detecting member 808 via the through hole or holes 834.

Referring now to Figure 77, a variety of groove and analyte detecting member
15 configurations are shown on a single cartridge. These configurations are shown only for illustrative purposes and a single cartridge may not incorporate each of these configurations. It should be understood, however, that analyte detecting member configuration could be customized for each cavity, such as but not limited to, using a different number and location of analyte detecting members depending lancing variables associated with that cavity, such as the
20 time of day of the lancing event, the type of analyte to be measured, the test site to be lanced, or other lancing parameter.

Figure 77 shows a penetrating member 802 in a cavity 838 with three analyte detecting members 808 in the cavity. For ease of illustration, the penetrating member 802 is omitted from the remaining cavities so that the analyte detecting member configurations can be more easily
25 seen. Cavity 840 has a channel 826 with two analyte detecting members 808. Cavity 842 has a channel 844 coupled to a single analyte detecting member 808. Cavities 846 and 848 have one and two analyte detecting members 808, respectively. The analyte detecting members 808 in those cavities may be located directly at the penetrating member exit from the cartridge or substantially at the penetrating member exit. Other analyte detecting member configurations are
30 also possible, such as but not limited to, placing one or more analyte detecting members on a side wall of the cavity, placing the analyte detecting members in particular arrays (for example, a linear array, triangular array, square array, etc..) on the side wall or bottom surface, using mixed types of analyte detecting members (for example, electrochemical and optical, or some other

combination), or mixed positioning of analyte detecting members (for example, at least one analyte detecting member on the substrate below the cartridge and at least one analyte detecting member in the cavity).

Figure 78 shows an embodiment of cartridge 800 where the analyte detecting member 850 is located near the distal end of cavity 806. The analyte detecting member 850 may be formed, deposited, or otherwise attached there to the cartridge 800. In another embodiment, the analyte detecting member 850 may be a well or indentation having a bottom with sufficient transparency to allow an optical analyte detecting member to detect analytes in fluid deposited in the well or indentation. The well or indentation may also include some analyte reagent that reacts (fluoresces, changes colors, or presents other detectable qualities) when body fluid is placed in the well. In a still further embodiment, analyte detecting member 850 may be replaced with a through hole that allow fluid to pass there through. A analyte detecting member 808 on a substrate 822 may be attached to the underside of the cartridge 800, accessing fluid passing from the cavity 806 down to the analyte detecting member 808.

As mentioned above, the analyte detecting members 808 may also be placed right at the immediate vicinity or slightly setback from the module opening receiving blood so that low blood volumes will still reach the analyte detecting member. The analyte detecting members 808 may be used with low volumes such as less than about 1 microliter of sample, preferably less than about 0.6 microliter, more preferably less than about 0.3 microliter, and most preferably less than about 0.1 microliter of sample. Analyte detecting members 808 may also be directly printed or formed on the bottom of the penetrating member cartridge 800. In one embodiment, a multiplicity of miniaturized analyte detecting member fields may be placed on the floor of the radial cavity or on the microfluidic module to allow many tests on a single analyte form a single drop of blood to improve accuracy and precision of measurement. Although not limited in this manner, additional analyte detecting member fields or regions may also be included for calibration or other purposes.

Referring now to Figures 79-84, further embodiments of the cartridge 800 will now be described. Figure 79 shows a cartridge 860 having a half-circular shape. Figure 80 shows a cartridge 862 in the shape of a partial curve. Figure 80 also shows that the cartridges 862 may be stacked in various configurations such as vertically, horizontally, or in other orientations. Figure 81 shows a cartridge 864 having a substantially straight, linear configuration. Figure 82 shows a plurality of cartridges 864 arranged to extend radially outward from a center 866. Each cartridge may be on a slide (not shown for simplicity) that allows the cartridge 864 to slide radially

outward to be aligned with a penetrating member launcher. After use, the cartridge 864 is slide back towards the center 866 and the entire assembly is rotated as indicated by arrow 868 to bring a new cartridge 864 into position for use with a penetrating member driver. Figure 83 shows a still further embodiment where a plurality of cartridges 800 may be stacked for use with a penetrating member driver (see Figure 85). The driver may be moved to align itself with each cartridge 800 or the cartridges may be moved to align themselves with the driver. Figure 84 shows a still further embodiment where a plurality of cartridge 864 are coupled together with a flexible support to define an array. A roller 870 may be used to move the cartridges 864 into position to be actuated by the penetrating member driver 872.

Referring now to Figure 85, one embodiment of an apparatus 880 using a radial cartridge 800 with a penetrating member driver 882 is shown. A contoured surface 884 is located near a penetrating member exit port 886, allowing for a patient to place their finger in position for lancing. Although not shown, the apparatus 880 may include a human readable or other type of visual display to relay status to the user. The display may also show measured analyte levels or other measurement or feedback to the user without the need to plug apparatus 880 or a separate test strip into a separate analyte reader device. The apparatus 880 may include a processor or other logic for actuating the penetrating member or for measuring the analyte levels. The cartridge 800 may be loaded into the apparatus 880 by opening a top housing of the apparatus which may be hinged or removably coupled to a bottom housing. The cartridge 800 may also be drawn into the apparatus 880 using a loading mechanism similar in spirit to that found on a compact disc player or the like. In such an embodiment, the apparatus may have a slot (similar to a CD player in an automobile) that allows for the insertion of the cartridge 800 into the apparatus 880 which is then automatically loaded into position or otherwise seated in the apparatus for operation therein. The loading mechanism may be mechanically powered or electrically powered. In some embodiments, the loading mechanism may use a loading tray in addition to the slot. The slot may be placed higher on the housing so that the cartridge 800 will have enough clearance to be loaded into the device and then dropped down over the penetrating member driver 882. The cartridge 800 may have an indicator mark or indexing device that allows the cartridge to be properly aligned by the loading mechanism or an aligning mechanism once the cartridge 800 is placed into the apparatus 880. The cartridge 800 may rest on a radial platform that rotates about the penetrating member driver 882, thus providing a method for advancing the cartridge to bring unused penetrating members to engagement with the penetrating member driver. The cartridge 800 on its underside or other surface, may shaped or contoured

such as with notches, grooves, tractor holes, optical markers, or the like to facilitate handling and/or indexing of the cartridge. These shapes or surfaces may also be varied so as to indicate that the cartridge is almost out of unused penetrating members, that there are only five penetrating members left, or some other cartridge status indicator as desired.

5 A suitable method and apparatus for loading penetrating members has been described previously in commonly assigned, copending U.S. patent applications Attorney Docket 38187-2589 and 38187-2590, and are included here by reference for all purposes. Suitable devices for engaging the penetrating members and for removing protective materials associated with the penetrating member cavity are described in commonly assigned, copending U.S. patent
10 applications Attorney Docket 38187-2601 and 38187-2602, and are included here by reference for all purposes. For example in the embodiment of Figure 78, the foil or seal layer 820 may cover the cavity by extending across the cavity along a top surface 890 and down along the angled surface 892 to provide a sealed, sterile environment for the penetrating member and analyte detecting members therein. A piercing element described in U.S. patent applications
15 Attorney Docket 38187-2602 has a piercing element and then a shaped portion behind the element which pushes the foil to the sides of the cavity or other position so that the penetrating member 802 may be actuated and body fluid may flow into the cavity.

Referring now to Figure 86, a still further embodiment of a lancing system according to the present invention will be described. A radial cartridge 500 may be incorporated for use with
20 a penetrating member driver 882. A penetrating member may be driven outward as indicated by arrow 894. A plurality of analyte detecting members are presented on a roll 895 that is laid out near a penetrating member exit. The roll 895 may be advanced as indicated by arrow 896 so that used analyte detecting members are moved away from the active site. The roll 895 may also be replaced by a disc holding a plurality of analyte detecting members, wherein the analyte
25 detecting member disc (not shown) is oriented in a plane substantially orthogonal to the plane of cartridge 500. The analyte detecting member disc may also be at other angles not parallel to the plane of cartridge 500 so as to be able to rotate and present new, unused analyte detecting member in sequence with new unused penetrating members of cartridge 500.

Referring now to Figure 87A, the cartridge 500 provides a high density packaging system
30 for a lancing system. This form factor allows a patient to load a large number penetrating members through a single cartridge while maintaining a substantially handheld device. Of course such a cartridge 500 may also be used in non-handheld devices. The present cartridge 500 provide a high test density per volume of the disposable. For embodiments of a cartridge

that includes analyte detecting members in addition to penetrating members such as cartridge 800, the density may also be measured in terms of density of analyte detecting members and penetrating members in a disposable. In other embodiments, the density may also be expressed in terms of analyte detecting members per disposable. For example, by taking the physical
5 volume of one embodiment or the total envelope, this number can be divided by the number of penetrating members or number of tests. This result is the volume per penetrating member or per test in a cassetted fashion. For example, in one embodiment of the present invention, the total volume of the cartridge 500 is determined to be 4.53 cubic centimeters. In this one embodiment, the cartridge 500 holds 50 penetrating members. Dividing the volume by 50, the volume per test
10 is arrived at 0.090 cubic centimeters. Conventional test devices such as drum is in the range of 0.720 or 0.670 cubic centimeters and that is simply the volume to hold a plurality of test strips. This does not include penetrating members as does the present embodiment 800. Thus, the present embodiment is at a substantially higher density. Even a slightly lower density device having penetrating members and analyte detecting members in the 0.500 cubic centimeter range
15 would be a vast improvement over known devices since the numbers listed above for known devices does not include penetrating members, only packaging per test strip.

Each penetrating member (or penetrating member and analyte detecting member, as the case may be) may have a packing density, or occupied volume, in cartridge 500. In various
20 embodiments, the packing density or occupied volume of each penetrating member in cartridge 500 may be no more than about 0.66 cm³, 0.05 cm³, 0.4 cm³, 0.3 cm³, 0.2 cm³, 0.1 cm³, 0.075 cm³, 0.05 cm³, 0.025 cm³, 0.01 cm³, 0.090 cm³, 0.080 cm³, and the like. These numbers applicable to volumes for penetrating members alone, or for combined penetrating members and analyte detecting members. In other words, the volume required for each penetrating member does not exceed 0.66 cm³/penetrating member, 0.05 cm³/penetrating member, 0.4
25 cm³/penetrating member, 0.3 cm³/penetrating member, 0.2 cm³/penetrating member, 0.1 cm³/penetrating member, 0.075 cm³/penetrating member, 0.05 cm³/penetrating member, 0.025 cm³/penetrating member, 0.01 cm³/penetrating member, 0.090 cm³/penetrating member and the like. So, if the total package volume of the cartridge is defined as X and the cartridge includes Y number of penetrating members, penetrating members and test area, or other unit 395, the
30 volume for each unit does not exceed 0.66 cm³, 0.05 cm³, 0.4 cm³, 0.3 cm³, 0.2 cm³, 0.1 cm³, 0.075 cm³, 0.05 cm³, 0.025 cm³, 0.01 cm³, 0.090 cm³, 0.080 cm³, and the like.

Referring now to Figure 87B, a still further embodiment of a cartridge according to the present invention will now be described. Figure 87B shows a cross-section of a conical shaped

cartridge with the penetrating member being oriented in one embodiment to move radially outward as indicated by arrow 897. In another embodiment, the penetrating member may be oriented to move radially inward as indicated by arrow 895. The gripper may be positioned to engage the penetrating member from an inner surface or an outer surface of the cartridge.

5 Referring now to Figure 88, nanowires may also be used to create low volume analyte detecting members used with the cartridge 800. Further details of a nanowire device is described in commonly assigned, copending U.S. Provisional Patent Application Ser. No. _____ (Attorney Docket No. 38187-2605) filed December 13, 2002, fully incorporated herein by reference for all purposes. These nanowire analyte detecting members 898 may be incorporated
10 into the cavity 806 housing the penetrating member 802. They may be placed on the floor or bottom surface of the cavity 806, on the wall, on the top surface, or any combinations of some or all of these possibilities. The analyte detecting members 898 may be designed to have different sensitivity ranges so as to enhance the overall sensitivity of an array of such analyte detecting members. Methods to achieve this may include, but are not limited to, using nanowires of
15 varying sizes, varying the number of nanowires, or varying the amount of glucose oxidase or other glucose detection material on the nanowires. These nanowire analyte detecting members may be designed to use low volumes of body fluid for each sample, due to their size. In some embodiments, each of the analyte detecting members are accurate using volumes of body fluid sample less than about 500 nanoliters. In some embodiments, each of the analyte detecting
20 members are accurate using volumes of body fluid sample less than about 300 nanoliters. In still other embodiments, each analyte detecting member is accurate with less than about 50 nanoliters, less than about 30 nanoliters, less than about 10 nanoliters, less than about 5 nanoliters, and less than about 1 nanoliters of body fluid sample. In some embodiments, the combined array of analyte detecting members uses less than 300 nanoliters of body fluid to
25 arrive at an analyte measurement.

Referring now to Figure 89, a still further embodiment of the present invention will be described. Figure 89 shows one embodiment of an optical illumination system 910 for use with optical analyte detecting members (Figure 91) that may be in contact with a body fluid sample. The overall system may include a plurality of analyte detecting members which provide some
30 optical indicator, a light source 912 for providing light to shine on the analyte detecting members, at least one light detector 914, and a processor (not shown). The analyte detecting member or analyte detecting members are exposed to a sample of the fluid of unknown composition. A plurality of analyte detecting members may be arranged into an array of analyte

detecting members exposed to one fluid sample, each group targeting a specific analyte and may contain an analyte-specific chemical that interacts more specifically with one analyte than with some other analytes to be analyzed. Each analyte detecting member may also have different sensitivity ranges so as to maximize overall sensitivity of an array of such analyte detecting members. The light source 912 shines light on at least one analyte detecting member to cause light interaction. The differences in the analyte detecting members may lead to differences in the light interaction. The light detector detects the light interaction by the analyte detecting members. The processor analyzes the light interaction by the analyte detecting members to take into account interference in light interaction among the analytes, thereby determining the concentration of the desired analyte in the fluid.

Referring still to the embodiment of Figure 89, the light source 912 may be but is not limited to an LED. An alternative LED 915 may also be used with the present invention. Light, illumination, or excitation energy from LED 912 travels along a path through a pinhole 916, a filter 917, and a lens 918. The light then comes into contact with a beamsplitter 919 such as a dichroic mirror or other device useful for beamsplitting. The light is then directed towards lens 920 as indicated by arrow 921. The lens 920 focuses light onto the analyte detecting member (Figure 91). This excitation energy may cause a detectable optical indicator from the analyte detecting member. By way of example and not limitation, fluorescence energy may be reflected back up the lens 920. This energy passes through the beamsplitter 919 and to lens 922 which is then received by detector 914 as indicated by arrow 923. The detector 914 measures the energy and this information is passed on to the processor (not shown) to determine analyte levels. The illumination system 910 may also include cells 924 on the disc surface. In this specific embodiment, a penetrating member 925 driven by a force generator 926 such as but not limited to a solenoid may be used to obtain the fluid sample. A detent 927 may also be included with the device along with other bare lancets or penetrating members 928.

Referring now to Figure 90, another embodiment of the illumination system 910 is shown for use with a cartridge 929. Cartridge 929 is similar to cartridge 800. Cartridge 929 is a single cartridge having a plurality of penetrating members and a plurality of optical analyte detecting members (not shown). The cartridge 929 further includes a plurality of optically transparent portions 930 which may be but is not limited to windows or the like for the light from LED 912 to shine into a cavity of the cartridge 929. In one embodiment, each cavity of the cartridge 929 may include at least one transparent portion 930. This allows the light to generate energy that

may be read by analyte detecting member 914. The cartridge 929 may be used a driver 882 to actuate penetrating members and the cartridge 929 may rotate as indicated by arrow 931.

Referring now to Figure 91, a cross-section of a similar embodiment of the illumination system is shown. This system 932 has source 912 with a lens 933 having an excitation filter 934. This excitation filter 934, in one embodiment, only allows excitation energy to pass. This filter 934 allows the excitation energy to pass to dichroic mirror 935, but does not let it return to source 912. Excitation energy is reflected down as indicated by arrow 936. Lens 937 focuses the energy to optical analyte detecting member 938. Fluorescence energy 939 passes through the dichroic mirror 935 and towards a fluorescent filter 940. In one embodiment, the fluorescent filter 940 only allows fluorescent energy to pass through to lens 941. Thus, the detector 914 only receives fluorescent energy from the analyte detecting member 938. It should be understood of course, that the filter may be changed to allow the type of energy being generated by analyte detecting member 938 to pass. In some embodiments, no filter may be used. The dichroic mirror 935 may be a Bk7 substrate, 63x40x8mm. The filters may also be a Bk7 substrate about 40mm in diameter and about 6mm thick. The lens 933, 937, and 941 may be achomat:bfl=53.6, working aperture 38mm.

Referring now to Figure 92, a still further embodiment of an illumination system 942 will be described. This system does not use a beamsplitter or dichroic mirror. Instead, both the source or LED 912 and detector 914 have direct line of sight to the optical analyte detecting member 938. In this embodiment, multiple elements are combined into a single housing. For example, lens 943, lens 944, and filter 945 are combined while lens 946, lens 947, and filter 948 are also combined.

Referring now to Figure 93, a cross-section of a system similar to that of Figure 89 is shown in a housing 950. LED 912 sends light to mirror 919 to a light path 951 to cells 924 on a surface of the disc. A finger access 952 allows a sample to be obtained and flow along a fluid pathway 953 to be analyzed. A processor 954 may be coupled to detector 914 to analyze the results.

Referring now to Figure 94, a cross-section of a system similar to that of Figure 90 will be further described. This shows a cartridge 929 used with a driver 882. This allows for a radial design where the penetrating members extend radially outward as indicated by arrow 955. The driver 882 may have a coupler portion that reciprocates as indicated by arrow 956. Figures 95 and 96 provide further views of a system similar to that of Figure 89. The embodiment of

77

Figures 95 and 96 may include additional lenses or filters as may be useful to refine energy detection.

While the invention has been described and illustrated with reference to certain particular embodiments thereof, those skilled in the art will appreciate that various adaptations, changes, modifications, substitutions, deletions, or additions of procedures and protocols may be made without departing from the spirit and scope of the invention. For example, with any of the above
5 embodiments, the location of the penetrating member drive device may be varied, relative to the penetrating members or the cartridge. With any of the above embodiments, the penetrating member tips may be uncovered during actuation (i.e. penetrating members do not pierce the penetrating member enclosure or protective foil during launch). With any of the above
10 embodiments, the penetrating members may be a bare penetrating member during launch. With any of the above embodiments, the penetrating members may be bare penetrating members prior to launch as this may allow for significantly tighter densities of penetrating members. In some embodiments, the penetrating members may be bent, curved, textured, shaped, or otherwise treated at a proximal end or area to facilitate handling by an actuator. The penetrating member may be configured to have a notch or groove to facilitate coupling to a gripper. The notch or
15 groove may be formed along an elongate portion of the penetrating member. With any of the above embodiments, the cavity may be on the bottom or the top of the cartridge, with the gripper on the other side. In some embodiments, analyte detecting members may be printed on the top, bottom, or side of the cavities. The front end of the cartridge maybe in contact with a user during lancing. The same driver may be used for advancing and retraction of the penetrating
20 member. The penetrating member may have a diameters and length suitable for obtaining the blood volumes described herein. The penetrating member driver may also be in substantially the same plane as the cartridge. The driver may use a through hole or other opening to engage a proximal end of a penetrating member to actuate the penetrating member along a path into and out of the tissue.

25 Any of the features described in this application or any reference disclosed herein may be adapted for use with any embodiment of the present invention. For example, the devices of the present invention may also be combined for use with injection penetrating members or needles as described in commonly assigned, copending U.S. Patent Application Ser. No. 10/127,395 (Attorney Docket No. 38187-2551) filed April 19, 2002. A analyte detecting member to detect
30 the presence of foil may also be included in the lancing apparatus. For example, if a cavity has been used before, the foil or sterility barrier will be punched. The analyte detecting member can detect if the cavity is fresh or not based on the status of the barrier. It should be understood that in optional embodiments, the sterility barrier may be designed to pierce a sterility barrier of

thickness that does not dull a tip of the penetrating member. The lancing apparatus may also use improved drive mechanisms. For example, a solenoid force generator may be improved to try to increase the amount of force the solenoid can generate for a given current. A solenoid for use with the present invention may have five coils and in the present embodiment the slug is roughly the size of two coils. One change is to increase the thickness of the outer metal shell or windings surround the coils. By increasing the thickness, the flux will also be increased. The slug may be split; two smaller slugs may also be used and offset by $\frac{1}{2}$ of a coil pitch. This allows more slugs to be approaching a coil where it could be accelerated. This creates more events where a slug is approaching a coil, creating a more efficient system.

In another optional alternative embodiment, a gripper in the inner end of the protective cavity may hold the penetrating member during shipment and after use, eliminating the feature of using the foil, protective end, or other part to retain the used penetrating member. Some other advantages of the disclosed embodiments and features of additional embodiments include: same mechanism for transferring the used penetrating members to a storage area; a high number of penetrating members such as 25, 50, 75, 100, 500, or more penetrating members may be put on a disk or cartridge; molded body about a lancet becomes unnecessary; manufacturing of multiple penetrating member devices is simplified through the use of cartridges; handling is possible of bare rods metal wires, without any additional structural features, to actuate them into tissue; maintaining extreme (better than 50 micron -lateral- and better than 20 micron vertical) precision in guiding; and storage system for new and used penetrating members, with individual cavities/slots is provided. The housing of the lancing device may also be sized to be ergonomically pleasing. In one embodiment, the device has a width of about 56 mm, a length of about 105 mm and a thickness of about 15 mm. Additionally, some embodiments of the present invention may be used with non-electrical force generators or drive mechanism. For example, the punch device and methods for releasing the penetrating members from sterile enclosures could be adapted for use with spring based launchers. The gripper using a frictional coupling may also be adapted for use with other drive technologies.

Still further optional features may be included with the present invention. For example, with any of the above embodiments, the location of the penetrating member drive device may be varied, relative to the penetrating members or the cartridge. With any of the above embodiments, the penetrating member tips may be uncovered during actuation (i.e. penetrating members do not pierce the penetrating member enclosure or protective foil during launch). The penetrating members may be a bare penetrating member during launch. The same driver may be

used for advancing and retraction of the penetrating member. Different analyte detecting members detecting different ranges of glucose concentration, different analytes, or the like may be combined for use with each penetrating member. Non-potentiometric measurement techniques may also be used for analyte detection. For example, direct electron transfer of

5 glucose oxidase molecules adsorbed onto carbon nanotube powder microelectrode may be used to measure glucose levels. In some embodiments, the analyte detecting members may formed to flush with the cartridge so that a “well” is not formed. In some other embodiments, the analyte detecting members may formed to be substantially flush (within 200 microns or 100 microns) with the cartridge surfaces. In all methods, nanoscopic wire growth can be carried out via

10 chemical vapor deposition (CVD). In all of the embodiments of the invention, preferred nanoscopic wires may be nanotubes. Any method useful for depositing a glucose oxidase or other analyte detection material on a nanowire or nanotube may be used with the present invention. This application cross-references commonly assigned copending U.S. Patent Applications Ser. No. 10/323,622 (Attorney Docket No. 38187-2606) filed December 18, 2002;

15 commonly assigned copending U.S. Patent Applications Ser. No. 10/323,623 (Attorney Docket No. 38187-2607) filed December 18, 2002; and commonly assigned copending U.S. Patent Applications Ser. No. 10/323,624 (Attorney Docket No. 38187-2608) filed December 18, 2002. This application is also related to commonly assigned copending U.S. Patent Applications Ser. Nos. 10/335,215; 10/335,258; 10/335,099; 10/335,219; 10/335,052; 10/335,073; 10/335,220;

20 10/335,252; 10/335,218; 10/335,211; 10/335,257; 10/335,217; 10/335,212; 10/335,241; 10/335,183; 10/335,082; 10/335,240; 10/335,259; 10/335,182; (Attorney Docket No. 38187-2633 through 38187-2652) filed December 31, 2002. All applications listed above are fully incorporated herein by reference for all purposes. Expected variations or differences in the results are contemplated in accordance with the objects and practices of the present invention. It

25 is intended, therefore, that the invention be defined by the scope of the claims which follow and that such claims be interpreted as broadly as is reasonable.

WHAT IS CLAIMED IS:

- 1 1. A device for use with a penetrating member driver to penetrate tissue, the
2 device comprising:
3 a single cartridge having a plurality of penetrating members;
4 a plurality of analyte detecting members, said analyte detecting members
5 positioned to receive body fluid from a wound in the tissue created by the penetrating member.
- 1 2. A device for use with a penetrating member driver to penetrate tissue, the
2 device comprising:
3 a single cartridge;
4 a plurality of penetrating members coupled to said single cartridge and
5 operatively couplable to the penetrating member driver, said penetrating members movable to
6 extend radially outward from the cartridge to penetrate tissue;
7 a plurality of optical analyte detecting members coupled to said single cartridge,
8 said analyte detecting members positioned on the cartridge to receive body fluid from a wound in
9 the tissue created by the penetrating member.
- 1 3. The device of claim 2 wherein cartridge includes a plurality of transparent
2 windows aligned with said optical analyte detecting members.
- 1 4. The device of claim 2 wherein said penetrating members are slidably
2 coupled to said cartridge.
- 1 5. The device of claim 2 wherein at least one optical analyte detecting
2 member is associated with at least one of said penetrating members.
- 1 6. The device of claim 2 wherein said cartridge is a flat radial disc.
- 1 7. The device of claim 2 wherein said cartridge has a diameter of less than 6
2 cm.
- 1 8. The device of claim 2 wherein said cartridge is a unitary body.
- 1 9. The device of claim 2 wherein said penetrating members are not attached
2 by a resilient member to the cartridge.

1 10. The device of claim 2 wherein said optical analyte detecting members are
2 configured to determine analyte levels using a body fluid sample of less than about 1 microliter.

1 11. The device of claim 2 wherein said optical analyte detecting members are
2 configured to determine analyte levels using a body fluid sample of less than about 300
3 nanoliters.

1 12. The device of claim 2 wherein said optical analyte detecting members are
2 mounted on said cartridge.

1 13. The device of claim 2 wherein each of said optical analyte detecting
2 members comprises an array of analyte detecting members.

1 14. The device of claim 2 wherein each of said optical analyte detecting
2 members comprises an array of analyte detecting members wherein a plurality of said array
3 analyte detecting members have different ranges of analyte sensitivity.

1 15. The device of claim 2 wherein each of said optical analyte detecting
2 members comprises an array of analyte detecting members formed from nanowires.

1 16. The device of claim 2 wherein each of said penetrating members are
2 elongate members without molded attachments.

1 17. The device of claim 2 wherein each of said penetrating members are
2 elongate wires of substantially constant diameter.

1 18. The device of claim 2 wherein each of said penetrating members is made
2 of only one material selected from the following: a metal or a metal alloy.

1 19. A device for use with a penetrating member driver to penetrate tissue, the
2 device comprising:

3 a single cartridge having a plurality of openings;

4 a plurality of penetrating members having a sharpened tips movable to penetrate
5 tissue;

6 a plurality of optical analyte detecting members coupled to said single cartridge;

7 a sterility barrier covering said openings.

1 20. The device of claim 19 wherein cartridge includes a plurality of
2 transparent windows aligned with said optical analyte detecting members.

1 21. The device of claim 19 wherein said penetrating members with sharpened
2 distal ends and are arranged in a radial pattern pointing each of said sharpened distal ends
3 radially outward.

1 22. The device of claim 19 wherein said optical analyte detecting members are
2 positioned on the cartridge to receive body fluid from a wound in the tissue created by a
3 penetrating member.

1 23. The device of claim 19 wherein said optical analyte detecting members are
2 configured to determine analyte levels using a body fluid sample of less than about 1 microliter.

1 24. The device of claim 19 wherein said optical analyte detecting members are
2 configured to determine analyte levels using a body fluid sample of less than about 300
3 nanoliters.

1 25. The device of claim 19 wherein said sterility barrier, prior to being
2 breached, maintains a sterile environment inside said openings.

1 26. A device for use with a penetrating member driver to penetrate tissue, the
2 device comprising:

3 a single cartridge having a plurality of cavities;

4 a plurality of penetrating members coupled to said single cartridge and couplable
5 to the penetrating member driver, said penetrating members movable to extend outward to
6 penetrate tissue;

7 a plurality of optical analyte detecting members coupled to said single cartridge,
8 said analyte detecting members receiving body fluid entering said cavities.

1 27. The device of claim 26 wherein cartridge includes a plurality of
2 transparent windows aligned with said optical analyte detecting members.

1 28. The device of claim 26 wherein said analyte detecting members define a
2 portion of said cavities.

- 1 29. The device of claim 26 wherein said analyte detecting members are
2 mounted in said cavities.
- 1 30. The device of claim 26 further comprising a sterility barrier covering said
2 cavities.
- 1 31. The device of claim 26 wherein said optical analyte detecting members are
2 configured to determine analyte levels using a body fluid sample of less than about 1 microliter.
- 1 32. The device of claim 26 wherein said optical analyte detecting members are
2 configured to determine analyte levels using a body fluid sample of less than about 300
3 nanoliters.
- 1 33. The device of claim 26 wherein at least some of said optical analyte
2 detecting members are positioned on a bottom surface of said cavities.
- 1 34. The device of claim 26 wherein at least some of said optical analyte
2 detecting members are positioned on a side surface of said cavities.
- 1 35. The device of claim 26 wherein at least some of said optical analyte
2 detecting members are positioned on a top surface of said cavities.
- 1 36. The device of claim 26 wherein at least some of said optical analyte
2 detecting members are positioned on a curved surface of said cavities.
- 1 37. A device for use with a penetrating member driver to penetrate tissue, the
2 device comprising:
3 a single cartridge having a plurality of openings and a plurality of penetrating
4 member cavities;
5 a plurality of penetrating members at least partially contained in said cavities;
6 a plurality of analyte detecting members attached to a substrate, said substrate
7 couplable to said single cartridge in manner positioning at least one of said analyte detecting
8 members with each of said plurality of cavities.
- 1 38. The device of claim 37 wherein cartridge includes a plurality of optically
2 transparent portions aligned with said optical analyte detecting members.

1 39. The device of claim 37 wherein said substrate comprises a material
2 selected from: polymer, metallic foil, or paper.

1 40. The device of claim 37 wherein said substrate comprises a laminate made
2 from combinations of any of the following: polymer, metallic foil, or paper.

1 41. The device of claim 37 wherein said analyte detecting members define a
2 portion of said cavities.

1 42. The device of claim 37 further comprising a sterility barrier covering a
2 plurality of said openings.

1 43. The device of claim 37 wherein said optical analyte detecting members are
2 configured to determine analyte levels using a body fluid sample of less than about 1 microliter.

1 44. The device of claim 37 wherein said optical analyte detecting members are
2 configured to determine analyte levels using a body fluid sample of less than about 300
3 nanoliters.

1 45. A device for use with a penetrating member driver to penetrate tissue, the
2 device comprising:

3 a single cartridge having a plurality of openings and a plurality of cavities;

4 a plurality of penetrating members with at least one penetrating members in at
5 least one of said cavities;

6 a plurality of analyte detecting members on a layer of material couplable to said
7 single cartridge wherein at least two of said cavities each has at least one analyte detecting
8 member in fluid communication with one of said cavities, said analyte detecting members
9 positioned on the cartridge to receive body fluid from a wound in the tissue created by the
10 penetrating member.

1 46. A device comprising:

2 a single cartridge;

3 at least 50 penetrating members coupled to and at least partially housed in said
4 single cartridge wherein said cartridge has a diameter no greater than about 5 inches;

5 at least 50 optical analyte detecting members, each associated with one of said
6 penetrating members;

7 said penetrating members movable in an outward direction from the cartridge to
8 penetrate tissue when actuated by said penetrating member driver.

1 47. The system of claim 46, wherein the diameter is no great than about 5 cm.

1 48. The system of claim 46, wherein a volume of the cartridge does not
2 exceed a packing density of about 0.5 cm³ per penetrating member and optical analyte detecting
3 member.

1 49. The system of claim 46, wherein a volume of the cartridge does not
2 exceed a packing density of about 0.1 cm³ per penetrating member and optical analyte detecting
3 member.

1 50. A device comprising:
2 a single cartridge;
3 at least 100 penetrating members coupled to and at least partially housed in said
4 single cartridge wherein said cartridge has a diameter no greater than 6 inches;
5 at least 100 optical analyte detecting members, each associated with one of said
6 penetrating members;
7 said penetrating members movable in an outward direction from the cartridge to
8 penetrate tissue when actuated by said penetrating member driver.

1 51. The system of claim 50, wherein the diameter is no great than about 5 cm.

1 52. The system of claim 50, wherein a volume of the cartridge does not
2 exceed a packing density of about 0.5 cm³ per penetrating member and optical analyte detecting
3 member.

1 53. The system of claim 50, wherein a volume of the cartridge does not
2 exceed a packing density of about 0.1 cm³ penetrating member and optical analyte detecting
3 member.

1 54. A method comprising:
2 providing a cartridge having a plurality of penetrating members and a plurality of
3 optical analyte detecting members;
4 using a penetrating member driver to actuate said penetrating members to
5 penetrate tissue and wherein used penetrating members and analyte detecting members remain
6 coupled to said cartridge;

7 wherein said cartridge containing said used penetrating members and used analyte
8 detecting members, is disposable;

9 replacing the entire cartridge by inserting a new cartridge having penetrating
10 members and analyte detecting members into the penetrating member driver.

1 55. A lancing system comprising:

2 a penetrating member driver;

3 a plurality of penetrating members in a disc-shaped housing;

4 a penetrating member release device releasing the penetrating member for a
5 sterile environment prior to use and moving said penetrating member into position to be
6 operatively coupled to said penetrating member driver;

7 a plurality of sampling modules, wherein each of said modules is coupled to one
8 of said penetrating members and housed in said disc-shaped housing.

1 56. The system of claim 55 wherein said penetrating member driver is an
2 electric powered driver.

1 57. The system of claim 55 wherein said release device comprises a movable
2 member sufficient to pierce a penetrating member enclosure.

1 58. The system of claim 55 further comprising a penetrating member coupler
2 suitable for engaging one of the penetrating members and independently advancing one of the
3 penetrating members along a path outward from the housing, into a target tissue, and back into
4 the housing.

1 59. The system of claim 55 wherein said sample module has a sample
2 chamber volume of less than 1 microliter.

1 60. The system of claim 55 further comprising a penetrating member coupler
2 suitable for engaging one of the modules and advancing one of the modules and one of the
3 penetrating members such that said one of the lances advances along a path outward from the
4 housing, into a target tissue, and back into the housing.

1 61. A lancing system for use with a penetrating member driver, said system
2 comprising:

3 means for housing a plurality of penetrating members and optical analyte
4 detecting members;

5 means for releasing one of said penetrating member from a sealed enclosure on
6 said housing means;

7 means for operatively coupling one of said penetrating member to said
8 penetrating member driver;

9 wherein one of said optical analyte detecting members receives body fluid from a
10 wound created in said tissue by one of said penetrating members.

1 62. A body fluid sampling system comprising:

2 a cartridge;

3 a plurality of penetrating members coupled to said cartridge and selectively
4 actuatable to penetrate tissue, said penetrating members extending radially outward to penetrate
5 tissue;

6 a plurality of optical analyte detecting members coupled to said cartridge;
7 an electrically powered drive force generator configured to drive one of said
8 penetrating members in a launch position into a tissue site.

1 63. The system of claim 62 wherein cartridge includes a plurality of optically
2 transparent portions aligned with said optical analyte detecting members.

1 64. The system of claim 62 further comprising a light source for providing
2 excitation energy to one of said analyte detecting members.

1 65. The system of claim 62 further comprising a dichroic mirror.

1 66. The system of claim 62 further comprising an optical analyte detecting
2 member receiving reflected energy from one of said optical analyte detecting members.

1 67. A system as in claim 62 wherein said drive force generator is configured
2 to sequentially drive said penetrating members, each of said members moved from said launch
3 position along a path into and out of the tissue site.

1 68. A system as in claim 62 further comprising a penetrating member coupler
2 attached the drive force generator, the coupler configured to establish a frictional coupling with
3 one of said penetrating members in the launch position.

1 69. A system as in claim 62 further comprising means for moving said a
2 penetrating member into contact with a coupler of said drive force generator.

- 1 70. A system as in claim 62 wherein said penetrating member coupler is
2 vertically movable.
- 1 71. A system as in claim 62 further comprising an actuator for rotating said
2 radial cartridge.
- 1 72. A system as in claim 62 further comprising means for coupling the force
2 generator with one of said penetrating members.
- 1 73. A system as in claim 62 further comprising a penetrating member sensor
2 positioned to monitor a penetrating member coupled to said force generator, the penetrating
3 member sensor configured to provide information relative to a depth of penetration of a
4 penetrating member through a skin surface.
- 1 74. The system of claim 73, wherein the depth of penetration is about 100 to
2 2500 microns.
- 1 75. The system of claim 73, wherein the depth of penetration is 500 to 750
2 microns.
- 1 76. The system of claim 73, wherein the depth of penetration is no more than
2 about 1000 microns beyond a stratum corneum thickness of a skin surface.
- 1 77. The system of claim 73, wherein the depth of penetration is no more than
2 about 500 microns beyond a stratum corneum thickness of a skin surface.
- 1 78. The system of claim 73, wherein the depth of penetration is no more than
2 about 300 microns beyond a stratum corneum thickness of a skin surface.
- 1 79. The system of claim 73, wherein the depth of penetration is less than a
2 sum of a stratum corneum thickness of a skin surface and 400 microns..
- 1 80. The system of claim 73, wherein the penetrating member sensor is further
2 configured to control velocity of a penetrating member.
- 1 81. The system of claim 62, wherein the active penetrating member moves
2 along a substantially linear path into the tissue.

- 1 82. The system of claim 62, wherein the active penetrating member moves
2 along an at least partially curved path into the tissue.
- 1 83. The system of claim 62, wherein the driver is a voice coil drive force
2 generator.
- 1 84. The system of claim 62, wherein the driver is a rotary voice coil drive
2 force generator.
- 1 85. The system of claim 73, wherein the penetrating member sensor is coupled
2 to a processor with control instructions for the penetrating member driver.
- 1 86. The system of claim 85, wherein the processor includes a memory for
2 storage and retrieval of a set of penetrating member profiles utilized with the penetrating member
3 driver.
- 1 87. The system of claim 85, wherein the processor is utilized to monitor
2 position and speed of a penetrating member as the penetrating member moves in a first direction.
- 1 88. The system of claim 85, wherein the processor is utilized to adjust an
2 application of force to a penetrating member to achieve a desired speed of the penetrating
3 member.
- 1 89. The system of claim 85, wherein the processor is utilized to adjust an
2 application of force to a penetrating member when the penetrating member contacts a target
3 tissue so that the penetrating member penetrates the target tissue within a desired range of speed.
- 1 90. The system of claim 85, wherein the processor is utilized to monitor
2 position and speed of a penetrating member as the penetrating member moves in the first
3 direction toward a target tissue, wherein the application of a launching force to the penetrating
4 member is controlled based on position and speed of the penetrating member.
- 1 91. The system of claim 90, wherein the processor is utilized to control a
2 withdraw force to the penetrating member so that the penetrating member moves in a second
3 direction away from the target tissue.

1 92. The system of claim 91, wherein in the first direction the penetrating
2 member moves toward the target tissue at a speed that is different than a speed at which the
3 penetrating member moves away from the target tissue.

1 93. The system of claim 91, wherein in the first direction the penetrating
2 member moves toward the target tissue at a speed that is greater than a speed at which the
3 penetrating member moves away from the target tissue.

1 94. The system of claim 90, wherein a speed of a penetrating member in the
2 first direction is the range of about 2.0 to 10.0 m/sec.

1 95. The system of claim 91, wherein the average velocity of the penetrating
2 member during a tissue penetration stroke in the first direction is about 100 to about 1000 times
3 greater than the average velocity of the penetrating member during a withdrawal stroke in a
4 second direction.

1 96. The system of claim 73, wherein the penetrating member sensor includes a
2 capacitive incremental encoder.

1 97. The system of claim 73, wherein the penetrating member sensor includes
2 an incremental encoder.

1 98. The system of claim 73, wherein the penetrating member sensor includes
2 an optical encoder.

1 99. The system of claim 73, wherein the penetrating member sensor includes
2 an interference encoder.

1 100. The system of claim 62 wherein said penetrating member is advanced
2 along a path at a velocity following a lancing velocity profile.

1 101. The system of claim 62 further comprising a user interface configured to
2 relay at least one of, penetrating member performance or a penetrating member setting.

1 102. The system of claim 101, wherein the user interface is configured to
2 provide a user with at least one input selected from, depth of a penetrating member penetration,
3 velocity of a penetrating member, a desired velocity profile, a velocity of a penetrating member
4 into the target tissue, velocity of the penetrating member out of the target tissue, dwell time of

5 the penetrating member in the target tissue; tent and hold characteristic of the penetrating
6 member.

1 103. The system of claim 101, wherein the user interface provides at least one
2 output to the user selected from, number of penetrating members available, number of
3 penetrating members used, actual depth of penetrating member penetration on a target tissue
4 penetrating cycle, stratum corneum thickness, force delivered on a target tissue penetrating cycle,
5 energy used by a penetrating member driver to drive a penetrating member into the target tissue,
6 dwell time of the penetrating member, battery status, system status, consumed energy, and speed
7 profile of the penetrating member during a target tissue penetrating cycle.

1 104. The system of claim 101, wherein the user interface is selected from at
2 least one of, a visual display selected from: an LCD, LED, TFT, and a backlit LCD display.

1 105. The system of claim 101, wherein the user interface includes an input
2 device selected from a button, a touch pad, and a touch sensitive visual display.

1 106. The system of claim 101, further comprising:
2 a data exchange device for coupling a penetrating member driver to support
3 equipment.

1 107. The system of claim 106, wherein the support equipment is selected from
2 at least one of a personal computer, modem, PDA, and a computer network.

1 108. The system of claim 101, further comprising a data interface configured to
2 couple the skin penetrating system to support equipment with a data interface.

1 109. The system of claim 108, wherein the data interface is selected from at
2 least one of, Serial RS-232, modem interface, USB, HPNA, Ethernet, optical interface, IRDA,
3 RF interface, Bluetooth interface, cellular telephone interface, 2 way pager interface, parallel
4 port interface standard, near field magnetic coupling, and RF transceiver.

1 110. The system of claim 101, wherein the user interface includes a real time
2 clock and one or more alarms to provide a user with a reminder of a next target penetrating event
3 is needed.

1 111. The system of claim 62 wherein said optical analyte detecting members
2 are configured to determine analyte levels using a body fluid sample of less than about 1
3 microliter.

1 112. The system of claim 62 wherein said optical analyte detecting members
2 are configured to determine analyte levels using a body fluid sample of less than about 300
3 nanoliters.

1 113. The system of claim 62 wherein said optical analyte detecting members
2 are mounted on said cartridge.

1 114. The system of claim 62 wherein each of said optical analyte detecting
2 members comprises an array of analyte detecting members.

1 115. The system of claim 62 wherein each of said optical analyte detecting
2 members comprises an array of analyte detecting members wherein a plurality of said array
3 analyte detecting members have different ranges of analyte sensitivity.

1 116. The system of claim 62 wherein each of said optical analyte detecting
2 members comprises an array of analyte detecting members formed from nanowires.

1 117. The system of claim 62 wherein each of said penetrating members are
2 elongate members without molded attachments.

1 118. The system of claim 62 wherein each of said penetrating members are
2 elongate wires of substantially constant diameter.

1 119. The system of claim 62 wherein each of said penetrating members is made
2 of only one material selected from the following: a metal or a metal alloy.

1 120. A device for use in penetrating tissue to obtain a body fluid sample,
2 comprising:

3 a cartridge having a plurality of cavities; and

4 a plurality of penetrating members having sharpened tips and slidably coupled to
5 the cartridge, each of said penetrating members being moveable relative to the other ones of the
6 penetrating members along a path out of the cartridge to penetrate tissue;

7 a plurality of optical analyte detecting members wherein at least one of said
8 analyte detecting members is positioned to receive body fluid when one of said penetrating
9 members creates a wound in said tissue;

10 said penetrating members arranged with said sharpened tips pointing radially
11 outward;

12 wherein each of said cavities is defined in part by a deflectable portion, wherein
13 said deflectable portion in a first position prevents said penetrating member from exiting the
14 cartridge and said deflectable portion is movable to a second position creating an opening that
15 allows said lancet to extend outward from the cartridge.

1 121. The device of claim 120 wherein cartridge includes a plurality of optically
2 transparent portions aligned with said optical analyte detecting members.

1 122. The device of claim 120 wherein said portion is vertically deflectable.

1 123. The device of claim 120 wherein said portion is horizontally deflectable.

1 124. The device of claim 120 further comprising a sterility barrier over a planar
2 surface of the cartridge covering a plurality of longitudinal openings on the surface.

1 125. The device of claim 120 wherein each deflectable portion includes a
2 penetrable wall for receiving a sharpened tip of a used penetrating member.

1 126. The device of claim 120 further comprising a module mounted about one
2 of said penetrating member and having at least one of said optical analyte detecting members.

1 127. The device of claim 120 further comprising a module slidably mounted
2 about one of said penetrating member and having at least one of said optical analyte detecting
3 members, said module movable to be adjacent said wound in the tissue.

1 128. A manufacturing method comprising:
2 providing a cartridge having a plurality of cavities for holding penetrating
3 members;
4 sealing a plurality of cavities with a sterility barrier;
5 providing said cartridge with a plurality of optical analyte detecting members by
6 coupling a analyte detecting member layer to the cartridge.

1 129. The method of claim 128 further comprising providing said cartridge with
2 a plurality of optically transparent portions aligned with said optical analyte detecting members.

1 130. The method of claim 128 wherein said analyte detecting member layer
2 comprises said optical analyte detecting members secured to a material selected from the
3 following: polymer, foil, or paper.

1 131. The method of claim 128 wherein sealing creates a sterile environment in
2 said cavities.

1 132. The method of claim 128 further comprising applying a second sterility
2 barrier to said cartridge.

1 133. A manufacturing method comprising:
2 providing a cartridge having a plurality of cavities at least partially holding a
3 plurality of penetrating members;
4 sterilizing said cartridge while each of said cavities is in a sealed condition;
5 adding analyte detecting members to the cavities by opening cavities in a sterile
6 environment and coupling a analyte detecting member layer to the cartridge that provides the
7 analyte detecting members and resealing the cavities to maintain a sterile environment.

1 134. The method of claim 133 further comprising providing said cartridge with
2 a plurality of optically transparent portions aligned with said optical analyte detecting members.

1 135. The method of claim 133 further comprising adding a sterility barrier to
2 said cartridge.

1 136. The method of claim 133 wherein said providing for step comprises
2 adding a sterility barrier covering said cavities prior to sterilizing.

1 137. The method of claim 133 wherein said analyte detecting members include
2 components that cannot withstand a penetrating member sterilization process.

1 138. A method of driving a penetrating member into a tissue site to obtain a
2 body fluid sample, said method comprising:
3 providing a single cartridge having a plurality of penetrating members and a
4 plurality of optical analyte detecting members;

5 expressing fluid from a wound tract created by advancing one of said penetrating
6 members radially outward from the cartridge into a tissue site;

7 drawing fluid into said single cartridge which exposes at least one of said optical
8 analyte detecting members to said fluid.

1 139. The method of claim 138 further comprising providing said cartridge with
2 a plurality of optically transparent portions aligned with said optical analyte detecting members.

1 140. The method of claim 138 further comprising using an electric powered
2 drive force generator for advancing the penetrating member.

1 141. The method of claim 138 wherein said cartridge has a disc-shaped
2 configuration.

1 142. The method of claim 138 wherein each of said penetrating members are
2 elongate members without molded attachments.

1 143. The method of claim 138 wherein each of said penetrating members are
2 elongate wires of substantially constant diameter.

1 144. The method of claim 138 wherein each of said penetrating members is
2 made of only one material selected from the following: a metal or a metal alloy.

1 145. The method of claim 138 wherein said cartridge has a radial configuration
2 and is rotated to bring an unused penetrating member into a launch position for a drive force
3 generator.

1 146. A device for use in penetrating tissue to obtain a body fluid sample,
2 comprising:
3 a cartridge; and
4 a plurality of penetrating members slidably coupled to the cartridge, each of said
5 penetrating members having a distal end sufficiently sharp to pierce tissue, each of said
6 penetrating members being moveable relative to the other ones of the penetrating members so
7 that the sharpened distal ends extend radially outward to penetrate tissue;
8 wherein said penetrating members are elongate members without molded
9 attachments.

1 147. A device for use in penetrating tissue to obtain a body fluid sample,
2 comprising:
3 a cartridge having a plurality of cavities; and
4 a plurality of bare lancets having sharpened tips and slidably coupled to the
5 cartridge, each of said bare lancets being moveable relative to the other ones of the bare lancets
6 along a path out of the cartridge to penetrate tissue;
7 said bare lancets arranged with said sharpened tips pointing radially outward;
8 wherein each of said cavities is defined in part by a deflectable portion, wherein
9 said deflectable portion in a first position prevents said penetrating member from exiting the
10 cartridge and said deflectable portion is movable to a second position creating an opening that
11 allows said lancet to extend outward from the cartridge.

1 148. A device for use in penetrating tissue to obtain a body fluid sample,
2 comprising:

3 a cartridge having a plurality of cavities; and

4 a plurality of penetrating member slidably coupled to the cartridge, each of said
5 penetrating members at least partially housed in one of said cavities and being moveable relative
6 to the other ones of the penetrating members along a path out of the cartridge and into tissue;

7 a sterility barrier covering a plurality of openings on said cartridge and creating a
8 sterile environment in the plurality of cavities.

1 149. A device comprising:

2 a single radial cartridge;

3 a plurality of bare lancets slidably coupled to said cartridge and selectively
4 actuatable to penetrate tissue, each of said lancets having an longitudinal axis;

5 wherein the lancets are longitudinally oriented to be substantially in a common
6 plane.

1 150. A device comprising:

2 a cartridge;

3 a plurality of bare lancets slidably coupled to said cartridge and selectively
4 actuatable to penetrate tissue, each of said lancets having an longitudinal axis;

5 a first sterility barrier on a top surface of the cartridge;

6 a second sterility barrier another surface of the cartridge.

1 151. An apparatus for penetrating an organism comprising:

2 a penetrating member;

3 a first surface in physical contact with the penetrating member;

4 a second surface in physical contact with the penetrating member;

5 wherein the friction coefficient between the penetrating member and the second
6 surface is at least 15% less than the friction coefficient between the penetrating member and the
7 first surface.

1 152. A lancing device, comprising a penetrating member having a shaft with a
2 transverse slot configured to mate to a protuberance of a drive member.

1 153. A penetrating member, comprising a shaft having a friction enhanced
2 outer surface.

1 154. A device comprising:
2 a cartridge defining a plurality of cavities; and
3 a plurality of penetrating members at least partially contained in said cavities of
4 the single cartridge wherein the penetrating members are slidably movable to extend outward
5 from said cartridge to penetrate tissue, said cavities each having a longitudinal opening providing
6 access to an elongate portion of the penetrating member;
7 a sterility barrier coupled to said cartridge, said sterility barrier covering a
8 plurality of the longitudinal openings.

1 155. A device comprising:
2 a cartridge defining a plurality of cavities; and
3 a plurality of penetrating members at least partially contained in said cavities of
4 the single cartridge wherein the penetrating members are slidably movable to extend outward
5 from lateral openings on said cartridge to penetrate tissue;
6 a sterility barrier coupled to said cartridge, said sterility barrier covering a
7 plurality of said lateral openings.

1 156. A lancing system comprising:
2 a cartridge;
3 a plurality of penetrating members coupled to said cartridge and selectively
4 actuatable to penetrate tissue, said penetrating members extending radially outward to penetrate
5 tissue;
6 an electrically powered drive force generator operatively coupled to an active
7 penetrating member to drive said penetrating member into a tissue site.

1 157. A lancing system comprising:
2 a cartridge having an opening extending through a center of the cartridge;
3 a plurality of penetrating members coupled to said cartridge and selectively
4 actuatable to penetrate tissue, said penetrating members extending radially outward to penetrate
5 tissue;
6 a penetrating member driver at least partially positioned within said central
7 opening, said driver operatively couplable to an active penetrating member to drive said
8 penetrating member into a tissue site.

1 158. A lancing system comprising:

2 a single cartridge;
3 a plurality of penetrating members coupled to said single cartridge and selectively
4 actuatable to penetrate tissue;
5 an drive force generator operatively coupled to an active penetrating member to
6 drive said penetrating member into a tissue site;
7 a feedback loop for controlling the position of the active penetrating member
8 coupled to the drive force generator.

1 159. A lancing system comprising:
2 a single cartridge;
3 a plurality of penetrating members coupled to said single cartridge and selectively
4 actuatable to penetrate tissue;
5 an drive force generator operatively coupled to an active penetrating member to
6 drive said penetrating member into a tissue site;
7 said drive force generator actuating at least one of said penetrating members to
8 follow a velocity profile.

1 160. A device comprising:
2 a single cartridge;
3 a plurality of penetrating members coupled to said single cartridge and couplable
4 to a penetrating member driver;
5 a plurality of ratchet surfaces on said cartridge for advancing the cartridge.

1 161. A device comprising:
2 a single cartridge;
3 at least 50 penetrating members coupled to and at least partially housed in said
4 single cartridge wherein said cartridge has a diameter no greater than about 5 inches;
5 said penetrating members movable in an outward direction from the cartridge to
6 penetrate tissue when actuated by said penetrating member driver.

1 162. A device comprising:
2 a single cartridge;
3 at least 100 penetrating members coupled to and at least partially housed in said
4 single cartridge wherein said cartridge has a diameter no greater than 6 inches;
5 said penetrating members movable in an outward direction from the cartridge to
6 penetrate tissue when actuated by said penetrating member driver.

1 163. A lancing system comprising:
2 a plurality of cartridges each including a plurality of penetrating members coupled
3 to the cartridge and couplable to a penetrating member driver;
4 a cartridge loading device for moving at least one of said cartridges to be
5 operatively coupled to the penetrating member driver.

1 164. A lancing device comprising:
2 a penetrating member cartridge wherein penetrating members are retractable and
3 held within the cartridge so that they are not able to be used again.

165. A lancing device comprising:
a cartridge wherein the foil or seal broken by mechanism other than penetrating member.

1 166. A lancing system for use with a plurality of penetrating members, the
2 lancing system comprising:
3 a penetrating member driver;
4 a cartridge housing said plurality of penetrating members;
5 a penetrating member release device releasing one of the penetrating members
6 from a sterile environment prior to use;
7 a penetrating member coupling device wherein said cartridge is positionable for
8 one of said penetrating members to engage the coupler to be operatively coupled to said
9 penetrating member driver.

1 167. A manufacturing method comprising:
2 providing a cartridge having a plurality of cavities for holding penetrating
3 members;
4 sealing a plurality of cavities with a seal layer;
5 providing a plurality of analyte analyte detecting members by coupling a analyte
6 detecting member layer to the cartridge.

1 168. A manufacturing method comprising:
2 providing a cartridge having a plurality of cavities for holding penetrating
3 members;
4 sterilizing said cartridge while each of said cavities is in a sealed condition and
5 the cartridge contains at least one penetrating member;
6 applying a sterility barrier to said radial cartridge, said barrier covering a plurality
7 of cavities.

1 169. A method comprising:
2 transporting a plurality of penetrating members each in a sterilized environment
3 towards a penetrating member launch position;
4 releasing one of said penetrating members from a sterilized environment prior to
5 actuation;

6 moving said penetrating member to the launch position to be operatively coupled
7 to the penetrating member driver.

1 170. A method comprising:
2 providing a penetrating member driver;
3 installing a visual display on said penetrating member driver where said display
4 when coupled to a processor, relays penetrating member information selected from: lancing
5 performance or lancing setting.

1 171. A method comprising:
2 providing a cartridge having a plurality of penetrating members;
3 penetrating a sterility barrier and moving the barrier clear of a path of an active
4 one of the penetrating members;
5 forming a frictional coupling with the active one of the penetrating members;
6 actuating the active one of the penetrating members.

1 172. A method as in claim further comprising bending a portion of the
2 cartridge to create an opening for said penetrating member to exit the cartridge.

1 173. A method comprising:
2 providing a cartridge having a plurality of bare lancets;
3 forming a frictional coupling with the active one of the bare lancets;
4 actuating the active one of the penetrating members.

1 174. A device for use with a gripper, the device comprising:
2 a cartridge defining a plurality of cavities; and
3 a plurality of penetrating members at least partially contained in said cavities of
4 the cartridge wherein the penetrating members are slidably movable to extend outward from said
5 cartridge to penetrate tissue, said cavities each having a longitudinal opening providing access to
6 an elongate portion of the penetrating member;

7 a sterility barrier coupled to said cartridge, said sterility barrier covering a
8 plurality of the longitudinal openings, wherein the sterility barrier covering the lateral openings
9 is configured to be moved so that the elongate portion may be accessed by the gripper without
10 touching the barrier.

1 175. A device for use in penetrating tissue to obtain a body fluid sample,
2 comprising:
3 a cartridge; and
4 a plurality of penetrating members slidably coupled to the cartridge, each of said
5 penetrating members having a distal end sufficiently sharp to pierce tissue and each of said
6 penetrating members being moveable relative to the other ones of the penetrating members, so
7 that the distal end of the respective penetrating member is movable to penetrate tissue;
8 wherein each of said penetrating member is a bare lancet does not penetrate an
9 outer sterility barrier during actuation.

1 176. A device comprising:
2 a cartridge having a plurality of cavities; and
3 a plurality of penetrating members at least partially contained in said cavities of
4 the single cartridge wherein the penetrating members are slidably movable to extend outward
5 from lateral openings on said cartridge to penetrate tissue;

6 a sterility barrier coupled to said cartridge, said sterility barrier covering a
7 plurality of said lateral openings, wherein the sterility barrier covering the lateral openings is
8 configured to be moved so that a penetrating member exits the lateral opening without contacting
9 the barrier.

1 177. A device comprising means for housing a plurality of penetrating
2 members in a radial configuration, said penetrating members individually couplable to a driver.

1 178. A lancing system comprising:

2 a cartridge defining a plurality of cavities; and

3 a plurality of penetrating members at least partially contained in said cavities of
4 the single cartridge wherein the penetrating members are slidably movable to extend outward
5 from lateral openings on said cartridge to penetrate tissue;

6 a sterility barrier coupled to said cartridge, said sterility barrier covering at least
7 one of said lateral openings and configured to be moved so that a penetrating member exiting the
8 lateral opening during actuation will not contact the barrier;

9 an electrically powered drive force generator operatively coupled to an active one
10 of said penetrating members to drive the active penetrating member into a tissue site.

1 179. A lancing system comprising:

2 a cartridge defining a plurality of cavities; and

3 a plurality of penetrating members at least partially contained in said cavities of
4 the single cartridge wherein the penetrating members are slidably movable to extend outward
5 from lateral openings on said cartridge to penetrate tissue;

6 a sterility barrier coupled to said cartridge, said sterility barrier covering at least
7 one of said lateral openings and configured to be moved so that a penetrating member exiting the
8 lateral opening during actuation will not contact the barrier;

9 a feedback loop for controlling trajectory of each of said penetrating members
10 extending outward from the cartridge during actuation.

1 180. A lancing system comprising:

2 a single cartridge having a plurality of cavities;

3 a plurality of penetrating members at least partially contained in said cavities of
4 the single cartridge wherein the penetrating members are slidably movable to extend outward
5 from said cartridge to penetrate tissue, said cavities each having a longitudinal opening providing
6 access to an elongate portion of the penetrating member;

7 a sterility barrier coupled to said cartridge, said sterility barrier covering a
8 plurality of the longitudinal openings;

9 a punch movable to penetrate the sterility barrier and release one of the
10 penetrating members from a sterile environment created by the sterility barrier.

1 181. A lancing system comprising:

2 a single cartridge having a plurality of cavities;

3 a plurality of penetrating members at least partially contained in said cavities of
4 the single cartridge wherein the penetrating members are slidably movable to extend outward
5 from lateral openings on said cartridge to penetrate tissue;

6 a sterility barrier coupled to said cartridge, said sterility barrier covering a
7 plurality of said lateral openings;

8 a punch movable to penetrate the sterility barrier, pushing the sterility barrier into
9 a position so that the penetrating member may be actuated without contacting the sterility barrier.

1 182. A device comprising:

2 a single cartridge;

3 a plurality of penetrating members coupled to said single cartridge and couplable
4 to a driver;

5 a plurality of openings on said cartridge configured to position said cartridge to
6 align an unused penetrating member with the driver.

7 an actuator configured to engage the openings and actuate the cartridge to move
8 said unused penetrating member into alignment with the driver.

1 183. A lancing system comprising:

2 a driver;

3 a cartridge;

4 a plurality of bare lancets coupled to cartridge;

5 a lancet gripper coupled to the driver, wherein the gripper has a slot for receiving
6 at least one of the bare lancets, said slot creating a frictional grip with said one of the bare
7 lancets.

1 184. The system of claim 183 wherein the gripper has leg portions defining said
2 slot, said legs movable elastically to receive the bare lancet.

1 185. A lancing system comprising:

2 a lancet driver;

3 a plurality of lancets in a disc-shaped housing;
4 a lancet gripper;
5 a lancet release device for releasing the lancet for a sterile environment prior to
6 use; and
7 an actuator configured to move the disc-shaped housing relative to the lancet
8 gripper to bring one of said lancets into contact with the lancet gripper.

1 186. A lancing system comprising:
2 a lancet driver;
3 a cartridge housing said plurality of lancets;
4 a lancet gripper coupled to said lancet driver;
5 a lancet release device releasing one of the lancets from a sterile environment
6 prior to use;
7 said cartridge being movable relative to the lancet driver to engage and disengage
8 one of said lancets from the lancet gripper.

1 187. A lancing system for use with a driver, said system comprising:
2 means for releasing a penetrating member from a sterile enclosure on a cartridge,
3 said cartridge having a plurality of sterile enclosures and a plurality of penetrating members;
4 means for aligning and operatively coupling said penetrating member to said
5 driver.

1 188. A method comprising:
2 loading a cartridge having a plurality of penetrating members into a housing of a
3 lancing apparatus;
4 releasing said penetrating member from a sterilized environment on the cartridge;
5 transporting said penetrating member within the housing towards a launch
6 position;
7 loading said lancet to be operatively coupled to a penetrating member driver in
8 the apparatus.

1 189. A method comprising:
2 providing a cartridge having a plurality of individually sealed cavities each
3 containing a penetrating member;
4 lowering a punch plate to release an unused penetrating member from one of the
5 sealed cavities;
6 rotating the cartridge to align the unused penetrating member with a gripper;

7 creating a frictional engagement with the penetrating member by inserting the
8 penetrating member into a receiving slot on the gripper.

1 190. A method comprising:
2 providing a cartridge having a plurality of cavities each containing a penetrating
3 member, wherein each member is held by a coupling to the cartridge;
4 engaging a penetrating member with a gripper;
5 using a first force generator to move the gripper in a manner sufficient to release
6 the penetrating member from the coupling to the cartridge;
7 using a second force generator to move the gripper in a manner sufficient to drive
8 the penetrating member into tissue.

1 191. A method comprising:
2 providing a cartridge having a plurality of cavities each containing a penetrating
3 member, wherein each member is held by a coupling to the cartridge;
4 providing a punch device;
5 providing a penetrating member gripper;
6 creating relative motion between the cartridge and the gripper wherein the
7 cartridge is separated from the gripper;
8 creating relative motion between the cartridge and the gripper wherein the gripper
9 is aligned over an unused penetrating member in the cartridge;
10 creating relative motion between the cartridge and the gripper wherein the gripper
11 is engaged with the unused penetrating member.

1 192. A method comprising:
2 providing a lancet driver;
3 installing a visual display on said lancet driver where said display when coupled
4 to a processor, relays lancet information selected from: lancing performance or lancing setting.

1 193. A method comprising:
2 providing a cartridge having a plurality of cavities;
3 inserting a plurality of penetrating members at least partially contained in said
4 cavities of the cartridge wherein the penetrating members are slidably movable to extend
5 outward from lateral openings on said cartridge to penetrate tissue;
6 adding a sterility barrier to said cartridge, said sterility barrier covering a plurality
7 of said lateral openings.

194. A manufacturing method comprising:
providing a cartridge having a plurality of cavities for holding penetrating members;
sterilizing said cartridge while each of said cavities is in a sealed condition and the cartridge contains a plurality of penetrating members;
using a planar sheet of sterility barrier material to cover a plurality of said cavities to create a sterile environment inside each of said cavities.

195. A method comprising:
providing a cartridge having a plurality of bare lancets;
moving at least a portion of a sterility barrier such that an active one of said bare lancets exits the cartridge to penetrate tissue without contacting said sterility barrier;
retracting said active one of said bare lancets back into the cartridge after penetrating tissue.

1 196. A device for use with a penetrating member driver to penetrate tissue, the
2 device comprising:
3 a single cartridge;
4 a plurality of penetrating members coupled to said single cartridge and
5 operatively couplable to the penetrating member driver, said penetrating members movable to
6 extend radially outward from the cartridge to penetrate tissue;
7 a plurality of analyte analyte detecting members coupled to said single cartridge,
8 said analyte detecting members positioned on the cartridge to receive body fluid from a wound in
9 the tissue created by the penetrating member.

1 197. A device for use with a penetrating member driver to penetrate tissue, the
2 device comprising:
3 a single cartridge having a plurality of openings;
4 a plurality of penetrating members having a sharpened tips movable to penetrate
5 tissue;
6 a plurality of analyte analyte detecting members coupled to said single cartridge;
7 a sterility barrier covering said openings.

1 198. A device for use with a penetrating member driver to penetrate tissue, the
2 device comprising:

3 a single cartridge having a plurality of cavities;
4 a plurality of penetrating members coupled to said single cartridge and couplable
5 to the penetrating member driver, said penetrating members movable to extend outward to
6 penetrate tissue;
7 a plurality of analyte detecting members coupled to said single cartridge,
8 said analyte detecting members receiving body fluid entering said cavities.

1 199. A device for use with a penetrating member driver to penetrate tissue, the
2 device comprising:

3 a single cartridge having a plurality of openings and a plurality of penetrating
4 member cavities;

5 a plurality of penetrating members at least partially contained in said cavities;

6 a plurality of analyte detecting members attached to a substrate, said substrate
7 couplable to said single cartridge in manner positioning at least one of said analyte detecting
8 members with each of said plurality of cavities.

1 200. A device for use with a penetrating member driver to penetrate tissue, the
2 device comprising:

3 a single cartridge having a plurality of openings and a plurality of cavities;

4 a plurality of penetrating members with at least one penetrating members in at
5 least one of said cavities;

6 a plurality of analyte detecting members on a layer of material couplable to said
7 single cartridge wherein at least two of said cavities each has at least one analyte detecting
8 member in fluid communication with one of said cavities, said analyte detecting members
9 positioned on the cartridge to receive body fluid from a wound in the tissue created by the
10 penetrating member.

1 201. A device comprising:

2 a single cartridge;

3 at least 50 penetrating members coupled to and at least partially housed in said
4 single cartridge wherein said cartridge has a diameter no greater than about 5 inches;

5 at least 50 analyte detecting members, each associated with one of said
6 penetrating members;

7 said penetrating members movable in an outward direction from the cartridge to
8 penetrate tissue when actuated by said penetrating member driver.

1 202. A device comprising:

2 a single cartridge;
3 at least 100 penetrating members coupled to and at least partially housed in said
4 single cartridge wherein said cartridge has a diameter no greater than 6 inches;
5 at least 100 analyte analyte detecting members, each associated with one of said
6 penetrating members;
7 said penetrating members movable in an outward direction from the cartridge to
8 penetrate tissue when actuated by said penetrating member driver.

1 203. A method comprising:
2 providing a cartridge having a plurality of penetrating members and a plurality of
3 analyte analyte detecting members;
4 using a penetrating member driver to actuate said penetrating members to
5 penetrate tissue and wherein used penetrating members and analyte detecting members remain
6 coupled to said cartridge;
7 wherein said cartridge containing said used penetrating members and used analyte
8 detecting members, is disposable;
9 replacing the entire cartridge by inserting a new cartridge having penetrating
10 members and analyte detecting members into the penetrating member driver.

1 204. A lancing system comprising:
2 a penetrating member driver;
3 a plurality of penetrating members in a disc-shaped housing;
4 a penetrating member release device releasing the penetrating member for a
5 sterile environment prior to use and moving said penetrating member into position to be
6 operatively coupled to said penetrating member driver;
7 a plurality of sampling modules, wherein each of said modules is coupled to one
8 of said penetrating members and housed in said disc-shaped housing.

1 205. A lancing system for use with a penetrating member driver, said system
2 comprising:
3 means for housing a plurality of penetrating members and analyte analyte
4 detecting members;
5 means for releasing one of said penetrating member from a sealed enclosure on
6 said housing means;
7 means for operatively coupling one of said penetrating member to said
8 penetrating member driver;

9 wherein one of said analyte analyte detecting members receives body fluid from a
10 wound created in said tissue by one of said penetrating members.

1 206. A body fluid sampling system comprising:

2 a cartridge;

3 a plurality of penetrating members coupled to said cartridge and selectively
4 actuatable to penetrate tissue, said penetrating members extending radially outward to penetrate
5 tissue;

6 a plurality of analyte analyte detecting members coupled to said cartridge;

7 an electrically powered drive force generator configured to drive one of said
8 penetrating members in a launch position into a tissue site.

1 207. A device for use in penetrating tissue to obtain a body fluid sample,
2 comprising:

3 a cartridge having a plurality of cavities; and

4 a plurality of penetrating members having sharpened tips and slidably coupled to
5 the cartridge, each of said penetrating members being moveable relative to the other ones of the
6 penetrating members along a path out of the cartridge to penetrate tissue;

7 a plurality of analyte analyte detecting members wherein at least one of said
8 analyte detecting members is positioned to receive body fluid when one of said penetrating
9 members creates a wound in said tissue;

10 said penetrating members arranged with said sharpened tips pointing radially
11 outward;

12 wherein each of said cavities is defined in part by a deflectable portion, wherein
13 said deflectable portion in a first position prevents said penetrating member from exiting the
14 cartridge and said deflectable portion is movable to a second position creating an opening that
15 allows said lancet to extend outward from the cartridge.

1 208. A manufacturing method comprising:

2 providing a cartridge having a plurality of cavities for holding penetrating
3 members;

4 sealing a plurality of cavities with a sterility barrier;

5 providing said cartridge with a plurality of analyte analyte detecting members by
6 coupling a analyte detecting member layer to the cartridge.

1 209. A manufacturing method comprising:

2 providing a cartridge having a plurality of cavities at least partially holding a
3 plurality of penetrating members;

4 sterilizing said cartridge while each of said cavities is in a sealed condition;

5 adding analyte detecting members to the cavities by opening cavities in a sterile
6 environment and coupling a analyte detecting member layer to the cartridge that provides the
7 analyte detecting members and resealing the cavities to maintain a sterile environment.

1 210. A method of driving a penetrating member into a tissue site to obtain a
2 body fluid sample, said method comprising:

3 providing a single cartridge having a plurality of penetrating members and a
4 plurality of analyte analyte detecting members;

5 expressing fluid from a wound tract created by advancing one of said penetrating
6 members radially outward from the cartridge into a tissue site;

7 drawing fluid into said single cartridge which exposes at least one of said analyte
8 analyte detecting members to said fluid.

1 211. A method for determining a concentration of an analyte in body fluid,
2 comprising:

3 collecting a sample of body fluid of about 500 nL or less;

4 filling a measurement zone of an electrochemical analyte detecting member with
5 at least a portion of the sample;

6 determining the concentration of the analyte in the sample using a potentiometric
7 technique.

1 212. A method comprising:

2 creating an unassisted flow of a body fluid from the patient;

3 transporting a portion of the body fluid into an analyte analyte detecting member
4 configured and arranged to determine the concentration of the analyte from 500 nL or less of
5 body fluid; and

6 determining the concentration of the analyte in the body fluid from the portion of
7 the body fluid transported into the analyte analyte detecting member.

1 213. A device comprising:

2 a plurality of analyte analyte detecting members defining an array;

3 wherein at least two of said analyte detecting members have different sensitivity
4 ranges enhancing the overall range of sensitivity of the array when used on a sample fluid.

1 214. A system comprising:
2 a cartridge housing a plurality of penetrating members;
3 a punch for penetrating a sterility barrier on the cartridge;
4 a cam for sequencing the punch to penetrate the barrier to release at least one of
5 the penetrating members from a sterile environment.

1 215. A system comprising:
2 a cartridge housing a plurality of penetrating members;
3 a punch for penetrating a sterility barrier on the cartridge;
4 a cam for sequencing the punch to penetrate the barrier to release at least one of
5 the penetrating members from a sterile environment;
6 a penetrating member gripper coupled to a penetrating member driver, wherein
7 the penetrating member gripper is elastically movable to apply frictional force to the penetrating
8 member.

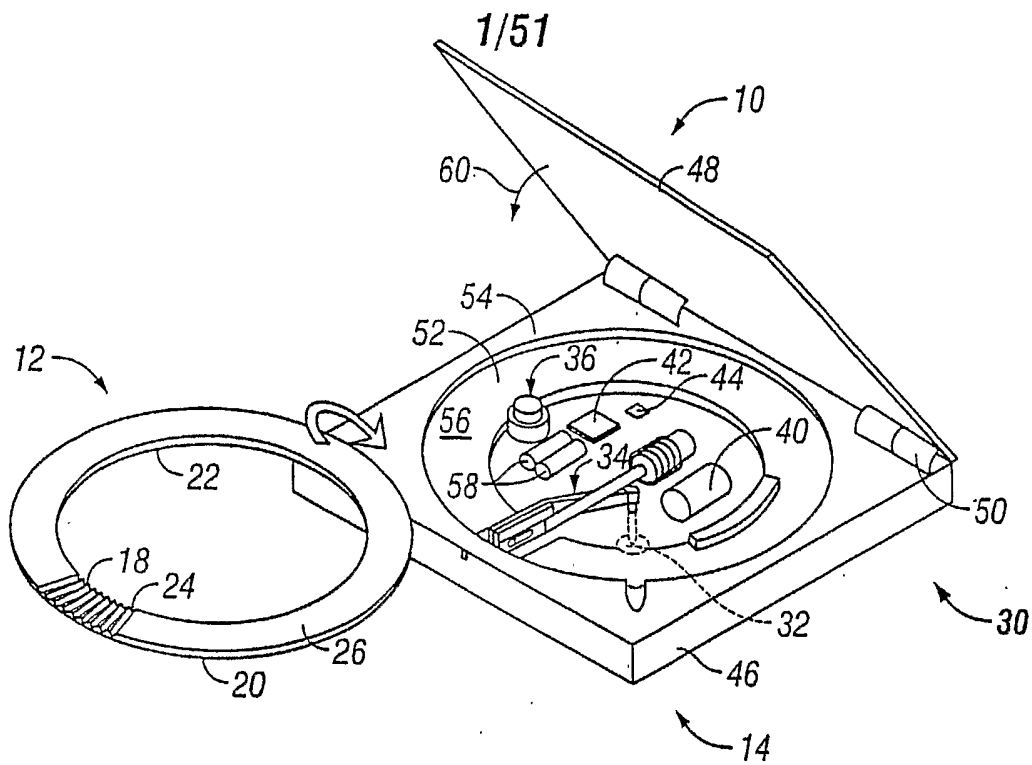

FIG. 1

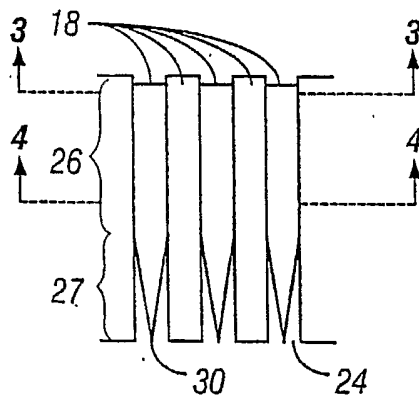

FIG. 2

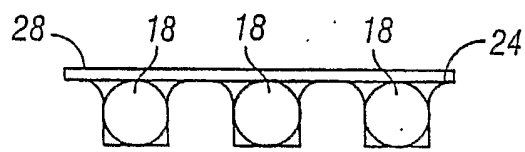

FIG. 3

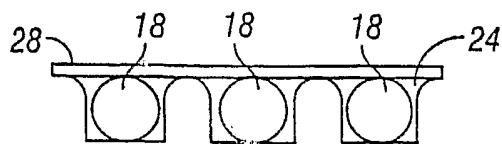

FIG. 4

2/51

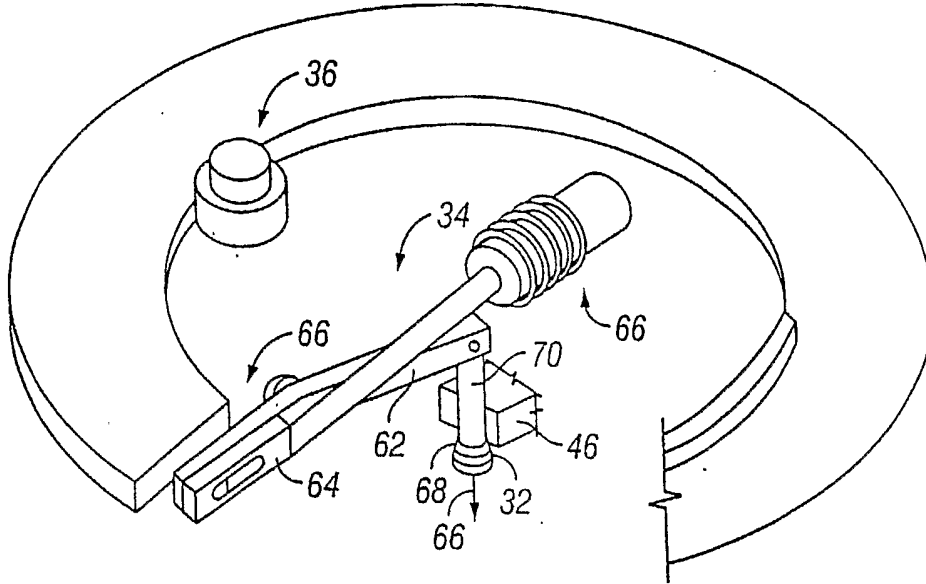

FIG. 5

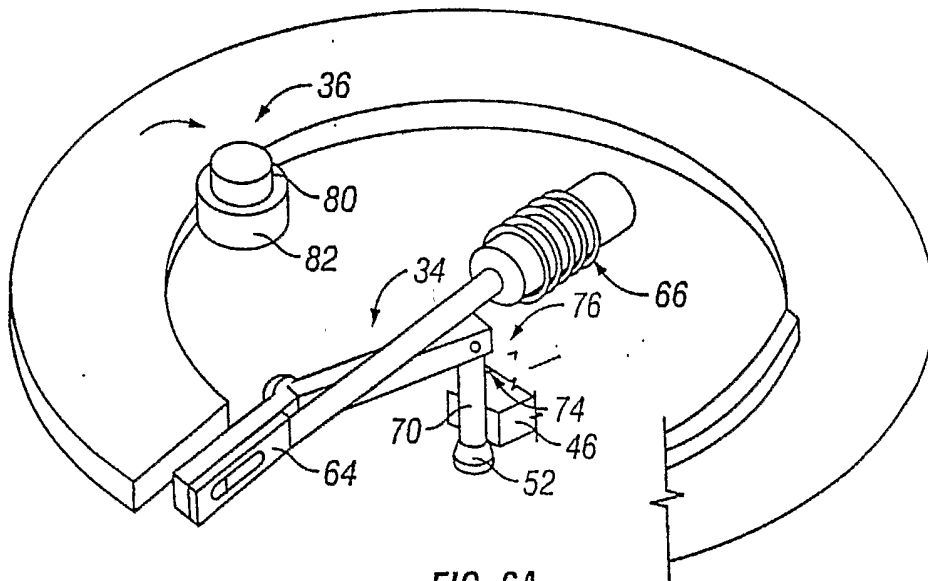

FIG. 6A

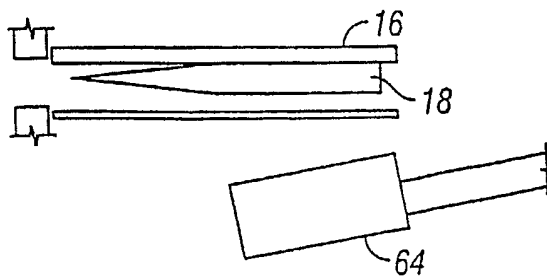

FIG. 6B

3/51

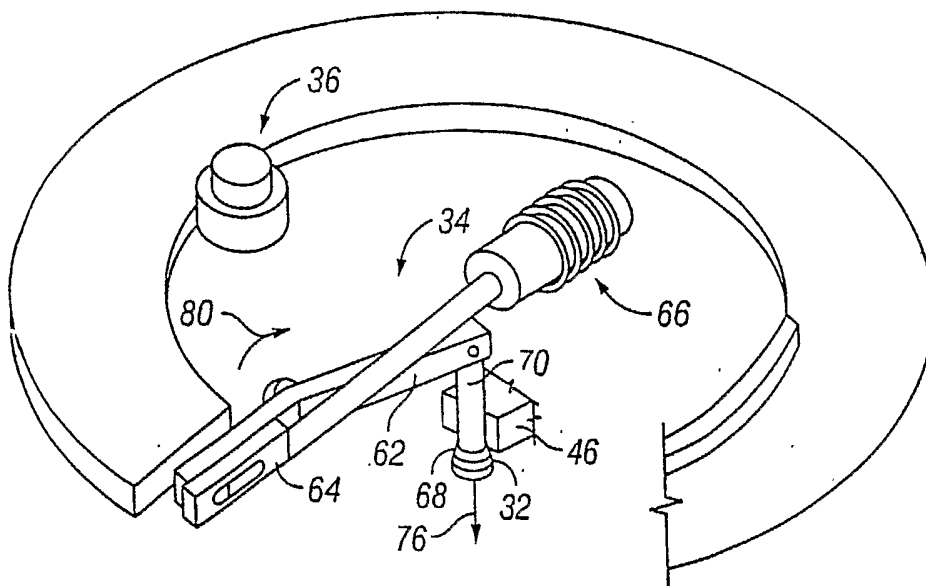
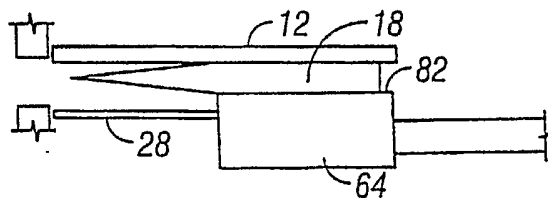

FIG. 7A



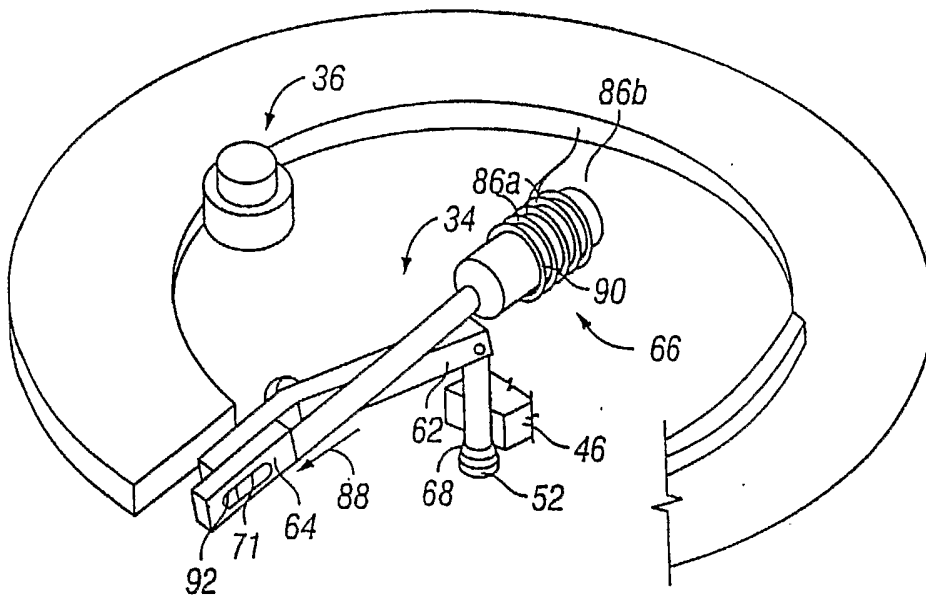

FIG. 8A

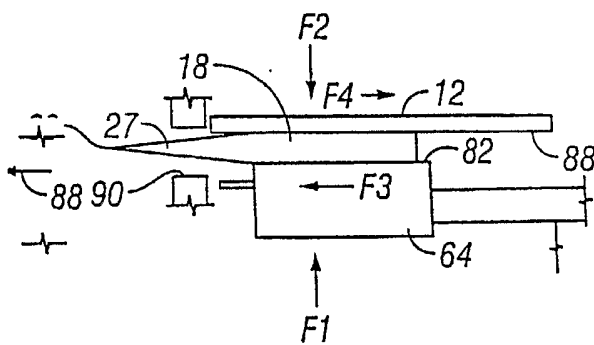

FIG. 8B

5/51

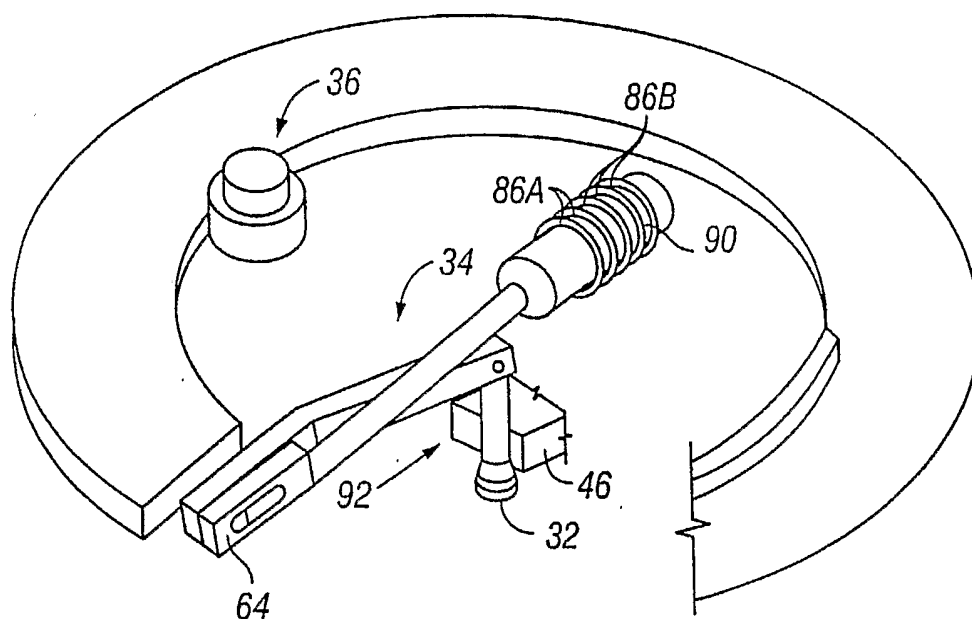

FIG. 9A

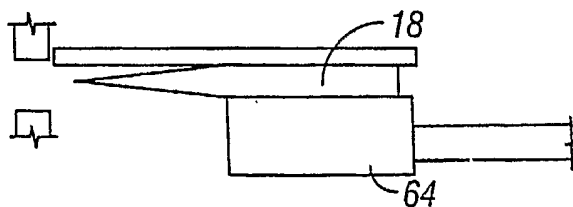

FIG. 9B

6/51

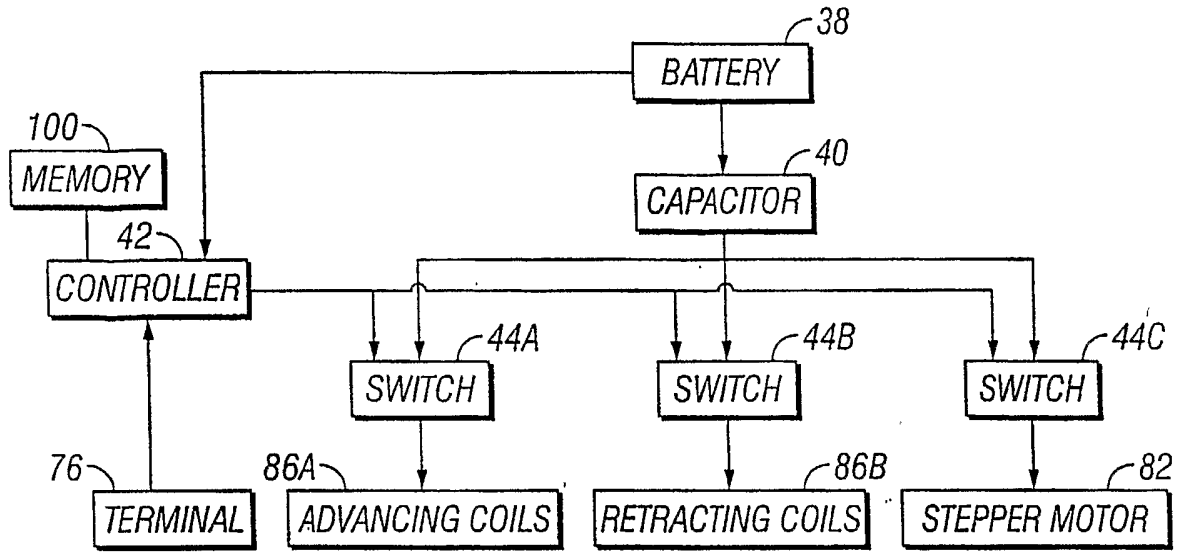

FIG. 10

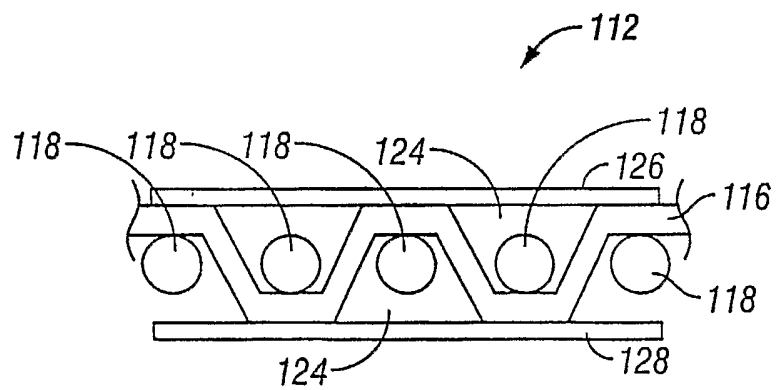

FIG. 11

7/51

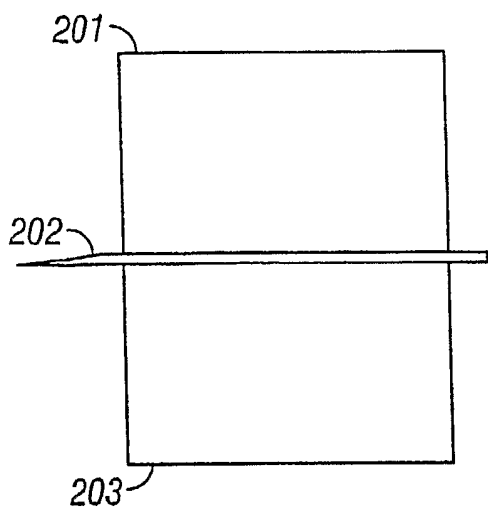

FIG. 12

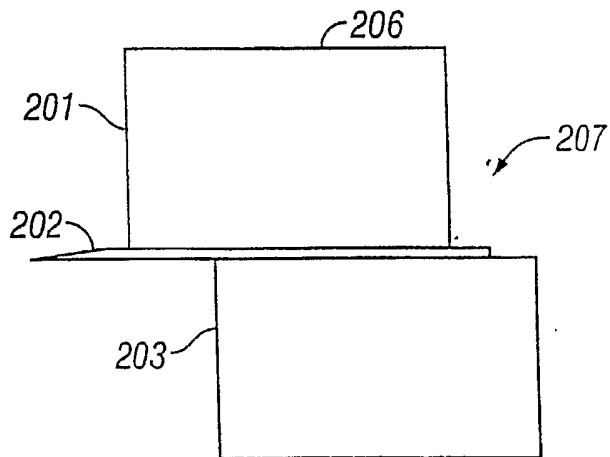

FIG. 13

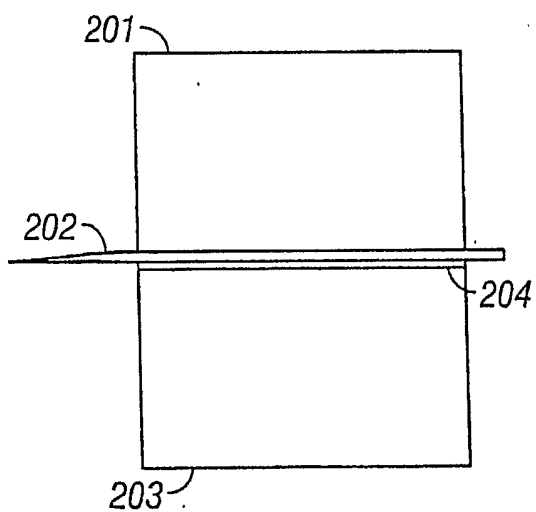

FIG. 14

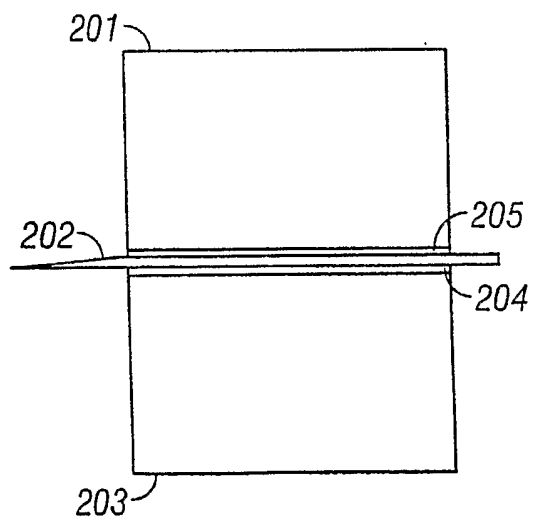

FIG. 15

8/51

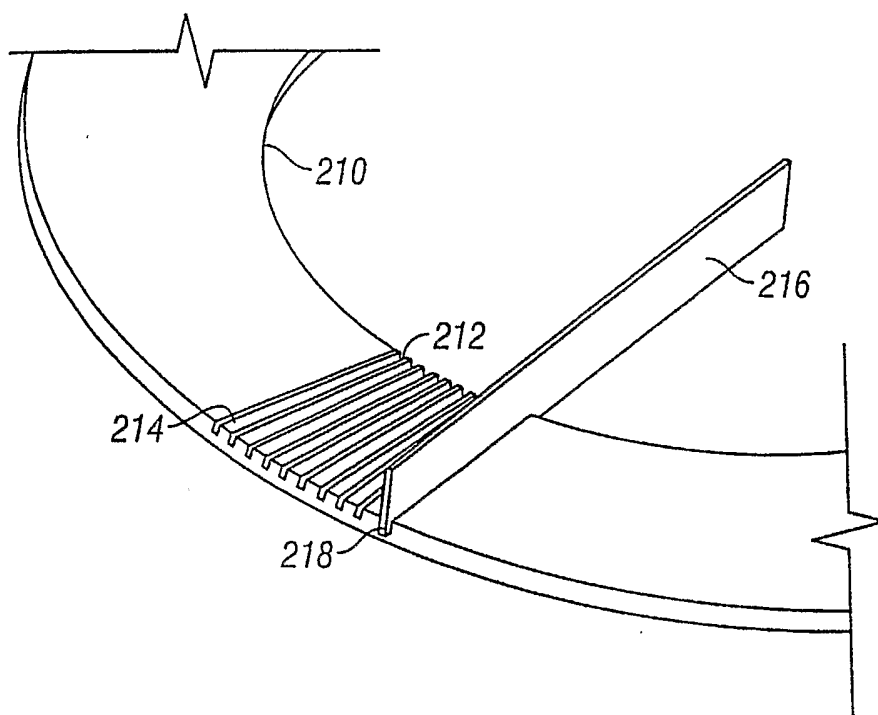

FIG. 16

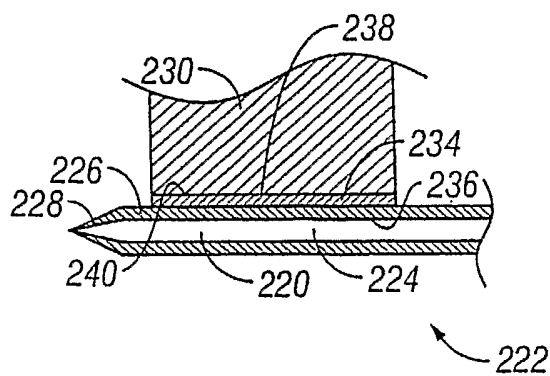

FIG. 17

9/51

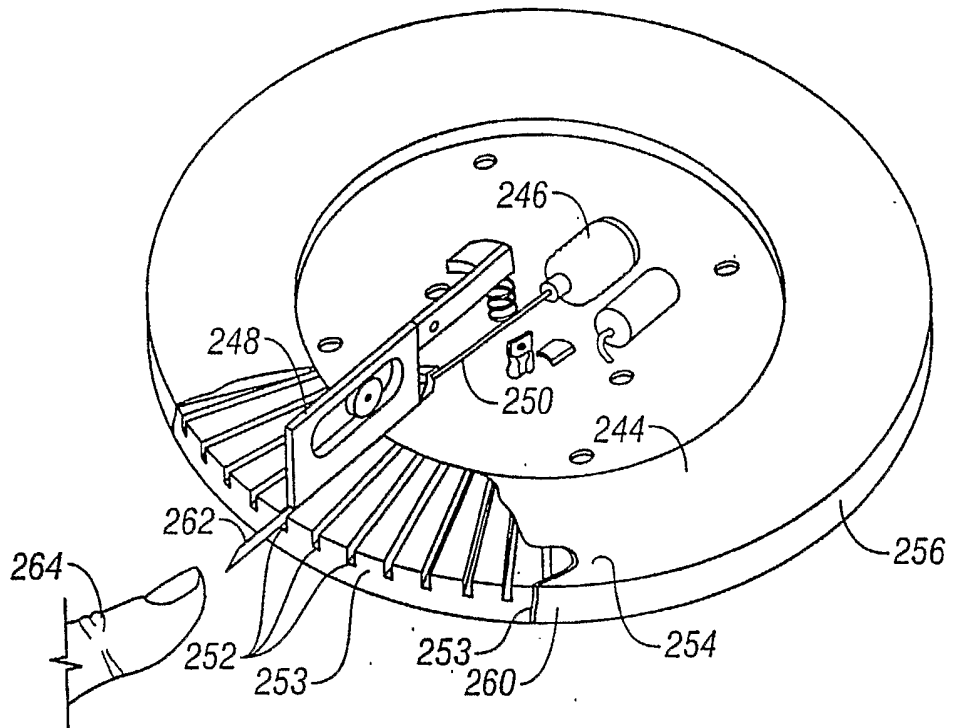

FIG. 18

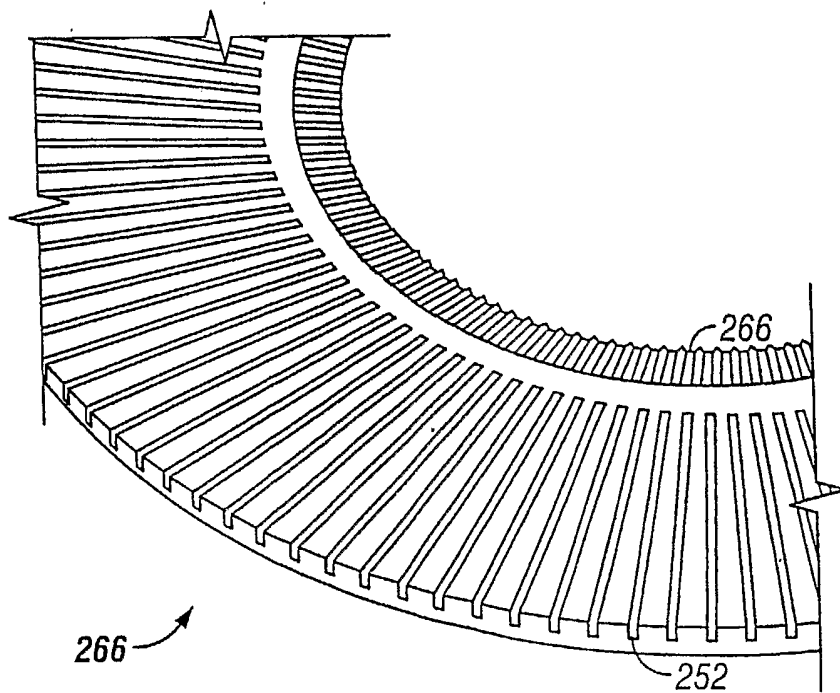

FIG. 19
SUBSTITUTE SHEET (RULE 26)

10/51

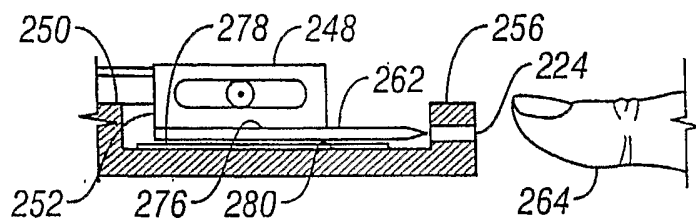

FIG. 20

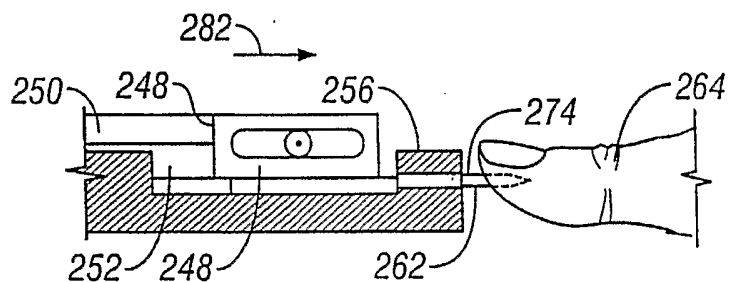

FIG. 21

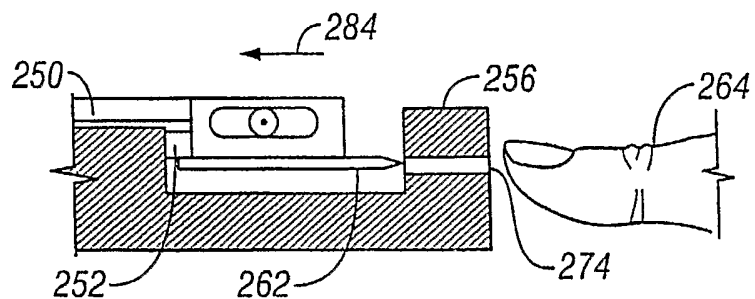

FIG. 22

11/51

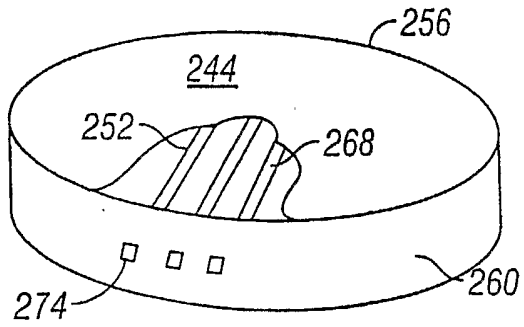

FIG. 23

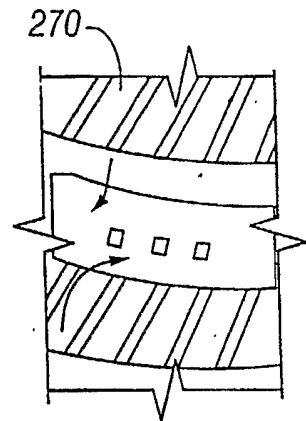

FIG. 24

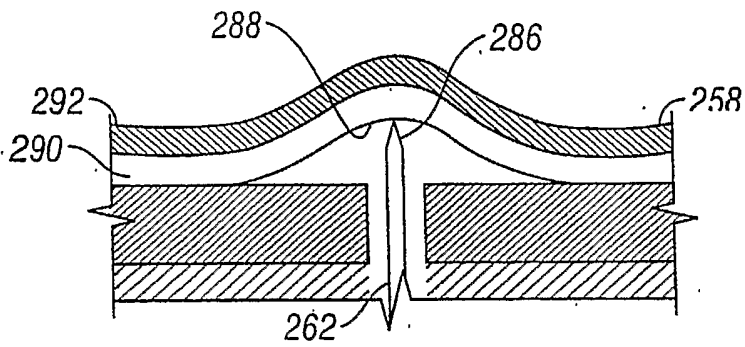

FIG. 25

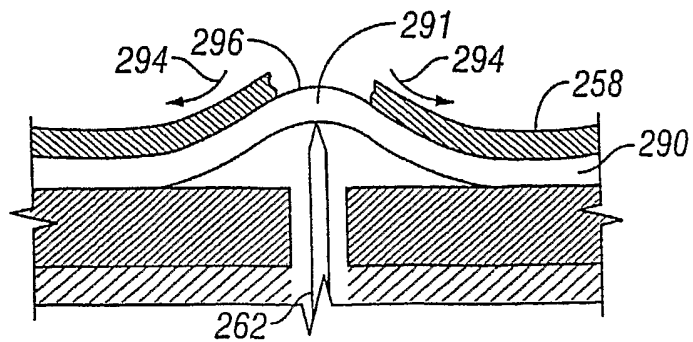

FIG. 26

12/51

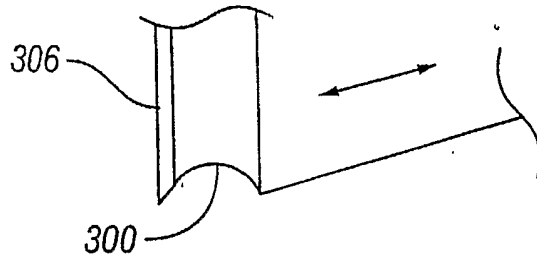

FIG. 27

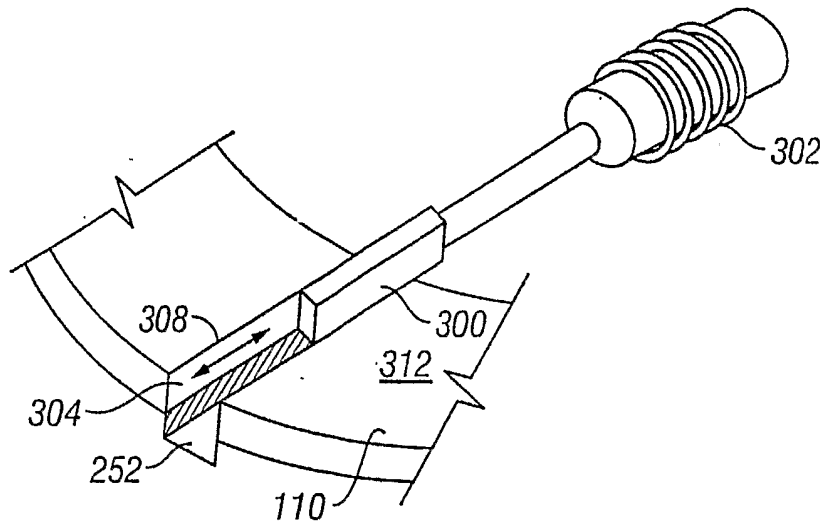

FIG. 28



FIG. 29

13/51

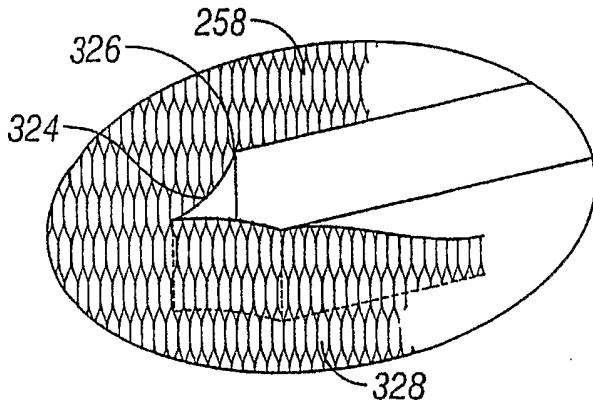

FIG. 30

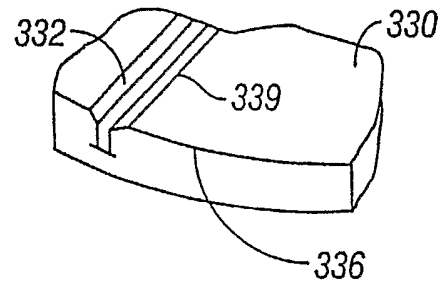

FIG. 31

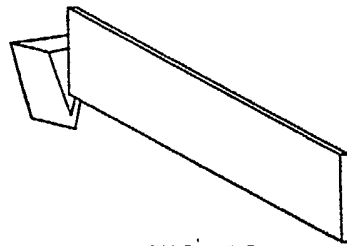

FIG. 32

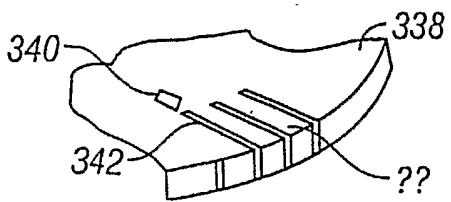

FIG. 33

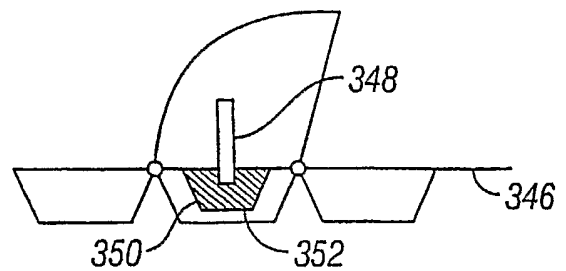

FIG. 34

14/51

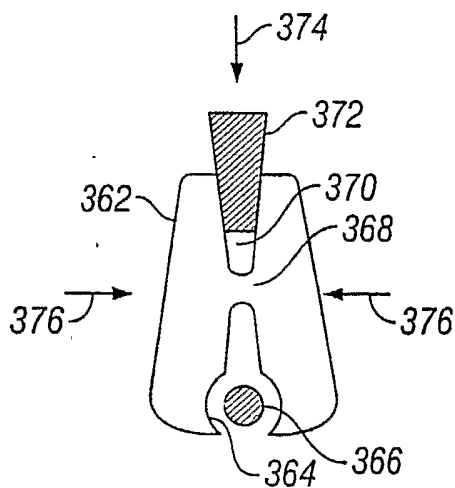

FIG. 35

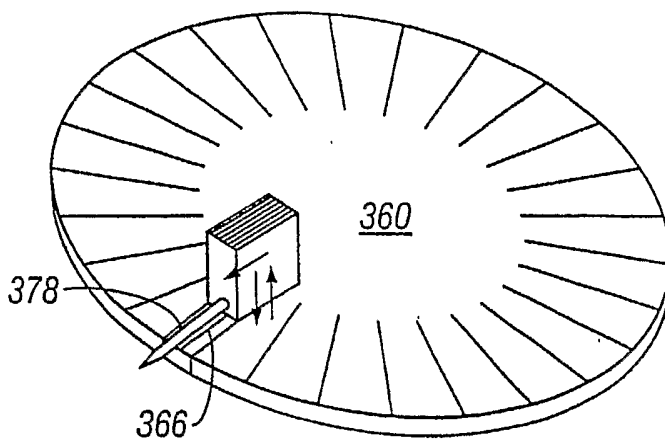

FIG. 36

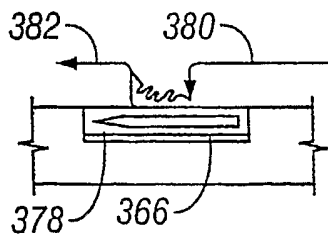

FIG. 37

15/51

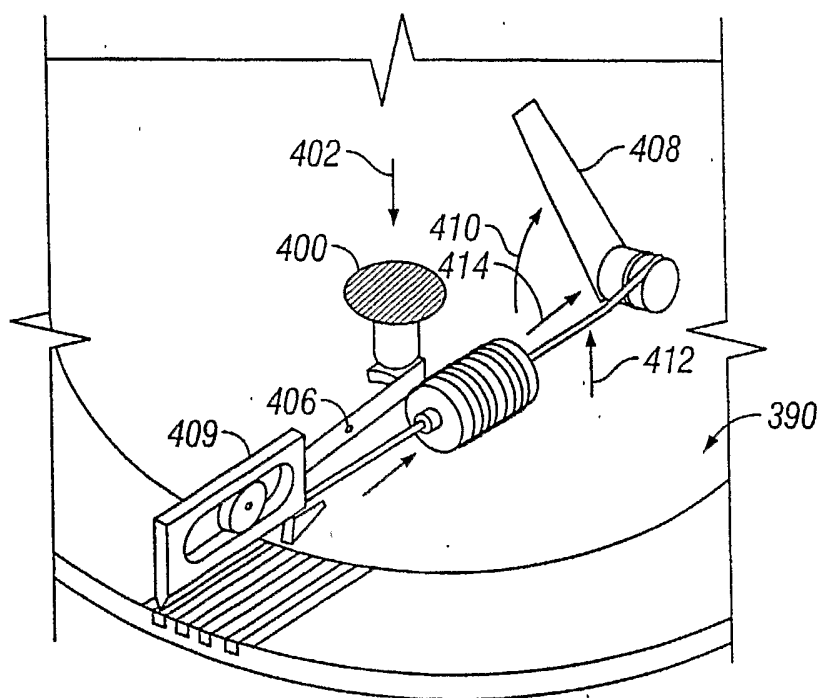

FIG. 38

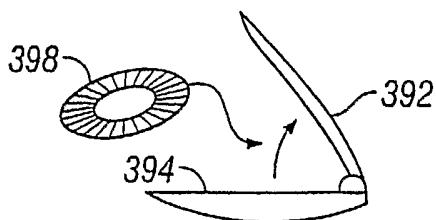

FIG. 39

16/51

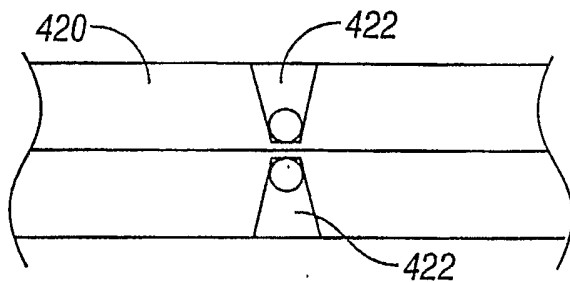

FIG. 40

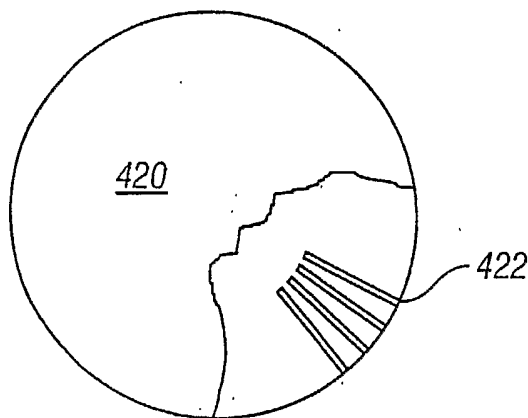

FIG. 41

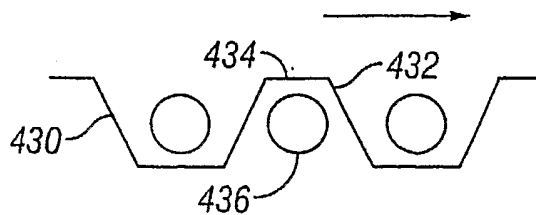

FIG. 42

17/51

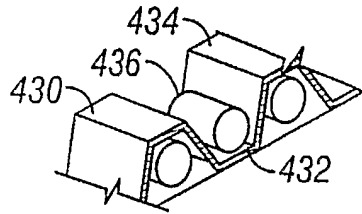

FIG. 43

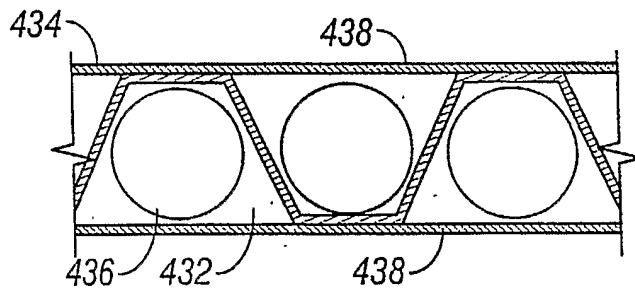

FIG. 44

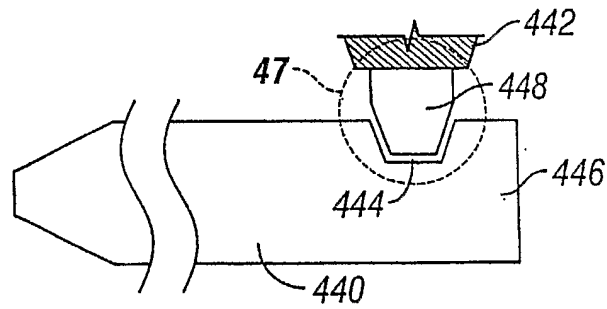

FIG. 45

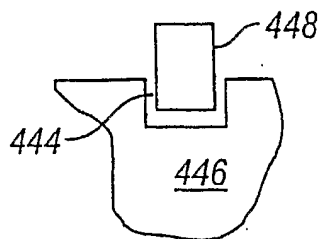

FIG. 46

18/51

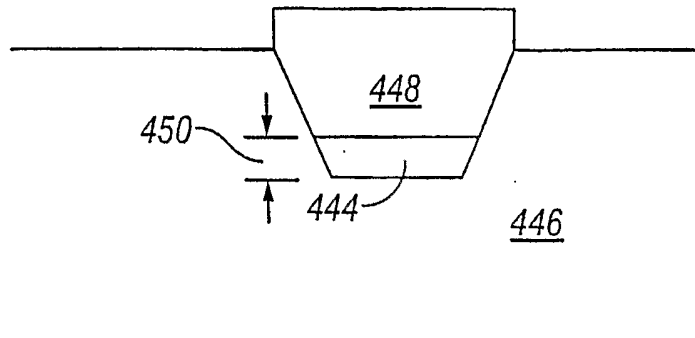

FIG. 47

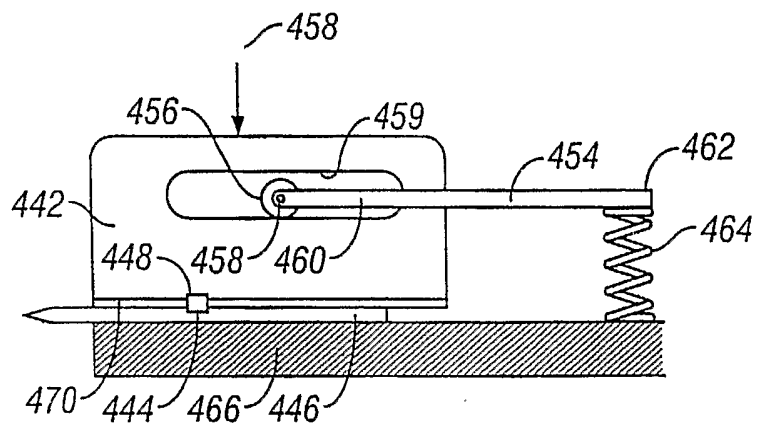

FIG. 48

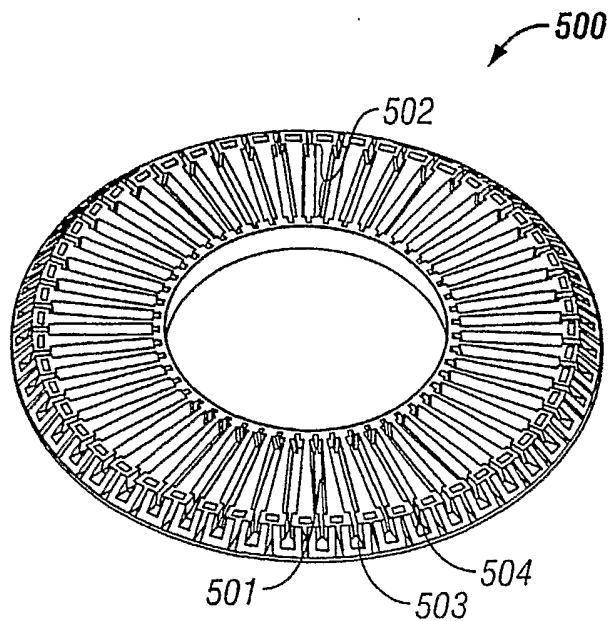

FIG. 49

19/51

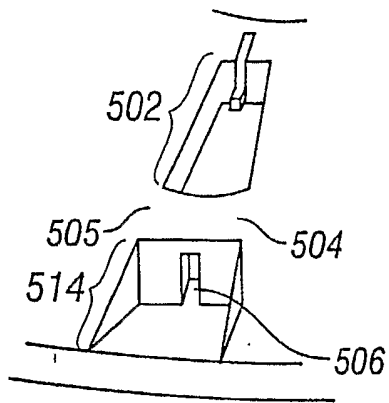

FIG. 50

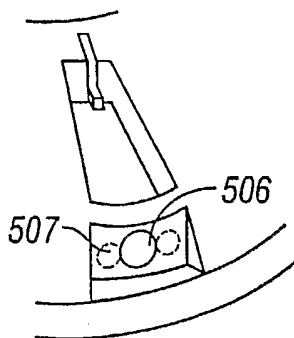

FIG. 51

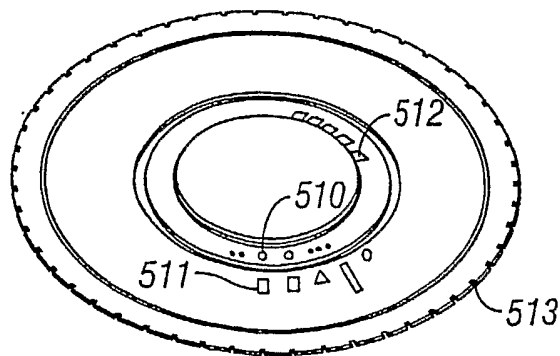

FIG. 52

20/51

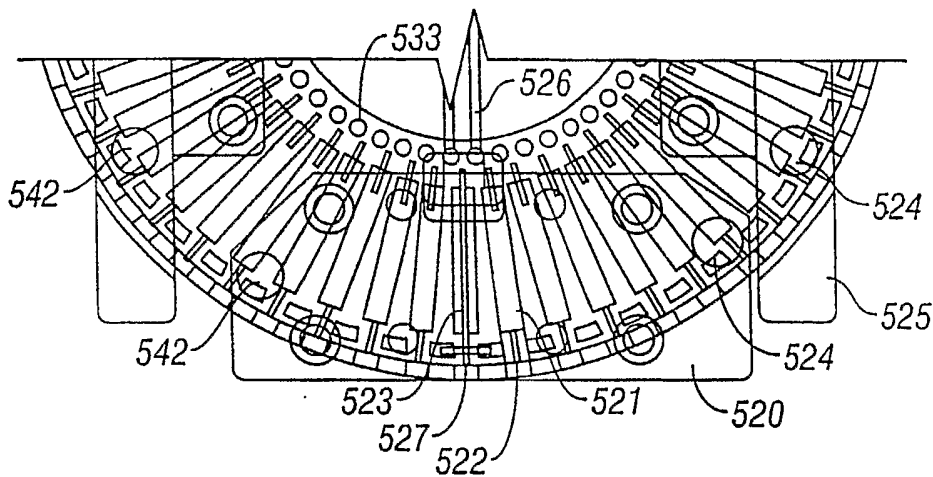

FIG. 53A

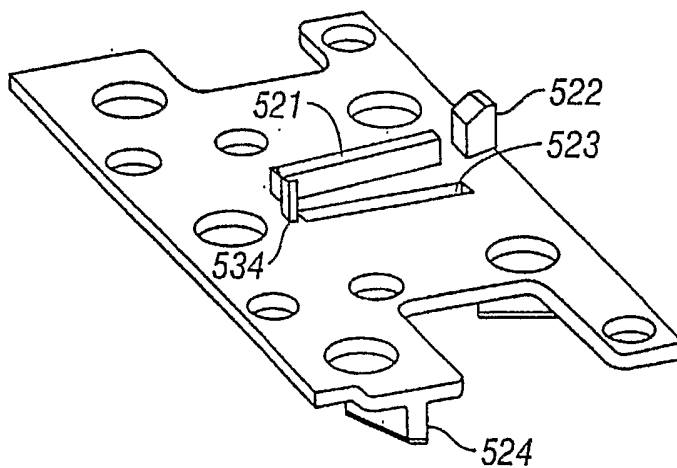

FIG. 53B

21/51

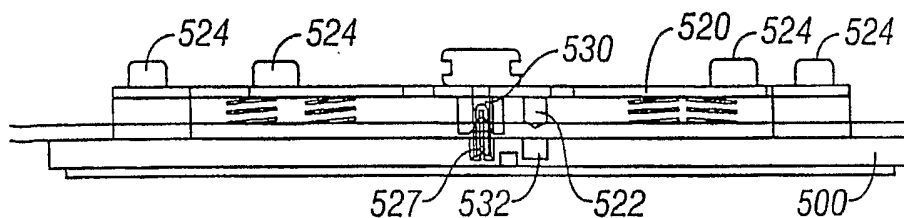

FIG. 54A

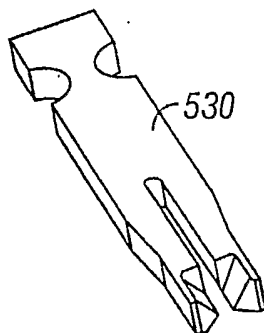

FIG. 54B

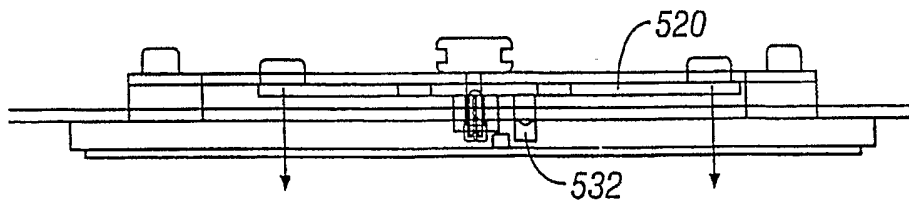

FIG. 54C

22/51

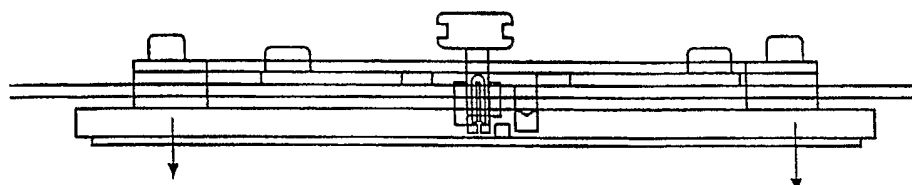

FIG. 54D

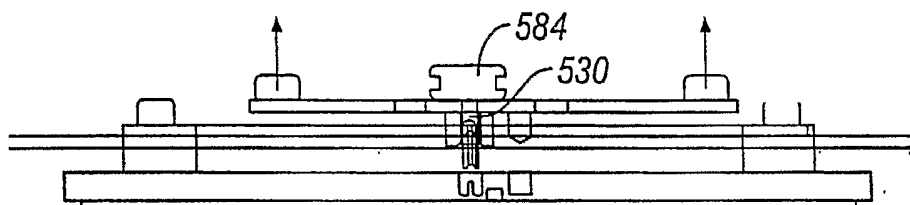

FIG. 54E

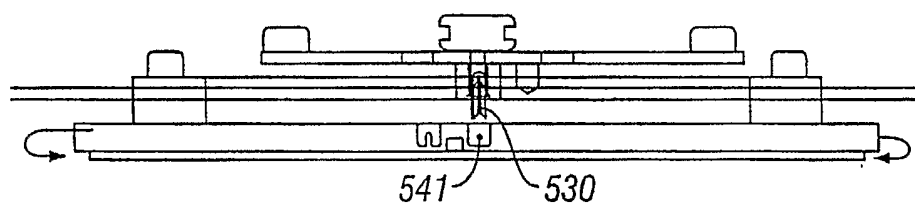

FIG. 54F

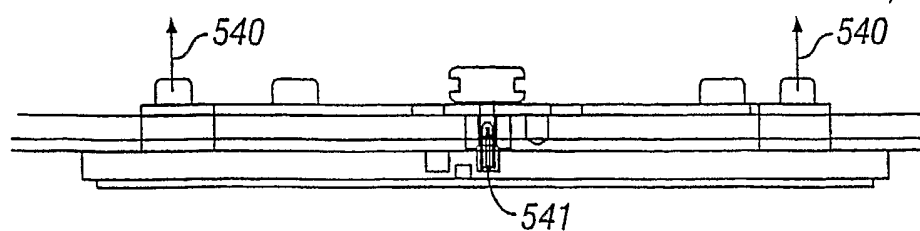

FIG. 54G

23/51

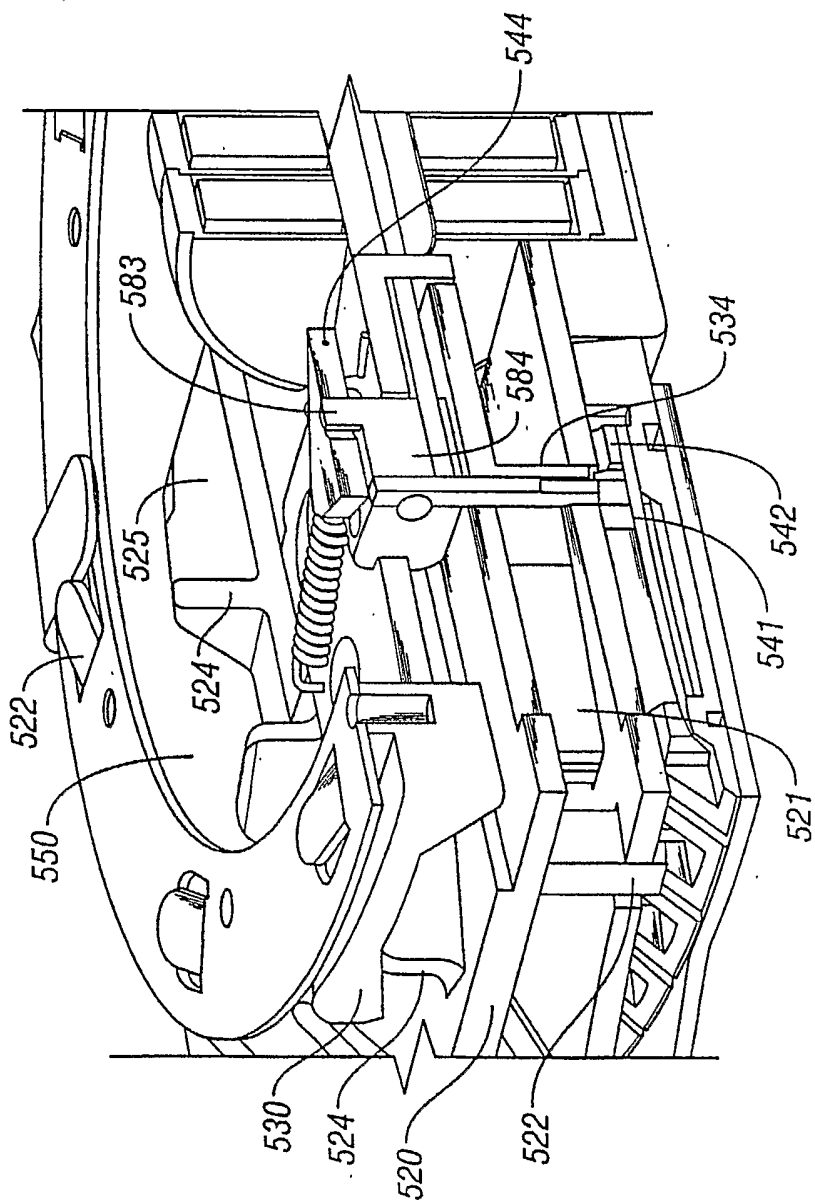

FIG. 55A

24/51

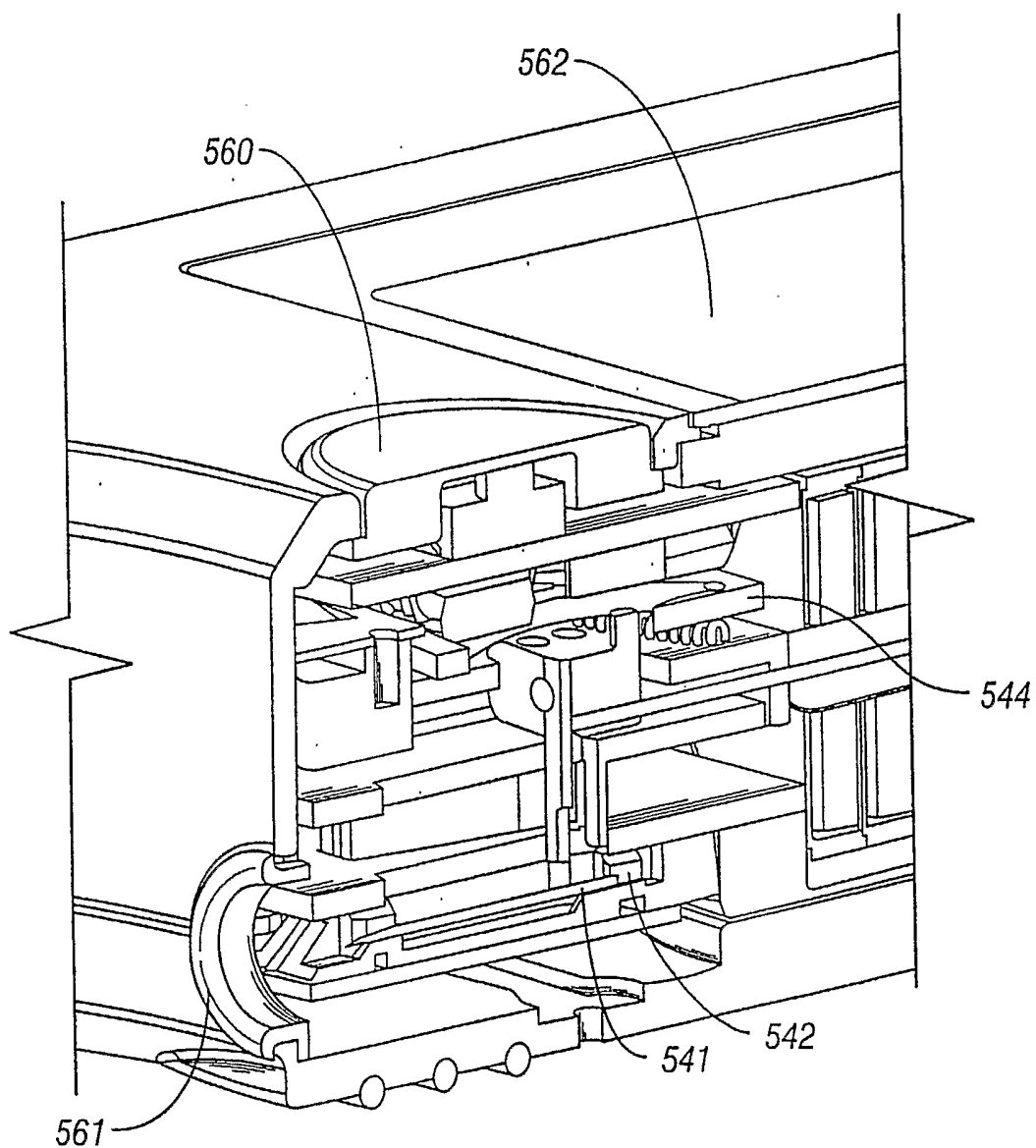

FIG. 55B

25/51

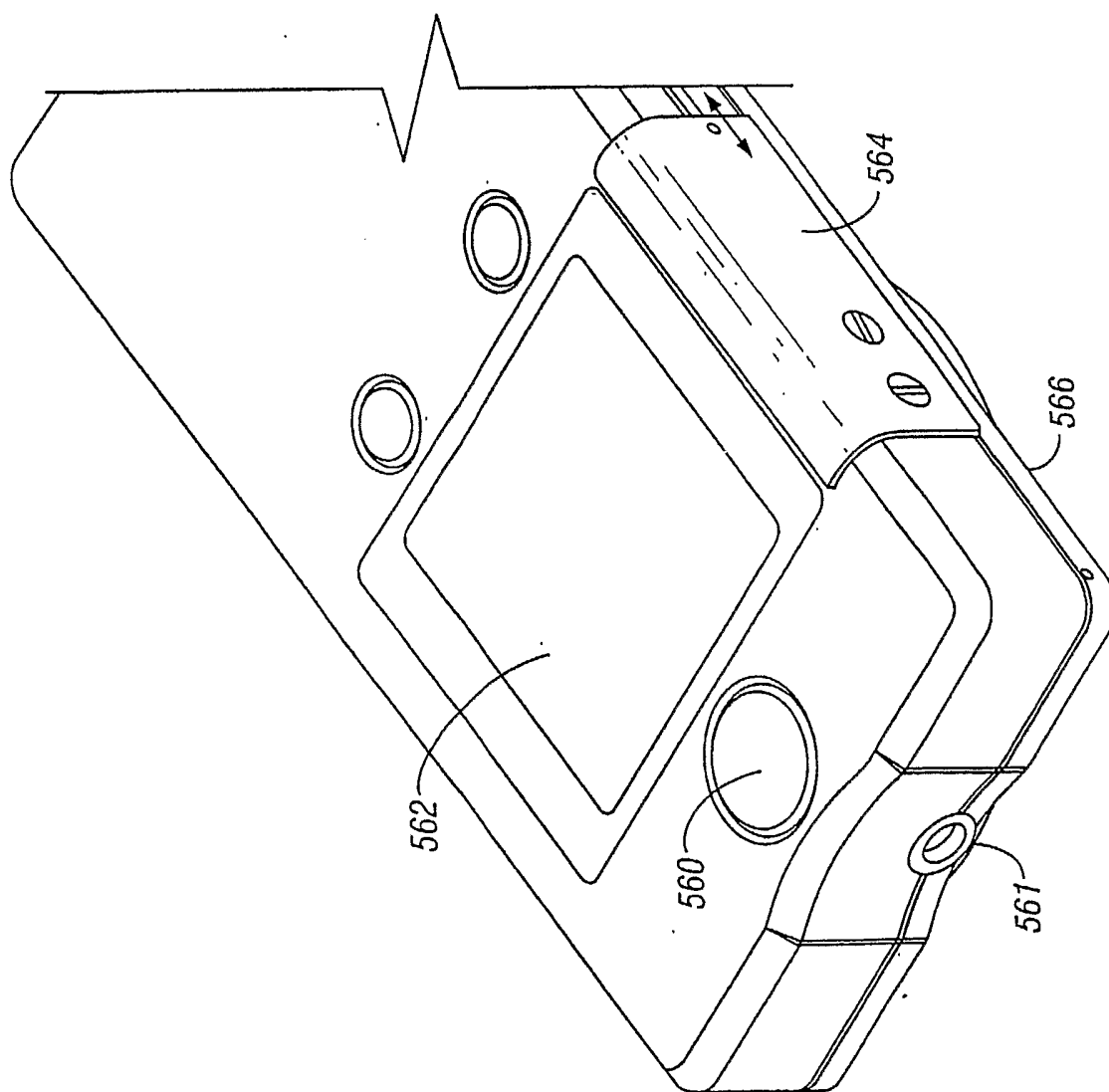

FIG. 56A

26/51

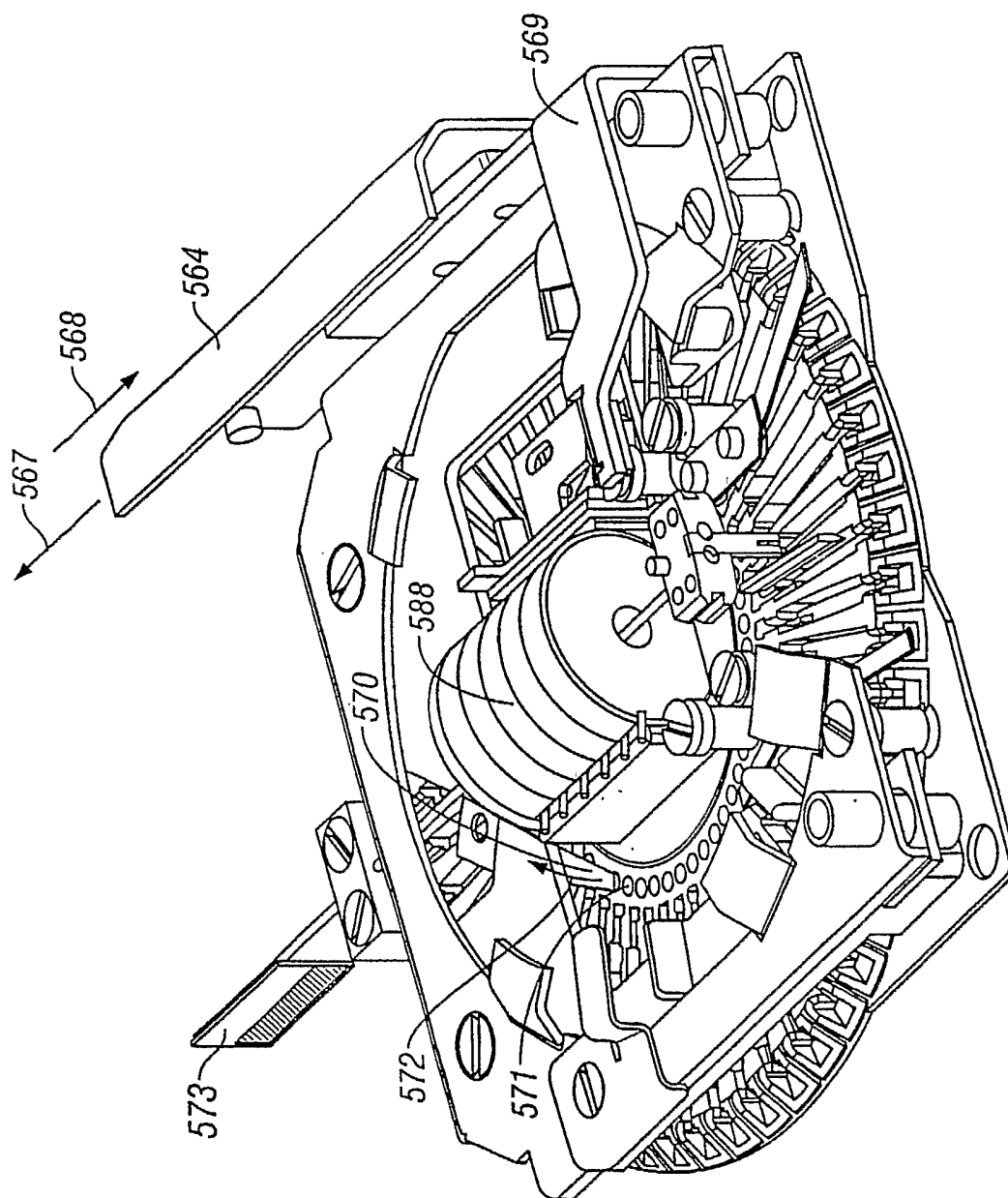

FIG. 56B

27/51

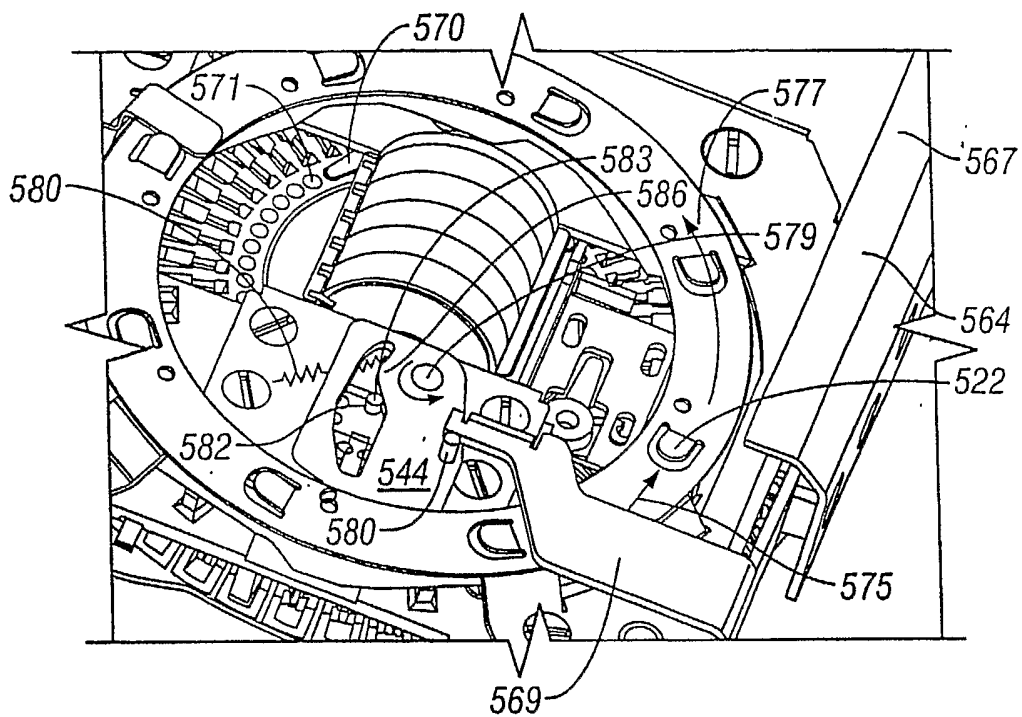

FIG. 56C

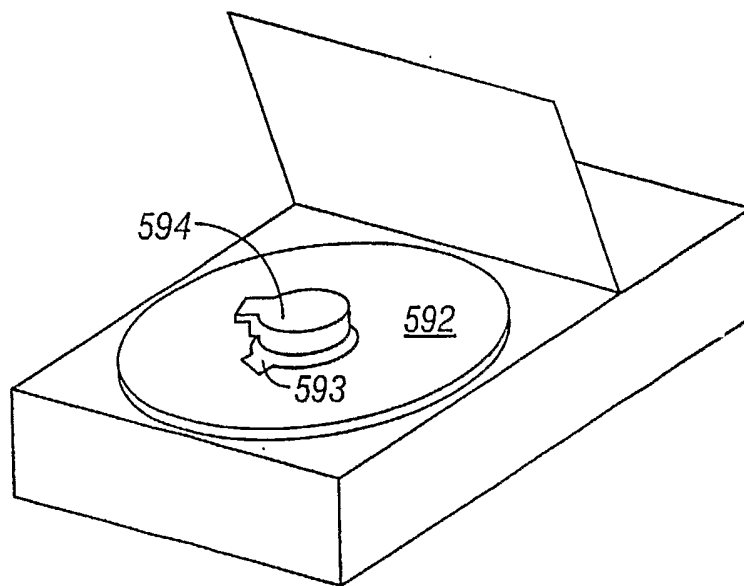

FIG. 56D

28/51

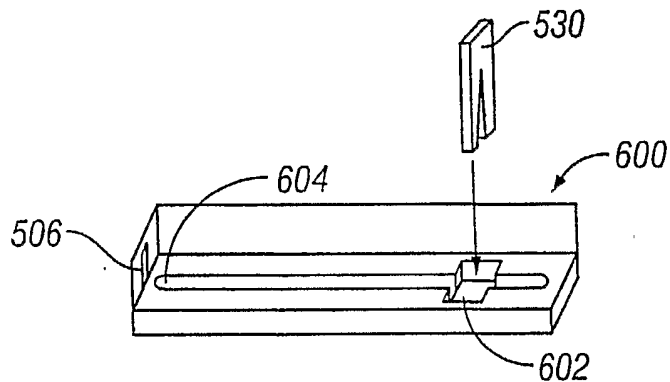

FIG. 57

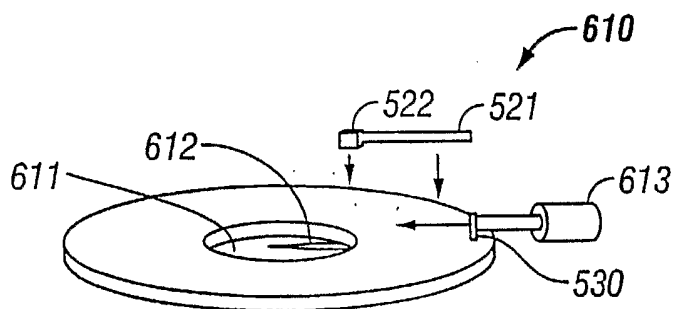

FIG. 58

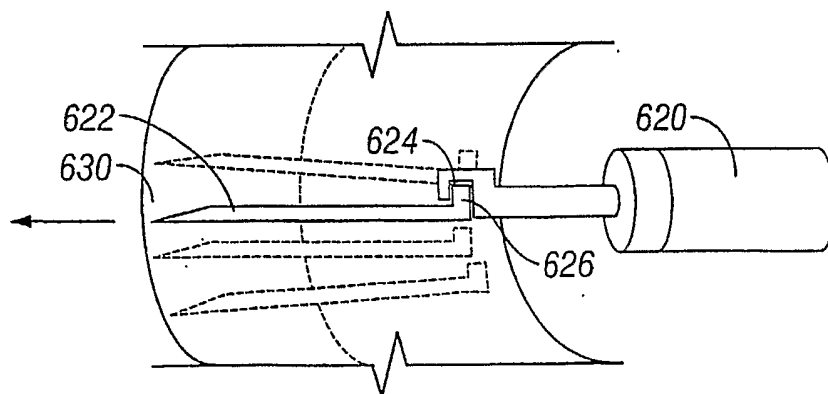

FIG. 59

29/51

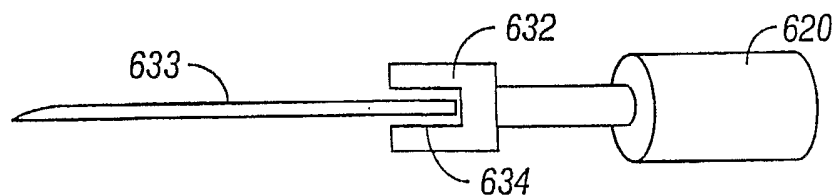

FIG. 60A

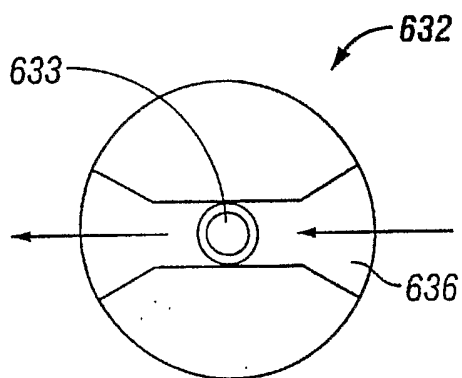

FIG. 60B

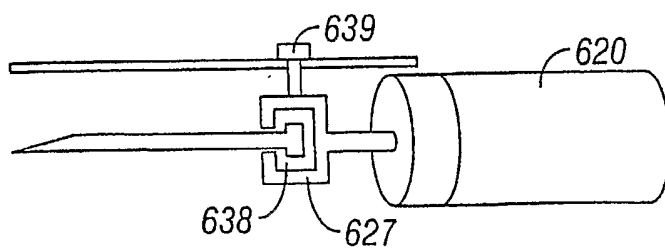

FIG. 60C

30/51

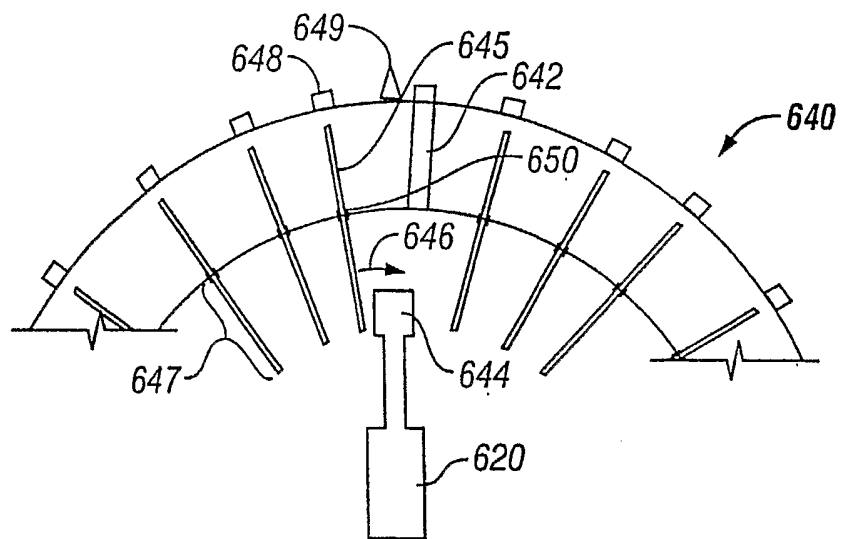

FIG. 61

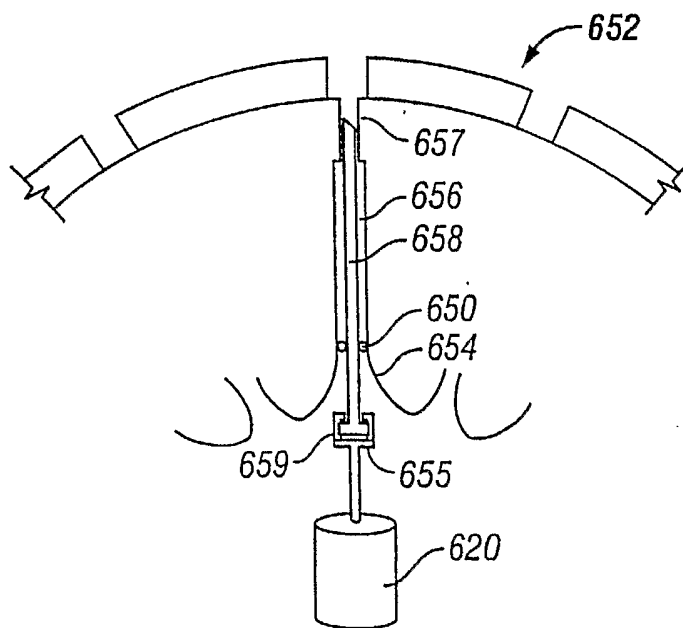

FIG. 62

31/51

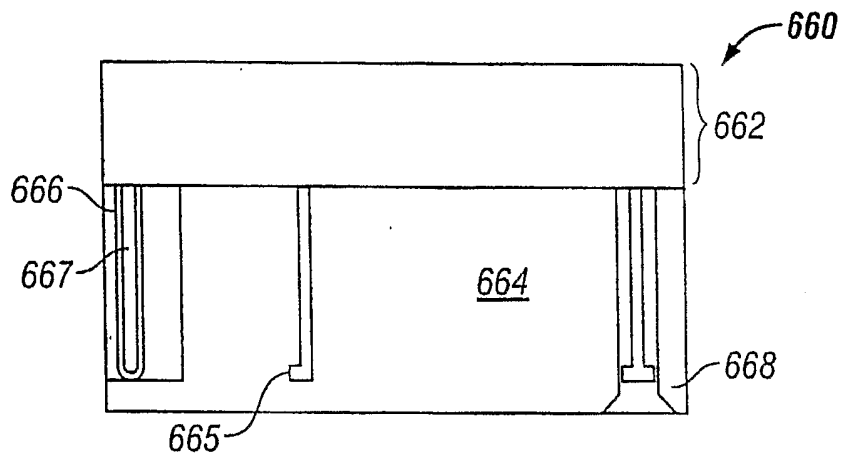

FIG. 63

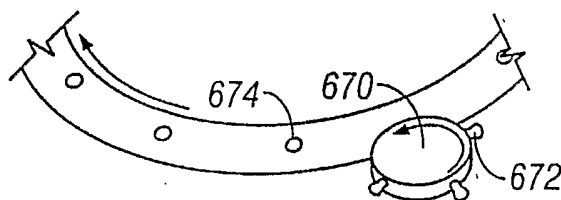

FIG. 64A

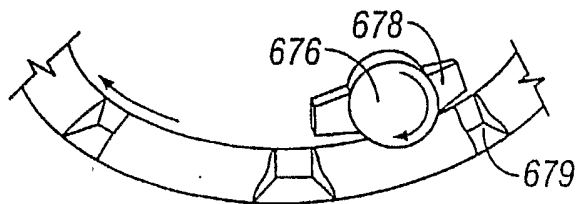

FIG. 64B

32/51

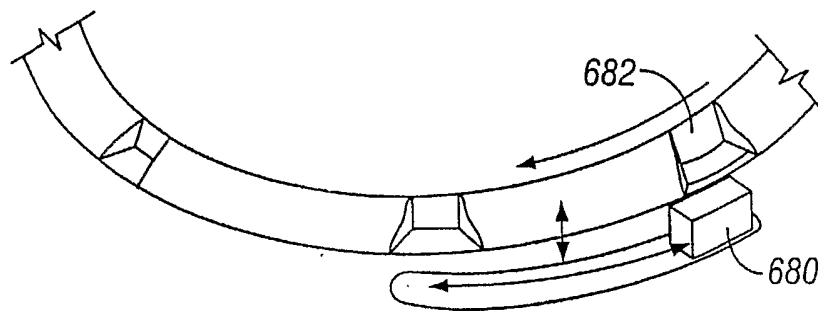

FIG. 64C

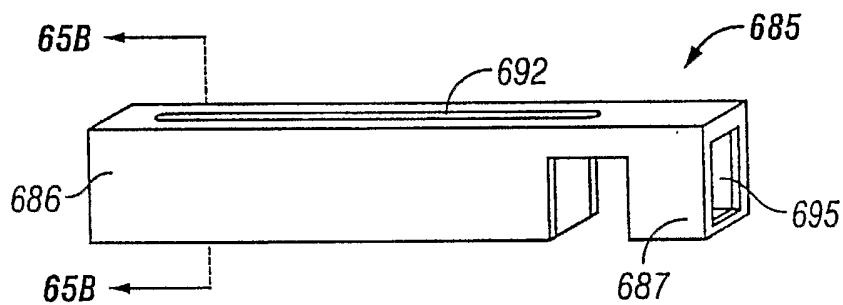

FIG. 65A

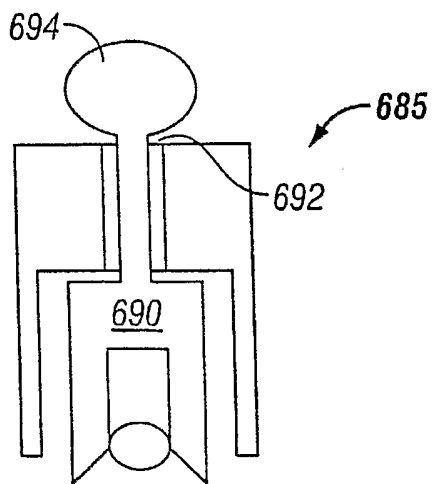

FIG. 65B

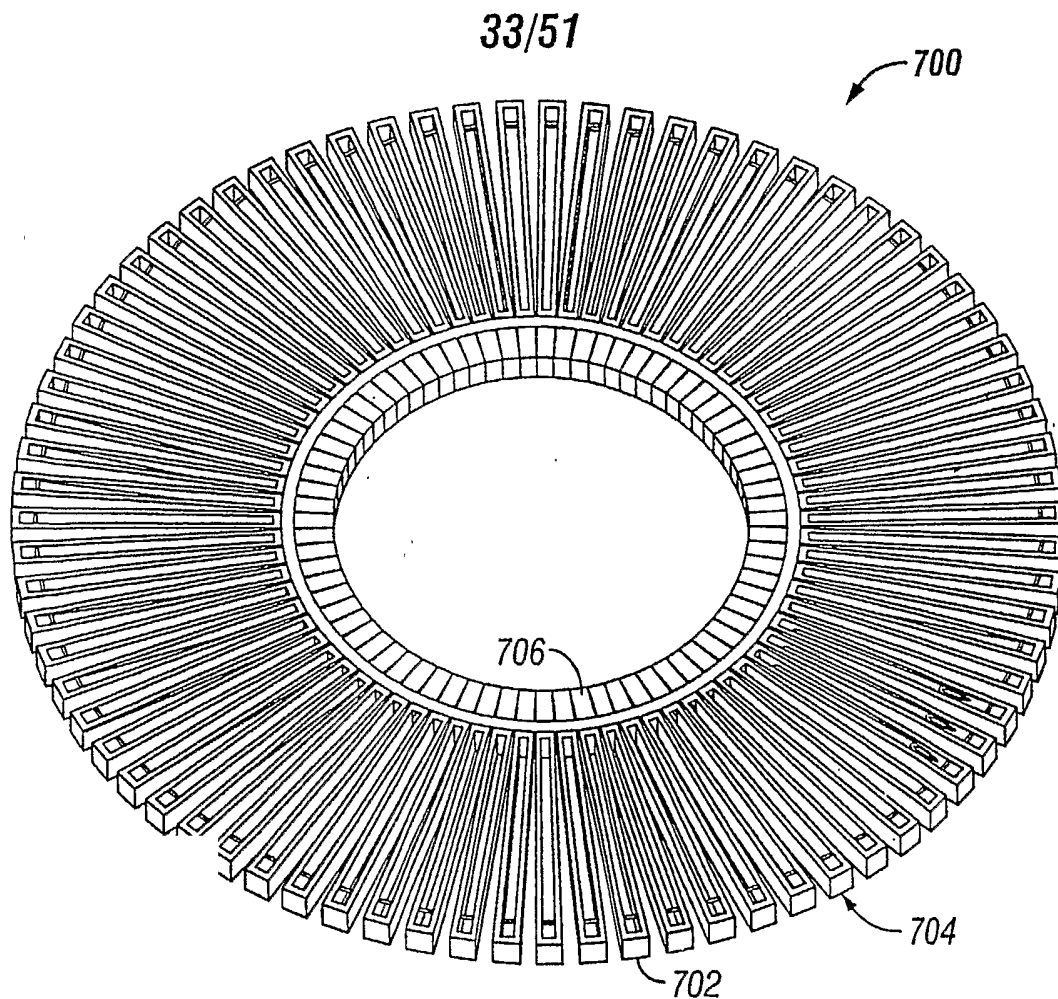
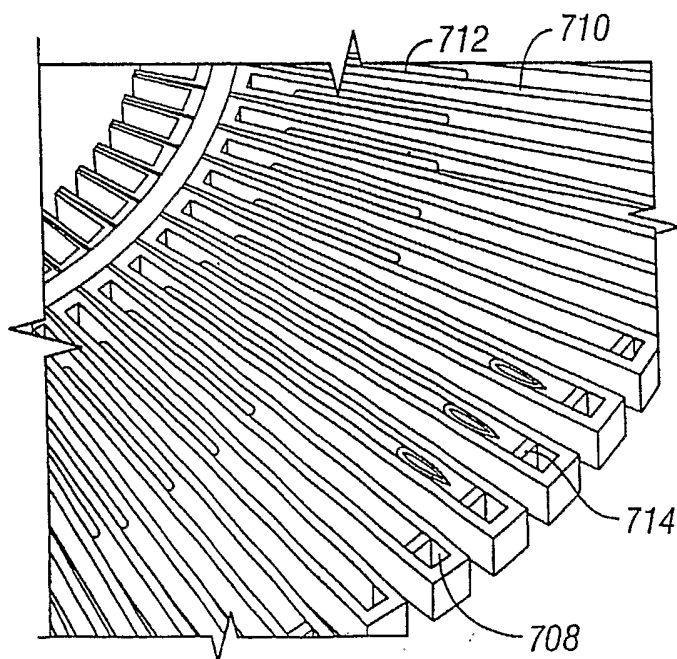

FIG. 66



34/51

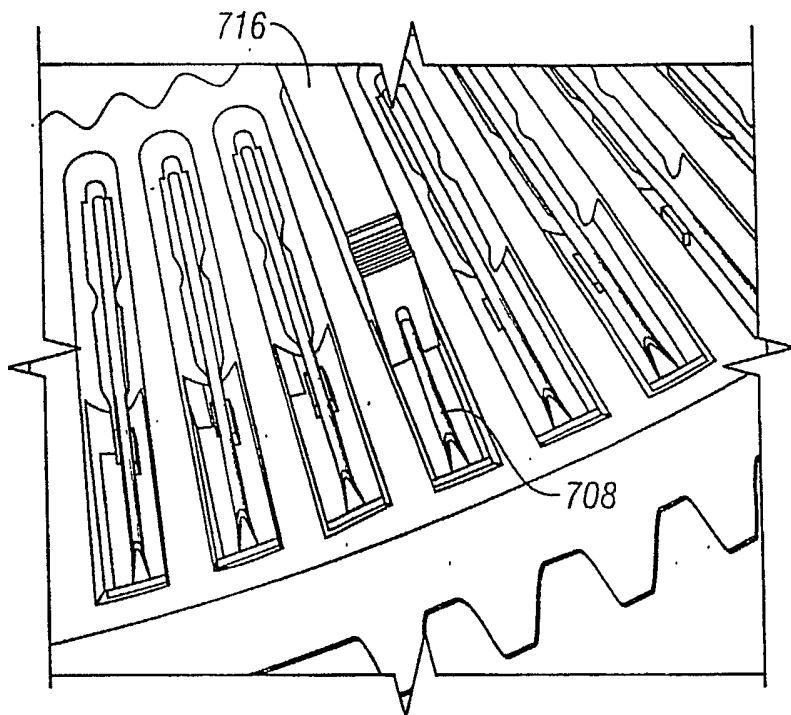

FIG. 68

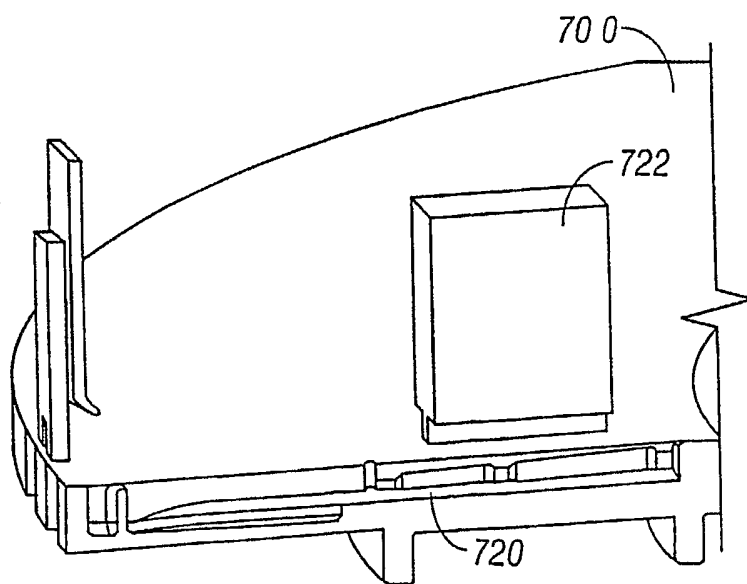

FIG. 69A

35/51

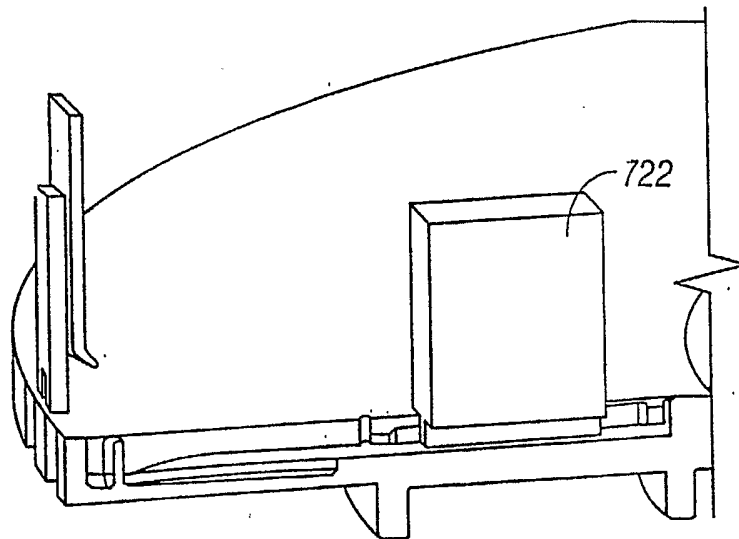

FIG. 69B

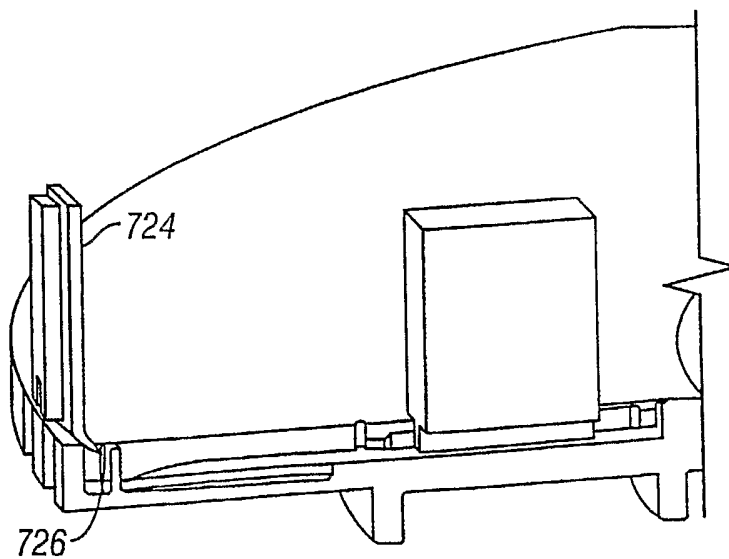

FIG. 69C

36/51

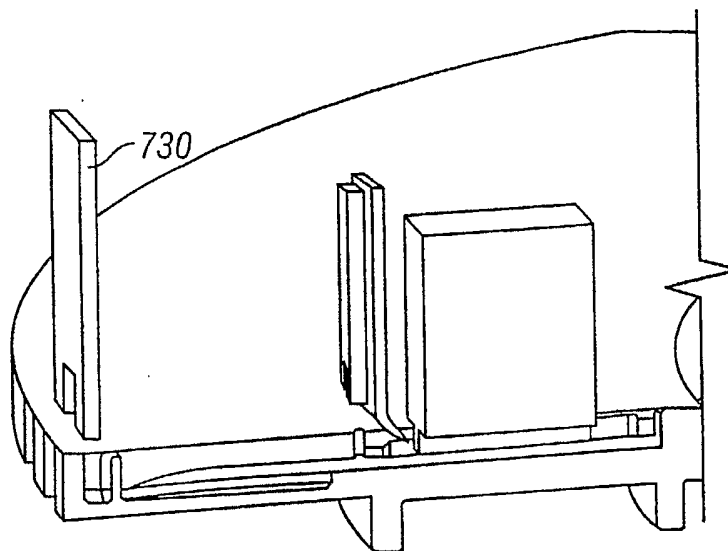

FIG. 69D

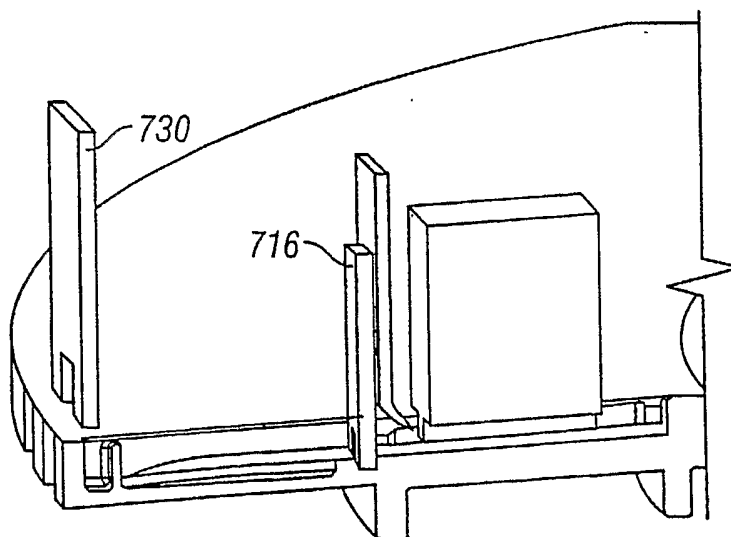

FIG. 69E

37/51

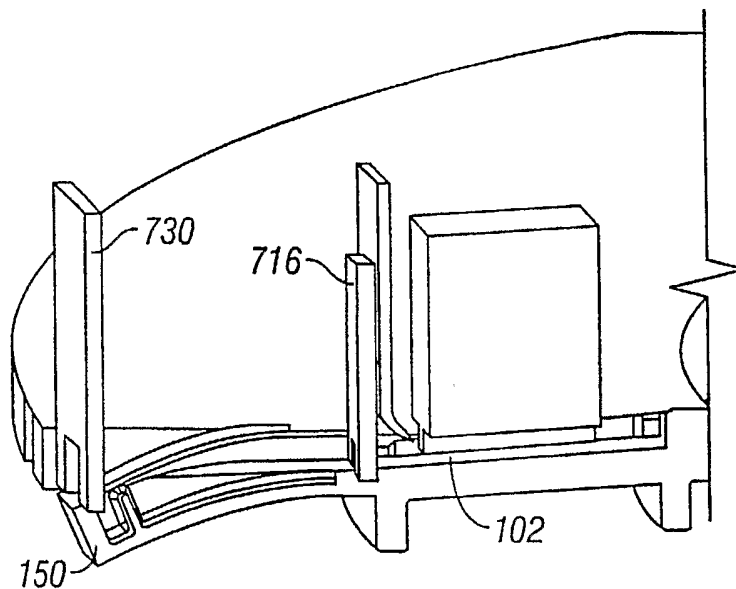

FIG. 69F

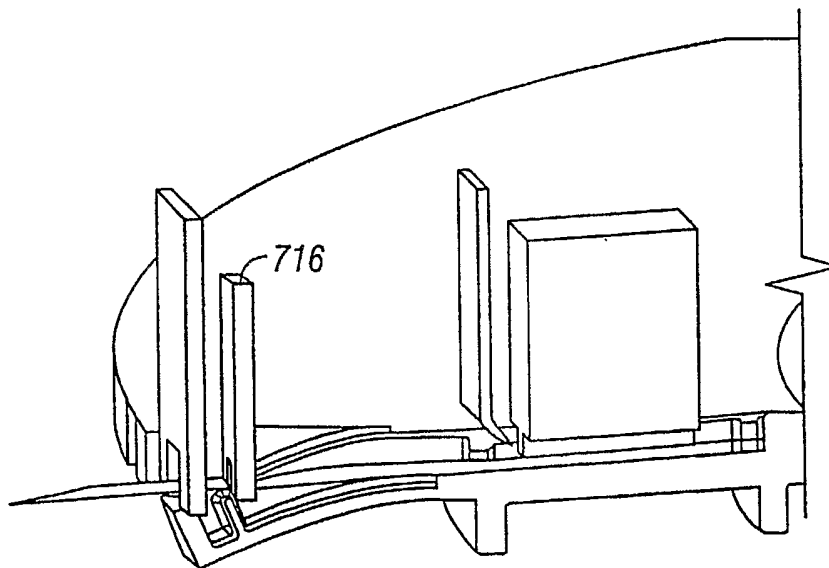

FIG. 69G

38/51

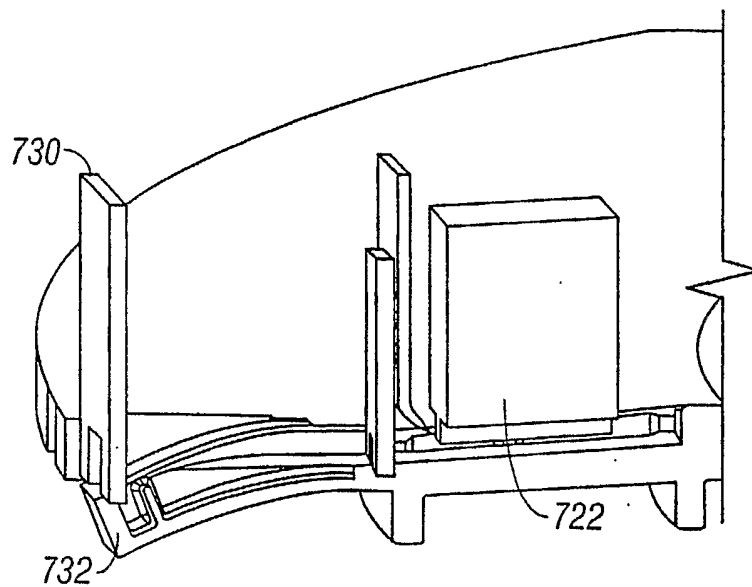

FIG. 69H

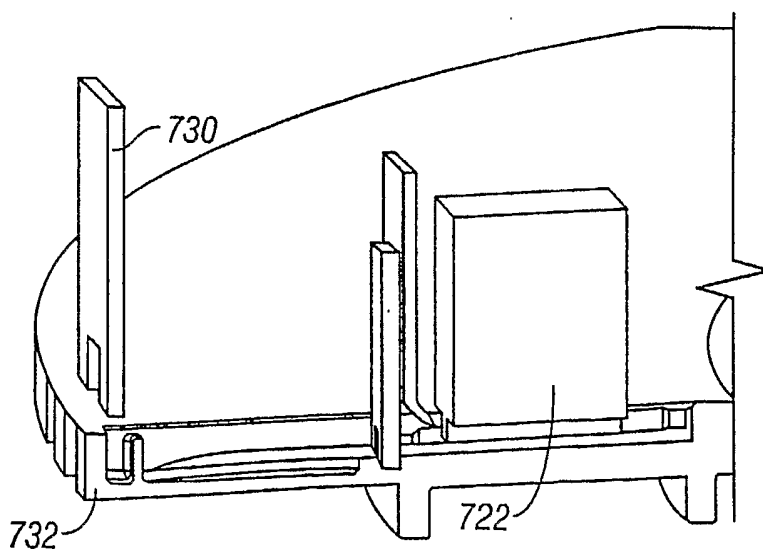

FIG. 69I

39/51

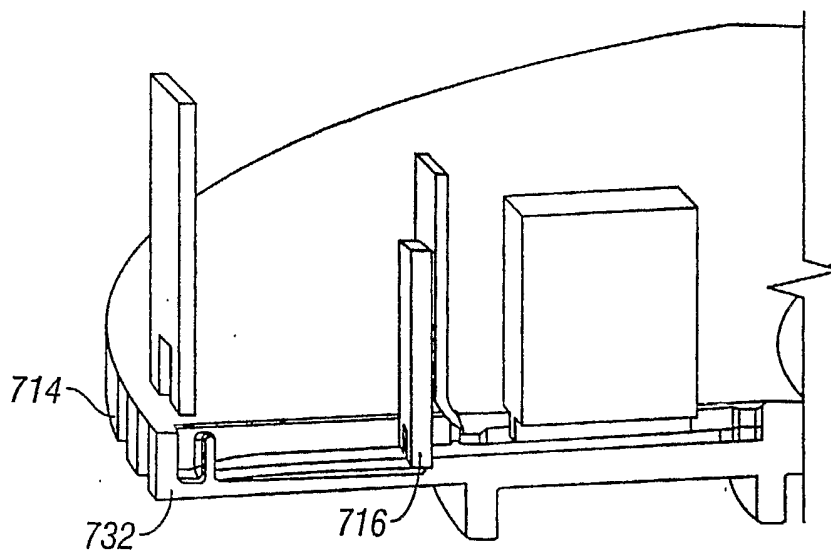

FIG. 69J

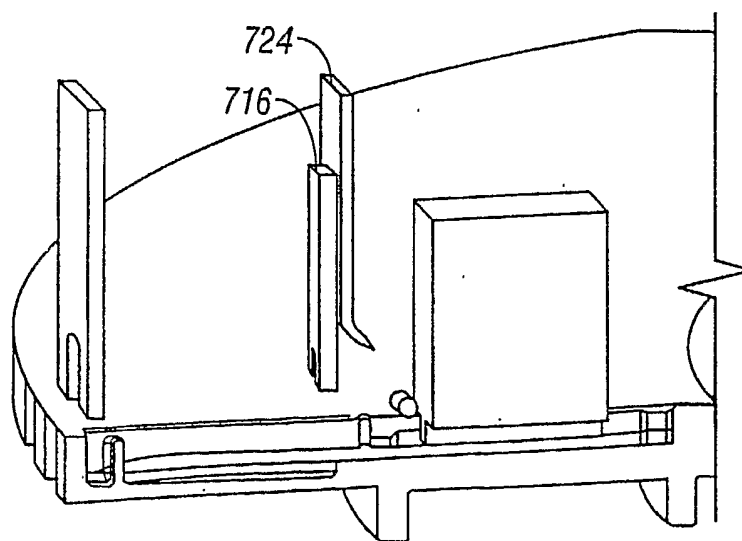

FIG. 69K

40/51

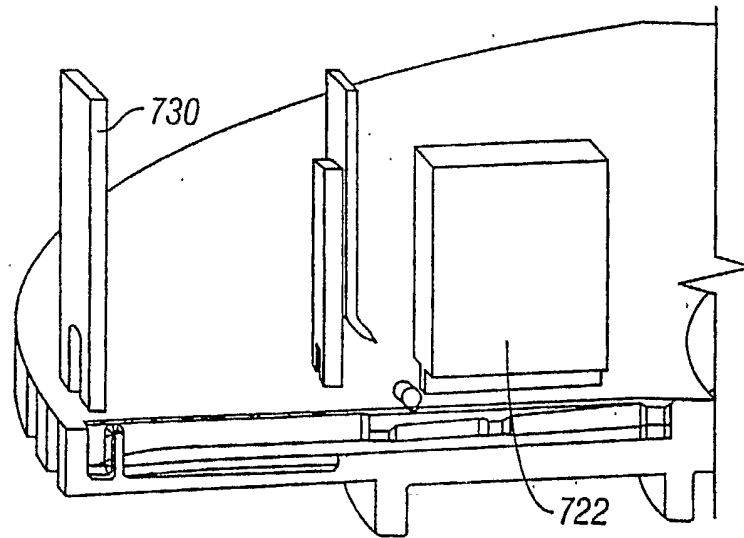

FIG. 69L

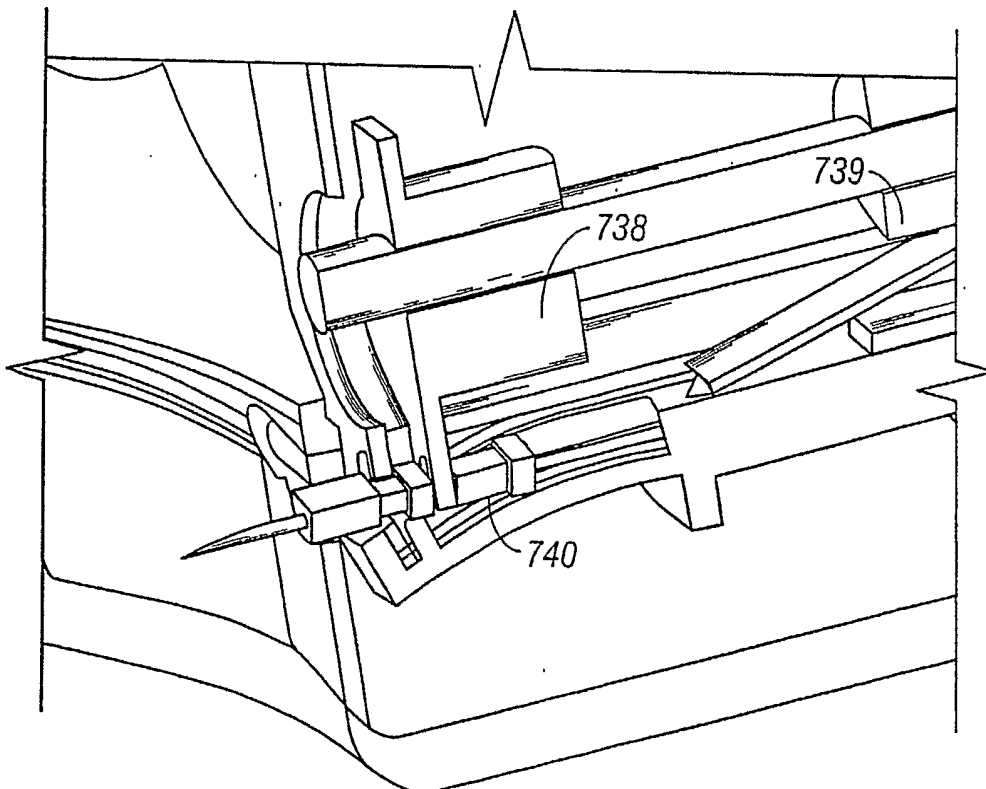

FIG. 70

41/51

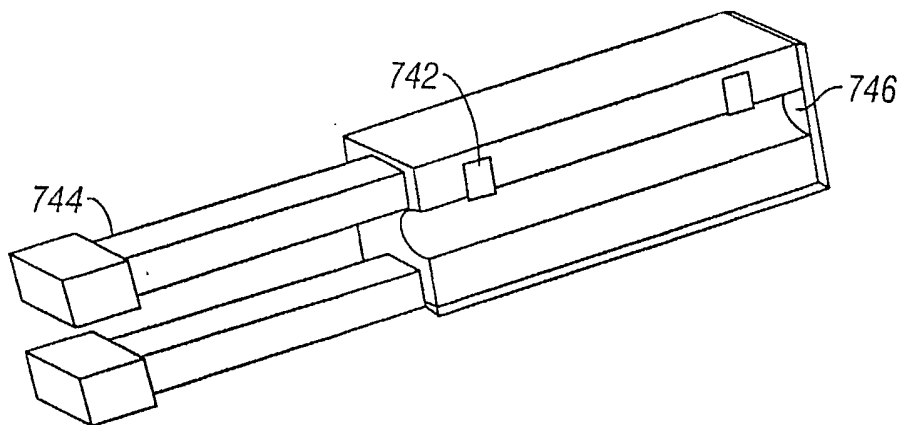

FIG. 71

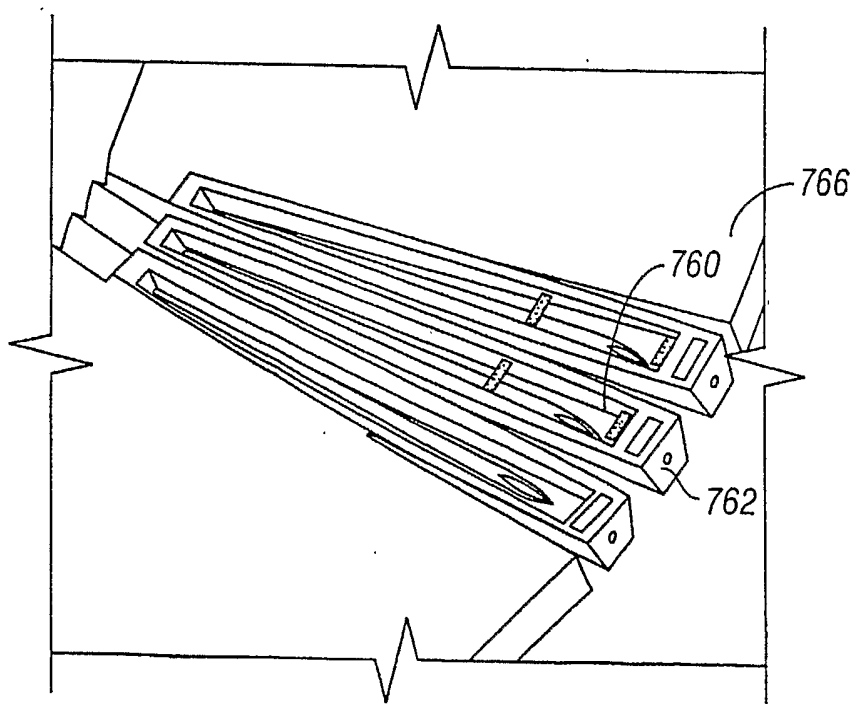

FIG. 72

42/51

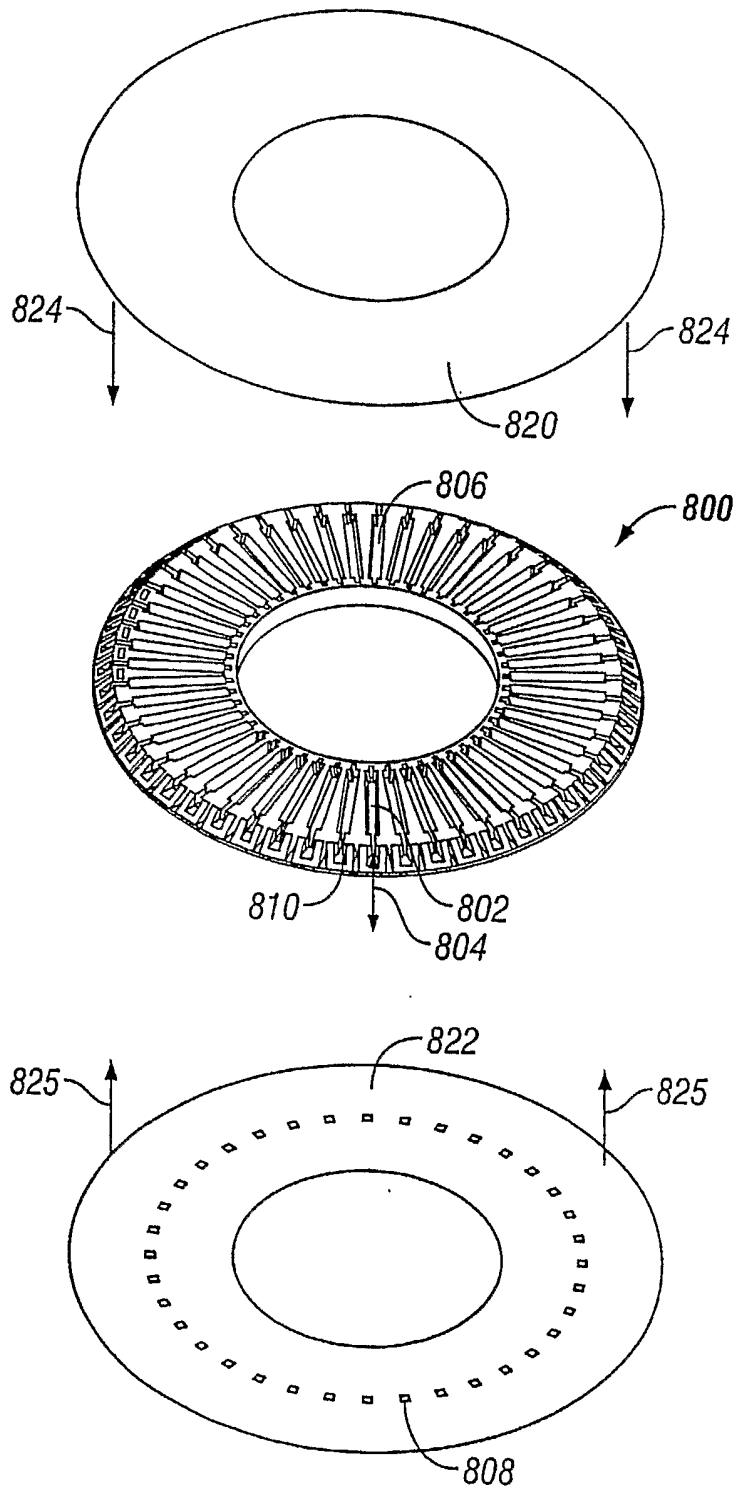

FIG. 73

43/51

800

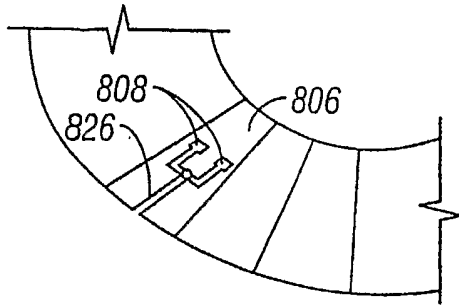

FIG. 74

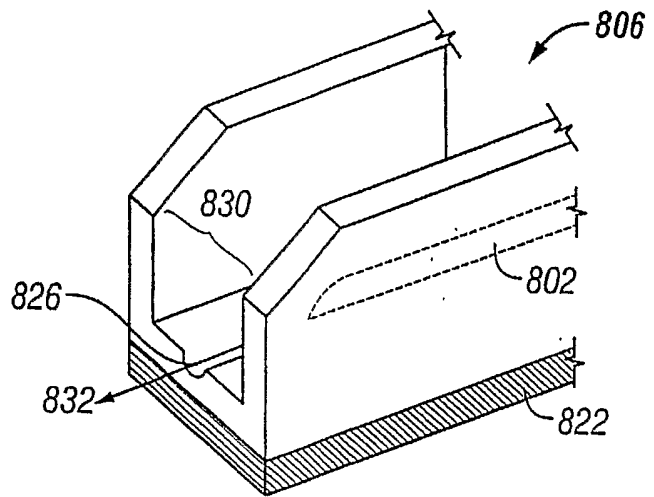

FIG. 75

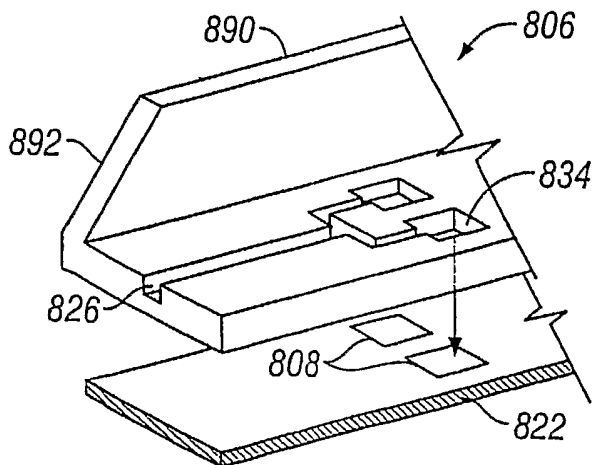

FIG. 76

44/51

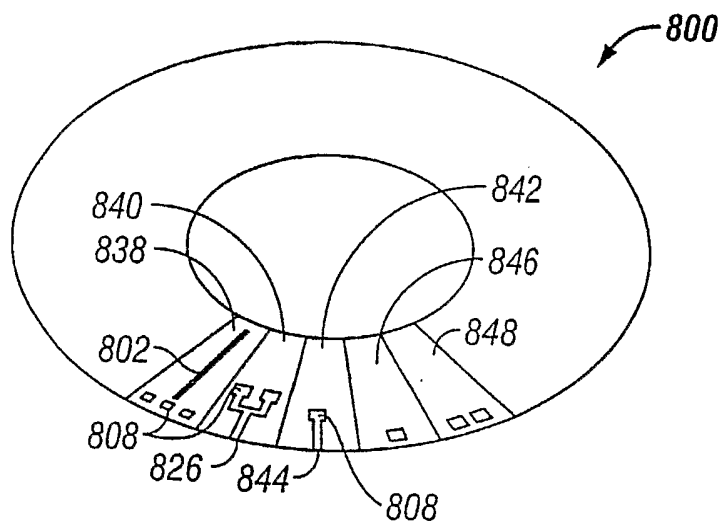

FIG. 77

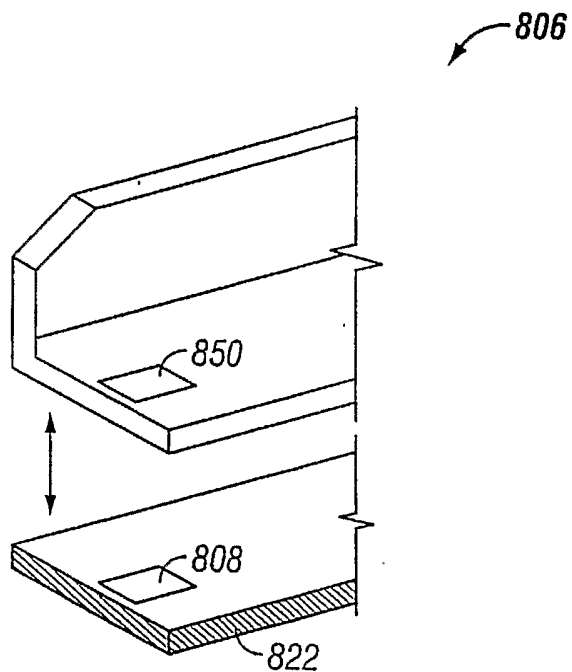

FIG. 78

45/51

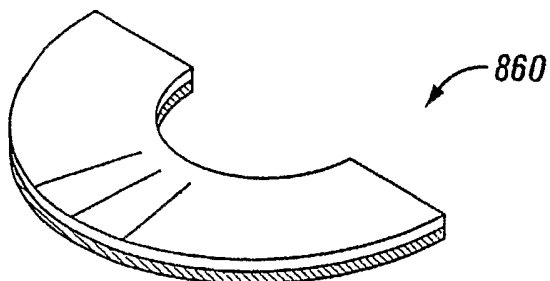

FIG. 79

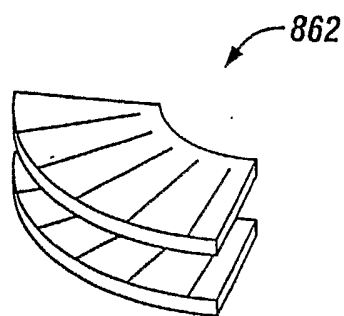

FIG. 80

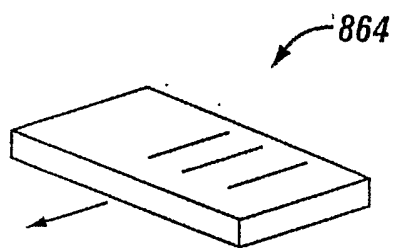

FIG. 81

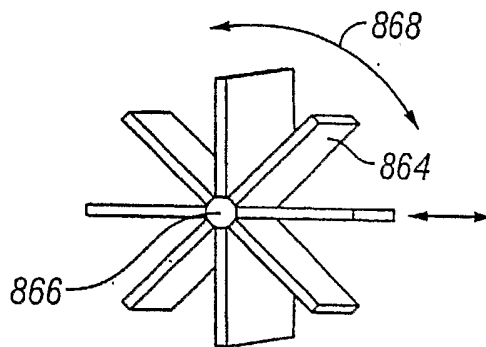

FIG. 82

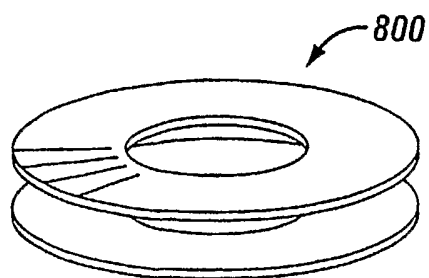

FIG. 83

46/51

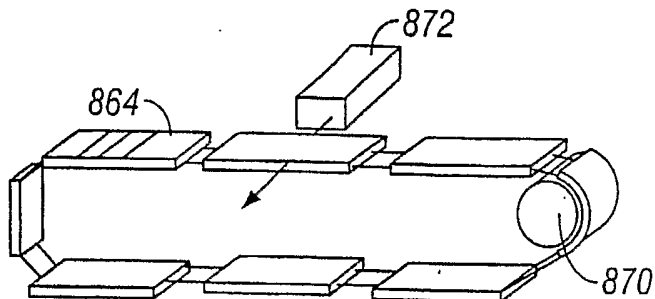

FIG. 84

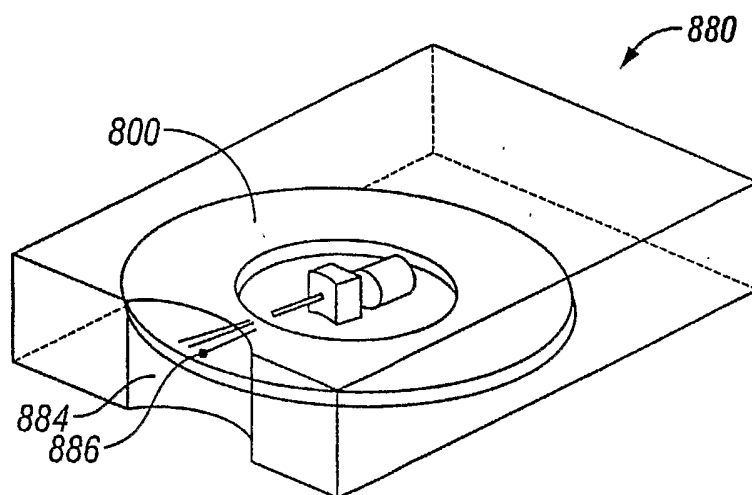

FIG. 85

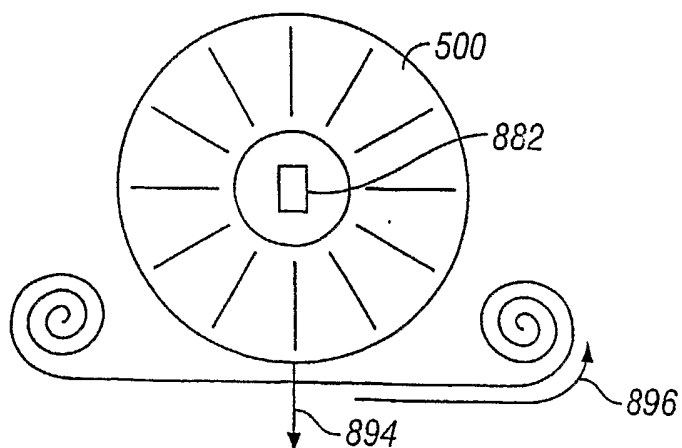

FIG. 86

47/51

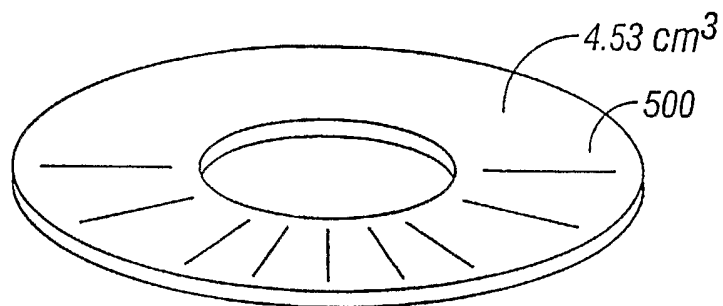

FIG. 87A

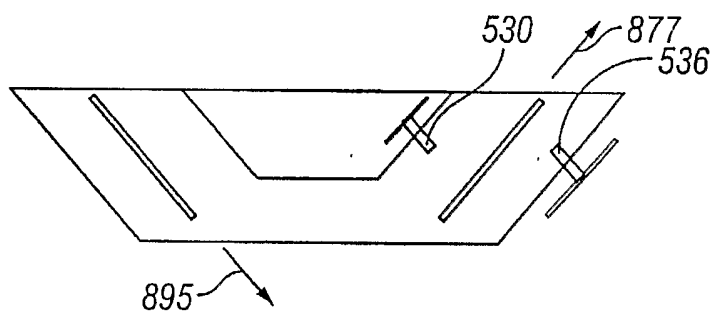

FIG. 87B

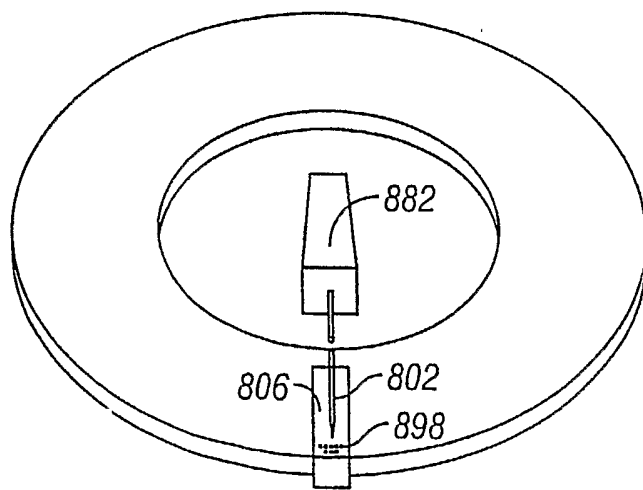

FIG. 88

48/51

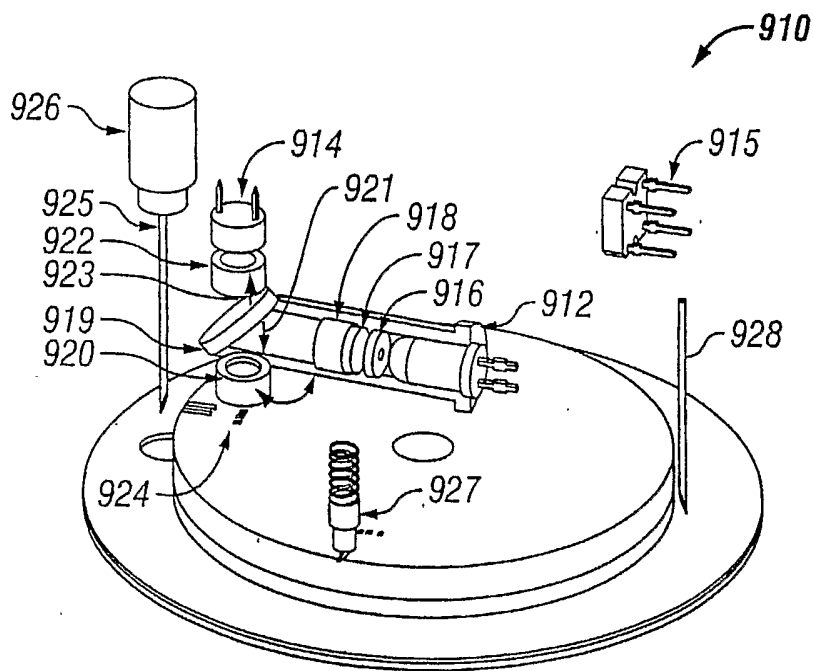

FIG. 89

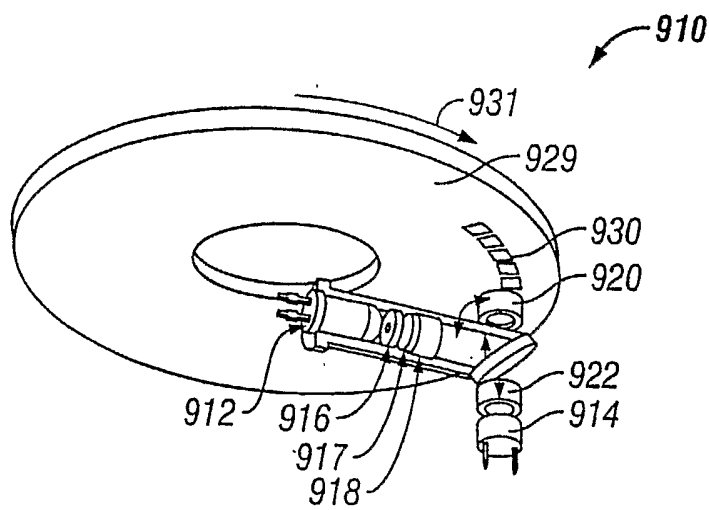

FIG. 90

49/51

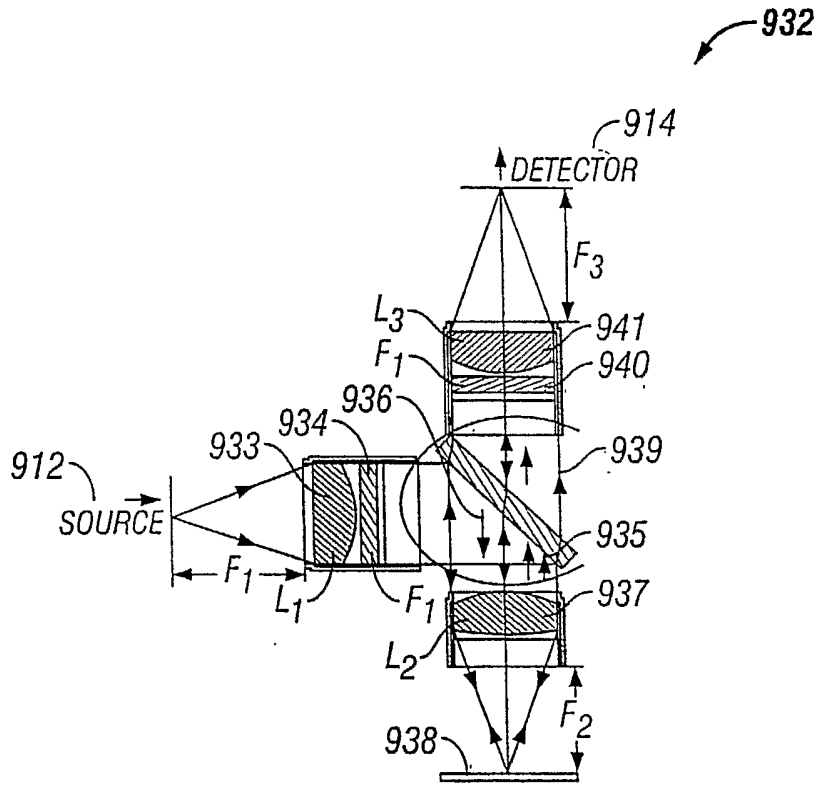

FIG. 91

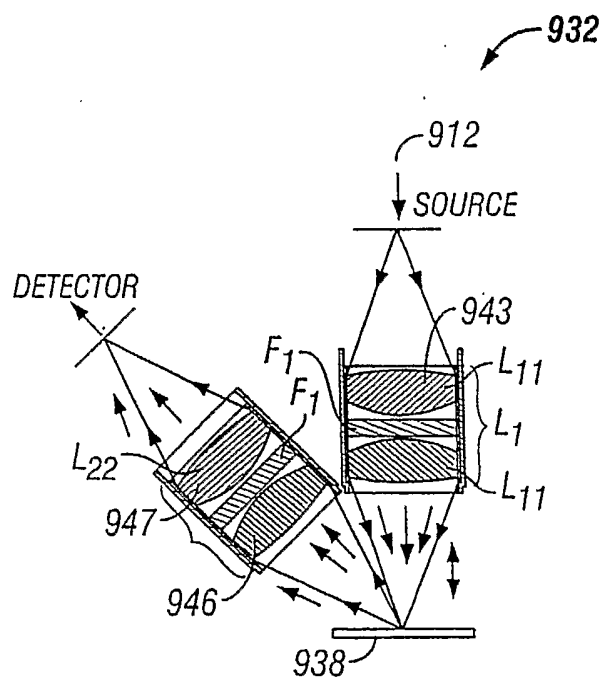

FIG. 92

50/51

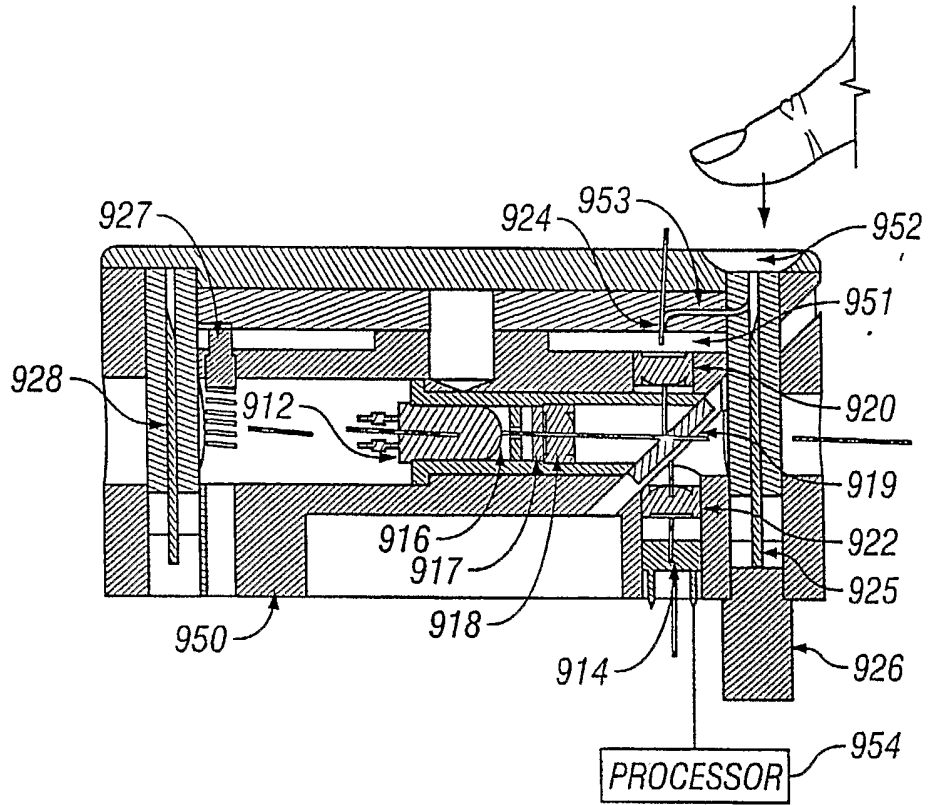

FIG. 93

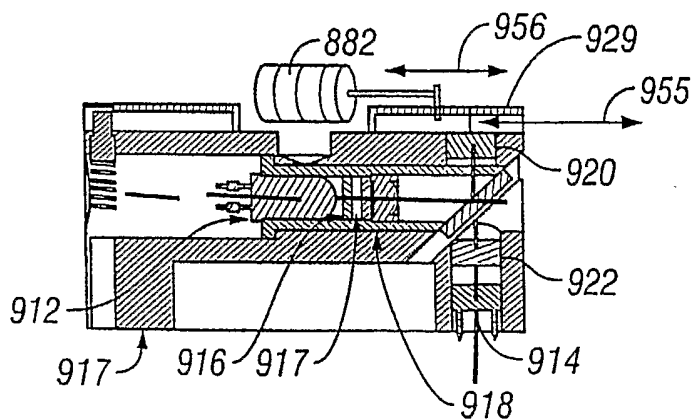

FIG. 94

51/51

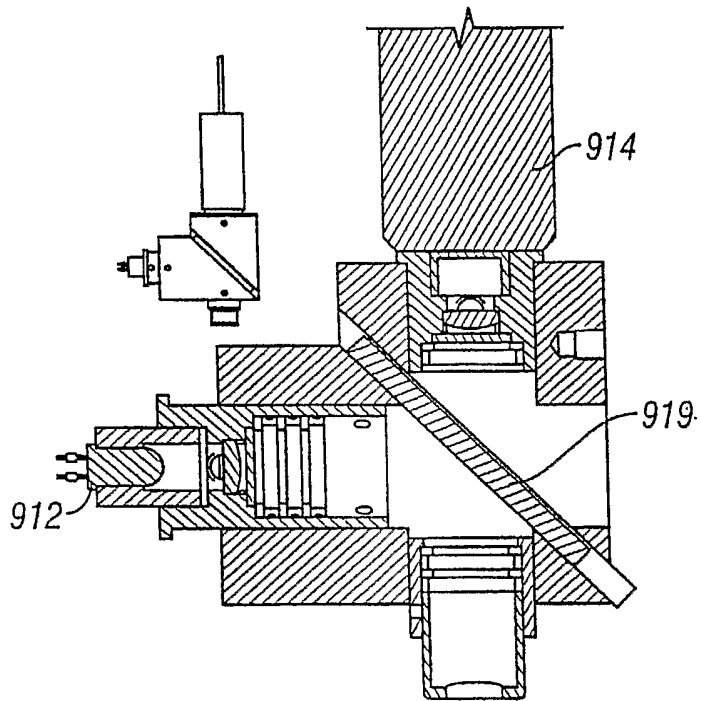

FIG. 95

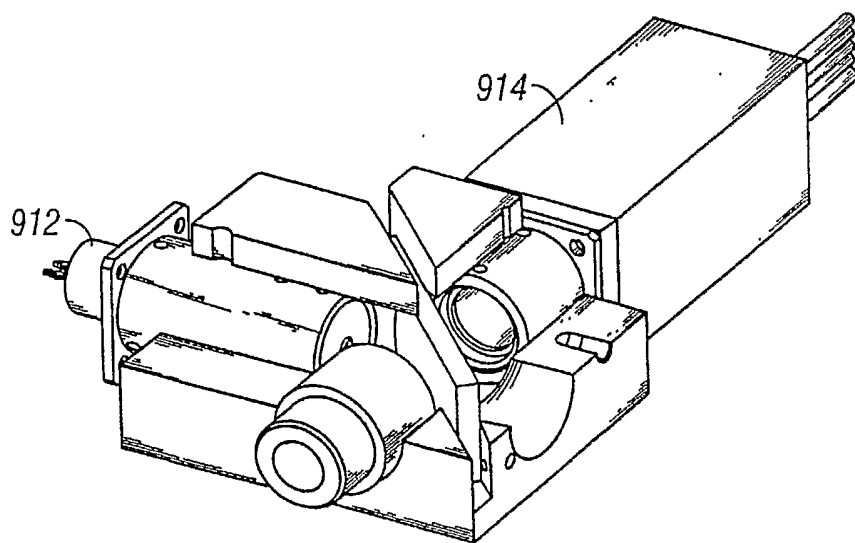

FIG. 96

INTERNATIONAL SEARCH REPORT

International application No.

PCT/US03/12381

A. CLASSIFICATION OF SUBJECT MATTER		
IPC(7) : A61B 5/00 US CL : 606/181		
According to International Patent Classification (IPC) or to both national classification and IPC		
B. FIELDS SEARCHED		
Minimum documentation searched (classification system followed by classification symbols) U.S. : 606/181,182,167; 600/564,565,583,584		
Documentation searched other than minimum documentation to the extent that such documents are included in the fields searched		
Electronic data base consulted during the international search (name of data base and, where practicable, search terms used)		
C. DOCUMENTS CONSIDERED TO BE RELEVANT		
Category *	Citation of document, with indication, where appropriate, of the relevant passages	Relevant to claim No.
X ---	US 6,071,294 A (Simons et al.) 06 June 2000, see entire document.	1-53 and 55-61
Y		----- 62-119
X	US 6,132,449 A (Lum et al.) 17 October 2000, see entire document.	54, 128-145, 167-174, 188-195, 203, 208-213
X	US 4,983,178 A (Schnell) 08 January 1991, see entire document.	120-157
X ---	US 6,315,738 B1 (Nishikawa et al.) 13 November 2001, see entire document.	158-187
Y		----- 196-202, 204-207 and 214-215
<input type="checkbox"/> Further documents are listed in the continuation of Box C. <input type="checkbox"/> See patent family annex.		
* Special categories of cited documents:		
"A" document defining the general state of the art which is not considered to be of particular relevance	"T" later document published after the international filing date or priority date and not in conflict with the application but cited to understand the principle or theory underlying the invention	
"E" earlier application or patent published on or after the international filing date	"X" document of particular relevance; the claimed invention cannot be considered novel or cannot be considered to involve an inventive step when the document is taken alone	
"L" document which may throw doubts on priority claim(s) or which is cited to establish the publication date of another citation or other special reason (as specified)	"Y" document of particular relevance; the claimed invention cannot be considered to involve an inventive step when the document is combined with one or more other such documents, such combination being obvious to a person skilled in the art	
"O" document referring to an oral disclosure, use, exhibition or other means	"&" document member of the same patent family	
"P" document published prior to the international filing date but later than the priority date claimed		
Date of the actual completion of the international search	Date of mailing of the international search report	
20 August 2003 (20.08.2003)	12 SEP 2003	
Name and mailing address of the ISA/US Mail Stop PCT, Attn: ISA/US Commissioner for Patents P.O. Box 1450 Alexandria, Virginia 22313-1450 Facsimile No. (703)305-3230	Authorized officer Victor Nguyen Telephone No. (703) 305-4898	