



(19) **United States**

(12) **Patent Application Publication**

**Rossetto et al.**

(10) **Pub. No.: US 2019/0021793 A1**

(43) **Pub. Date: Jan. 24, 2019**

(54) **LEAKY-WAVE ANTENNAS FOR MEDICAL APPLICATIONS**

(71) Applicant: **Covidien LP**, Mansfield, MA (US)

(72) Inventors: **Francesca Rossetto**, Longmont, CO (US); **Joseph D. Brannan**, Erie, CO (US); **Joseph A. Paulus**, Louisville, CO (US); **Christopher A. Deborski**, Denver, CO (US)

(21) Appl. No.: **16/139,501**

(22) Filed: **Sep. 24, 2018**

**Related U.S. Application Data**

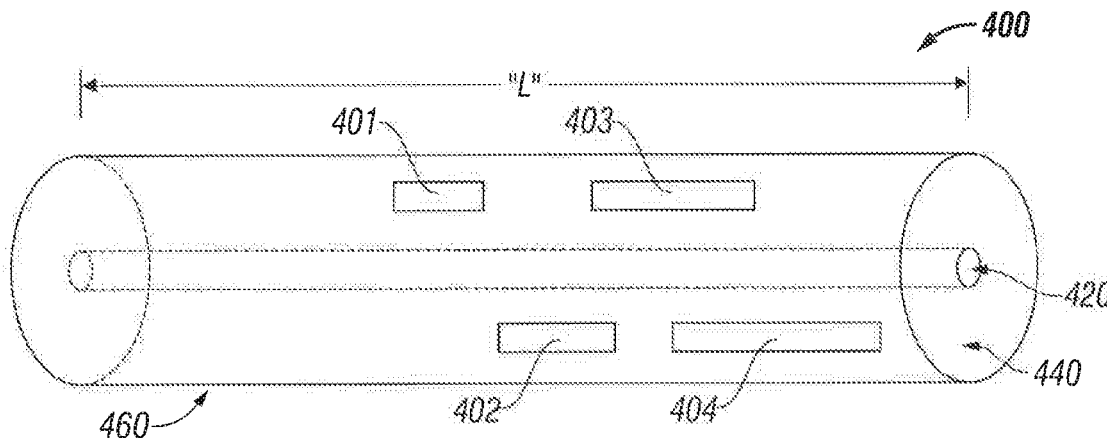
(63) Continuation of application No. 14/636,307, filed on Mar. 3, 2015, now Pat. No. 10,080,610, which is a continuation of application No. 14/192,142, filed on Feb. 27, 2014, now Pat. No. 8,968,292, which is a continuation of application No. 13/483,858, filed on May 30, 2012, now Pat. No. 8,679,108, which is a continuation of application No. 12/389,906, filed on Feb. 20, 2009, now Pat. No. 8,197,473.

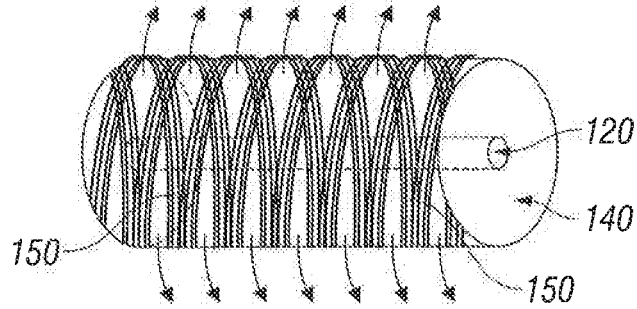
**Publication Classification**

(51) **Int. Cl.**  
*A61B 18/18* (2006.01)  
*H04B 5/00* (2006.01)  
*H01Q 13/20* (2006.01)  
*H01Q 1/27* (2006.01)  
(52) **U.S. Cl.**  
CPC ..... *A61B 18/1815* (2013.01); *H04B 5/0018* (2013.01); *H01Q 13/203* (2013.01); *A61B 2018/1838* (2013.01); *H01Q 1/273* (2013.01); *A61B 2018/1823* (2013.01); *A61B 18/18* (2013.01)

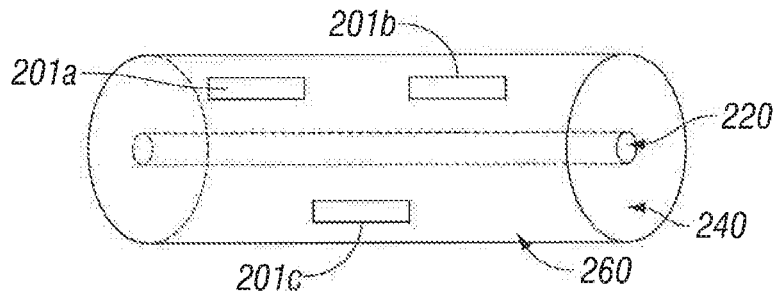
(57) **ABSTRACT**

A device for directing energy to a target volume of tissue includes an inner conductor having a length and an outer conductor coaxially surrounding the inner conductor along the length. The outer conductor has a proximal portion and a distal portion. The distal portion of the outer conductor is provided with a number of apertures *N* defined therein for radiating energy, where *N* is an integer greater than 1, each aperture having a size and angle extending at an angle relative to a longitudinal axis of the outer conductor. At least one of the size and the angle of each aperture is varied in relation to the other apertures *N*-1 such that the energy radiated along the distal portion is substantially uniform.

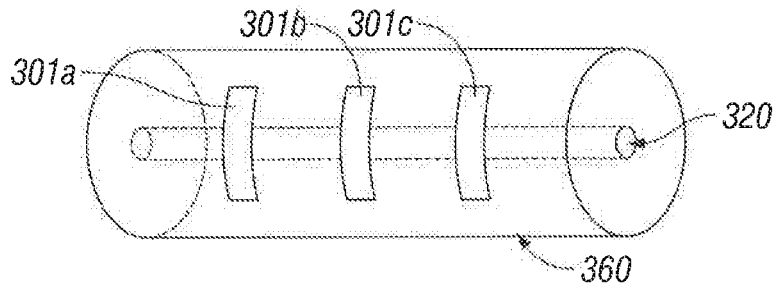




**FIG. 1**  
**(Prior Art)**



**FIG. 2**  
**(Prior Art)**



**FIG. 3**  
**(Prior Art)**

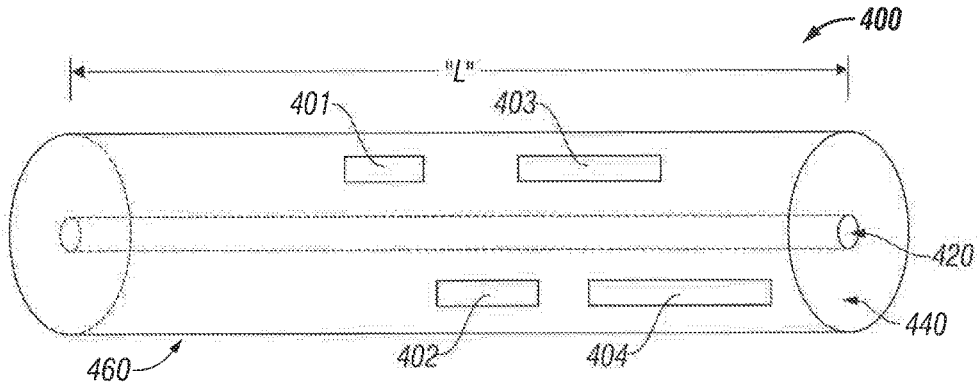


FIG. 4

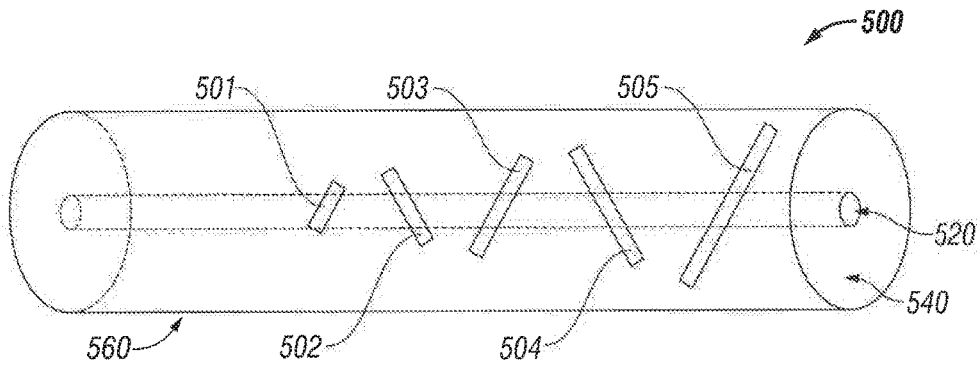


FIG. 5

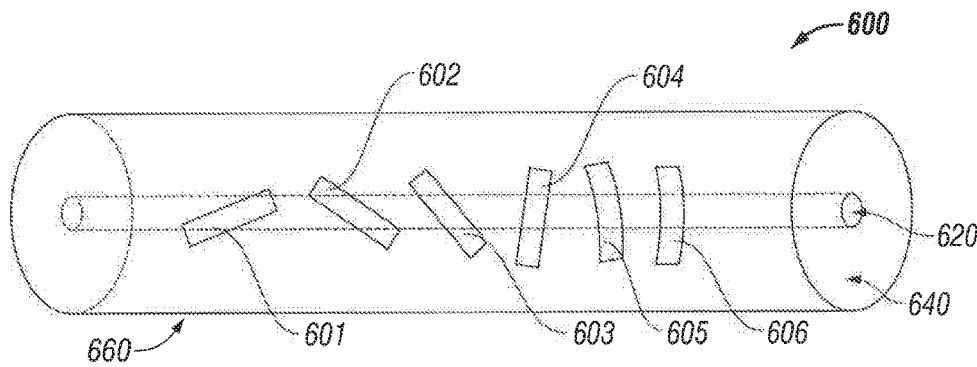


FIG. 6

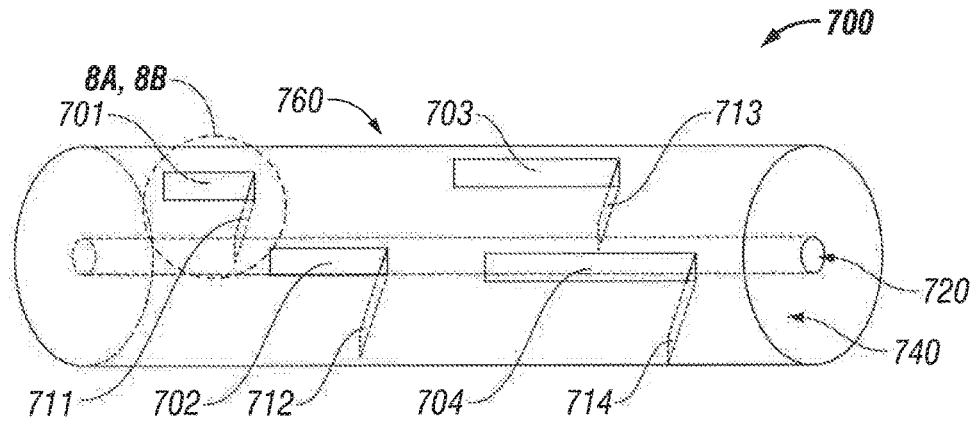


FIG. 7

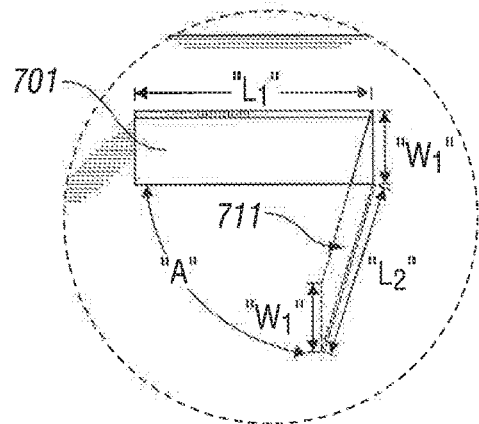


FIG. 8A

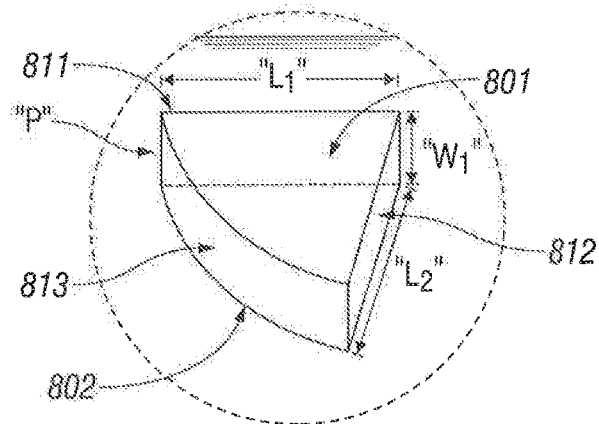


FIG. 8B

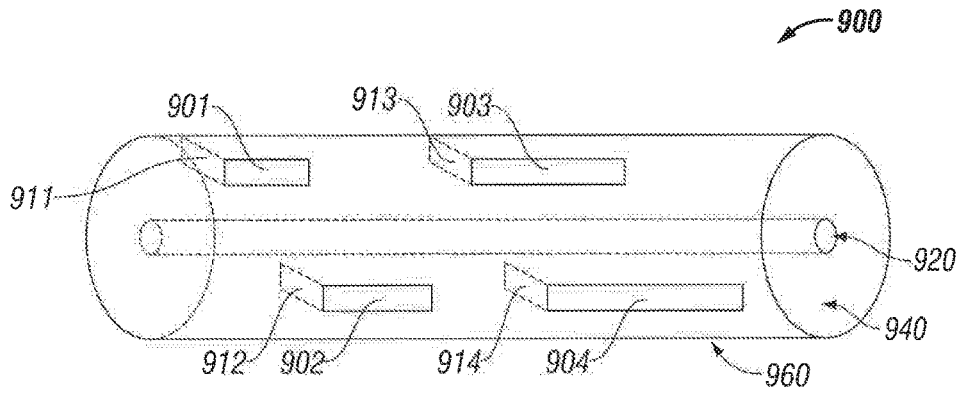


FIG. 9

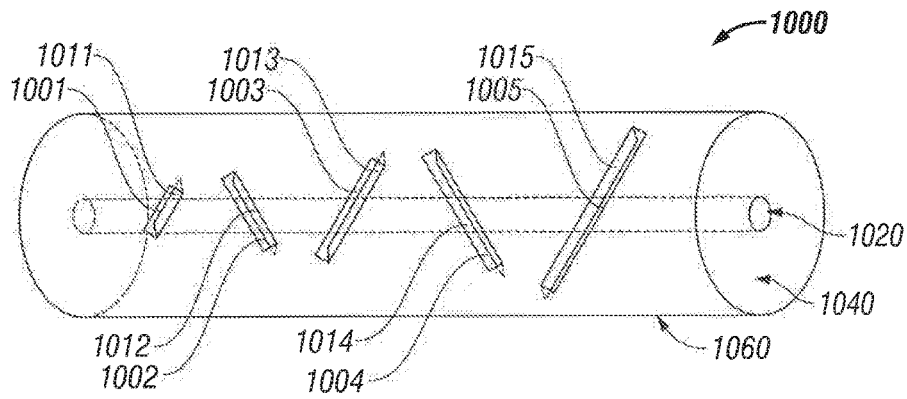


FIG. 10

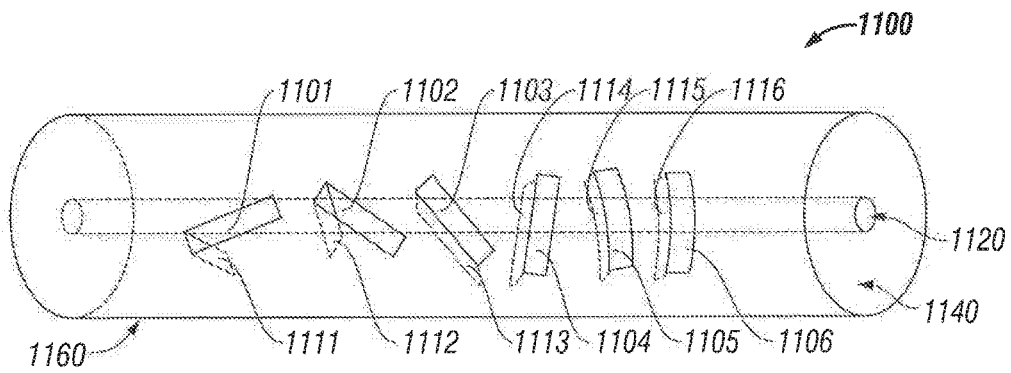


FIG. 11

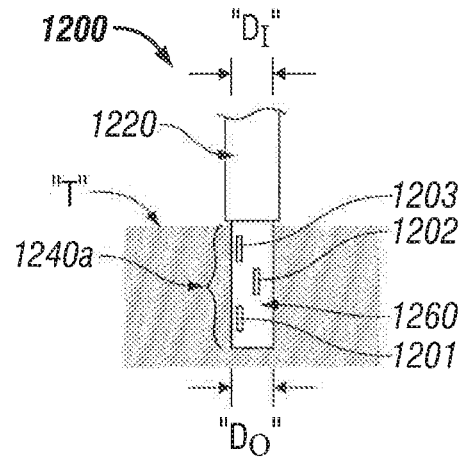


FIG. 12A

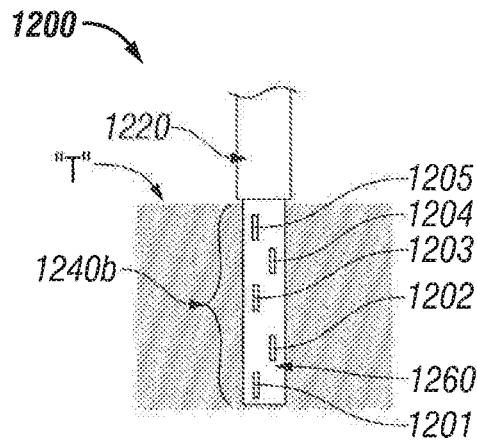


FIG. 12B

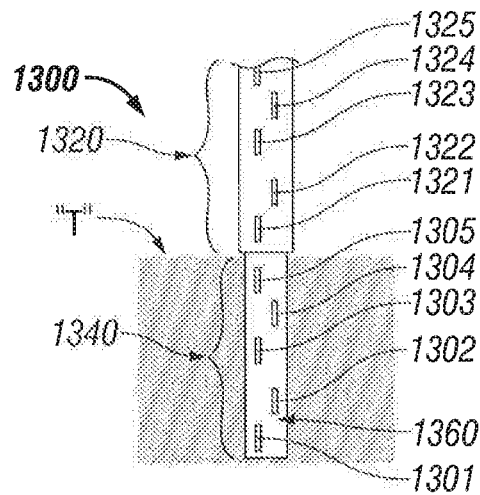


FIG. 13

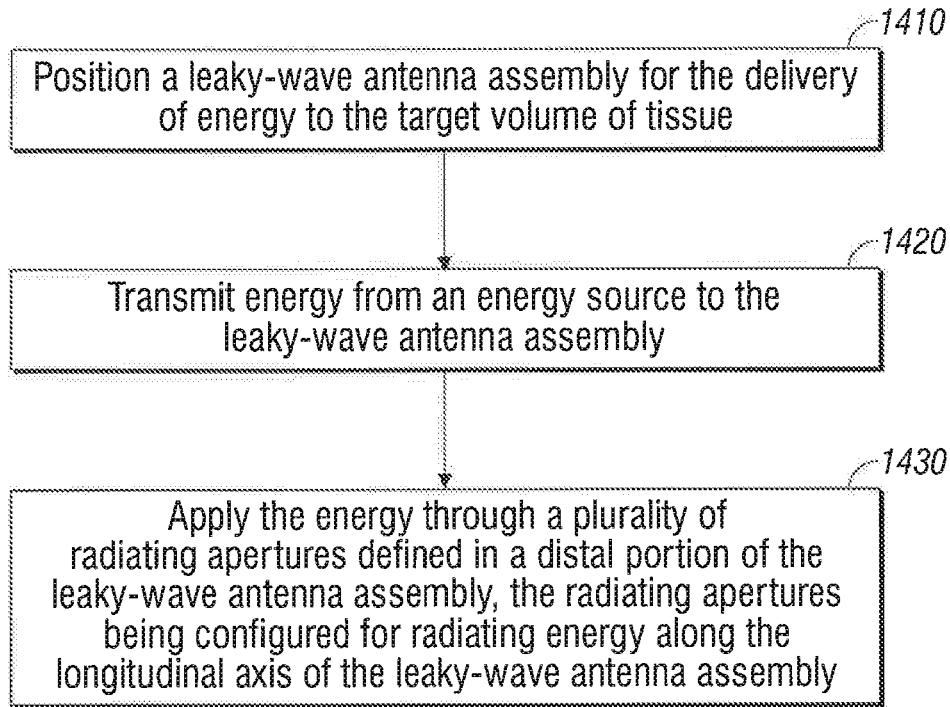


FIG. 14

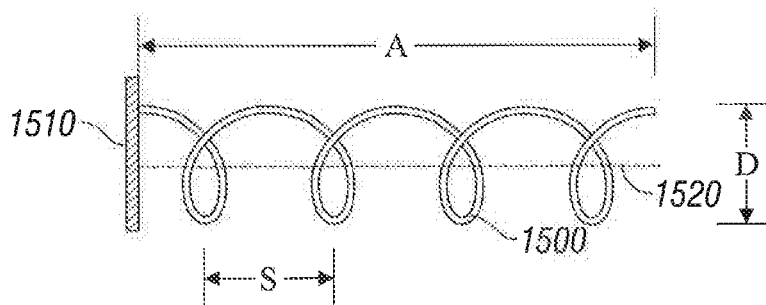


FIG. 15

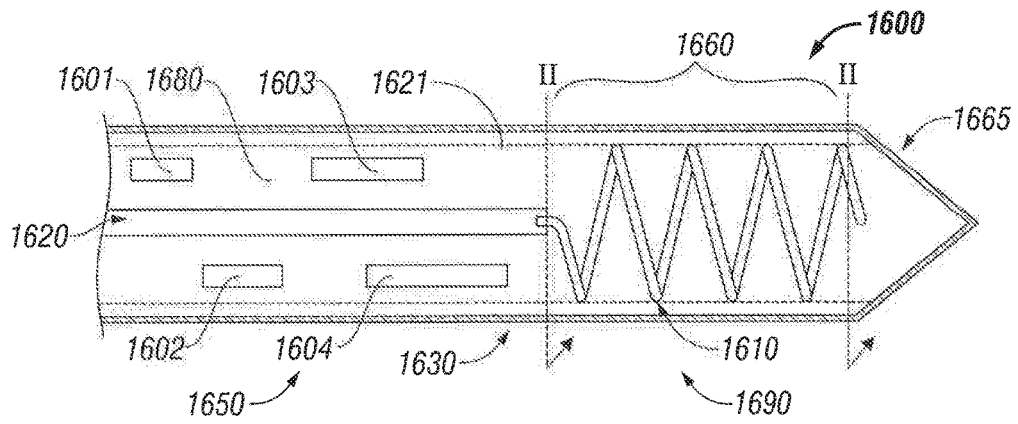


FIG. 16

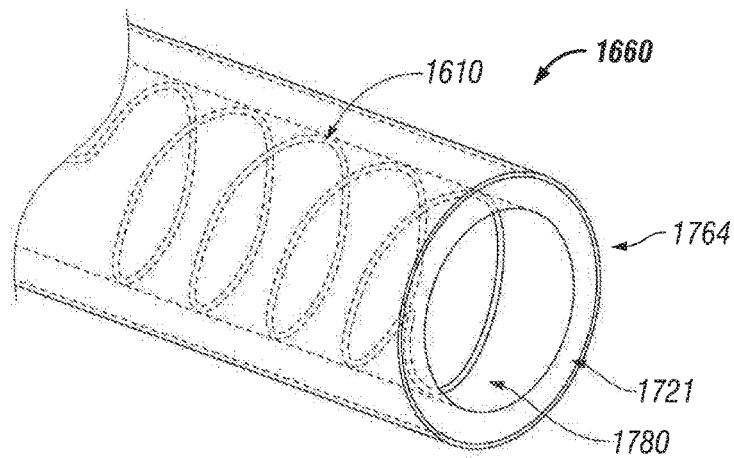


FIG. 17

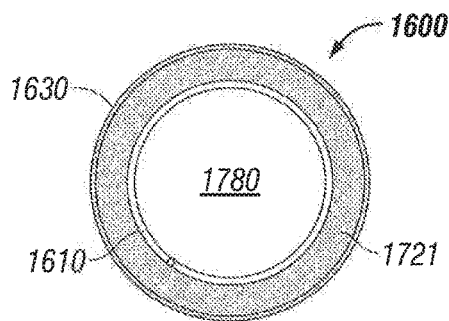


FIG. 18

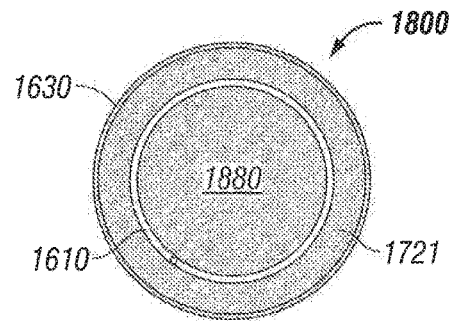


FIG. 19



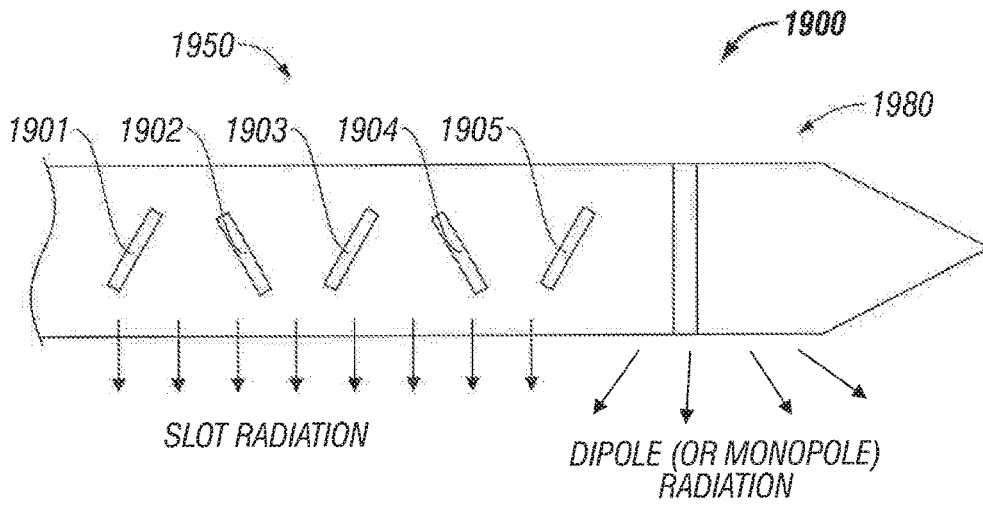


FIG. 20

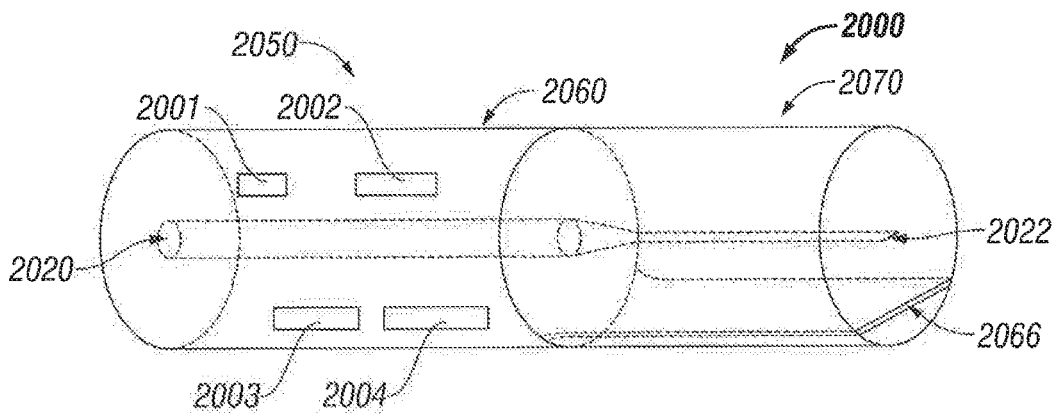


FIG. 21

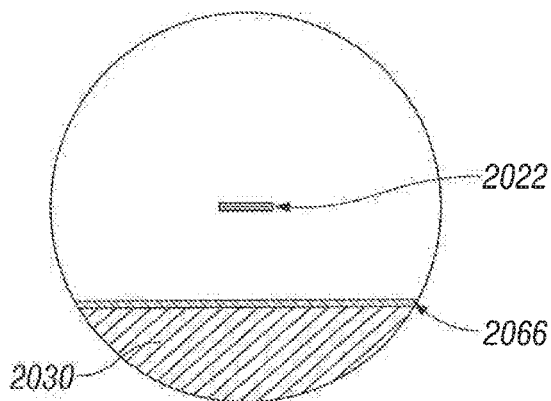


FIG. 22

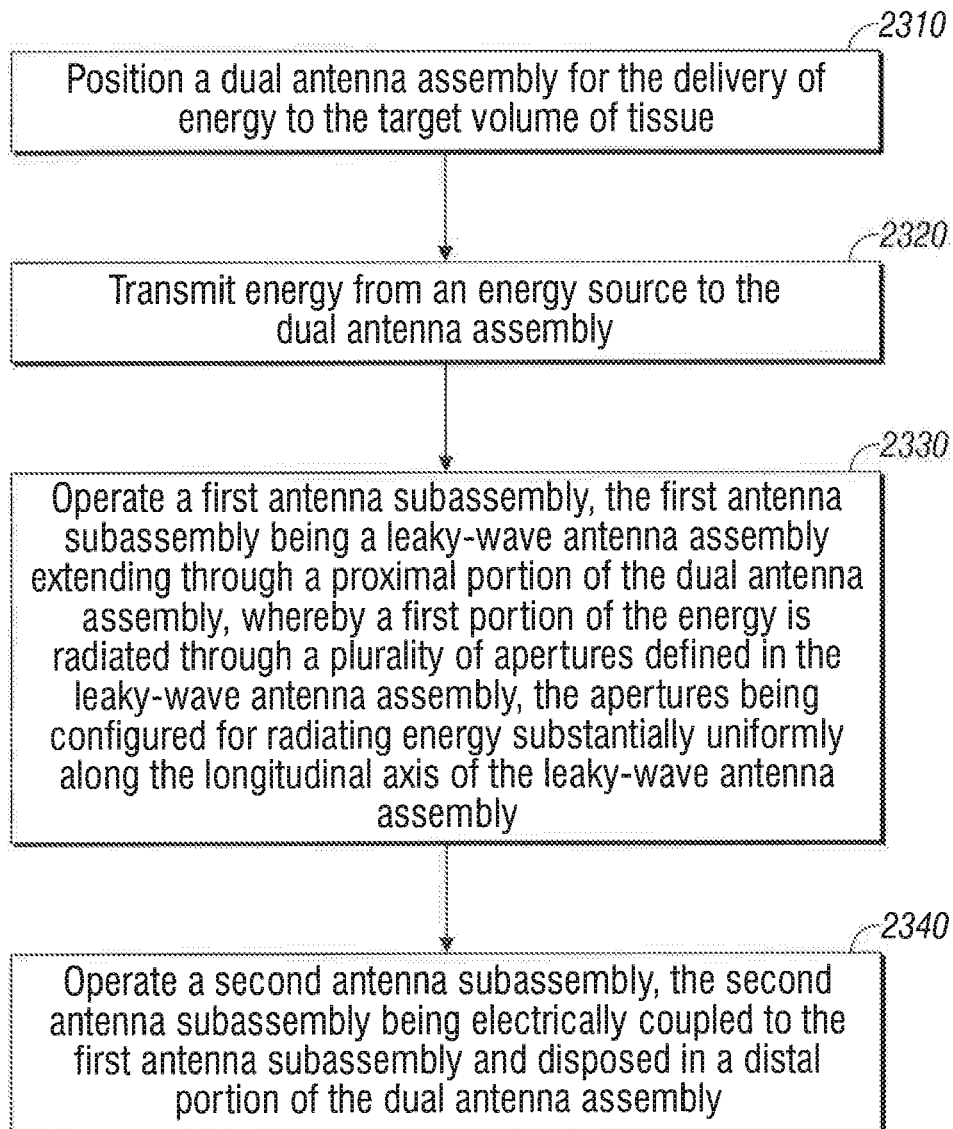


FIG. 23

## LEAKY-WAVE ANTENNAS FOR MEDICAL APPLICATIONS

### CROSS-REFERENCE TO RELATED APPLICATIONS

[0001] The present application is a continuation of U.S. patent application Ser. No. 14/636,307, filed Mar. 3, 2015, which is a continuation application of U.S. patent application Ser. No. 14/192,142, filed Feb. 27, 2014, now U.S. Pat. No. 8,968,292, which is a continuation application of U.S. patent application Ser. No. 13/483,858, filed May 30, 2012, now U.S. Pat. No. 8,679,108, which is a continuation application of U.S. patent application Ser. No. 12/389,906, filed Feb. 20, 2009, now U.S. Pat. No. 8,197,473. The entire disclosures of all of the foregoing applications are incorporated by reference herein.

### BACKGROUND

#### 1. Technical Field

[0002] The present disclosure relates to antennas and, more particularly, to electrosurgical devices with leaky-wave antenna assemblies suitable for use in tissue ablation applications.

#### 2. Discussion of Related Art

[0003] Treatment of certain diseases requires the destruction of malignant tumors. Electromagnetic radiation can be used to heat and destroy tumor cells. Treatment may involve inserting ablation probes into tissues where cancerous tumors have been identified. Once the probes are positioned, electromagnetic energy is passed through the probes into surrounding tissue.

[0004] In the treatment of diseases such as cancer, certain types of cancer cells have been found to denature at elevated temperatures that are slightly lower than temperatures normally injurious to healthy cells. Known treatment methods, such as hyperthermia therapy, use electromagnetic radiation to heat diseased cells to temperatures above 41° C. while maintaining adjacent healthy cells below the temperature at which irreversible cell destruction occurs. These methods involve applying electromagnetic radiation to heat, ablate and/or coagulate tissue. Microwave energy is sometimes utilized to perform these methods. Other procedures utilizing electromagnetic radiation to heat tissue also include coagulation, cutting and/or ablation of tissue.

[0005] Electrosurgical devices utilizing electromagnetic radiation have been developed for a variety of uses and applications. A number of devices are available that can be used to provide high bursts of energy for short periods of time to achieve cutting and coagulative effects on various tissues. There are a number of different types of apparatus that can be used to perform ablation procedures. Typically, microwave apparatus for use in ablation procedures include a microwave generator, which functions as an energy source, and a microwave surgical instrument having an antenna assembly for directing the energy to the target tissue. The microwave generator and surgical instrument are typically operatively coupled by a cable assembly having a plurality of conductors for transmitting microwave energy from the generator to the instrument, and for communicating control, feedback and identification signals between the instrument and the generator.

[0006] Microwave energy is typically applied via antenna assemblies that can penetrate tissue. Several types of microwave antenna assemblies are known, such as monopole, dipole and helical. In monopole and dipole antenna assemblies, microwave energy generally radiates perpendicularly away from the axis of the conductor. A monopole antenna assembly includes a single, elongated conductor that transmits microwave energy. A typical dipole antenna assembly has two elongated conductors, which are linearly aligned and positioned end-to-end relative to one another with an electrical insulator placed therebetween. Helical antenna assemblies have two main modes of operation: normal mode (broadside) and axial mode (endfire). In the normal mode of operation, the field radiated by the helix is maximum in a perpendicular plane to the helix axis. In the axial mode, maximum radiation is along the helix axis.

[0007] A typical microwave transmission line assembly has a long, thin inner conductor that extends along a longitudinal transmission line axis and is surrounded by a dielectric material and is further surrounded by an outer conductor around the dielectric material such that the outer conductor also extends along the transmission line axis. In one variation of an antenna, the outer conductor is provided with a plurality of slots along a length of transmission line. This type of construction is typically referred to as a “leaky coaxial” or “leaky wave” antenna. A leaky wave antenna is basically a waveguiding structure constructed so as to “leak” power along the length of the guiding structure. In a leaky-wave antenna, as the microwave signal propagates inside the guiding structure (i.e., transmission line or coaxial cable), it “leaks” out through openings in the outer conductor, causing radiation.

[0008] Examples of leaky coaxial antennas include loose braid coaxial cables and slotted coaxial cables, which are sometimes used for communications applications such as, for example, transmitting and receiving signals within tunnels or buildings. A typical loose braid coaxial cable is shown in FIG. 1 and includes an inner conductor 120, an outer conductor 150 coaxially surrounding the inner conductor 120, and a dielectric material 140 separating the inner and outer conductors. The direction of the radiation pattern of the loose braid coaxial cable is indicated by the curved arrows in FIG. 1. An example of a slotted coaxial cable is illustrated in FIG. 2 and includes a central conductor 220, a cylindrical outer conductor 260, which is provided with a plurality of elongated slots 201A, 201B and 201C, and a dielectric material 240 separating the inner and outer conductors. In the slotted coaxial cable illustrated in FIG. 2, the slots 201A, 201B and 201C longitudinally extend along the longitudinal axis of the inner conductor 220. In the slotted coaxial cable shown in FIG. 3, a plurality of slots 301A, 301B and 301C are formed in the outer conductor 360 such that the longitudinal axis of each slot extends perpendicular to the longitudinal axis of the central conductor 320.

[0009] During certain procedures, it can be difficult to assess the extent to which the microwave energy will radiate into the surrounding tissue, making it difficult to determine the area or volume of surrounding tissue that will be ablated.

### SUMMARY

[0010] The present disclosure relates to a device for directing energy to a target volume of tissue including an inner conductor having a length and an outer conductor coaxially surrounding the inner conductor along the length. The outer

conductor has a proximal portion and a distal portion. The distal portion of the outer conductor is provided with a number of apertures  $N$  defined therein for radiating energy, where  $N$  is an integer greater than 1, each aperture having a size and extending at an angle relative to a longitudinal axis of the outer conductor. At least one of the size and the angle of each aperture is varied in relation to the other apertures  $N-1$  such that the energy radiated along the distal portion is substantially uniform.

**[0011]** The present disclosure also relates to a system for directing energy to a target volume of tissue including a leaky-wave antenna assembly that includes an inner conductor and an outer conductor, each extending therethrough, wherein the inner conductor is disposed within the outer conductor. A distal portion of the outer conductor is provided with a number of apertures  $N$  defined therein for radiating energy, where  $N$  is an integer greater than 1, each aperture having a size and extending at an angle relative to a longitudinal axis of the outer conductor, wherein at least one of the size and the angle of each aperture is varied in relation to the other apertures  $N-1$  such that the energy radiated along the distal portion is substantially the same.

**[0012]** The present disclosure also relates to a method for directing energy to a target volume of tissue including the step of positioning a leaky-wave antenna assembly for delivery of energy to the target volume of tissue. The method also includes the steps of: transmitting energy from an energy source to the leaky-wave antenna assembly; and applying the energy through a plurality of radiating apertures defined in a distal portion of the leaky-wave antenna assembly, the radiating apertures configured for radiating energy substantially uniformly along the longitudinal axis of the leaky-wave antenna assembly.

#### BRIEF DESCRIPTION OF THE DRAWINGS

**[0013]** Objects and features of the presently disclosed leaky-wave antenna assemblies will become apparent to those of ordinary skill in the art when descriptions of various embodiments thereof are read with reference to the accompanying drawings, of which:

**[0014]** FIG. 1 is a perspective view of a prior art loose braid coaxial cable;

**[0015]** FIG. 2 is a perspective view of a prior art slotted coaxial cable;

**[0016]** FIG. 3 is a perspective view of another prior art slotted coaxial cable;

**[0017]** FIG. 4 is a perspective view of a leaky-wave antenna assembly according to an embodiment of the present disclosure;

**[0018]** FIG. 5 is a perspective view of another embodiment of a leaky-wave antenna assembly according to the present disclosure;

**[0019]** FIG. 6 is a perspective view of yet another embodiment of a leaky-wave antenna assembly according to the present disclosure;

**[0020]** FIG. 7 is a perspective view of a leaky-wave antenna assembly configured with inclusion elements extending inwardly from the outer conductor according to an embodiment of the present disclosure;

**[0021]** FIG. 8A is an enlarged view of the indicated area of detail of FIG. 7 according to an embodiment of the present disclosure;

**[0022]** FIG. 8B is an enlarged view of the indicated area of detail of FIG. 7 according to another embodiment of the present disclosure;

**[0023]** FIG. 9 is a perspective view of another embodiment of a leaky-wave antenna assembly configured with inclusion elements extending inwardly from the outer conductor according to the present disclosure;

**[0024]** FIG. 10 is a perspective view of the leaky-wave antenna assembly illustrated in FIG. 5 shown with inclusion elements extending inwardly from the outer conductor according to an embodiment of the present disclosure;

**[0025]** FIG. 11 is a perspective view of the leaky-wave antenna assembly illustrated in FIG. 6 shown with inclusion elements extending inwardly from the outer conductor according to an embodiment of the present disclosure;

**[0026]** FIGS. 12A and 12B are schematic diagrams of a leaky-wave antenna assembly including a sleeve member according to an embodiment of the present disclosure;

**[0027]** FIG. 13 is a schematic diagram of a leaky-wave antenna assembly including a sleeve member according to another embodiment of the present disclosure;

**[0028]** FIG. 14 is a flowchart illustrating a method of directing energy to a target volume of tissue according to an embodiment of the present disclosure;

**[0029]** FIG. 15 is a schematic diagram showing the basic geometry of a helical antenna;

**[0030]** FIG. 16 is a schematic diagram showing a dual antenna assembly including a leaky-wave antenna assembly and a helical antenna assembly according to an embodiment of the present disclosure;

**[0031]** FIG. 17 is a perspective view of a portion of the helical antenna assembly shown in FIG. 16 taken along the lines II-II;

**[0032]** FIG. 18 is a cross-sectional view of the helical antenna radiating section shown in FIG. 17;

**[0033]** FIG. 19 is a cross-sectional view of the helical antenna radiating section of FIG. 17 shown with a dielectric material located in an interior of the helical antenna element according to an embodiment of the present disclosure;

**[0034]** FIG. 20 is a schematic diagram showing a dual antenna assembly according to an embodiment of the present disclosure;

**[0035]** FIG. 21 is a perspective view of a dual antenna assembly including a leaky-wave antenna assembly and a microstrip antenna assembly according to an embodiment of the present disclosure;

**[0036]** FIG. 22 is a cross-sectional view of the distal portion of the dual antenna assembly of FIG. 21; and

**[0037]** FIG. 23 is a flowchart illustrating a method of directing energy to a target volume of tissue according to an embodiment of the present disclosure.

#### DETAILED DESCRIPTION

**[0038]** Hereinafter, embodiments of the presently disclosed leaky-wave antenna assemblies will be described with reference to the accompanying drawings. Like reference numerals may refer to similar or identical elements throughout the description of the figures.

**[0039]** Electromagnetic energy is generally classified by increasing energy or decreasing wavelength into radio waves, microwaves, infrared, visible light, ultraviolet, X-rays and gamma-rays. As used herein, the term "microwave" generally refers to electromagnetic waves in the frequency range of 300 megahertz (MHz) ( $3 \times 10^8$  cycles/

second) to 300 gigahertz (GHz) ( $3 \times 10^{11}$  cycles/second). As used herein, the phrase “ablation procedure” generally refers to any ablation procedure, such as microwave ablation or microwave ablation assisted resection. As used herein, the phrase “transmission line” generally refers to any transmission medium that can be used for the propagation of signals from one point to another.

[0040] Various embodiments of the present disclosure provide electrosurgical devices for treating tissue and methods of directing electromagnetic radiation to a target volume of tissue. Embodiments may be implemented using electromagnetic radiation at microwave frequencies or at other frequencies. A leaky-wave antenna assembly, according to various embodiments, is capable of radiating energy substantially uniformly along the longitudinal axis of the leaky-wave antenna assembly. Multiple leaky-wave antenna assemblies can be employed in variously arranged configurations. For example, multiple leaky-wave antenna assemblies can be placed parallel to each other to substantially simultaneously ablate a target volume of tissue.

[0041] Various embodiments of the presently disclosed leaky-wave antenna assembly are suitable for microwave ablation and for use to pre-coagulate tissue for microwave ablation assisted surgical resection. Although various methods described hereinbelow are targeted toward microwave ablation and the complete destruction of target tissue, it is to be understood that methods for directing electromagnetic radiation may be used with other therapies in which the target tissue is partially destroyed or damaged, such as, for example, to prevent the conduction of electrical impulses within heart tissue.

[0042] FIG. 4 shows a leaky-wave antenna assembly according to an embodiment of the present disclosure. Referring to FIG. 4, the leaky-wave antenna assembly 400 includes an inner conductor 420 having a length “L” and an outer conductor 460 coaxially surrounding the inner conductor 420 along the length “L”. Leaky-wave antenna assembly 400 may include a dielectric material 440 separating the inner conductor 420 and outer conductor 460. Dielectric material 440 may include ceramics, water, mica, polyethylene, glass, or metal oxides. Leaky-wave antenna assembly 400 may include an electrical short element (not shown) located at the distal end of the device for electrically connecting the inner conductor 420 and the outer conductor 460, such as a solder cap, metal plate or wire.

[0043] The distal portion of the outer conductor 460 is provided with a plurality of apertures for radiating energy. The apertures are configured for radiating energy substantially uniformly along the longitudinal axis of the distal portion of the outer conductor 460, e.g., to provide uniform ablation to the target tissue volume surrounding the leaky-wave antenna assembly 400.

[0044] In the leaky-wave antenna assembly 400 shown in FIG. 4, the sizes of the respective apertures are based on the location of each aperture relative to a distal tip of the leaky-wave antenna assembly 400. The number, shape, size, angle and relative spacing of the apertures may be varied from the configuration depicted in FIG. 4. In the illustrated embodiment, each of the apertures (referred to herein as slots 401, 402, 403 and 404) has a different size and longitudinally extends parallel to the longitudinal axis of the central conductor 420. Slots 401, 402, 403 and 404 are disposed in increasing order of size along the length of the

distal portion of the outer conductor 460, which may increase radiation, since larger slots generally perturb currents more.

[0045] Leaky-wave antenna assembly 400 may be axially rigid to allow for tissue penetration. Leaky-wave antenna assembly 400 may be sufficiently small in diameter to be minimally invasive of the body, which may reduce the preparation time of the patient as might be required for more invasive penetration of the body. Leaky-wave antenna assembly 400 may include a tip portion that is advantageously dimensioned and shaped to facilitate penetration of tissue. The proximal end of the leaky-wave antenna assembly 400 may be coupled to a transmission line that electrically connects the leaky-wave antenna assembly 400 to a microwave energy source.

[0046] FIG. 5 shows another embodiment of a leaky-wave antenna assembly. Leaky-wave antenna assembly 500 shown in FIG. 5 includes an inner conductor 520 and an outer conductor 560 coaxially surrounding the inner conductor 520, and may include a dielectric material 540 separating the inner conductor 520 and the outer conductor 560. Dielectric material 540 may include ferroelectric dielectric materials. The distal portion of the outer conductor 560 is provided with a plurality of apertures for radiating energy. The apertures are configured for radiating energy substantially uniformly along the longitudinal axis of the distal portion of the outer conductor 560. In the leaky-wave antenna assembly 500, radiation can be increased by placing each aperture in a position that causes high perturbation of the currents inside the guiding structure, i.e., transversal to the current lines, so that a high number of current lines is cut and perturbed by the apertures.

[0047] The sizes of the respective apertures and the leaky-wave antenna assembly 500 are based on at least one of the location of each aperture relative to a distal tip of the leaky-wave antenna assembly 500 and the angle of each aperture relative to the longitudinal axis of the central conductor 520. The number, shape, size, angle and relative spacing of the apertures may be varied from the configuration depicted in FIG. 5. In one embodiment, the energy radiated from each of the apertures is substantially the same.

[0048] In the leaky-wave antenna assembly 500 shown in FIG. 5, the apertures (referred to herein as the first, second, third, fourth and fifth slots 501, 502, 503, 504 and 505, respectively) each have a different size. In this embodiment, the first, second, third, fourth and fifth slots 501, 502, 503, 504 and 505 are positioned along the distal portion of the outer conductor 560 in order of increasing size, such that the first slot 501, which is the smallest opening, is disposed furthest from the distal end of the distal portion of the outer conductor 560, and the fifth slot 505, which is the largest opening, is disposed closest to the distal end.

[0049] First, third and fifth slots 501, 503 and 505 longitudinally extend in a first direction at substantially the same angle relative to the longitudinal axis of the central conductor 520. Second and fourth slots 502 and 504 longitudinally extend in a second direction at substantially the same angle relative to the longitudinal axis of the central conductor 520. When the microwave signal propagates inside the leaky-wave antenna assembly 500, it “leaks” out through the first, second, third, fourth and fifth slots 501, 502, 503, 504 and 505, causing substantially uniform radiation along the longitudinal axis of the distal portion of the outer conductor 560.

[0050] FIG. 6 shows another embodiment of a leaky-wave antenna assembly and includes an inner conductor 620 and an outer conductor 660 coaxially surrounding the inner conductor 620. The distal portion of the outer conductor 660 is provided with a plurality of apertures for radiating energy. The apertures (referred to herein as the first, second, third, fourth, fifth and sixth slots 601, 602, 603, 604, 605 and 606) are configured for radiating energy substantially uniformly along the longitudinal axis of the outer conductor 660. In this embodiment, each of the first, second, third, fourth, fifth and sixth slots 601, 602, 603, 604, 605 and 606 are substantially the same size. Leaky-wave antenna assembly 600 may include a dielectric material 640 separating the inner conductor 620 and the outer conductor 660.

[0051] In the leaky-wave antenna assembly 600 shown in FIG. 6, each of the substantially equal-sized first, second, third, fourth, fifth and sixth slots 601, 602, 603, 604, 605 and 606 longitudinally extends at a different angle relative to the longitudinal axis of the central conductor 620. For example, the longitudinal axis of the sixth slot 606 extends substantially perpendicular to the longitudinal axis of the central conductor 620, whereas the longitudinal axis of the first slot 601 is near parallel to the longitudinal axis of the central conductor 620. As the microwave signal propagates inside the leaky-wave antenna assembly 600, it “leaks” out through the first, second, third, fourth, fifth and sixth slots 601, 602, 603, 604, 605 and 606, causing substantially uniform radiation along the longitudinal axis of the distal portion of the outer conductor 660.

[0052] FIG. 7 shows another embodiment of a leaky-wave antenna assembly and includes an inner conductor 720, an outer conductor 760 coaxially surrounding the inner conductor, a plurality of apertures (referred to herein as slots 701, 702, 703 and 704, respectively) for radiating energy, and may include a dielectric material 740 separating the inner and outer conductors. Leaky-wave antenna assembly 700 is similar to the leaky-wave antenna assembly 400 illustrated in FIG. 4, except that the leaky-wave antenna assembly 700 further includes inclusion elements 711, 712, 713 and 714 extending inwardly from the outer conductor 760. Each inclusion element 711, 712, 713 and 714 extends inwardly toward the inner conductor 720 at an angle relative to a plane substantially coextensive with the corresponding one of the slots 701, 702, 703 or 704.

[0053] Inclusion elements 711, 712, 713 and 714 each have a size, a shape, and an edge disposed substantially adjacent to an edge of a corresponding one of the slots 701, 702, 703 or 704. The size, shape and/or angle of each inclusion element 711, 712, 713 and 714 may be based on a wavelength of the energy to be radiated along the outer conductor 760. The size, shape and/or angle of each inclusion element 711, 712, 713 and 714 may be based on the location of the corresponding one of the slots 701, 702, 703 or 704 relative to the distal tip of the leaky-wave antenna assembly 700.

[0054] FIG. 8A is an enlarged view of the slot 701 and the inclusion element 711 illustrated in FIG. 7 shown with example dimensions of the slot 701 and the inclusion element 711. The slot 701 has a length “L1” and a width “W1”, and the inclusion element 711 has a length “L2” and a width “W1”. The angle formed between the inclusion element 711 and a plane substantially coextensive with the corresponding one of the slot 701 is indicated by the arc labeled “A”. In the leaky-wave antenna assembly 700 shown

in FIG. 7, the inclusion elements 711, 712, 713 and 714 each have equal width “W1”; a first subset of the inclusion elements 711 and 713 have equal length “L2”; and a second subset of inclusion elements 712 and 714 have an equal length that is different than the length “L2” of the first set of inclusion elements. The lengths and widths of the apertures and inclusion elements may be varied from the configuration depicted in FIGS. 7 and 8A.

[0055] FIG. 8B is an enlarged view of the slot 701 and the inclusion element 711 illustrated in FIG. 7 shown with a dielectric pocket “P” having an upper surface 801, a lower surface 802 opposed to the upper surface 801, a first side surface 811, a second side surface 812, and a third side surface 813. In the illustrated embodiment, the dielectric pocket “P” has a wedge-like shape, wherein each of the first and second side surfaces 811, 812 has a substantially rectangular shape with the first side surface 811 having a length “L1” and a width “W1” and the second side surface 812 having a length “L2” and a width “W1”. The shape and volume of the dielectric pocket “P” may be varied from the configuration depicted in FIG. 8B.

[0056] Dielectric pocket “P” may be formed of material with a dielectric constant different than the dielectric constant of the dielectric material 740. For example, the dielectric pocket “P” may be formed of a material with a dielectric constant higher than the dielectric constant of the dielectric material 740, which may tend to concentrate more electric fields within the volume of the dielectric pocket “P”. Dielectric pocket “P” may be formed of a material with a dielectric constant lower than the dielectric constant of the dielectric material 740, which may tend to lessen the electric fields within the volume of the dielectric pocket “P”. Dielectric pocket “P” may be configured to assist in uniformity of leaky behavior of the leaky-wave antenna assembly 700. For example, respective widths of the inclusion elements may be larger, smaller and/or substantially equal to the width “W1” of the slots 701, 702, 703 and 704. It is contemplated herein that some apertures may not be provided with an inclusion element and/or some apertures may be provided with a plurality of inclusion elements. Inclusion elements may be integrally formed with the outer conductor 760, for example, by punching, bending and/or cutting of the material of the outer conductor 760, such that the apertures and the inclusion elements are commonly formed. Alternatively, the inclusion elements may be separately fabricated from any suitable electrically conductive materials and attached to an inner diametric surface of the outer conductor 760, e.g., by solder or adhesive.

[0057] FIG. 9 shows another embodiment of a leaky-wave antenna assembly and includes an inner conductor 920, an outer conductor 960 coaxially surrounding the inner conductor, and a plurality of apertures (referred to herein as first, second, third and fourth slots 901, 902, 903 and 904, respectively) for radiating energy. Leaky-wave antenna assembly 900 may include a dielectric material 940 separating the inner and outer conductors. Leaky-wave antenna assembly 900 is also similar to the leaky-wave antenna assembly 400 illustrated in FIG. 4, except that the leaky-wave antenna assembly 900 further includes inclusion elements 911, 912, 913 and 914 extending inwardly from the outer conductor 960. Inclusion elements 911, 912, 913 and 914 are similar to the inclusion elements 711, 712, 713 and 714 shown in FIG. 7, except that the inclusion elements 911, 912, 913 and 914 are respectively disposed substantially

adjacent to a proximal edge of the slots **901**, **902**, **903** and **904**, i.e., instead of a distal edge thereof as shown in FIG. 7. Leaky-wave antenna assembly **900** may include dielectric pockets (not shown), e.g., similar to the dielectric pocket “P” shown in FIG. 8B, which may be formed of a material with a dielectric constant different than the dielectric constant of the dielectric material **940**.

[0058] FIG. 10 shows yet another embodiment of a leaky-wave antenna assembly and includes an inner conductor **1020**, an outer conductor **1060** coaxially surrounding the inner conductor, and a plurality of apertures (herein referred to as first, second, third, fourth and fifth slots **1001**, **1002**, **1003**, **1004** and **1005**, respectively) for radiating energy, and may include a dielectric material **1040** separating the inner and outer conductors. Leaky-wave antenna assembly **1000** further includes a number of inclusion elements **1011**, **1012**, **1013**, **1014** and **1015** extending inwardly from the outer conductor **1020**. In this embodiment, the inclusion elements **1011**, **1012**, **1013**, **1014** and **1015** each have a different size.

[0059] In the leaky-wave antenna assembly **1000** shown in FIG. 10, each of the first, second, third, fourth and fifth slots **1001**, **1002**, **1003**, **1004** and **1005** longitudinally extends at a different angle relative to the longitudinal axis of the central conductor **1020**. A first subset of the inclusion elements **1011**, **1012**, **1013** and **1014**, are respectively disposed substantially adjacent to a distal edge of the slots **1001**, **1002**, **1003** and **1004**, and a second subset, i.e., inclusion element **1015**, is disposed substantially adjacent to a proximal edge of the slot **1005**. Leaky-wave antenna assembly **1000** may include dielectric pockets (not shown), e.g., similar to the dielectric pocket “P” shown in FIG. 8B, which may be formed of a material with a dielectric constant different than the dielectric constant of the dielectric material **1040**.

[0060] FIG. 11 shows yet another embodiment of a leaky-wave antenna assembly and includes an inner conductor **1120**, an outer conductor **1160** coaxially surrounding the inner conductor, and a plurality of apertures (referred to herein as slots **1101**, **1102**, **1103**, **1104**, **1105** and **1106**, respectively) for radiating energy, and may include a dielectric material **1140** separating the inner and outer conductors. Leaky-wave antenna assembly **1100** further includes a number of inclusion elements **1111**, **1112**, **1113**, **1114**, **1115** and **1116** extending inwardly from the outer conductor **1120**.

[0061] Each inclusion element **1111**, **1112**, **1113**, **1114**, **1115** and **1116** extends inwardly toward the inner conductor **1120** at an angle relative to a plane substantially coextensive with the slots **1101**, **1102**, **1103**, **1104**, **1105** and **1106**, respectively. The size, shape and/or angle of each inclusion element **1111**, **1112**, **1113**, **1114**, **1115** and **1116** may be based on a wavelength of the energy to be radiated along the length of the outer conductor **1160**. The size, shape and/or angle of each inclusion element **1111**, **1112**, **1113**, **1114**, **1115** and **1116** may be based on the location of the corresponding one of the slots **1101**, **1102**, **1103**, **1104**, **1105** and **1106** relative to the distal tip of the leaky-wave antenna assembly **700**. As the microwave signal propagates inside the leaky-wave antenna assembly **1100**, it “leaks” out through the slots **1101**, **1102**, **1103**, **1104**, **1105** and **1106**, causing substantially uniform radiation along the longitudinal axis of the distal portion of the outer conductor **1160**. Leaky-wave antenna assembly **1100** may include dielectric pockets (not shown), e.g., similar to the dielectric pocket “P” shown in FIG. 8B,

which may be formed of a material with a dielectric constant different than the dielectric constant of the dielectric material **1140**.

[0062] FIGS. 12A and 12B show a leaky-wave antenna assembly **1200** including a moveable sleeve member **1220** located at a periphery of the outer conductor **1260** coaxially with the outer conductor **1260**. Sleeve member **1220** is adapted to be slideably moveable along the periphery of the leaky-wave antenna assembly **1200** between a first position, in which a first portion **1240A** of the distal portion of the outer conductor **1260** is exposed, and a second position, in which a second portion **1240B** larger than the first portion **1240A** of the distal portion of the outer conductor **1260** is exposed. For example, when the sleeve member **1220** is in the first position shown in FIG. 12A, a first set of apertures **1201**, **1202** and **1203**, are exposed, and when the sleeve member **1220** is in the second position shown in FIG. 12B, a second set of apertures **1201**, **1202**, **1203**, **1204** and **1205** are exposed. When the leaky-wave antenna assembly **1200** is operated with the sleeve member in the first position, the energy is applied to a first portion of the target volume of tissue “T”, and when the leaky-wave antenna assembly **1200** is operated with the sleeve member **1220** in the second position, the energy is applied to a second portion larger than the first portion of the target volume of tissue “T”.

[0063] Sleeve member **1220** shown in FIGS. 12A and 12B is a substantially cylindrical shaped structure having an inner diameter “DI”, which is larger than an outer diameter “DO” of the outer conductor **1260**. The sleeve member **1220** is slideably movable to various positions such that any suitable number of apertures may be exposed. The number of apertures to be exposed may be based on various factors, such as, for example, the volume of target tissue to be treated, the desired procedure, the wavelength of the energy to be radiated, and the shape and dimensions of the apertures.

[0064] FIG. 13A shows a leaky-wave antenna **1300** including a moveable sleeve member **1320** located at a periphery of the outer conductor **1360** coaxially with the outer conductor **1360**. Sleeve member **1320** is adapted to be rotationably moveable and slideably moveable along the periphery of the leaky-wave antenna assembly **1300** to various positions or various rotation positions to vary slot openings with rotation angle. Sleeve member **1320** includes a plurality of apertures **1321**, **1322**, **1323**, **1324** and **1325** and can be positioned relative to the outer conductor **1360** such that any suitable number of slot openings may be exposed. For example, the sleeve member **1320** is moveable such that the apertures **1321**, **1322**, **1323**, **1324** and **1325** are respectively positioned in alignment with the slots **1301**, **1302**, **1303**, **1304** and **1305** in the outer conductor **1360** to create leaky-wave openings. The number, shape and pattern of apertures in the sleeve member **1320** may be varied from the configuration depicted in FIG. 13 and may be selectable by a user, e.g., for a particular antenna deposition pattern.

[0065] FIG. 14 is a flowchart illustrating a method of directing energy to a target volume of tissue. In step **1410**, a leaky-wave antenna assembly, e.g., **400**, is positioned for the delivery of energy to the target volume of tissue. Leaky-wave antenna assembly **400** may be inserted directly into tissue (e.g., as shown in FIGS. 12A and 12B), inserted through a lumen, e.g., a vein, needle or catheter, placed into the body during surgery by a clinician, or positioned in the body by other suitable methods known in the art.

[0066] In step 1420, energy from an energy source is transmitted to the leaky-wave antenna assembly. For example, the energy source may be any suitable electrosurgical generator for generating an output signal. In one embodiment, the energy source is a microwave energy source.

[0067] In step 1430, the energy is applied through a plurality of radiating apertures, e.g., 401, 402, 403 and 404, in a distal portion of the leaky-wave antenna assembly. The radiating apertures 401, 402, 403 and 404 are configured for radiating energy along the longitudinal axis of the leaky-wave antenna assembly 400. For example, the size and/or the angle of each aperture relative to the inner conductor 420 of the leaky-wave antenna assembly 400 may be varied in relation to the other apertures such that the energy radiated along the leaky-wave antenna assembly 400 is substantially uniform. For example, at least a subset of the radiating apertures may extend at different angles relative to the longitudinal axis of the leaky-wave antenna assembly. The size and/or the angle of each aperture relative to the inner conductor 420 may be varied in relation to the other apertures such that the energy radiated along the leaky-wave antenna assembly 400 may have a substantially pear shape, hour-glass shape or other shape.

[0068] A typical helical antenna is illustrated in FIG. 15 and includes a conducting wire 1500 that is coiled to form a helix having an axis 1520 and backed by a conducting ground plane 1510. The basic geometrical parameters that define a helical antenna include the diameter  $D$  and circumference  $C$  of the helix, where  $C=\pi D$ , the number of turns  $N$  of the helix, the center-to-center spacing  $S$  between turns, the pitch angle  $\alpha$ , where  $\alpha=\arctan(S/\pi D)$ , and the axial length  $A$  of the helix, where  $A=N \times S$ . When the circumference of the helix is small compared with the axial length and the wavelength, the helical antenna radiates in the normal mode (similar to dipole antenna radiation). When the helix circumference is about one wavelength, the helical antenna operates in the axial mode. Typically, a helical antenna radiates in the normal mode when  $C < 0.4\lambda$  ( $\lambda$  is the wavelength) and in the axial mode for approximately  $0.75\lambda < C < 1.3\lambda$ .

[0069] FIG. 16 shows an embodiment of a dual antenna assembly including a leaky-wave antenna assembly and a helical antenna assembly. The leaky-wave antenna assembly 1650 shown in FIG. 16 is similar to the leaky-wave antenna assembly 400 of FIG. 4 and further description thereof is omitted in the interests of brevity. The helical antenna assembly 1690 shown in FIG. 16 includes a helical antenna radiating section 1660 and a tip portion 1665. Tip portion 1665 is configured for penetrating tissue. Although the surfaces of the tip portion 1665 shown in FIG. 16 are generally flat, the surfaces of the tip portion 1665 according to various embodiments may be curved or may include a combination of flat, sloped or curved portions. The shape and size of the tip portion 1665 may be varied from the configuration depicted in FIG. 16. The helical antenna radiating section 1660 includes a helical antenna element 1610.

[0070] FIG. 17 shows a portion of the helical antenna assembly of FIG. 16 taken along the lines II-II. Referring to FIG. 17, the helical antenna radiating section 1660 includes a distal end 1764. Helical antenna assembly 1600 can be operated in the axial mode to perform a procedure on a first portion of a target volume of tissue, wherein the first portion

of the tissue is located distal to end 1764 of the helical antenna assembly 1600. Helical antenna assembly 1600 can be operated in the normal mode to perform a second procedure on a second portion of the target volume of tissue, wherein the second portion is located substantially adjacent to the helical antenna radiating section 1660. Various sequences of axial and normal modes of operation may be utilized depending on the particular application of the helical antenna assembly 1600.

[0071] The helical antenna radiating section 1660 further includes a sleeve portion 1721 located at the periphery of the helical antenna element 1610 coaxially with the helical antenna element 1610, and a cavity 1780 located to the interior of the helical antenna element 1610. In an embodiment, the sleeve portion 1721 is formed of a dielectric material and may include a material that has variable dielectric constant, or adjustable dielectric constant, so that effective wavelengths will vary between the axial mode and the normal mode of operation.

[0072] FIG. 18 is a cross-sectional view of the helical antenna radiating section 1660 of FIG. 17. FIG. 18 shows the helical antenna radiating section 1660 including the helical antenna element 1610 enclosed by a first dielectric material 1721. First dielectric material 1721 may include ferroelectric dielectric materials, which through applied DC voltage may allow control of the depth and spread of the power deposition pattern.

[0073] FIG. 19 is a cross-sectional view of the helical antenna radiating section of FIG. 17 shown with a dielectric material located in an interior of the helical antenna element. Helical antenna radiating section 1800 is similar to the helical antenna radiating section 1600 shown in FIG. 18, except that the helical antenna radiating section 1800 includes a second dielectric material 1880 disposed to the interior of the helical antenna element 1610, i.e., instead of the cavity 1780. Second dielectric material 1880 may include ferroelectric dielectric materials.

[0074] FIG. 20 shows another embodiment of a dual antenna assembly. The dual antenna assembly 1900 illustrated in FIG. 20 includes a proximal portion 1950 and a distal portion 1980. Proximal portion 1950 includes a leaky-wave antenna assembly having a plurality of slots 1901, 1902, 1903, 1904 and 1905. Distal portion 1980 includes either a dipole or monopole antenna assembly. The arrows in FIG. 20 show the leaky radiation along the proximal portion 1950 and the dipole (or monopole) radiation on the distal portion 1980.

[0075] FIG. 21 shows yet another embodiment of a dual antenna assembly. Dual antenna assembly 2000 includes a leaky-wave antenna assembly 2050 and a microstrip antenna assembly 2070. Leaky-wave antenna assembly 2050 includes an outer conductor 2060, which is provided with a plurality of slots 2001, 2002, 2003 and 2004 for radiating energy, and an inner conductor 2020. Microstrip antenna assembly 2070 includes a lower conductor 2066, which is electrically connected to the outer conductor 2060 of the leaky-wave antenna assembly 2050, and a central conductor 2022, which is electrically connected to the inner conductor 2020 of the leaky-wave antenna assembly 2050.

[0076] FIG. 22 is a cross-sectional view of the distal portion of the dual antenna assembly illustrated in FIG. 21. As shown in FIG. 22, a dielectric material 2030 is disposed adjacent to the lower conductor 2066.



[0077] FIG. 23 is a flowchart illustrating a method of directing energy to a target volume of tissue. In step 2310, a dual antenna assembly, e.g., 1600, is positioned for delivery of energy to the target volume of tissue.

[0078] In step 2320, energy from an energy source is transmitted to the dual antenna assembly 1600. The energy source may be an electrosurgical generator for generating an output signal. In one embodiment, the energy source is a microwave energy source.

[0079] In step 2330, a first antenna subassembly is operated, the first antenna subassembly being a leaky-wave antenna assembly, e.g., 400, extending through a proximal portion of the dual antenna assembly, whereby a first portion of the energy is radiated through a plurality of apertures in the leaky-wave antenna assembly 400, the apertures being configured for radiating energy substantially uniformly along a longitudinal axis of the leaky-wave antenna assembly 400.

[0080] In step 2340, a second antenna subassembly, e.g., 1660, is operated, the second antenna subassembly 1660 being electrically coupled to the first antenna subassembly 400 and disposed in a distal portion of the dual antenna assembly 1600.

[0081] In various embodiments of the presently disclosed leaky-wave antenna assemblies, uniform radiation with a leaky-wave coaxial cable is achieved by compensating for signal attenuation along the cable (stronger signal proximally, close to generator, and weaker signal distally) by varying slots size and/or slot direction so that smaller slots and/or slots angled more parallel to the cable axis are placed proximally (where the signal is stronger), while larger slots and/or slots transverse to the cable axis are placed distally (where the signal has been attenuated more), with gradual change in slot size and/or direction in between.

[0082] Although embodiments have been described in detail with reference to the accompanying drawings for the purpose of illustration and description, it is to be understood that the inventive processes and apparatus are not to be construed as limited thereby. It will be apparent to those of ordinary skill in the art that various modifications to the foregoing exemplary embodiments may be made without departing from the scope of the disclosure.

1-16. (canceled)

17. A microwave ablation probe for directing energy to tissue, comprising:

an inner conductor;

an outer conductor coaxially disposed about at least a portion of the inner conductor, the inner conductor and the outer conductor defining a first longitudinal axis, the outer conductor including a plurality of apertures defined therein, each of the plurality of apertures defining a second longitudinal axis that is disposed at an angle relative to the first longitudinal axis, each of the angles being different from each other;

a dielectric material disposed between the inner conductor and the outer conductor; and

a sleeve member coaxially disposed about at least a portion of the outer conductor and movable relative to the outer conductor, the sleeve member configured to selectively expose a distal portion of the outer conductor to adjust delivery of energy to tissue.

18. The microwave ablation probe according to claim 17, wherein the outer conductor includes a plurality of inclusion

elements disposed substantially adjacent to an edge of a corresponding aperture of the plurality of apertures.

19. The microwave ablation probe according to claim 18, wherein each of the plurality of inclusion elements extends beyond the edge of the corresponding aperture and inwardly toward the inner conductor at an angle relative to a plane substantially coextensive with the corresponding aperture.

20. The microwave ablation probe according to claim 18, wherein each of the plurality of inclusion elements have the same dimensions as the corresponding aperture.

21. The microwave ablation probe according to claim 17, wherein each of the apertures has a different size.

22. The microwave ablation probe according to claim 17, wherein the sleeve member is at least one of rotationally or longitudinally moveable relative to the outer conductor.

23. The microwave ablation probe according to claim 17, wherein the sleeve member includes a plurality of sleeve apertures.

24. The microwave ablation probe according to claim 23, wherein the sleeve member is movable between a first position in which the plurality of sleeve apertures are substantially aligned with the plurality of apertures and a second position in which at least a portion of the plurality of apertures are enclosed by the sleeve member.

25. The microwave ablation probe according to claim 19, wherein each of the inclusion elements has a size and a shape, and at least one of the size, the shape, or the angle of each inclusion element controls a wavelength of the energy radiated along the inner and outer conductors.

26. The microwave ablation probe according to claim 25, wherein at least one of the size, the shape, and the angle of each inclusion element is based on a distance of the corresponding aperture relative to a distal tip of the microwave ablation probe.

27. The microwave ablation probe according to claim 19, wherein the dielectric material has a first dielectric constant and each of the inclusion elements includes a second dielectric material having a second dielectric constant different than the first dielectric constant.

28. A system for directing energy to tissue, comprising: a source of microwave energy configured to generate a microwave waveform; and

an antenna assembly coupled to the source of microwave energy, the antenna assembly including:

an inner conductor;

an outer conductor coaxially disposed about at least a portion of the inner conductor, the inner conductor and the outer conductor defining a first longitudinal axis, the outer conductor including a plurality of apertures defined therein, each of the plurality of apertures defining a second longitudinal axis that is disposed at an angle relative to the first longitudinal axis, each of the angles being different from each other;

a dielectric material disposed between the inner conductor and the outer conductor; and

a sleeve member coaxially disposed about at least a portion of the outer conductor and movable relative to the outer conductor, the sleeve member configured to selectively expose a distal portion of the outer conductor to adjust delivery of energy to tissue.

29. The system according to claim 28, wherein the outer conductor includes a plurality of inclusion elements dis-

posed substantially adjacent to an edge of a corresponding aperture of the plurality of apertures.

**30.** The system according to claim **29**, wherein each of the plurality of inclusion elements extends beyond the edge of the corresponding aperture and inwardly toward the inner conductor at an angle relative to a plane substantially coextensive with the corresponding aperture.

**31.** The system according to claim **28**, wherein each of the apertures has a size and extends at an angle relative to a longitudinal axis of the outer conductor and at least one of the size and the angle of each aperture is varied in relation to the other apertures.

**32.** The system according to claim **28**, wherein the sleeve member is at least one of rotationally or longitudinally moveable relative to the outer conductor.

**33.** The system according to claim **28**, wherein the sleeve member includes a plurality of sleeve apertures.

**34.** The system according to claim **33**, wherein the sleeve member is movable between a first position in which the

plurality of sleeve apertures are substantially aligned with the plurality of apertures and a second position in which at least a portion of the plurality of apertures are enclosed by the sleeve member.

**35.** The system according to claim **30**, wherein each of the inclusion elements has a size and a shape, and at least one of the size, the shape, and the angle of each inclusion element controls a wavelength of the microwave waveform.

**36.** The system according to claim **35**, wherein at least one of the size, the shape, and the angle of each inclusion element is based on a distance of the corresponding aperture relative to a distal tip of the antenna assembly.

**37.** The system according to claim **29**, wherein the dielectric material has a first dielectric constant and wherein each of the inclusion elements includes a second dielectric material having a second dielectric constant different than the first dielectric constant.

\* \* \* \* \*