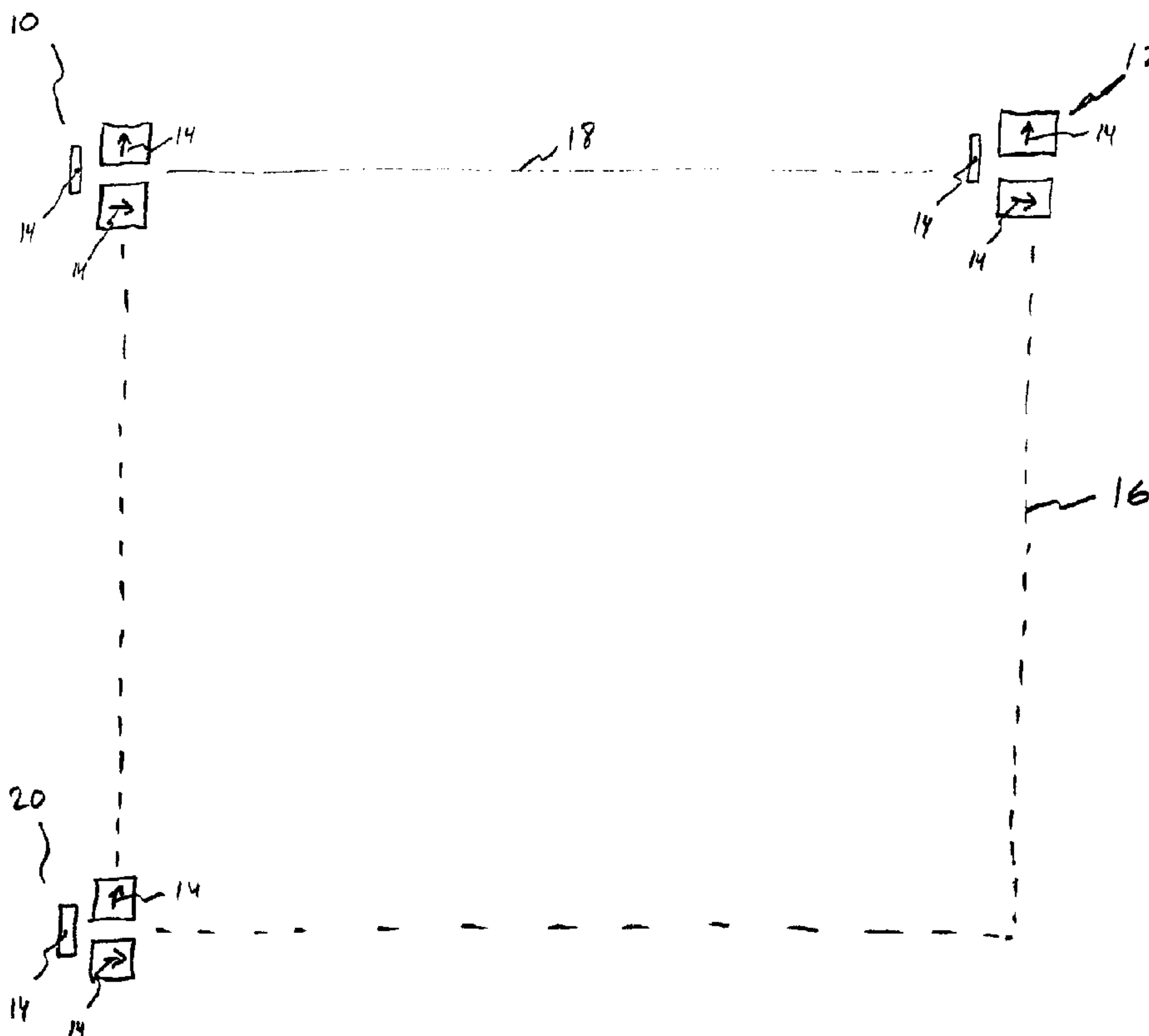




(86) Date de dépôt PCT/PCT Filing Date: 2001/11/22  
 (87) Date publication PCT/PCT Publication Date: 2002/05/30  
 (85) Entrée phase nationale/National Entry: 2003/05/20  
 (86) N° demande PCT/PCT Application No.: US 2001/044071  
 (87) N° publication PCT/PCT Publication No.: 2002/043045  
 (30) Priorité/Priority: 2000/11/22 (60/252,556) US

(51) Cl.Int.<sup>7</sup>/Int.Cl.<sup>7</sup> G09G 5/00, G06K 11/18, G06K 11/06  
 (71) Demandeur/Applicant:  
CIRQUE CORPORATION, US  
 (72) Inventeurs/Inventors:  
LEE, DANIEL, US;  
TAYLOR, BRIAN, US;  
HARNEY, MICHAEL P., US;  
GYORI, BENJAMIN JAZEF, US  
 (74) Agent: OYEN WIGGS GREEN & MUTALA

(54) Titre : DISPOSITIF D'ENTREE DE STYLET A AIMANT PERMANENT  
 (54) Title: STYLUS INPUT DEVICE UTILIZING A PERMANENT MAGNET



(57) Abrégé/Abstract:

A stylus (30) that operates utilizing magnetic fields, wherein a permanent magnet (32) is disposed within a passive stylus that is detectable by a plurality of magnetic sensors (10, 12) that remove the magnetic field of the stylus from the earth's relative magnetic field to thereby obtain vectors that are used in a triangulation equation to determine the location of the stylus (30) in two or three dimensions, depending upon the number of magnetic sensors (10, 12) that are used, wherein one set of magnetic sensors can be used as a reference for earth's magnetic field, and wherein each of the magnetic sensors includes a polarizing coil to change direction of sensitivity (14), a null coil (42) and a flipping coil (44).

## (12) INTERNATIONAL APPLICATION PUBLISHED UNDER THE PATENT COOPERATION TREATY (PCT)

CORRECTED VERSION

(19) World Intellectual Property Organization  
International Bureau(43) International Publication Date  
30 May 2002 (30.05.2002)

PCT

(10) International Publication Number  
WO 02/043045 A1(51) International Patent Classification<sup>7</sup>: G09G 5/00,  
G06K 11/06, 11/18Sandy, UT 84092 (US). HARNEY, Michael, P.; 880 East  
3400 North, Layton, UT 84040 (US). GYORI, Benjamin,  
Jazef; 95 East 550 South, Farmington, UT 84025 (US).

(21) International Application Number: PCT/US01/44071

(74) Agents: O'BRYANT, David, W. et al.; Morriss, Bateman,  
O'Bryant & Compagni, P.C., Suite 700, 136 South Main  
Street, Salt Lake City, UT 84101 (US).(22) International Filing Date:  
22 November 2001 (22.11.2001)

(25) Filing Language: English

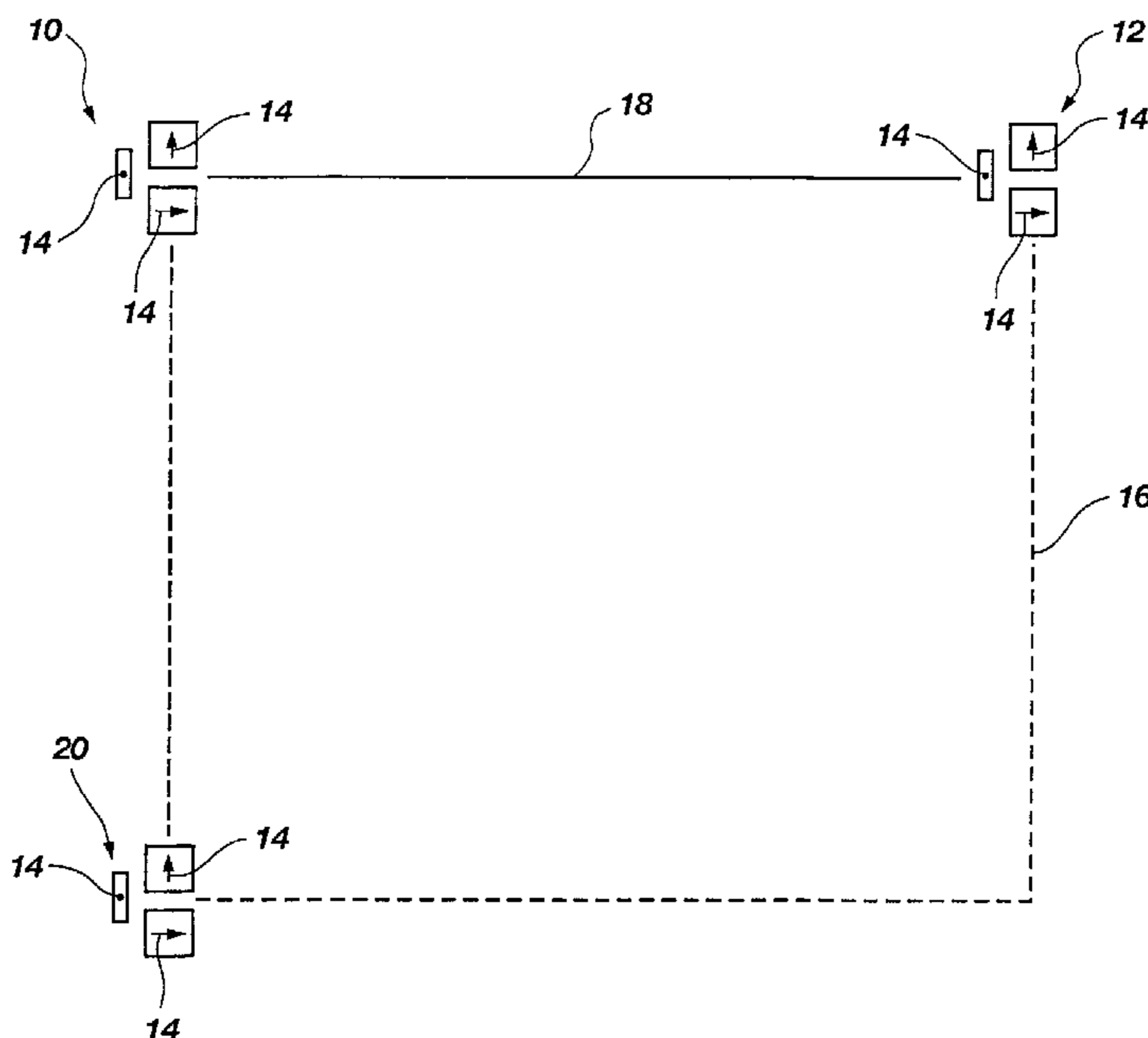
(81) Designated States (*national*): AE, AG, AL, AM, AT, AU,  
AZ, BA, BB, BG, BR, BY, BZ, CA, CH, CN, CO, CR, CU,  
CZ, DE, DK, DM, DZ, EC, EE, ES, FI, GB, GD, GE, GH,  
GM, HR, HU, ID, IL, IN, IS, JP, KE, KG, KP, KR, KZ, LC,  
LK, LR, LS, LT, LU, LV, MA, MD, MG, MK, MN, MW,  
MX, MZ, NO, NZ, OM, PH, PL, PT, RO, RU, SD, SE, SG,  
SI, SK, SL, TJ, TM, TR, TT, TZ, UA, UG, UZ, VN, YU,  
ZA, ZW.

(26) Publication Language: English

(30) Priority Data:  
60/252,556 22 November 2000 (22.11.2000) US(71) Applicant: CIRQUE CORPORATION [US/US]; 2463  
South 3850 West, Suite A, Salt Lake City, UT 84120 (US).(84) Designated States (*regional*): ARIPO patent (GH, GM,  
KE, LS, MW, MZ, SD, SL, SZ, TZ, UG, ZM, ZW),  
Eurasian patent (AM, AZ, BY, KG, KZ, MD, RU, TJ, TM),  
European patent (AT, BE, CH, CY, DE, DK, ES, FI, FR,(72) Inventors: LEE, Daniel; 1970 Laird Drive, Salt Lake City,  
UT 84105 (US). TAYLOR, Brian; 15 Rollingwood Lane,

[Continued on next page]

(54) Title: STYLUS INPUT DEVICE UTILIZING A PERMANENT MAGNET



(57) Abstract: A stylus (30) that operates utilizing magnetic fields, wherein a permanent magnet (32) is disposed within a passive stylus that is detectable by a plurality of magnetic sensors (10, 12) that remove the magnetic field of the stylus from the earth's relative magnetic field to thereby obtain vectors that are used in a triangulation equation to determine the location of the stylus (30) in two or three dimensions, depending upon the number of magnetic sensors (10, 12) that are used, wherein one set of magnetic sensors can be used as a reference for earth's magnetic field, and wherein each of the magnetic sensors includes a polarizing coil to change direction of sensitivity (14), a null coil (42) and a flipping coil (44).



WO 02/043045 A1

**WO 02/043045 A1**



GB, GR, IE, IT, LU, MC, NL, PT, SE, TR), OAPI patent  
(BF, BJ, CF, CG, CI, CM, GA, GN, GQ, GW, ML, MR,  
NE, SN, TD, TG).

**(15) Information about Correction:**

see PCT Gazette No. 07/2003 of 13 February 2003, Sec-  
tion II

**Published:**

— *with international search report*

**(48) Date of publication of this corrected version:**

13 February 2003

*For two-letter codes and other abbreviations, refer to the "Guid-  
ance Notes on Codes and Abbreviations" appearing at the begin-  
ning of each regular issue of the PCT Gazette.*

**STYLUS INPUT DEVICE UTILIZING A PERMANENT MAGNET****BACKGROUND****5 The Field of the Invention**

This invention relates generally to input devices for electronic information devices. More specifically, the present invention provides a stylus that is operable in two or three dimensions, and which is utilized to provide input such as lines that represent movement of the stylus within a field of operation, or cursor control for computers and portable information appliances such as personal digital assistants (PDAs) or other types of electronic appliances such as mobile telephones.

**Background of the Invention**

The state of the art of input devices utilizing a stylus is generally characterized by digitizing tablets or a touchpad. A digitizing tablet is generally a large surface that is used to input data with a stylus that is coupled to the tablet or touchpad. For example, a cable connects the stylus to the tablet, and movement of the stylus is detected or tracked as it moves across the surface of the tablet. The movement is typically portrayed as lines on a display.

The basis of operation for most stylus-based tablets is reliance upon electromagnetic sensors. A magnetic field is formed by electric current that is flowing in a loop. The pen has a coil that picks up this magnetic field and sends it back to a convertor that determines the X and Y position from this data. This type of pen generally requires a tether between



the pen and a base device to transfer the data, or the use of an active pen that is battery powered and generates some type of signal that is detectable by the touchpad.

5           It would therefore be an advantage over the prior art to provide a pen or stylus-based system for data input or cursor control which does not require a tethered stylus or an active pen. It would also be advantageous if the stylus did not require an internal  
10 power source to operate.

The prior art also describes using a stylus with personal digital assistants (PDAs). When a stylus requires pressure in order to be detectable, the writing surface of the PDA can be damaged. In  
15 addition, the writing area for the stylus is typically very small. It is also difficult to use a stylus when there is no visual feedback or "inking trail" to show the writer what has been written. Inking can also be difficult if there is a delay between stylus movement  
20 and the appearance on a display screen of what is being written.

Accordingly, it would be an advantage over the prior art to provide an off-screen inking surface to prevent damage to a PDA screen. It would also be an  
25 advantage to provide a larger writing surface for the PDA, as well as visual feedback that is rapid.

The prior art also fails to teach any type of stylus which can operate without making contact with a surface that can detect the presence of the stylus.  
30 In other words, the surface being written on is some surface that is capable of detecting the stylus. Accordingly, it would be an advantage to be able to

detect and track movement of a stylus on a surface, where the surface is not a stylus detection surface.

The prior art also teaches that some type of sensing surface must be used with a stylus.

5 Accordingly, it would be an advantage over the prior art to provide a stylus which does not require any sensing surface in order to be detectable. It would also be an advantage to therefore enable a stylus to be detectable as it moves within three dimensions.

10 Another aspect to be addressed is the ability to turn writing on and off. Typically, this type of function has required a sensitive surface, possibly a tether from the pen to another device, or an active pen. Accordingly, it would be an advantage over the  
15 prior art to provide a stylus that can be actuated to turn on and off writing on an associated display, where the stylus is a passive device that does not write on a special sensing surface, and is not physically tethered to another device.

20 A final aspect of the invention is the ability to implement a stylus for use in a very small area. Consider the mobile telephone user that wants to input and email message and send it. It is a tedious and time consuming task with state of the art input  
25 options on cell phones. It would be an advantage over the prior art to provide a very small keyboard that is actuated by the stylus so that it can be used in mobile situations, and with relatively small devices.

30 **Summary of Invention:**

It is an object of the present invention to provide a passive stylus that operates in two or three dimensions.

It is another object to provide a passive stylus that only requires a permanent magnet disposed therein.

5 It is another object to provide a passive stylus that can provide signals indicative of touchdown and pressure.

10 It is another object to provide a passive stylus that can provide "start" and "stop" writing signals to a display device, wherein the signals are actuated by normal writing movements and actions.

It is another object to provide a passive stylus that can include an inking cartridge that provides real inking of the stylus on paper when used off-screen.

15 It is another object to provide a passive stylus that can operate in three dimensions by providing a sufficient number of sensors to provide a three dimensional detection volume.

20 It is another object to provide a passive stylus that increases magnetic field strength to thereby function as an indicator of a changing signal.

25 It is another object to provide a passive stylus that rotates a permanent magnet stored within a pen body to thereby change polarity and provide a digital "on" and "off" signal.

It is another object to provide a passive stylus that can detect rotation of the stylus.

30 It is another object to provide a passive stylus that can be turned over to perform an erasing function on a display device.

It is another object to provide a passive stylus that can be incorporated into a mechanical pencil as well as with an inking cartridge.



It is another object to provide a passive stylus that can be utilized with a small keypad, wherein the keypad detects contact of the passive stylus with keys on the keypad.

5 It is another object to provide an active stylus that provides a signal to a display device to thereby provide pressure information so as to be able to draw with varying degrees of shading.

10 In a preferred embodiment, the present invention is a stylus that operates utilizing magnetic fields, wherein a permanent magnet is disposed within a passive stylus that is detectable by a plurality of magnetic sensors that subtract the magnetic field of the stylus from the earth's relative magnetic field to  
15 obtain vectors that are used in a triangulation equation to determine the location of the stylus within a writing area.

In a first aspect of the invention, each pair of magnetic sensors provides a vector, wherein two pairs  
20 provides vector information for two dimensions, and three pairs provide vector information for three dimensions.

In a second aspect of the invention, the three pairs of magnetic sensors are disposed in three of  
25 four corners in the plane of a virtual rectangle.

In a third aspect of the invention, one of the three pairs of magnetic sensors functions as a reference for earth's magnetic field.

In a fourth aspect of the invention, each of the  
30 magnetic sensors includes a polarizing coil to change direction of sensitivity, a null coil and a flipping coil.



In a fifth aspect of the invention, a "start" and "stop" signal generated by the passive stylus are detectable by the magnetic sensors by rapid movement of a permanent magnet within the stylus body.

5        These and other objects, features, advantages and alternative aspects of the present invention will become apparent to those skilled in the art from a consideration of the following detailed description taken in combination with the accompanying drawings.

10

**Description of the Drawings:**

Figure 1 is a top elevational view of magnetic field sensors set out in sets to provide an area of sensitivity that is two dimensional when two sets are used, and three dimensional when three sets are used.

15

Figure 2A is an example of an area of sensitivity of the present invention.

Figure 2B is an example of another area of sensitivity of the present invention.

20

Figure 2C is an example of another area of sensitivity of the present invention.

Figure 3 is a profile cut-away view of a stylus.

Figure 4 is circuit diagram of a magnetic field sensor.

25

Figure 5 is schematic diagram of components of the present invention.

Figure 6 is a profile cut-away view of two views of a stylus showing an alternative embodiment.

30

Figure 7 is a profile cut-away view of an alternative embodiment of a stylus.

Figure 8 is a profile cut-away view of an alternative embodiment of a stylus.

Figure 9 is a close-up view of the drive coils of figure 9.

Figure 10 is a profile cut-away view of an alternative embodiment of a stylus.

5 Figure 11 is a cross-sectional profile view of another embodiment of a passive stylus.

Figure 12 is a cross-sectional profile view of the passive stylus of figure 11.

10 Figure 13 is a close-up cross-sectional view of the passive stylus of figure 11, with the stylus actuated to write on a display.

Figure 14 is a block circuit diagram that can be used to determine the degree of pressure being applied by a stylus tip on a writing surface.

15 Figure 15 is a circuit diagram of a transmitter utilized in an active stylus that is performing pressure sensing described in figure 14.

**Detailed Description:**

20 Reference will now be made to the drawings in which the various elements of the present invention will be given numerical designations and in which the invention will be discussed so as to enable one skilled in the art to make and use the invention. It is to be understood that the following description is only exemplary of the principles of the present invention, and should not be viewed as narrowing the claims which follow.

30 The presently preferred embodiment of the invention is a plurality of magnetic sensors that are capable of determining a location and orientation of a passive stylus that generates a magnetic field without using a power source. In the presently preferred

embodiment, the plurality of magnetic sensors are directionally sensitive devices. For example, the magnetic sensors can be a magnetic field sensor such as one sold having part number KMZ51 from Philips Semiconductors. However, any similar magnetic sensor can be substituted and create the same results. It is noted that the magnetic field sensor KMZ51 is relatively inexpensive, and is thus desirable for the applications herein.

10 In the presently preferred embodiment, the magnetic field sensors are disposed in pairs, stacked one on top of the other or arranged side-by-side, and separated by a non-conductive material such as PC board when they are stacked. Each pair of magnetic field sensors provides a vector to the stylus. Thus, two pairs of magnetic field sensors are sufficient to provide two vectors, and thus determine the location of the stylus in two dimensions.

20 In an alternative embodiment, a third magnetic field sensor is added to each pair, thus making two groups of three magnetic field sensors each. The third magnetic field sensor provides up-down sensitivity to give the configuration three-dimensional sensitivity.

25 It is noted that in the preferred embodiment, three magnetic field sensor sets will be arranged so as to have a straight line between them. For example, figure 1 shows a first magnetic sensor set 10, and a second magnetic sensor set 12, each set comprised of three magnetic field sensors 8. The directional sensitivity of each of the magnetic field sensors 8 is identified by the arrows 14. Note that the dot representing an arrow 14 in each set 10, 12 indicates



that sensitivity is directed out of the page. The approximate area of sensitivity is identified by dotted line 16.

Unfortunately, a stylus cannot be detected when  
5 it is disposed along the straight line 18 that lies directly between the first and second magnetic sensor sets 10, 12. To be detectable, it is preferable in an alternative embodiment to include a third set 20 of magnetic field sensors. This third set 20 makes  
10 detection of a stylus in three dimensions much simpler, and also eliminates the "blind spot" represented by line 18.

It is noted that in the alternative embodiment of three sets 10, 12, 20 of three magnetic field sensors  
15 each, the sets are preferably arranged as three corners of a square or rectangle. This area is represented by area 16.

It is important to recognize that the area of sensitivity can be varied according to the desired  
20 placement of the magnetic field sensor sets. This means that the area of sensitivity is a relative area that is based upon the needs of the application. For example, if the application is for a cursor control input device, then the area of sensitivity 22 could be  
25 as shown in figure 2A relative to three magnetic field sensor sets 24, or as in figures 2B or 2C. What is important to realize is that the area of sensitivity is very approximate, and will extend beyond the sharply defined lines of the figures. However, it is  
30 the practical realization that some arbitrarily defined area must be selected to give a user a feel for the area to operate in to write, draw, or cause

cursor movement in a defined area on a computer screen when that is the application of a stylus and sensors.

Figure 3 illustrates that the presently preferred stylus 30 is a generally pen-like object, having a permanent magnet 32 disposed near the tip 34 thereof. The stylus 30 preferably has a magnetic field whose strength is approximately equal to that of the earth's magnetic field.

In order to understand operation of the stylus 30, it must be considered in context with an understanding of the operation of the magnetic field sensors. Each magnetic field sensor of the preferred embodiment includes a polarizing coil. The polarizing coil allows a user to swap the direction in which a magnetic field sensor is sensitive. This feature enables a user to cancel out offsets, drift, etc. Generally, a user will only swap directions in order to occasionally "zero-out" the magnetic field sensor, but will generally not perform this operation before every measurement. The magnetic field sensors generally have good bandwidth, from about 1 volt DC to about 1 MHz.

As shown in figure 4, the magnetic field sensor is essentially a bridge 40, which also includes a nulling coil 42 and a flipping coil 44. In order to get a good dynamic range, it is best to avoid flipping before each measurement because as the magnetic field grows higher and higher, it starts saturating the magnetic field sensor. At that point, the magnetic field sensor begins to lose linearity.

Accordingly, the preferred magnetic field sensor includes the nulling coil 42. The output of a differential amplifier 46 is fed back into the nulling



coil 42. This allows obtaining a "zero" magnetic field on the magnetic field sensor, to thereby increase gain immensely while maintaining linearity.

It is important to realize that if the sensor system is to be accurate, the sensor system should not try to maintain a linear circuit. Instead, the user should select a null point, and then feed a linear DAC into it to maintain a null point. That provides the sensor system with a tremendous dynamic range. By using the nulling coil 42, it is possible to maintain linearity and better range.

It is also noted that the range of the magnetic field sensor is a function of several factors. An analog-to-digital (A/D) converter used in the presently preferred embodiment is 14 bits. This A/D convertor is sufficient to obtain an area of sensitivity that is approximately 8.5 by 11 inches, or a regular sheet of paper. This area of sensitivity is obtained when the sets of magnetic fields sensors are separated by approximately 4 or 5 inches. Using a 16 bit A/D converter would obtain an even greater range, and thus provide a larger area of sensitivity.

Assume that a sensor system is operated in the configuration as shown in figure 1, with three sets of three magnetic field sensors. When the sensor system is first turned on, the system will be assumed to be stationary and coupled to a desktop computer or other stationary device. The first action is to calibrate the sensor system so that it can determine its position relative to the earth's magnetic field. This information is preferably stored in a driver, RAM or other memory device. This information is used for sensitivity and correction



12

factors. Each magnetic field sensor set 10, 12, 20 provides a vector to a stylus that is disposed within the identified area of sensitivity 16. It is important to determine an absolute vector, then  
5 subtract out a calibration vector.

If all of the magnetic field sensor sets 10, 12, 20 give vectors that are parallel to each other, then it is assumed that there is no magnet within the area of sensitivity 16. Because the earth's magnetic field  
10 is also known, that is also subtracted out to thereby obtain a null space within the sensor system's field of sensitivity.

When the stylus is introduced into the null space (field of sensitivity), the threshold for the presence  
15 of the stylus is simply a determination that the vectors are no longer parallel. By subtracting out the magnetic field of the permanent magnet disposed within the stylus from the earth's relative magnetic field, the user obtains two vectors that point to the  
20 stylus. By triangulation, the location of the stylus is then determined.

Figure 5 is a schematic diagram of the presently preferred sensor system. As shown, a MUX 50 goes to all the magnetic field sensors 8 of the three magnetic  
25 field sensor sets 10, 12, 20. The signal from the MUX 50 goes to an A/D converter 52, which is then passed to a CPU 54. The presently preferred embodiment utilizes an A/D converter card disposed in a slot of a personal computer. The input to the A/D converter 52  
30 is accessed by a program executing on the personal computer to process a triangulation formula to thereby provide stylus position determination. A good example

of an A/D converter with adequate properties is an 8051 processor.

Some details on triangulation methods are useful to an understanding of implementing the present invention. Triangulation is usually done in one of two ways, neither of which is adequate for the present invention. The first method will not work because when either an x or y sensor has a value close to zero, it becomes for difficult to determine accurate coordinates. Furthermore, if the user is inclining the stylus, incorrect coordinates are again given.

The second method requires an alternating signal from the source of a fixed frequency and uses two sensors at a fixed distance from each other. This method is not useful for tracking the stylus of the present invention because the magnetic sensors look at non-alternating magnetic fields and frequency information is not available.

Thus, the present invention looks to the circular-triangulation method. This method uses a knowledge of how magnetic fields drop off in distance. As a magnetic source moves away from it's sensor, the sensor records a value that is proportional to the inverse cube of the distance between the source and sensor. This information enables a hypothetical circle to be drawn around the sensor at a radius that is calculated from the sensor value and the inverse-cube formula. This circle projects all the possible points the stylus can be on.

A second sensor at a fixed distance away projects another circle of a different radius. The circles intersect in at most two points, with one of the points being behind the sensors in a non-drawing area,

which means that this point can be eliminated as a solution. The remaining point's coordinates are thus calculated by solving for the intersection of the two circles and using the positive solution as the  
5 coordinates of the stylus.

This method has the advantage of only requiring two x or two y sensors separated at a distance, as opposed to the four sensors required for the angle methods described above.

10 Advantageously, changes in the pen's angle with respect to the writing surface do not influence the calculation of the stylus' coordinates if two x and y sensors are used at each sensing location. A decrease in x from one set of sensors will be compensated for  
15 by an increase in the corresponding y from that set. The magnitude between the two sensors can be determined as the square root of  $(x^2 + y^2)$ . This eliminates angle disturbances because of low x and y values, and eliminates the effects of pen angle with  
20 respect to a writing surface.

This method also allows for increased distance because of the use of raw sensor magnitudes instead of angles calculated from these magnitudes. The same concept can be applied to electromagnetic fields,  
25 which lose energy in their fields by the inverse of the distance-squared, as opposed to inverse of distance-cubed for magnetic dipoles. Spheres can be drawn from each antenna to the source and the solution of the source's coordinates is found by solving for  
30 the intersection of the spheres. By triangulating electromagnetic sources with this method, dependence on the angle that the object is facing with respect to



the antennas of the magnetic sensors can be eliminated.

The stylus 30 used with the presently preferred and alternative embodiments has been described as a passive device with a permanent magnet 32 disposed  
5 therein. However, the present invention also teaches alternative designs for the stylus that include modifications to the passive configuration, and the addition of active elements that enable the user to do  
10 more than just determine the location thereof.

For example, to enhance the passive stylus, it can be advantageous to alter the strength of the magnetic field generated by the stylus. If this change in strength can be detected, the stylus is able  
15 to provide more input information to a receiving device. An embodiment that provides a changing magnetic field relies on applying pressure to a stylus tip.

In figure 6, the increased pressure pushes a stylus tip 60 inwards until the first permanent magnet 62 makes contacts with a second permanent magnet 64. The magnetic field of the combined permanent magnets 62, 64 is larger than the individual magnets, and this increase in magnetic field strength is detectable.  
20 Releasing pressure on the stylus tip 60 enables a spring 66 to push the permanent magnets 62, 64 apart, returning the magnetic field strength to an initial state. This is all done without the use of a power source.  
25

30 In an alternative embodiment, it is possible to introduce active elements that go beyond the basic stylus design above. For example, figure 7 is an alternative embodiment of an active stylus 70. In

this embodiment, the inner detail of the stylus 70 is illustrated to show that a permanent magnet 72 is oriented in a first orientation when at rest. Shown here, the south pole of the magnet is toward the stylus tip. When pressure is applied to the stylus tip 74, a rod 76 pushes on the permanent magnet 72, causing it to rotate. The rotation reverses the polarity of the permanent magnet 72, causing the south pole to be on the opposite side, away from the stylus tip 74. Thus, the stylus again provides a signal to an input device. The signal could be a digital 1 changing to a digital 0, or vice versa. The spring 78 pushes the rod 76 back towards the stylus tip 74 and thus causes the permanent magnet to rotate back to an original orientation when pressure is removed from the stylus tip.

Generally, a stylus does not need to provide "Z" to an input device. However, "Z" orientation is useful when using an electronic paintbrush because it provides an infinite range of pressure values.

The next alternative embodiment of an active stylus is shown in figure 8. The stylus 80 is shown having a coil configuration 82 near the tip 84 of the stylus. The coil configuration 82 comprises three coils 86, 88, 90 disposed about a sphere 92 as shown in close-up in figure 9. The coils 86, 88, 90 are drive coils having three different frequencies, from 250 KHz to 1 MHz. Each of the magnetic field sensor sets would be tuned to be sensitive to a different drive coil. In this way, the sensor system would not only be able to track the location of each drive coil in three dimensions, but it would also enable the detection of rotation. The only drawback to this



embodiment is that the drive coils would require power to drive them at the required frequencies. However, the tradeoff is obtaining not only XYZ position, but pitch, roll, and yaw. Thus, the sensor system would have six (6) degrees of freedom. It is noted that it would be possible to transmit the signals from each coil 86, 88, 90 to another device, such as a personal digital assistant (PDA), because each coil functions as an antenna of its own signal, thus providing a wireless connection.

Accordingly, the present invention enables the use of static magnetic fields instead of dynamic fields. This fact provides a way to use permanent magnets that do not require power when using the basic features of the invention, and only requires power when trying to do provide more features to the user.

Figure 10 is provided as an illustration of another means for increasing magnetic field strength. The stylus tip 100 is coupled to a permanent magnet 102 and to a cylindrical coil 104 (shown in cross-section). When the spring 106 is compressed by the tip 100 until making contact with another cylindrical coil 108, the magnetic field strength is increased.

Figure 11 is a cross-sectional profile view of an alternative embodiment of a passive stylus 110 in an exploded view. This passive stylus 110 provides "start" and "stop" signals to the magnetic sensors through a novel use of a tilting magnet. The components of the passive stylus 110 are a plastic housing 112 or other material that will not interfere with magnetic fields. The housing 112 has a plastic or ferrous housing cap 114 that can be removed in order to replace an ink cartridge 116. The ink



cartridge 116 includes an interference fit threaded ferrous component 118 with the housing 112. The threaded ferrous component 118 is threaded in order to couple the plastic housing cap 114 to the plastic housing 112. A spring 120 is disposed between the interference fit threaded ferrous component 118 and the inside of the plastic housing cap 114. Above the interference fit 118 are disposed circular ceramic magnets 122 that have a hole through the middle for the ink cartridge 116 to pass through. The number of ceramic magnets 122 depends upon the sensitivity of the magnet sensors that are being used to detect the location of the ceramic magnets. More or stronger magnets will improve detection of the passive stylus 110.

On the top of the ink cartridge 116 is disposed a plastic actuator 124. This plastic actuator is used to more uniformly push on the rare earth magnet 126. Whereas the top of the ink cartridge might be dented or otherwise made irregular, the plastic actuator 124 presents a consistent interface to the magnet 126. Between the plastic actuator 124 and the rare earth magnet 126 are disposed a ceramic trigger magnet 128, and a ferrous washer 130 with pitched ID. The last two components are a ferrous cylinder 132 that extends along most of the length of the plastic housing 112, and a plastic housing cap 134 that is screwed into the plastic housing 112.

Figure 12 is a cross-sectional profile view of the passive stylus 110 shown in figure 11, but put together in an operable mode.

Operation of the passive stylus 110 is novel in its system for enabling the magnetic sensors to

determine when a user wants to begin writing on a display, and to stop writing. A user will begin to write with the passive stylus 110. After gentle and nominal pressure is applied, as when a person presses  
5 down on paper to write with ink, the passive stylus 110 actuates the "start" signal, indicating that an associated display device is to begin "inking" or writing on a display.

This "start" signal is generated by the pressure  
10 on the ink cartridge 116. This pressure causes the ink cartridge 116 to move approximately 1/16 to 1/8 of an inch upwards into the plastic housing 112. The ink cartridge 116 is coupled to the plastic actuator 124, which is turn moves through a whole in the ceramic  
15 trigger magnet 128, and then partially into the pitched ID of the ferrous washer 130. Movement of the ink cartridge 116 is stopped because of the plastic actuator 124 that cannot move past the ceramic trigger magnet 128 when a lower shelf 136 meets the bottom 138  
20 of the ceramic trigger magnet.

Figure 13 is provided as a close-up view of how the above-described process will appear when the user is writing. The figure shows the plastic housing 112, the rare earth magnet 126 that is now in an upright  
25 position, the ferrous washer 130 with the pitched ID, the ceramic trigger magnet 128, and the plastic actuator 124. A tip 140 of the plastic actuator 126 is pushing up on a bottom surface of the magnet 126. The magnet 126 is now resting on a small lip 142 of  
30 the ferrous washer 130.

It may not be obvious why tipping the rare earth magnet 126 from an inclined position to an upright position will provide a "start" signal. However, the

magnetic sensors that are tracking the position of the passive stylus 110 are also detecting the rare earth magnet 126. When the rare earth magnet 126 is at rest in the inclined position shown in figures 11 and 12, the magnet 126 is actually being held in place by magnetic attraction to the ferrous washer 130. The force required to break the rare earth magnet 126 free is relatively small, approximately 80 to 100 grams of force. However, when the rare earth magnet 126 breaks free, it accelerates rapidly and moves to the upright position to which it is also magnetically attracted on the lip 142 of the ferrous washer 130. Even though the distance moved by the rare earth magnet 126 is very small, it is very detectable. Fortunately, the movement is also very rapid, which is the key to distinguishing this movement from ordinary movement of the passive stylus 110 when writing. This movement is so fast that it will not be accidentally caused through normal use of the stylus.

Likewise, the release of pressure off the ink cartridge 116 will enable the stronger attraction of the rare earth magnet 126 to be in the inclined position to occur. The amount of force is approximately 45 to 50 grams, but can be varied as desired, as can the actuation force. The rare earth magnet is trying to be in the inclined position because the lip 142 is small as compared to the broader surface of the pitched ID of the ferrous washer 130.

The movement of the ink cartridge 116 that is necessary to send the start and stop signals is barely detectable, enabling the passive stylus 110 to function well as a normal inking pen. The movement of



the rare earth magnet as it snaps into an actuated upright position, and then snaps back to the released inclined position does not interfere with use of the stylus. Furthermore, various methods of dampening any outward indication of this motion is possible by  
5 modifying the plastic housing 112.

Another aspect of the present invention is to provide pressure sensing utilizing an active stylus. Varying degrees of pressure applied to the stylus tip are difficult to detect with the magnetic sensors. Accordingly, a resistive rubber is used to detect  
10 pressure. The rubber changes resistance for small changes in compression. The force of the stylus' ink cartridge on a writing surface is used to compress the rubber against the case of the stylus. This change in  
15 resistance is used to change the frequency of an RC oscillator. This information is then sent to a frequency modulated transmitter. The data is transmitted to a receiver on a controller board. A  
20 microcontroller on the controller board determines the frequency of the signal, or the change from a given frequency, to thereby determine the degree of pressure that is being applied to the stylus tip on a writing surface. Ultimately, the pressure data can be  
25 displayed in two different ways. Either the width of line being drawn can be varied, or an inking gray scale is displayed on a computer display.

The resistive rubber acting as a pressure transducer for the present invention is operating in the circuit described in figure 14. Figure 14 shows  
30 the resistive rubber 150 coupled to an RC circuit 152. For example, a 555 chip can receive inputs from the resistive rubber 150. Output from the RC circuit 152

is sent to an RF modulator 154 for transmission via antenna 156. Output from the RF modulator 154 is utilized to determine the degree of compression of the resistive rubber 150, and thus the degree to which  
5 pressure is being applied. A conversion table can be used to relate the amount of pressure being applied to a value for the width of a line being drawn, or the shade of gray that should be applied.

A resistive rubber that can be used in the  
10 present invention is sold under the brand name of ZOFLEX ZF40(TM). Figure 15 is provided as an example of a circuit that can be utilized to transmit the pressure data from the stylus to the controller board. This is a sample only, and should not be  
15 considered limiting. However, it is noted that this type of transmitter can be disposed within the space limitations of a stylus.

It is noted that the present invention has many applications, especially with mobile appliances such  
20 as cell phones, digital phones, PDA's and other similar electronic appliances that need simple yet efficient ways of inputting data to an electronic device.

Another aspect of the invention is the ability to  
25 detect very small and precise positioning of the passive stylus. This enables the passive stylus to be used in a very small area that is defined as a keyboard. The keys of the keyboard are actuated by the small tip of the passive stylus. For example,  
30 consider a small keyboard that is coupled to a mobile telephone. The keyboard contains the magnetic sensors of the present invention, and can determine what key is being touched by a tip of the passive stylus. This



detection ability can enable rapid input of text to a mobile phone, for example, to send email messages.

By providing the keyboard with its own memory, the keyboard could also be provided with a small  
5 display screen, such as one line of text on an LCD display. The keyboard could then even be used when not attached to the mobile telephone, for example, to take notes during a call. Afterward when the keyboard is attached to the mobile telephone, the memory of the  
10 keyboard is uploaded or synchronized with the memory in the mobile telephone, so that a user can input data that has been stored by the keyboard. For example, a user can take notes on the keyboard while talking on the mobile telephone. After the conversation is over,  
15 the user attaches the keyboard to the mobile telephone, and uploads whatever data was typed into the keyboard memory into the memory of the mobile telephone. Typically, this action is performed in order to send the data in an email message from the  
20 mobile telephone.

However, the keyboard does not have to be used apart from the mobile telephone. The keyboard can be used when attached to the mobile telephone. The user may be able to take advantage of the larger display of  
25 the mobile telephone, or just continue to use the built-in LCD display of the keyboard. This may depend on the visibility of the LCD display when the keyboard is attached to the mobile telephone.

It is to be understood that the above-  
30 described arrangements are only illustrative of the application of the principles of the present invention. Numerous modifications and alternative arrangements may be devised by those skilled in the



art without departing from the spirit and scope of the present invention. The appended claims are intended to cover such modifications and arrangements.

**Claims**

What is claimed is:

1. A passive stylus system for providing input to an electronic appliance, wherein the passive stylus  
5 utilizes a permanent magnet to provide location information to a magnetic sensor system, said passive stylus comprising: a passive stylus including at least one permanent magnet;  
a magnetic sensor system for detecting a location  
10 of the at least one permanent magnet disposed within the passive stylus, wherein the magnetic sensor system further comprises a plurality of magnetic sensors that are capable of (1) detecting the at least one permanent magnet, (2) determining a location of the at  
15 least one permanent magnet relative to a reference point, and (3) transmitting the location of the at least one permanent magnet; and  
a display system, wherein the display system utilizes the location of the at least one permanent  
20 magnet to display data on the display system that represents movement of the passive stylus within a field of operation.
2. The passive stylus system as defined in claim 1  
25 wherein the magnetic sensor system further comprises at least two magnetic sensors that provide x and y coordinate information.
3. The passive stylus system as defined in claim 2  
30 wherein the system further comprises utilizing a circular triangulation formula for determining a location of the passive stylus, wherein data from the at least two magnetic sensors is utilized in the

circular triangulation formula to reduce inaccuracies in passive stylus position determination due to inclination or movement of the passive stylus.

- 5 4. The passive stylus system as defined in claim 3 wherein the passive stylus further comprises:
- a stylus body for housing components of the passive stylus;
  - an ink cartridge;
  - 10 an actuator disposed on a non-inking end of the ink cartridge;
  - at least one position magnet disposed adjacent to an inking end of the ink cartridge, having a hole through which the ink cartridge is disposed;
  - 15 a spring disposed around the ink cartridge, and between the at least one position magnet and a stylus tip;
  - a trigger magnet disposed above a non-inking end of the ink cartridge, and having a hole through which
  - 20 the actuator can pass;
  - a ferrous washer disposed above the trigger magnet, the ferrous washer having an outer shelf and an inner conical depression in a surface thereof;
  - a signaling magnet disposed at rest so as to be
  - 25 inclined, a bottom surface disposed at least partially at rest against the inner conical depression, wherein the ink cartridge will push the signaling magnet from an inclined position to an upright position so that the bottom surface of the signaling magnet is at least
  - 30 partially at rest against the outer shelf.
5. A method for providing input to an electronic



appliance utilizing a stylus system that incorporates a permanent magnet, said method comprising the steps of:

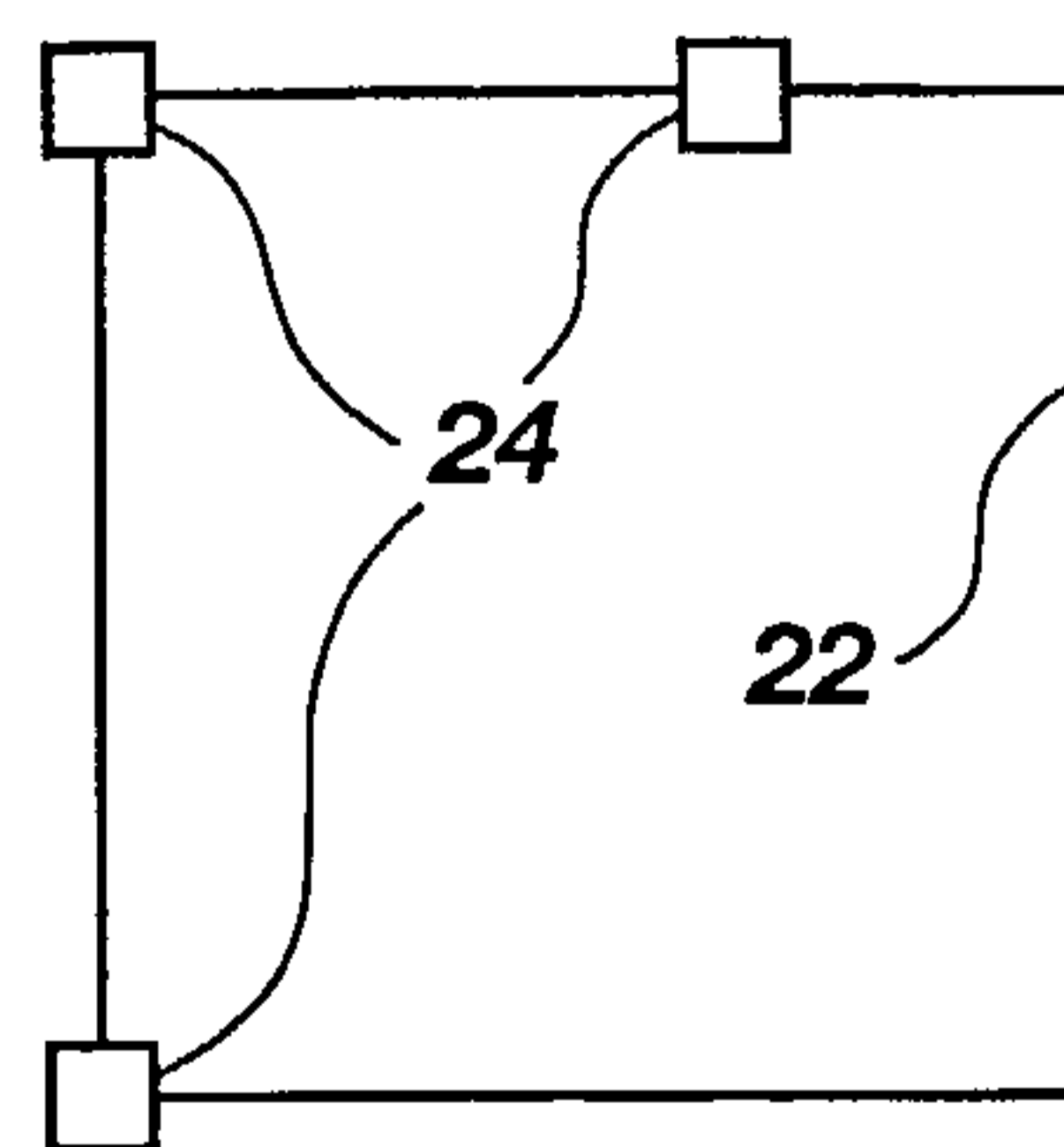
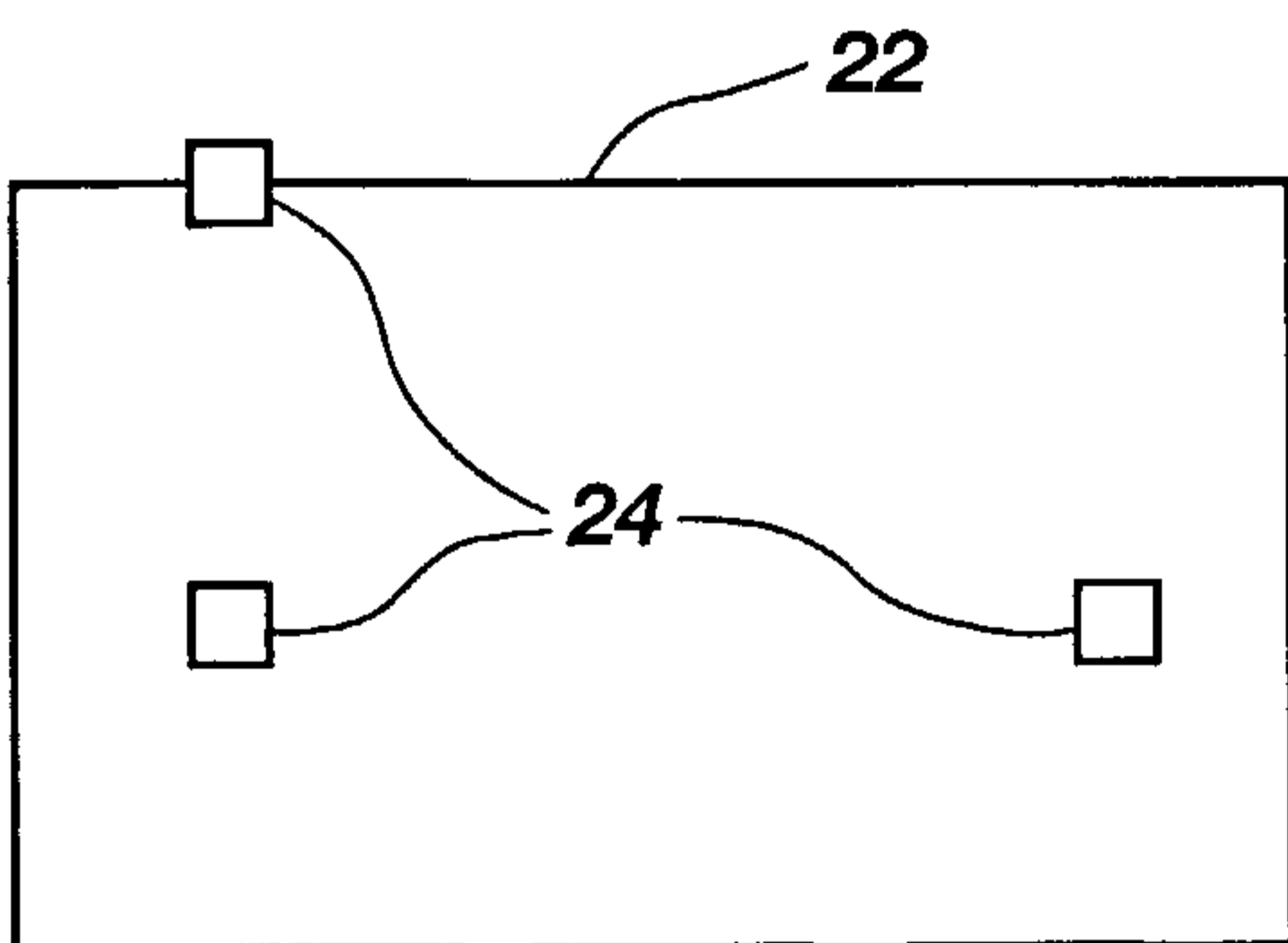
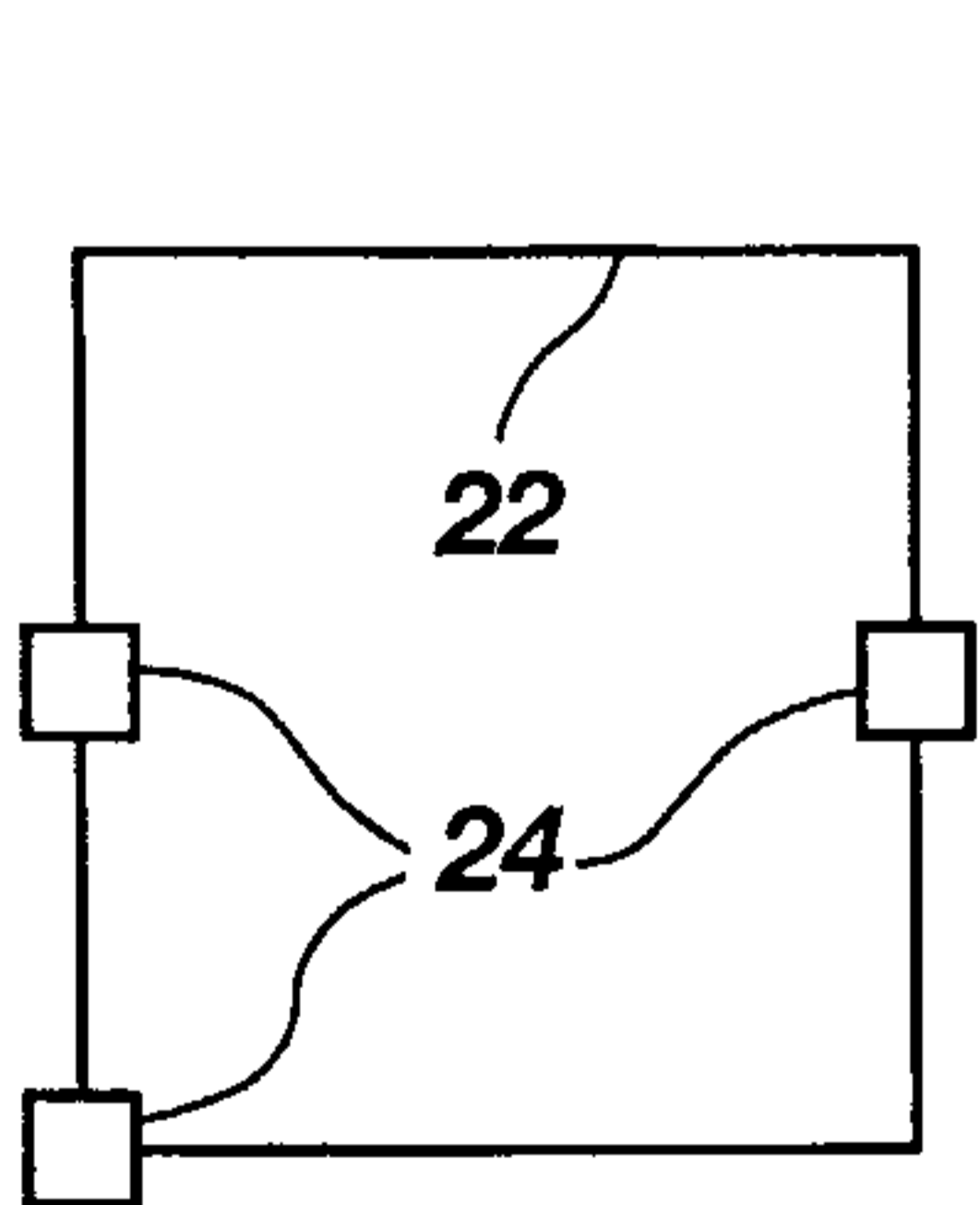
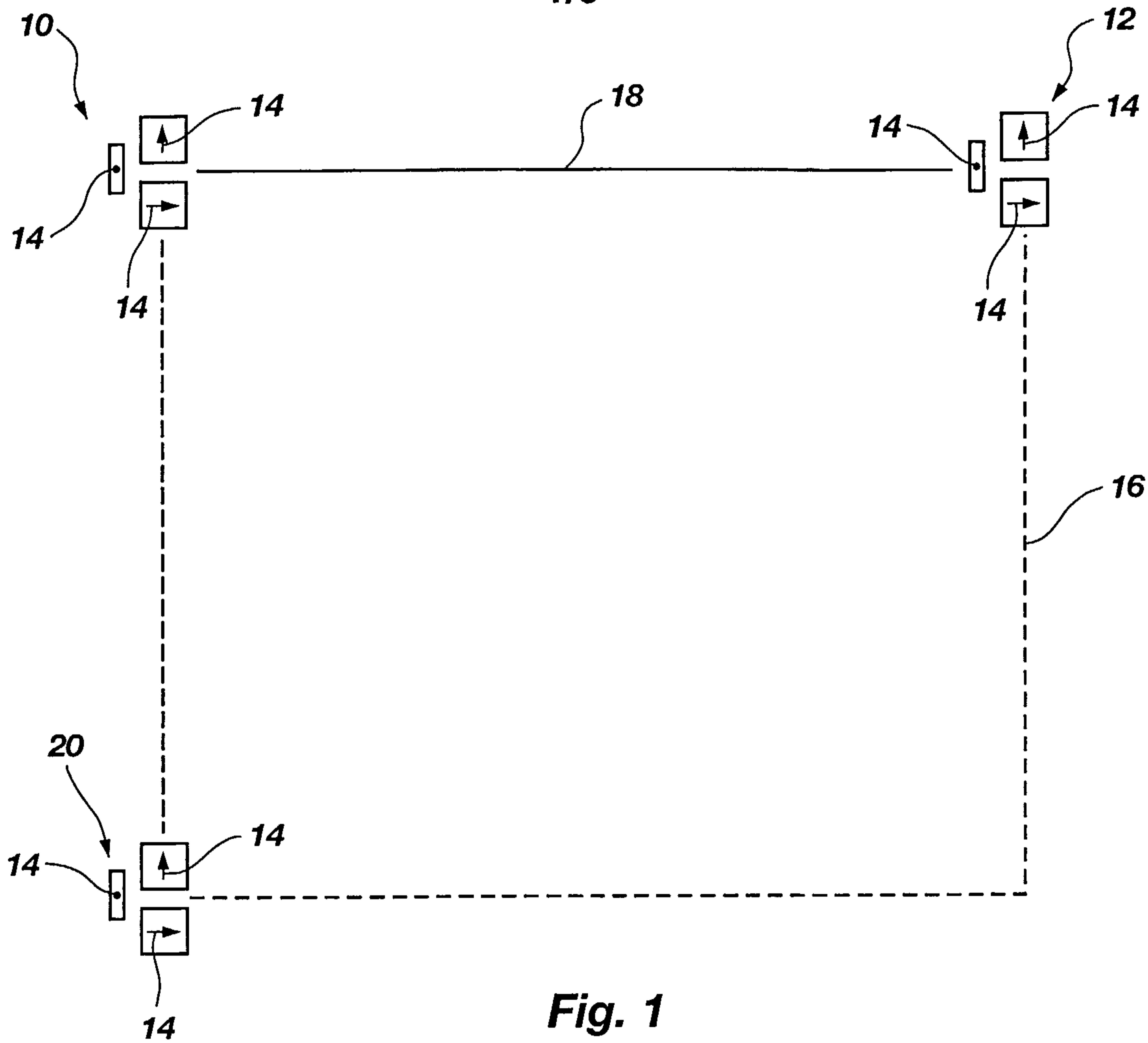
(1) providing a stylus body having a permanent  
5 magnet associated therewith, and a magnetic sensor system;

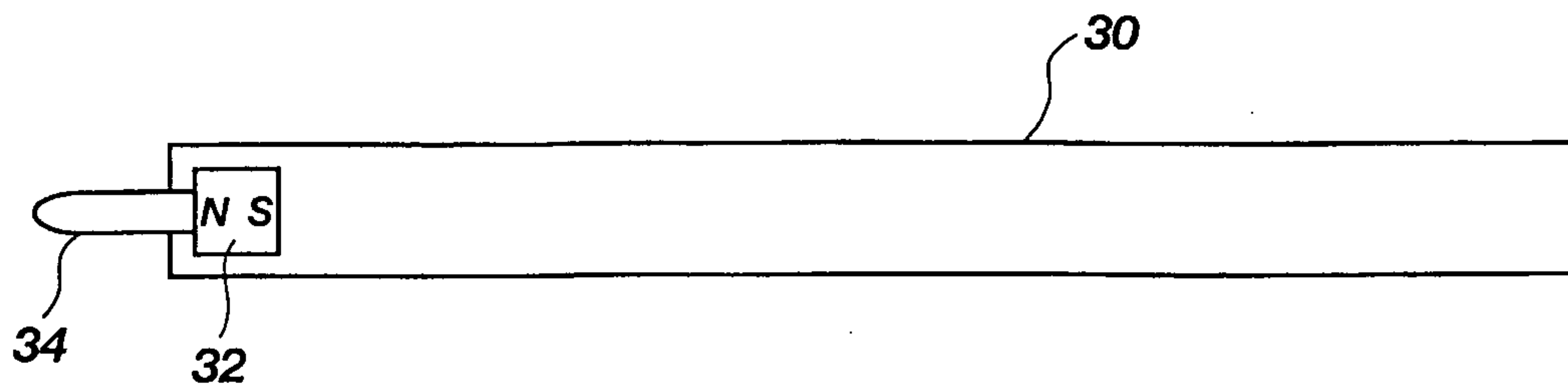
(2) detecting the permanent magnet utilizing the magnetic sensor system;

(3) determining a location of the permanent  
10 magnet relative to a reference point; and

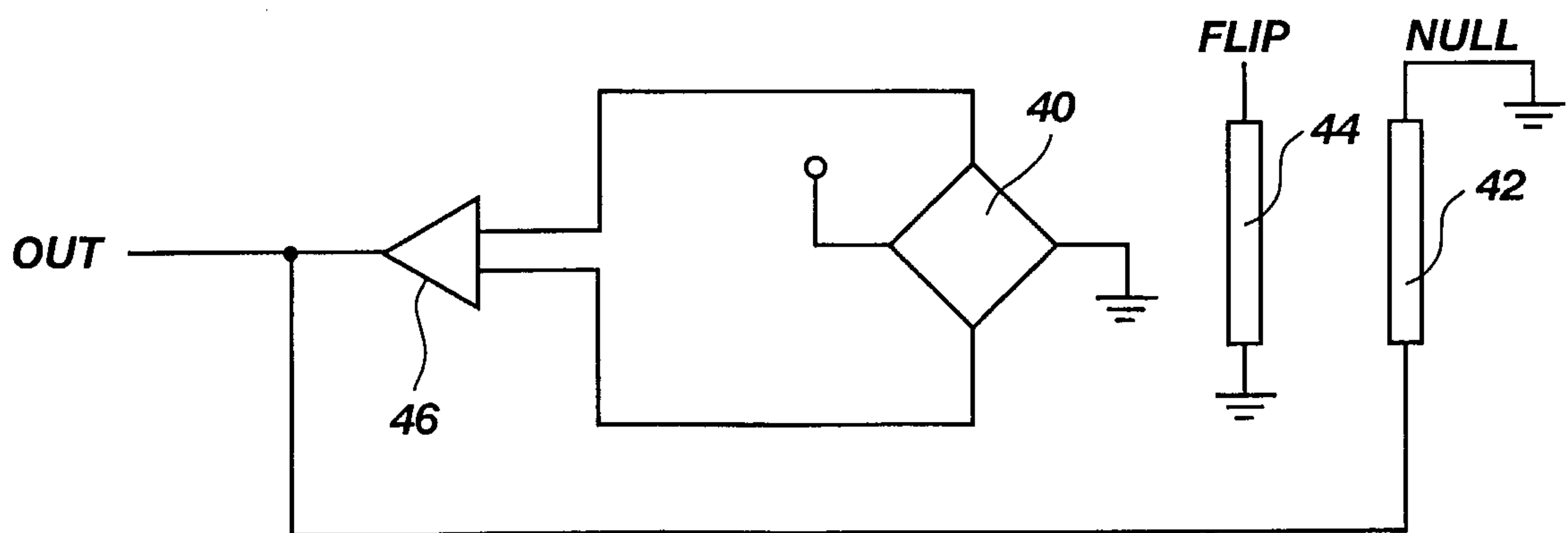
(4) transmitting the location of the permanent magnet in the stylus body.

1/9



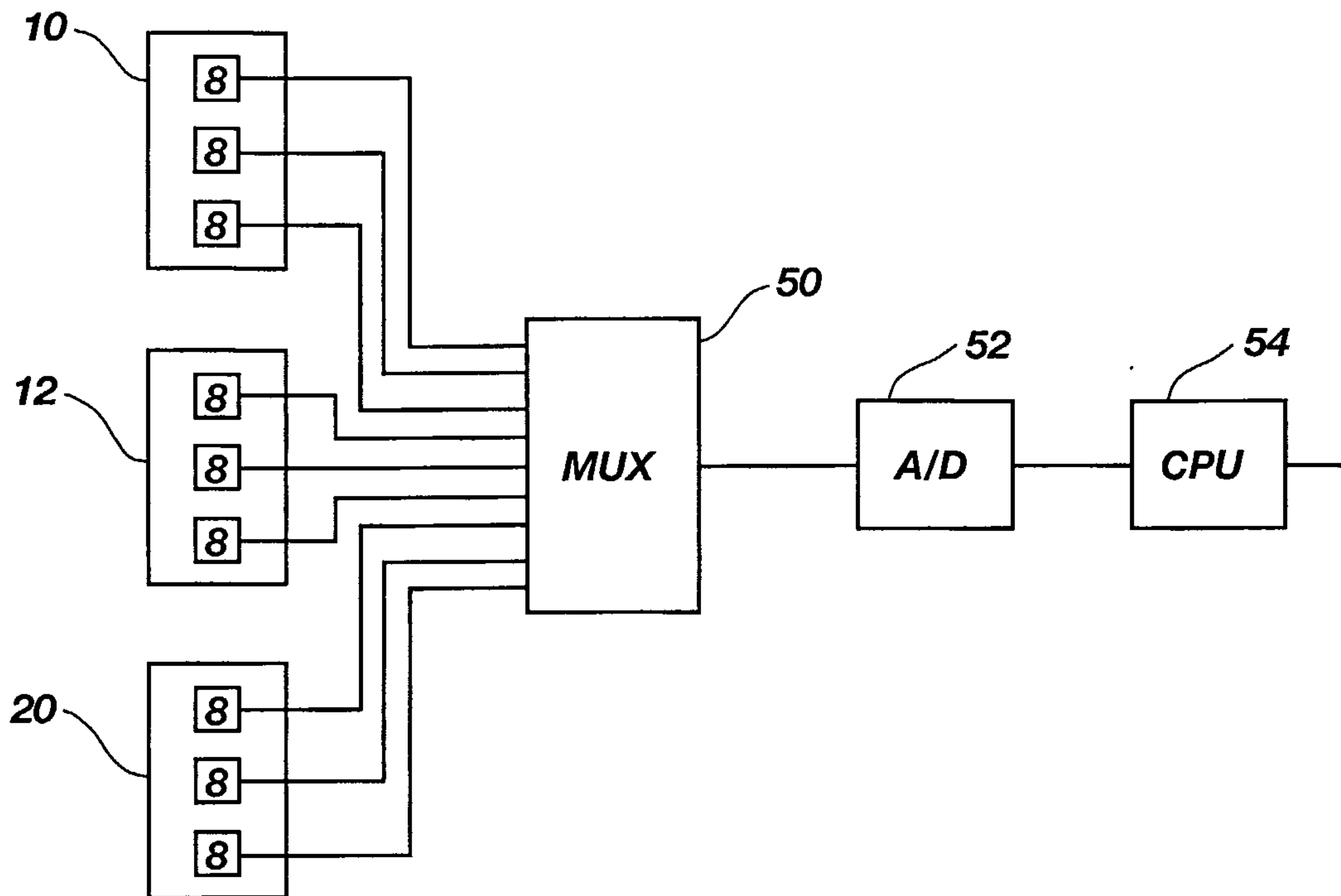


**Fig. 3**



**Fig. 4**





**Fig. 5**

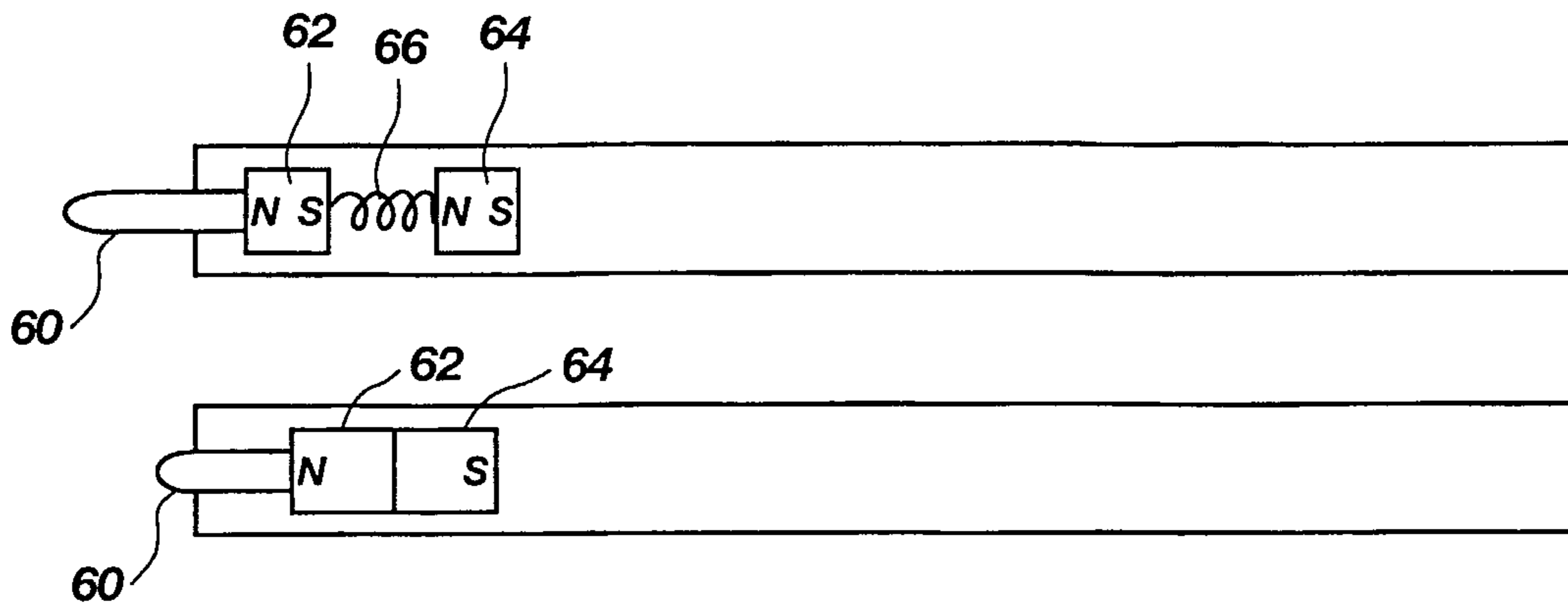


Fig. 6

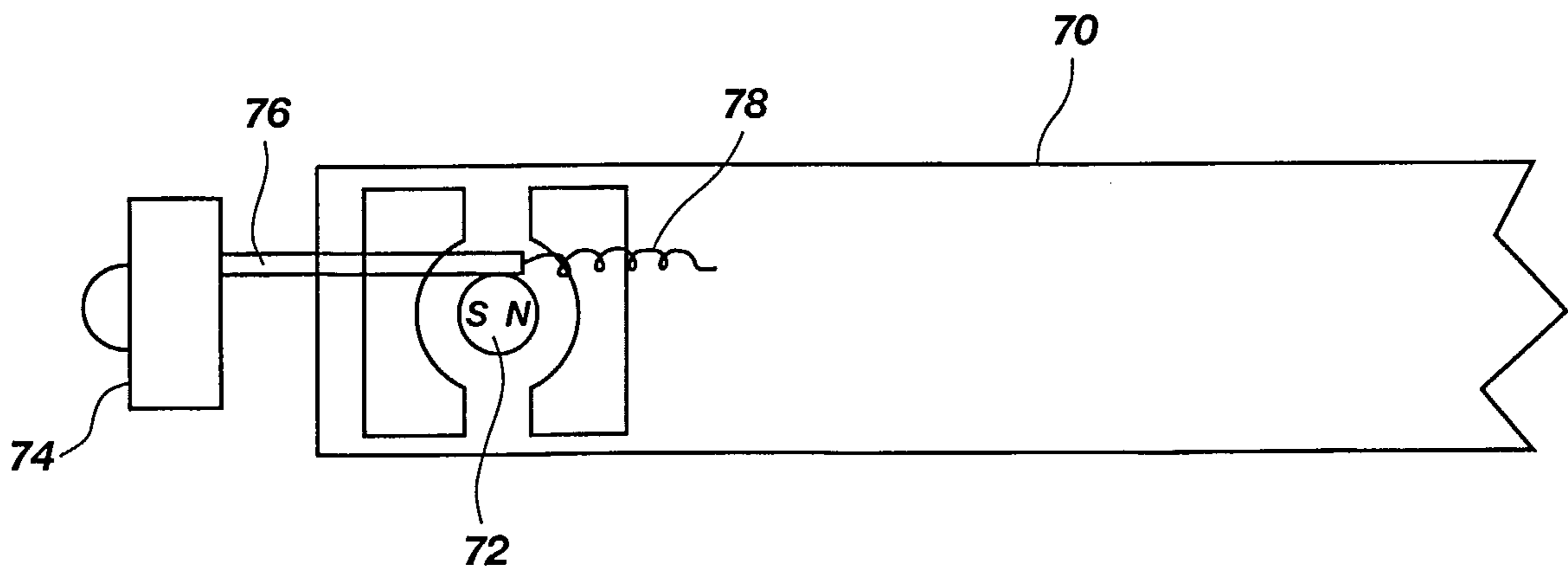


Fig. 7

5/9

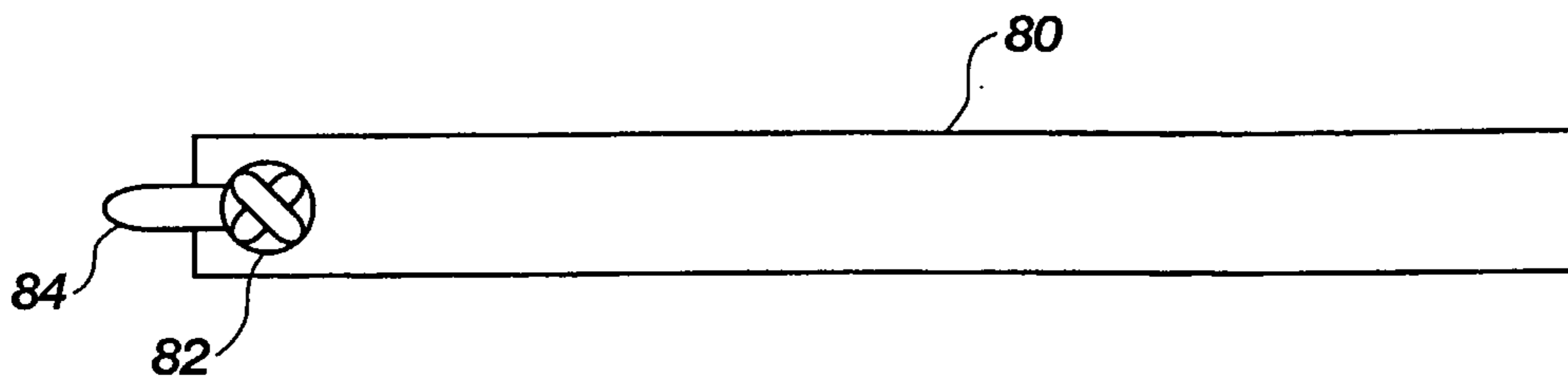


Fig. 8

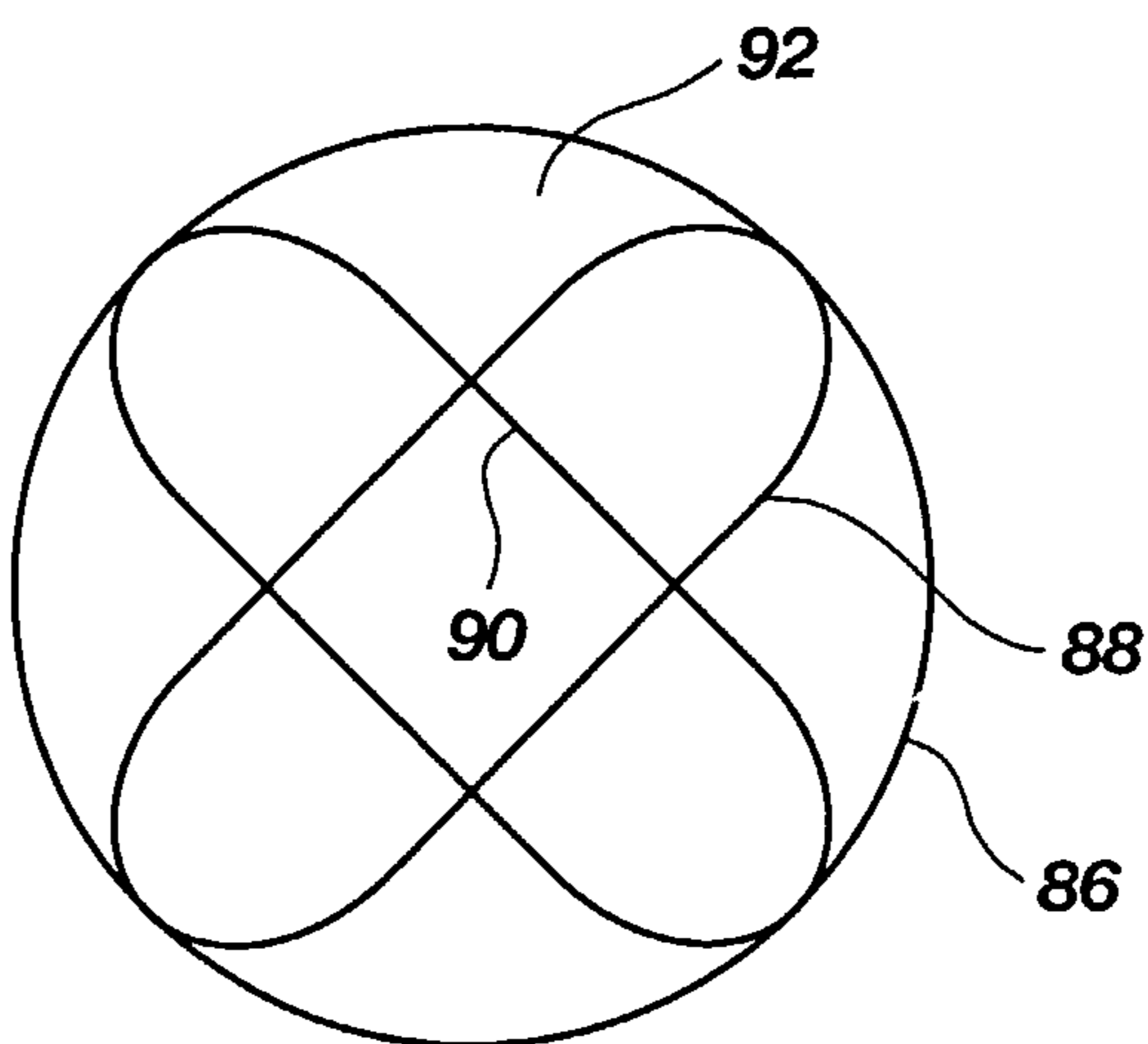


Fig. 9

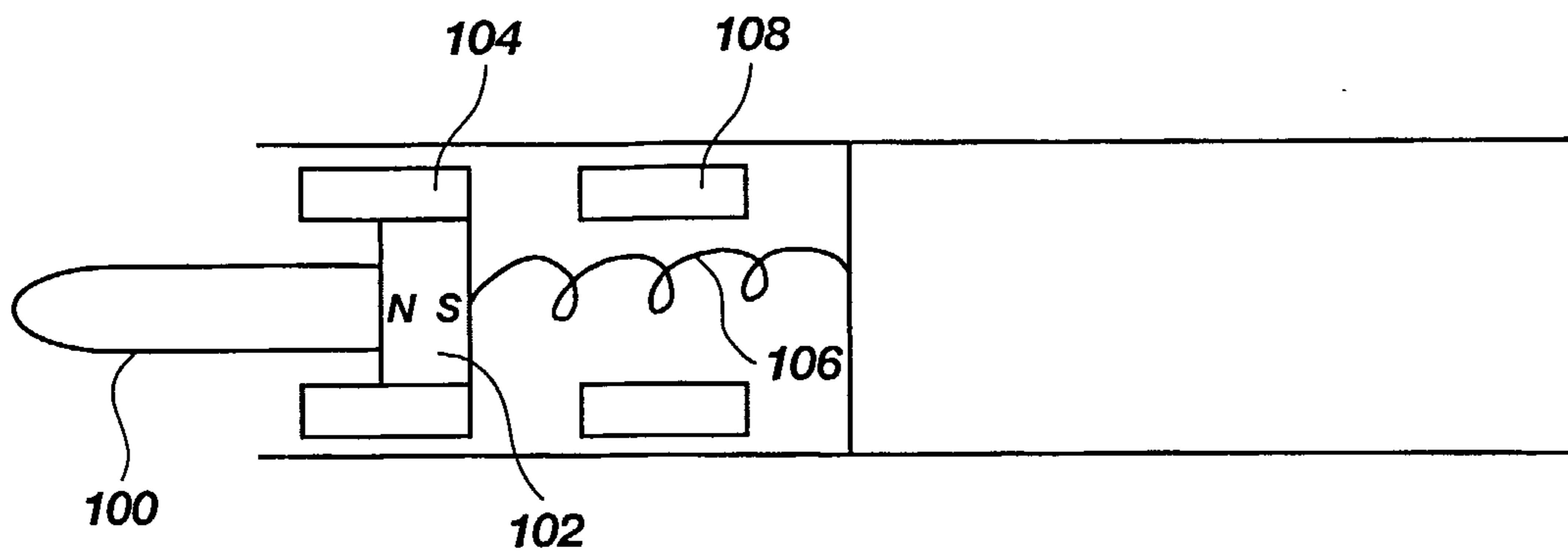
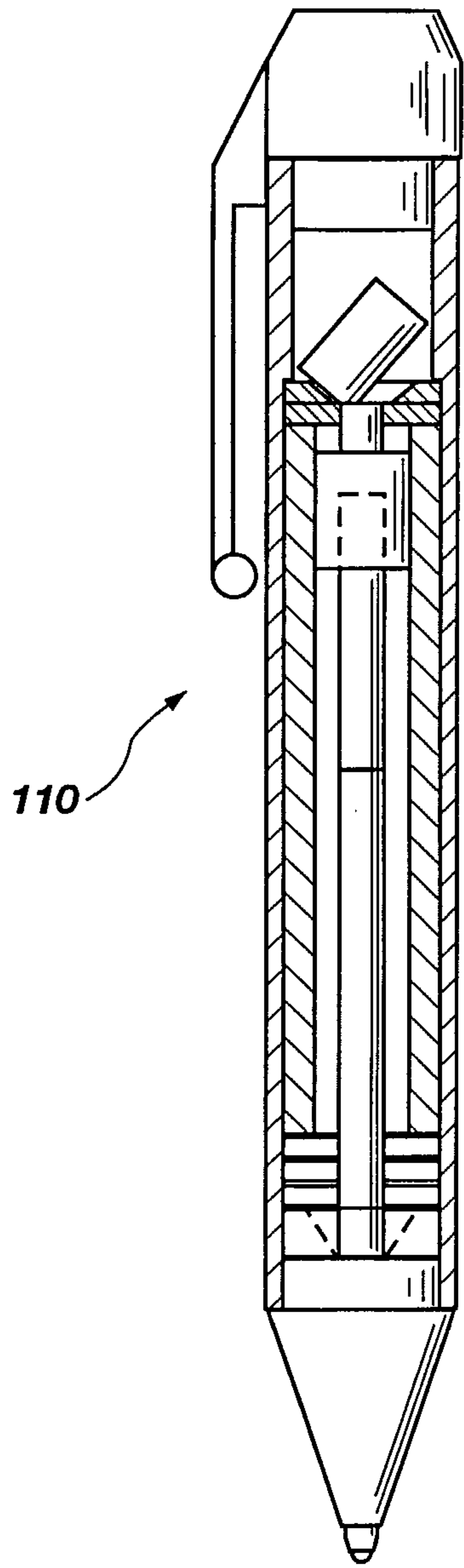
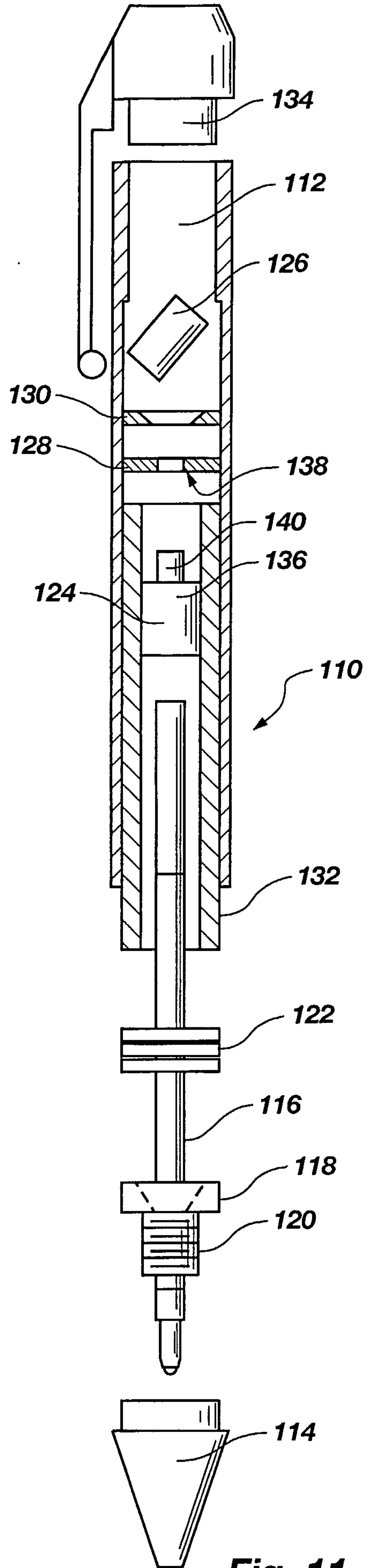


Fig. 10



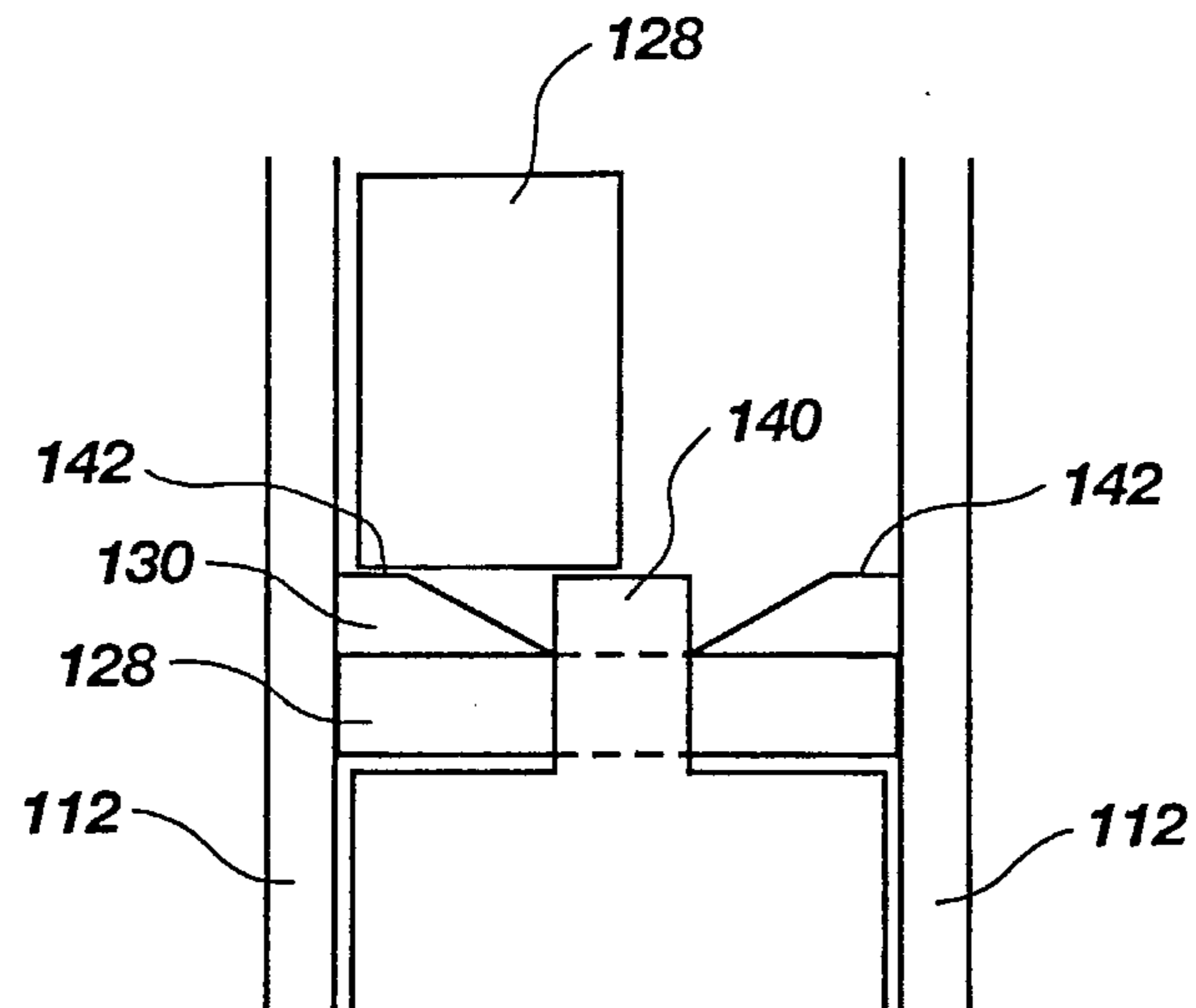


**Fig. 12**



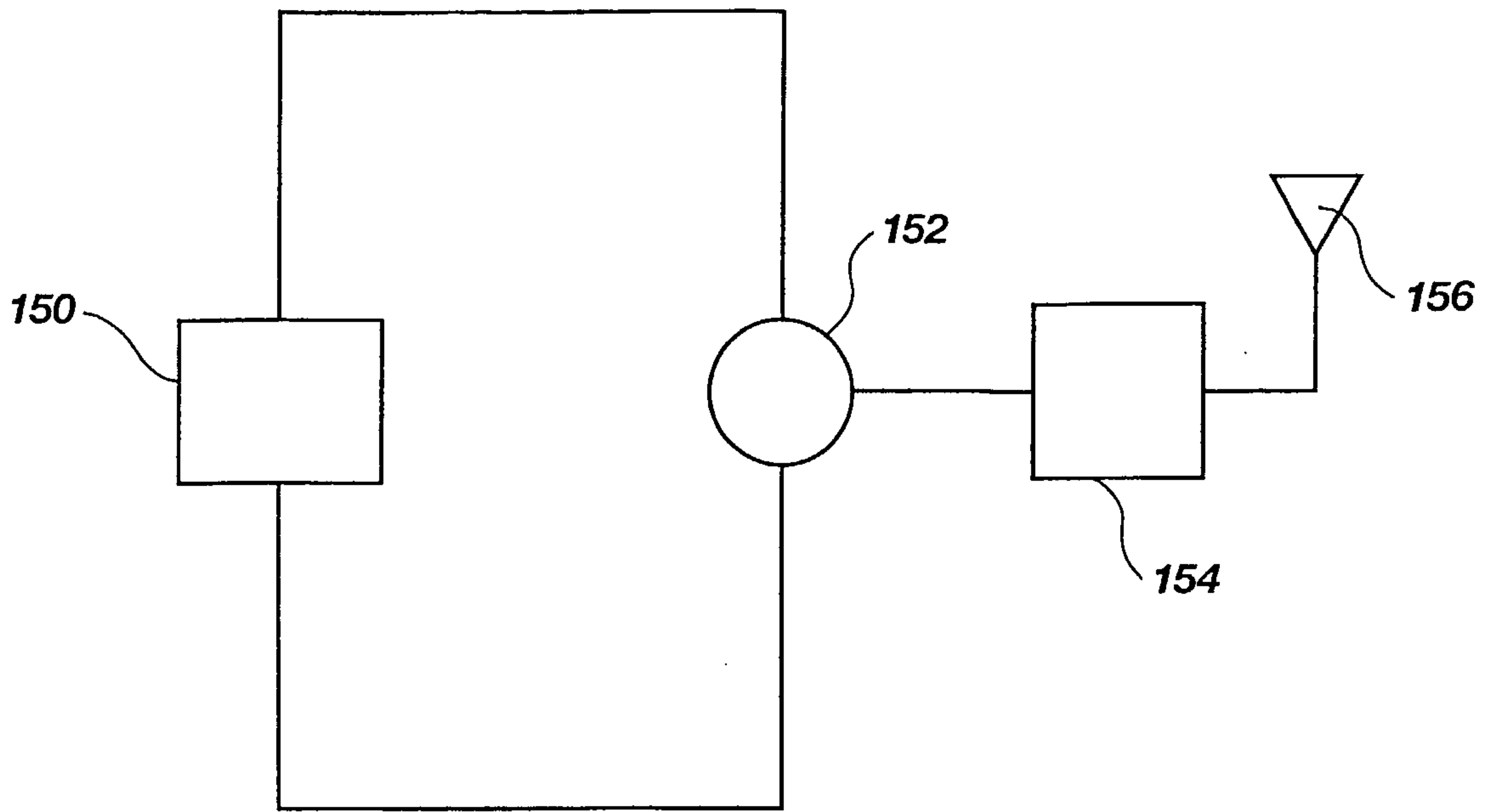
**Fig. 11**

7/9



**Fig. 13**

8/9



**Fig. 14**



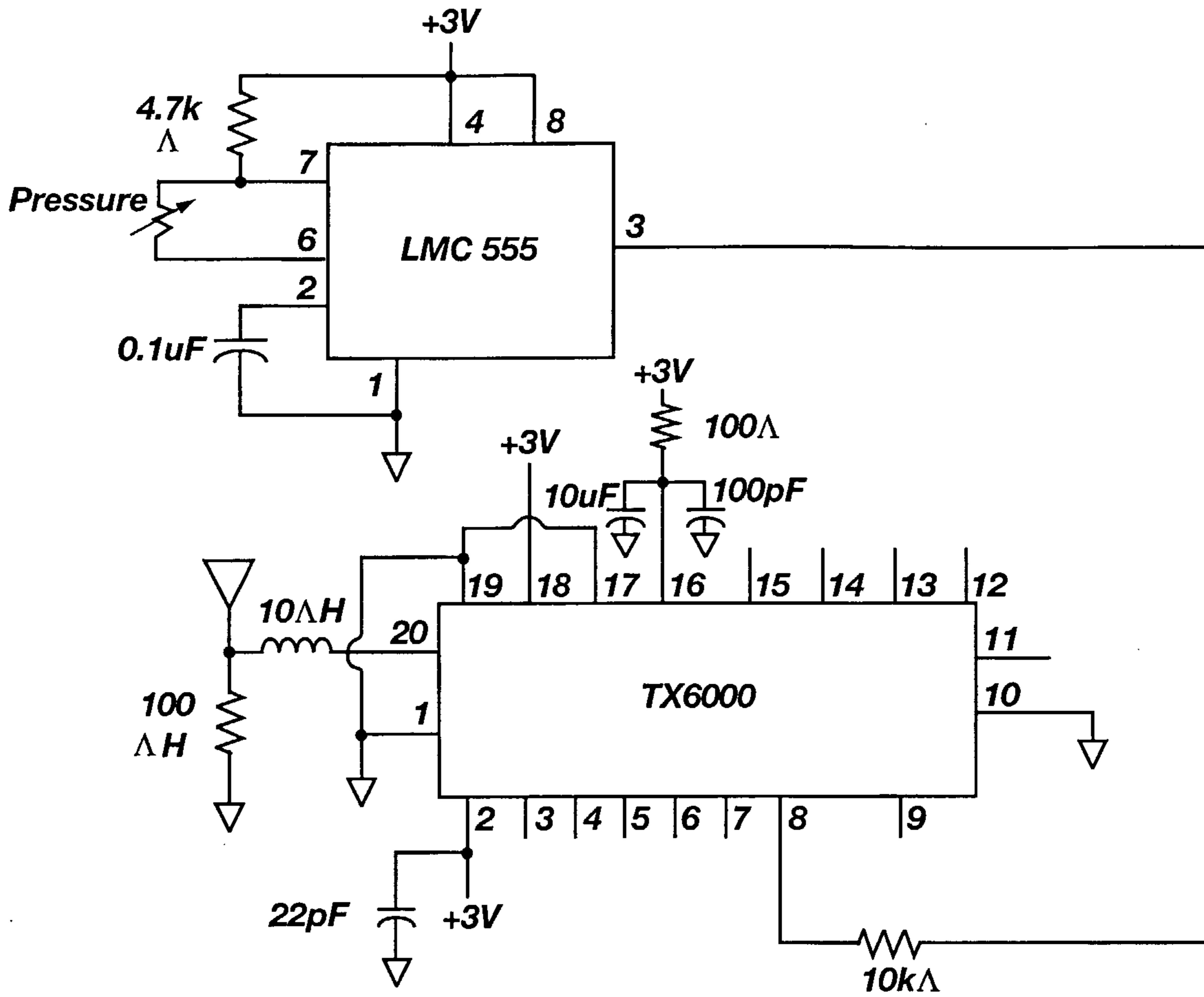


Fig. 15

