



US00D969308S

(12) **United States Design Patent**
Duval

(10) **Patent No.:** **US D969,308 S**

(45) **Date of Patent:** **** Nov. 8, 2022**

(54) **FLUID COLLECTION APPARATUS**

FOREIGN PATENT DOCUMENTS

(71) Applicant: **UR24TECHNOLOGY, INC.**, Newport Beach, CA (US)

CN 105287084 2/2016
CN 205234739 5/2016

(Continued)

(72) Inventor: **Landon Duval**, San Clemente, CA (US)

OTHER PUBLICATIONS

(73) Assignee: **UR24TECHNOLOGY, INC.**, Newport Beach, CA (US)

UR24 Technology, Inc [@Ur24T]. "See how our external catheter systems stack up to competitors in design, efficacy, comfort, and ease of use. <https://ur24technology.com/our-product>." Twitter.com, Published: [Jun. 16, 2021], Site Visited: [Jan. 7, 2022], URL: <<https://mobile.twitter.com/Ur24T/status/1405210639954497536>>. (Year: 2021).*

(**) Term: **15 Years**

(Continued)

(21) Appl. No.: **29/736,239**

(22) Filed: **May 28, 2020**

Primary Examiner — Jonathan J Han

(51) **LOC (13) Cl.** **24-04**

Assistant Examiner — Amanda J Berlinski

(52) **U.S. Cl.**

(74) *Attorney, Agent, or Firm* — Knobbe, Martens, Olson & Bear LLP

USPC **D24/122**

(58) **Field of Classification Search**

(57) **CLAIM**

USPC D24/107, 108, 110, 111, 112, 114, 121, D24/122, 123, 127, 128, 129, 162, 216, D24/224; D23/200, 302, 303, 309; 4/144.1–144.4; 285/21.2; 600/573, 582; 604/317, 329, 334, 349

The ornamental design for a fluid collection apparatus, as shown and described.

CPC A61F 5/441; A61F 5/4405; A61F 5/453; A61F 5/455

DESCRIPTION

See application file for complete search history.

FIG. 1 is a perspective view of a fluid collection apparatus configured in accordance with the present invention; FIG. 2 is a top view of the article of FIG. 1; FIG. 3 is a bottom view of the article of FIG. 1; FIG. 4 is a left side view of the article of FIG. 1; FIG. 5 is a right side view of the article of FIG. 1; FIG. 6 is a front view of the article of FIG. 1; and, FIG. 7 is a back view of the article of FIG. 1.

The broken lines in the drawings are included for the purpose of illustrating portions of the fluid collection apparatus that form no part of the claimed design. The fluid collection apparatus is shown with a symbolic break in its length. Any portions not shown between the break lines form no part of the claimed design.

(56) **References Cited**

U.S. PATENT DOCUMENTS

660,388 A	10/1900	Moberg et al.
1,742,080 A	12/1929	Jones
2,483,079 A	9/1949	Williams
2,571,357 A	10/1951	Charles
2,698,016 A	12/1954	Andrade et al.
2,739,595 A	3/1956	Coles
2,763,266 A	9/1956	Evans

(Continued)

1 Claim, 6 Drawing Sheets

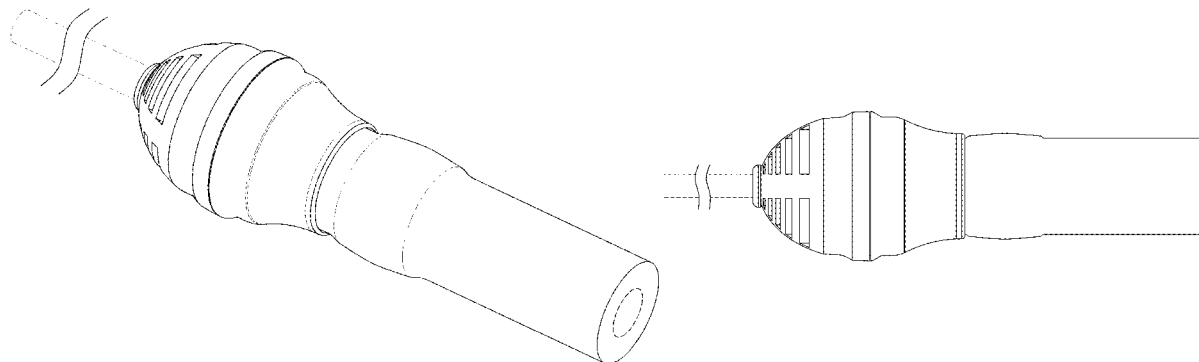

US D969,308 S

(56)

References Cited

U.S. PATENT DOCUMENTS

2,842,129	A	7/1958	Ernstorff	6,849,065	B2	2/2005	Schmidt et al.
2,867,215	A	1/1959	Horton et al.	6,854,427	B2	2/2005	Frink
2,873,740	A	2/1959	Wainwright	6,932,797	B2	8/2005	Schmidt et al.
3,116,734	A	1/1964	Terman	7,018,366	B2	3/2006	Easter
3,194,238	A	7/1965	Breece, Jr.	7,207,601	B2 *	4/2007	Baharav B29C 65/342
3,349,768	A	10/1967	Keane				285/146.1
3,421,507	A *	1/1969	Gresham	7,358,282	B2	4/2008	Krueger et al.
			A61F 5/453	7,465,683	B2	12/2008	McMurray
			604/349	7,503,911	B2	3/2009	Mishima et al.
3,424,163	A	1/1969	Gravdahl	7,588,560	B1	9/2009	Dunlop
D215,716	S *	10/1969	Miller	7,749,205	B2	7/2010	Tazoe et al.
3,518,164	A *	6/1970	Andelin	7,766,887	B2	8/2010	Burns
			A61J 19/00	7,833,169	B2	11/2010	Hannon
			435/30	7,875,010	B2	1/2011	Frazier et al.
3,528,423	A	9/1970	Lee	7,931,634	B2	4/2011	Swiecicki et al.
3,601,125	A	8/1971	Moss	7,993,311	B2	8/2011	Finger et al.
3,608,552	A *	9/1971	Broerman	7,993,315	B2	8/2011	Matsuura
			A61F 5/453	8,177,760	B2	5/2012	Rome et al.
			604/349	8,187,238	B1	5/2012	Dupree
3,683,914	A	8/1972	Crowley	8,287,508	B1	10/2012	Sanchez
3,742,953	A	7/1973	Lee	8,328,792	B2	12/2012	Nishtala et al.
3,906,952	A	9/1975	Zamist	D674,895	S *	1/2013	Rubin
3,918,433	A	11/1975	Fuisz	8,394,074	B2	3/2013	Piette et al.
4,023,571	A	5/1977	Comerford et al.	8,403,901	B2	3/2013	Dunlop
4,194,508	A	3/1980	Anderson	8,454,568	B2	6/2013	Bourke
4,198,979	A	4/1980	Cooney et al.	8,475,422	B2 *	7/2013	Wu
4,200,102	A	4/1980	Duhamel et al.				A61F 5/453
4,239,044	A	12/1980	Pavlinch	8,491,552	B2	7/2013	House
4,246,901	A	1/1981	Frosch et al.	8,603,056	B1	12/2013	Fallis
4,270,539	A	6/1981	Frosch et al.	D704,330	S *	5/2014	Cicatelli
4,425,130	A	1/1984	DesMarais	8,998,882	B2	4/2015	Knapp et al.
4,610,675	A	9/1986	Truinfol	9,028,460	B2	5/2015	Medeiros
4,664,663	A	5/1987	Brier	9,033,149	B2	5/2015	Terry
4,747,166	A	5/1988	Kuntz	D739,006	S *	9/2015	Tominaga
4,769,099	A	9/1988	Therriault et al.	D760,893	S *	7/2016	Honda
4,784,654	A	11/1988	Beecher	D784,528	S *	4/2017	Burgess
4,795,449	A	1/1989	Schneider et al.	D800,334	S *	10/2017	Kasuto
D299,865	S *	2/1989	Kamstrup-Larsen	D802,102	S *	11/2017	Mursu
4,882,794	A	11/1989	Stewart	D818,116	S *	5/2018	Teufel
4,994,051	A	2/1991	Walsh	9,987,480	B2	6/2018	McDaniel
5,002,541	A	3/1991	Conkling et al.	10,226,376	B2	3/2019	Sanchez et al.
5,049,144	A	9/1991	Payton	D851,238	S *	6/2019	Ratner
5,078,707	A	1/1992	Klug				A61M 16/06
5,084,037	A	1/1992	Barnett	D851,747	S *	6/2019	Hu
5,195,997	A	3/1993	Carns				D24/110
5,267,969	A	12/1993	Hirsch et al.	10,376,406	B2	8/2019	Newton
5,312,379	A	5/1994	Rahe	10,376,407	B2	8/2019	Newton
5,312,383	A	5/1994	Kubalak	10,390,989	B2	8/2019	Sanchez
5,346,483	A	9/1994	Thaxton, Sr.	D864,774	S *	10/2019	Lei
5,366,449	A	11/1994	Gilberg				F16L 37/0885
5,413,117	A	5/1995	Wills	D873,996	S *	1/2020	Sanders
5,424,265	A	6/1995	Weinstein				A61M 39/10
D361,823	S *	8/1995	Layton	10,675,175	B2	6/2020	Holt
5,514,091	A	5/1996	Yoon	10,682,124	B2	6/2020	Duval
5,618,277	A	4/1997	Goulter	10,690,655	B2	6/2020	Duval
5,669,893	A	9/1997	Tanghøj	D896,930	S *	9/2020	Vranish
5,674,212	A	10/1997	Osborn et al.	D901,036	S *	11/2020	Wahba
5,685,870	A	11/1997	Tanghøj	D910,200	S *	2/2021	Reber
5,693,001	A	12/1997	Salama				A61F 2/0009
5,797,890	A	8/1998	Goulter et al.	D920,535	S *	5/2021	Crabtree
D409,303	S *	5/1999	Oepping	D923,195	S *	6/2021	Harding
5,957,904	A	9/1999	Holland				A61J 19/00
6,120,485	A	9/2000	Gustafsson et al.	D928,946	S	8/2021	Sanchez et al.
6,151,721	A	11/2000	Whitfield	D929,576	S *	8/2021	Motomura
6,183,454	B1	2/2001	Levine et al.	D929,578	S	8/2021	Johannes et al.
6,302,303	B1	10/2001	Reynolds	D930,184	S *	9/2021	Johnson
6,394,988	B1	5/2002	Hashimoto				A61F 5/453
D467,338	S	12/2002	Rehrig	11,141,307	B2	10/2021	Doreswamy
6,544,242	B1	4/2003	Kido et al.	D938,062	S *	12/2021	Werth
6,641,567	B1	11/2003	Williams	2002/0138058	A1	9/2002	Mishima et al.
6,648,835	B1 *	11/2003	Shemesh	2003/0004436	A1	1/2003	Schmidt et al.
			A61B 5/15003	2003/0010700	A1	1/2003	Schmidt et al.
			600/573	2003/0185330	A1	10/2003	Hessel et al.
6,684,414	B1	2/2004	Rehrig	2003/0208112	A1	11/2003	Schmidt et al.
6,699,174	B1	3/2004	Bennett	2004/0015141	A1	1/2004	Cheng et al.
6,702,793	B1	3/2004	Sweetser	2004/0035372	A1	2/2004	Frink
6,740,066	B2	5/2004	Wolff et al.	2004/0068780	A1	4/2004	Scott
6,761,710	B2	7/2004	D'acchioli et al.	2004/0079687	A1	4/2004	Muller et al.
6,840,925	B2	1/2005	Mishima et al.				

(56)

References Cited

U.S. PATENT DOCUMENTS

2004/0138638 A1 7/2004 Mishima et al.
 2004/0143229 A1 7/2004 Easter
 2004/0236292 A1 11/2004 Tazoe et al.
 2005/0075615 A1 4/2005 Bonham
 2005/0101939 A1 5/2005 Mitchell
 2005/0112975 A1 5/2005 McMurray
 2005/0112976 A1 5/2005 McMurray et al.
 2005/0137557 A1 6/2005 Swiecicki et al.
 2006/0015080 A1 1/2006 Mahnensmith
 2006/0069359 A1 3/2006 Dipalma et al.
 2006/0155214 A1 7/2006 Wightman
 2007/0035405 A1 2/2007 Wada et al.
 2007/0088327 A1* 4/2007 Guala A61M 39/10
 604/533
 2007/0265589 A1 11/2007 Kitamura
 2008/0183157 A1 7/2008 Walters
 2008/0281282 A1 11/2008 Finger et al.
 2008/0287894 A1 11/2008 Van Den et al.
 2008/0300448 A1 12/2008 Frazier et al.
 2009/0048569 A1 2/2009 Salehi
 2009/0078023 A1 3/2009 Mutharasan et al.
 2009/0131916 A1 5/2009 Chiu et al.
 2009/0270822 A1 10/2009 Medeiros
 2009/0306610 A1 12/2009 Van Den et al.
 2010/0010459 A1 1/2010 Piette et al.
 2010/0234820 A1 9/2010 Tsai et al.
 2010/0274156 A1 10/2010 Gorres
 2010/0278518 A1 11/2010 Gordon
 2011/0028922 A1 2/2011 Kay et al.
 2011/0028944 A1 2/2011 Chiu et al.
 2011/0040271 A1 2/2011 Rogers
 2011/0046514 A1 2/2011 Greenwald et al.
 2011/0064586 A1 3/2011 Matsumiya
 2011/0178425 A1 7/2011 Nishtala et al.
 2011/0251572 A1 10/2011 Nishtala et al.
 2011/0265889 A1 11/2011 Tanaka et al.
 2013/0053804 A1 2/2013 Sorensen et al.
 2013/0253457 A1* 9/2013 Shubin, Sr. A61D 19/021
 604/349
 2014/0033728 A1 2/2014 Marmilic et al.
 2015/0112228 A1 4/2015 Ekema et al.
 2015/0320583 A1 11/2015 Harvie
 2016/0310711 A1 10/2016 Luxon et al.
 2017/0196726 A1 7/2017 SanAntonio
 2017/0238911 A1 8/2017 Duval
 2017/0280783 A1 10/2017 Nough
 2017/0333244 A1 11/2017 Laniado
 2017/0363237 A1* 12/2017 Pepe F16L 37/0885
 2018/0031461 A1 2/2018 Steckmann et al.
 2018/0098877 A1 4/2018 Pierson
 2018/0188231 A1 7/2018 Barakat et al.
 2018/0228642 A1 8/2018 Davis
 2018/0256386 A1 9/2018 Pierson
 2019/0021899 A1* 1/2019 Vlet A61F 2/0009
 2019/0038451 A1 2/2019 Harvie
 2019/0314189 A1 10/2019 Acosta
 2020/0229964 A1 7/2020 Staali et al.
 2021/0000637 A1 1/2021 VanMiddendorp et al.
 2021/0023279 A1 1/2021 Radl et al.
 2021/0038423 A1 2/2021 Marvinac
 2021/0059853 A1 3/2021 Davis et al.
 2021/0113749 A1 4/2021 Radl et al.
 2021/0170079 A1 6/2021 Radl et al.
 2021/0177643 A1 6/2021 Challa et al.
 2021/0285584 A1* 9/2021 Ravisankar F16L 37/0926
 2021/0361463 A1* 11/2021 Duval A61F 5/441
 2021/0393433 A1 12/2021 Godinez
 2021/0401613 A1 12/2021 Chiang

FOREIGN PATENT DOCUMENTS

CN 205683177 11/2016
 CN 206372178 8/2017
 CN 207306773 5/2018

CN 208525189 2/2019
 CN 209899730 1/2020
 CN 210250222 4/2020
 CN 210962545 7/2020
 CN 212186998 12/2020
 CN 212214090 12/2020
 CN 213346264 6/2021
 CN 213430912 6/2021
 CN 214858088 11/2021
 CN 113730081 12/2021
 DE 19602299 7/1997
 DE 102007020517 7/2008
 DE 102013011493 2/2014
 EP 0613355 1/1997
 EP 0 951 881 6/2000
 FR 2690842 11/1993
 GB 8814874 1/1989
 JP 3053257 10/1998
 JP H 11502736 3/1999
 JP 2001-087298 4/2001
 JP 2008511360 4/2008
 JP 2012-509489 11/2008
 JP 2010-166954 8/2010
 JP S-4987689 7/2012
 JP S-5116492 1/2013
 JP 2015-147040 8/2015
 JP 5911232 4/2016
 JP S-5946519 7/2016
 JP 2019-512672 5/2019
 KR 20160038625 4/2016
 NL 8601391 10/1987
 SE 467086 5/1992
 TW M564441 8/2018
 TW 202200092 1/2022
 WO WO 1996/011652 4/1996
 WO WO 1997/001316 1/1997
 WO WO 03022333 3/2003
 WO WO 2004/019836 3/2004
 WO WO 2005/051252 6/2005
 WO WO 2007/058461 5/2007
 WO WO 2008/102808 8/2008
 WO WO 2009/004291 1/2009
 WO WO 2017/142723 8/2017
 WO WO 2017/142724 8/2017
 WO WO 2021/007345 1/2021
 WO WO 2021/007349 1/2021
 WO WO 2021090621 5/2021

OTHER PUBLICATIONS

Newman, D., Excerpts from The Urinary Incontinence Sourcebook, Lowell House, 1997, in 23 pages.
 International Preliminary Report on Patentability issued in PCT Application No. PCT/US2017/016624, dated Aug. 21, 2018, in 9 pages.
 International Preliminary Report on Patentability issued in PCT Application No. PCT/US2017/016626, dated Aug. 21, 2018, in 6 pages.
 International Search Report & Written Opinion issued in application No. PCT/US2021/020930, dated Sep. 1, 2021.
 International Search Report and Written Opinion issued in PCT Application No. PCT/US2017/016624, dated Apr. 28, 2017, in 11 pages.
 International Search Report and Written Opinion issued in PCT Application No. PCT/US2017/016626, dated Apr. 21, 2017, in 7 pages.
 Notice of Allowance issued in JP application No. 2018-543605, dated Jan. 5, 2021.
 Notification of Prior Art issued in JP application No. 2020-025536, dated Dec. 20, 2021.

* cited by examiner

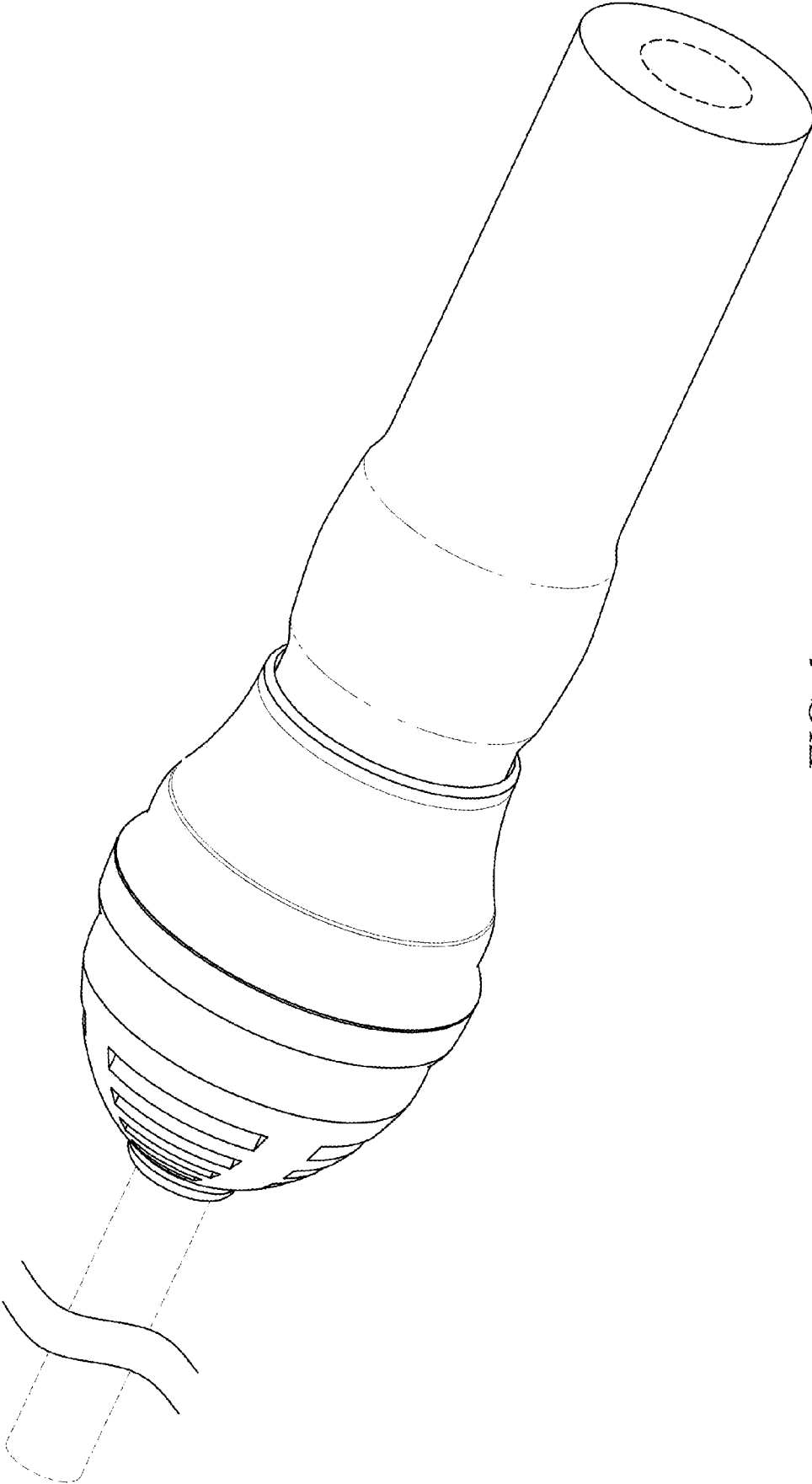

FIG. 1

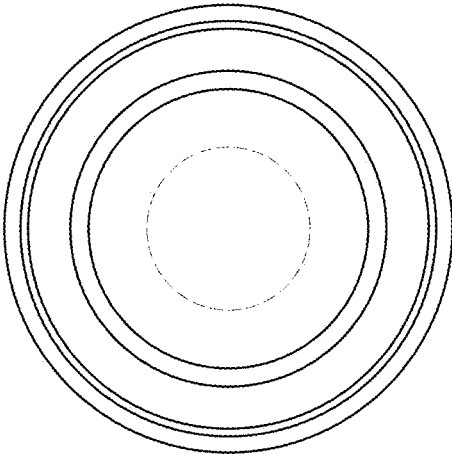

FIG. 3

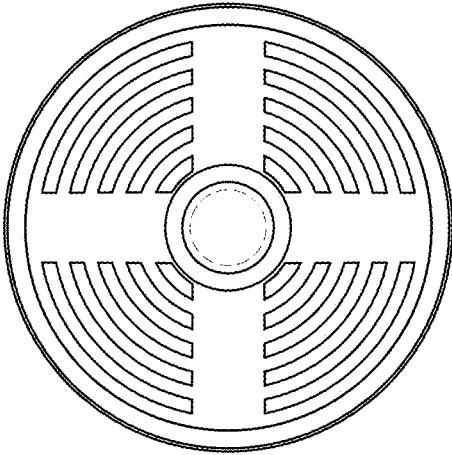

FIG. 2

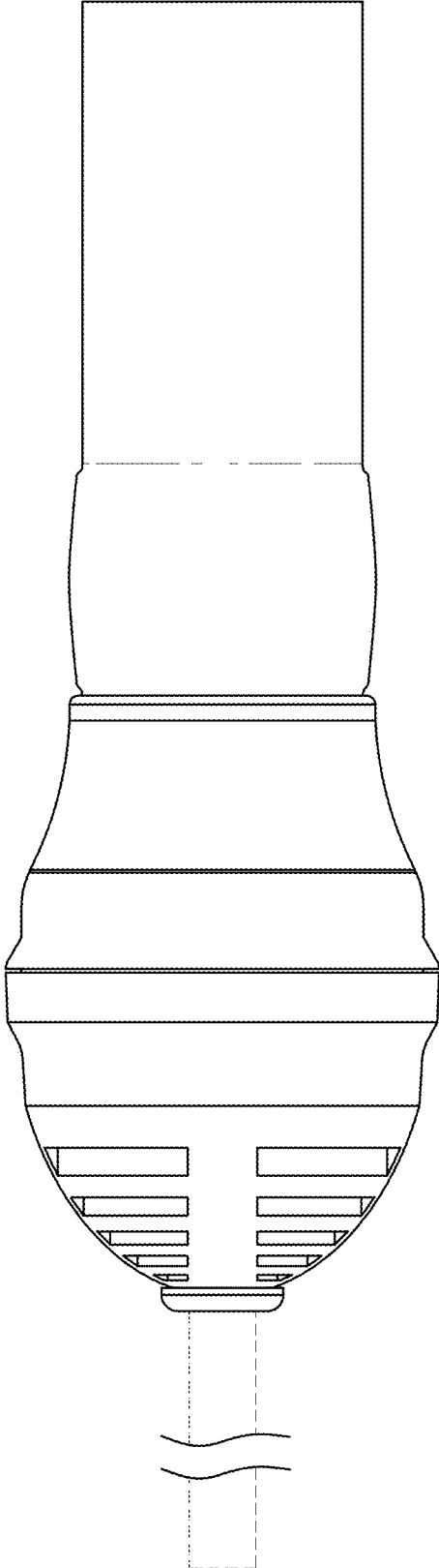

FIG. 4

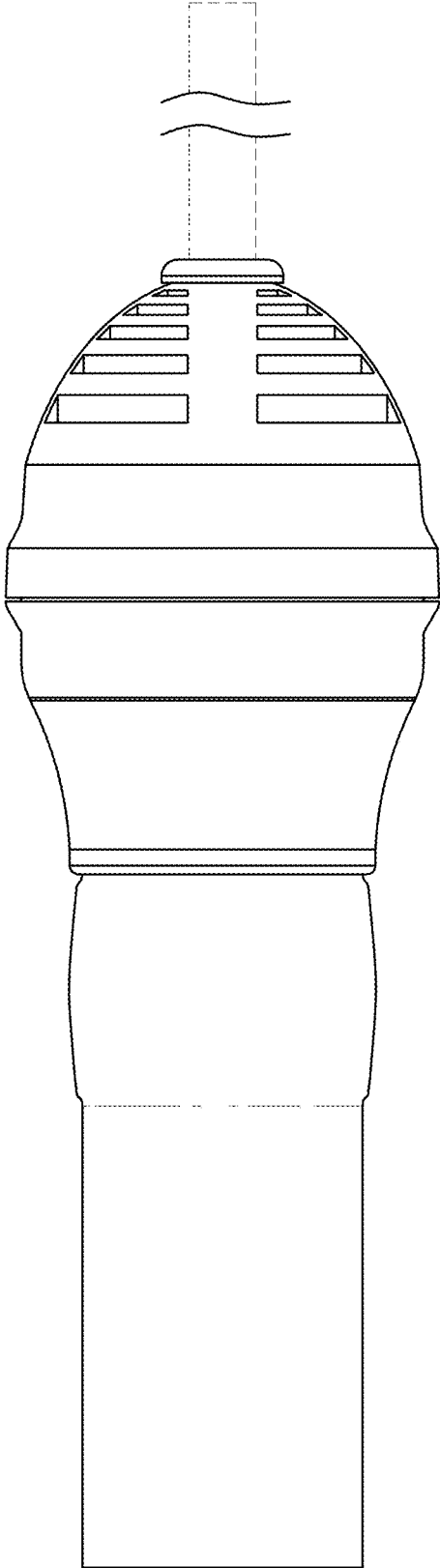

FIG. 5

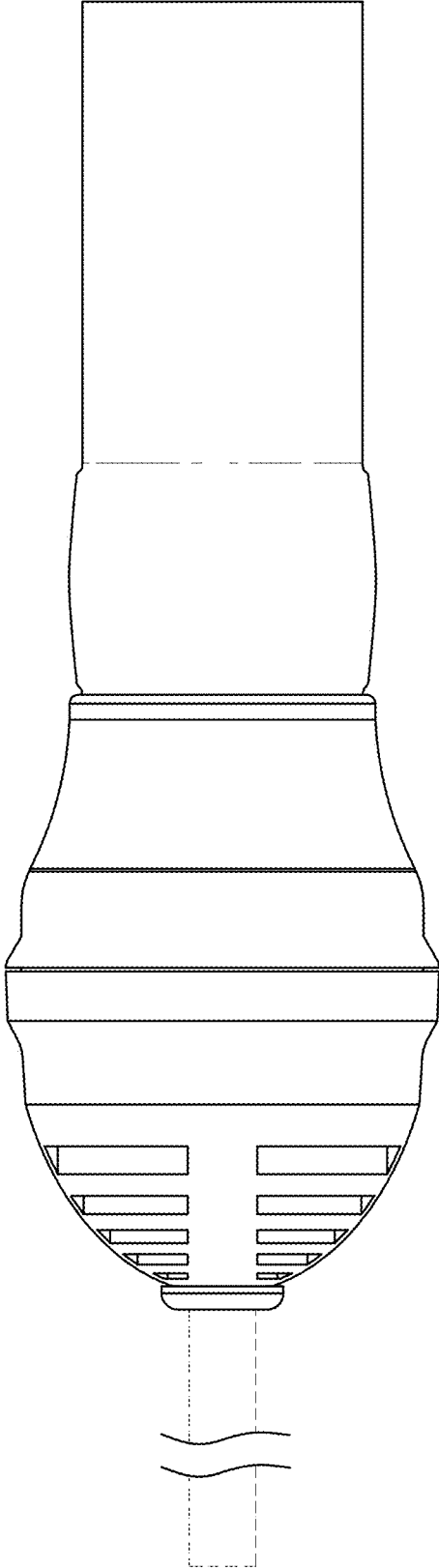

FIG. 6

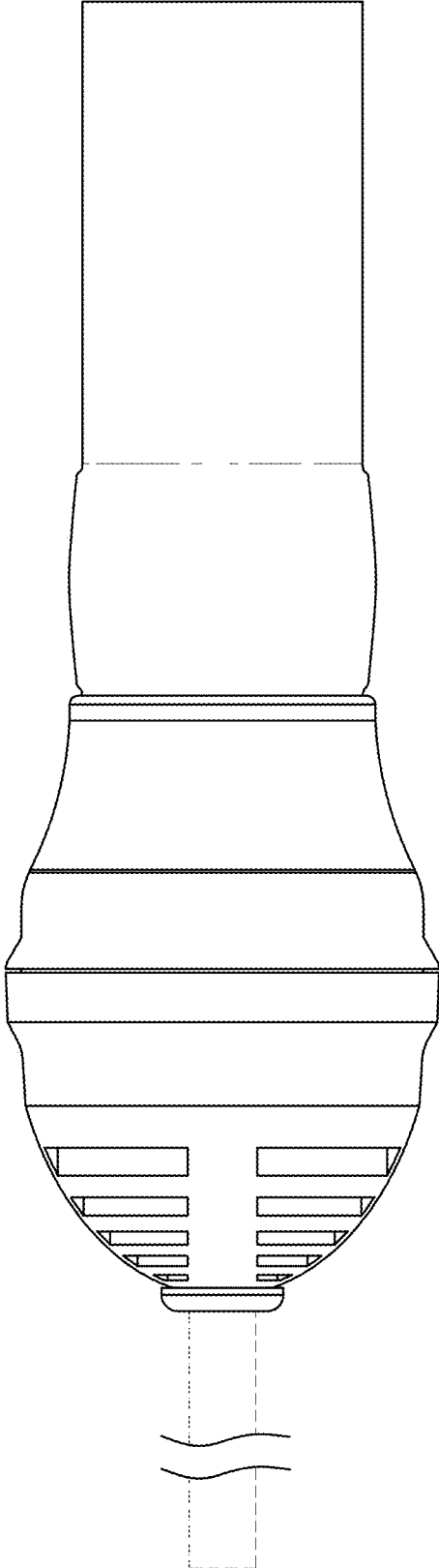

FIG. 7