



## INTERNATIONAL APPLICATION PUBLISHED UNDER THE PATENT COOPERATION TREATY (PCT)

<p>(51) International Patent Classification <sup>6</sup> : <b>H01Q 1/24, 5/00</b></p>	<p><b>A1</b></p>	<p>(11) International Publication Number: <b>WO 00/03451</b></p> <p>(43) International Publication Date: 20 January 2000 (20.01.00)</p>
<p>(21) International Application Number: PCT/SE99/01048</p> <p>(22) International Filing Date: 14 June 1999 (14.06.99)</p> <p>(30) Priority Data: 9802468-0                      9 July 1998 (09.07.98)                      SE</p> <p>(71) Applicant (for all designated States except US): MOTECO AB [SE/SE]; P.O. Box 51, S-570 76 Ruda (SE).</p> <p>(72) Inventor; and (75) Inventor/Applicant (for US only): BLOM, Carl, Gustaf [SE/SE]; Kvarnberget 2, S-453 33 Lysekil (SE).</p> <p>(74) Agent: WALLENGREN, Yngvar; Patentbyrån Y Wallengren AB, P.O. Box 116, S-331 21 Värnamo (SE).</p>	<p>(81) Designated States: AL, AM, AT, AU, AZ, BA, BB, BG, BR, BY, CA, CH, CN, CU, CZ, DE, DK, EE, ES, FI, GB, GD, GE, GH, GM, HR, HU, ID, IL, IN, IS, JP, KE, KG, KP, KR, KZ, LC, LK, LR, LS, LT, LU, LV, MD, MG, MK, MN, MW, MX, NO, NZ, PL, PT, RO, RU, SD, SE, SG, SI, SK, SL, TJ, TM, TR, TT, UA, UG, US, UZ, VN, YU, ZW, ARIPO patent (GH, GM, KE, LS, MW, SD, SL, SZ, UG, ZW), Eurasian patent (AM, AZ, BY, KG, KZ, MD, RU, TJ, TM), European patent (AT, BE, CH, CY, DE, DK, ES, FI, FR, GB, GR, IE, IT, LU, MC, NL, PT, SE), OAPI patent (BF, BJ, CF, CG, CI, CM, GA, GN, GW, ML, MR, NE, SN, TD, TG).</p> <p><b>Published</b> <i>With international search report.</i> <i>Before the expiration of the time limit for amending the claims and to be republished in the event of the receipt of amendments.</i> <i>In English translation (filed in Swedish).</i></p>	

(54) Title: A DUAL BAND ANTENNA

(57) Abstract

A dual band antenna for a so-called mobile telephone comprises a supply conductor (5) which is connected to the circuits of the mobile telephone. The supply conductor (5) is galvanically connected to a first antenna section (8) which is approximately planar and has a number of loop-shaped conductor members (10). The conductor members (10) are galvanically connected in series and are disposed in sequence after one another in the longitudinal direction (14) of the antenna. The conductor member (10) which is located most distally from the supply conductor (5) is galvanically connected to a second antenna section (9). The second antenna section (9) is substantially straight and essentially parallel with the longitudinal direction (14) of the antenna.

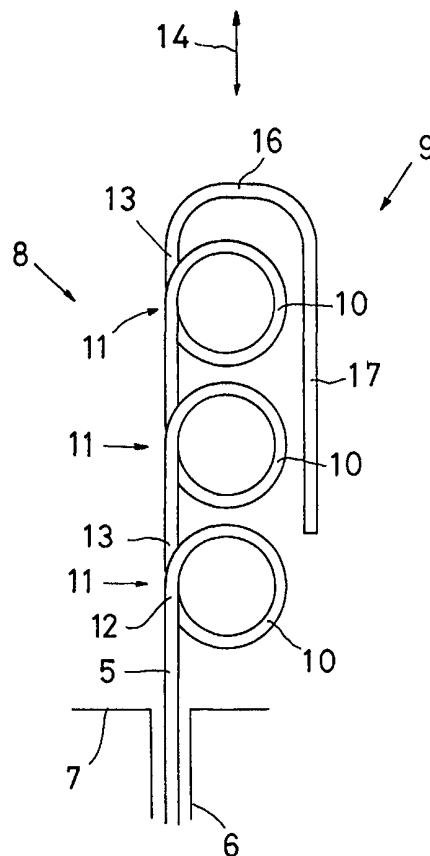

**FOR THE PURPOSES OF INFORMATION ONLY**

Codes used to identify States party to the PCT on the front pages of pamphlets publishing international applications under the PCT.

<b>AL</b>	Albania	<b>ES</b>	Spain	<b>LS</b>	Lesotho	<b>SI</b>	Slovenia
<b>AM</b>	Armenia	<b>FI</b>	Finland	<b>LT</b>	Lithuania	<b>SK</b>	Slovakia
<b>AT</b>	Austria	<b>FR</b>	France	<b>LU</b>	Luxembourg	<b>SN</b>	Senegal
<b>AU</b>	Australia	<b>GA</b>	Gabon	<b>LV</b>	Latvia	<b>SZ</b>	Swaziland
<b>AZ</b>	Azerbaijan	<b>GB</b>	United Kingdom	<b>MC</b>	Monaco	<b>TD</b>	Chad
<b>BA</b>	Bosnia and Herzegovina	<b>GE</b>	Georgia	<b>MD</b>	Republic of Moldova	<b>TG</b>	Togo
<b>BB</b>	Barbados	<b>GH</b>	Ghana	<b>MG</b>	Madagascar	<b>TJ</b>	Tajikistan
<b>BE</b>	Belgium	<b>GN</b>	Guinea	<b>MK</b>	The former Yugoslav Republic of Macedonia	<b>TM</b>	Turkmenistan
<b>BF</b>	Burkina Faso	<b>GR</b>	Greece	<b>ML</b>	Mali	<b>TR</b>	Turkey
<b>BG</b>	Bulgaria	<b>HU</b>	Hungary	<b>MN</b>	Mongolia	<b>TT</b>	Trinidad and Tobago
<b>BJ</b>	Benin	<b>IE</b>	Ireland	<b>MR</b>	Mauritania	<b>UA</b>	Ukraine
<b>BR</b>	Brazil	<b>IL</b>	Israel	<b>MW</b>	Malawi	<b>UG</b>	Uganda
<b>BY</b>	Belarus	<b>IS</b>	Iceland	<b>MX</b>	Mexico	<b>US</b>	United States of America
<b>CA</b>	Canada	<b>IT</b>	Italy	<b>NE</b>	Niger	<b>UZ</b>	Uzbekistan
<b>CF</b>	Central African Republic	<b>JP</b>	Japan	<b>NL</b>	Netherlands	<b>VN</b>	Viet Nam
<b>CG</b>	Congo	<b>KE</b>	Kenya	<b>NO</b>	Norway	<b>YU</b>	Yugoslavia
<b>CH</b>	Switzerland	<b>KG</b>	Kyrgyzstan	<b>NZ</b>	New Zealand	<b>ZW</b>	Zimbabwe
<b>CI</b>	Côte d'Ivoire	<b>KP</b>	Democratic People's Republic of Korea	<b>PL</b>	Poland		
<b>CM</b>	Cameroon	<b>KR</b>	Republic of Korea	<b>PT</b>	Portugal		
<b>CN</b>	China	<b>KZ</b>	Kazakstan	<b>RO</b>	Romania		
<b>CU</b>	Cuba	<b>LC</b>	Saint Lucia	<b>RU</b>	Russian Federation		
<b>CZ</b>	Czech Republic	<b>LI</b>	Liechtenstein	<b>SD</b>	Sudan		
<b>DE</b>	Germany	<b>LR</b>	Sri Lanka	<b>SE</b>	Sweden		
<b>DK</b>	Denmark	<b>LR</b>	Liberia	<b>SG</b>	Singapore		
<b>EE</b>	Estonia						

## A DUAL BAND ANTENNA

## TECHNICAL FIELD

5 The present invention relates to a dual band antenna for a portable radiocommunications apparatus, a so-called mobile telephone, and comprises a supply conductor which is connected to the circuits of the mobile telephone.

## 10 BACKGROUND ART

In the construction of portable radiocommunications apparatuses, so-called mobile telephones, it is becoming increasingly common that these are designed to be able to operate in two different frequency bands. As far as  
15 Europe is concerned, this applies to the two frequency bands GSM on 890-960 MHz and DCS on 1710-1880 MHz. For the United States, the bands involved are, for instance, E-AMPS on 824-894 MHz and PCS on 1850-1990 MHz. Such a mobile telephone which operates in dual frequency bands would in principle need four different antenna functions, in which one  
20 antenna function is employed in each one of the frequency bands in the stand-by position, so-called paging mode, of the apparatus and in which one antenna function is employed in each one of the frequency bands in the active state of the apparatus, the talk position. A first step in reducing the physical dimensions of the antennae entails that dual band antennae are  
25 employed. However, in the paging mode these have often been far too bulky if they are to have the desired efficiency and band width.

## PROBLEM STRUCTURE

30 The present invention has for its object to design the antenna intimated by way of introduction such that it has superior efficiency in two frequency bands, with extremely compact dimensions. In addition, the present invention has for its object to design the antenna such that, without an intermediate connection of an adaptation network, it can be directly  
35 connected to the circuits of the mobile telephone and that it may be both

simple and economical to manufacture and, when necessary, be cast in an insulator so as to form a discrete unit.

## SOLUTION

5

The objects forming the basis of the present invention will be attained if the antenna intimated by way of introduction is characterized in that the supply conductor is galvanically connected with or merges in a first antenna section which is approximately planar and which includes a number of loop-shaped conductor members which are mutually galvanically connected in series and  
10 which are disposed in sequence after one another in the longitudinal direction of the antenna, and that the loop-shaped conductor member located most distally from the supply conductor is galvanically connected with or merges in a second antenna section.

15

Further advantages will be attained if the antenna according to the present invention is given one or more of the characterizing features as set forth in appended Claims 2 to 12.

## 20 BRIEF DESCRIPTION OF THE ACCOMPANYING DRAWINGS

The present invention will now be described in greater detail hereinbelow, with particular reference to the accompanying Drawings. In the accompanying Drawings:

25

Fig. 1 schematically illustrates an upper portion of a mobile telephone and its antenna arrangement;

30

Fig. 2 is a vertical plan view of an antenna included in the antenna arrangement of Fig. 1;

Fig. 3 shows the antenna of Fig. 2 seen from the left in that Figure, and

35

Fig. 4 is an electric skeleton diagram of the antenna of Figs. 2 and 3.

## DESCRIPTION OF PREFERRED EMBODIMENT

As will have been apparent from the foregoing introduction, the present invention has for its object to realise a dual band antenna which has minimal physical dimensions. It is particularly advantageous if the antenna can be given a flat appearance so that it may be placed at the rear side of the mobile telephone and as a result be spaced as far away as possible from the user's head. In the following description, the expression "flat" or "approximately planar" or similar expressions will be employed relating to the antenna and components included therein. These expressions should not, however, be interpreted literally, but are also taken to signify designs and constructions which have a length, a width and a thickness and in which the thickness is considerably less than the length, often as much as by a factor of ten or more, while the width may amount to roughly half of the length.

In Fig. 1, reference numeral 1 relates to a part of a hood of a portable radiocommunications apparatus, in daily parlance a mobile telephone, which includes electric circuits for transmitting and receiving radio waves within two different frequency bands. The broken lines at reference numeral 2 show the outer contour of a casing which at least partly encloses the antenna unit according to the present invention. The antenna unit includes a first antenna element 3 which is wholly enclosed inside the outer contour 2 and which is intended to function during stand-by position, paging mode. The antenna unit further includes a second antenna element 4 which is intended to function in the talk position and which is designed to be excited or supplied by the first antenna element 3. In the illustrated embodiment, the second antenna element 4 is designed as a rod antenna which is displaceable in its longitudinal direction between a protracted, active position and an inactive position largely retracted in the hood. The rod antenna 4 is long and may be set to  $\lambda/2$  or  $\lambda$ .

The detailed construction of one embodiment of the first antenna element 3 is apparent from Figs. 2 and 3 taken as whole. The antenna element has a supply conductor 5 which is galvanically connected to the coaxial cable 6 which directly (without the interconnection of an adaptation network) connects the antenna to the electric circuits of the mobile telephone. The

coaxial cable 6 earths (grounds) the antenna in hood 1 of the mobile telephone or in an electrically conductive chassis which is located inside the hood and is illustrated by reference numeral 7.

- 5 The antenna includes a first antenna section 8 which is intended to function in the higher of the two frequency bands in which the antenna is to operate, and a second antenna section 9 which, together with the first antenna section 8, operates in the lower of the two frequency bands for which the antenna is constructed.

10

It will be apparent from the Figures that the two antenna sections 8 and 9 together form a substantially planar or flat unit which, in the thickness direction (at right angles to the plane of the paper in Fig. 2 and left to right in Fig. 3) is of considerably lesser extent than that which applies in the longitudinal direction 14 of the antenna and also in its width direction. Preferably, the thickness is less than the length by of the order of magnitude of a power of ten.

15

In the illustrated embodiment, the first antenna section 8 includes three loop-shaped conductor members 10 disposed in sequence after one another and which, as will be apparent from Fig. 2, may be substantially circular and may be described as helical formations which comprise one turn and which have but insignificant pitch. While the loop-shaped conductor members 10 are illustrated as being circular, it is not necessary to give them the form of a perfect circle, but they may be elliptical, polygonal or an intermediate form in between.

20

25

The loop-shaped conductor members 10 have, in the illustrated embodiment, the same diameter and are disposed in line after one another, seen in the longitudinal direction of the antenna, and also have their centre points located on a straight line which is substantially parallel with the longitudinal direction of the antenna.

30

Within each loop-shaped conductor member 10, there is an overlap zone 11 where the conductor 12 which, counting from the supply conductor 5, is ingoing into the loop-shaped conductor member 10 and the outgoing

35

conductor 13 which departs from it overlap or possibly intersect one another. These ingoing and outgoing conductors are galvanically separate and discrete from one another in that, as is apparent from Fig. 3, interspaces 18 are disposed between the closely adjacent conductors.

5

In terms of manufacture, the absence of galvanic contact between the conductors within the overlap zones 11 may be achieved in that the antenna element 3 is manufactured from a metal wire with an insulating layer. Alternatively, the antenna element 3 may be produced with an inherent pretensioning which will have as a result that closely adjacent conductors within the overlap zones 11 strive away from one another. By casting in an insulating plastic material, the conductors are fixed in the correct position.

10

In the lower overlap zone 11 illustrated in Fig. 2, the ingoing conductor has, as will have been apparent from the foregoing, been given reference numeral 12, while the outgoing conductor has been given reference numeral 13.

15

Seen in the longitudinal direction of the antenna, which is illustrated by the arrow 14, the loop-shaped conductor members 10 are spaced apart from one another as shown at reference numeral 15. This spacing may amount to half of the diameter of one loop-shaped conductor member but is preferably less and may possibly approach zero. On the other hand, it cannot be negative, which would imply that two loop-shaped conductor members 10 overlap one another in the longitudinal direction 14 of the antenna. The spacing 15 is equal throughout the entire length of the antenna.

20

25

The loop-shaped conductor member 10 which is located most distally from the supply conductor 5 has its outgoing conductor 13, a slight distance from the loop-shaped conductor member, bent transversely of the longitudinal direction 14 of the antenna, so that there is thereby formed a transverse conductor section 16. This is bent such that the straight conductor section 17 located after the bend will have a longitudinal direction which is substantially parallel with the longitudinal direction 14 of the antenna. Further, the orientation of the transverse conductor section 16 and the conductor section 17 is such that both conductor sections lie substantially in the same plane as the three loop-shaped conductor members 10. The second

30

35

antenna section 9 consists of at least the longitudinal, straight conductor section 17, but at least certain parts of the transverse conductor section 16 may also be included therein.

5 In Fig. 1, a first antenna element 3 has been shown with two loop-shaped conductor members 10, while, in Figs. 2 and 3 an embodiment is shown with three loop-shaped conductor members 10. According to the present invention, it is possible to employ, in the antenna section 8, even four or possibly five loop-shaped conductor members, as long as the wire length  
10 which is consumed for producing the loop-shaped conductor member is approximately the same in the same frequency. This implies that, in the embodiment according to Fig. 1, which has two loop-shaped conductor members, these will be of greater diameter than is the case in Fig. 2 where three loop-shaped conductor members are provided. Hence, the wire length  
15 is approximately the same if the setting frequencies are the same. Correspondingly, an antenna section with four or five loop-shaped conductor members would have a smaller diameter for these members and at the same time have a greater length in the antenna section, counting in the longitudinal direction 14.

20 What number of loop-shaped conductor members which is selected in each individual case (in approximately the same material length in the employed wire and in the same frequency) depends upon the characteristics the antenna is to have. With a physically short antenna, the band width of the  
25 antenna will be relatively slight, while it increases with the length of the antenna (with the number of loop-shaped conductor members within approximately the same material length). Further, the degree of efficiency increases with an increasing length of the antenna, so that an antenna with three or four loop-shaped conductor members may dispense with the  
30 second, rod-shaped antenna element 4.

As was mentioned above, the first antenna element 3 connects directly to the circuits of the mobile telephone without the employment of an intermediate adapter network. This is possible, given that the antenna element 3 in itself  
35 forms an adapter network with both capacitative and inductive components. In Fig. 4, this is illustrated in that capacitances between closely adjacent wire



portions are formed in the overlap zones 11. These adjacent wire portions are shown at the arrows C in the Figure. Correspondingly, the loop-shaped conductor members 10 form inductances which are illustrated by means of the arrows L. As will be apparent from the lower section of Fig. 4, each loop-shaped conductor member 10 may be represented by a capacitance C and an inductance L which are coupled in parallel with each other. These groups, which represent one loop-shaped conductor member 10 and which include a capacitance and an inductance, are connected in series, in sequence after one another and, in the end facing away from the coaxial cable 6 and the supply conductor 5, are connected to the second antenna section 9.

As was intimated in the foregoing, the antenna element 3 may be cast in a body of an electrically insulating material, for example plastic material, so that the antenna element 3 thereby forms a discrete unit. As a result, the different conductor members will also be fixed in relation to one another so that no change of the electric properties of the antenna, for example arising out of a change of the spacing 18 (Fig. 3) need be feared if the antenna were to be subjected to mechanical action. Given that the employed plastic material has a dielectricity constant which is greater than the dielectricity constant of air, a reduction of the physical dimensions of the antenna element will further be obtained.

In one practical embodiment of the antenna according to Figs. 2 and 3, the antenna is intended for the GSM and DCS bands. The antenna is cast in a plastic material displaying a dielectricity constant of the order of magnitude of 2 to 2.5. The wire employed for producing the antenna has a diameter of 1 mm. The inner diameter of the loop-shaped conductor members is approximately 4 mm, and the spacing 15 between them is approximately 0.5 mm, while the distance between the transverse conductor section 16 and the uppermost loop-shaped conductor member is approximately 1 mm. The length of the supply conductor 5 is approximately 2 mm counting up to the upper side of the lower loop-shaped conductor member. Further, the distance between the longitudinal conductor section 17 and the closely adjacent loop-shaped conductor members is approximately 1 mm. Finally, the distance 18 is approximately 0.2 mm, while coated wires 12 and 13 may abut against one another.

## DESCRIPTION OF ALTERNATIVE EMBODIMENTS

In the foregoing, the antenna element 3 has been described as manufactured from one-piece metal wire. However, the antenna element 3 could just as well be manufactured with the aid of a double-sided circuit card, which thus has an electrically conductive coating on its opposing sides. This would imply in Fig. 2 that, for example, the supply conductor 5 and the upper half of the lowermost loop-shaped conductor member 10 is produced on that side of the circuit card turned to face the observer, while the lower half of the lower loop-shaped conductor member is produced on the rear side of the circuit card together with the upper half of the centremost loop-shaped conductor member, as well as the conductor which interconnected the two lower conductor members with one another. Conductor connections straight through the circuit card interconnect conductive portions located on opposing sides of the card.

Above, the loop-shaped conductor members 10 have been described as being of equal size. In, for example, such situations where the outer form of the antenna is limited or determined beforehand, deviations from this rule may be made. Thus, the diameter may vary in the different loop-shaped conductor members 10, for example reduce from the bottom of the antenna towards its top. Furthermore, the centre points of them may be disposed along a curved line. Finally, the ingoing conductor 12 to the lower loop-shaped conductor member 10 in Fig. 2 may extend an additional approximately  $1/4$  of a turn in a counterclockwise direction so that the supply conductor 5 will be located approximately centrally beneath the antenna.

Concerning the longitudinal conductor 17, it is possible to cause it to make an angle with the longitudinal direction 14. Further, it may be placed ahead of (or behind) the loop-shaped conductor members 10 in Fig. 2, as well as being placed to their left. In the latter case, a greater band width in the lower frequency band is to be expected.

The present invention may be modified further without departing from the scope of the appended Claims.

**WHAT IS CLAIMED IS:**

1. A dual band antenna for a portable radiocommunications apparatus, a so-called mobile telephone, comprising a supply conductor (5) which is  
5 connected to the circuits of the mobile telephone, characterized in that the supply conductor (5) is galvanically connected with or merges in a first antenna section (8) which is approximately planar and which includes a number of loop-shaped conductor members (10) which are mutually galvanically connected in series and which are disposed in sequence after  
10 one another in a longitudinal direction (14) of the antenna; and that the loop-shaped conductor member located most distally from the supply conductor is galvanically connected with or merges in a second antenna section (9).
2. The antenna as claimed in Claim 1, characterized in that the second  
15 antenna section (9) includes a substantially straight conductor section (17) which is substantially parallel with the longitudinal direction (14) and which extends in a direction towards the supply conductor (5).
3. The antenna as claimed in any of Claims 1 or 2, characterized in that  
20 the second antenna section (9) is located in approximately the same plane as the first antenna section (8).
4. The antenna as claimed in any of Claims 1 to 3, characterized in that  
25 the loop-shaped conductor members (10) are disposed in slight spaced apart relationship (15) from one another counting in the longitudinal direction (14).
5. The antenna as claimed in any of Claims 1 to 4, characterized in that  
30 the loop-shaped conductor members (10) have approximately the same configuration, with their centre point disposed along an approximately straight line which is substantially parallel with the longitudinal direction (14).
6. The antenna as claimed in any of Claims 1 to 5, characterized in that  
35 the loop-shaped conductor members (10) have overlap zones (11) where the ingoing conductor (12) to the loop-shaped portion overlaps, possibly

intersects, the outgoing conductor (13) therefrom; and that the ingoing and outgoing conductors are galvanically discrete and separate from one another within the overlap zone.

- 5 7. The antenna as claimed in any of Claims 1 to 6, characterized in that  
the first antenna section (8) and the second antenna section (9) are of one  
piece manufacture from a wire of metal or metal alloy.
- 10 8. The antenna as claimed in any of Claims 1 to 6, characterized in that  
the first antenna section (8) and the second antenna section (9) are disposed  
on a double sided circuit card, where the first antenna section (8) has  
conductor portions on both sides of the circuit card.
- 15 9. The antenna as claimed in any of Claims 1 to 8, characterized in that  
the first antenna section (8) is set to the higher of the two frequency bands  
for which the antenna is intended to be operative.
- 20 10. The antenna as claimed in any of Claims 1 to 9, characterized in that  
the second antenna section (9) is set to cause the antenna in its entirety to  
operate in the lower of the two frequency bands for which the antenna is  
intended to be operative.
- 25 11. The antenna as claimed in any of Claims 1 to 10, characterized in that  
the supply conductor (5) is connected without adaptation network direct to  
the circuits of the mobile telephone.
12. The antenna as claimed in any of Claims 1 to 11, characterized in that  
it is disposed in the physical proximity of a rod antenna (4) for  
inductive/ capacitive supply thereof.

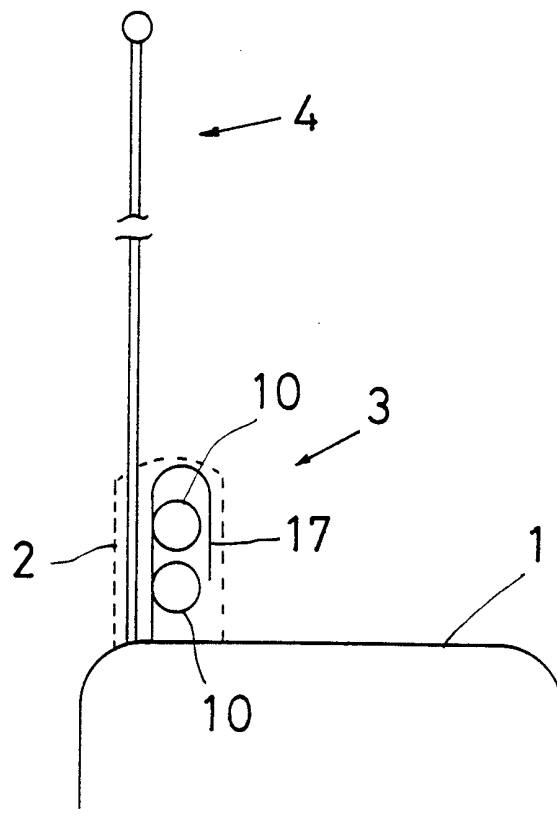

Fig 1

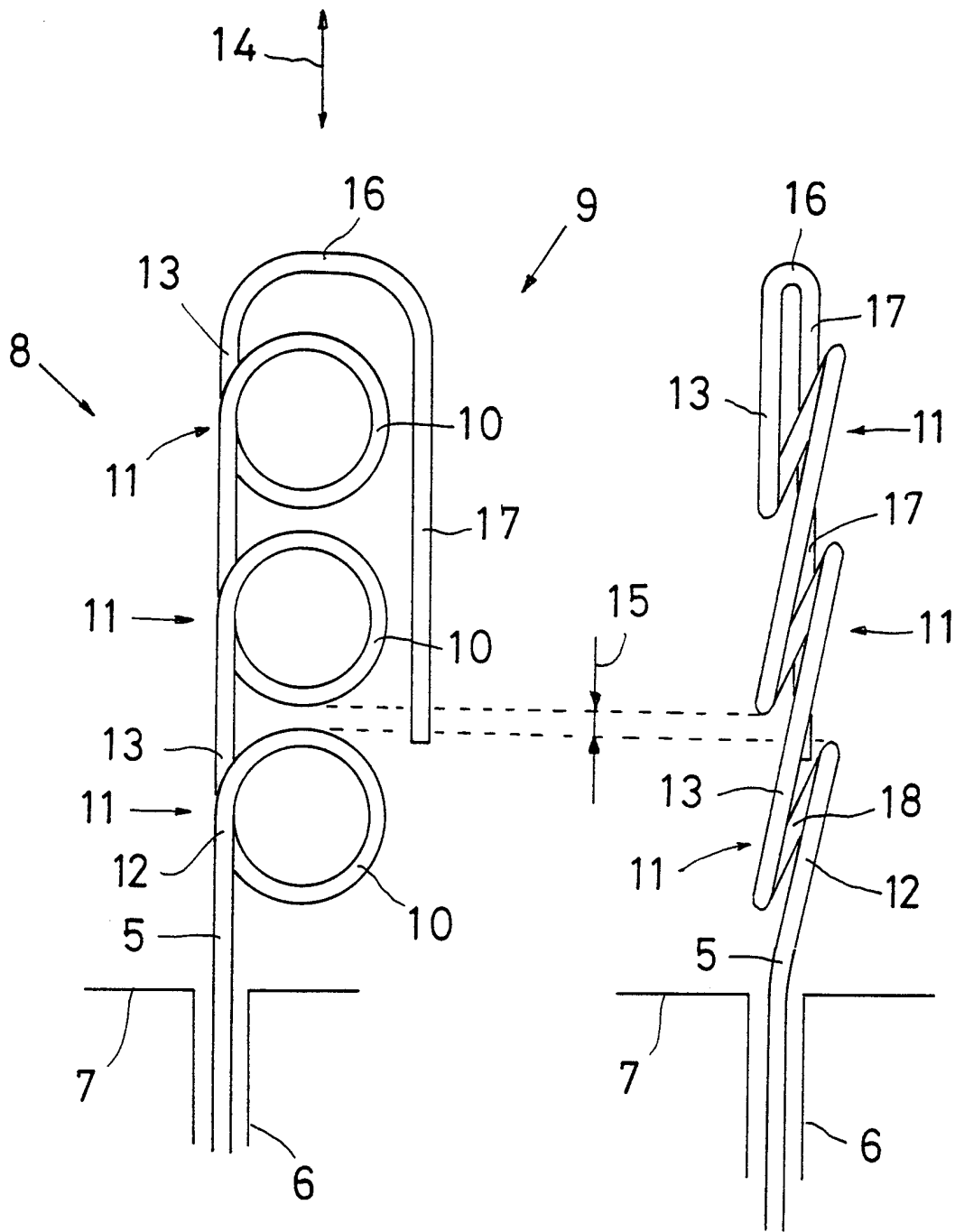

Fig 2

Fig 3

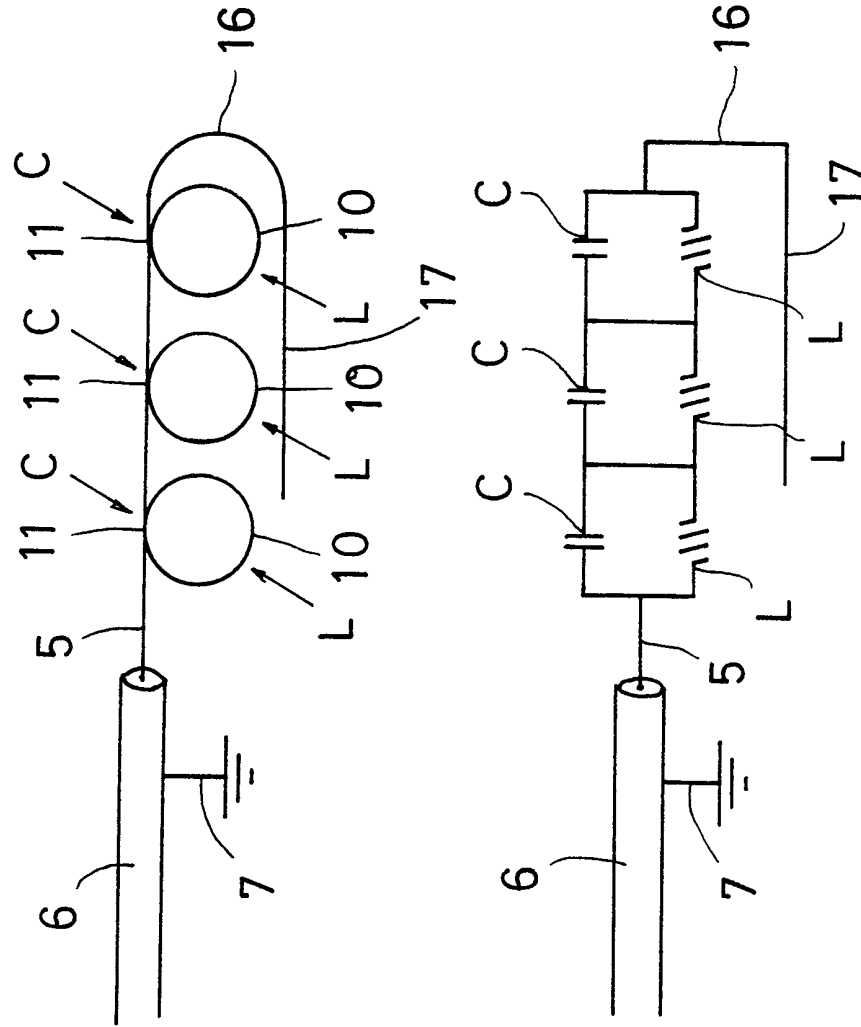

Fig 4

## INTERNATIONAL SEARCH REPORT

International application No.  
PCT/SE 99/01048

## A. CLASSIFICATION OF SUBJECT MATTER

**IPC6: H01Q 1/24, H01Q 5/00**  
According to International Patent Classification (IPC) or to both national classification and IPC

## B. FIELDS SEARCHED

Minimum documentation searched (classification system followed by classification symbols)

**IPC6: H01Q**

Documentation searched other than minimum documentation to the extent that such documents are included in the fields searched

**SE,DK,FI,NO classes as above**

Electronic data base consulted during the international search (name of data base and, where practicable, search terms used)

## C. DOCUMENTS CONSIDERED TO BE RELEVANT

Category*	Citation of document, with indication, where appropriate, of the relevant passages	Relevant to claim No.
A	US 5557293 A (DANNY MCCOY ET AL), 17 Sept 1996 (17.09.96), figure 1, abstract  --	1-12
A	EP 0767508 A2 (NOKIA MOBILE PHONES LTD), 9 April 1997 (09.04.97), figure 1, abstract  -- -----	1-12

Further documents are listed in the continuation of Box C.  See patent family annex.

\* Special categories of cited documents:

"A" document defining the general state of the art which is not considered to be of particular relevance  
 "E" earlier document but published on or after the international filing date  
 "I" document which may throw doubts on priority claim(s) or which is cited to establish the publication date of another citation or other special reason (as specified)  
 "O" document referring to an oral disclosure, use, exhibition or other means  
 "P" document published prior to the international filing date but later than the priority date claimed

"I" later document published after the international filing date or priority date and not in conflict with the application but cited to understand the principle or theory underlying the invention

"X" document of particular relevance: the claimed invention cannot be considered novel or cannot be considered to involve an inventive step when the document is taken alone

"Y" document of particular relevance: the claimed invention cannot be considered to involve an inventive step when the document is combined with one or more other such documents, such combination being obvious to a person skilled in the art

"&" document member of the same patent family

Date of the actual completion of the international search

**22 November 1999**

Date of mailing of the international search report

**24 -11- 1999**

Name and mailing address of the ISA/  
Swedish Patent Office  
Box 5055, S-102 42 STOCKHOLM  
Facsimile No. +46 8 666 02 86

Authorized officer

**Rune Bengtsson/MN**  
Telephone No. +46 8 782 25 00



**INTERNATIONAL SEARCH REPORT**

Information on patent family members

02/11/99

International application No.

PCT/SE 99/01048

Patent document cited in search report	Publication date	Patent family member(s)	Publication date
US 5557293 A	17/09/96	NONE	
EP 0767508 A2	09/04/97	GB 2306056 A	23/04/97
		GB 9520475 D	00/00/00
		IL 119353 D	00/00/00
		JP 9130288 A	16/05/97