



US0D1033628S

(12) **United States Design Patent**  
**Piper et al.**

(10) **Patent No.:** **US D1,033,628 S**

(45) **Date of Patent:** **\*\* Jul. 2, 2024**

- (54) **FLUID DELIVERY MODULE**
- (71) Applicant: **Luminoah, Inc.**, Charlottesville, VA (US)
- (72) Inventors: **Joseph Neal Piper**, Charlottesville, VA (US); **James Landon Gilkey**, Charlottesville, VA (US); **Brian Bergeron**, Charlottesville, VA (US); **Hill Johnson**, Charlottesville, VA (US); **Martin Eric Weiner**, Charlottesville, VA (US)
- (73) Assignee: **Luminoah, Inc.**, Charlottesville, VA (US)

- 6,554,798 B1 4/2003 Mann et al.
- 6,685,450 B2 2/2004 Bandis et al.
- 6,868,987 B2 3/2005 Hedington et al.
- 7,282,044 B2 10/2007 Hudson et al.
- 7,896,202 B2 3/2011 Greenwald et al.
- 8,021,322 B1 9/2011 Francis
- 8,083,503 B2 12/2011 Voltenburg, Jr. et al.
- 8,133,197 B2 3/2012 Blomquist et al.

(Continued)

**FOREIGN PATENT DOCUMENTS**

- AU 2007/335901 6/2008
- CA 2553335 8/2005

(Continued)

**OTHER PUBLICATIONS**

Sjoblom, Cindy, "Ambulatory Tube-Feeding", 2015, Umea Institute of Design, pp. 1-116.

(Continued)

*Primary Examiner* — Richard Kearney  
*Assistant Examiner* — Michael Hoffman  
(74) *Attorney, Agent, or Firm* — Casimir Jones, S.C.; Brian F. Bradley

- (\*\*) Term: **15 Years**
- (21) Appl. No.: **29/849,695**
- (22) Filed: **Aug. 12, 2022**
- (51) **LOC (14) Cl.** ..... **24-02**
- (52) **U.S. Cl.**  
USPC ..... **D24/111**
- (58) **Field of Classification Search**  
USPC ..... D24/107, 108, 111, 169, 185, 186  
CPC .... A61M 5/142; A61M 5/1452; A61M 5/168;  
A61M 5/16886; A61M 2205/502; A61M  
2205/505; A61M 2205/3331; A61M  
2205/3334; A61M 2205/8206  
See application file for complete search history.

(57) **CLAIM**  
The ornamental design for a fluid delivery module, as shown and described.

**DESCRIPTION**

FIG. 1 is a perspective view showing our new design of a fluid delivery module;  
FIG. 2 is a front view thereof;  
FIG. 3 is a rear view thereof;  
FIG. 4 is a right side view thereof;  
FIG. 5 is a left side view thereof;  
FIG. 6 is a top view thereof; and,  
FIG. 7 is a bottom view thereof.

**1 Claim, 5 Drawing Sheets**

- (56) **References Cited**  
**U.S. PATENT DOCUMENTS**  
4,091,689 A 5/1978 Huffman  
4,529,102 A 7/1985 Quinn et al.  
4,552,561 A \* 11/1985 Ekenhoff ..... A61M 5/145  
604/892.1  
4,640,445 A 2/1987 Yamada  
5,074,846 A 12/1991 Clegg et al.  
D325,255 S \* 4/1992 Busche ..... D24/111  
6,039,714 A 3/2000 Cracauer et al.

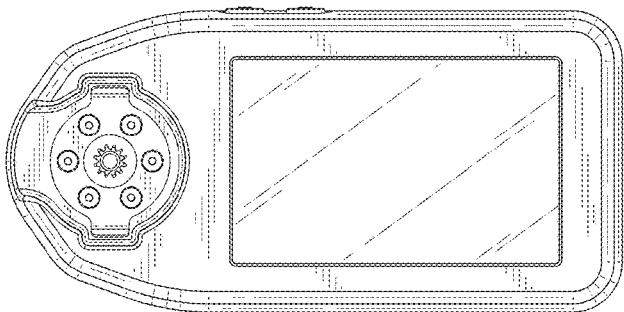
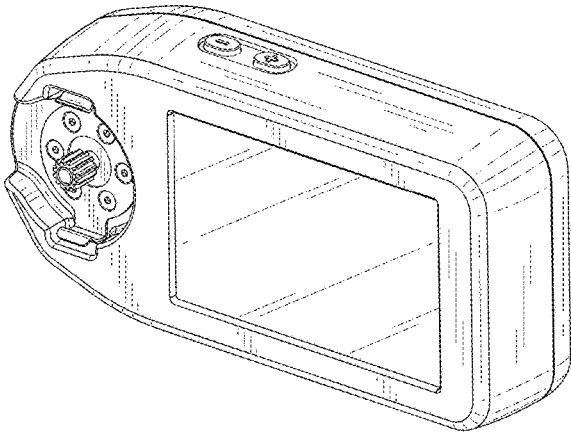

(56)

References Cited

U.S. PATENT DOCUMENTS

8,157,813 B2 4/2012 Ko et al.  
 8,157,816 B2 4/2012 Rotella et al.  
 8,177,742 B1 5/2012 Bagwell et al.  
 D689,523 S \* 9/2013 Galbraith ..... D15/7  
 D691,258 S \* 10/2013 Estes ..... D24/111  
 8,579,870 B2 11/2013 Willis et al.  
 8,628,509 B2 1/2014 Kropczynski, Jr. et al.  
 8,641,618 B2 2/2014 Jennewine et al.  
 8,668,675 B2 3/2014 Chase et al.  
 8,905,731 B2 12/2014 Baron  
 8,951,232 B2 2/2015 Fitzgerald et al.  
 9,022,653 B2 5/2015 Pittet et al.  
 9,114,209 B2 8/2015 Estes et al.  
 9,180,244 B2 11/2015 Anderson et al.  
 D752,736 S \* 3/2016 Chandrasenan ..... D24/111  
 9,468,715 B2 10/2016 Tsoukalis  
 9,581,157 B2 2/2017 Hayes-Pankhurst et al.  
 9,603,995 B2 3/2017 Rosinko et al.  
 9,669,404 B2 6/2017 Ortiz-hernandez  
 9,682,224 B2 6/2017 Downing et al.  
 D791,306 S \* 7/2017 Clemente ..... D24/111  
 9,724,505 B2 8/2017 Williams et al.  
 9,852,263 B2 12/2017 Harr  
 9,872,948 B2 1/2018 Siess  
 D812,760 S \* 3/2018 Herman ..... D24/186  
 9,936,877 B2 4/2018 Kotz et al.  
 10,064,579 B2 9/2018 Condurso et al.  
 10,098,628 B2 10/2018 Fisher  
 D837,388 S \* 1/2019 DaCosta ..... D24/186  
 D853,583 S \* 7/2019 Pizzochero ..... D24/138  
 D856,506 S \* 8/2019 Wu ..... D24/111  
 10,420,709 B2 9/2019 Davis et al.  
 10,426,709 B2 10/2019 Harr  
 10,455,923 B1 10/2019 Domingues et al.  
 10,532,835 B2 1/2020 Chong et al.  
 10,589,014 B2 3/2020 Gassman  
 D886,986 S \* 6/2020 Clemente ..... D24/111  
 D890,914 S \* 7/2020 Ghodsi ..... D15/7  
 10,813,845 B1 10/2020 Juras  
 D908,863 S \* 1/2021 Kolenda ..... D24/111  
 D917,704 S \* 4/2021 Al-Ali ..... D24/186  
 10,973,739 B2 4/2021 Elia et al.  
 11,020,322 B2 6/2021 Elia et al.  
 11,033,458 B2 6/2021 Shirotni et al.  
 D924,390 S \* 7/2021 Kolenda ..... D24/111  
 D946,749 S \* 3/2022 Smith ..... D24/111  
 D963,158 S \* 9/2022 Gibson ..... D24/111  
 D965,139 S \* 9/2022 Gibson ..... D24/111  
 D971,266 S \* 11/2022 Solana ..... D15/7  
 D986,927 S \* 5/2023 Solana ..... D15/7  
 2004/0007590 A1 1/2004 Hedington et al.  
 2004/0024363 A1 2/2004 Goldberg  
 2005/0135942 A1 6/2005 Wood et al.  
 2005/0177395 A1 8/2005 Blomquist  
 2005/0224534 A1 10/2005 Hudson et al.  
 2006/0062672 A1 3/2006 McBride et al.  
 2008/0095645 A1 4/2008 Tam

2008/0103591 A1 5/2008 Siess  
 2010/0276448 A1 11/2010 Moretti  
 2010/0282807 A1 11/2010 Sisk et al.  
 2012/0016295 A1 1/2012 Tsoukalis  
 2012/0040797 A1 2/2012 Fox  
 2012/0197192 A1 8/2012 Bagwell et al.  
 2012/0289895 A1 11/2012 Tsoukalis  
 2012/0289916 A1 11/2012 Johansson et al.  
 2015/0112264 A1 4/2015 Kamen et al.  
 2016/0030227 A1 2/2016 Bronnimann et al.  
 2016/0346169 A1 12/2016 Sacchetti et al.  
 2018/0078195 A1 3/2018 Sutaria et al.  
 2018/0147123 A1 5/2018 Sacchetti et al.  
 2019/0048871 A1 2/2019 Hayes-Pankhurst et al.  
 2019/0167531 A1 6/2019 Besser et al.  
 2019/0216688 A1 7/2019 Ganter et al.  
 2019/0282757 A1 9/2019 Gylland et al.  
 2019/0314249 A1 10/2019 Thompson et al.  
 2020/0060943 A1 2/2020 Elia et al.  
 2020/0079576 A1 3/2020 Thompson et al.  
 2020/0222286 A1 7/2020 Elia et al.  
 2020/0281819 A1 9/2020 Elia et al.  
 2021/0015517 A1 1/2021 Root et al.  
 2021/0037829 A1 2/2021 Gupta et al.  
 2022/0087904 A1 \* 3/2022 Piper ..... A61J 15/0053  
 2023/0191023 A1 \* 6/2023 Piper ..... A61M 5/1723  
 604/503  
 2024/0108819 A1 \* 4/2024 Kamen ..... A61M 5/5086

FOREIGN PATENT DOCUMENTS

CA 2818220 6/2012  
 CN 107050581 8/2017  
 CN 109223574 1/2019  
 CN 307907179 \* 3/2023  
 CN 307928825 \* 3/2023  
 EP 2258333 12/2010  
 JP 4485556 6/2010  
 JP D1759359 \* 12/2023  
 WO WO 2005/072815 9/2005  
 WO WO 2013/024044 2/2013  
 WO WO 2014/049478 4/2014  
 WO WO 2015/053616 4/2015  
 WO WO 2016/160676 10/2016  
 WO WO 2017/140731 8/2017  
 WO WO 2018/108337 6/2018  
 WO WO 2018/150219 8/2018  
 WO WO 2019/145004 8/2019  
 WO WO 2020/007657 1/2020  
 WO WO 2021/046504 3/2021

OTHER PUBLICATIONS

Daley, Tracy, "Tube-fed patients may be suffering due to the lack of physical activity", 2005, Zevex Inc., 4 pages.  
 Infinity Orange Operator's Manual, Small Volume Enteral Feeding Pump, Zevex Enteral Nutrition Delivery Systems, 2008, 54 pages.

\* cited by examiner

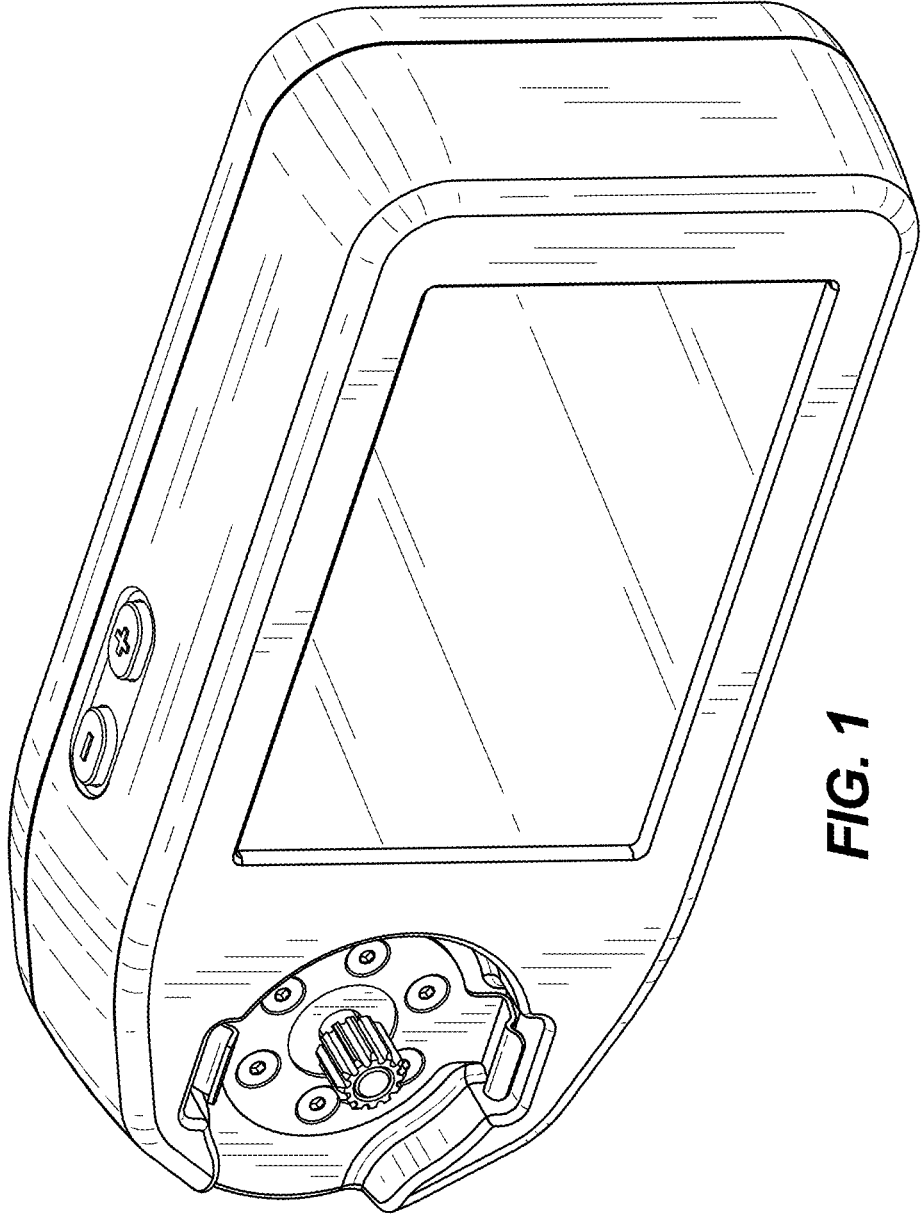

**FIG. 1**

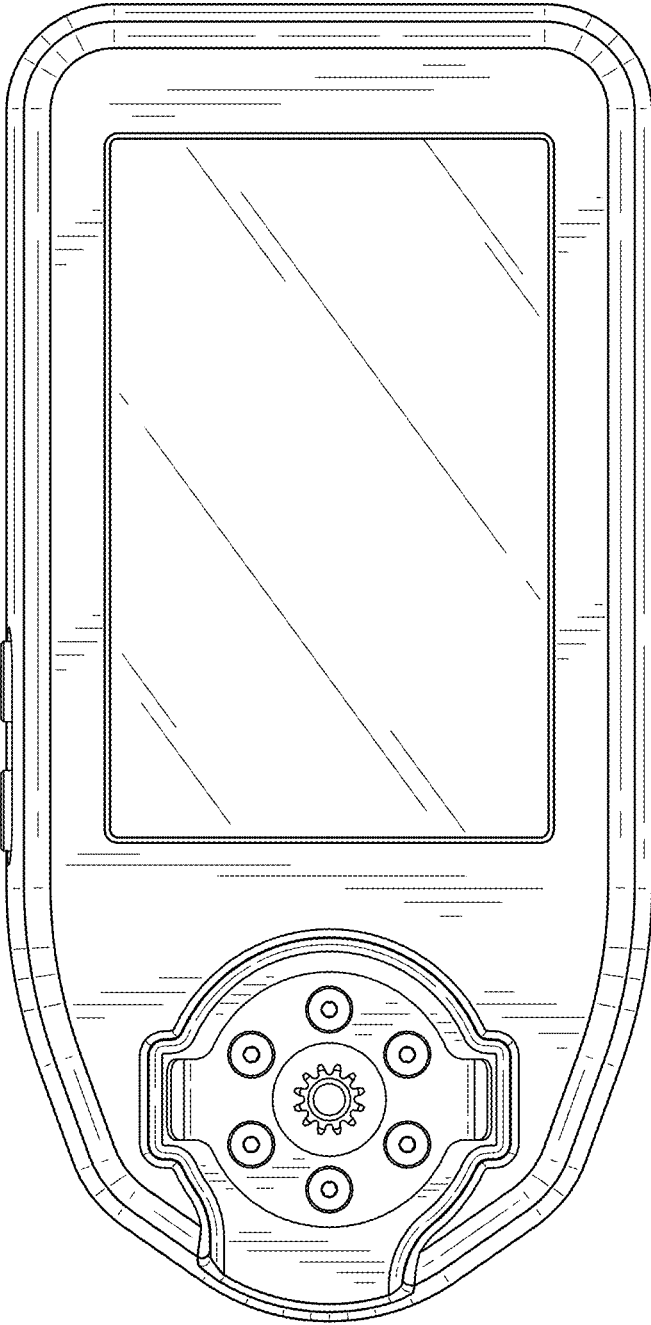

**FIG. 2**

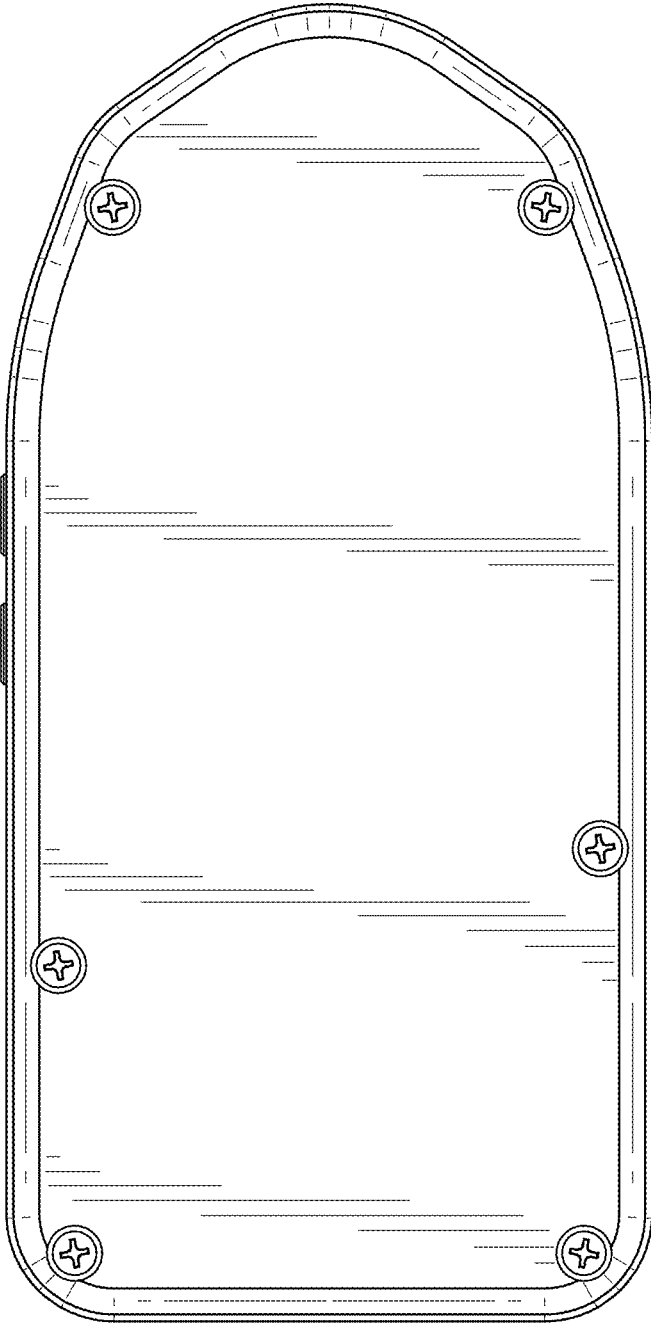

**FIG. 3**

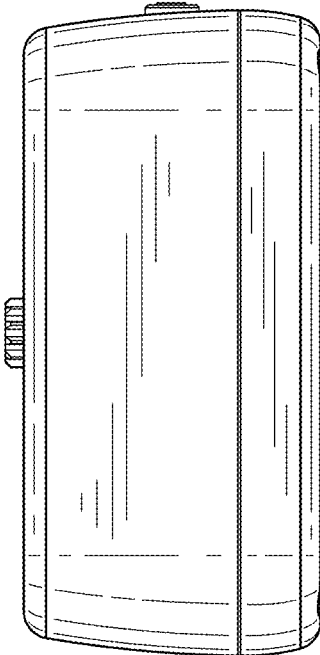

**FIG. 4**

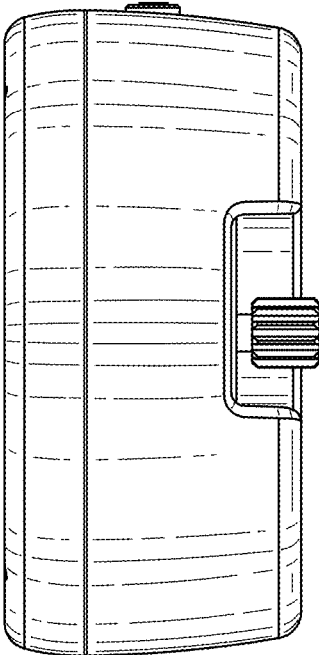

**FIG. 5**

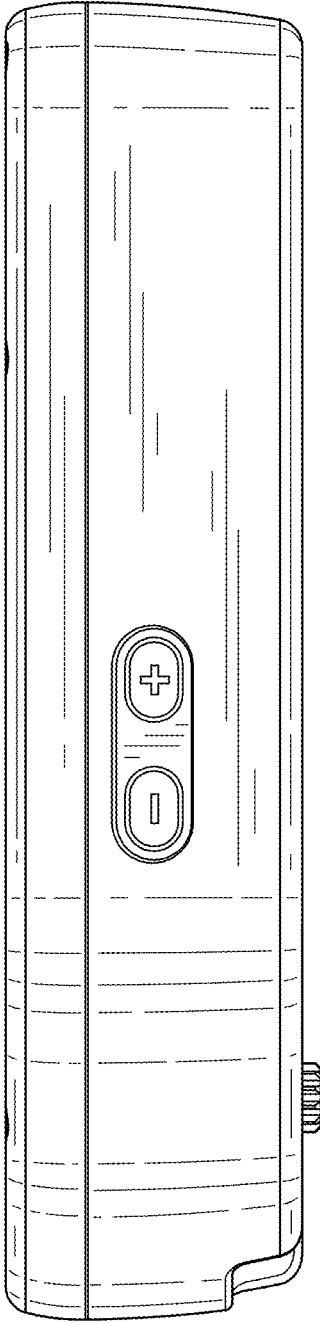

**FIG. 6**

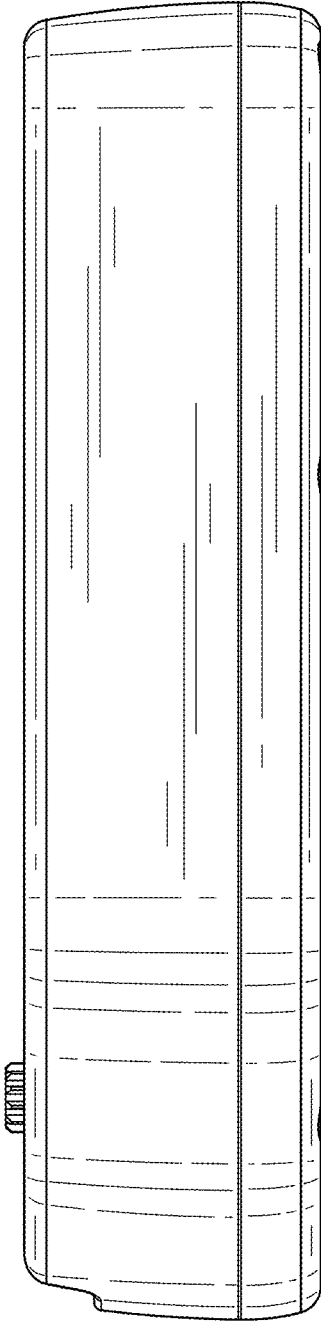

**FIG. 7**