

(19) World Intellectual Property Organization
International Bureau



(43) International Publication Date
20 January 2011 (20.01.2011)

PCT

(10) International Publication Number
WO 2011/008444 A1

(51) International Patent Classification:
A61B 18/14 (2006.01) *A61B 5/042* (2006.01)

(21) International Application Number:
PCT/US2010/039600

(22) International Filing Date:
23 June 2010 (23.06.2010)

(25) Filing Language: English

(26) Publication Language: English

(30) Priority Data:
61/221,967 30 June 2009 (30.06.2009) US
61/325,456 19 April 2010 (19.04.2010) US

(71) Applicant (for all designated States except US):
BOSTON SCIENTIFIC SCIMED, INC. [US/US]; One Scimed Place, Maple Grove, Minnesota 55311-1566 (US).

(72) Inventors; and

(75) Inventors/Applicants (for US only): **KIM, Isaac** [US/US]; 3268 Montecito Dr., San Jose, California 95135 (US). **KOBLISH, Josef** [US/US]; 1568 Partridge Ct., Sunnyvale, California 94087 (US). **VELILLA, Simplicio** [US/US]; 3414 Laguna Ct., Santa Clara, California 95051 (US). **MIRIGIAN, Mark** [US/US]; 31403 Hugh Way, Hayward, California 94544 (US).

(74) Agents: **BEEKMAN, Marvin L.** et al.; SCHWEGMAN, LUNDBERG & WOESSNER P.A., P.O. Box 2938, Minneapolis, Minnesota 55402 (US).

(81) Designated States (unless otherwise indicated, for every kind of national protection available): AE, AG, AL, AM, AO, AT, AU, AZ, BA, BB, BG, BH, BR, BW, BY, BZ, CA, CH, CL, CN, CO, CR, CU, CZ, DE, DK, DM, DO, DZ, EC, EE, EG, ES, FI, GB, GD, GE, GH, GM, GT, HN, HR, HU, ID, IL, IN, IS, JP, KE, KG, KM, KN, KP, KR, KZ, LA, LC, LK, LR, LS, LT, LU, LY, MA, MD, ME, MG, MK, MN, MW, MX, MY, MZ, NA, NG, NI, NO, NZ, OM, PE, PG, PH, PL, PT, RO, RS, RU, SC, SD, SE, SG, SK, SL, SM, ST, SV, SY, TH, TJ, TM, TN, TR, TT, TZ, UA, UG, US, UZ, VC, VN, ZA, ZM, ZW.

(84) Designated States (unless otherwise indicated, for every kind of regional protection available): ARIPO (BW, GH, GM, KE, LR, LS, MW, MZ, NA, SD, SL, SZ, TZ, UG, ZM, ZW), Eurasian (AM, AZ, BY, KG, KZ, MD, RU, TJ, TM), European (AL, AT, BE, BG, CH, CY, CZ, DE, DK, EE, ES, FI, FR, GB, GR, HR, HU, IE, IS, IT, LT, LU, LV, MC, MK, MT, NL, NO, PL, PT, RO, SE, SI, SK, SM, TR), OAPI (BF, BJ, CF, CG, CI, CM, GA, GN, GQ, GW, ML, MR, NE, SN, TD, TG).

Published:

- with international search report (Art. 21(3))
- before the expiration of the time limit for amending the claims and to be republished in the event of receipt of amendments (Rule 48.2(h))

(54) Title: MAP AND ABLATE OPEN IRRIGATED HYBRID CATHETER

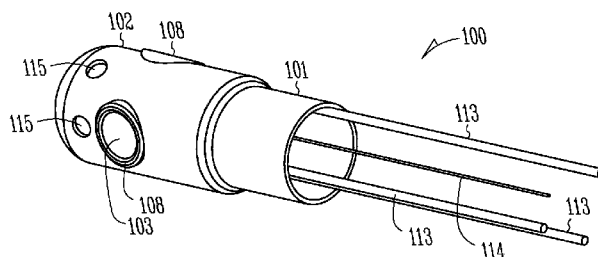

Fig. 1A

(57) Abstract: An embodiment of an open-irrigated catheter system comprises a tip section, a distal insert, and mapping electrodes. The tip section has an exterior wall that defines an open interior region within the tip section. The exterior wall includes mapping electrode openings and irrigation ports. The exterior wall is conductive for delivering radio frequency (RF) energy for an RF ablation procedure. The irrigation ports are in fluid communication with the open interior region to allow fluid to flow from the open interior region through the irrigation ports. The distal insert is positioned within the tip section to separate the open region into a distal fluid reservoir and a proximal fluid reservoir. The mapping electrodes are positioned in the mapping electrode openings in the tip section.



WO 2011/008444 A1

MAP AND ABLATE OPEN IRRIGATED HYBRID CATHETER

5

CLAIM OF PRIORITY

[0001] Benefit of priority is hereby claimed to U.S. Provisional Application No. 61/221,967, filed on June 30, 2009 and U.S. Provisional Application No. 61/325,456, filed on April 19, 2010, which applications are hereby incorporated by reference.

10

TECHNICAL FIELD

[0002] This application relates generally to medical devices and, more particularly, to systems, devices and methods related to open-irrigated hybrid catheters used to perform mapping and ablation functions.

15

BACKGROUND

[0003] Aberrant conductive pathways disrupt the normal path of the heart's electrical impulses. For example, conduction blocks can cause the electrical impulse to degenerate into several circular wavelets that disrupt the normal activation of the atria or ventricles. The aberrant conductive pathways create abnormal, irregular, and sometimes life-threatening heart rhythms called arrhythmias. Ablation is one way of treating arrhythmias and restoring normal contraction. The sources of the aberrant pathways (called focal arrhythmia substrates) are located or mapped using mapping electrodes situated in a desired location. After mapping, the physician may ablate the aberrant tissue. In radio frequency (RF) ablation, RF energy is directed from the ablation electrode through tissue to an electrode to ablate the tissue and form a lesion.

20

25

SUMMARY

[0004] An embodiment of an open-irrigated catheter system comprises a tip section, a distal insert, and mapping electrodes. The tip section has an exterior wall that defines an open interior region within the tip section. The exterior wall includes mapping electrode openings and irrigation ports. The exterior wall is conductive for delivering radio frequency (RF) energy for an RF

30

ablation procedure. The irrigation ports are in fluid communication with the open interior region to allow fluid to flow from the open interior region through the irrigation ports. The distal insert is positioned within the tip section to separate the open region into a distal fluid reservoir and a proximal fluid reservoir. The mapping electrodes are positioned in the mapping electrode openings in the tip section.

5 [0005] A catheter system embodiment comprises a conductive exterior wall with mapping electrode openings, wherein the conductive exterior wall is configured for use in delivering RF energy for ablation functions. The catheter system embodiment may, but need not, be an open-irrigated catheter. The catheter system embodiment includes mapping electrodes positioned in the mapping electrode openings, and noise artifact isolators positioned in the mapping electrode openings. The mapping electrodes are electrically insulated from the exterior wall by the noise artifact isolators.

10 [0006] An electrode assembly embodiment comprises an electrode, an electrode shaft, and a noise artifact isolator. The electrode has a circumference defining sides of the electrode, a first surface, and a second surface opposite the first surface. The electrode shaft extends from the second surface of the electrode, and is in electrical conduction with the electrode. The noise artifact isolator is in contact with the sides of the electrode and surrounds the circumference of the electrode.

15 [0007] A method of forming an open-irrigated catheter tip includes inserting a distal insert into a distal tip section and connecting the distal tip section to a proximally adjacent structure. Inserting the distal insert includes moving the distal insert into the distal tip section until a distal extension of the insert contacts a distal end of the distal tip section to self-position the distal insert proximate to irrigation ports.

20 [0008] This Summary is an overview of some of the teachings of the present application and not intended to be an exclusive or exhaustive treatment of the present subject matter. Further details about the present subject matter are found in the detailed description and appended claims. The scope of the present invention is defined by the appended claims and their equivalents.

BRIEF DESCRIPTION OF THE DRAWINGS

- [0009] Various embodiments are illustrated by way of example in the figures of the accompanying drawings. Such embodiments are demonstrative and not
5 intended to be exhaustive or exclusive embodiments of the present subject matter.
- [0010] FIGS. 1A-1D illustrate an embodiment of a hybrid catheter with distal irrigation ports and three microelectrodes used to perform the mapping function.
- [0011] FIGS. 2A-2D illustrate an embodiment of a hybrid catheter with distal irrigation ports and four microelectrodes used to perform the mapping function.
- 10 [0012] FIGS. 3A-3D illustrate a microelectrode with a noise artifact isolator, according to various embodiments.
- [0013] FIGS. 4A-4C illustrate an embodiment of a hybrid catheter in which the tip body includes separate distal and proximal portions, and where both the distal and proximal portions of the tip body are configured to connect to the distal
15 insert that separates the distal and proximal portions.
- [0014] FIGS. 5A-5D illustrate an embodiment of a map and ablate catheter with distal and proximal irrigation ports.
- [0015] FIGS. 6A-6B illustrate an embodiment of a map and ablate catheter with distal irrigation ports.
- 20 [0016] FIGS. 7A-7B illustrate another embodiment of a map and ablate catheter with distal irrigation ports and a proximal fluid chamber.
- [0017] FIGS. 8A-8C illustrate various distal insert embodiments configured for self-alignment and configured to isolate electrical components from the irrigation fluid.
- 25 [0018] FIGS. 9A-9C illustrate various embodiments for realizing a seal area between the distal inserts and the exterior wall of the electrode tip.
- [0019] FIG. 10 illustrates a section view of a tip electrode assembly embodiment that includes an embodiment of a distal insert.
- [0020] FIG. 11 illustrates an embodiment of a mapping and ablation system
30 that includes an open-irrigated catheter.

DETAILED DESCRIPTION

[0021] The following detailed description of the present invention refers to subject matter in the accompanying drawings which show, by way of illustration, specific aspects and embodiments in which the present subject matter may be practiced. These embodiments are described in sufficient detail to enable those skilled in the art to practice the present subject matter. References to “an,” “one,” or “various” embodiments in this disclosure are not necessarily to the same embodiment, and such references contemplate more than one embodiment. The following detailed description is, therefore, not to be taken in a limiting sense, and the scope is defined only by the appended claims, along with the full scope of legal equivalents to which such claims are entitled.

[0022] This present subject matter generally relates to a radiofrequency (RF) ablation catheter system. The catheter is referred to as a hybrid catheter herein as it can be used simultaneously for both localized mapping and ablation functions. The hybrid catheter is configured to provide localized, high resolution ECG signals during ablation. The localized mapping enables the mapping to be more precise than that which can be achieved with conventional ablation catheters. The hybrid catheter has an open-irrigated catheter design. A cooling fluid, such as a saline, is delivered through the catheter to the catheter tip, where the fluid exits through irrigation ports to cool the electrode and surrounding tissue. Clinical benefits of such a catheter include, but are not limited to, controlling the temperature and reducing coagulum formation on the tip of the catheter, preventing impedance rise of tissue in contact with the catheter tip, and maximizing potential energy transfer to the tissue. Additionally, the localized intra cardiac electrical activity can be recorded in real time or near-real time right at the point of energy delivery.

[0023] FIGS. 1A-1D illustrate an embodiment of a hybrid catheter with distal irrigation ports and three microelectrodes used to perform the mapping function. The illustrated catheter 100 includes a catheter tip body 101, an open-irrigated tip section 102 used to perform mapping and ablation functions, and mapping electrodes 103. With reference to FIG. 1B, the illustrated embodiment includes a generally hollow tip body and a distal insert 104 disposed therein and configured to separate a proximal fluid reservoir 105 and distal fluid reservoir

106. The hollow tip body has an open interior region defined by an exterior wall of the tip section. Fluid flow through these reservoirs is used to provide targeted cooling of portions of the tip electrode. In the illustrated embodiment, the hollow tip body has a generally cylindrical shape. By way of an example and not limitation, an embodiment of tip body has a diameter on the order of about 5 0.08-0.1 inches, has a length on the order of about .2-.3 inches, and has an exterior wall with a thickness on the order of 0.003-0.004 inches.

[0024] The illustrated distal insert 104 includes openings or apertures 107 sized to receive a microelectrode and its corresponding noise artifact isolator 108. These microelectrodes used in the mapping function to image localized intra cardiac activity. The device may be used to record high resolution, precise localized electrical activity, to prevent excessive heating of the ablation electrode, to allow greater delivery of power, to prevent the formation of coagulum and to provide the ability to diagnose complex ECG activity. The 10 illustrated distal insert 104 also includes a fluid conduit or passage 109 to permit fluid to flow for the proximal fluid reservoir 105 to the distal fluid reservoir 106, a thermocouple opening 110 sized to receive a thermocouple 111, and openings 112 sized to receive electrical conductors 113 used to provide electrical connections to the microelectrodes 103. Also illustrated is a thermocouple wire 15 114 connected to the thermocouple 111. By way of example and not limitation, an embodiment of the distal insert is fabricated from stainless steel.

[0025] The tip section 102 is formed from a conductive material. For example, some embodiments use a platinum-iridium alloy. Some embodiments use an alloy with approximately 90% platinum and 10% iridium. This 25 conductive material is used to conduct RF energy used to form lesions during the ablation procedure. A plurality of irrigation ports 115 or exit ports are shown near the distal end of the tip section 102. By way of example and not limitation, an embodiment has irrigation ports with a diameter approximately within a range of 0.01 to 0.02 inches. Fluid, such as a saline solution, flows from the distal 30 fluid reservoir 106, through these ports 115, to the exterior of the catheter. This fluid is used to cool the ablation electrode tip and the tissue near the electrode. This temperature control reduces coagulum formation on the tip of the catheter,

prevents impedance rise of tissue in contact with the catheter tip, and increases energy transfer to the tissue because of the lower tissue impedance.

[0026] FIGS. 1A-1D illustrate a three microelectrode embodiment in which the three microelectrodes are used to perform mapping functions. However, the hybrid catheter may include other numbers of microelectrodes. For example, 5 FIGS. 2A-2D illustrate an embodiment of a hybrid catheter with distal irrigation ports and four microelectrodes used to perform the mapping function.

[0027] The illustrated catheter 200 includes a catheter tip body 201, an open-irrigated tip section 202 used to perform mapping and ablation functions, and 10 microelectrodes 203. With reference to FIG. 1B, the illustrated embodiment includes a generally hollow tip body and a distal insert 204 disposed therein and configured to separate a proximal fluid reservoir 205 and distal fluid reservoir 206. The illustrated distal insert 204 includes openings or apertures 207 sized to receive a microelectrode and its corresponding noise artifact isolator 208. The 15 illustrated distal insert 204 also includes a fluid conduit or passage 209 to permit fluid to flow from the proximal fluid reservoir 205 to the distal fluid reservoir 206, a thermocouple opening 210 sized to receive a thermocouple 211, and openings 212 sized to receive electrical conductors 213 used to provide electrical connections to the microelectrodes 203. Also illustrated is a thermocouple wire 20 214 connected to the thermocouple 211.

[0028] FIGS. 3A-3D illustrate a microelectrode with a noise artifact isolator, according to various embodiments. The illustrated microelectrode 303 is surrounded by the noise artifact isolator 308. An electrode shaft 315 is connected to the electrode 303, and provides an electrical connection between 25 the electrode and the electrical conductors. The microelectrodes are small, independent diagnostic sensing electrodes embedded within the walls of the ablation tip of the RF ablation catheter. The noise artifact isolator electrically isolates the small electrodes from the conductive walls of the ablation tip. According to various embodiments, the noise artifact isolator is a polymer-based 30 material sleeve and/or adhesive that encapsulates the microelectrodes. The isolator has a lip 316 over the outside edge of the microelectrode circumference that blocks the RF pathway into the surface of the microelectrodes. According to various embodiments, the lip extends a distance within a range of

approximately 0.002 to 0.020 inches past the surface of the electrode. According to various embodiments, the lip extends a distance of approximately 0.003 inches around the circumference of the microelectrode. The isolator isolates the noise entrance creating a much cleaner electrogram during an RF ablation mode.

5 An in-vitro test result provides evidence that the illustrated isolator significantly reduce the noise artifact during RF. These electrically-isolated microelectrodes are able to sense highly localized electrical activity, avoid a far field component, and simultaneously achieve the ability to ablate tissue without noise artifact during RF mode.

10 **[0029]** FIGS. 4A-4C illustrate an embodiment of a hybrid catheter in which the tip body includes separate distal and proximal portions, and where both the distal and proximal portions of the tip body are configured to connect to the distal insert that separates the distal and proximal portions. The embodiment illustrated in FIGS. 4A-4C provides a design to simplify manufacturing of the
15 open-irrigated, mapping and ablation catheter. The illustrated device has a distal and proximal chamber separated into proximal 417 and distal tip sections 418. These sections are separated by the distal insert 419, which accommodates microelectrodes 420, a cooling flow channel 421, and a thermocouple slot 422. The illustrated distal insert 419 includes openings or apertures 424 sized to
20 receive a microelectrode and its corresponding noise artifact isolator 423, and openings 424 sized to receive electrical conductors 425 used to provide electrical connections to the microelectrodes 420. The distal tip has distal holes or irrigations ports 415 around the proximal edge of the domed section of the tip.

[0030] The illustrated distal insert has ends with lip edges 426. Both the
25 distal and proximal tip sections 418 and 417 are designed to fit over the lip edges of the distal insert ends. A middle portion of the distal insert, between the proximal and distal lips, has an outer surface substantially flush with an outer surface of the distal and proximal tip sections. In some embodiments, the distal and proximal tips sections are bonded to the distal insert. The bonding process
30 may involve a swaging/mechanical locking method, precise laser welding, force press fit, soldering and other means of chemical/mechanical bonding. The separate tip design provides a simple assembly process to bond the thermocouple and simplifies cleaning of the device. FIG. 4B also illustrates a thermocouple.

Thus, according to a method for forming an open-irrigated catheter tip, a distal lip of a distal insert is inserted in a proximal end of the distal tip section.

Mapping electrodes are seated in mapping openings around a circumference of the distal insert. A distal end of a proximal tip section is inserted over a proximal lip of the distal insert. A bonding process is performed to bond the distal and proximal tip sections to the distal insert.

5 [0031] FIGS. 5A-5C illustrate an embodiment of a map and ablate catheter with distal and proximal irrigation ports. The illustrated embodiment provides an open-irrigation RF ablation catheter with mapping and ablation functions in a Blazer tip platform. The Blazer tip is a tip developed by Boston Scientific. The relatively large surface area of the Blazer tip allows more power to be delivered, which allows a larger lesion to be made. The larger surface area also promotes increased passive cooling by blood over the electrode.

10 [0032] The illustrated catheter has a tip section 526 with distal fluid ports 527, and proximal fluid ports 528. The distal insert 529 is made of plastic components such as Ultem inside the tip which is designed to separate a proximal reservoir 530 and a distal reservoir 531 for targeted cooling portions of the tip electrode, provide openings for the cooling fluid and the thermocouple, and provide housing for the microelectrodes 532 to image real time localized intra cardiac activity. The ends of this distal insert are encapsulated with adhesives to completely isolate distal tip chamber from proximal tip chamber.

20 [0033] The cooling lumen 533 is designed to cool the proximal/distal chamber while insulating the microelectrode lead wire junction from cooling fluid. The cooling lumen 533 includes several micro holes 534 in the proximal area of the tip to allow fluid to pass through these micro holes 534 and through the distal end of the cooling lumen, cooling the proximal tip and ultimately exiting through the proximal tip holes 528. The cooling lumen and tip ports can be configured in different modes to optimize cooling efficiency for both distal and proximal chamber. For example, different diameter sizes and orientations can be implemented to adjust cooling.

30 [0034] Some embodiments include a three microelectrode configuration and some embodiments include a four microelectrode configuration. FIG. 5C illustrates a distal insert 529 for a four microelectrode configuration. The

illustrated insert 529 has openings 536 through which an electrical connection can be made with the microelectrodes 532. The tip size is within a range of approximately 4-10 mm, for example. Some embodiments do not include a proximal cooling chamber. The microelectrodes 532, which are used in the mapping function, are isolated from the conductive tip used to perform the ablation using a noise artifact isolator 535.

[0035] FIG. 5D illustrates an embodiment of the present subject matter incorporated into a Blazer tip. The illustrated embodiment includes a catheter body 537 and a tip section 526, and includes a plurality of ring electrodes 538, the microelectrodes 532, distal fluid ports 527 and proximal fluid ports 528.

[0036] FIGS. 6A-6B illustrate an embodiment of a map and ablate catheter with distal irrigation ports 627. The cooling lumen 633 includes micro holes 634 to pass fluid in a proximal reservoir to cool the proximal portion of the tip. This fluid passes into the distal reservoir out through the distal fluid ports 627.

[0037] Some embodiments shorten the cooling lumen up to the proximal end of the distal insert, allowing the fluid to cool the proximal end of the chamber before passing the distal tip chamber and ultimately passing thru the distal tip holes. FIGS. 7A-7B illustrate an example of a map and ablate catheter with distal irrigation ports 727 and a proximal fluid chamber, where fluid exits a cooling lumen into a proximal reservoir 730 before passing into the distal reservoir 731 and exiting the distal irrigation ports 727.

[0038] Electrical signals, such as electrocardiograms (ECGs), are used during a cardiac ablation procedure to distinguish viable tissue from not viable tissue. If ECG amplitudes are seen to attenuate during the delivery of RF energy into the tissue, the delivery of RF energy into that specific tissue may be stopped. However, noise on the ECG signals makes it difficult to view attenuation. It is currently believed that internal cooling fluid circulation, cooling fluid circulating externally in contact with other electrodes, and/or fluid seepage in between the electrodes and their housing may cause the noise on this type of ablation catheter.

[0039] Various embodiments, as described below, isolate the microelectrode signal wires from the cooling fluid circulating in the proximal chamber of the hollow ablation electrode, and thus are expected to reduce the noise that is

contributed from the internal cooling fluid circulation. The fluid seal can be provided without bonding or adhesive. The electrical components within the tip are isolated from the cooling flow of irrigation fluid while the irrigation fluid maintains internal cooling of the proximal and distal portions of the tip electrode.

5 Further, as provided in more detail below, these designs have the potential of increasing the accuracy of the temperature readings from the thermocouple.

[0040] Various distal insert embodiments include design elements configured for self-positioning the distal insert during manufacturing. These embodiments reduce the number of processing steps to join the distal insert to
10 the tip electrode.

[0041] FIGS. 8A-8C illustrate various distal insert embodiments configured for self-alignment and configured to isolate electrical components from the irrigation fluid. Some embodiments are configured for self-alignment, some
15 embodiments are configured to isolate electrical components from the irrigation fluid, and some embodiments as illustrated are configured for both self-alignment and for isolating electrical components from the irrigation fluid. FIG. 8A illustrates a distal insert embodiment with fluid channels formed in a peripheral surface of the insert, FIG. 8B illustrates a distal insert embodiment with fluid
20 lumens formed through the distal insert, and FIG. 8C illustrates a section view of the distal insert embodiment of FIG. 8A.

[0042] The illustrated distal inserts 832A and 832B include a distally-
extending member 833. The distal insert includes a main body portion 834A and
834B and a channel 835 extending from a proximal channel end 836 through the
main body portion to a distal channel end 837. The main body portion 834A and
25 834B has a circumference or outer diameter generally complementary to an
inside diameter of the exterior wall of the tip section, and has a peripheral
surface with openings 838 therein sized to receive the electrodes. The exterior
wall of the tip section also has mapping electrode apertures. During assembly,
the apertures in the exterior wall and the apertures in the distal insert are aligned,
30 and the mapping electrodes are positioned and potted within the apertures. The
channel has an interior passage that is isolated from the proximal fluid reservoir.
Mapping electrode wires extend through the interior passage of the channel into

smaller channels 839 in the main body portion of the distal insert to the mapping electrodes.

[0043] The distal insert embodiments illustrated in FIGS. 8A-8C include a circumferential groove 840, on which an o-ring is seated to form a seal between the distal insert and the exterior wall of the hollow electrode to prevent fluid from seeping around the side of the distal insert. This seal, generally illustrated in FIG. 8C as a seal area, prevents fluid from seeping between the distal insert and the exterior wall of the tip section, and between the electrodes and their housing.

[0044] FIGS. 9A-9C illustrate various embodiments for realizing a seal area between the distal inserts and the exterior wall of the electrode tip. FIG. 9A generally illustrates the groove 940 and o-ring 941, such as was generally illustrated in FIGS. 8A-8C. Other embodiments include annular or circumferential detents 942 formed as part of the main body and configured to extend away from the peripheral surface of the main body, as generally illustrated in FIG. 9B. These detents engage the interior surface of the exterior wall of the tip section, thus securing the distal insert within the tip section. Some embodiments, as generally illustrated in FIG. 9C, form the peripheral surface with a circumferential gasket 943 configured to provide a seal between the distal insert and the exterior wall. The gasket 943 may be formed from a flexible material such as a polymer. These embodiments for realizing a seal are not intended to be an exclusive list, as other seals may be used to seal the fluid from the mapping electrodes.

[0045] FIG. 10 illustrates a section view of a tip electrode assembly embodiment 1044 that includes an embodiment of a distal insert 1032. The distal insert partitions a hollow ablation electrode into a proximal chamber 1045 and a distal chamber 1046, thus allowing cooling of the proximal chamber 1045. The cooling of the proximal chamber 1045 mitigates heating known as "edge effect" before the fluid is directed into the distal chamber 1046 and discharged through irrigation ports into the vasculature. The distal insert houses multiple, smaller electrodes in apertures 1038 in the tip electrode to provide localized electrical information.

[0046] The illustrated embodiment simplifies and improves the consistency of the method for positioning the insert into the hollow tip electrode. The distal insert 1032 is inserted into the hollow tip electrode 1044 and is automatically located within the electrode due to the distally-extending member 1033 of the isolation channel. The outer diameter of the insert and the o-ring are designed such that no additional adhesive is necessary to form a seal between the tip and the distal insert. The proximal section 1047 of the isolation channel terminates in a slot of the adjacent component 1048 that is potted with adhesive.

[0047] The exterior wall of the tip section has a distal end 1049 separated from the irrigation ports 1050 of the electrode by a predetermined distance 1051, and the distally-extending member is configured with a predetermined length 1052 to position the distal insert in the tip section on a proximal side of the irrigation ports 1050 when the distal channel end abuts the distal end of the exterior wall of the electrode.

[0048] When the apparatus is inserted into a hollow tip electrode in the direction illustrated by arrow 1053, the distal section of the isolated channel has a length that positions the distal edge of the insert above or proximal to the irrigation ports, allowing the irrigation ports provide fluid communication between the distal chamber and the exterior of the ablation electrode.

[0049] The overall diameter of the apparatus is similar enough to the inside diameter of the tip electrode that an o-ring placed in the circumferential groove provides an adequate seal forcing cooling fluid to flow through the fluid channels 1054, also illustrated in FIG. 8A at 854. Because of the design characteristics, manufacturing processes are reduced.

[0050] The channel houses the thermocouple and signal wires from the microelectrodes. The proximal end of the insulated channel terminates in the adjacent structure within the tip, which is potted with epoxy and isolated from the cooling fluid. The thermocouple is in contact with the distal end of the electrode tip. Some embodiments provide slots 1055 at the distal channel end of the channel allowing cooling fluid to circulate into contact with the thermocouple. Some embodiments do not include slots, but rather provide a fluid-tight seal between the channel and the distal end of the electrode tip, such that the fluid does not circulate into contact with the thermocouple.

[0051] RF generators are configured with a cut-off temperature, where the RF ablation energy is cut off if the temperature reaches a particular level. However, some RF generators are configured with a relatively low cut-off temperature that reflects a less-than-accurate temperature measurement. The slots 1055 are believed to allow the embodiments of the present subject matter to operate with such devices. Various embodiments provide four slots. Other embodiments include other numbers of slots. Embodiments that include a slotted channel seal the channel at a more proximate position to prevent fluid from traveling through the channel toward the wiring. Some embodiments do not include slots, but rather seal the distal channel end to the distal wall of the electrode to prevent fluid from contacting the thermocouple. Such embodiments that isolate the thermocouple are believed to provide more accurate temperature measurements.

[0052] The distal insert includes fluid paths from the proximal chamber to the distal chamber to create a back pressure as fluid enters the proximal chamber, causing the fluid to circulate before being forced through the channels into the distal chamber. According to various embodiments, the fluid paths have an equal cross-sectional area and equally positioned around the center of the distal insert. Various embodiments include three equally-spaced fluid paths. In some embodiments, the fluid paths are fluid channels 856 formed in a peripheral surface 857 of the main body of the distal insert. The fluid channels provide the fluid pathways toward the exterior of the distal insert, thus allowing the insert to seat more electrodes around its circumference. In some embodiments, the fluid paths are lumens 858 formed through the main body of the distal insert. The lumens 858 provide further isolation of the mapping electrodes from the fluid, as the fluid flowing through the lumens is not in contact with the interface between the peripheral surface of the insert and the inner surface of the exterior wall of the electrode.

[0053] Wire channel branches, illustrated at 839 in FIG. 8C and at 1039 in FIG. 10, allow the signal wires from the microelectrodes to enter the isolated channel. The illustrated embodiment is designed with three equally-spaced microelectrodes. Thus, the distal electrode embodiment includes three wire channels extending from an electrode aperture in the distal insert to the wire

channel. According to various embodiments, these channel branches are angled (e.g. 15 to 60 degrees) to aid wire threading. This entire section is potted with adhesive to isolate this section from any potential cooling fluid.

[0054] FIG. 10 also generally illustrates a method for forming an open-irrigated catheter tip. A distal insert 1032 is inserted into a distal tip section or hollow electrode 1044. The distal insert includes a distal extension and the distal tip section includes a distal end and irrigation ports separated from the distal end by a predetermined distance. Inserting the distal insert includes moving the distal insert into the distal tip section until the distal extension contacts the distal end of the distal tip section to self-position the distal insert proximate to the irrigation portions. The distal tip section is connected to a proximally adjacent structure. For example, some embodiments swage the distal tip section to join the distal tip section against the proximally adjacent structure 1044. The distal insert partitions the distal tip section into a distal fluid reservoir between the distal insert and the distal end, and a proximal fluid reservoir between the distal insert and the proximally adjacent structure. The distal insert provides fluid communication between the distal and proximal fluid reservoirs. In various embodiments, inserting the distal insert into the distal tip section includes aligning mapping electrode apertures in the distal insert with mapping electrode apertures in the distal tip section. The mapping electrodes are seated into the mapping electrode apertures. Wires connected to the mapping electrodes run through the channel of the distal insert.

[0055] FIG. 11 illustrates an embodiment of a mapping and ablation system 1156 that includes an open-irrigated catheter. The illustrated catheter includes an ablation tip 1157 with mapping microelectrodes 1158 and with irrigation ports 1159. The catheter can be functionally divided into four regions: the operative distal probe assembly region (e.g. the distal portion of catheter body 1160), a main catheter region 1161, a deflectable catheter region 1162, and a proximal catheter handle region where a handle assembly 1163 including a handle is attached. A body of the catheter includes a cooling fluid lumen and may include other tubular element(s) to provide the desired functionality to the catheter. The addition of metal in the form of a braided mesh layer sandwiched

in between layers of plastic tubing may be used to increase the rotational stiffness of the catheter.

[0056] The deflectable catheter region 1162 allows the catheter to be steered through the vasculature of the patient and allows the probe assembly to be accurately placed adjacent the targeted tissue region. A steering wire (not shown) may be slidably disposed within the catheter body. The handle assembly may include a steering member such as a rotating steering knob that is rotatably mounted to the handle. Rotational movement of the steering knob relative to the handle in a first direction may cause a steering wire to move proximally relative to the catheter body which, in turn, tensions the steering wire, thus pulling and bending the catheter deflectable region into an arc; and rotational movement of the steering knob relative to the handle in a second direction may cause the steering wire to move distally relative to the catheter body which, in turn, relaxes the steering wire, thus allowing the catheter to return toward its form. To assist in the deflection of the catheter, the deflectable catheter region may be made of a lower durometer plastic than the main catheter region.

[0057] The illustrated system 1156 includes an RF generator 1164 used to generate the energy for the ablation procedure. The RF generator 1164 includes a source 1165 for the RF energy and a controller 1166 for controlling the timing and the level of the RF energy delivered through the tip 1157. The illustrated system 1156 also includes a fluid reservoir and pump 1167 for pumping cooling fluid, such as a saline, through the catheter and out through the irrigation ports 1159. A mapping signal processor 1168 is connected to the electrodes 1158, also referred to herein as microelectrodes. The mapping signal processor 1168 and electrodes 1158 detect electrical activity of the heart. This electrical activity is evaluated to analyze an arrhythmia and to determine where to deliver the ablation energy as a therapy for the arrhythmia. One of ordinary skill in the art will understand that, the modules and other circuitry shown and described herein can be implemented using software, hardware, and/or firmware. Various disclosed methods may be implemented as a set of instructions contained on a computer-accessible medium capable of directing a processor to perform the respective method.

[0058] This application is intended to cover adaptations or variations of the present subject matter. It is to be understood that the above description is intended to be illustrative, and not restrictive. The scope of the present subject matter should be determined with reference to the appended claims, along with
5 the full scope of legal equivalents to which such claims are entitled.

What is claimed is:

1. An open-irrigated catheter system for performing mapping and ablation functions, comprising:
 - 5 a tip section having an exterior wall that defines an open interior region within the tip section, wherein the exterior wall includes mapping electrode openings and irrigation ports, and wherein the exterior wall is conductive for delivering radio frequency (RF) energy for an RF ablation procedure, wherein the irrigation ports are in fluid communication with the open interior region to
10 allow fluid to flow from the open interior region through the irrigation ports;
a distal insert positioned within the tip section to separate the open region into a distal fluid reservoir and a proximal fluid reservoir; and
mapping electrodes positioned in the mapping electrode openings in the
tip section.
15
2. The system of claim 1, wherein the distal insert has a peripheral surface with openings therein sized to receive the mapping electrodes.
3. The system of claim 1, further comprising a thermocouple, wherein the
20 distal insert defines a thermocouple opening extending from the distal fluid reservoir to the proximal fluid reservoir, the thermocouple opening configured to receive the thermocouple.
4. The system of claim 1, wherein the distal insert defines a fluid conduit
25 extending from the distal fluid reservoir to the proximal fluid reservoir.
5. The system of claim 1, further comprising noise artifact isolators fabricated from an electrical insulator, wherein the mapping electrodes are electrically insulated from the exterior wall of the tip section by the noise artifact
30 isolators.
6. The system of claim 5, wherein the noise artifact isolators have a lip extending out from the exterior wall of the tip section.

7. The system of claim 5, wherein the noise artifact isolators have a generally annular shape.
8. The system of claim 1, wherein the mapping electrodes include three mapping electrodes approximately equally spaced from each other about a circumference of the tip section.
9. The system of claim 1, wherein the mapping electrodes include four mapping electrodes approximately equally spaced from each other spaced about a circumference of the tip section.
10. The system of claim 1, wherein the irrigation ports in fluid communication with the open region include distal irrigation ports in fluid communication with the distal fluid reservoir.
11. The system of claim 1, wherein the irrigation ports in fluid communication with the open region include proximal irrigation ports in fluid communication with the proximal fluid reservoir.
12. The system of claim 1, wherein the irrigation ports in fluid communication with the open region include both distal irrigation ports in fluid communication with the distal fluid reservoir and proximal irrigation ports in fluid communication with the proximal fluid reservoir.
13. The system of claim 1, further comprising a fluid cooling lumen extending through the distal insert to deliver fluid to the distal fluid reservoir, the fluid cooling lumen having a wall with openings therein to deliver fluid to the proximal fluid reservoir.
14. The system of claim 1, wherein:
the tip section includes a proximal section and a distal section, the proximal section including a distal side, and the distal section including a proximal side;

the distal insert includes a proximal lip on a proximal end of the distal insert and a distal lip on a distal end of the distal insert;

the proximal side of the distal section fits over the distal lip; and

the distal side of the proximal section fits over the proximal lip.

5

15. The system of claim 14, wherein the distal insert includes a middle portion between the proximal and distal lips, the middle portion having an outer surface substantially flush with an outer surface of the proximal section and with an outer surface of the distal section.

10

16. The system of claim 1, wherein:

the exterior wall of the tip section has a distal end separated from the irrigation ports by a predetermined distance; and

the distal insert includes a distally-extending member terminating in a distal channel end, wherein the distally extending member is configured with a first predetermined length to position the distal insert in the tip section on a proximal side of the irrigation ports when the distal channel end abuts the distal end of the exterior wall.

20 17. The system of claim 1, wherein:

the exterior wall of the tip section has a distal end separated from the irrigation ports by a predetermined distance;

the distal insert includes a main body portion and a channel extending from a proximal channel end through the main body portion to a distal channel end;

25

the main body portion has a circumference generally complementary to an inside diameter of the exterior wall, and has a peripheral surface with an opening therein sized to receive the mapping electrodes;

the distal channel end abuts the distal wall of the tip section, the main body is positioned on a proximal side of the irrigation ports, and the proximal channel end is connected to a proximally adjacent structure;

the channel has an interior passage that is isolated from the proximal fluid reservoir; and

30

the system includes wires extending through the interior passage of the channel into the main body portion of the distal insert to the mapping electrodes.

18. The system of claim 17, wherein the peripheral surface of the main body
5 has a circumferential groove configured to receive an o-ring gasket for providing a seal between the distal insert and the exterior wall.

19. The system of claim 17, wherein the main body portion includes a
10 circumferential detent extending away from the peripheral surface, wherein the circumferential detent is configured to provide a seal between the distal insert and the exterior wall.

20. The system of claim 17, wherein the main body portion includes a
15 circumferential gasket formed on the peripheral surface, wherein the circumferential gasket is configured to provide a seal between the distal insert and the exterior wall.

21. The system of claim 17, wherein the main body portion has at least three
20 fluid passages, each fluid passage providing fluid communication between the proximal fluid reservoir and the distal fluid reservoir.

22. The system of claim 21, wherein the fluid passages include channels in
the peripheral surface of the main body portion.

25 23. The system of claim 21, wherein the fluid passages include fluid lumens in the peripheral surface of the main body portion.

24. The system of claim 17, further comprising a thermocouple extending
30 through the channel into contact with the distal end of the exterior wall, wherein the thermocouple is isolated from fluid in the distal fluid reservoir.

25. The system of claim 17, further comprising a thermocouple extending
through the channel into contact with the distal end of the exterior wall, wherein

the distal channel end is configured to allow fluid from the distal fluid reservoir to contact the thermocouple.

26. The system of claim 1, further comprising:

- 5 an RF generator operably connected to the exterior wall of the tip section and configured to ablate tissue using the exterior wall of the tip section;
a fluid reservoir and pump, and a lumen extending from the fluid reservoir and pump to the tip section; and
a mapping signal processor operably connected to the mapping electrodes
10 in the tip section to map electrical activity.

27. An open-irrigated catheter system for performing mapping and ablation functions, comprising:

- a tip section having an exterior wall that defines an open interior region
15 within the tip section, wherein the exterior wall includes at least three mapping electrode openings and a plurality of irrigation ports, and wherein the exterior wall is conductive for delivering radio frequency (RF) energy for an RF ablation procedure, wherein the irrigation ports are in fluid communication with the open interior region to allow fluid to flow from the open interior region through the
20 irrigation ports;

a distal insert positioned within the tip section to separate the open region into a distal fluid reservoir and a proximal fluid reservoir, distal insert defining a fluid conduit extending from the distal fluid reservoir to the proximal fluid reservoir;

- 25 at least three mapping electrodes positioned in the at least three mapping electrode openings, the distal insert having a peripheral surface with openings therein sized to receive the mapping electrodes; and

at least three noise artifact isolators fabricated from an electrical insulator, wherein the mapping electrodes are electrically insulated from the
30 exterior wall of the tip section by the noise artifact isolators.

28. The system of claim 27, wherein the noise artifact isolators have a lip extending out from the exterior wall of the tip section.

29. The system of claim 27, wherein the irrigation ports in fluid communication with the open region include distal irrigation ports in fluid communication with the distal fluid reservoir.
- 5 30. The system of claim 29, wherein the irrigation ports in fluid communication with the open region further include proximal irrigation ports in fluid communication with the proximal fluid reservoir.
31. A method for forming an open-irrigated catheter tip, comprising:
10 inserting a distal lip of a distal insert in a proximal end of the distal tip section;
seating mapping electrodes in mapping openings around a circumference of the distal insert; and
inserting a distal end of a proximal tip section over a proximal lip of the
15 distal insert.
32. The method of claim 31, further comprising inserting a thermocouple through an opening in the distal insert.
- 20 33. A catheter system for performing mapping and ablation functions, comprising:
a conductive exterior wall with mapping electrode openings, wherein the conductive exterior wall is configured for use in delivering RF energy for ablation functions;
25 mapping electrodes positioned in the mapping electrode openings; and
noise artifact isolators positioned in the mapping electrode openings, wherein the mapping electrodes are electrically insulated from the exterior wall by the noise artifact isolators.
- 30 34. The system of claim 33, wherein the mapping electrodes have an outside surface facing out from the exterior wall, and the noise artifact isolators have a lip extending outward from the exterior wall past the outside surface of the mapping electrodes.

35. An electrode assembly, comprising:
an electrode having a circumference defining sides of the electrode, a first surface, and a second surface opposite the first surface;
an electrode shaft extending from the second surface of the electrode,
5 wherein the electrode shaft is in electrical conduction with the electrode; and
a noise artifact isolator in contact with the sides of the electrode and surrounding the circumference of the electrode.
36. The electrode assembly of claim 35, wherein the noise artifact isolator
10 extends past the first surface of the electrode.
37. The electrode assembly of claim 35, wherein the noise artifact isolator is a polymer-based material.
- 15 38. A method of forming an open-irrigated catheter tip, comprising:
inserting a distal insert into a distal tip section, wherein the distal insert includes a distal extension and the distal tip section includes a distal end and irrigation ports separated from the distal end by a predetermined distance,
wherein inserting the distal insert includes moving the distal insert into the distal
20 tip section until the distal extension contacts the distal end of the distal tip section to self-position the distal insert proximate to the irrigation ports; and
connecting the distal tip section to a proximally adjacent structure,
wherein the distal insert partitions the distal tip section into a distal fluid reservoir between the distal insert and the distal end, and a proximal fluid
25 reservoir between the distal insert and the proximally adjacent structure, and
wherein the distal insert provide fluid communication between the distal and proximal fluid reservoirs.
39. The method of claim 38, wherein the distal insert includes a channel
30 isolated from fluid in the proximal fluid reservoir, and wherein inserting the distal insert into the distal tip section includes aligning mapping electrode apertures in the distal insert with mapping electrode apertures in the distal tip section, the method further comprising seating mapping electrodes into the

mapping electrode apertures, wherein wires connected to the mapping electrodes run through the channel of the distal insert.

5

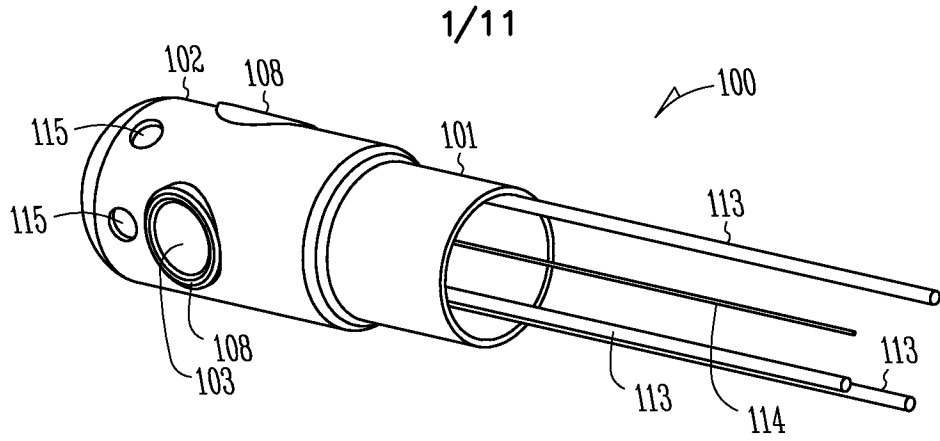

Fig. 1A

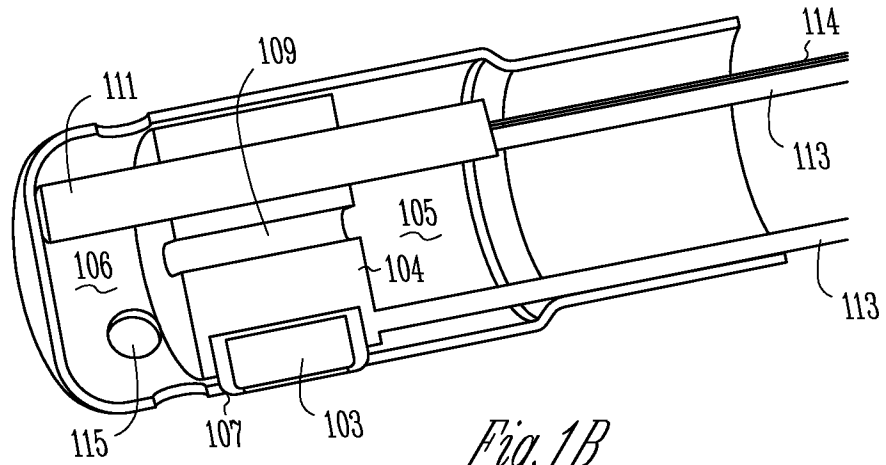

Fig. 1B

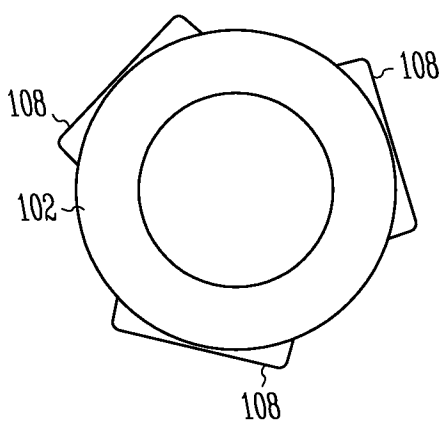

Fig. 1C

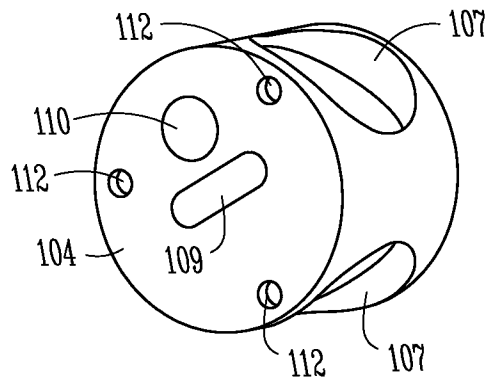

Fig. 1D

2/11

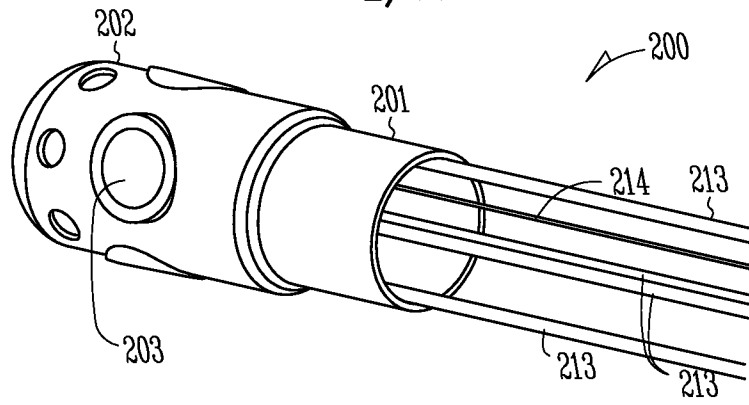

Fig. 2A

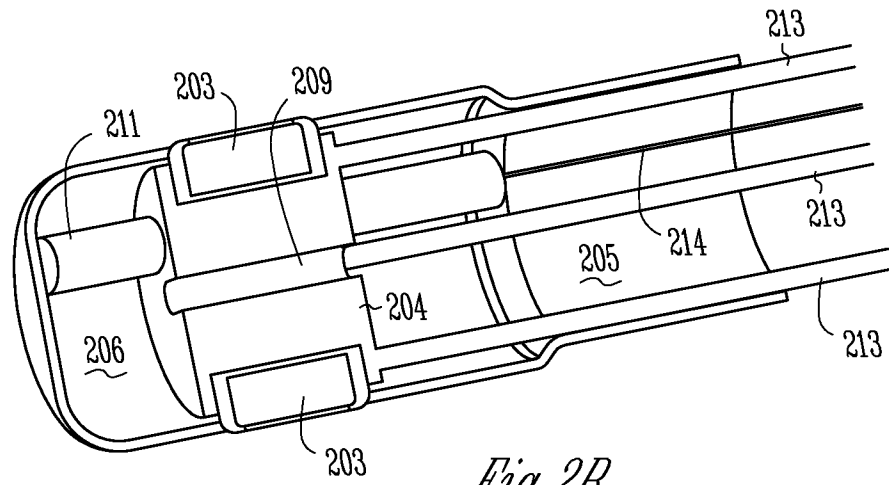

Fig. 2B

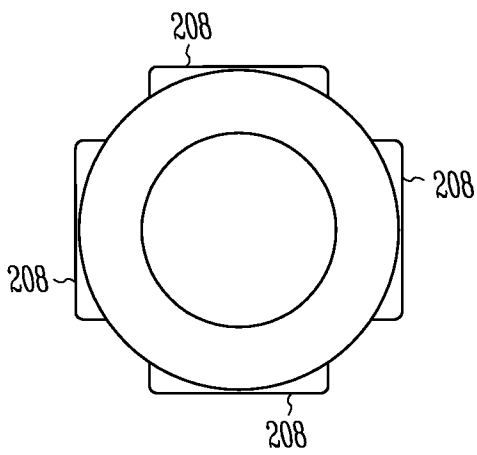

Fig. 2C

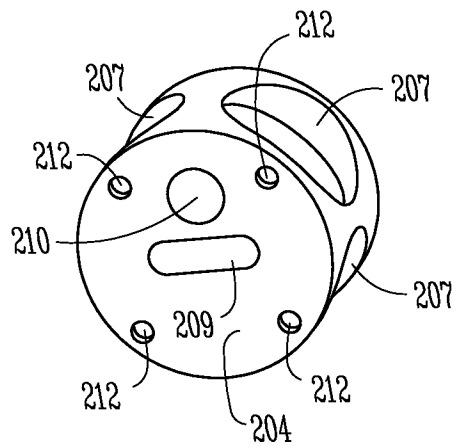

Fig. 2D

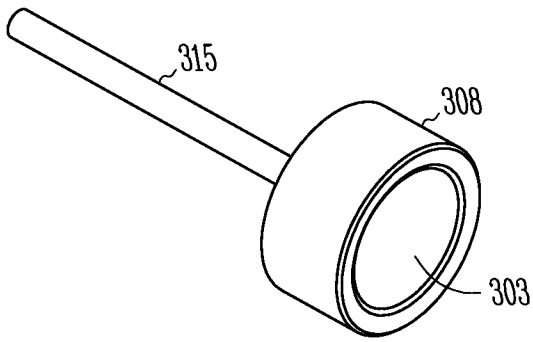

Fig. 3A

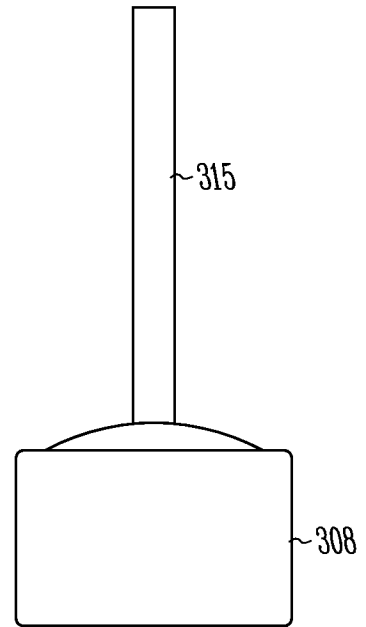

Fig. 3B

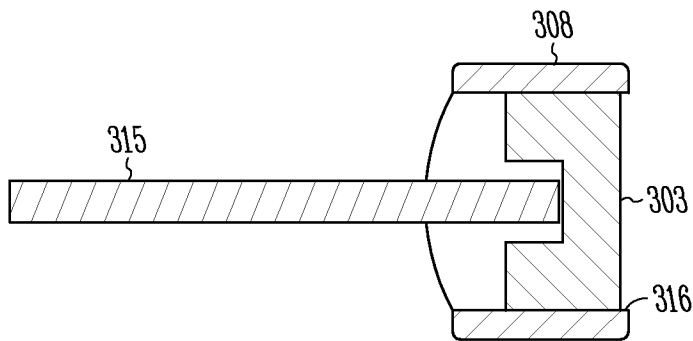

Fig. 3C

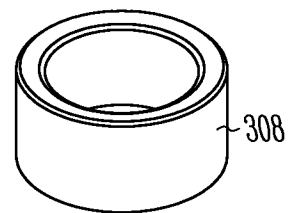

Fig. 3D

4/11

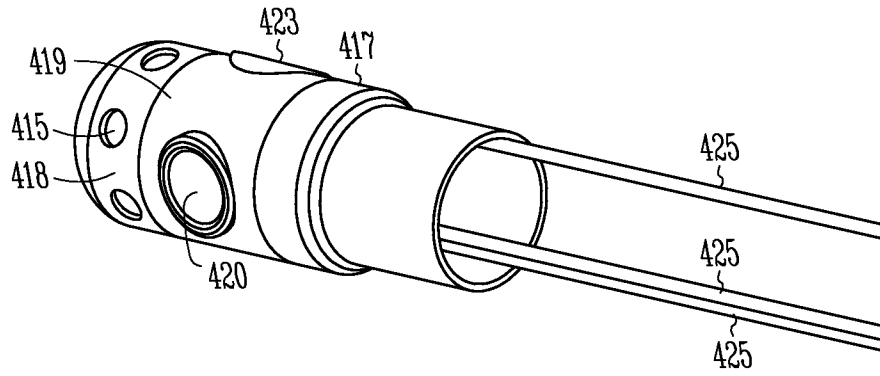

Fig. 4A

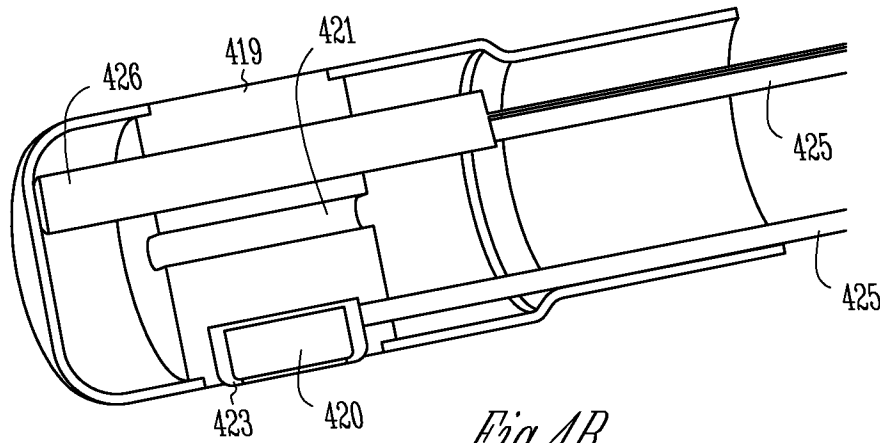

Fig. 4B

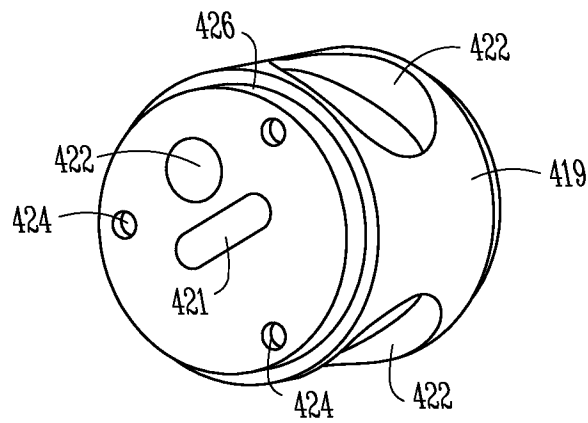

Fig. 4C

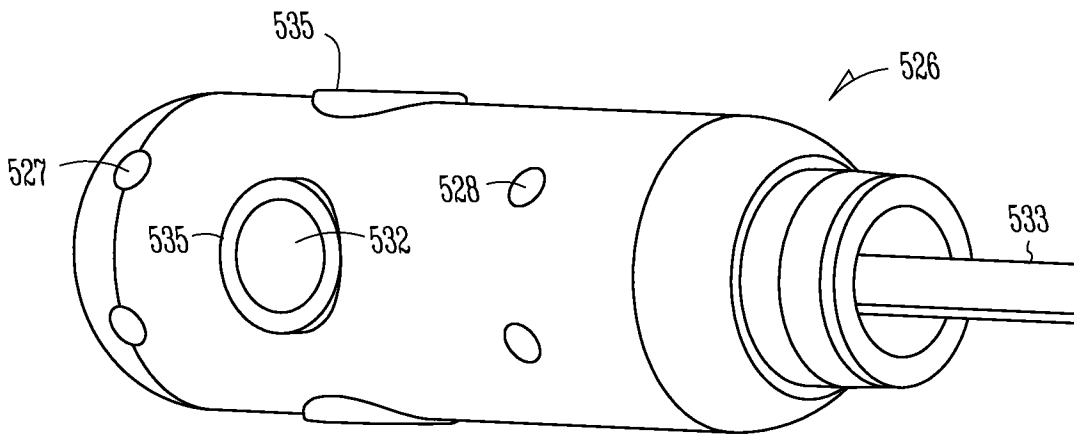

Fig. 5A

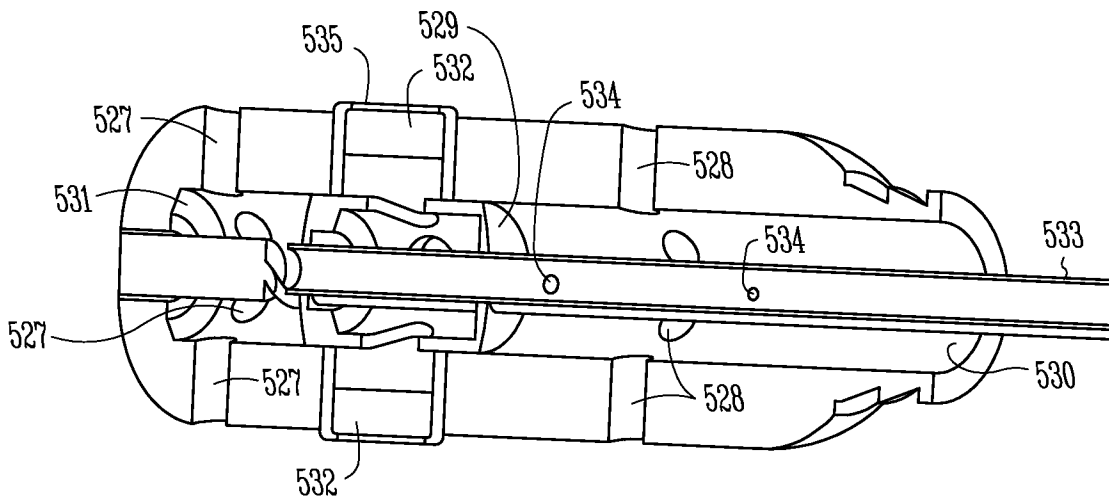

Fig. 5B

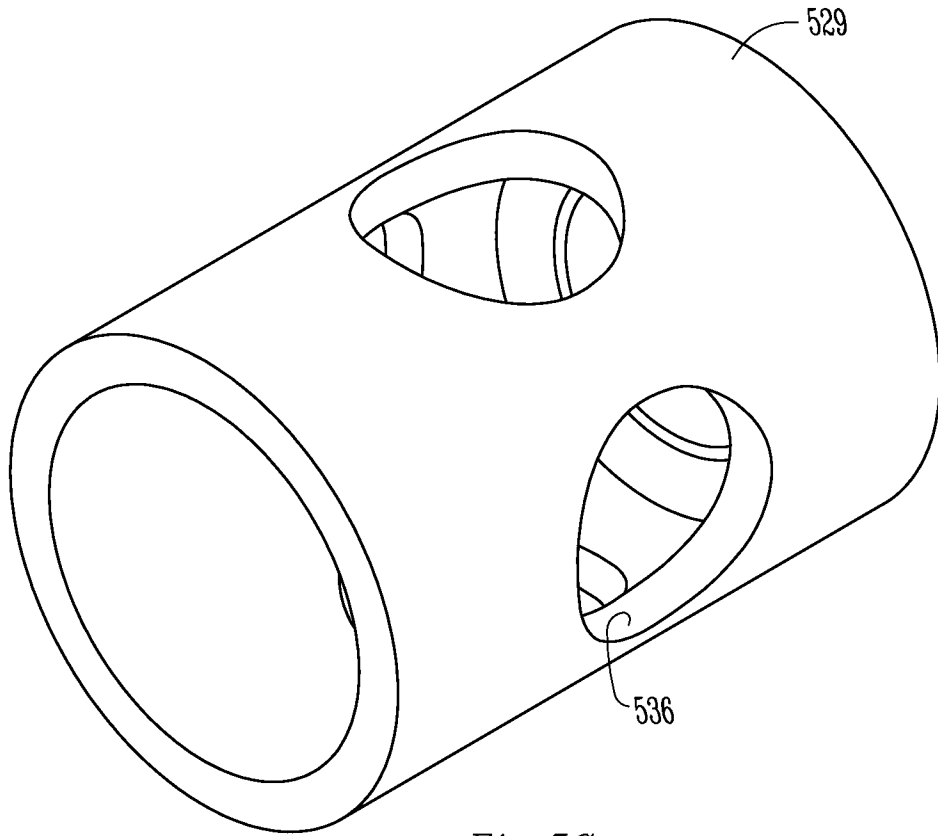

Fig. 5C

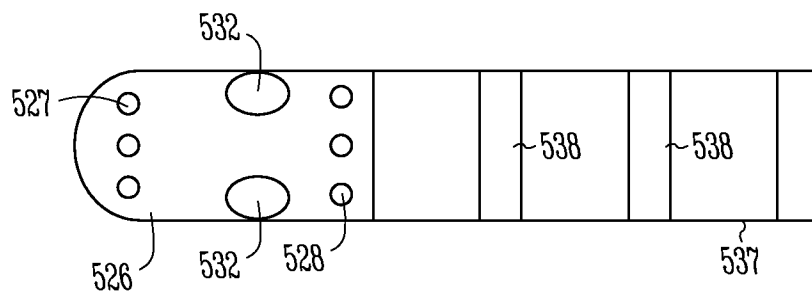

Fig. 5D

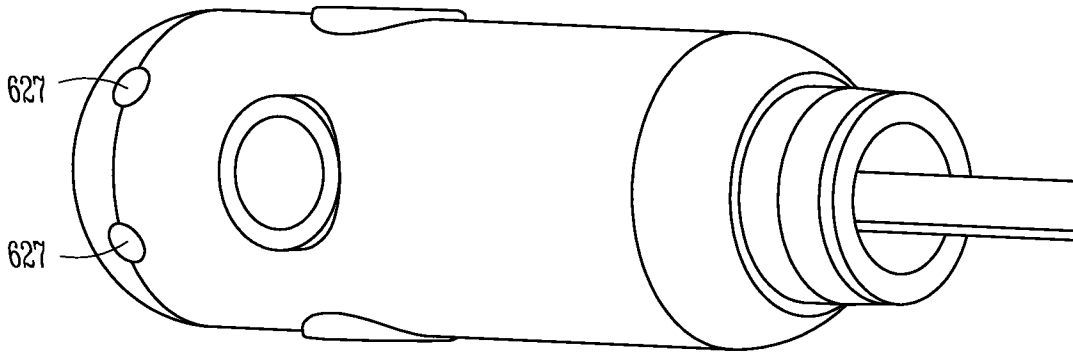

Fig. 6A

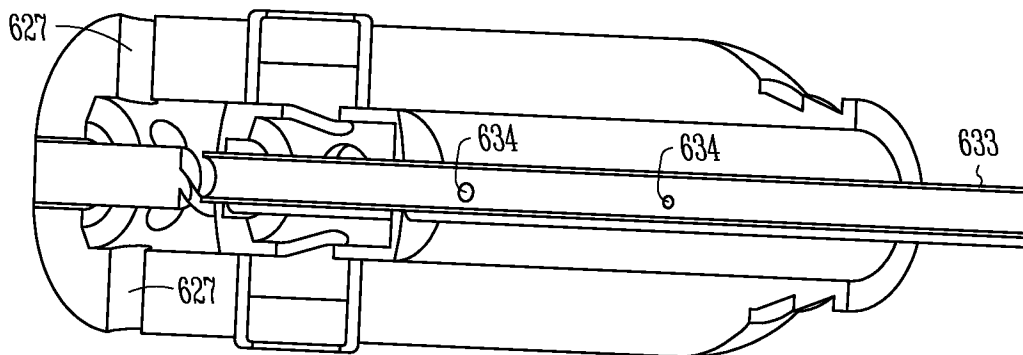

Fig. 6B

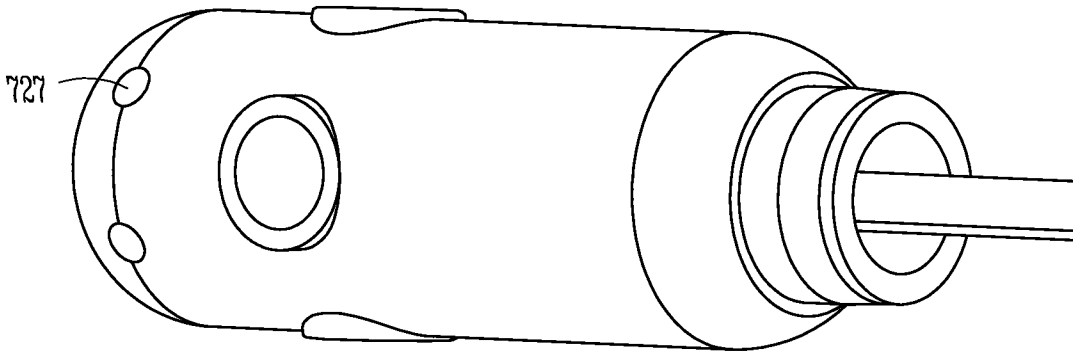

Fig. 7A

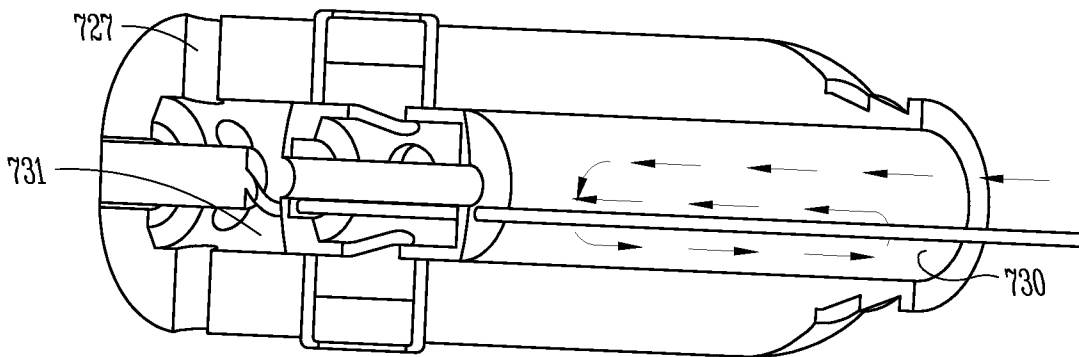
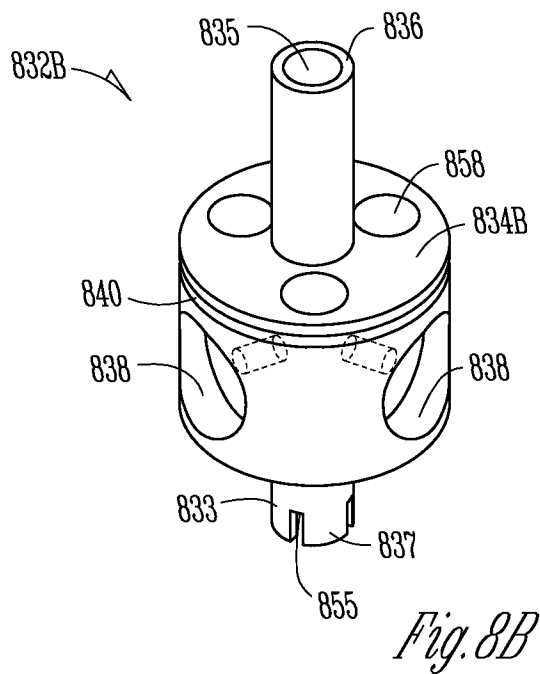
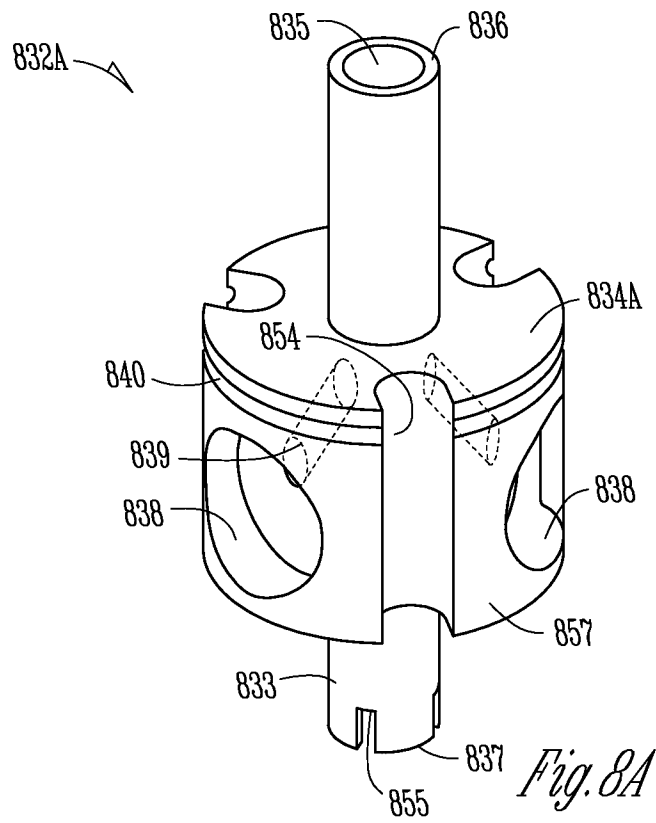

Fig. 7B

9/11



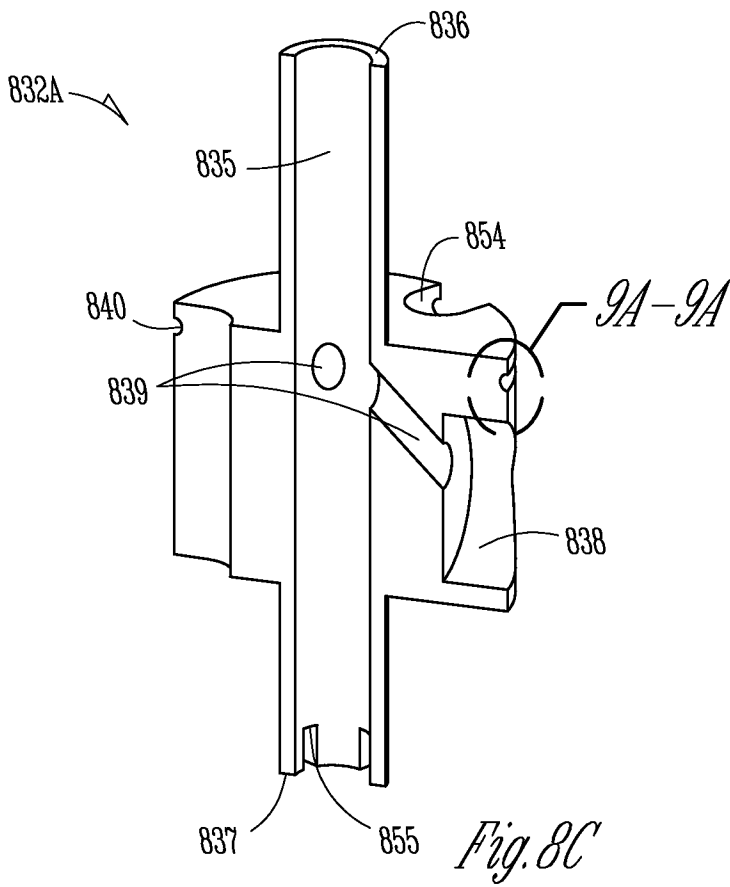

Fig. 8C

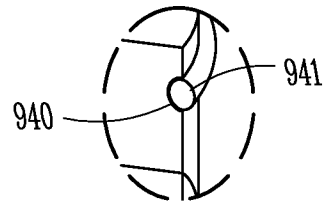

Fig. 9A

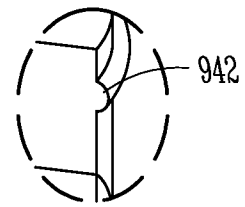

Fig. 9B

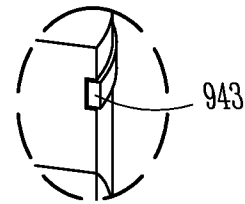

Fig. 9C

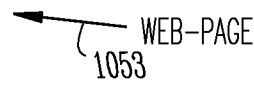
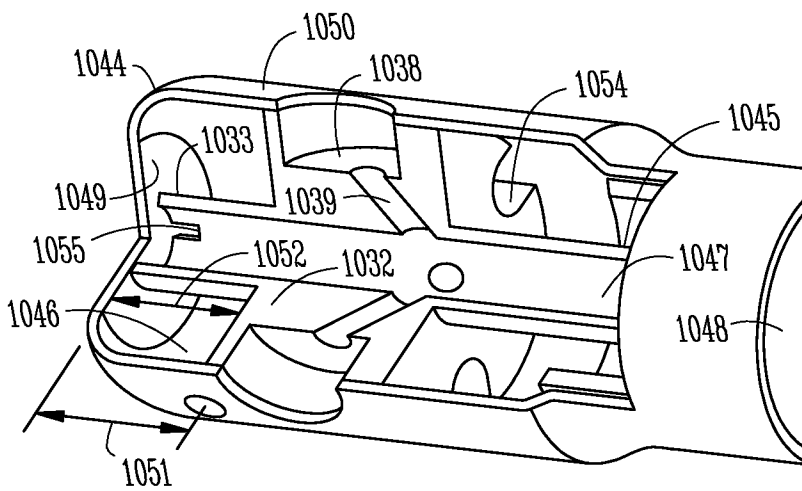

Fig. 10

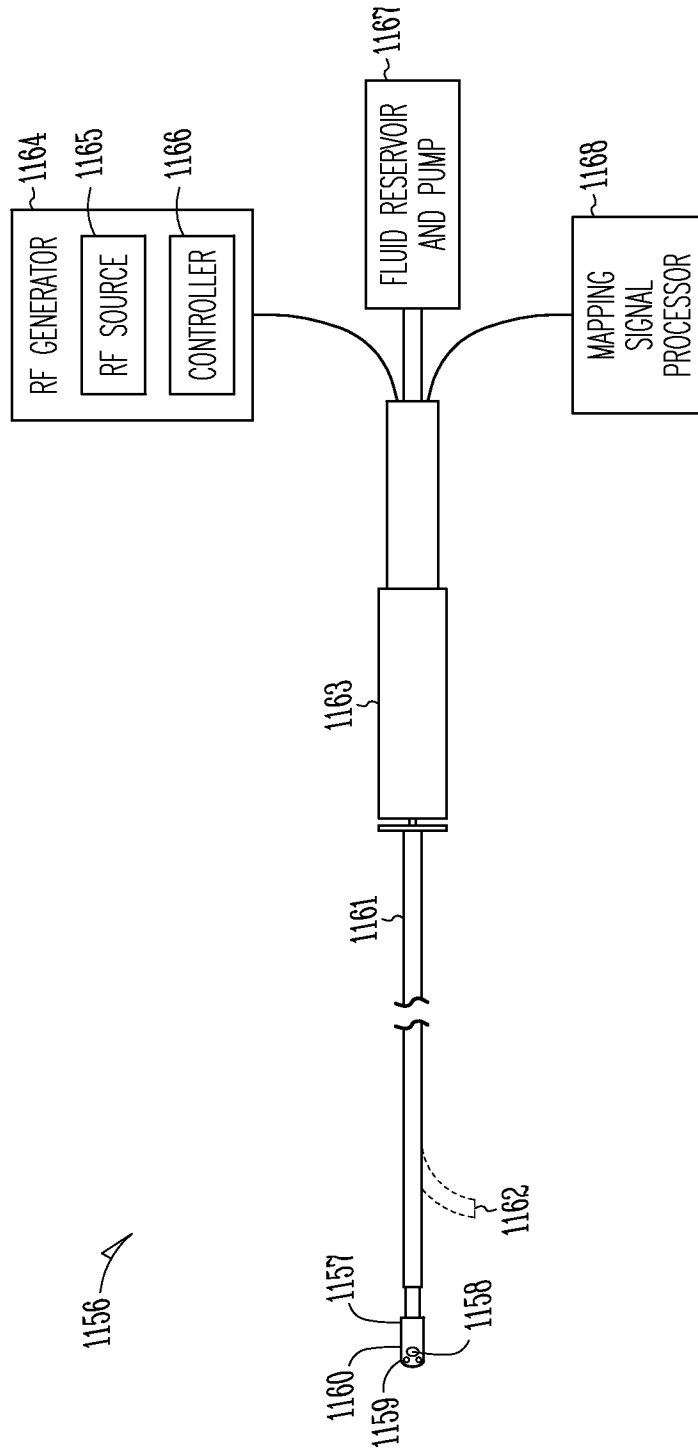

Fig. 11

INTERNATIONAL SEARCH REPORT

International application No
PCT/US2010/039600

A. CLASSIFICATION OF SUBJECT MATTER
 INV. A61B18/14 A61B5/042

According to International Patent Classification (IPC) or to both national classification and IPC

B. FIELDS SEARCHED

Minimum documentation searched (classification system followed by classification symbols)
 A61B

Documentation searched other than minimum documentation to the extent that such documents are included in the fields searched

Electronic data base consulted during the international search (name of data base and, where practical, search terms used)
 EPO-Internal

C. DOCUMENTS CONSIDERED TO BE RELEVANT

Category*	Citation of document, with indication, where appropriate, of the relevant passages	Relevant to claim No.
X	WO 2008/118992 A1 (BOSTON SCIENT SCIMED INC [US]; KOBLISH JOSEF V [US]) 2 October 2008 (2008-10-02)	33, 34
A	figures 2-9	1-30
X	US 2004/092806 A1 (SAGON STEPHEN W [US] ET AL) 13 May 2004 (2004-05-13)	33, 34
Y	figure 12 paragraph [0069] - paragraph [0072] paragraph [0085]	1-30
Y	US 2009/093810 A1 (SUBRAMANIAM RAJ [US] ET AL) 9 April 2009 (2009-04-09)	1-30
A	figures 1-7	
A	WO 2009/048943 A1 (BOSTON SCIENT SCIMED INC [US]) 16 April 2009 (2009-04-16)	1-30
	figure 3	

Further documents are listed in the continuation of Box C. See patent family annex.

* Special categories of cited documents :

<p>"A" document defining the general state of the art which is not considered to be of particular relevance</p> <p>"E" earlier document but published on or after the international filing date</p> <p>"L" document which may throw doubts on priority claim(s) or which is cited to establish the publication date of another citation or other special reason (as specified)</p> <p>"O" document referring to an oral disclosure, use, exhibition or other means</p> <p>"P" document published prior to the international filing date but later than the priority date claimed</p>	<p>"T" later document published after the international filing date or priority date and not in conflict with the application but cited to understand the principle or theory underlying the invention</p> <p>"X" document of particular relevance; the claimed invention cannot be considered novel or cannot be considered to involve an inventive step when the document is taken alone</p> <p>"Y" document of particular relevance; the claimed invention cannot be considered to involve an inventive step when the document is combined with one or more other such documents, such combination being obvious to a person skilled in the art.</p> <p>"&" document member of the same patent family</p>
--	--

Date of the actual completion of the international search	Date of mailing of the international search report
13 August 2010	10/11/2010

Name and mailing address of the ISA/ European Patent Office, P.B. 5818 Patentlaan 2 NL - 2280 HV Rijswijk Tel. (+31-70) 340-2040, Fax: (+31-70) 340-3016	Authorized officer Cornelissen, P
--	--

INTERNATIONAL SEARCH REPORT

International application No.
PCT/US2010/039600

Box No. II Observations where certain claims were found unsearchable (Continuation of item 2 of first sheet)

This international search report has not been established in respect of certain claims under Article 17(2)(a) for the following reasons:

1. Claims Nos.:
because they relate to subject matter not required to be searched by this Authority, namely:

2. Claims Nos.:
because they relate to parts of the international application that do not comply with the prescribed requirements to such an extent that no meaningful international search can be carried out, specifically:

3. Claims Nos.:
because they are dependent claims and are not drafted in accordance with the second and third sentences of Rule 6.4(a).

Box No. III Observations where unity of invention is lacking (Continuation of item 3 of first sheet)

This International Searching Authority found multiple inventions in this international application, as follows:

see additional sheet

1. As all required additional search fees were timely paid by the applicant, this international search report covers all searchable claims.

2. As all searchable claims could be searched without effort justifying an additional fees, this Authority did not invite payment of additional fees.

3. As only some of the required additional search fees were timely paid by the applicant, this international search report covers only those claims for which fees were paid, specifically claims Nos.:

4. No required additional search fees were timely paid by the applicant. Consequently, this international search report is restricted to the invention first mentioned in the claims; it is covered by claims Nos.:

1-30, 33, 34

Remark on Protest

- The additional search fees were accompanied by the applicant's protest and, where applicable, the payment of a protest fee.
- The additional search fees were accompanied by the applicant's protest but the applicable protest fee was not paid within the time limit specified in the invitation.
- No protest accompanied the payment of additional search fees.

INTERNATIONAL SEARCH REPORT

International Application No. PCT/US2010 /039600

FURTHER INFORMATION CONTINUED FROM PCT/ISA/ 210

This International Searching Authority found multiple (groups of) inventions in this international application, as follows:

1. claims: 1-30, 33, 34

A catheter system for performing mapping and ablation

2. claims: 31, 32

A method for forming a catheter tip

3. claims: 35-37

An electrode assembly

4. claims: 38, 39

A means for correct positioning a distal insert into a tip
section

INTERNATIONAL SEARCH REPORT

Information on patent family members

International application No

PCT/US2010/039600

Patent document cited in search report	Publication date	Patent family member(s)	Publication date
WO 2008118992	A1	02-10-2008	CA 2682055 A1 02-10-2008
			EP 2136702 A1 30-12-2009
			JP 2010522623 T 08-07-2010
			KR 20100021401 A 24-02-2010
			US 2008243214 A1 02-10-2008

US 2004092806	A1	13-05-2004	NONE

US 2009093810	A1	09-04-2009	CA 2699675 A1 16-04-2009
			EP 2217167 A1 18-08-2010
			EP 2211981 A1 04-08-2010
			KR 20100094449 A 26-08-2010
			WO 2009048824 A1 16-04-2009

WO 2009048943	A1	16-04-2009	US 2009093811 A1 09-04-2009
