

(19) World Intellectual Property Organization
International Bureau



(43) International Publication Date
10 May 2012 (10.05.2012)

PCT

(10) International Publication Number
WO 2012/061727 A2

(51) International Patent Classification:

A61B 18/14 (2006.01) A61B 19/00 (2006.01)
A61B 17/32 (2006.01) G02B 27/00 (2006.01)
G02B 27/01 (2006.01) A61B 17/00 (2006.01)

(21) International Application Number:

PCT/US2011/059365

(22) International Filing Date:

4 November 2011 (04.11.2011)

(25) Filing Language:

English

(26) Publication Language:

English

(30) Priority Data:

61/410,603 5 November 2010 (05.11.2010) US
61/487,846 19 May 2011 (19.05.2011) US
13/276,687 19 October 2011 (19.10.2011) US

(71) Applicant (for all designated States except US):

ETHICON ENCO-SURGERY, INC. [US/US]; 4545
Creek Road, Cincinnati, OH 45242 (US).

(72) Inventors; and

(75) Inventors/Applicants (for US only): PRICE, Daniel, W.
[US/US]; 185 Overlook Drive, Loveland, OH 45140
(US). KIMBALL, Cory, G. [US/US]; 6136 Lagrange
Lane, Cincinnati, OH 45239 (US).

(74) Agents: JOHNSON, Philip, S. et al.; Johnson & John-
son, One Johnson & Johnson Plaza, New Brunswick, NJ
08933 (US).

(81) Designated States (unless otherwise indicated, for every
kind of national protection available): AE, AG, AL, AM,

AO, AT, AU, AZ, BA, BB, BG, BH, BR, BW, BY, BZ,
CA, CH, CL, CN, CO, CR, CU, CZ, DE, DK, DM, DO,
DZ, EC, EE, EG, ES, FI, GB, GD, GE, GH, GM, GT,
HN, HR, HU, ID, IL, IN, IS, JP, KE, KG, KM, KN, KP,
KR, KZ, LA, LC, LK, LR, LS, LT, LU, LY, MA, MD,
ME, MG, MK, MN, MW, MX, MY, MZ, NA, NG, NI,
NO, NZ, OM, PE, PG, PH, PL, PT, QA, RO, RS, RU,
RW, SC, SD, SE, SG, SK, SL, SM, ST, SV, SY, TH, TJ,
TM, TN, TR, TT, TZ, UA, UG, US, UZ, VC, VN, ZA,
ZM, ZW.

(84) Designated States (unless otherwise indicated, for every
kind of regional protection available): ARIPO (BW, GH,
GM, KE, LR, LS, MW, MZ, NA, RW, SD, SL, SZ, TZ,
UG, ZM, ZW), Eurasian (AM, AZ, BY, KG, KZ, MD,
RU, TJ, TM), European (AL, AT, BE, BG, CH, CY, CZ,
DE, DK, EE, ES, FI, FR, GB, GR, HR, HU, IE, IS, IT,
LT, LU, LV, MC, MK, MT, NL, NO, PL, PT, RO, RS,
SE, SI, SK, SM, TR), OAPI (BF, BJ, CF, CG, CI, CM,
GA, GN, GQ, GW, ML, MR, NE, SN, TD, TG).

Declarations under Rule 4.17:

- as to the identity of the inventor (Rule 4.17(i))
- as to applicant's entitlement to apply for and be granted
a patent (Rule 4.17(ii))
- as to the applicant's entitlement to claim the priority of
the earlier application (Rule 4.17(iii))

Published:

- without international search report and to be republished
upon receipt of that report (Rule 48.2(g))

(54) Title: SURGICAL INSTRUMENT SAFETY GLASSES

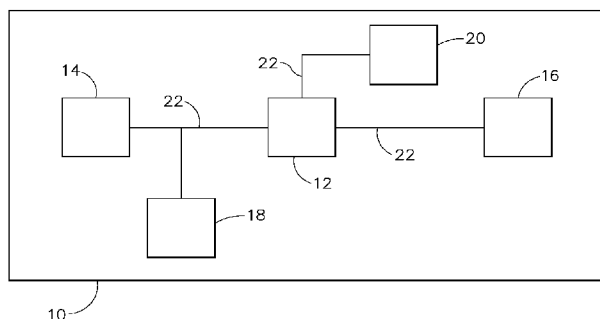

Fig. 1

(57) Abstract: A surgical instrument includes a handle assembly housing a wireless circuit board. The wireless circuit board transmits a signal to a set of safety glasses worn by a surgeon using the surgical instrument during a procedure. The signal is received by a wireless port on the safety glasses. One or more lighting devices on a front lens the safety glasses change color, fade, or glow in response to the received signal to indicate information to the surgeon about the status of the surgical instrument. The lighting devices are disposable on peripheral edges of the front lens to not distract the direct line of vision of the surgeon.

WO 2012/061727 A2

SURGICAL INSTRUMENT SAFETY GLASSES

Daniel W. Price

Cory G. Kimball

PRIORITY

[0001] This application claims priority to U.S. Provisional Application Serial No. 61/410,603, filed November 5, 2010, entitled "Energy-Based Surgical Instruments," the disclosure of which is incorporated by reference herein.

[0002] This application also claims priority to U.S. Provisional Application Serial No. 61/487,846, filed May 19, 2011, entitled "Energy-Based Surgical Instruments," the disclosure of which is incorporated by reference herein.

[0003] This application also claims priority to U.S. Nonprovisional Application Serial No.13/276,687 filed October 19, 2011, entitled "Surgical Instrument Safety Glasses," the disclosure of which is incorporated by reference herein.

BACKGROUND

[0004] In some settings, endoscopic surgical instruments may be preferred over traditional open surgical devices since a smaller incision may reduce the post-operative recovery time and complications. Consequently, some endoscopic surgical instruments may be suitable for placement of a distal end effector at a desired surgical site through a cannula of a trocar. These distal end effectors may engage tissue in a number of ways to achieve a diagnostic or therapeutic effect (e.g., endocutter, grasper, cutter, stapler, clip applier, access device, drug/gene therapy delivery device, and energy delivery device using ultrasound, RF, laser, etc.). Endoscopic surgical instruments may include a shaft between the end effector and a handle portion, which is manipulated by the clinician. Such a shaft may enable insertion to a desired depth and rotation about the longitudinal axis of the shaft, thereby facilitating positioning of the end effector within the patient.

[0005] Examples of endoscopic surgical instruments include those disclosed in U.S. Pat. Pub. No. 2006/0079874, entitled "Tissue Pad Use with an Ultrasonic Surgical

Instrument,” published April 13, 2006, the disclosure of which is incorporated by reference herein; U.S. Pat. Pub. No. 2007/0191713, entitled “Ultrasonic Device for Cutting and Coagulating,” published August 16, 2007, the disclosure of which is incorporated by reference herein; U.S. Pat. Pub. No. 2007/0282333, entitled “Ultrasonic Waveguide and Blade,” published December 6, 2007, the disclosure of which is incorporated by reference herein; U.S. Pat. Pub. No. 2008/0200940, entitled “Ultrasonic Device for Cutting and Coagulating,” published August 21, 2008, the disclosure of which is incorporated by reference herein; U.S. Pat. Pub. No. 2009/0209990 entitled “Motorized Surgical Cutting and Fastening Instrument Having Handle Based Power Source,” published August 20, 2009, the disclosure of which is incorporated by reference herein; and U.S. Pat. Pub. No. 2010/0069940 entitled “Ultrasonic Device for Fingertip Control,” published March 18, 2010, the disclosure of which is incorporated by reference herein; U.S. Pat. Pub. No. 2011/0015660, entitled “Rotating Transducer Mount for Ultrasonic Surgical Instruments,” published January 20, 2011, the disclosure of which is incorporated by reference herein; U.S. Pat. No. 6,500,176, entitled “Electrosurgical Systems and Techniques for Sealing Tissue,” issued December 31, 2002, the disclosure of which is incorporated by reference herein; U.S. Pat. No. 7,416,101 entitled “Motor-Driven Surgical Cutting and Fastening Instrument with Loading Force Feedback,” issued August 26, 2008, the disclosure of which is incorporated by reference herein; U.S. Pat. No. 7,738,971 entitled “Post-Sterilization Programming of Surgical Instruments,” issued June 15, 2010, the disclosure of which is incorporated by reference herein; and U.S. Pat. Pub. No. 2011/0087218, entitled “Surgical Instrument Comprising First and Second Drive Systems Actuable by a Common Trigger Mechanism,” published April 14, 2011, the disclosure of which is incorporated by reference herein. Additionally, such surgical tools may include a cordless transducer such as that disclosed in U.S. Pat. Pub. No. 2009/0143797, entitled “Cordless Hand-held Ultrasonic Cautery Cutting Device,” published June 4, 2009, the disclosure of which is incorporated by reference herein. In addition, the surgical instruments may be used, or adapted for use, in robotic-assisted surgery settings such as that disclosed in U.S. Pat. No. 6,783,524, entitled “Robotic Surgical Tool with Ultrasound Cauterizing and Cutting Instrument,” issued August 31, 2004.

[0006] While several systems and methods have been made and used for surgical instruments, it is believed that no one prior to the inventors has made or used the invention described in the appended claims.

BRIEF DESCRIPTION OF THE DRAWINGS

[0007] While the specification concludes with claims which particularly point out and distinctly claim this technology, it is believed this technology will be better understood from the following description of certain examples taken in conjunction with the accompanying drawings, in which like reference numerals identify the same elements and in which:

[0008] FIG. 1 depicts a schematic view of an exemplary medical device having an internal power source;

[0009] FIG. 2 depicts a perspective view of an exemplary medical device having an internal power source;

[0010] FIG. 3 depicts a elevation view of an exemplary surgical monitor displaying an end effector of the surgical instrument of FIG. 1 in use;

[0011] FIG. 4 depicts a perspective view of an exemplary generator and first wireless transmitter submitting a signal to a second wireless transmitter of a second procedure monitoring system;

[0012] FIG. 5 depicts a perspective view of a surgeon using the exemplary surgical instrument of FIG. 1 during a surgical procedure, with the surgeon wearing a set of exemplary safety glasses;

[0013] FIG. 6 depicts a perspective view of a version of the safety glasses of FIG. 5;

[0014] FIG. 7 depicts an elevation view of an alternative version of the safety glasses of FIG. 5; and

[0015] FIG. 8 depicts an elevation view of another alternative version of the safety glasses of FIG. 5.

[0016] The drawings are not intended to be limiting in any way, and it is contemplated that various embodiments of the technology may be carried out in a variety of other ways, including those not necessarily depicted in the drawings. The accompanying drawings incorporated in and forming a part of the specification illustrate several aspects of the present technology, and together with the description serve to explain the principles of the technology; it being understood, however, that this technology is not limited to the precise arrangements shown.

DETAILED DESCRIPTION

[0017] The following description of certain examples of the technology should not be used to limit its scope. Other examples, features, aspects, embodiments, and advantages of the technology will become apparent to those skilled in the art from the following description, which is by way of illustration, one of the best modes contemplated for carrying out the technology. As will be realized, the technology described herein is capable of other different and obvious aspects, all without departing from the technology. Accordingly, the drawings and descriptions should be regarded as illustrative in nature and not restrictive.

[0018] I. Medical Devices for Use With Insertable or Reclaimable Components

[0019] FIG. 1 shows components of an exemplary medical device (10) in diagrammatic block form. As shown, medical device (10) comprises a control module (12), a power source (14), and an end effector (16). Merely exemplary power sources (14) may include NiMH batteries, Li-ion batteries (e.g., prismatic cell type lithium ion batteries, etc.), Ni-Cad batteries, or any other type of power source as may be apparent to one of ordinary skill in the art in light of the teachings herein. Control module (12) may comprise a microprocessor, an application specific integrated circuit (ASIC), memory, a printed circuit board (PCB), a storage device (such as a solid state drive or hard disk), firmware, software, or any other suitable control module components as will be apparent to one of

ordinary skill in the art in light of the teachings herein. Control module (12) and power source (14) are coupled by an electrical connection (22), such as a cable and/or traces in a circuit board, etc., to transfer power from power source (14) to control module (12). Alternatively, power source (14) may be selectively coupled to control module (12). This allows power source (14) to be detached and removed from medical device (10), which may further allow power source (14) to be readily recharged or reclaimed for resterilization and reuse, such as in accordance with the various teachings herein. In addition or in the alternative, control module (12) may be removed for servicing, testing, replacement, or any other purpose as will be apparent to one of ordinary skill in the art in view of the teachings herein.

[0020] End effector (16) is coupled to control module (12) by another electrical connection (22). End effector (16) is configured to perform a desired function of medical device (10). By way of example only, such function may include cauterizing tissue, ablating tissue, severing tissue, ultrasonically vibrating, stapling tissue, or any other desired task for medical device (10). End effector (16) may thus include an active feature such as an ultrasonic blade, a pair of clamping jaws, a sharp knife, a staple driving assembly, a monopolar RF electrode, a pair of bipolar RF electrodes, a thermal heating element, and/or various other components. End effector (16) may also be removable from medical device (10) for servicing, testing, replacement, or any other purpose as will be apparent to one of ordinary skill in the art in view of the teachings herein. In some versions, end effector (16) is modular such that medical device (10) may be used with different kinds of end effectors (e.g., as taught in U.S. Provisional Application Serial No. 61/410,603, etc.). Various other configurations of end effector (16) may be provided for a variety of different functions depending upon the purpose of medical device (10) as will be apparent to those of ordinary skill in the art in view of the teachings herein. Similarly, other types of components of a medical device (10) that may receive power from power source (14) will be apparent to those of ordinary skill in the art in view of the teachings herein.

[0021] Medical device (10) of the present example includes a trigger (18) and a sensor (20), though it should be understood that such components are merely optional. Trigger

(18) is coupled to control module (12) and power source (14) by electrical connection (22). Trigger (18) may be configured to selectively provide power from power source (14) to end effector (16) (and/or to some other component of medical device (10)) to activate medical device (10) when performing a procedure. Sensor (20) is also coupled to control module (12) by an electrical connection (22) and may be configured to provide a variety of information to control module (12) during a procedure. By way of example only, such configurations may include sensing a temperature at end effector (16) or determining the oscillation rate of end effector (16). Data from sensor (20) may be processed by control module (12) to effect the delivery of power to end effector (16) (e.g., in a feedback loop, etc.). Various other configurations of sensor (20) may be provided depending upon the purpose of medical device (10) as will be apparent to those of ordinary skill in the art in view of the teachings herein. Of course, as with other components described herein, medical device (10) may have more than one sensor (20), or sensor (20) may simply be omitted if desired.

[0022] FIG. 2 depicts a merely exemplary form that medical device (10) may take. In particular, FIG. 2 shows a medical device (100) comprising a power source (110), a control module (120), a housing (130), end effector (140), and an electrical connection (150). In the present example, power source (110) is located internally within housing (130) of medical device (100). Alternatively, power source (110) may only partially extend into housing (130) and may be selectively attachable to a portion of housing (130). In yet a further exemplary configuration, a portion of housing (130) may extend into power source (110) and power source (110) may be selectively attachable to the portion of housing (130). Power source (110) may also be configured to detach from medical device (100) and decouple from control module (120) or electrical connection (150). As a result, power source (110) may be completely separated from medical device (100) in some versions. By way of example only, power source (110) may be constructed in accordance with the teachings of U.S. Pub. No. 2011/0087212, entitled "Surgical Generator for Ultrasonic and Electrosurgical Devices," published April 14, 2011, the disclosure of which is incorporated by reference herein. In some versions, power source (110) may be removed to be recharged or reclaimed for resterilization and reuse, such as in accordance with various teachings herein. After recharging, or after an

initial charge, power source (110) may be inserted or reinserted into medical device (100) and secured to housing (130) or internally within housing (130). Of course, medical device (100) may also allow power source (110) to be charged and/or recharged while power source (110) is still in or otherwise coupled relative to housing (130).

[0023] It should also be understood that control module (120) may be removed for servicing, testing, replacement, or any other purpose as will be apparent to one of ordinary skill in the art in view of the teachings herein. Further, end effector (140) may also be removable from medical device (100) for servicing, testing, replacement, or any other purpose as will be apparent to one of ordinary skill in the art in view of the teachings herein.

[0024] While certain configurations of an exemplary medical device (100) have been described, various other ways in which medical device (100) may be configured will be apparent to those of ordinary skill in the art in view of the teachings herein. By way of example only, medical devices (10, 100) and/or any other medical device referred to herein may be constructed in accordance with at least some of the teachings of U.S. Pat. No. 5,322,055 entitled "Clamp Coagulator/Cutting System for Ultrasonic Surgical Instruments," issued June 21, 1994, the disclosure of which is incorporated by reference herein; U.S. Pat. No. 5,873,873 entitled "Ultrasonic Clamp Coagulator Apparatus Having Improved Clamp Mechanism," issued February 23, 1999, the disclosure of which is incorporated by reference herein; U.S. Pat. No. 5,980,510, entitled "Ultrasonic Clamp Coagulator Apparatus Having Improved Clamp Arm Pivot Mount," filed October 10, 1997, the disclosure of which is incorporated by reference herein; U.S. Pat. No. 6,325,811 entitled "Blades with Functional Balance Asymmetries for use with Ultrasonic Surgical Instruments," issued December 4, 2001, the disclosure of which is incorporated by reference herein; U.S. Pub. No. 2006/0079874 entitled "Tissue Pad for Use with an Ultrasonic Surgical Instrument," published April 13, 2006, the disclosure of which is incorporated by reference herein; U.S. Pub. No. 2007/0191713 entitled "Ultrasonic Device for Cutting and Coagulating," published August 16, 2007, the disclosure of which is incorporated by reference herein; U.S. Pub. No. 2007/0282333 entitled "Ultrasonic Waveguide and Blade," published December 6, 2007, the disclosure of which is

incorporated by reference herein; U.S. Pub. No. 2008/0200940 entitled “Ultrasonic Device for Cutting and Coagulating,” published August 21, 2008, the disclosure of which is incorporated by reference herein; U.S. Pub. No. 2009/0143797, entitled “Cordless Hand-held Ultrasonic Cautery Cutting Device,” published June 4, 2009, the disclosure of which is incorporated by reference herein; U.S. Pub. No. 2010/0069940 entitled “Ultrasonic Device for Fingertip Control,” published March 18, 2010, the disclosure of which is incorporated by reference herein; U.S. Pub. No. 2011/0015660, entitled “Rotating Transducer Mount for Ultrasonic Surgical Instruments,” published January 20, 2011, the disclosure of which is incorporated by reference herein; and/or U.S. Provisional Application Serial No. 61/410,603, filed November 5, 2010, entitled “Energy-Based Surgical Instruments,” the disclosure of which is incorporated by reference herein.

[0025] Of course, housing (130) and medical device (100) may include other configurations. For instance, housing (130) and/or medical device (100) may include a tissue cutting element and one or more elements that transmit bipolar RF energy to tissue (e.g., to coagulate or seal the tissue). An example of such a device is the ENSEAL® Tissue Sealing Device by Ethicon Endo-Surgery, Inc., of Cincinnati, Ohio. Further examples of such devices and related concepts are disclosed in U.S. Pat. No. 6,500,176 entitled “Electrosurgical Systems and Techniques for Sealing Tissue,” issued December 31, 2002, the disclosure of which is incorporated by reference herein; U.S. Pat. No. 7,112,201, entitled “Electrosurgical Instrument and Method of Use,” issued September 26, 2006, the disclosure of which is incorporated by reference herein; U.S. Pat. No. 7,125,409, entitled “Electrosurgical Working End for Controlled Energy Delivery,” issued October 24, 2006, the disclosure of which is incorporated by reference herein; U.S. Pat. No. 7,169,146 entitled “Electrosurgical Probe and Method of Use,” issued January 30, 2007, the disclosure of which is incorporated by reference herein; U.S. Pat. No. 7,186,253, entitled “Electrosurgical Jaw Structure for Controlled Energy Delivery,” issued March 6, 2007, the disclosure of which is incorporated by reference herein; U.S. Pat. No. 7,189,233, entitled “Electrosurgical Instrument,” issued March 13, 2007, the disclosure of which is incorporated by reference herein; U.S. Pat. No. 7,220,951, entitled “Surgical Sealing Surfaces and Methods of Use,” issued May 22, 2007, the disclosure of which is incorporated by reference herein; U.S. Pat. No. 7,309,849, entitled “Polymer

Compositions Exhibiting a PTC Property and Methods of Fabrication,” issued December 18, 2007, the disclosure of which is incorporated by reference herein; U.S. Pat. No. 7,311,709, entitled “Electrosurgical Instrument and Method of Use,” issued December 25, 2007, the disclosure of which is incorporated by reference herein; U.S. Pat. No. 7,354,440, entitled “Electrosurgical Instrument and Method of Use,” issued April 8, 2008, the disclosure of which is incorporated by reference herein; U.S. Pat. No. 7,381,209, entitled “Electrosurgical Instrument,” issued June 3, 2008, the disclosure of which is incorporated by reference herein; U.S. Pub. No. 2011/0087218, entitled “Surgical Instrument Comprising First and Second Drive Systems Actuable by a Common Trigger Mechanism,” published April 14, 2011, the disclosure of which is incorporated by reference herein; and U.S. Pat. App. No. 13/151,181, entitled “Motor Driven Electrosurgical Device with Mechanical and Electrical Feedback,” filed June 2, 2011, the disclosure of which is incorporated by reference herein.

[0026] It is further understood that any one or more of the teachings, expressions, embodiments, examples, etc. described herein may be combined with any one or more of the other teachings, expressions, embodiments, examples, etc. that are described herein. The following-described teachings, expressions, embodiments, examples, etc. should therefore not be viewed in isolation relative to each other. Various suitable ways in which the teachings herein may be combined will be readily apparent to those of ordinary skill in the art in view of the teachings herein. Such modifications and variations are intended to be included within the scope of the claims.

[0027] II. Exemplary Safety Glasses and Monitoring Systems

[0028] Examples described below relate to uses of exemplary safety glasses and monitoring systems with ultrasonic surgical instruments, though such use is possible with other instruments, such as electrosurgical devices energized with RF energy and/or any other type of instrument such as medical devices (10, 100) described above and described in the various references cited herein. Throughout this disclosure, reference numbers utilized with different alphanumeric extensions indicate similar components in different versions of a described reference (i.e., lenses (422, 422A, 422B)). Additional exemplary

modifications that may be provided for medical device (10, 100) will be described in greater detail below. Various suitable ways in which the below teachings may be incorporated with medical device (10, 100) will be apparent to those of ordinary skill in the art. Similarly, various suitable ways in which the below teachings may be combined with various teachings of the references cited herein will be apparent to those of ordinary skill in the art. It should also be understood that the below teachings are not limited to medical device (10, 100) or devices taught in the references cited herein. Various other suitable devices and settings in which the below teachings may be applied will be apparent to those of ordinary skill in the art in view of the teachings herein.

[0029] A. Exemplary Monitoring Systems

[0030] FIG. 3 shows exemplary procedure or surgical monitor (400). Surgical monitor (400) may be used to broadcast video from a device such as a laparoscope, for example, during a surgical procedure. FIG. 3 shows surgical monitor (400) broadcasting video of exemplary end effector (80) of exemplary surgical instrument (50) severing tissue (90) of a patient. Surgical instrument (50) is similar in operation and construction to exemplary medical device (10, 100) described above. Surgical instrument (50) may be an ultrasonic surgical instrument or a radio frequency based surgical instrument as described above and/or in accordance with any of the references cited herein. By way of example only, an associated base station may be constructed and operable in accordance with U.S. Provisional Application Serial No. 61/410,603, filed November 5, 2010, entitled "Energy-Based Surgical Instruments," the disclosure of which is incorporated by reference herein. The base station may be, for example, procedure monitoring system (402) shown in FIG. 4, and described below. Procedure monitoring system (402) could superimpose directions or instructions (404) on surgical monitor (400) to aid a surgeon during the procedure. For example, screen (406) of surgical monitor (400) may display instructions (404) in instruction display box (408). For example, a display in box (408) may indicate that a desired seal by end effector (80) has been completed by a visual signal such as a symbol or a written message. Procedure monitoring system (402) may also be used to aid in troubleshooting issues within exemplary instrument (50) or an

associated electronics module within instrument (50) before, during, or after the procedure.

[0031] As shown in FIG. 4, generator (410) provides power or other signal to instrument (50). Generator (410) includes transmitter (412) which may be connected to an external USB port of generator (410). Transmitter (412) may be, for example, a Bluetooth® wireless transmitter or fob to submit a wireless signal, depicted by arrow (A), to surgery or procedure monitoring system (402). Procedure monitoring system (402) includes receiver (414), which may be a Bluetooth® transmitter or fob that receives the signal from generator (410). Bluetooth® is a registered trademark of Bluetooth SIG, Inc. of Kirkland, Washington. Other wireless devices to transmit and receive wireless signals apparent to those of ordinary skill in the art in view of the teachings herein are within the scope of this disclosure. Procedure monitoring system (402) would not only receive a signal from generator (410), but may also include the programming and drivers needed to display information on a procedure screen such as surgical monitor (400). Procedure monitoring system (402) may be directly connected to surgical monitor (400) via a wireless or a wired connection to submit the received signal to surgical monitor (400). Additionally or alternatively, a wireless communications board or circuit board may be housed in a multi-piece handle assembly of instrument (50) to communicate information via a two-way link with a base station such as procedure monitoring system (402) of FIG. 4. In some versions, instrument (50) is battery operated and includes a transmitter. A base station communicating with instrument (50) may receive the transmitted data from instrument (50) and display the information, as described above, onto surgical monitor (400) or another troubleshooting device as will be apparent to those of ordinary skill in the art in view of the teachings herein.

[0032] Information displayable on surgical monitor (400) and received by monitor (400) as described above may include, but is not limited to including, a seal completion indicator, a generator power setting showing a minimum or a maximum power setting, for example, and/or a correct technique indicator (indicating when a technique is being improperly performed). Regarding the seal completion indicator, a generator algorithm may indicate when there is a spike in measured temperature of an ultrasonic blade, for

example, of end effector (80) of instrument (50). Such a spike may indicate that the seal of tissue (90) severed by end effector (80) is complete and the blade is contacting a clamp pad or clamp arm that has pivoted toward the blade. Instructions (404) displayed in instruction display box (408) of surgical monitor (400) enable a surgeon to receive real-time feedback during the procedure regarding the status of the utilized surgical instruments, such as instrument (50), without having to look away from the surgical site presented on screen (406) of surgical monitor (400).

[0033] B. Exemplary Safety Glasses

[0034] FIG. 5 shows a version of exemplary safety glasses (416) that may be worn by a surgeon during a surgical procedure while using medical device (10, 100), for example. In use, wireless communications board (418) housed in exemplary surgical instrument (50) may communicate with wireless port (420) on safety glasses (416). Exemplary surgical instrument (50) is a battery-operated device, though instrument (50) could be powered by a cable or otherwise. Instrument (50) includes end effector (80), similar to end effector (16, 140) of medical device (10, 100) described above. Particularly, wireless communications board (418) transmits one or more wireless signals indicated by arrows (B, C) to wireless port (420) of safety glasses (416). Safety glasses (416) receive the signal, analyze the received signal, and display indicated status information received by the signal on lenses (422) to a user, such as surgeon (424), wearing safety glasses (416). Additionally or alternatively, wireless communications board (418) transmits a wireless signal to surgical monitor (400) such that surgical monitor (400) may display received indicated status information to surgeon (424), as described above.

[0035] A version of safety glasses (416A) shown in FIG. 6 includes lighting device (426) on peripheral edges (428) of safety glasses (416A). Lighting device (426) provides peripheral-vision sensory feedback of instrument (50), with which safety glasses (416A) communicate as described below, to a user wearing safety glasses (416A). Lighting device (426) may be, for example, a light-emitted diode (“LED”), a series of LEDs, or any other suitable lighting device known to those of ordinary skill in the art and apparent in view of the teachings herein.

[0036] LEDs may be located at edges or sides of a front lens of safety glasses (416A) so not to distract from a user's center of vision while still being positioned within the user's field of view such that the user does not need to look away from the surgical site to see lighting device (426). Displayed lights may pulse and/or change color to communicate to the wearer of safety glasses (416A) various aspects of information retrieved from instrument (50), such as system status information or tissue sensing information (i.e., whether end effector (80) has sufficiently severed and sealed tissue (90)). Feedback from housed wireless communications board (418) may cause lighting device (426) to activate, blink, or change color to indicate information about the use of instrument (50) to a user. For example, a device may incorporate a feedback mechanism based on one or more sensed tissue parameters. In this case, a change in the device output(s) based on this feedback in synch with a tone change may submit a signal through wireless communications board (418) to safety glasses (416A) to trigger activation of lighting device (426). Such described means of activation of lighting device (426) should not be considered limiting as other means of indicating status information of instrument (50) to the user via safety glasses (416, 416A) are contemplated. Further, safety glasses (416A), as with other versions of safety glasses (416), may be single-use or reusable eyewear. Button-cell power supplies such as button-cell batteries may be used to power wireless receivers and LEDs of versions of safety glasses (416), which may also include a housed wireless board and tri-color LEDs. Such button-cell power supplies may provide a low-cost means of providing sensory feedback of information about instrument (50) when in use to surgeon (424) wearing safety glasses (416).

[0037] FIG. 7 shows a version of safety glasses (416B) including lenses (422B) with edges (428) and surface modification (430). Surface modification (430) assists to "light pipe" the light from lighting device (426), as described above, to improve the ability of a user such as a surgeon to see the indicated status information. Light-piped gradual fade dots (432) positioned on edges (428) of lenses (422B) glow in a user's peripheral vision and then fade away towards the center of the user's vision when the user is wearing safety glasses (416B). LEDs may be disposed behind lenses (422) such that dots (432) may provide discrete points of light off to a side of lenses (422B), transmitting light from the LEDs. Thus, such LEDs may also or alternatively create subtle glowing light, fading

light, and/or patterns of light through use of light piping, for example, and through customized surface finishing and geometry of clear lenses (422B). Use of frosted and polished sections of safety glasses (416B) may create a fade and/or soft-glow effect that may be noticeable to a wearer of safety glasses (416B) without being distracting to the wearer. Dots (432) may provide a color morph (changing color) to indicate an approaching overload of power to instrument (50). For example, color may change from a safe green, to a warning yellow, to an overload status indicator orange. Additionally or alternatively, a pulsing green light may indicate power activation of instrument (50). Further, a yellow and/or orange may indicate a cause for alarm to the user. Other information that may activate dots (432) to display a change in status includes, but is not limited to, AUT condition, a tone of the device, a cycle completion status, a power activation status, a danger of overload of power status, battery life status, and the need for an alarm for other potentially dangerous status changes and received generator information. Safety glasses (416B), as well as other versions of safety glasses (416) may additionally include a piezoelectrical speaker to provide audio feedback to a wearer. Additionally, if there is no generator in the operating room, information may still be displayed for battery-operated devices used in the operating room on versions of safety glasses (416). In other words, safety glasses (416) can receive information from generator (410) and/or directly from instrument (50).

[0038] FIG. 8 shows exemplary safety glasses (416C). Safety glasses (416C) may communicate and be used in conjunction with surgical monitor (400) to provide additional feedback to a user. Safety glasses (416C) may have a transparent color liquid crystal display (“LCD”) overlay (434). LCD overlay (434) may display information to surgeon (424) as a customizable display showing pertinent information about medical device (10) such as, but not limited to, battery life, activation level status, a nerve monitoring alarm threshold indicator, and augmented tissue heat sensor information to display temperature of tissue during the procedure. For example, infrared views may appear in safety glasses (416C) as temperature of end effector (80) increases when end effector (80) is in use. The view may cause end effector (80) reflected in safety glasses (416C) as overlaid display (82), described below, to appear to turn red as temperature

increases while surrounding tissue may appear to surgeon (424) wearing safety glasses (416C) to change color as well based on the temperature of the tissue.

[0039] Transponder (436) on safety glasses (416C) may be positioned on a frame arm (not shown) of safety glasses (416C), and the frame arm may house the battery and all communication systems for receipt of information from instrument (50). Transponder (436) transmits a first signal, indicated by arrow (D), which is picked up by detector (438) (FIG. 1) on surgical monitor (400). This first signal provides information on, for example, the position and orientation of safety glasses (416C). In effect, the first signal informs detector (438) on surgical monitor (400) the direction of the line of sight of surgeon (424), or rather where surgeon (424) is looking. Such information may be gathered using one or more accelerometers and/or various other types of components as will be apparent to those of ordinary skill in the art in view of the teachings herein.

[0040] Based on this orientation information and information received from an electronics module housed in medical device (10, 50, 100), for example, while submitting real-time information about instrument (50) to surgeon (424), detector (438) relays a second signal indicated by arrow (E) to transponder (436) on safety glasses (416C). The second signal causes safety glasses (416C) to display graphics on LCD overlay (434) that provide additional information to a user. For instance, based on information an electronics module housed in instrument (50) receives from end effector (80) when in use, LCD overlay (434) on safety glasses (416) may add color over an area of the vision of surgeon (424) that corresponds to end effector (80) displayed on surgical monitor (400) to indicate a temperature of end effector (80). Such an area of vision encompassing end effector (80) in use is reflected on LCD overlay (434) on safety glasses (416) to show, as FIG. 8 shows, an overlaid display (82) of end effector (80).

[0041] In use, as surgeon (424) looks through safety glasses (416C) at the ongoing procedure, surgeon (424) would see a clear view until surgeon (424) start to use instrument (50). As surgeon (424) begins to activate instrument (50), a sensor within instrument (50) transmits information such as blade temperature to safety glasses (416C). Activation of instrument (50) activates overlay (434). As surgeon (424) looks at end

effector (80) on surgical monitor (400) and/or within safety glasses (416C), surgeon (424) may begin to see an infrared overlay change the color of end effector (80), or rather overlaid display (82) of end effector (80), and adjacent tissue from a normal color to an orange and then red color, for example, as the temperature of end effector (80) and/or tissue (90) increases. Such visualized information gives surgeon (424) real-time feedback as to tissue temperature and thermal spread of instrument (50) being used, for example.

[0042] It should be understood that any one or more of the teachings, expressions, embodiments, examples, etc. described herein may be combined with any one or more of the other teachings, expressions, embodiments, examples, etc. that are described herein. The following-described teachings, expressions, embodiments, examples, etc. should therefore not be viewed in isolation relative to each other. Various suitable ways in which the teachings herein may be combined will be readily apparent to those of ordinary skill in the art in view of the teachings herein. Such modifications and variations are intended to be included within the scope of the claims.

[0043] Versions of the devices described above may have application in conventional medical treatments and procedures conducted by a medical professional, as well as application in robotic-assisted medical treatments and procedures.

[0044] Versions of described above may be designed to be disposed of after a single use, or they can be designed to be used multiple times. Versions may, in either or both cases, be reconditioned for reuse after at least one use. Reconditioning may include any combination of the steps of disassembly of the device, followed by cleaning or replacement of particular pieces, and subsequent reassembly. In particular, some versions of the device may be disassembled, and any number of the particular pieces or parts of the device may be selectively replaced or removed in any combination. Upon cleaning and/or replacement of particular parts, some versions of the device may be reassembled for subsequent use either at a reconditioning facility, or by a user immediately prior to a procedure. Those skilled in the art will appreciate that reconditioning of a device may utilize a variety of techniques for disassembly,

cleaning/replacement, and reassembly. Use of such techniques, and the resulting reconditioned device, are all within the scope of the present application.

[0045] By way of example only, versions described herein may be sterilized before and/or after a procedure. In one sterilization technique, the device is placed in a closed and sealed container, such as a plastic or TYVEK bag. The container and device may then be placed in a field of radiation that can penetrate the container, such as gamma radiation, x-rays, or high-energy electrons. The radiation may kill bacteria on the device and in the container. The sterilized device may then be stored in the sterile container for later use. A device may also be sterilized using any other technique known in the art, including but not limited to beta or gamma radiation, ethylene oxide, or steam.

[0046] Having shown and described various versions in the present disclosure, further adaptations of the methods and systems described herein may be accomplished by appropriate modifications by one of ordinary skill in the art without departing from the scope of the present invention. Several of such potential modifications have been mentioned, and others will be apparent to those skilled in the art. For instance, the examples, versions, geometrics, materials, dimensions, ratios, steps, and the like discussed above are illustrative and are not required. Accordingly, the scope of the present invention should be considered in terms of the following claims and is understood not to be limited to the details of structure and operation shown and described in the specification and drawings.

I/We claim:

1. A surgical system comprising:
 - (a) a surgical instrument comprising:
 - i. a body,
 - ii. a shaft extending from the body, and
 - iii. an end effector at a distal end of the shaft; and
 - (b) a transmitter configured to wirelessly transmit a signal associated with the end effector.
2. The surgical system of claim 1, further comprising a set of safety glasses comprising a wireless port, wherein the wireless port is configured to receive the signal from the transmitter.
3. The surgical system of claim 2, further comprising a surgical monitor, wherein the safety glasses are configured to project the signal to the surgical monitor.
4. The surgical system of claim 3, wherein the safety glasses comprise one or more LEDs, wherein the LEDs are configured to be positioned within a user's peripheral field of vision when the user is wearing the safety glasses and viewing the surgical monitor such that the LEDs do not restrict user vision of the surgical monitor and such that both the surgical monitor and the LEDs are simultaneously viewable to the user.
5. The surgical system of claim 2, wherein the safety glasses comprise a front lens and a pair of lighting devices, wherein each lighting device is disposed on a respective peripheral edge of the lens.
6. The surgical system of claim 5, wherein the lighting devices comprise one or more LEDs.

7. The surgical system of claim 6, wherein the LEDs are tri-colored.
8. The surgical system of claim 6, wherein the one or more LEDs are configured to one or both of:
 - (i) display a pulsing light based on the received signal, or
 - (ii) change color based on the received signal.
9. The surgical system of claim 2, wherein an overlaid display of the end effector is positioned on the safety glasses when worn by a surgeon using the end effector of the surgical instrument during a surgical procedure.
10. The surgical system of claim 9, wherein the overlaid display is configured to change color to indicate a change in end effector temperature status based on the received signal.
11. The surgical system of claim 2, wherein the safety glasses comprise at least one lighting device and a front lens including a surface modification configured to pipe light from the lighting device, wherein the surface modification is disposed on a peripheral edge of the lens.
12. The surgical system of claim 11, wherein the at least one lighting device comprises a pair of lighting devices, wherein each lighting device is disposed on a respective peripheral edge of the lens.
13. The surgical system of claim 11, wherein the at least one lighting device comprises an LED.
14. The surgical system of claim 11, wherein the surface modification comprises a series of dots configured to emit discrete points of light.
15. The surgical system of claim 11, wherein the dots are configured to emit at least

one of a glow, a fade, or a pattern of light.

16. A system for transmitting information, the system comprising:
- (a) a surgical instrument comprising:
 - i. a body,
 - ii. a shaft extending from the body, and
 - iii. an end effector at a distal end of the shaft;
 - (b) a first wireless transmitter configured to transmit a first signal associated with the end effector;
 - (c) a generator configured to receive information from the first wireless transmitter;
 - (d) a second wireless transmitter, wherein the second wireless transmitter is associated with the generator, wherein the second wireless transmitter is configured to send a second signal;
 - (e) a procedure monitoring system,
 - (f) a third wireless transmitter, wherein the third wireless transmitter is associated with the procedure monitoring system, wherein the third wireless transmitter is configured to receive the second signal from the second wireless transmitter, wherein the third wireless transmitter is configured to send a third signal; and
 - (g) a surgical monitor including a detector configured to receive the third signal from the third wireless transmitter to generate a display on the surgical monitor indicating information about the surgical instrument.
17. The system of claim 16, wherein the indicated information relates to the temperature of the end effector when the surgical instrument is in use.
18. The system of claim 16, wherein the surgical instrument comprises one of an ultrasonic surgical instrument or an RF electrosurgical instrument.
19. A method of presenting information regarding a surgical instrument, the surgical

instrument including a body, a shaft extending from the body, and an end effector at a distal end of the shaft, the method comprising:

- (a) associating a first wireless transmitter with the end effector;
- (b) transmitting a signal via the first wireless transmitter;
- (c) receiving the signal via a detector of a surgical monitor; and
- (d) generating a display on the surgical monitor indicating information about the surgical instrument, wherein the display is based at least in part on the signal transmitted via the first wireless transmitter.

20. The method of claim 20, wherein the step of transmitting a signal via the first wireless transmitter comprises:

- (i) transmitting a first signal via the first wireless transmitter,
- (ii) receiving the first signal via a second wireless transmitter of a generator,
- (iii) transmitting a second signal via the second wireless transmitter,
- (iv) receiving the second signal via a third wireless transmitter of a procedure monitoring system, and
- (v) transmitting a third signal via the third wireless transmitter to the detector of a surgical monitor,

wherein the step of receiving the signal via a detector of a surgical monitor comprises receiving the third signal.

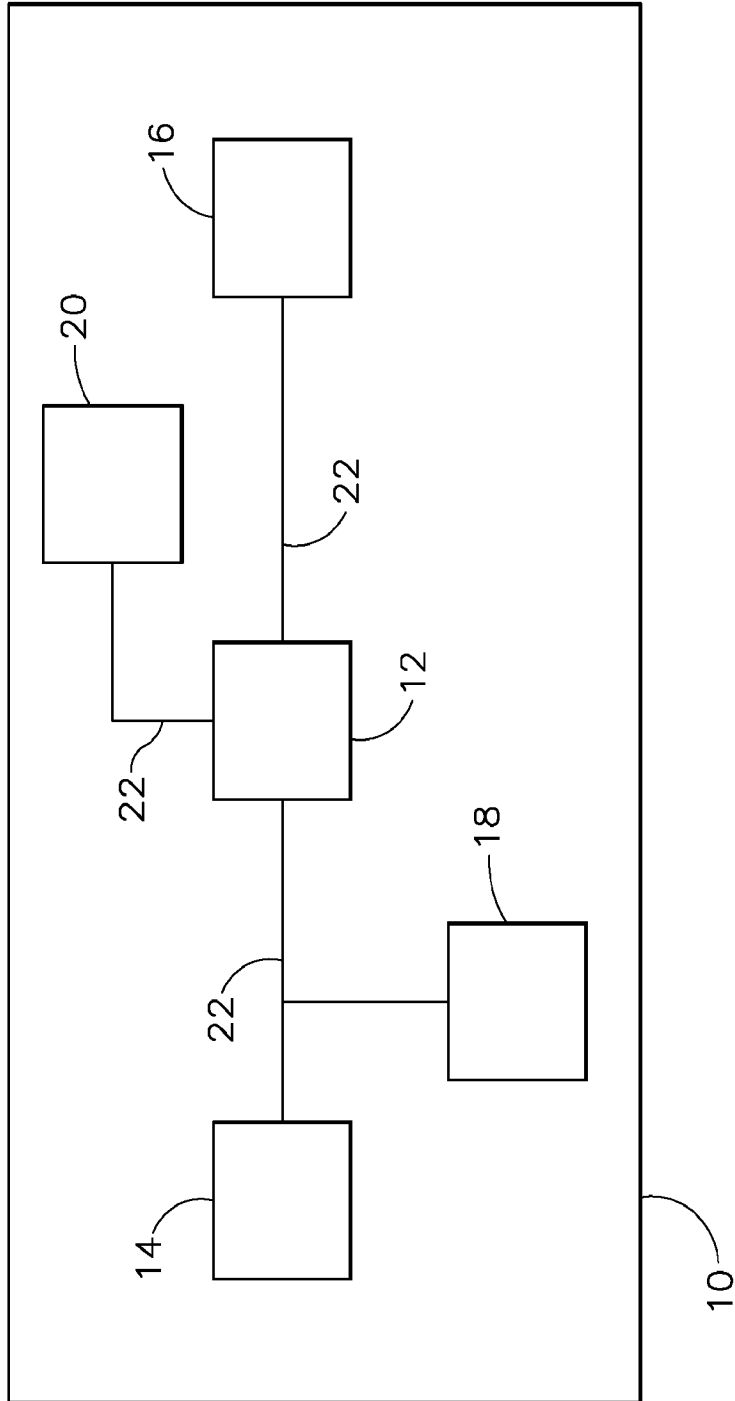

Fig. 1

2/6

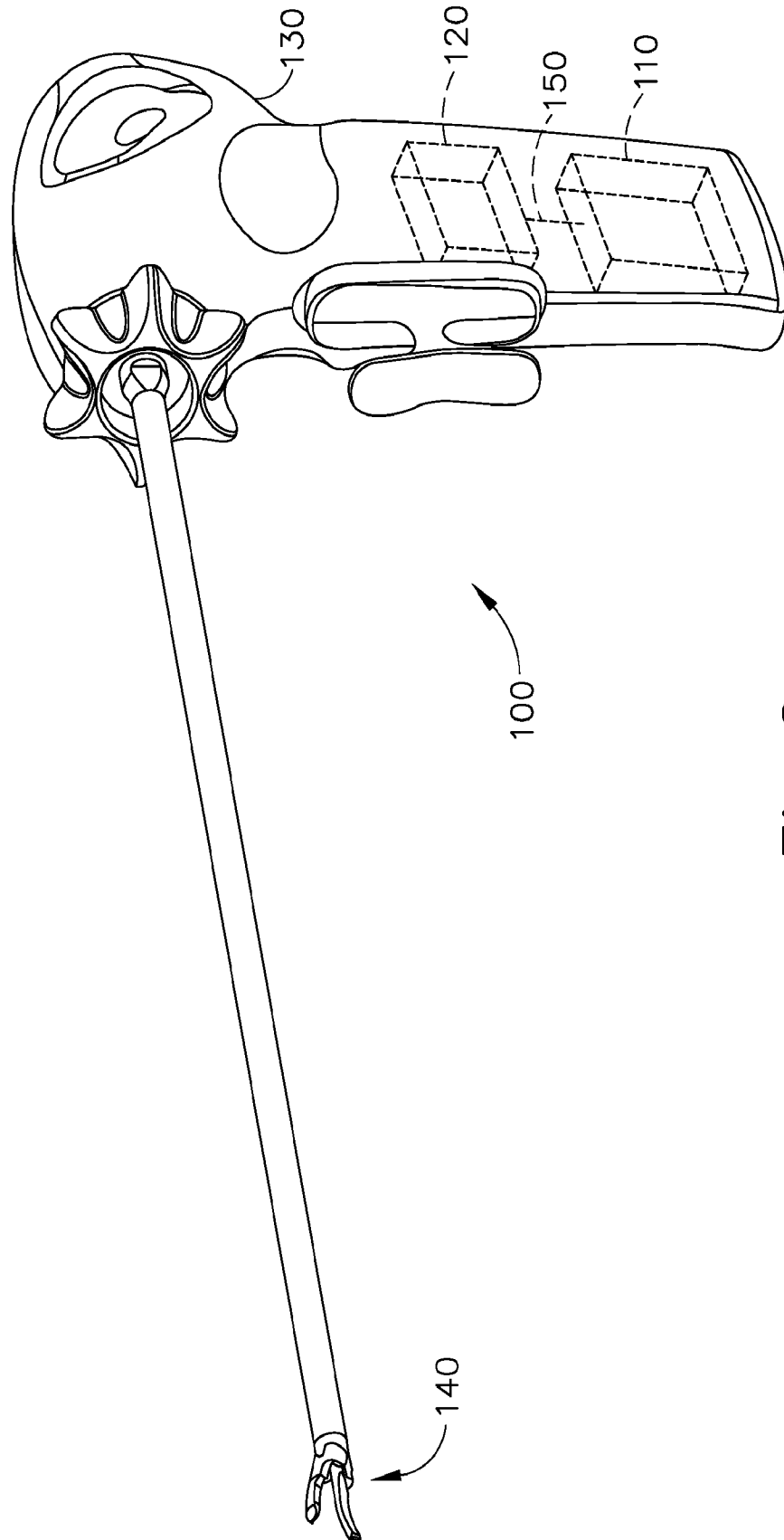

Fig.2

3/6

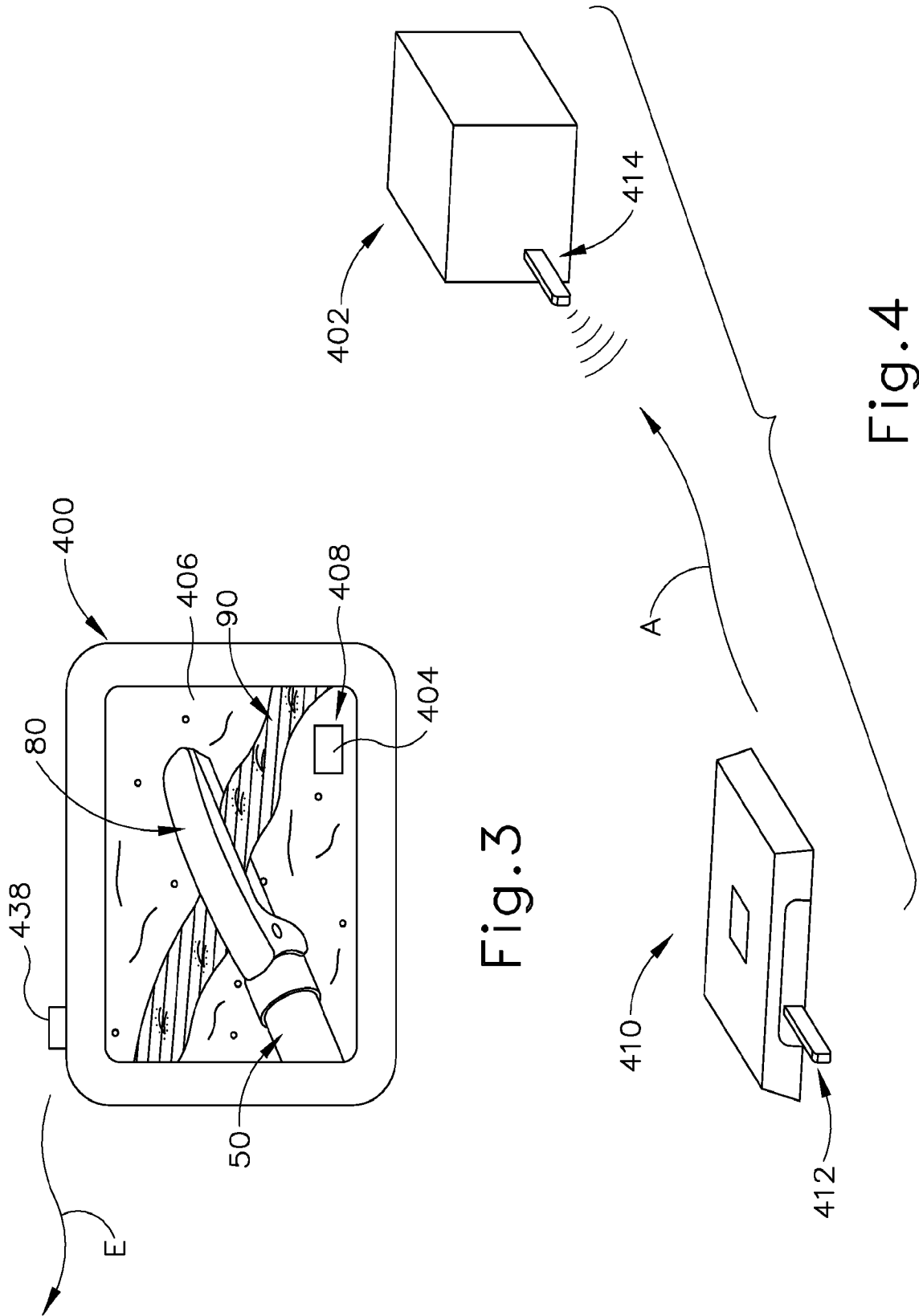

Fig. 4

Fig. 3

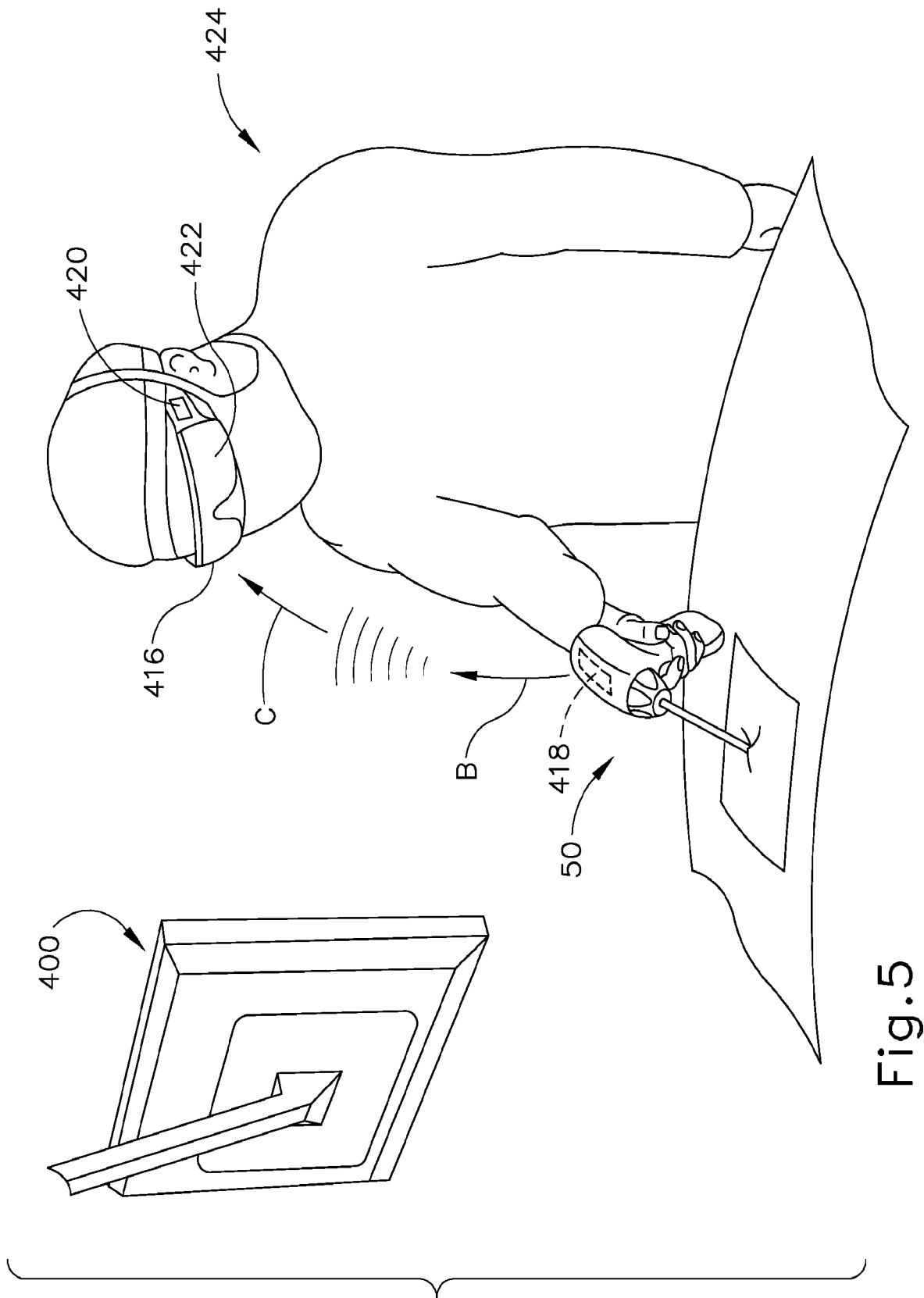

Fig. 5

5/6

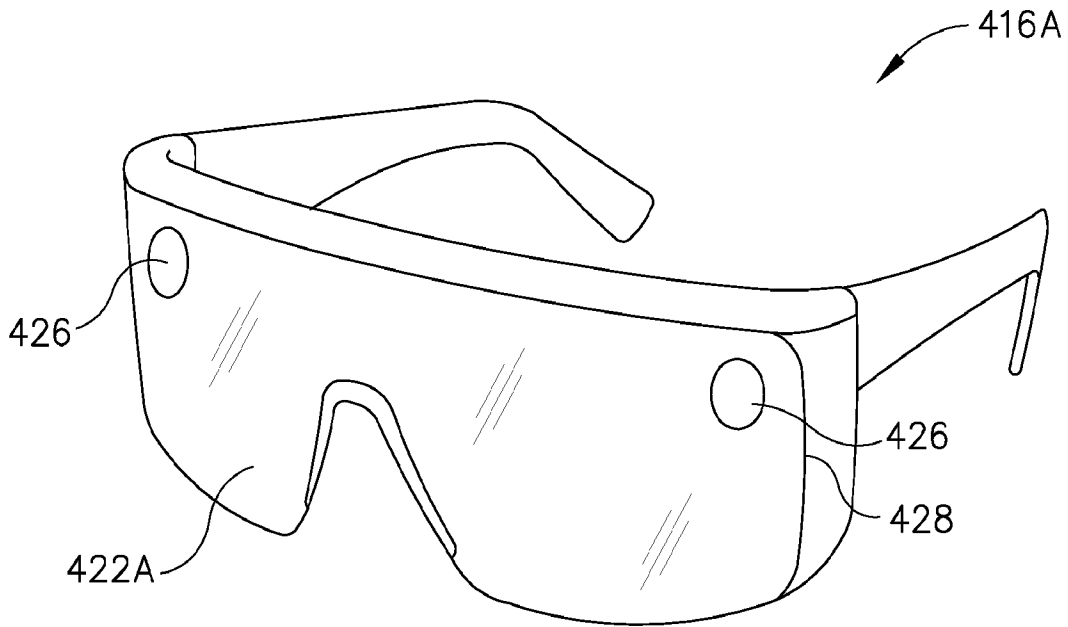

Fig. 6

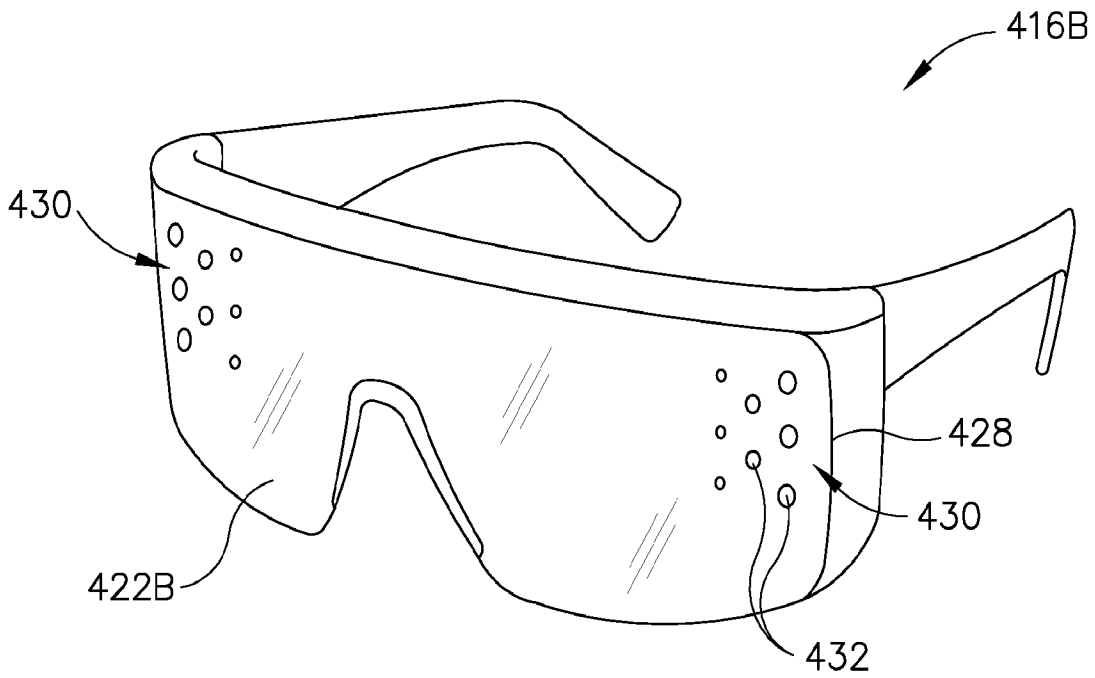

Fig. 7

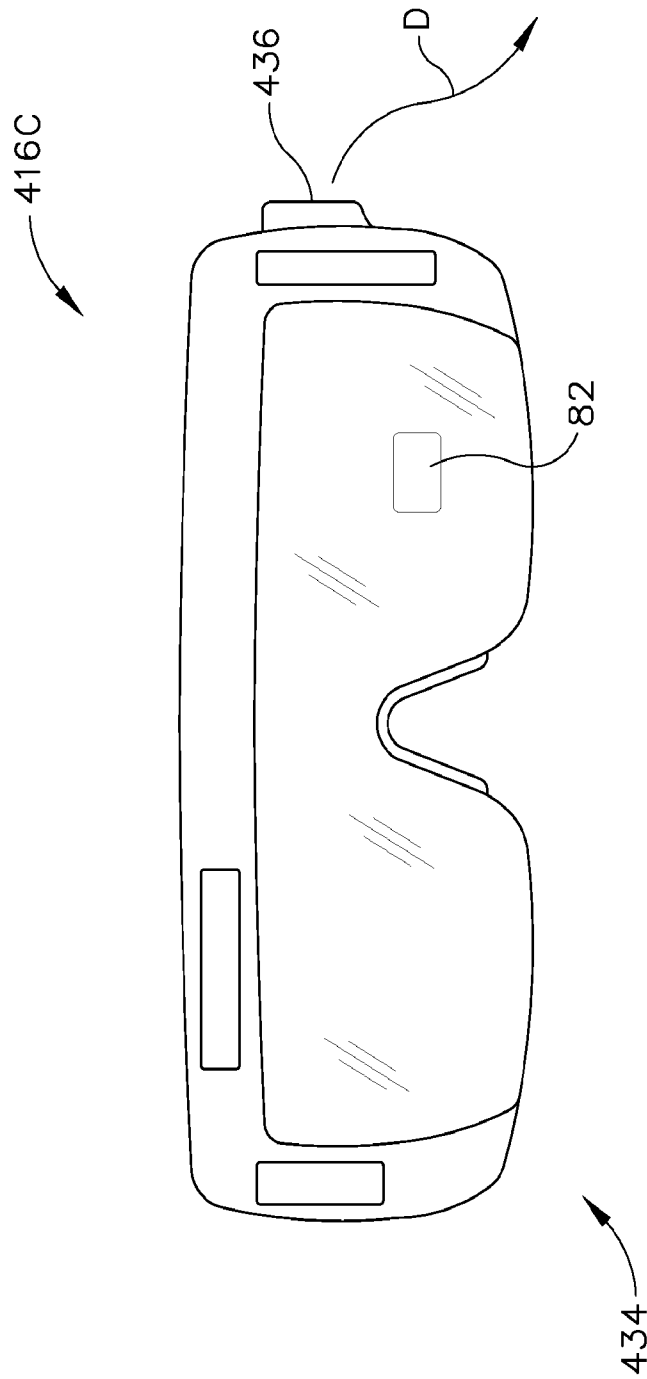

Fig. 8