



US 20060024634A1

(19) **United States**

(12) **Patent Application Publication**

**Lai et al.**

(10) **Pub. No.: US 2006/0024634 A1**

(43) **Pub. Date: Feb. 2, 2006**

(54) **SELF-LIGATING ORTHODONTIC APPLIANCE WITH CLIP**

**Publication Classification**

(75) Inventors: **Ming-Lai Lai**, Arcadia, CA (US);  
**Jirina V. Pospisil**, Hacienda Heights, CA (US);  
**Hoang V. Nguyen**, Garden Grove, CA (US)

(51) **Int. Cl.**  
**A61C 3/00** (2006.01)  
(52) **U.S. Cl.** ..... **433/11**

Correspondence Address:  
**3M INNOVATIVE PROPERTIES COMPANY**  
**PO BOX 33427**  
**ST. PAUL, MN 55133-3427 (US)**

(57) **ABSTRACT**

An orthodontic appliance includes a latch that comprises at least one clip with a region for receiving an archwire. The clip also includes a recess for receiving a post of the appliance and for coupling the clip to remaining components of the appliance. The clip includes at least one protrusion that extends between the post-receiving recess and the archwire-receiving region, and the protrusion serves to retain the clip in place on the post.

(73) Assignee: **3M Innovative Properties Company**

(21) Appl. No.: **10/900,779**

(22) Filed: **Jul. 28, 2004**

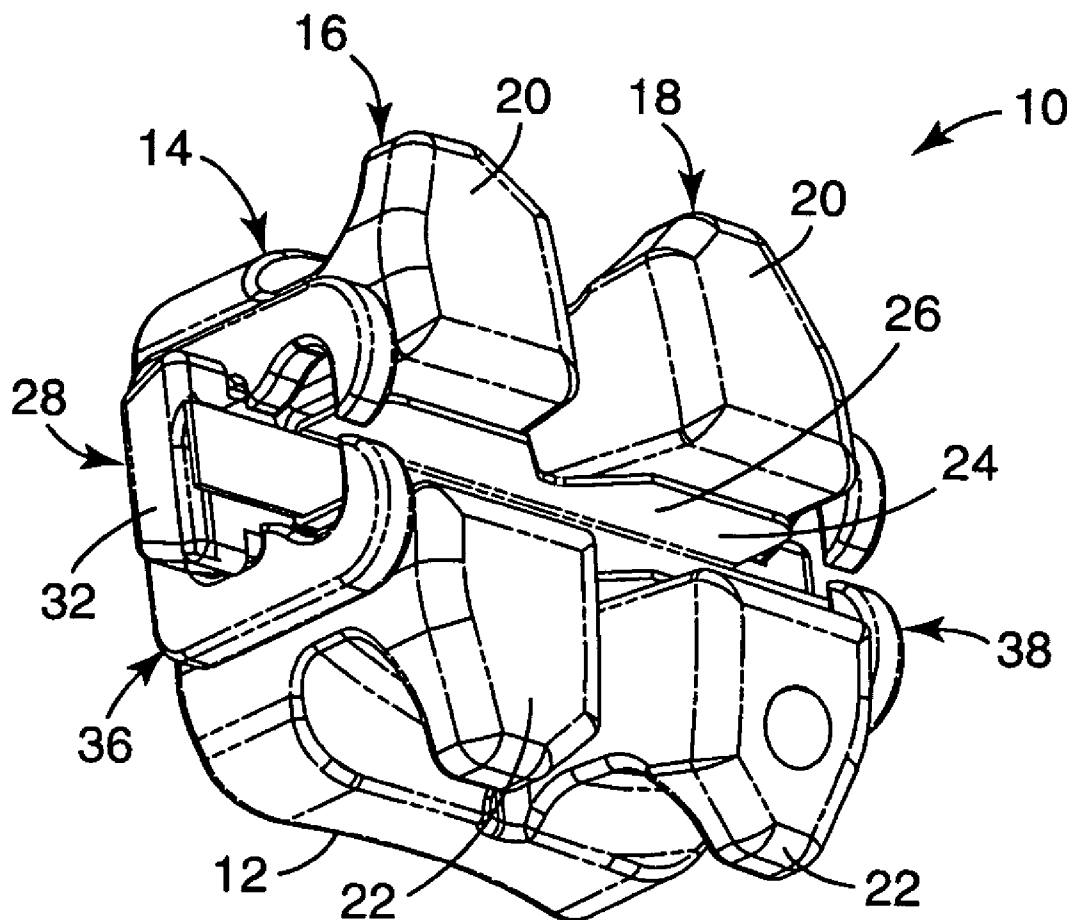

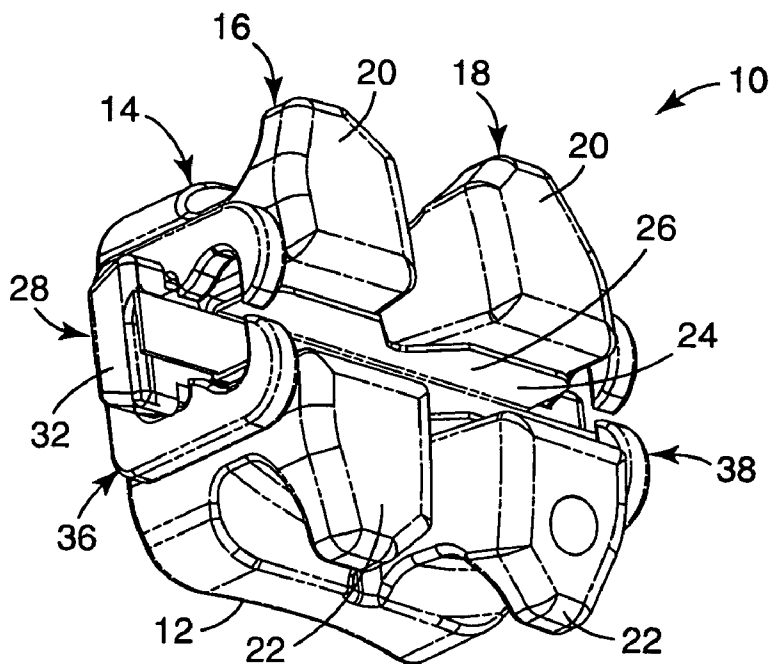

Fig. 1

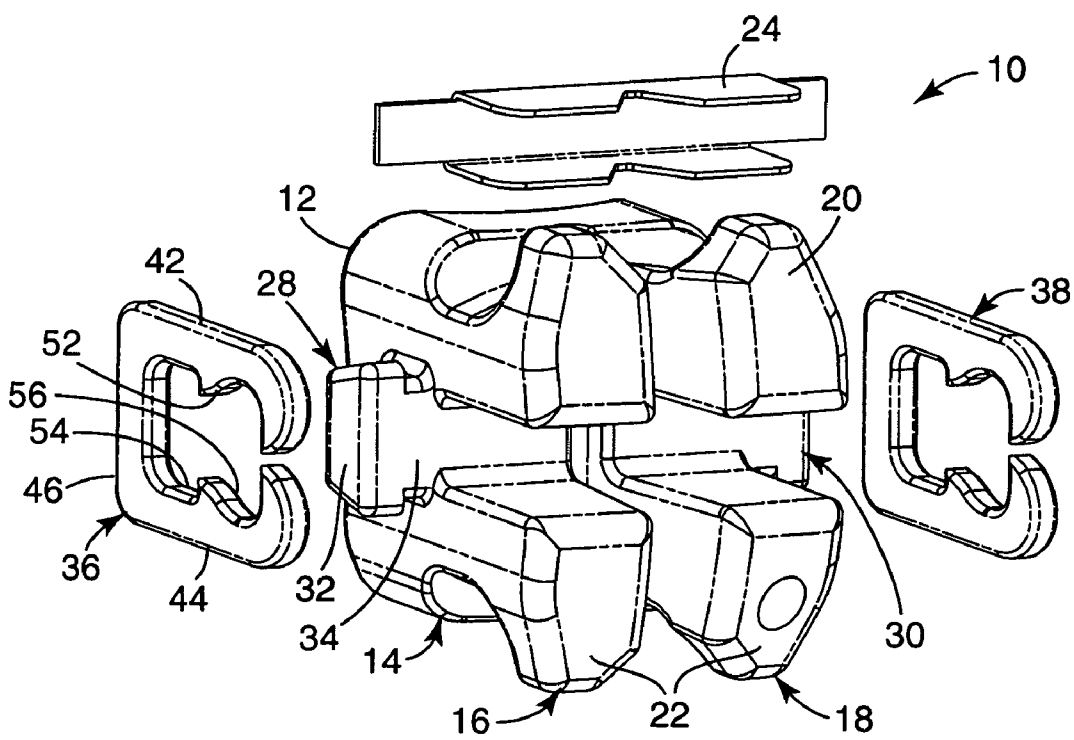
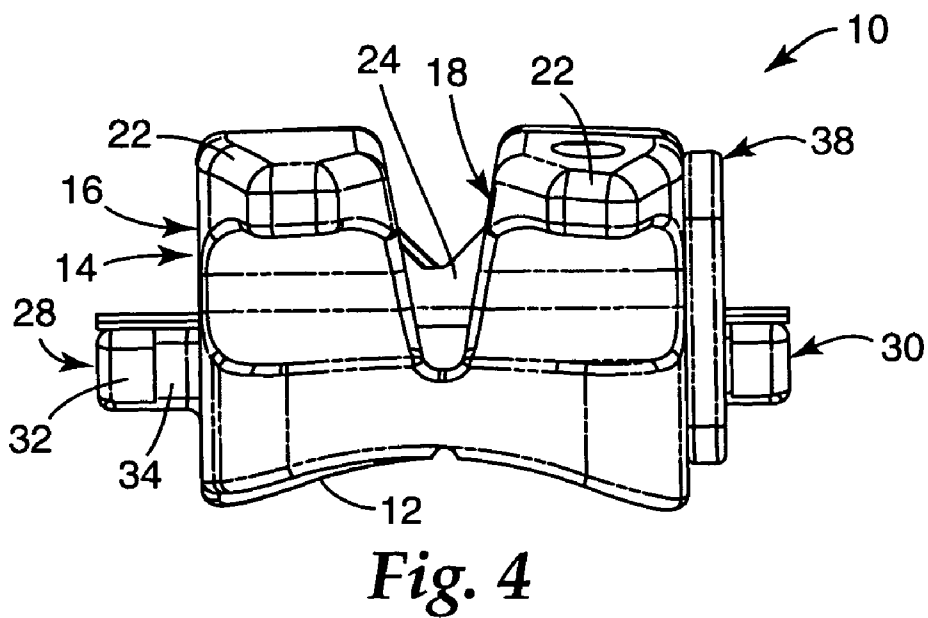
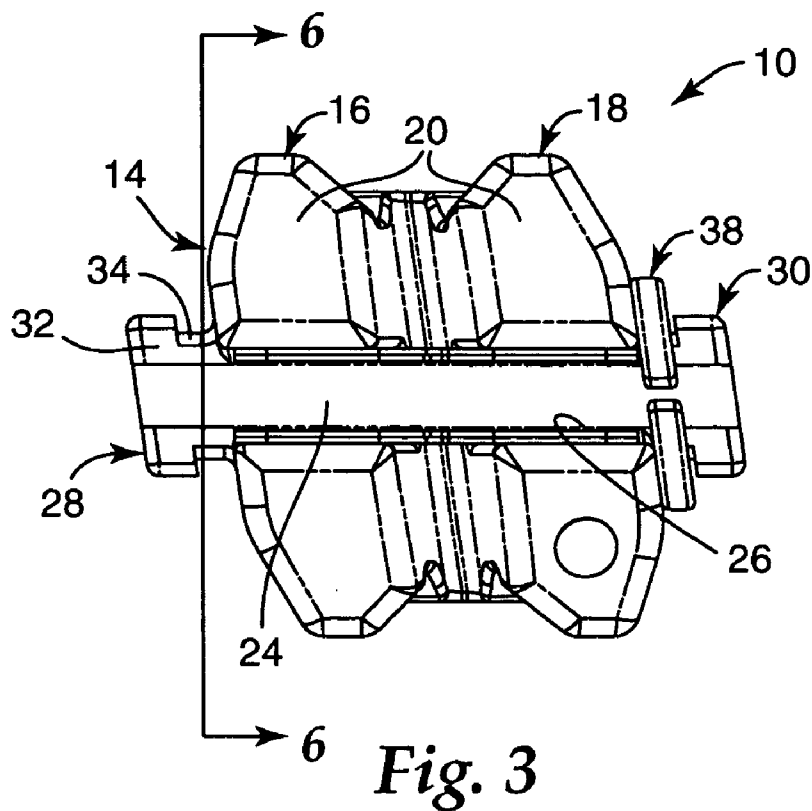
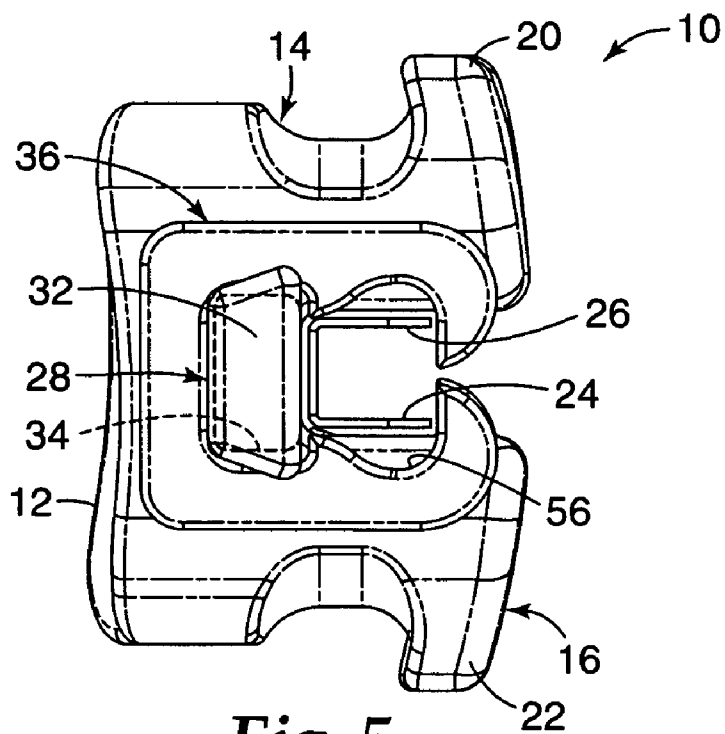
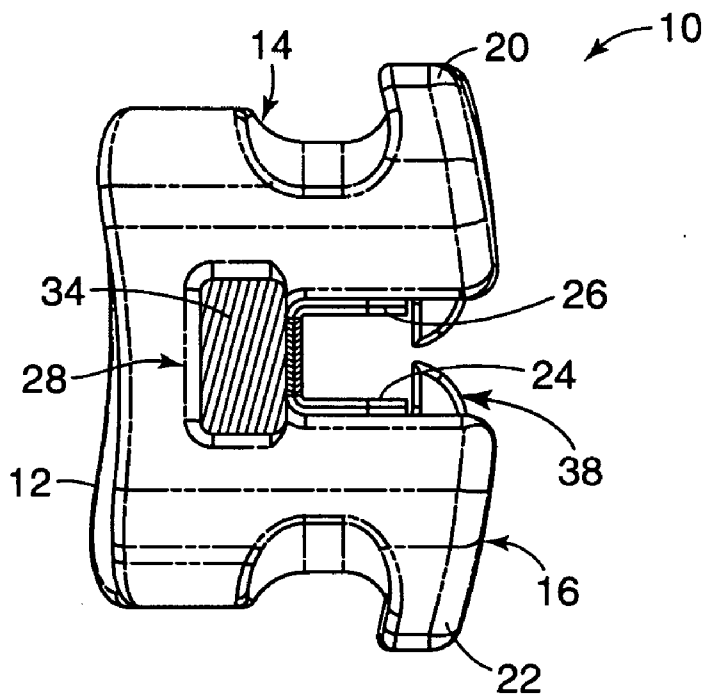

Fig. 2

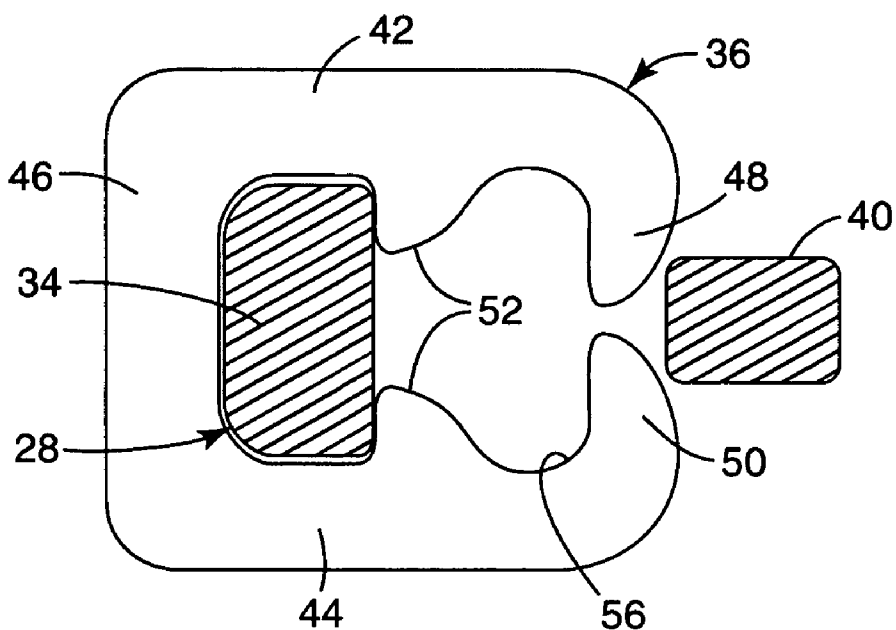



**Fig. 5**



**Fig. 6**



*Fig. 7*

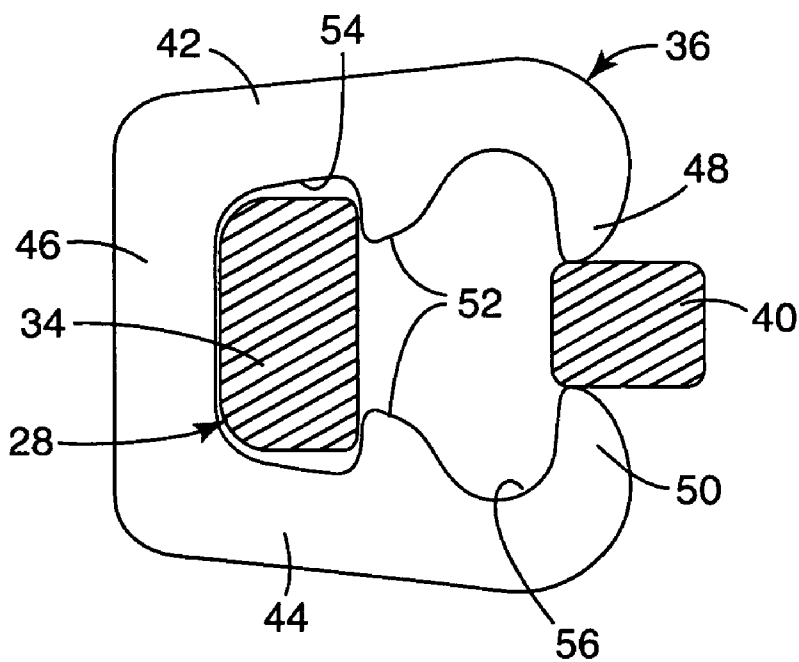

*Fig. 8*

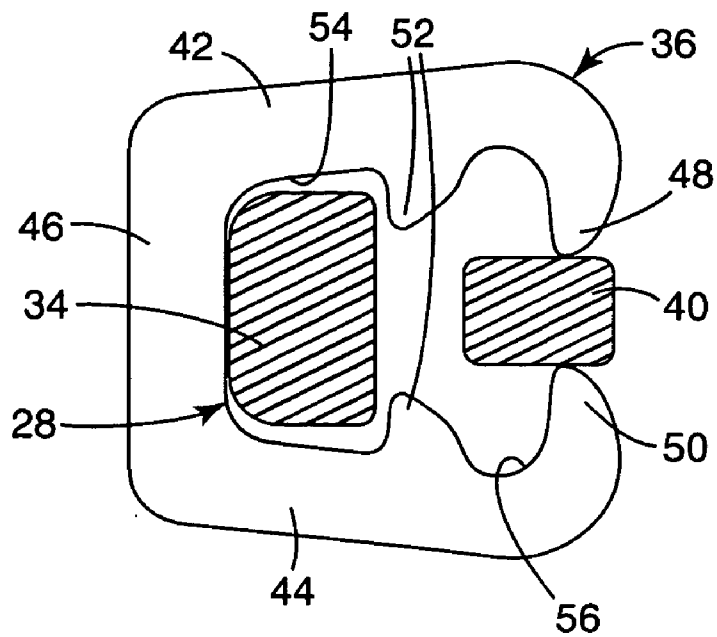

**Fig. 9**

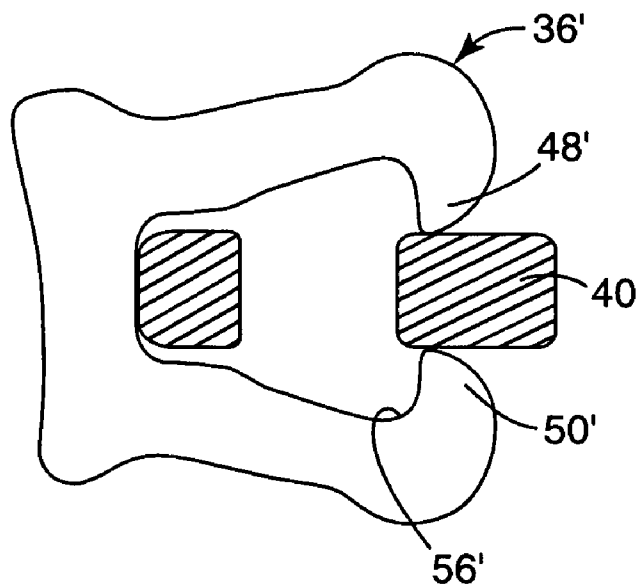

**Fig. 10**  
Prior Art

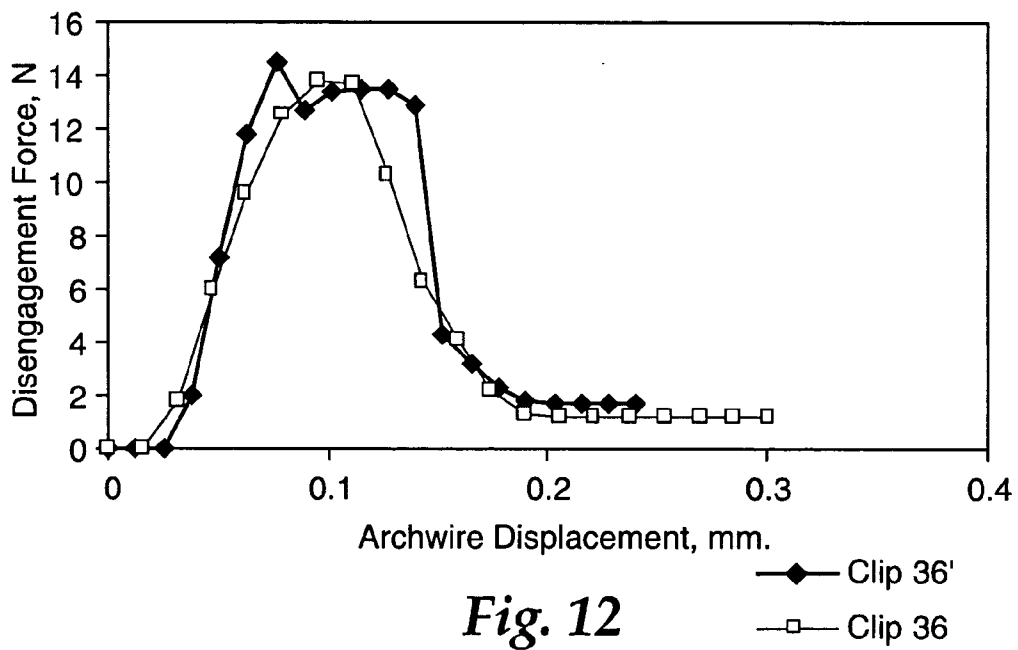
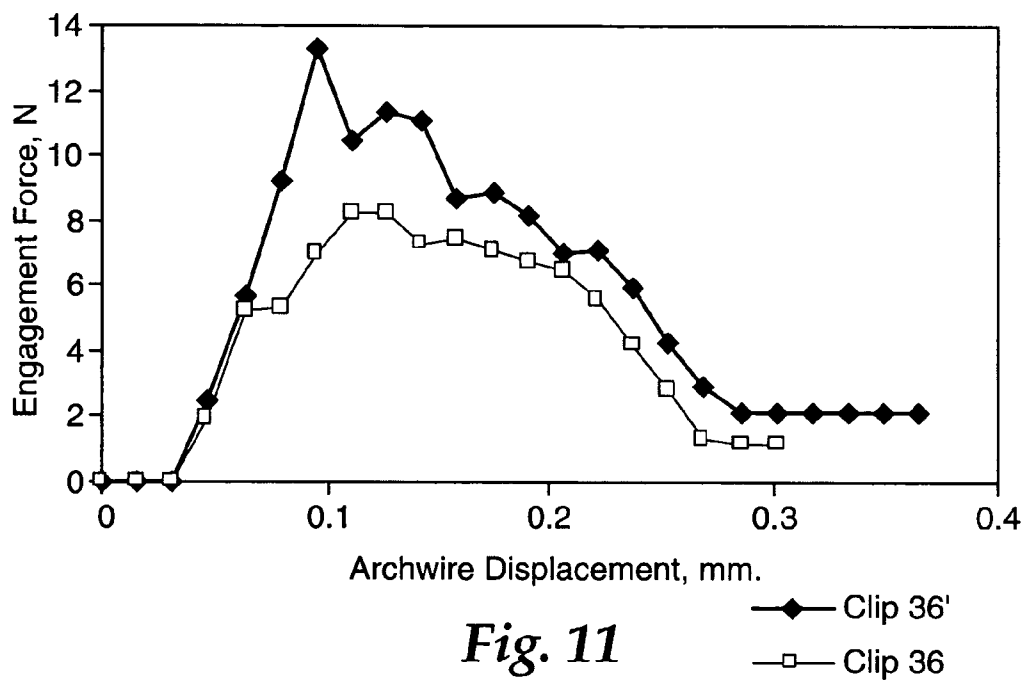

**SELF-LIGATING ORTHODONTIC APPLIANCE WITH CLIP**

**BACKGROUND OF THE INVENTION**

**[0001]** 1. Field of the Invention

**[0002]** This invention broadly relates to appliances that are used in the course of orthodontic treatment. More particularly, the present invention relates to a self-ligating orthodontic appliance such as a bracket or molar appliance having a latch that releasably retains an archwire in an archwire slot of the appliance.

**[0003]** 2. Description of the Related Art

**[0004]** Orthodontic therapy is a specialized type of treatment within the field of dentistry, and involves movement of malpositioned teeth to orthodontically correct locations. Orthodontic treatment typically enhances the aesthetic appearance of the teeth, particularly in instances when the patient's front teeth are malpositioned or crooked. Orthodontic treatment can also improve the patient's occlusion so that the teeth function better with each other during mastication.

**[0005]** Many types of orthodontic treatment programs involve the use of a set of tiny appliances and wires that are commonly known collectively as "braces". During such treatment programs, small slotted appliances known as brackets are fixed to the patient's anterior, cuspid and bicuspid teeth, and an archwire is inserted into the slot of each bracket. The archwire forms a track to guide movement of the teeth to orthodontically correct locations. End sections of the archwires are typically captured in molar appliances that are fixed to the patient's molar teeth.

**[0006]** Recently, there has been increased interest in orthodontic appliances that have a latch for retaining the archwire in the archwire slot. Appliances of this type are widely known as self-ligating appliances and often obviate the need to use ligatures (such as wire ties or elastomeric O-rings) for retaining the archwire in the archwire slots. Improved self-ligating orthodontic appliances having a self-releasing latch are described in applicant's U.S. Pat. Nos. 6,302,688 and 6,582,226.

**[0007]** A recently introduced self-ligating appliance known as "SMARTCLIP" brand appliance from 3M Unitek Corporation has a latch that comprises two resilient clips, and each clip has a generally "C"-shaped configuration. The clips spread open to admit an archwire into an archwire slot of the appliance. Each clip is connected to a body of the appliance by a post that extends through the clip, and an outwardly extending base of the appliance helps to retain the clip in place on the post.

**SUMMARY OF THE INVENTION**

**[0008]** The present invention is directed toward a self-ligating orthodontic appliance having a latch that includes at least one clip. Each clip is connected to remaining components of the appliance by a post that extends through a recess of the clip. Each clip also has at least one protrusion that extends along a side of the post for retaining the clip in place.

**[0009]** In more detail, the present invention is directed in one aspect to an orthodontic appliance that comprises a base,

a body extending outwardly from the base and an archwire slot extending across the appliance in a generally mesial-distal direction. The appliance also includes a post extending outwardly from the body, and a latch for releasably retaining an archwire in the archwire slot. The latch comprises a clip with a region next to the archwire slot for receiving the archwire. The clip also includes a recess that receives the post, and the recess is in communication with the archwire-receiving region. The post includes a side that faces the region. The clip also includes at least one protrusion that extends along the side of the post between the region and the recess.

**[0010]** Another aspect of the present invention is also directed toward an orthodontic appliance that comprises a base, a body extending outwardly from the base and an archwire slot extending across the appliance in a generally mesial-distal direction. The appliance further comprises a post extending outwardly from the body and a latch for releasably retaining an archwire in the archwire slot. The latch comprises a clip with a region next to the archwire slot for receiving an archwire. The clip also includes a recess that receives the post, and the recess is in communication with the archwire-receiving region. The post includes a side that faces the region. The clip also includes two protrusions that extend in opposite directions toward each other along the side of the post.

**[0011]** Advantageously, it has been found that the clip of the present invention enables the archwire to be inserted into the archwire-receiving region with less force than might be otherwise expected. Consequently, the practitioner is able to ligate the archwire to the appliance with less force and as a result the procedure is less painful to the patient. This feature is particularly important for patients with teeth that are somewhat mobile due to previous orthodontic therapy since those teeth are known to be more sensitive to pain caused by the pressure of external forces. Additional aspects and features of the invention are set out in the detailed description that follows and are illustrated in the accompanying drawings.

**BRIEF DESCRIPTION OF THE DRAWINGS**

**[0012]** FIG. 1 is a perspective view of an orthodontic appliance constructed in accordance with one embodiment of the present invention, looking at the appliance toward its mesial, buccolabial and gingival sides;

**[0013]** FIG. 2 is an exploded perspective view of the appliance depicted in FIG. 1, looking at the appliance toward its mesial, buccolabial and occlusal sides;

**[0014]** FIG. 3 is an assembled, front elevational view of the appliance shown in FIGS. 1 and 2, looking at the appliance toward its buccolabial side, and wherein one clip of the appliance has been omitted for purposes of illustration;

**[0015]** FIG. 4 is a bottom view of the appliance illustrated in FIG. 3, looking at the appliance toward its gingival side;

**[0016]** FIG. 5 is a side elevational view of the appliance shown in FIGS. 1-4, looking at the appliance toward its mesial side and illustrating the clip in place;

**[0017]** FIG. 6 is a side cross-sectional view taken along lines 6-6 of FIG. 3, showing among other things the configuration of a neck of a post of the appliance;



[0018] FIG. 7 is a view of the neck and clip alone, along with an exemplary archwire that is about to be received in an archwire slot of the appliance; and

[0019] FIG. 8 is a view somewhat similar to FIG. 7 except that the clip is shown in an open position as it might appear during insertion of the archwire into the archwire slot;

[0020] FIG. 9 is a view somewhat similar to FIG. 8 except that the clip is shown in an open position as it might appear during release of the archwire from the archwire slot;

[0021] FIG. 10 is a view somewhat similar to FIG. 8 except that a clip of prior art construction is illustrated for purposes of comparison;

[0022] FIG. 11 is a graph depicting the force needed to insert an archwire into an archwire slot of an appliance having the clip shown in FIG. 8, along with the force needed to insert an archwire into an archwire slot of an appliance having the clip shown in FIG. 10; and

[0023] FIG. 12 is a graph somewhat similar to FIG. 11 except that the forces needed to release an archwire from the archwire slot of the appliances are shown.

#### DEFINITIONS

[0024] “Mesial” means in a direction toward the center of the patient’s curved dental arch.

[0025] “Distal” means in a direction away from the center of the patient’s curved dental arch.

[0026] “Occlusal” means in a direction toward the outer tips of the patient’s teeth.

[0027] “Gingival” means in a direction toward the patient’s gums or gingiva.

[0028] “Buccolabial” means in a direction toward the patient’s lips or cheeks.

[0029] “Lingual” means in a direction toward the patient’s tongue.

#### DETAILED DESCRIPTION OF THE PREFERRED EMBODIMENTS

[0030] An orthodontic appliance constructed in accordance with one embodiment of the present invention is illustrated in FIGS. 1-8 and is broadly designated by the numeral 10. The appliance 10 in this instance is an orthodontic bracket that is adapted to be secured to an enamel surface of a patient’s tooth, such as a buccolabial tooth surface. Alternatively, the appliance could be a molar appliance, an appliance for attachment to a lingual tooth surface, or any other appliance that is adapted to receive an archwire for controlling movement of the associated tooth during the course of orthodontic therapy.

[0031] The appliance 10 includes a base 12 for bonding the appliance 10 directly to the patient’s tooth enamel by the use of an adhesive. Preferably, the base 12 has an outwardly facing concave compound contour that matches the convex compound contour of the patient’s tooth surface to which it is bonded. Optionally, the base 12 is provided with grooves, particles, recesses, undercuts, a chemical bond enhancement material or any other material or structure, or any combination of the foregoing that facilitates bonding of the appliance 10 directly to the patient’s tooth surface.

[0032] A body 14 extends outwardly from the base 12 in a generally buccolabial direction. The body 14 includes a mesial body portion 16 and a distal body portion 18 that is spaced from the mesial body portion 16. In this embodiment, each of the portions 16, 18 includes an occlusal tieewing 20 and a gingival tieewing 22, although one or more of the tieewings 20, 22 could be omitted if desired.

[0033] Preferably, and as shown in FIGS. 1-3, the body 14 (including the body portions 16, 18) is integrally connected to the base 12, and the body 14 and the base 12 form a single, unitary component. However, other constructions are also possible. For example, if the base and the body are made of a metallic material, the base could be manufactured separately from the body and later welded or brazed to the body during an assembly operation.

[0034] The appliance 10 also includes an archwire slot liner 24 that is fixed to the body portions 16, 18. The archwire slot liner 24 defines occlusal, gingival and lingual sides of an archwire slot 26. The archwire slot 26 longitudinally extends in a generally mesial-distal direction across the appliance 10, including through a channel of the body portions 16, 18. However, the archwire slot liner 24 is optional and may be omitted. If the archwire slot liner 24 is omitted, the channel of the body portions 16, 18 is made smaller in order to match the cross-sectional area of the archwire and serve as an archwire slot.

[0035] The base 12, the body 14 and the archwire slot liner 24 are preferably similar to the corresponding components of the appliances described in U.S. Pat. Nos. 5,439,379 and 5,366,372. Preferably, the base 12 and the body 14 are made of a transparent monocrystalline ceramic material or a translucent polycrystalline ceramic material such as alumina, and the archwire slot liner 24 is made of a metallic material. Examples of suitable materials and methods for constructing the archwire slot liner 24, as well as suitable methods of attaching the archwire slot liner 24 to the body portions 16, 18 are described in U.S. Pat. Nos. 5,358,402 and 5,380,196.

[0036] Each of the tieewings 20, 22 extends over a recess or notch for receiving a ligature (not shown). However, the provision of the tieewings 20, 22 and the use of a ligature are optional and may only be needed in certain instances, such as in instances where the tooth is severely malpositioned during the initial stages of treatment. Optionally, the tieewings 20, 22 and the ligature-receiving recesses are constructed as set out in applicant’s co-pending U.S. patent application Ser. No. 10/770,779, filed Feb. 3, 2004 and entitled “ORTHODONTIC BRACKET WITH REINFORCED TIEWINGS”.

[0037] The appliance 10 includes a mesial post 28 and a distal post 30 that are integrally connected to the mesial body portion 16 and the distal body portion 18 respectively. The posts 28, 30 extend outwardly in opposite directions away from each other and from the body 14. Preferably, each post 28, 30 extends along a reference axis that is parallel to the longitudinal axis of the archwire slot 26. As shown for example in FIGS. 4-6, the posts 28, 30 are located in a lingual direction relative to the archwire slot 26.

[0038] The mesial post 28 includes an outermost head 32 and a neck 34 that integrally interconnects the head 32 and the mesial body portion 16. As depicted in FIG. 6, the neck

**34** has a generally rectangular cross-sectional configuration when considered in reference planes perpendicular to the reference axis along which the post **28** extends or when considered in reference planes generally perpendicular to a mesial-distal axis. Preferably, the occlusal, gingival and lingual sides of the neck **34** in regions along the innermost or distal end of the neck **34** include curved or chamfered sections that are connected to the mesial side of the mesial body portion **16**, for enhancing the strength of the connection between the mesial post **28** and the body **14**.

[0039] As shown for example in **FIG. 5**, the head **32** of the post **28** has a generally trapezoidal configuration when viewed in a distal direction, or when viewed in reference planes that are perpendicular to the reference axis along which the post **28** extends. **FIG. 5** also illustrates in dashed lines the cross-sectional shape of the neck **34** for purposes of comparison. As illustrated, the height of the neck **34** and the height of the head **32** are essentially the same along the lingual side of the post **28** when considered in directions along an occlusal-lingual reference axis (i.e. along a vertical axis when viewing **FIGS. 5-8**). However, along the buccolabial side of the post **28**, the height of the head **32** is greater than the height of the neck **34** when considered in directions along an occlusal-lingual reference axis.

[0040] The head **32** extends outwardly past the neck **34** a certain distance when considered in reference planes perpendicular to a mesial-distal reference axis or when considered in reference planes perpendicular to the reference axis along which the post **28** extends. In the illustrated embodiment, the head **32** extends outwardly past the neck **34** in at least one, and preferably in both directions along an occlusal-lingual reference axis, or in directions along a vertical axis when viewing **FIGS. 5-8**. In the illustrated embodiment, this certain distance is determined by adding the distance that the head **32** extends past the neck **34** in an occlusal direction to the distance that the head **32** extends past the neck **34** in a gingival direction. This certain distance decreases as the lingual side of the post **28** is approached and as a third section **46** of the clip **36** (as described below) is approached. This relationship is shown by the dashed lines in **FIG. 5** illustrating the occlusal and gingival sides of the neck **34**, in comparison to the full lines that depict the occlusal and gingival sides of the head **32**. Preferably, this certain distance is zero or approximately zero in regions adjacent the third section **46**.

[0041] In this embodiment, the archwire slot liner **24** has a rectangular mesial extension that extends over the buccolabial side of the post **28** and is connected to the same by the methods described in U.S. Pat. Nos. 5,358,402 and 5,380,196. However, other constructions are also possible. For example, the archwire slot liner **24** may have a mesial extension that is somewhat "T"-shaped, to match the generally "T"-shaped configuration presented by the neck **34** and the head **32** as depicted in **FIG. 3**. As yet another option, the mesial extension of the archwire slot liner **24** may be omitted such that the mesial end of the archwire slot liner **28** is flush with the mesial side of the mesial body portion **16**.

[0042] The appliance **10** also includes a latch for releasably retaining an archwire in the archwire slot **26**. In the illustrated embodiment, the latch includes a mesial clip **36** that is connected to the mesial post **28**, and a distal clip **38** that is connected to the distal post **30**. The mesial clip **36** is omitted from **FIGS. 3, 4** and **6** for purposes of illustration.

[0043] The mesial clip **36**, the neck **34** and an exemplary archwire **40** are shown alone in **FIGS. 7** and **8**. The mesial clip **36** includes an elongated occlusal or first section **42**, an elongated second or gingival section **44** and an elongated lingual or third section **46**. The first and second sections **42, 44** extend in generally parallel directions that lie along a generally buccolabial-lingual reference axis when the clip **36** is relaxed, and the third section **46** extends in a generally occlusal-lingual direction perpendicular to the direction of extension of the sections **42, 44**.

[0044] The third section **46** also integrally connects the first and second sections **42, 44**. Additionally, outer ends of the sections **42, 44** are integrally connected to arm portions **48, 50** respectively. A buccolabial edge of each arm portion **42, 44** is smoothly curved in an arc about a mesial-distal reference axis.

[0045] The sections **42, 44, 46** extend along the occlusal, gingival and lingual sides of the neck **34** respectively. In addition, each of the sections **42, 44** includes a somewhat triangular-shaped protrusion that extends along a portion of the buccolabial side of the neck **34**. A rear (lingual) portion of the first and second sections **42, 44**, along with the third section **46** and the protrusions **52** together at least partially define a recess **54** (see **FIGS. 2** and **8**) for receiving the neck **34** of the post **28**.

[0046] A front (buccolabial) portion of the first and second sections **42, 44**, along with the arm portions **48, 50** and a portion of the buccolabial side of the neck **34**, together at least partially define a region **56** for receiving the archwire **40**. As shown for example in **FIG. 5**, the region **56** is aligned with the archwire slot **26**. Overall, the clip **36** presents a generally "C"-shaped configuration when looking in a mesial or distal direction.

[0047] The clip **36** is shown in its normal, relaxed orientation in **FIGS. 1, 2, 5** and **7**. However, the arm portions **48, 50** are movable away from each other in order to admit the archwire **40** into the archwire-receiving region **56** when desired. To this end, the first and second sections **42, 44** deflect outwardly when the clip **36** is opened and bend in respective arcs away from each other in order to enable the arm portions **48, 50** to move apart from each other.

[0048] The smooth, outer edge of the arm portions **48, 50** enables the clip **36** to open and admit the archwire **40** into the region **56** by pressing the archwire **40** against the outer curved edges of the arm portions **48, 50**. As pressure is exerted by the archwire **40** on the curved edges, the first and second sections **42, 44** deflect away from each other in order to admit the archwire **40** into the region **56**. **FIG. 8** is an exemplary illustration showing the clip **36** opened, wherein the arm portions **48, 50** have been moved apart from each other a sufficient distance to permit passage of the archwire **40** into the region **56**.

[0049] As the clip **36** is opened, the protrusions **52** slide across the buccolabial side of the neck **34**. However, the protrusions **52** extend inwardly and toward each other a distance sufficient to remain in contact with the buccolabial side of the neck **34** as the clip **36** is opened. As such, the clip **36** remains coupled to the post **28** during such opening movements.

[0050] Once the archwire **40** is received in the region **56**, the inherent resiliency of the clip **36**, and particularly the

resiliency of the first and second sections **42, 44**, enables the arm portions **48, 50** to spring back toward each other and toward their normal, relaxed configuration as shown in **FIGS. 1, 2, 5** and **7** in order to retain the archwire **40** in the archwire slot **26**. Preferably, but not necessarily, the region **56** is somewhat larger than the cross-section of the archwire **40** in directions along both an occlusal-lingual reference axis as well as along a buccolabial-lingual reference axis, in order to avoid firm contact between the clip **36** and the archwire **40**. The spaces between the clip **36** and the archwire **40** provide what is often referred to as "passive" ligation.

**[0051]** The clip **36** (including the first and second sections **42, 44**) is sufficiently stiff to retain the archwire **40** in the archwire slot **26** during the course of treatment so long as the forces exerted by the archwire **40** on the appliance **10** are below a certain minimum value in a generally buccolabial direction (more particularly, in a direction opposite to the direction of insertion of the archwire **40** into the archwire slot **26**). However, whenever the forces exerted by the archwire **40** on the appliance **10** in the same direction are greater than the minimum value, as might occur when unexpectedly high forces are encountered, the first and second sections **42, 44** deflect outwardly and the arm portions **48, 50** move apart from each other to open the clip **36** and release the archwire **40** from the archwire slot **26**. Further details regarding such forces are described in the aforementioned U.S. Pat. Nos. 6,302,688 and 6,582,226.

**[0052]** Preferably, the clip **36** is substantially identical to the clip **38** and the post **28** is substantially identical in mirror image to the post **30**. The latch, comprising the clips **36, 38**, preferably releases the archwire **40** from the archwire slot **26** in a generally buccolabial direction whenever the archwire **40** exerts a force in the same direction on the appliance **10** that is in the range of about 0.2 lb (0.1 kg) to about 11 lb (5 kg), more preferably in the range of about 0.4 lb (0.2 kg) to about 5.5 lb (2.5 kg), and most preferably in the range of about 0.75 lb (0.34 kg) to about 3.0 lb (1.4 kg). Preferably, the minimum value is sufficiently high to prevent the archwire from unintentionally releasing from the archwire slot **26** during the normal course of orthodontic treatment. As such, the archwire **40** can exert forces on the appliance **10** sufficient to carry out the treatment program and move the associated teeth as desired.

**[0053]** Preferably, the minimum value for self-release (i.e., self-opening) of the latch is substantially less than the force required in the same direction to debond the appliance **10** from the associated tooth. The minimum value for self-release of the latch is preferably less than about one-half of the force required in the same direction to debond the appliance **10** from the associated tooth. For example, if the expected bond strength of the adhesive bond between the appliance **10** and the associated tooth is 16 lbs (7.2 kg) in a buccolabial direction, the latch is constructed to self-release the archwire **40** whenever the archwire **40** exerts a force in the same buccolabial direction on the appliance **10** that is somewhat greater than about 8 lbs (3.6 kg).

**[0054]** To determine the force to release the latch, a section of archwire is selected having an area in longitudinally transverse sections that is complementary to (i.e., substantially fills) the cross-sectional area of the archwire slot **32**. Next, a sling is constructed and is connected to the

archwire section at locations closely adjacent, but not in contact with the heads of the posts **28, 30** including the head **32**. Optionally, the sling is welded or brazed to the archwire section. Next, the sling is pulled away from the appliance **10** while the appliance **10** is held in a stationary position, taking care to ensure that the longitudinal axis of the archwire section does not tip relative to the longitudinal axis of the archwire slot **26**. The force to release the latch may be determined by use of an Instron testing apparatus connected to the sling, using a crosshead speed of 0.5 in/min (1.3 cm/min). Alternatively, a shaker apparatus (such as Model 300 from APS Dynamics of Carlsbad, Calif.) may be used along with a force transducer (such as model 208C01 from PCB of Buffalo, N.Y.) to measure the force.

**[0055]** Preferably, the distance between the opposed ends of the arm portions **48, 50** is less than the overall occlusal-lingual dimension of the smallest archwire **40** expected to be used during the course of treatment. The archwire **40** need not fill the archwire slot **26** and flatly engage the wall portions defining the archwire slot **26** in all instances. For example, a somewhat smaller wire, and perhaps an archwire **40** having a circular cross-sectional shape, may be used during a portion of the treatment program. The distance between the opposed ends of the arm portions **48, 50** is preferably selected so that a variety of archwires of different cross-sectional configurations may be used in connection with the appliance **10**.

**[0056]** Preferably, and as mentioned above, the distal clip **38** is substantially identical to the mesial clip **36**. Optionally, however, it is possible to construct the clips **36, 38** somewhat differently to address certain circumstances. For example, if a malpositioned tooth is initially oriented such that its mesial side is rotated in a lingual direction, it may be desirable to increase the stiffness of the mesial clip **36** so that a somewhat greater force is needed to release the archwire **40** from the archwire slot **26** in comparison to the force needed to release the archwire **40** from the distal clip **38**. Other options are also possible.

**[0057]** Optionally, the spring clips **36, 38** are cut from a flat section of metallic stock material. Suitable metallic materials include shape memory alloys such as alloys of nitinol and beta-titanium. The clips **36, 38** may be cut from the stock material using a stamping, die cutting, chemical etching, EDM (electrical discharge machining), laser cutting or water jet cutting process. As another option, the clips **36, 38** could be formed and then heat-treated to set their shapes.

**[0058]** As presently preferred, the clips **36, 38** are made from flat annealed superelastic material (such as nitinol) having a pickled surface. Preferred nitinol materials have a nickel content of 55.97% by weight and an  $A_f$  of  $10^\circ+5^\circ$  C. The nitinol is cold worked to 37.5% and has a thickness in the range of about 0.012 in. (0.3 mm) to about 0.016 in. (0.4 mm). The clips **36, 38** are first cut in a rough cutting EDM process, then cut along their edges for an additional one or more times using an EDM process in order to smooth the edges. Alternatively, a laser cutting process or chemical etching process could be used to make the clips **36, 38**. Preferably, the clips **36, 38** are constructed so that the longitudinal direction of the clip material, or the principal direction of grain flow of the clip material, is substantially parallel to the direction of extension of the first and second sections **42, 44** (i.e. a generally buccolabial direction in the illustrated embodiment).

[0059] Subsequent to the EDM, laser cutting or chemical etching process, the clips **36**, **38** are tumbled in order to further round their edges. An example of a suitable tumbling machine is model LC-600-2+2 from Richwood Industries. Using a small barrel, and a machine speed of 200 rpm, the clips are tumbled for about 2 hours in 500 cc of water and tumbling media. An example of suitable tumbling media is a mixture of 500 cc of ceramic media (shaped ACC, type M, size  $\frac{3}{16} \times \frac{3}{8}$  (4.7 mm $\times$ 9.5 mm)), 25 cc of white alumina powder no. 40, and 25 cc of soap powder compound no. 43, all from Richwood Industries. The tumbled clips are then polished for one-half hour in an ultrasonic screen barrel in a tank of solution. An example of a suitable solution is 3 liters of deionized water, 3 liters of pickling solution and 0.6 liter of hydrogen peroxide. A suitable pickling solution is No. T1121 Pickling Solution from Aya International of Los Angeles, Calif.

[0060] Other optional aspects of the clips **36**, **38** are described in applicant's published U.S. patent application entitled "ORTHODONTIC APPLIANCE WITH FATIGUE-RESISTANT ARCHWIRE RETAINING LATCH"; No. 2004/0086825, published May 18, 2004.

[0061] During manufacture of the appliance **10**, the archwire slot liner **24** is affixed to the body **14** and the clips **36**, **38** are then assembled to the posts **28**, **30** respectively. To connect the clip **36** to the post **28**, the clip **36** is opened by moving the sections **42**, **44** in directions away from each other a distance sufficient to clear the head **32** and enable the neck **34** to be received in the recess **54** by moving the clip **36** in a distal direction. Next, pressure on the sections **42**, **44** is relieved and the clip **36** springs back to its normal, relaxed configuration such as shown in FIGS. **1**, **2**, **5** and **7**, whereupon it is held in place by the head **32**.

[0062] The present invention provides a significant advantage, in that the protrusions **52** serve to hold the clip **36** in place on the post **28**. In particular, the protrusions **52** help prevent the clip **36** from moving in a lingual direction and disengaging the post **28** as might occur, for example, when the archwire **40** is pressed against the arm portions **48**, **50** for insertion into the archwire slot **26**. Such construction avoids the need for a base flange or other structure located on the lingual side of the third section **46**, which in turn enables the base or "footprint" of the appliance **10** to be somewhat smaller than might otherwise be expected.

[0063] Furthermore, the present invention surprisingly allows the archwire **40** to be inserted into the archwire slot **26** with less force than expected, while the force needed to self-release the latch remains approximately the same. In one experimental analysis done by computer, using software "ANSYS 8.0" from ANSYS, Inc. of Canonsburg, Pa., the force needed to ligate the archwire to the appliance and the force needed to release the archwire from the appliance were determined for an appliance having a clip constructed as shown in FIG. **8** and for a prior art appliance having a clip constructed as shown in FIG. **10**. A graph depicting the results determined for archwire ligation is set out in FIG. **11**, and a graph depicting the results determined for archwire release is set out in FIG. **12**.

[0064] The graph of FIG. **11** shows that a significantly higher force is needed for archwire ligation using the clip **36'** depicted in FIG. **10** in comparison to the force needed for archwire ligation using the clip **36** depicted in FIG. **8**. In

FIG. **1**, the maximum force needed to push the archwire **40** in a lingual direction to ligate the archwire to the appliance **10'** shown in FIG. **10** (i.e., the maximum force needed to push the archwire **40** in a lingual direction in order to spread apart arm portions **48'**, **50'** and move the archwire **40** into region **56'**) was 13.3 Newtons. By contrast, the maximum force needed to push the archwire **40** in a lingual direction to ligate the archwire **40** to the appliance **10** having the clip **36** was 8.3 Newtons.

[0065] The graph set out in FIG. **12** shows that the force needed to disengage or release the archwire from the archwire slot of both appliances is approximately the same. This is an advantage in that the likelihood of unintentional release of the archwire from both appliances during the course of treatment is also approximately the same. In FIG. **12**, a maximum force of 14.5 Newtons exerted on the archwire **40** in a buccolabial direction was needed to spread apart the arm portions **48'**, **50'** and move the archwire **40** out of the region **56'** in order to release the archwire **40** from the appliance. By contrast, the maximum force exerted on the archwire **40** in a buccolabial direction that was needed to release the archwire **40** from the appliance **10** was 13.8 Newtons.

[0066] In this experiment, both clips were made of the same material (super-elastic nitinol) and the thickness of the clips was 0.0128 inch (0.33 mm). In this experiment, the overall occlusal-gingival height and buccolabial-lingual width of the clip of the present invention were approximately 0.076 inch (1.88 mm) and 0.084 inch (2.13 mm) respectively. The occlusal-gingival height and buccolabial-lingual width for the clip **36'** shown in FIG. **10** were approximately 0.064 inch (1.62 mm) and 0.079 inch (2.00 mm) respectively.

[0067] As a result, the present invention facilitates insertion of the archwire **40** into the archwire slot **26** without adversely affecting the self-releasing aspects of the latch to any significant extent. This feature is a particular advantage in that the practitioner may ligate the archwire **40** to the appliance **10** with less force than might be otherwise possible. This feature is also beneficial to the patient, since less force is exerted on the patient's teeth during ligation and as a consequence any pain experienced by the patient is correspondingly reduced.

[0068] It was also found in the computer analysis described above that the strain exerted on the clip **36** during archwire ligation and release is reduced in comparison to the clip **36'** illustrated in FIG. **10**. The reduction is strain results in a higher fatigue life and reduces the possibility of fracture of the clip **36** during opening of the clip **36**.

[0069] A number of other constructions are also possible. For example, the body and/or base may be made of a metallic (such as stainless steel) or plastic material (such as fiber-reinforced polycarbonate) instead of the ceramic materials mentioned above. Furthermore, the archwire slot liner **24** is optional and may be omitted if desired.

[0070] All of the patents and patent applications mentioned above are hereby expressly incorporated by reference herein. The embodiments described in detail above and shown in the drawings are intended to exemplify the inven-

tion, and should not be deemed to limit the scope of the claims that follow.

- 1. An orthodontic appliance comprising:
  - a base;
  - a body extending outwardly from the base;
  - an archwire slot extending outwardly across the appliance in a generally mesial-distal direction;
  - a post extending outwardly from the body; and
  - a latch for releasably retaining an archwire in the archwire slot, wherein the latch comprises a clip with a region next to the archwire slot for receiving an archwire, wherein the clip also includes a recess that receives the post, wherein the recess is in communication with the archwire-receiving region, wherein the post includes a side that faces the region, and wherein the clip also includes at least one protrusion extending along the side of the post between the region and the recess.
- 2. An orthodontic appliance according to claim 1 wherein the protrusion is in contact with the post as an archwire is inserted into the archwire slot.
- 3. An orthodontic appliance according to claim 1 wherein the clip includes two protrusions that extended between the region and the recess, and wherein the protrusions extend inwardly in opposite directions toward each other.
- 4. An orthodontic appliance according to claim 1 wherein the clip includes a first section, a second section and a third section interconnecting the first section and the second section, and wherein the first section and the second section are movable away from each other to admit the post into the recess and are also movable away from each other to receive the archwire in the region.
- 5. An orthodontic appliance according to claim 4 wherein the protrusion is in contact with the post as an archwire is received in the region.
- 6. An orthodontic appliance according to claim 4 wherein the clip includes two protrusions that extend between the region and the recess, wherein the protrusions extend in opposite directions toward each other, wherein the side of the post has a certain size when considered in directions parallel to the directions of extension of the protrusions, and wherein the distance between the protrusions is smaller than the certain size.
- 7. An orthodontic appliance according to claim 6 wherein the certain size is determined in directions along an occlusal-gingival reference axis.
- 8. An orthodontic appliance according to claim 1 wherein the post includes a head and a neck interconnecting the head and the body, and wherein the side of the post is located on the neck.
- 9. An orthodontic appliance according to claim 8 wherein the side of the post faces a buccolabial direction.

- 10. An orthodontic appliance according to claim 1 wherein the latch comprises two clips.
- 11. An orthodontic appliance according to claim 1 wherein the clip has an overall, generally "C"-shaped configuration.
- 12. An orthodontic appliance comprising:
  - a base;
  - a body extending outwardly from the base;
  - an archwire slot extending across the appliance in a generally mesial-distal direction;
  - a post extending outwardly from the body; and
  - a latch for releasably retaining an archwire in the archwire slot, wherein the latch comprises a clip with a region next to the archwire slot for receiving an archwire, wherein the clip also includes a recess that receives the post, wherein the recess is in communication with the archwire-receiving region, wherein the post includes a side that faces the region, and wherein the clip also includes two protrusions that extend in opposite directions toward each other along the side of the post.
- 13. An orthodontic appliance according to claim 12 wherein the side of the post is a buccolabial side.
- 14. An orthodontic appliance according to claim 12 wherein the protrusions are in contact with the post as an archwire is inserted into the archwire slot.
- 15. An orthodontic appliance according to claim 12 wherein the clip includes a first section, a second section and a third section interconnecting the first section and the second section, and wherein the first section and the second section are movable away from each other to admit the post into the recess and are also movable away from each other to receive the archwire in the region.
- 16. An orthodontic appliance according to claim 15 wherein the protrusions are in contact with the post as an archwire is received in the region.
- 17. An orthodontic appliance according to claim 15 wherein one of the protrusions is part of the first section and wherein the other of the protrusions is part of the second section.
- 18. An orthodontic appliance according to claim 12 wherein the post includes a head and a neck interconnecting the head and the body, and wherein the side of the post is located on the neck.
- 19. An orthodontic appliance according to claim 18 wherein the side of the post faces a buccolabial direction.
- 20. An orthodontic appliance according to claim 12 wherein the latch comprises two clips.
- 21. An orthodontic appliance according to claim 12 wherein the clip has an overall, generally "C"-shaped configuration.

\* \* \* \* \*