



(51) International Patent Classification:

A61M 5/20 (2006.01) A61M 5/00 (2006.01)
A61M 5/32 (2006.01)

(21) International Application Number:

PCT/EP2011/073502

(22) International Filing Date:

21 December 2011 (21.12.2011)

(25) Filing Language:

English

(26) Publication Language:

English

(30) Priority Data:

10196067.2 21 December 2010 (21.12.2010) EP
61/432,255 13 January 2011 (13.01.2011) US

(71) Applicant (for all designated States except US): **SANOFI-AVENTIS DEUTSCHLAND GMBH** [DE/DE]; Brüningstraße 50, 65929 Frankfurt (DE).

(72) Inventors; and

(75) Inventors/Applicants (for US only): **HOORMAND, Yannick** [FR/GB]; 14 The Elms, Haslingfield, CB23 1ND (GB). **BARROW-WILLIAMS, Timothy Donald** [GB/GB]; 93 Castle Road, St. Albans, Herts AL1 5DQ (GB). **EKMAN, Matthew** [GB/GB]; 59 Ecton Avenue, Cheshire, Macclesfield Cheshire SK10 1RD (GB).

(81) Designated States (unless otherwise indicated, for every kind of national protection available):

AE, AG, AL, AM, AO, AT, AU, AZ, BA, BB, BG, BH, BR, BW, BY, BZ, CA, CH, CL, CN, CO, CR, CU, CZ, DE, DK, DM, DO, DZ, EC, EE, EG, ES, FI, GB, GD, GE, GH, GM, GT, HN, HR, HU, ID, IL, IN, IS, JP, KE, KG, KM, KN, KP, KR, KZ, LA, LC, LK, LR, LS, LT, LU, LY, MA, MD, ME, MG, MK, MN, MW, MX, MY, MZ, NA, NG, NI, NO, NZ, OM, PE, PG, PH, PL, PT, QA, RO, RS, RU, RW, SC, SD, SE, SG, SK, SL, SM, ST, SV, SY, TH, TJ, TM, TN, TR, TT, TZ, UA, UG, US, UZ, VC, VN, ZA, ZM, ZW.

(84) Designated States (unless otherwise indicated, for every kind of regional protection available):

ARIPO (BW, GH, GM, KE, LR, LS, MW, MZ, NA, RW, SD, SL, SZ, TZ, UG, ZM, ZW), Eurasian (AM, AZ, BY, KG, KZ, MD, RU, TJ, TM), European (AL, AT, BE, BG, CH, CY, CZ, DE, DK, EE, ES, FI, FR, GB, GR, HR, HU, IE, IS, IT, LT, LU, LV, MC, MK, MT, NL, NO, PL, PT, RO, RS, SE, SI, SK, SM, TR), OAPI (BF, BJ, CF, CG, CI, CM, GA, GN, GQ, GW, ML, MR, NE, SN, TD, TG).

Declarations under Rule 4.17:

— of inventorship (Rule 4.17(iv))

Published:

— with international search report (Art. 21(3))

(54) Title: AUTO-INJECTOR

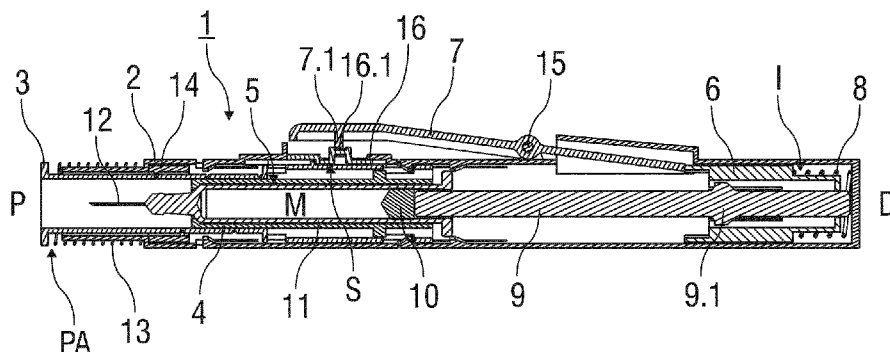

FIG 1A

(57) Abstract: According to the invention, an auto-injector (1) for administering a dose of a liquid medicament (M) comprises - a substantially cylindrical housing (2) arranged to contain a pre-filled syringe (5) filled with the medicament (M), - a needle shroud (3) slidably arranged with respect to the housing (2) and adapted to rest on the skin of a patient receiving an injection, - a releasable drive means (8) arranged within the housing (2) that is capable of, upon release, translating the needle shroud (3) in a proximal direction (P) towards a safe position (PS) and - a rotating collar (14) rotatably arranged within the housing (2). The needle shroud (3) in the safe position (PS) surrounds the injection needle (12) after the injection has been carried out. The rotating collar (14) engages the needle shroud (3) in a manner that forces the rotating collar (14) to rotate within the housing (2) when the needle shroud (3) is translated in the proximal direction (P).



Auto-injector

Technical Field

- 5 The invention relates to an auto-injector for administering a dose of a liquid medicament.

Background of the Invention

Administering an injection is a process which presents a number of risks and challenges
10 for users and healthcare professionals, both mental and physical.

Injection devices (i.e. devices capable of delivering medicaments from a medication container) typically fall into two categories – manual devices and auto-injectors.

15 In a manual device – the user must provide the mechanical energy to drive the fluid through the needle. This is typically done by some form of button / plunger that has to be continuously pressed by the user during the injection. There are numerous disadvantages to the user from this approach. If the user stops pressing the button / plunger then the injection will also stop. This means that the user can deliver an
20 underdose if the device is not used properly (i.e. the plunger is not fully pressed to its end position). Injection forces may be too high for the user, in particular if the patient is elderly or has dexterity problems.

The extension of the button/plunger may be too great. Thus it can be inconvenient for
25 the user to reach a fully extended button. The combination of injection force and button extension can cause trembling / shaking of the hand which in turn increases discomfort as the inserted needle moves.

Auto-injector devices aim to make self-administration of injected therapies easier for
30 patients. Current therapies delivered by means of self-administered injections include drugs for diabetes (both insulin and newer GLP-1 class drugs), migraine, hormone therapies, anticoagulants etc.

Auto-injectors are devices which completely or partially replace activities involved in parenteral drug delivery from standard syringes. These activities may include removal of a protective syringe cap, insertion of a needle into a patient's skin, injection of the medicament, removal of the needle, shielding of the needle and preventing reuse of the device. This overcomes many of the disadvantages of manual devices. Injection forces / button extension, hand-shaking and the likelihood of delivering an incomplete dose are reduced. Triggering may be performed by numerous means, for example a trigger button or the action of the needle reaching its injection depth. In some devices the energy to deliver the fluid is provided by a spring.

US 2002/0095120 A1 discloses an automatic injection device which automatically injects a pre-measured quantity of fluid medicine when a tension spring is released. The tension spring moves an ampoule and the injection needle from a storage position to a deployed position when it is released. The content of the ampoule is thereafter expelled by the tension spring forcing a piston forward inside the ampoule. After the fluid medicine has been injected, torsion stored in the tension spring is released and the injection needle is automatically retracted back to its original storage position.

20 Summary of the Invention

It is an object of the present invention to provide an improved auto-injector.

The object is achieved by an auto-injector according to claim 1.

25

Preferred embodiments of the invention are given in the dependent claims.

In the context of this specification, the terms distal and proximal are defined from the point of view of a person receiving an injection. Consequently, a proximal direction refers to a direction pointing towards the body of a patient receiving the injection and a proximal end defines an end of an element that is directed towards the body of the patient. Respectively, the distal end of an element or the distal direction is directed

30

away from the body of the patient receiving the injection and opposite to the proximal end or proximal direction.

According to the invention, an auto-injector for administering a dose of a liquid

5 medicament comprises

- a substantially cylindrical housing arranged to contain a pre-filled syringe filled with the medicament,

- a needle shroud slidably arranged with respect to the housing and adapted to rest on the skin of a patient receiving an injection,

10 - a releasable drive means arranged within the housing that is capable of, upon release, translating the needle shroud in a proximal direction towards a safe position and

- a rotating collar rotatably arranged within the housing. The needle shroud in the safe position surrounds the injection needle after the injection has been carried out. The

15 rotating collar engages the needle shroud in a manner that forces the rotating collar to rotate within the housing when the needle shroud is translated in the proximal direction.

A stopper may be arranged in the syringe barrel arranged to seal its distal end and to expel the dose of medicament. A coupling shroud may be slidably arranged within the housing and releasably coupled to a plunger that is connected to the stopper. The drive

20 means may be arranged between a distal end of the housing and the coupling shroud to bias the coupling shroud in a proximal direction towards the skin of a patient receiving an injection.

The rotating collar creates friction to slow down a proximal movement of the needle shroud that rests on the skin of the patient during the injection. The rotating collar acts

25 as a dampening element that alleviates the pressure exerted upon the skin of the patient by the needle shroud that is driven by the drive means. Thus, the risk of injuries is reduced and, in particular, bruises may be avoided. Furthermore, the modulus of resilience of the single drive means may be chosen to be sufficiently large without

30 having to worry about potential injury risks. Thus, the modulus of resilience of the drive means is adapted to reliably provide an energy supply for executing a plurality of actions comprising, among others, the advancing and releasing of the needle shroud,

the displacement of the stopper to expel the medicament and the decoupling of the plunger and the coupling shroud.

5 Preferably, the rotating collar comprises a pin that engages a helical recess formed into the needle shroud. The engagement of the helical recess and the pin forces the rotating collar to rotate around the needle shroud when the needle shroud is translated. This dampens the proximal movement of the needle shroud and thus reduces the pressure exerted upon the skin of the patient by generating friction.

10 According to a possible embodiment of the invention, the needle shroud is slidable in a distal direction from an advanced position to a retracted position. In particular, the needle shroud may be slid to the retracted position by placing the auto-injector onto the skin of the patient receiving the injection and pressing the needle shroud against the skin of the patient. The needle shroud in the retracted position indicates the correct
15 placement of the auto-injector. An activation of a mechanism of the auto-injector delivering the medicament to the patient requires the needle shroud to be positioned in the retracted position to ensure that the auto-injector is properly used. The needle shroud is slidable in the proximal direction from the retracted position to the safe position, wherein the needle shroud surrounds an injection needle of the pre-filled
20 syringe to prevent accidental needle stick injuries after the injection has been carried out.

According to another possible embodiment of the invention, the drive means is arranged to be released by manual actuation of a release element that is hinged to a lateral side
25 of the housing. Conventional auto-injectors are commonly activated by actuating a push button or the like arranged at a distal end of the auto-injector. An inexperienced user of such a conventional auto-injector may easily mistake the distal end for a proximal end of the auto-injector and thus may pierce his finger while trying to actuate the auto-injector. The lateral arrangement of the release element is a simple means to prevent such
30 accidental needle stick injuries resulting from a misuse of the auto-injector.

Alternatively, the release element is in slidable arrangement with the housing and may be translated with respect to the housing in the proximal direction to release the drive means. The auto-injector according to this embodiment of the invention is particularly intuitive to operate.

5

According to another possible embodiment of the invention, the auto-injector comprises safety means that cooperate with the needle shroud that is arranged to prevent a release of the drive means when the needle shroud is in the advanced position and hence is not pushed against the skin of the patient. This mechanism avoids an early

10

release of the drive means and thus a premature expelling of the medicament. Furthermore, injuries resulting from an activation of the drive means when the auto-injector is not placed, or not properly placed onto the skin of the patient are reduced.

15

The safety means may comprise a blocking element slidably arranged relative to the housing. The blocking element is arranged to limit a pivoting movement of the release element hinged to the lateral side of the housing when the needle shroud is in the advanced position. A release of the drive means is thus prevented. The release element is allowed to pivot about the hinge when the needle shroud is moved to the retracted position by pressing the needle shroud against the skin surface of the patient receiving

20

the injection. In one possible embodiment of the invention, the safety means comprises an elastic bushing that engages a plunger of the pre-filled syringe and/or a coupling shroud that is biased by the drive means and coupled to the plunger of the pre-filled syringe. The

25

elastic bushing is firmly attached to a proximal end of the housing and may engage the coupling shroud and/or the plunger to prevent an inadvertent release of the drive means.

30

In another preferred embodiment of the invention, the drive means is capable of, upon release, driving the coupling shroud releasably coupled to the plunger from a first position in the proximal direction. The coupling shroud is driven by the drive means to interact with different components of the auto-injector, so that the resilient force provided by the drive means may be used to power a variety of functions of the auto-

injector. The proximal translatory movement of the coupling shroud with respect to the housing

- translates a syringe retainer receiving the pre-filled syringe in the proximal direction to expose the injection needle of the pre-filled syringe,

5 - depresses the plunger connected to a stopper into the syringe barrel to expel the dose of medicament and

- translates the needle shroud in the proximal direction. The coupling shroud mediates the resilient force provided by the drive means to this variety of different components of the auto-injector and thus allows for a compact design of the auto-injector. In particular,

10 the auto-injector may be powered by just a single drive means to accomplish a plurality of tasks necessary for safely carrying out the injection.

According to yet another possible embodiment of the invention, the syringe retainer is releasably mounted to the housing. The needle shroud in the retracted position releases

15 the syringe retainer to allow for the proximal translation of the syringe retainer with respect to the housing. Thus, a proximal movement of the syringe retainer that in particular inserts the injection needle into the skin of the patient is prevented until the auto-injector is correctly placed upon the skin of the patient and the needle shroud is pushed against the skin surface towards the retracted position. This prevents an

20 inadvertent early release of the drive means.

The coupling shroud is initially in a first position, and coupled to the plunger to translate the syringe retainer proximally, whereby the injection needle is inserted into the skin of the patient, and to depress the stopper into the syringe barrel to expel the medicament.

25 The plunger and the coupling shroud are decoupled from each other at the proper pre-determined second position after the medicament has been completely or partially delivered. The pre-determined second position is defined by a longitudinal aperture in the housing.

30 According to another possible embodiment of the invention, a coupling catch is arranged to abut against a shoulder formed to the plunger as a particularly simple and reliable means to releasably couple the plunger to the coupling shroud. The coupling

shroud is moved by the action of the relaxing drive means in the proximal direction and is coupled to the plunger connected to the stopper to insert the injection needle before the injection and to expel the medication during the injection.

5 The aperture formed into the lateral side of the housing at the second position allows the coupling catch to deflect radially outwards at the second position, so that the coupling shroud is decoupled from the plunger after the medicament is partially or completely delivered.

10 Preferably, the drive means is arranged as a single compression spring. The mechanism of the auto-injector is arranged in a manner that a plurality of functions is executed by the single drive means. The injection needle is inserted into the skin of the patient, the plunger is translated to expel the medicament and the needle shroud is moved proximally to provide needle safety after the injection is completed by the action
15 of the spring means. Conventional auto-injectors usually comprise a plurality of spring means to accomplish these tasks. The auto-injector according to the invention comprises only few parts and is particularly inexpensive to mass-produce. Consequently, the auto-injector is particularly suited as a single-use device that may be disposed after an injection has been carried out.

20 The auto-injector may preferably be used for subcutaneous or intra-muscular injection, particularly for delivering one of an analgetic, an anticoagulant, insulin, an insulin derivate, heparin, Lovenox, a vaccine, a growth hormone, a peptide hormone, a proteine, antibodies and complex carbohydrates.

25 Further scope of applicability of the present invention will become apparent from the detailed description given hereinafter. However, it should be understood that the detailed description and specific examples, while indicating preferred embodiments of the invention, are given by way of illustration only, since various changes and
30 modifications within the spirit and scope of the invention will become apparent to those skilled in the art from this detailed description.

Brief Description of the Drawings

The present invention will become more fully understood from the detailed description given hereinbelow and the accompanying drawings which are given by way of illustration only, and thus, are not limitive of the present invention, and wherein:

- 5
- 10
- 15
- 20
- 25
- 30
- Figures 1A und 1B show two different sectional views of an auto-injector according to a first embodiment of the invention with a hinged release element before an injection,
- Figure 2 an expanded sectional view of the auto-injector according to the first embodiment, wherein the release element is blocked to prevent an inadvertent release of a drive means,
- Figure 3 an expanded sectional view of the hinged release element that is actuated to release the drive means,
- Figures 4A and 4B two different sectional views of the auto-injector according to the first embodiment after a drug has been delivered,
- Figure 5 an isometric view of a needle shroud,
- Figures 6A and 6B two different sectional views of the auto-injector according to the first embodiment after an injection has been performed,
- Figures 7A and 7B two different sectional views of an auto-injector according to a second embodiment of the invention,
- Figure 8 a sectional view of a distal end section of the auto-injector according to the second embodiment of the invention,

Figure 9A and 9B two different sectional views of an auto-injector according to a third embodiment of the invention,

5 Figure 10 a sectional view of a distal end section of the auto-injector according to the third embodiment of the invention.

Corresponding parts are marked with the same reference symbols in all figures.

Detailed Description of Preferred Embodiments

10

Figures 1A and 1B show two sectional views of an essentially cylindrical auto-injector 1 according to a first embodiment of the invention, wherein the sectional plane shown in figure 1A is oriented perpendicularly to the one shown in figure 1B. The auto-injector 1 comprises a housing 2, a proximal needle shroud 3, a syringe retainer 4 adapted to
15 mount and move translatably with a pre-filled syringe 5 within the housing 2, a coupling shroud 6 slidably arranged within the housing 2 and a release element 7 hinged to a lateral side of the substantially cylindrical housing 2 of the auto-injector 1.

A single drive means 8 is arranged between the distal end of the housing 2 and the
20 coupling shroud 6 to bias the coupling shroud 6 in a proximal direction P towards the skin of a patient receiving an injection.

According to one possible embodiment of the invention, the drive means 8 is arranged
25 as a single, conventional compression spring.

25

The coupling shroud 6 is releasably coupled to a plunger 9 that is connected to a stopper 10 fluid-tightly sealing a distal end of a syringe barrel 11 containing a dose of a medicament M. An inner cavity of the syringe barrel 11 is in fluid communication with an injection needle 12, so that the dose of the medicament M may be expelled through the
30 injection needle 12 by displacing the stopper 10 in the proximal direction P.

Before the injection, the coupling shroud 6 abuts against a distal end of the release element 7 to releasably retain the coupling shroud 6 in a first position I, wherein the coupling shroud 7 is located at a distal end of the housing 2. The drive means 8 is compressed, so that the coupling shroud 6 is strongly biased in the proximal direction P.

5

The plunger 9 extends from the syringe barrel 11 in a distal direction D and comprises a shoulder 9.1 of increased diameter. The coupling shroud 6 comprises an inwardly protruding coupling catch 6.1 that bears against the shoulder 9.1 so that the plunger 9 and the coupling shroud 6 may be jointly moved in the proximal direction P by the action of the relaxing drive means 8.

10

The proximal end of the needle shroud 3 is designed to be pushed against the skin surface of the patient during the injection. Edges of the needle shroud 3 may thus be smoothed to avoid injuries. The needle shroud 3 is slidably arranged within the housing 2 of the auto-injector 1, so that the needle shroud 3 may be pushed from an advanced position PA shown in figures 1A and 1B in the distal direction D. A biasing means 13 bears against the needle shroud 3 and the housing 2 to bias the needle shroud 3 towards the advanced position PA.

15

An annular rotating collar 14 engages an outer surface of the needle shroud 3. The rotating collar 14 rotates around an axis of the substantially cylindrical auto-injector 1 when the needle shroud 3 is longitudinally displaced in the proximal and/or the distal direction P, D. The rotating collar 14 acts as a damping means that creates friction to slow down the movement of the needle shroud 3 and to reduce the pressure exerted onto the skin of the patient receiving the injection.

25

The release element 7 hinged to the housing 2 works like a see-saw: a proximal section may be pushed radially inwards, whereby the release element 7 pivots about a hinge 15, so that the distal section of the release element 7 moves radially outwards and the coupling shroud 6 is disengaged to release the drive means 8.

30

The auto-injector 1 comprises safety means S that prevent an early release of the drive means 8. The safety means S ensure that the needle shroud 3 is pushed against the skin of the person receiving the injection before the drive means 8 may be released.

5 According to the first embodiment of the invention, the safety means S comprise a blocking element 16 slidably arranged with the housing 2. When the needle shroud 3 is positioned in the advanced position PA, the blocking element 16 is positioned to prevent a pivoting movement of the release element 7 and thus a release of the coupling shroud 6. A radially outwards protruding blocking projection 16.1 of the blocking
10 element 16 is located opposite to an inward protrusion 7.1 formed to the release element 7. If the proximal section of the release element 7 is pushed inwards, the inward protrusion 7.1 abuts against the blocking projection 16.1 to limit the pivoting movement of the release element 7, so that a release of the coupling shroud 6 and the drive means 8 is prevented.

15

Figure 2 shows a proximal section of the auto-injector 1 in a sectional view with the blocking element 16 positioned to prevent an inadvertent actuation of the hinged release element 7 to release the drive means 8.

20 A distal end of the needle shroud 3 is clipped to the housing 2 and retained between two inwardly protruding retaining protrusions 2.1 formed into an inner surface of the housing 2. The two retaining protrusions 2.1 are longitudinally displaced from each other to limit the range of axial displacement of the needle shroud 3 with respect to the housing 2. A boss 3.1 formed into an outer surface of the needle shroud 3 bears against
25 an inner surface of the blocking element 16, so that the blocking element 16 may move with the needle shroud 3 in the proximal direction P to deblock the release element 7.

The blocking projection 16.1 comprises a central indentation that forces a user of the auto-injector 1 to perform a sequence of actions necessary to inject the dose of the
30 medicament M in the proper order. If the release element 7 is pushed inwards before the needle shroud 3 is moved proximally from the advanced position PA towards a retracted position PR (see Figure 3) by pushing the needle shroud 3 towards the skin of

the patient, the inward projection 7.1 is retained in the central indentation of the blocking projection 16.1, so that both the longitudinal displacement of the needle shroud 3 and the pivoting movement of the release element 7 is blocked.

5 A proper sequence of actions for injecting the dose of the medicament M is described in the following. First, the user pushes the needle shroud 3 against the skin to move the needle shroud 3 distally to the retracted position PR illustrated in figure 3. The blocking element 16 jointly moves with the needle shroud 3 in the distal direction D, so that the release element 7 may be manually actuated to pivot about the hinge 15, whereby the
10 drive means 8 are released.

Upon release of the drive means 8, the coupling shroud 6 is urged in the proximal direction P. The single and fully compressed drive means 8 drives the coupling shroud 6 and the plunger 9 coupled thereto in the proximal direction P. The coupling shroud 6
15 first pushes the syringe retainer 4 by means of plunger 9, stopper 10 and the friction between stopper 10 and syringe 11 proximally to insert the injection needle 12 into the skin of the patient and a first clip connection 2.2 formed into a lateral side of the housing 2 latches to an outward protrusion 4.1 of the syringe retainer 4, as illustrated in more detail in figure 4B.

20 The syringe retainer 4 and the pre-filled syringe 5 mounted thereto is now locked to the housing 2. The coupling shroud 6 is moved further in the proximal direction P by the action of the relaxing drive means 8, whereby the plunger 9 is depressed into the syringe barrel 11 to expel the dose of the medicament M contained therein through the
25 injection needle 12.

Figure 4A and 4B show two sectional views of the auto-injector 1 according to the first embodiment of the invention with the plunger 9 fully depressed within the syringe barrel 11. The dose of the medicament M has been delivered beneath the skin of the
30 patient. The coupling shroud 6 is located in an intermediate second position II. The drive means 8 is not yet completely discharged and biases the coupling shroud 6 in the proximal direction P. The shoulder 9.1 engages a ramp of the coupling catch 6.1 to

deflect the coupling catch 6.1 in a radial outward direction. An aperture 2.3 is formed into the housing 2 to allow for a radial outward deflection of the coupling catch 6.1, so that the coupling catch 6.1 overcomes the shoulder 9.1 decoupling the coupling shroud 6 from the plunger 9.

5

In a possible embodiment of the invention, the aperture 2.3 defining the second position II is located at a longitudinal position along the housing 2 that allows for a full depression of the plunger 9 completely emptying the syringe barrel 11 before the plunger 9 is decoupled from the coupling shroud 6.

10

Alternatively, the aperture 2.3 defining the second position II may be located at a longitudinal position along the housing 2 that allows for an adjustment space accounting for manufacturing tolerances. The adjustment space is dimensioned as to allow for a reliable decoupling of the plunger 9 from the coupling shroud 6 even if the parts constituting the auto-injector 1 comprise mismatch in mould or are slightly misaligned. In this alternative embodiment, the dose of the medicament M may or may not be completely expelled before the plunger 9 is decoupled from the coupling shroud 6.

15

The retaining protrusions 2.1 are elastically supported and may be deflected radially outwards to release the needle shroud 3. The coupling shroud 6 engages a ramp of the retaining protrusions 2.1 and splays the retaining protrusions 2.1 outwards, whereby the needle shroud 3 is released and allowed to move proximally from the retracted position PR towards an extended safe position PS.

20

25

The drive means 8 is still partially loaded when the coupling shroud 6 is located in the second position II. In a possible embodiment of the invention the biasing force of the drive means 8 exerted on the coupling shroud 6 in the second position II is about 10 N.

30

The coupling shroud 6 bears against a distal end of the needle shroud 3, so that the needle shroud 3 may be moved to the safe position PS by the action of the further relaxing drive means 8. As the biasing force exerted onto the needle shroud 3 by the drive means 8 may be relatively large and could even bruise the patient, the rotating

collar 14 is arranged within the housing 2 to partially absorb the excess energy of the drive means 8 and slow down the proximal movement of the needle shroud 3 by generating friction.

5 Figure 5 shows an isometric view of the needle shroud 3. A helical recess 3.2 is formed into a tubular proximal section 3.3 of the needle shroud 3. The proximal section 3.3 of the needle shroud 3 is inserted into the annular rotating collar 14, wherein a pin 14.1 formed to an inner surface of the rotating collar 14 protrudes into the helical recess 3.2 as shown in figure 6A. The linear translatory movement of needle shroud 3 towards the
10 safe position PS thus causes the rotating collar 14 to rotate within the housing 2 around the axis of the auto-injector 1.

Figures 6A and 6B show two different sectional views of the auto-injector 1 according to the first embodiment of the invention after the injection has been performed. The needle
15 shroud 3 is permanently locked to the safe position PS by a second clip connection 2.4 formed into the housing 2. The needle shroud 3 surrounds the injection needle 12 and extends a suitable distance proximally beyond the needle tip to avoid accidental needle stick injuries after the auto-injector 1 has been used.

20 Figures 7A and 7B show two different sectional views of an auto-injector 1 according to a second embodiment of the invention before the injection. The sectional plane shown in figure 7A is oriented perpendicularly to the sectional plane shown in figure 7B.

The needle shroud 3 of the auto-injector 1 according to the second embodiment
25 substantially extends over the axial length of the housing 2. Before the injection, the needle shroud 3 is mounted to the housing 2 by the retaining protrusions 2.1 that protrude into orifices formed into a lateral side of the needle shroud 3. The orifices comprise a longitudinal length that allows the needle shroud 3 to be slid from the advanced position PA to the retracted position PR.

30

A retaining catch 2.5 is formed to an inner surface of the housing 2 and protrudes through an opening formed into the needle shroud 3 to releasably mount the syringe

retainer 4 retaining the pre-filled syringe 5. The retaining catch 2.5 comprises a bevelled ramp and is deflectable in a radial outward direction. The retaining catch 2.5 latches to the outward protrusion 4.1 formed to the outer surface of the syringe retainer 4 when the needle shroud 3 is in the advanced position PA

5 The needle shroud 3 abuts against the bevelled ramp of the retaining catch 2.5 when the needle shroud 3 is moved from the advanced position PA in the distal direction D, whereby the retaining catch 2.5 is deflected in a radial outward direction and disengages the outward protrusion 4.1, so that the syringe retainer 4 may be moved in the proximal direction P.

10

The release element 7, shown in more detail in figure 8, is arranged as a push button and mounted to a distal end of the housing 2. The release element 7 may be pushed in the proximal direction P to release the drive means 8 when the needle shroud 3 is in the retracted position PR, whereas the release element 7 and thus the release of the drive

15

means 8 is blocked when the needle shroud 7 is in the advanced position PA.

According to the second embodiment of the invention, the safety means S that prevent the early release of the drive means 8 comprises clips 2.6 that may deflect in a radial outward direction and a bushing 17 locking the plunger 9 before use of the auto-

20

injector 1.

Before the auto-injector 1 is used, the clips 2.6 formed to the housing 8 latch to the release element 7. (See Figure 7B) The clips 2.6 block the movement of the release element 7 in the proximal direction P, so that a manual actuation of the release

25

element 7 is prevented as long as the needle shroud 3 is in the advanced position PA. A distal movement of the release element 7 is blocked by a first detent 2.7 engaging an inner surface of the release element 7.

The clip 2.6 comprises a ramp that the needle shroud 3 engages when pushed distally

30

from the advanced position PA to the retracted position PR, whereby the clip 2.6 is deflected radially outwards to disengage the needle shroud 3. The release element 7

may be pushed in the proximal direction P when the needle shroud 3 is in the retracted position PR.

5 The plunger 9 comprises a distal end 9.2 of increased diameter that is retained in the bushing 17 firmly attached to a distal end of the housing 2. The bushing 17 comprises an inner surface corresponding to the distal end 9.2 of the plunger 9 that engages the distal end 9.2 in a locked position L to lock the plunger 9 and the coupling shroud 6 coupled thereto to the housing 2 before use of the auto-injector 1. The bushing 17 abuts radially against an annular inner collar 7.2 of the release element 7 in the locked
10 position L shown in figures 7A and 7B. A radial outward deflection of the bushing 17 releasing the plunger 9 is thus prevented.

Figure 8 shows a sectional view of a distal end section of the auto-injector 1 according to the second embodiment of the invention. The needle shroud 3 is located in the retracted position PR and the release element 7 is pushed in the proximal direction P,
15 so that the bushing 17 disengages the annular inner collar 7.2 of the release element 7. The bushing 17 is positioned in an unlocked position U and may deflect outwardly to release the plunger 9.

20 Furthermore, the bushing 17 acts as a counter bearing for the drive means 8 bearing against the bushing 17 in the distal direction D.

Figure 9A and 9B show two different sectional views of an auto-injector 1 according to a third embodiment of the invention, wherein the release element 7 is arranged as an
25 outer sleeve extending over a substantial length of the auto-injector 1.

According to the third embodiment of the invention, the safety means S that prevent the early release of the drive means 8 comprise clips 2.6, second and third detents 2.8, 7.3, a locking catch 6.2 formed to the coupling shroud 6 and the bushing 17 that comprises
30 an inner sleeve 17.1 receiving a lug 7.4, wherein the locking catch 6.2 latches to a collar 17.2 of the inner sleeve 17.1.

The release element 7 of the third embodiment is gripped by a user to perform the injection. When the needle shroud 3 is in the advanced position PA, the proximal displacement of the release element 7 is blocked by the clips 2.6 in a similar manner as in the second embodiment described herein above.

5

Additionally, the release element is releasably retained in position before the injection by the second and the third detents 2.8, 7.3 respectively formed to an outer surface of the housing 2 and to an inner surface of the release element 7, wherein the second and third detents 2.8, 7.3 comprise correspondingly shaped ramps facing each other.

10

The bushing 17 of the third embodiment comprises the inner sleeve 17.1 that receives the lug 7.4 formed to an inner surface of the release element 7. A proximal end of the lug 7.4 snugly fits in the central aperture of the inner sleeve 17.1, so that an inward deflection of the inner sleeve 17.1 is prevented.

15

The inner sleeve 17.1 comprises a collar 17.2. An inwardly protruding locking catch 6.2 of the coupling shroud 6 latches to the collar 17.2 before use of the auto-injector 1 to releasably retain the coupling shroud 6 in the first position I.

20 Figure 10 shows a sectional view of a distal end section of the auto-injector 1 according to the third embodiment of the invention. The release element 7 is actuated and moved in the proximal direction P. The proximal end of the lug 7.4 disengages the inner sleeve 17.1 of the bushing 17, so that the inner sleeve 17.1 may bend radially inwards, whereby the locking catch 6.2 disengages the collar 17.2 and releases the coupling
25 shroud 8 and the drive means 8.

List of References

	1	auto-injector
	2	housing
5	2.1	retaining protrusion
	2.2	first clip connection
	2.3	aperture
	2.4	second clip connection
	2.5	retaining catch
10	2.6	clip
	2.7	first detent
	2.8	second detent
	3	needle shroud
	3.1	boss
15	3.2	helical recess
	3.3	proximal section
	4	syringe retainer
	4.1	outward protrusion
	5	pre-filled syringe
20	6	coupling shroud
	6.1	coupling catch
	6.2	locking catch
	7	release element
	7.1	inward protrusion
25	7.2	inner collar
	7.3	second detent
	7.4	lug
	8	drive means
	9	plunger
30	9.1	shoulder
	9.2	distal end
	10	stopper

	11	syringe barrel
	12	injection needle
	13	biasing means
	14	rotating collar
5	14.1	pin
	15	hinge
	16	blocking element
	16.1	blocking projection
	17	bushing
10	17.1	inner sleeve
	17.2	collar
	M	medicament
	S	safety means
	I	first position
15	II	second position
	PA	advanced position
	PR	retracted Position
	PS	safe position
	L	locked position
20	U	unlocked position
	P	proximal direction
	D	distal direction

Claims

1. Auto-injector (1) for administering a dose of a liquid medicament (M),
comprising
5 - a substantially cylindrical housing (2) arranged to contain a pre-filled
syringe (5) filled with the medicament (M),
- a needle shroud (3) slidably arranged with respect to the housing (2) and
adapted to rest on the skin of a patient receiving an injection,
- a releasable drive means (8) arranged within the housing (2) that is capable of,
10 upon release, translating the needle shroud (3) in a proximal direction (P)
towards a safe position (PS),
- a rotating collar (14) rotatably arranged within the housing (2),
wherein the needle shroud (3) in the safe position (PS) surrounds the injection
needle (12) and wherein the rotating collar (14) engages the needle shroud (3)
15 in a manner that forces the rotating collar (14) to rotate within the housing (2)
when the needle shroud (3) is translated in the proximal direction (P) towards
the safe position (PS).
2. Auto-injector (1) according to claim 1,
20 characterized in that the rotating collar (14) comprises a pin (14.1) that
engages a helical recess (3.2) formed into the needle shroud (3).
3. Auto-injector (1) according to claim 1 or 2,
characterized in that the needle shroud (3) is slidable from an advanced
25 position (PA) in a distal direction (D) to a retracted position (PR) and from the
retracted position (PR) in the proximal direction (P) to the safe position (PS).
4. Auto-injector (1) according to one of the previous claims,
characterized in that the drive means (8) arranged to be released by manual
30 actuation of a release element (7) that is hinged to the housing (2) or slidably
arranged with respect to the housing (2).

5. Auto-injector (1) according to claim 3 or 4,
characterized in that safety means (S) are arranged to cooperate with the
needle shroud (3) to prevent a release of the drive means (8) when the needle
shroud (3) is in the advanced position (PA).
- 5
6. Auto-injector (1) according to claim 5,
characterized in that the safety means (S) comprise a blocking element (16)
that is slidably arranged relative to the housing (2), wherein the blocking
element (16) is arranged to limit a pivoting movement of the release
element (7) hinged to a lateral side of the housing (2) when the needle
shroud (3) is in the advanced position (PA) and wherein the blocking
element (16) is arranged to allow the release element (7) to pivot about a
hinge (15) when the needle shroud (3) is in the retracted position (PR).
- 10
7. Auto-injector (1) according to claim 5,
characterized in that the safety means (S) comprise a bushing (17) that
engages a plunger (9) of the pre-filled syringe (5) and/or a coupling shroud (6)
slidably arranged within the housing (2) to prevent the release of the drive
means (8).
- 15
8. Auto-injector (1) according to claim 7,
characterized in that the drive means (8) is capable of, upon release, driving
the coupling shroud (6) releasably coupled to the plunger (9) from a first
position (I) in the proximal direction (P), wherein the proximal translatory
movement of the coupling shroud (6) with respect to the housing (2)
- translates a syringe retainer (4) receiving the pre-filled syringe (5) in the
proximal direction (P) to expose the injection needle (12) of the pre-filled
syringe (5),
- depresses the plunger (9) connected to a stopper (10) into the syringe
barrel (11) to expel the dose of medicament (M) and
- translates the needle shroud (3) in the proximal direction (P).
- 20
- 25
- 30

- 5 9. Auto-injector (1) according to claim 8,
characterized in that the syringe retainer (4) is releasably mounted to the
housing (2), wherein the needle shroud (3) in the retracted position (PR) is
arranged to release the syringe retainer (4) to allow for the proximal translation
of the syringe retainer (4) with respect to the housing (2).
- 10 10. Auto-injector (1) according to one of the claims 7 to 9,
characterized in that the coupling shroud (6) is arranged to be decoupled from
the plunger (9) at a pre-determined second position (II) defined by an
aperture (2.3) formed into the housing (2).
- 15 11. Auto-injector (1) according to one of the claims 7 to 10,
characterized in that a coupling catch (6.1) is arranged to abut against a
shoulder (9.1) formed to the plunger (9) to releasably couple the plunger (9) to
the coupling shroud (6).
- 20 12. Auto-injector (1) according to claim 11,
characterized in that the aperture (2.3) allows the coupling catch (6.1) to deflect
radially outwards to decouple the coupling shroud (6) from the plunger (9) at
the second position (II).
- 25 13. Auto injector (1) according to one of the previous claims,
characterized in that the drive means (8) is arranged as a single compression
spring.

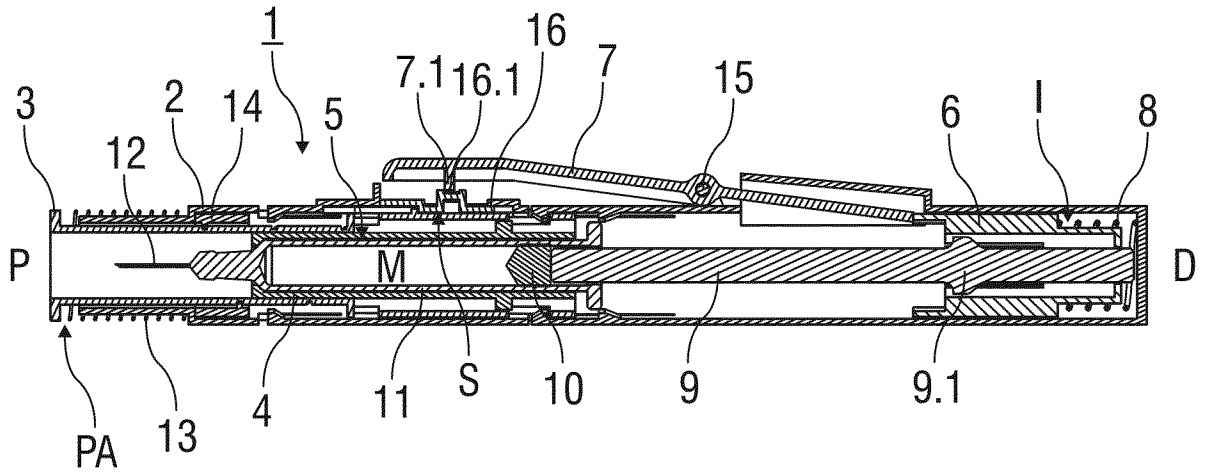

FIG 1A

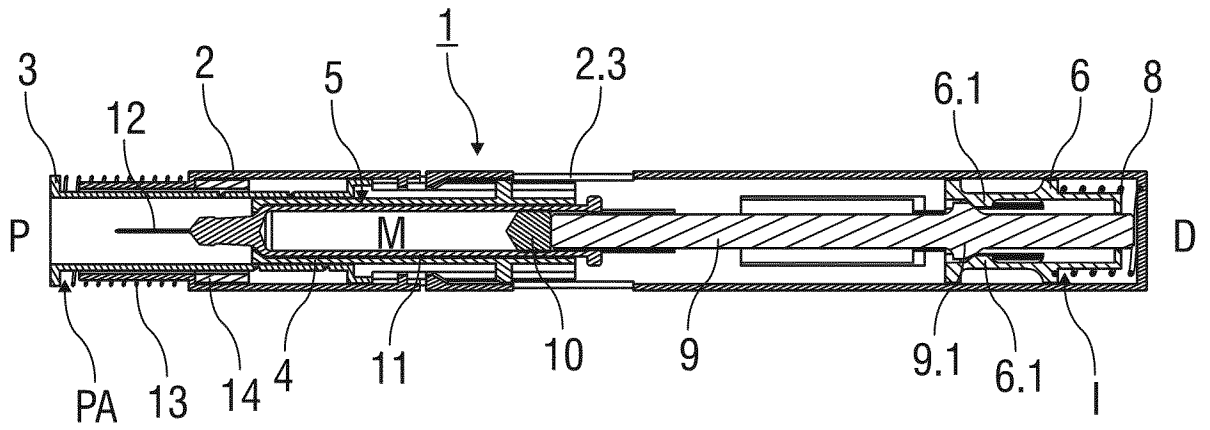

FIG 1B

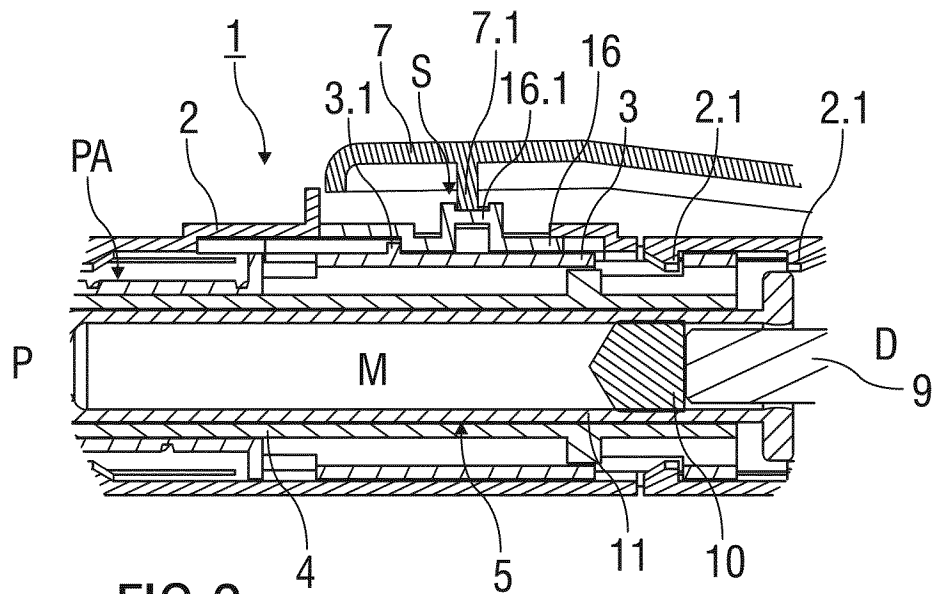

FIG 2

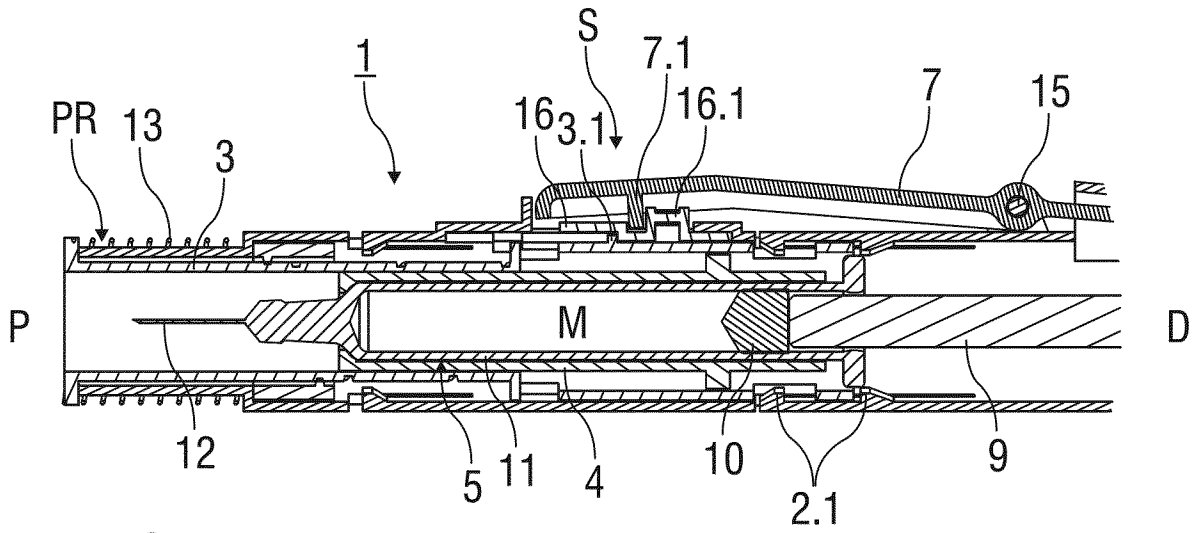

FIG 3

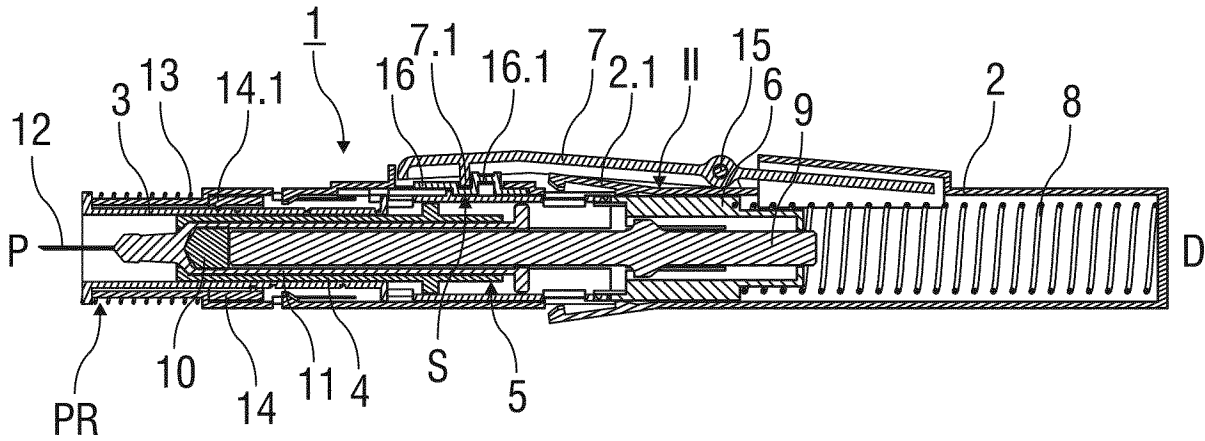

FIG 4A

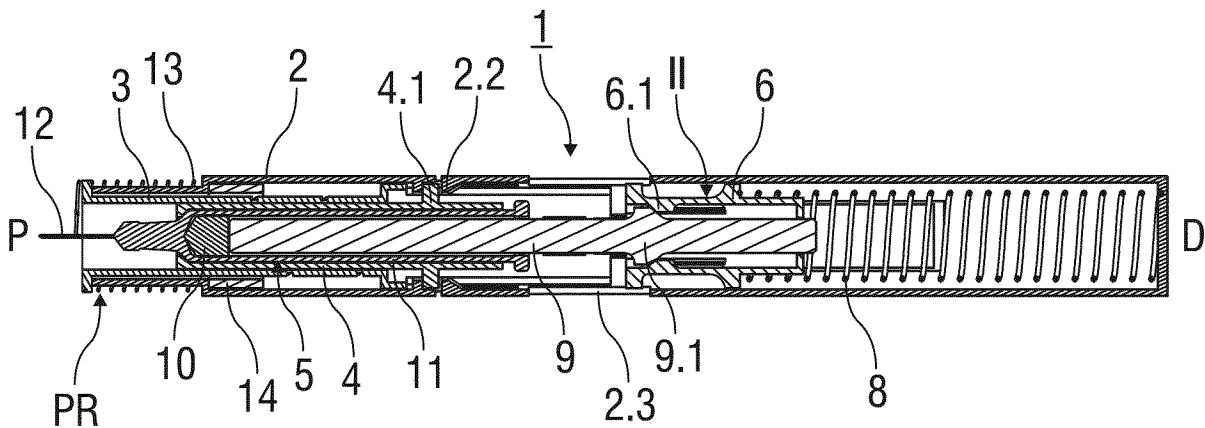

FIG 4B

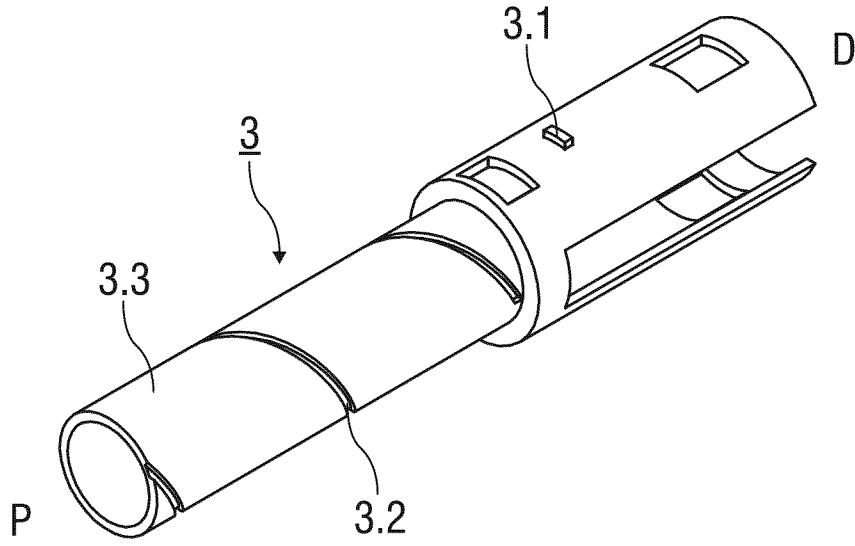

FIG 5

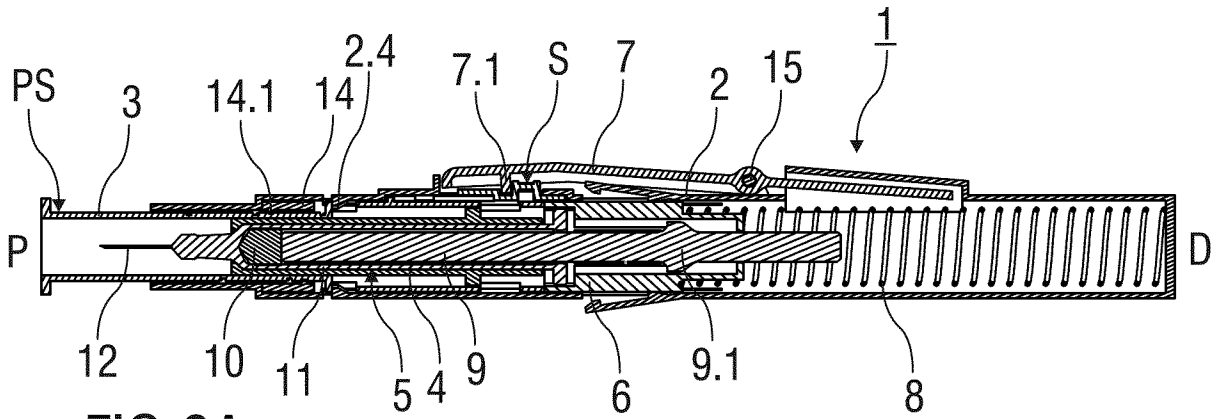

FIG 6A

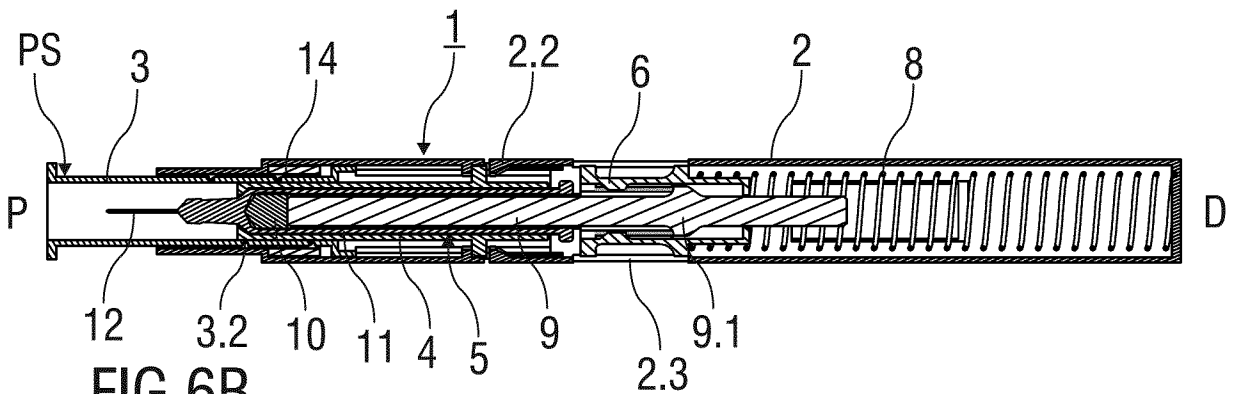

FIG 6B

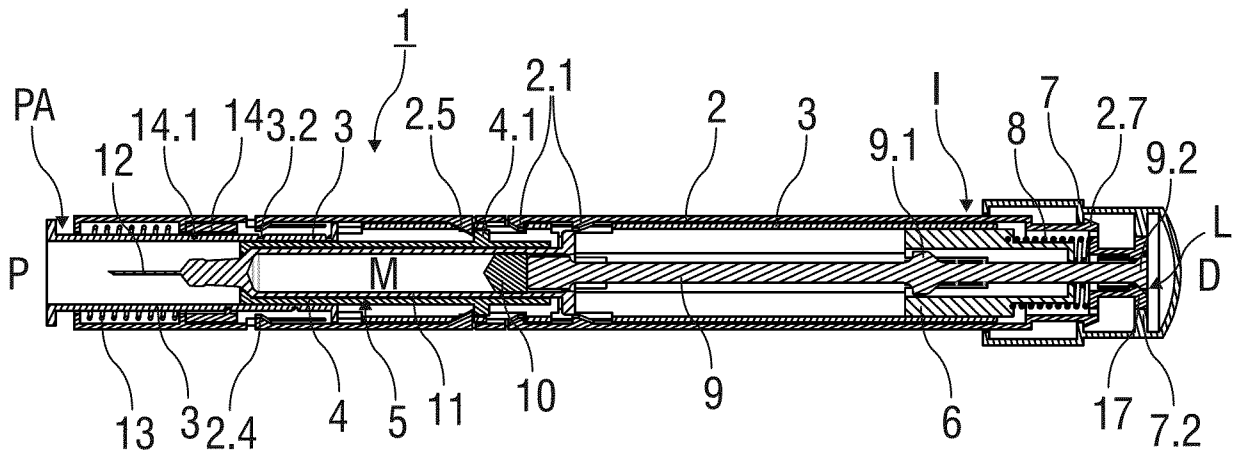

FIG 7A

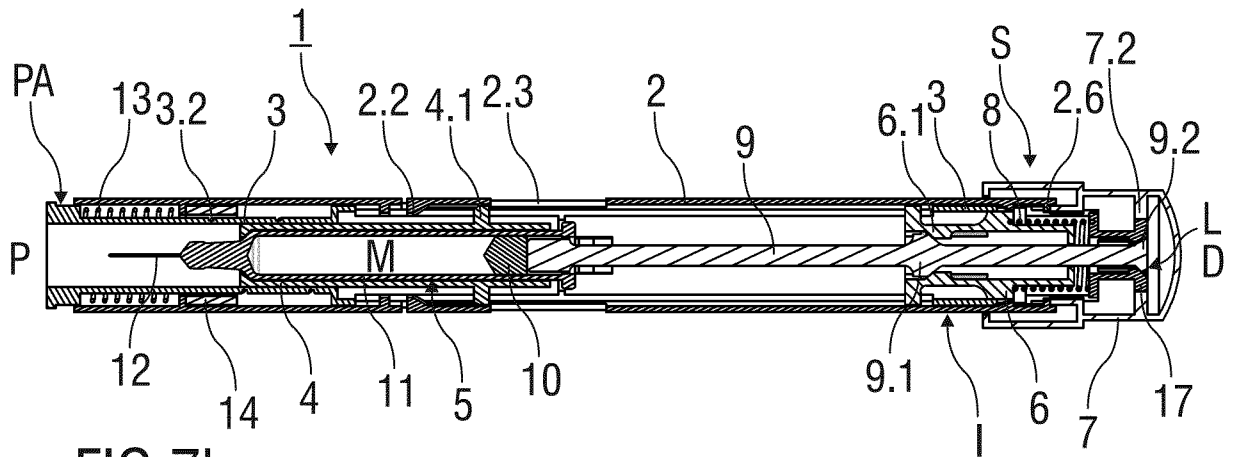

FIG 7b

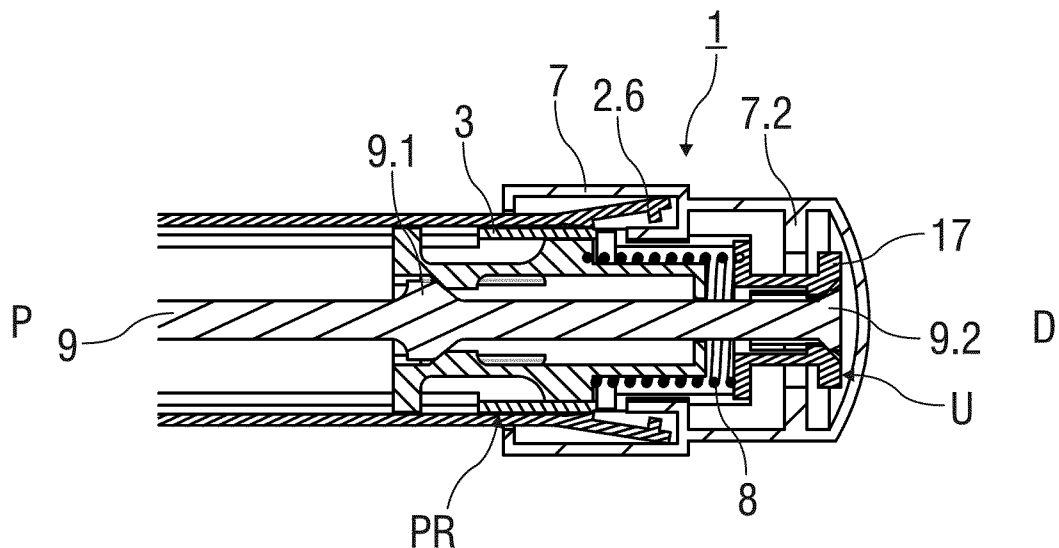

FIG 8

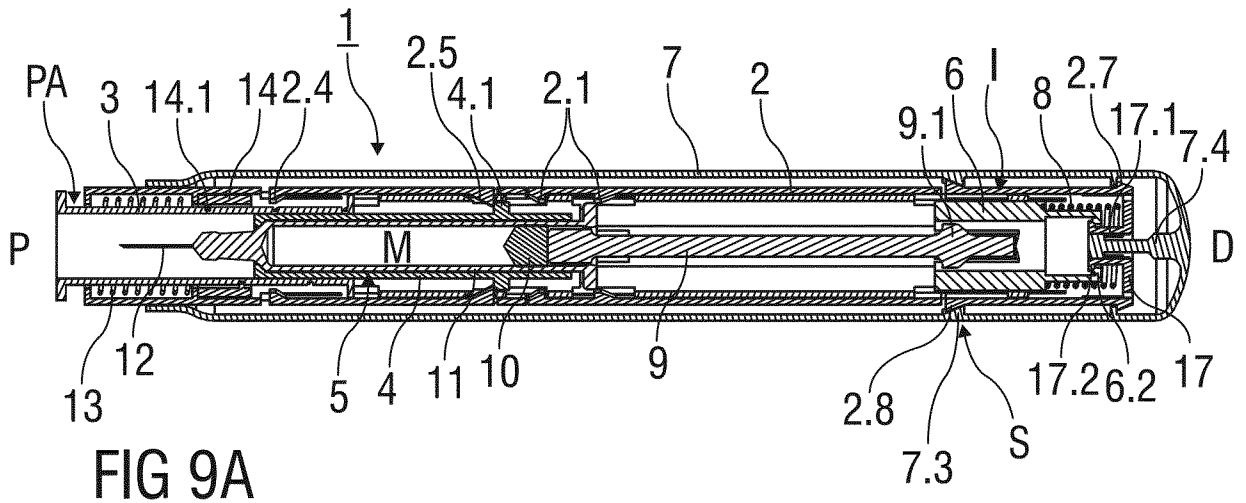

FIG 9A

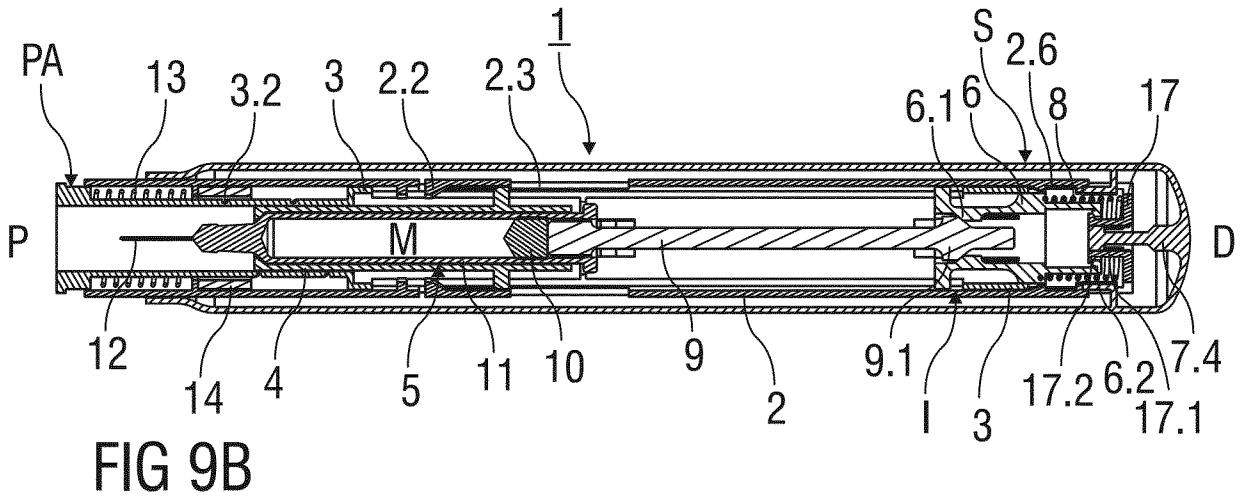

FIG 9B

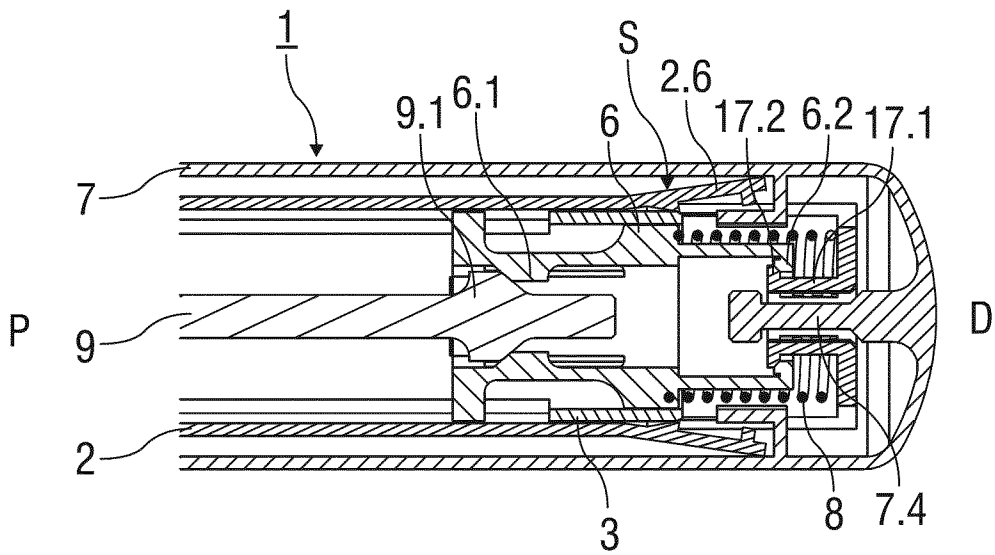

FIG 10

INTERNATIONAL SEARCH REPORT

International application No
PCT/EP2011/073502

A. CLASSIFICATION OF SUBJECT MATTER INV. A61M5/20 A61M5/32 ADD. A61M5/00		
According to International Patent Classification (IPC) or to both national classification and IPC		
B. FIELDS SEARCHED		
Minimum documentation searched (classification system followed by classification symbols) A61M		
Documentation searched other than minimum documentation to the extent that such documents are included in the fields searched		
Electronic data base consulted during the international search (name of data base and, where practical, search terms used) EPO-Internal, WPI Data		
C. DOCUMENTS CONSIDERED TO BE RELEVANT		
Category*	Citation of document, with indication, where appropriate, of the relevant passages	Relevant to claim No.
X	WO 2009/062508 A1 (BANG & OLUFSEN MEDICOM AS [DK]; JOHANSEN ESSEN WELDINGH [DK]; RASMUSSE) 22 May 2009 (2009-05-22) figures 1-20 page 7, line 8 - page 12, line 2 -----	1,3-13
X	WO 2009/040602 A1 (BECTON DICKINSON FRANCE [FR]; CARREL FRANK [FR]; PEROT FREDERIC [FR]) 2 April 2009 (2009-04-02) figures 1-24 paragraph [0087] - paragraph [0106] -----	1-5,13
A	GB 2 438 592 A (CILAG GMBH INT [CH]) 5 December 2007 (2007-12-05) page 4, line 26 - page 8, line 18 figures 1-5 -----	1-13
<input type="checkbox"/> Further documents are listed in the continuation of Box C. <input checked="" type="checkbox"/> See patent family annex.		
* Special categories of cited documents :		
"A" document defining the general state of the art which is not considered to be of particular relevance "E" earlier document but published on or after the international filing date "L" document which may throw doubts on priority claim(s) or which is cited to establish the publication date of another citation or other special reason (as specified) "O" document referring to an oral disclosure, use, exhibition or other means "P" document published prior to the international filing date but later than the priority date claimed		"T" later document published after the international filing date or priority date and not in conflict with the application but cited to understand the principle or theory underlying the invention "X" document of particular relevance; the claimed invention cannot be considered novel or cannot be considered to involve an inventive step when the document is taken alone "Y" document of particular relevance; the claimed invention cannot be considered to involve an inventive step when the document is combined with one or more other such documents, such combination being obvious to a person skilled in the art. "&" document member of the same patent family
Date of the actual completion of the international search 19 March 2012		Date of mailing of the international search report 26/03/2012
Name and mailing address of the ISA/ European Patent Office, P.B. 5818 Patentlaan 2 NL - 2280 HV Rijswijk Tel. (+31-70) 340-2040, Fax: (+31-70) 340-3016		Authorized officer Reinbold, Sylvie

INTERNATIONAL SEARCH REPORT

Information on patent family members

International application No

PCT/EP2011/073502

Patent document cited in search report	Publication date	Patent family member(s)	Publication date
WO 2009062508	A1	22-05-2009	AT 506091 T 15-05-2011
			CN 101909674 A 08-12-2010
			CN 102083486 A 01-06-2011
			EP 2219710 A1 25-08-2010
			EP 2224979 A1 08-09-2010
			EP 2224980 A1 08-09-2010
			US 2010312195 A1 09-12-2010
			US 2011224620 A1 15-09-2011
			US 2011224621 A1 15-09-2011
			WO 2009062508 A1 22-05-2009
			WO 2009062509 A1 22-05-2009
			WO 2009062510 A1 22-05-2009
			WO 2009040602
EP 2217308 A2 18-08-2010			
JP 2010540059 A 24-12-2010			
US 2010268170 A1 21-10-2010			
WO 2009040602 A1 02-04-2009			
WO 2009040672 A2 02-04-2009			
GB 2438592	A	05-12-2007	AT 499960 T 15-03-2011
			AU 2007266804 A1 06-12-2007
			CA 2653328 A1 06-12-2007
			CN 101454036 A 10-06-2009
			DK 2021055 T3 16-05-2011
			EA 200870614 A1 28-04-2009
			EP 2021055 A1 11-02-2009
			ES 2359353 T3 20-05-2011
			GB 2438592 A 05-12-2007
			JP 2009538665 A 12-11-2009
			KR 20090018624 A 20-02-2009
			NZ 573172 A 24-12-2010
			PT 2021055 E 11-04-2011
			WO 2007138319 A1 06-12-2007
			ZA 200810158 A 25-11-2009