

(12) STANDARD PATENT
(19) AUSTRALIAN PATENT OFFICE

(11) Application No. **AU 2009209291 B2**

(54) Title
Introducer sheath assembly with hub and method of joining a hub to sheath tube

(51) International Patent Classification(s)
A61M 25/06 (2006.01) **B29C 65/56** (2006.01)
A61M 25/00 (2006.01)

(21) Application No: **2009209291** (22) Date of Filing: **2009.01.27**

(87) WIPO No: **WO09/097274**

(30) Priority Data

(31) Number	(32) Date	(33) Country
61/062,714	2008.01.29	US

(43) Publication Date: **2009.08.06**

(44) Accepted Journal Date: **2014.05.22**

(71) Applicant(s)
Medical Components, Inc.

(72) Inventor(s)
Spence, Trevor; Nardeo, Mahase

(74) Agent / Attorney
Freehills Patent Attorneys, Level 43 101 Collins Street, Melbourne, VIC, 3000

(56) Related Art
FR 2041652 A
US 2005/0049628 A1
US 2005/0033237 A1
US 3903887 A

(19) World Intellectual Property Organization
International Bureau



(43) International Publication Date
6 August 2009 (06.08.2009)

(10) International Publication Number
WO 2009/097274 A3

(51) International Patent Classification:

A61M 25/06 (2006.01) B29C 65/56 (2006.01)
A61M 25/00 (2006.01)

(21) International Application Number:

PCT/US2009/032121

(22) International Filing Date:

27 January 2009 (27.01.2009)

(25) Filing Language:

English

(26) Publication Language:

English

(30) Priority Data:

61/062,714 29 January 2008 (29.01.2008) US

(71) Applicant (for all designated States except US): **MEDICAL COMPONENTS, INC.** [US/US]; 1499 Delp Drive, Harleysville, PA 19438 (US).

(72) Inventors: **NARDEO, Mahase**; 3842 Ashley Court, Collegeville, PA 19426 (US). **SPENCE, Trevor**; 131 River Bend Park, Lancaster, PA 17602 (US).

(74) Agent: **NESS, Anton, P.**; Fox Rothschild LLP, 2000 Market Street, 10th Floor, Philadelphia, PA 19103 (US).

(81) Designated States (unless otherwise indicated, for every kind of national protection available): AE, AG, AL, AM, AO, AT, AU, AZ, BA, BB, BG, BH, BR, BW, BY, BZ,

CA, CH, CN, CO, CR, CU, CZ, DE, DK, DM, DO, DZ, EC, EE, EG, ES, FI, GB, GD, GE, GH, GM, GT, HN, HR, HU, ID, IL, IN, IS, JP, KE, KG, KM, KN, KP, KR, KZ, LA, LC, LK, LR, LS, LT, LU, LY, MA, MD, ME, MG, MK, MN, MW, MX, MY, MZ, NA, NG, NI, NO, NZ, OM, PG, PH, PL, PT, RO, RS, RU, SC, SD, SE, SG, SK, SL, SM, ST, SV, SY, TJ, TM, TN, TR, TT, TZ, UA, UG, US, UZ, VC, VN, ZA, ZM, ZW.

(84) Designated States (unless otherwise indicated, for every kind of regional protection available): ARIPO (BW, GH, GM, KE, LS, MW, MZ, NA, SD, SL, SZ, TZ, UG, ZM, ZW), Eurasian (AM, AZ, BY, KG, KZ, MD, RU, TJ, TM), European (AT, BE, BG, CH, CY, CZ, DE, DK, EE, ES, FI, FR, GB, GR, HR, HU, IE, IS, IT, LT, LU, LV, MC, MK, MT, NL, NO, PL, PT, RO, SE, SI, SK, TR), OAPI (BF, BJ, CF, CG, CI, CM, GA, GN, GQ, GW, ML, MR, NE, SN, TD, TG).

Published:

- with international search report (Art. 21(3))
- before the expiration of the time limit for amending the claims and to be republished in the event of receipt of amendments (Rule 48.2(h))

(88) Date of publication of the international search report:

29 October 2009

(54) Title: INTRODUCER SHEATH ASSEMBLY WITH HUB AND METHOD OF JOINING A HUB TO SHEATH TUBE

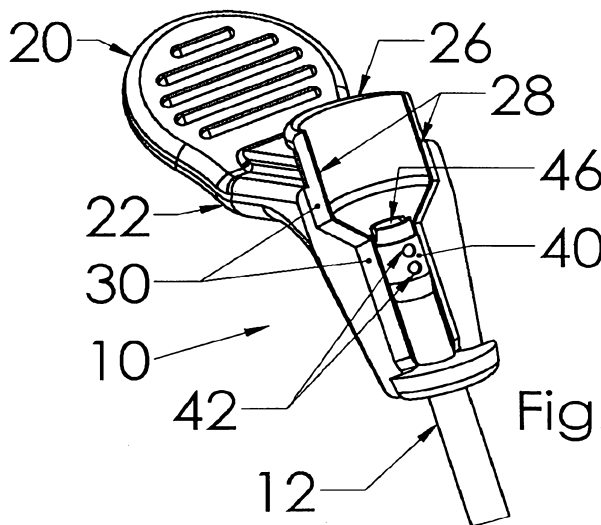

Fig. 5

(57) Abstract: A tearaway introducer sheath assembly (10) for use in implantation of a catheter into a patient, having an elongated polytetrafluoroethylene sheath tube (12) and a proximal polyethylene hub component (16). The hub comprises two halves (22) insert molded about the sheath tube proximal end and joined to each other by frangible webs (28) enabling manual splitting. At least one pair of opposed holes (42) is formed through the tube proximal end portion 44, and a polyethylene liner (46) is inserted into the tube's proximal end portion. The polyethylene flows into the at least one pair of holes (42) to fuse with the liner, establishing a pair of physical joints (50') integrally joining the liner (46) to a respective hub half (22). Upon manual splitting of the hub halves, the sheath tube easily splits along its length as a result of a property of the polytetrafluoroethylene material.

WO 2009/097274 A3

TITLE

Introducer Sheath Assembly with Hub and Method of Joining a Hub to a Sheath Tube

FIELD OF THE INVENTION

[0001] This relates to the field of medical devices, and more particularly to flexible medical tubing and components affixed thereto.

BACKGROUND OF THE INVENTION

[0002] Catheters are often used for the delivery and withdrawal of fluids to and from a blood vessel in a patient, respectively. The fluids may be medication that is administered to the patient, or blood that is withdrawn from the patient. The catheter may also be used for hemodialysis, in which blood is withdrawn from the patient, purified and returned simultaneously through respective lumens of the catheter, and much of the catheter remains within the patient's vasculature for an extended period of time for repeated treatments.

[0003] Typically, to insert a catheter into a blood vessel, the blood vessel is located by known methods. An aspirating needle is inserted into the vessel to confirm placement within the vessel. A guide wire is then inserted through a proximal end of the aspirating needle and into the vessel. The aspirating needle is withdrawn by sliding the needle proximally over the guide wire, leaving the guide wire within the vessel. If a catheter with a sufficiently hard wall is being used, the catheter may be slid over the guide wire, directly into the vessel.

[0004] However, for some catheters, particularly soft walled catheters, a dilator is required to dilate the vessel at the insertion point in order to accommodate the insertion of the catheter. The dilator is typically inserted into a sheath and initially used as a dilator and sheath assembly. The

assembly is inserted into the vessel over the guide wire and the dilator is used to dilate the insertion opening in the vessel wall. After the insertion opening is dilated, the dilator and the guide wire are removed from the vessel by removing both the dilator and the guide wire proximally from the sheath. The sheath remains in the vessel to accommodate insertion of the catheter through the sheath and into the blood vessel.

[0005] Additionally, splittable introducer sheaths are known, wherein the sheath can be easily removed from around a catheter assembly inserted therein and into the patient's vasculature. Typically, such assemblies include manually grippable tabs or wings at the proximal end of the sheath hub that can be pried apart to initiate splitting of the hub and the attached sheath tube apart while simultaneously pulling it proximally along the catheter and out of the patient.

[0006] Conventionally, introducer sheaths have hubs affixed to their proximal ends to which the dilator hub is locked during preparation of the vessel insertion opening. It has become desired for the sheath to be of polytetrafluoroethylene, while the hub material is a different plastic material such as polyethylene. It is known the polytetrafluoroethylene, or PTFE, is notoriously difficult to bond to other plastic materials, so it remains problematic to configure methods and manners of securing the hub to the sheath.

[0007] It is desired to provide a simplified method of securing a hub to a PTFE sheath proximal end.

[0008] It is further desirable to provide a simplified method of securing a hub to a PTFE sheath proximal end, where the introducer sheath assembly is splittable and the hub component halves must remain affixed to respective halves of the sheath during splitting.

[0008A] Reference to any prior art in the specification is not, and should not be taken as, an acknowledgment or any form of suggestion that this prior art forms part of the common

general knowledge in Australia or any other jurisdiction or that this prior art could reasonably be expected to be ascertained, understood and regarded as relevant by a person skilled in the art.

[0008B] As used herein, except where the context requires otherwise the term ‘comprise’ and variations of the term, such as ‘comprising’, ‘comprises’ and ‘comprised’, are not intended to exclude other additives, components, integers or steps.

BRIEF SUMMARY OF THE INVENTION

[0008C] In a first aspect the invention provides an introducer sheath assembly having an elongated sheath tube of a first material having a distal end, a proximal end and a proximal end portion, and a hub positioned at the proximal end portion of the sheath tube , characterized in that:

the hub is insert-molded of a second material different from the first material, about the proximal end portion of the sheath tube and includes an interior lining portion extending along an inside surface of the sheath tube proximal end, the interior lining portion being of a material identical to or at least sufficiently compatible with the second material to form an integral joint therewith,

whereafter joints of the second material integrally join the hub to the interior lining portion through respective holes through the sheath tube adjacent the sheath tube proximal end thereby joining the hub to the elongated sheath tube.

[0008D] In a second aspect the invention provides a method of forming an introducer sheath assembly, comprising the steps of:

providing an elongated sheath tube having a proximal end portion and having at least one pair of opposed holes therethrough adjacent the proximal end; and

molding a hub to the sheath tube proximal end portion, the hub being integrally joined to an interior lining portion within the sheath tube proximal end portion through the at least one pair of

opposed holes, wherein the sheath tube is formed of a first material, the hub is formed of a second, dissimilar material, and wherein the interior lining portion is a liner preformed of a third material different from the first material but at least compatible with the second material.

[0009] Briefly, the present invention advantageously provides a method of forming an assured joint between a tube of a first plastic material and a component of a second plastic material incompatible with the first plastic material. The method comprises the steps of: providing a tube of a first plastic material and having a proximal end through which are formed at least one pair of holes on opposed sides and generally aligned with each other; providing an interior lining portion of a second plastic material different from the first material, such as a preformed liner being inserted into the tube proximal end for the liner to underlie the at least one pair of holes; and molding around the tube proximal end a component of the second plastic material or a third material at least compatible with the second material such that a bond would form therebetween during molding, whereby the material of the component protrudes through the at least one pair of holes and fuses or bonds to the material of the liner, thereby establishing joints that extend through the holes of the tube and affix both the component and the liner to the tube.

[0010] In one practical embodiment, the method provides an assured joint of an introducer sheath tube of polytetrafluoroethylene (PTFE) and a liner and a hub component (or components) of a different plastic such as polyethylene.

[0011] It may be desirable to provide an expanded inner diameter to the tube's proximal end, such that the liner may have an inner diameter substantially equal to the inner diameter of the remainder of the tube. Optionally, an array of two or more holes may be provided along each side of the tube proximal end for a stronger joint between the component and the tube.

[0012] In one embodiment an introducer assembly of the present invention may be made using the present inventive method where the hub component is molded to the sheath tube proximal

2009209291 14 Mar 2014

end, where the hub comprises two halves initially joined to each other at frangible seams along opposite sides of the sheath tube, such that the hub component can be easily split for easy removal of the introducer

sheath assembly from a catheter after insertion into a patient. The sheath tube has at least one pair of holes adjacent the proximal end through which the hub halves are formed with joints extending through the sheath tube holes affixing them to a liner within the sheath tube, so that each hub half remains assuredly affixed to a respective side of the sheath tube. Also, preferably, the liner includes a proximal end portion protruding beyond the sheath tube proximal end to which the hub component integrally joins, as well, and may include notches into the proximal end to initiate eventual sheath assembly splitting. The introducer sheath tube has inherent lines of weakness, and additionally may have slits partially therealong, to continue the splitting entirely along the sheath tube, resulting from the PTFE material. Other sheath tube materials may be used but scoring of an opposed pair of seams therealong would be expected to be provided to facilitate sheath tube splitting.

[0013] In an alternate method of the invention, a preformed liner is not utilized. Instead, the proximal end of the sheath tube is expanded as before, with at least one pair of opposed holes formed therethrough, and the proximal sheath end is placed into a mold. With appropriately adapted mandrels extending through the sheath tube, a relatively thin gap, optionally annular, is provided between the mandrel and the inner diameter of the expanded proximal sheath end at least adjacent to and underlying the opposed holes. When the hub component is molded to the sheath end, mold material flows through the opposed holes and into the gap, and preferably for a limited distance along the mandrel proximally of the sheath tube proximal end as well, thereby forming an inner liner thereafter integrally joined to the outer hub halves.

BRIEF DESCRIPTION OF THE DRAWINGS

[0014] The accompanying drawings, which are incorporated herein and constitute part of this specification, illustrate the presently preferred embodiments of the invention, and, together with

the general description given above and the detailed description given below, serve to explain the features of the invention. In the drawings:

[0015] Fig. 1 is an isometric view of an introducer sheath assembly of the present invention;

[0016] Fig. 2 is an enlarged isometric view of the proximal end of the assembly of Fig. 1 with a dilator removably secured thereto at the proximal end;

[0017] Fig. 3 is an enlarged view of the proximal end of the assembly of Fig. 1 showing the frangible webs between the hub halves and the related grooves associated with the frangible webs;

[0018] Fig. 4 is a partially sectioned view of the assembly of Fig. 1 with one hub half mostly removed;

[0019] Fig. 5 is an enlarged view of the proximal end of the assembly of Fig. 4 with one hub half removed and in which the thin frangible web is shown sectioned;

[0020] Fig. 6 is an enlarged distally facing cross-sectioned view of the hub halves separate from the sheath tube, illustrating the frangible webs and related grooves;

[0021] Figs. 7 and 8 are isometric views showing a liner being inserted into the sheath tube proximal end and then in position in the sheath proximal end;

[0022] Fig. 9 is a representation longitudinal view of the proximal end of the sheath tube and liner with a hub molded thereto to illustrate the joints that extend through the opposed holes;

[0023] Fig. 10 is an enlarged cross-sectional view of the introducer assembly of the present invention after molding of the hub component, in which the liner is seen protruding from the sheath tube joined to the hub component by joints extending through the opposed holes;

[0024] Fig. 11 is an isometric enlarged view of an alternate embodiment of a sheath proximal end with a liner positioned therein, wherein the sheath and liner include complementary ears utilized to properly orient the liner angularly with the sheath tube, for the liner score lines to be

aligned with respective notches in the sheath tube proximal end to facilitate initiation of eventual splitting; and

[0025] Fig. 12 is an enlarged view of the proximal sheath end without a liner, and associated mandrel that defines an annular gap within the expanded sheath end, for molding a hub component to the sheath end without use of a preformed liner component.

DETAILED DESCRIPTION OF THE INVENTION

[0026] In the drawings, like numerals indicate like elements throughout. Certain terminology is used herein for convenience only and is not to be taken as a limitation on the present invention. The terms “distal” and “proximal” refer, respectively, to directions closer to and away from the insertion tip of a catheter in an implantable catheter assembly. The terminology includes the words specifically mentioned, derivatives thereof and words of similar import. The embodiments illustrated below are not intended to be exhaustive or to limit the invention to the precise form disclosed. These embodiments are chosen and described to best explain the principle of the invention and its application and practical use and to enable others skilled in the art to best utilize the invention.

[0027] In Figure 1, introducer assembly 10 of the present invention includes an elongate sheath tube 12 having a distal end 14, with a hub component 16 affixed to the proximal tube end. Hub component 16 is designed to be manually split, having a body 18 with a pair of tabs 20 each of which is associated with a hub half 22. Fig. 2 shows a dilator 24 in position removably secured to the proximal end portion 26 of the hub component 16 for insertion of distal sheath tube end 14 into an incision into the blood vessel (not shown), after which the dilator 24 will be removed and the distal end of a catheter (not shown) then inserted into the introducer assembly 10. Splitting of the hub component 16 into respective halves 22 is performed after the catheter assembly's distal end

portion is within the vasculature of the patient and the two halves of the introducer assembly are torn away.

[0028] Now referring to Figures 3 to 6, hub 16 is shown to have two hub halves 22 joined to each other by a pair of frangible webs 28 along opposite sides angularly spaced 90° from radial midlines of tabs 20, and V-shaped grooves 30 extending radially outwardly from the webs 28. This particular structure enables the hub 16 to be easily manually split apart by prying apart the tabs 20.

[0029] The present invention is directed to facilitating the tearing of the elongate introducer sheath simultaneously with the splitting apart of the hub component 16 into respective halves 22. In Figs. 7 to 9 are shown one manner of defining a joint between the elongate sheath tube 12 and the hub component 16, wherein discrete joints are defined between the sheath tube and the respective hub halves 22. The proximal end portion 40 of the sheath tube 12 is enlarged to have a larger inner diameter, and at least one pair of holes 42,42 is punched or otherwise defined on respective opposite sides of the tube adjacent the proximal tube end 44. The hub halves 22 would each be joined to an interior lining portion within the sheath tube proximal end portion 40, by joints through the at least one pair of holes 42,42. In one method, a previously formed tubular liner 46 is inserted into the enlarged proximal end portion 40, with a proximal liner portion 47 projecting beyond the proximal end 44 of the sheath tube. The liner may be provided with a pair of notches 48 on opposite sides at the proximal end of the proximal liner portion 47 (or longitudinal slits or score lines along opposite sides of the liner, as seen in Fig. 11, or both), to facilitate splitting, although the liner may be sufficiently thin that such notches or their equivalents may not be necessary; if provided, they would be offset about 90° from the pair or pairs of holes 42 in the proximal sheath end portion 40.

[0030] Referring to the representation in Figure 9, the hub component would then be insert molded about the proximal sheath tube end 40' having the liner 46' in position within the mold

cavity. The liner would be of a material that is sufficiently compatible, at least, with the material from which the hub would be made, such as polyethylene, that joints 50' would form within holes 42' integral with both the liner 46' and the two hub halves 22', and additionally would bond with the proximal liner portion 47' at annular joint 51' (without filling in notches 48'), and thus assuredly mechanically securing the sheath tube to the hub component thereby.

[0031] The proximal end of the introducer assembly 10 is shown in Figure 10, after the molding of the hub component 16 to the sheath tube 12 and liner 46. A joint 50' is seen protruding through hole 42 to join one of the sheath halves 22 to the liner 46.

[0032] An alternative sheath tube 60 is seen in Figure 11, with an alternative embodiment of liner 70. Expanded proximal sheath tube end 62 includes a pair of proximal projections or ears 64 on opposed sides projecting proximally therefrom. A pair of notches 66 are defined into the proximal end of the sheath tube that will be aligned with frangible webs of the eventual hub component molded thereto, for eventually initiating the splitting of the introducer sheath assembly from a catheter during implantation. Optionally, slits 67 may be defined extending partially along the sheath tube from the notches 66. Holes 68 are formed through the sheath tube exposing the liner 70 therewithin. Liner 70 includes a pair of proximal projections or ears 72 on opposed sides of the proximal liner end portion 74 that can be physically paired with ears 64 of the sheath tube as shown, in order to align score lines 76 (or slits extending partially along the liner) of the liner with notches 66 during introducer sheath assembly manufacturing.

[0033] In a variation of the method described above, and referring to Figure 12, a sheath tube 80 is provided with an enlarged diameter proximal end portion 82, through which at least one pair of opposed holes 84 are formed. A mandrel 86 is inserted through the sheath tube, having an outer diameter equivalent to the inner diameter of the sheath tube, while the expanded proximal sheath end is spaced radially away from the mandrel outer surface. The resultant annular gap 88

permits mold material to fill the holes and form an interior lining portion in the annular gap 88 around the mandrel 86. The mandrel may have pointed longitudinal ridges 90 along opposite sides to define frangible webs in the liner formed during molding, positioned angularly 90° from the location of holes 84,84, all to facilitate eventual splitting during introducer sheath removal.

[0034] Preferably, the hub and an interior lining portion can be simultaneously formed integrally joined together for a limited distance just proximally of the sheath tube proximal end. In a further variation of the method described hereinabove, the proximal hub/interior lining portion joint can be in lieu of providing holes through the sheath tube proximal end.

[0035] By either method, an effective joint is defined between the hub component and the sheath tube at the proximal end, enabling a sheath tube such as of polytetrafluoroethylene material to have a hub component such as of polyethylene material secured thereto. When such a hub component is eventually split after use, the sheath tube will also tear longitudinally as well, for removal of the introducer sheath from around a catheter.

[0036] It will be appreciated by those skilled in the art that changes could be made to the embodiments described above without departing from the broad inventive concept thereof. It is understood, therefore, that this invention is not limited to the particular embodiments disclosed, but it is intended to cover modifications within the scope of the present invention as defined by the appended claims.

14 Mar 2014

2009209291

The claims defining the invention are as follows:

1. An introducer sheath assembly having an elongated sheath tube of a first material having a distal end, a proximal end and a proximal end portion, and a hub positioned at the proximal end portion of the sheath tube , characterized in that:

5 the hub is insert-molded of a second material different from the first material, about the proximal end portion of the sheath tube and includes an interior lining portion extending along an inside surface of the sheath tube proximal end, the interior lining portion being of a material identical to or at least sufficiently compatible with the second material to form an integral joint therewith,

10 whereafter joints of the second material integrally join the hub to the interior lining portion through respective holes through the sheath tube adjacent the sheath tube proximal end thereby joining the hub to the elongated sheath tube.

2. The assembly of claim 1, wherein the interior lining portion has an inner diameter generally equal to a diameter of the sheath tube passageway and the diameter of the sheath tube proximal end
15 portion is expanded for the interior lining portion to be disposed therewithin.

3. The assembly of claim 1, wherein the sheath tube proximal end portion has at least one pair of opposed holes therethrough, resulting in at least one pair of opposed joints extending therethrough, and wherein the hub and the interior lining portion are adapted to be manually split apart into associated halves after insertion of a catheter through the introducer sheath, and the
20 elongated sheath tube is adapted to be split upon splitting of the hub and interior lining portion, and respective ones of the at least one pair of opposed joints are joined to respective ones of the hub/lining portion halves.

4. The assembly of claim 3, wherein the diameter of the sheath tube proximal end portion is expanded, and the liner includes a proximal liner portion projecting proximally from the proximal end portion of the sheath tube after insertion into the thus-enlarged proximal sheath tube end portion, for eventually being integrally joined with the hub upon molding.
5. The assembly of claim 3, wherein the liner includes score lines extending along opposite sides thereof to facilitate the initiation of splitting thereof for eventual sheath removal, and/or wherein the liner includes notches extending distally from the proximal end thereof to facilitate the initiation of splitting thereof for eventual sheath removal.
6. The assembly of claim 3, wherein the sheath tube is formed of polytetrafluoroethylene and the hub and liner are formed of polyethylene.
7. The assembly of claim 3, wherein the sheath tube at least includes notches on opposed sides of the proximal end of the proximal portion and further includes proximal projections from the proximal end angularly spaced about 90° from the notch locations, and wherein the liner includes corresponding proximal projections extending from the proximal end thereof similarly angularly spaced about 90° from score lines extending therealong on opposed sides, facilitating appropriate angular orientation between the sheath tube and the liner during molding of the hub component thereto, all to facilitate eventual splitting of the introducer assembly.
8. The assembly of claim 1, wherein the sheath tube proximal end portion has at least two pairs of opposed holes therethrough, resulting in at least two pairs of opposed joints.
9. A method of forming an introducer sheath assembly, comprising the steps of:
providing an elongated sheath tube having a proximal end portion and having at least one pair of opposed holes therethrough adjacent the proximal end; and

molding a hub to the sheath tube proximal end portion, the hub being integrally joined to an interior lining portion within the sheath tube proximal end portion through the at least one pair of opposed holes, wherein the sheath tube is formed of a first material, the hub is formed of a second, dissimilar material, and wherein the interior lining portion is a liner preformed of a third material different from the first material but at least compatible with the second material.

10. The method of claim 9, wherein the first material is polytetrafluoroethylene and the second material is polyethylene.

11. The method of claim 9, wherein at least the hub is formed to have an opposed pair of frangible webs enabling manual splitting thereof into respective halves to remove the introducer sheath assembly from around a catheter inserted therethrough during catheter implantation into a patient, and wherein the interior lining portion is a liner pre-formed and includes longitudinal score lines along opposed sides thereof, or notches into the proximal end thereof, or both, for alignment with the frangible webs of the hub, to facilitate manual splitting thereof during splitting of the assembly.

12. The method of claim 9, wherein the hub is further integrally joined to an interior lining portion within the sheath tube proximal end portion at least just proximally of the sheath tube proximal end.

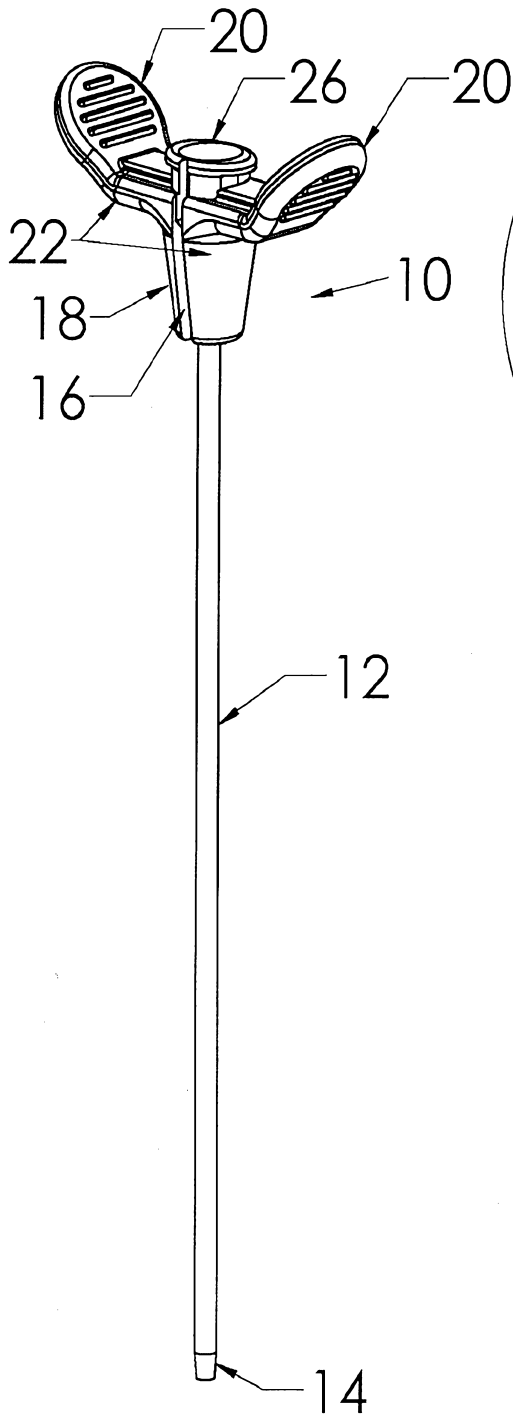

Fig. 1

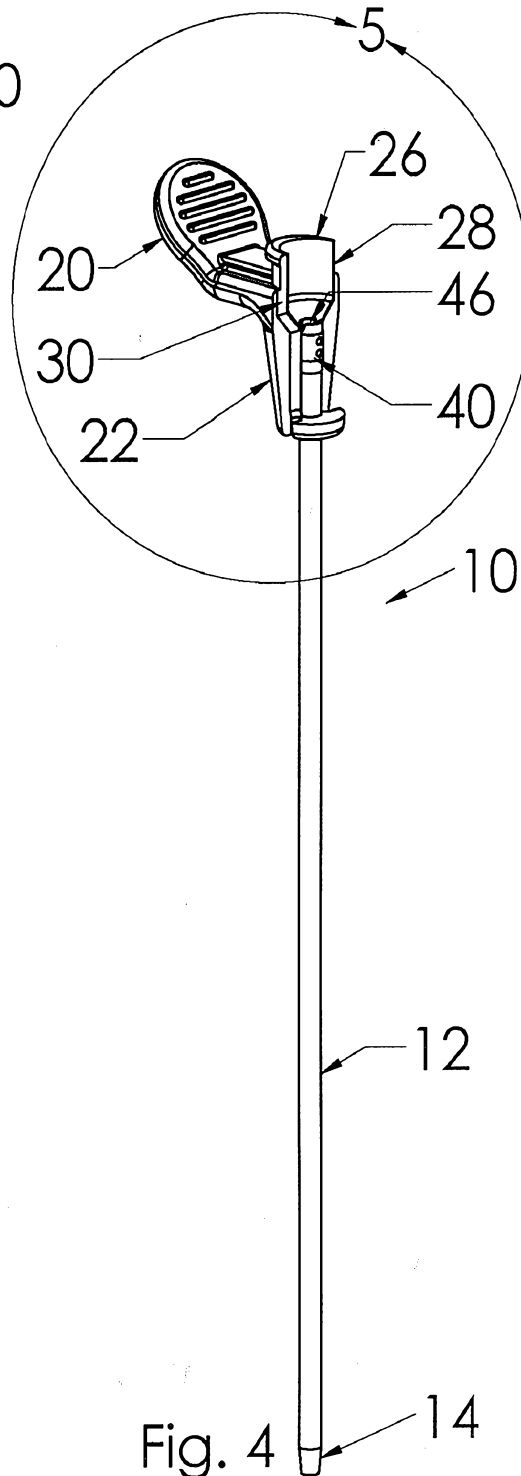
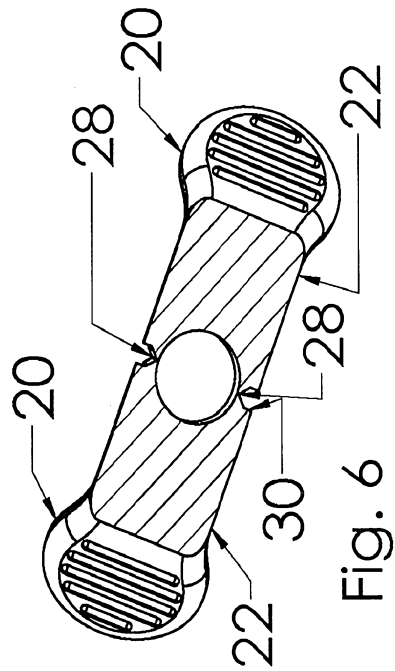
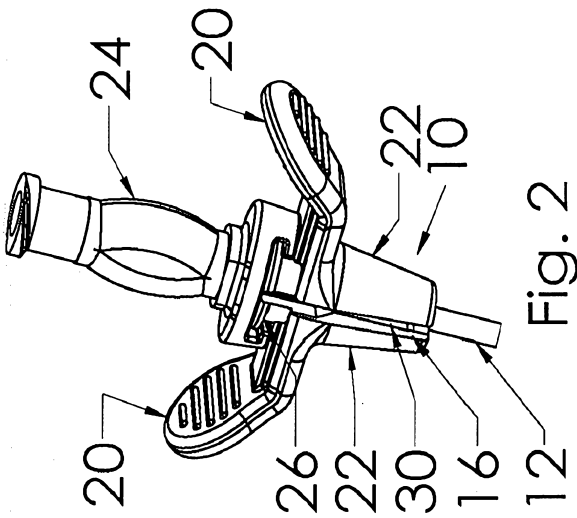
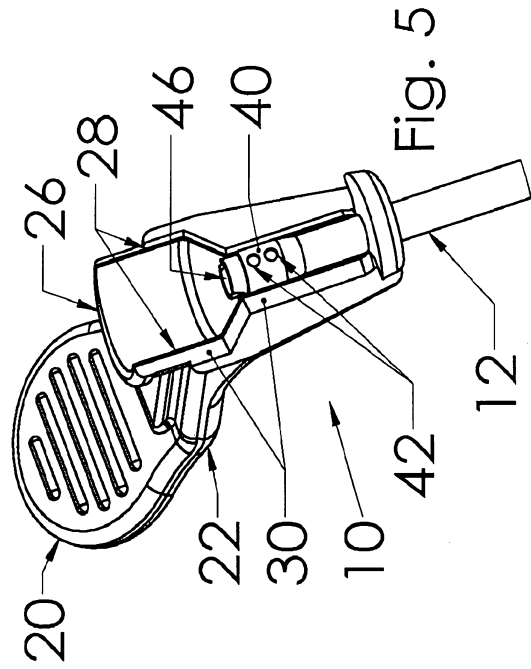
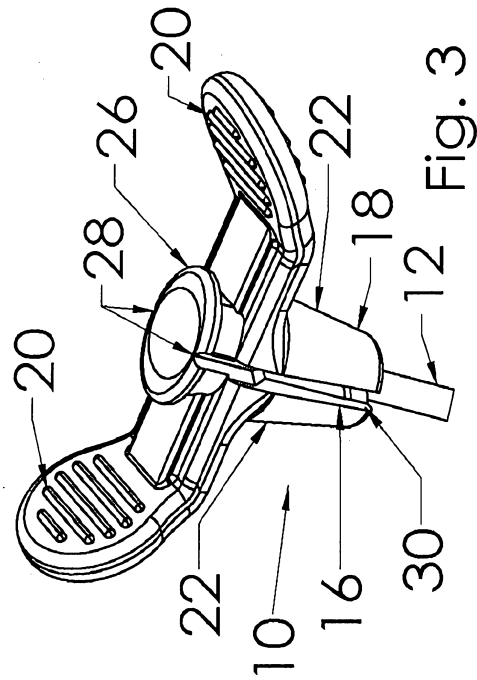

Fig. 4



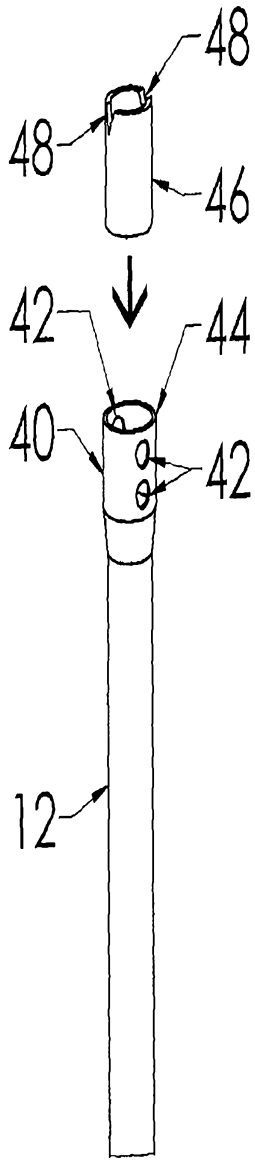

Fig. 7

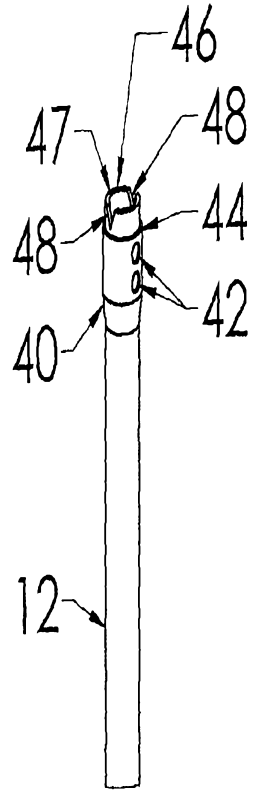

Fig. 8

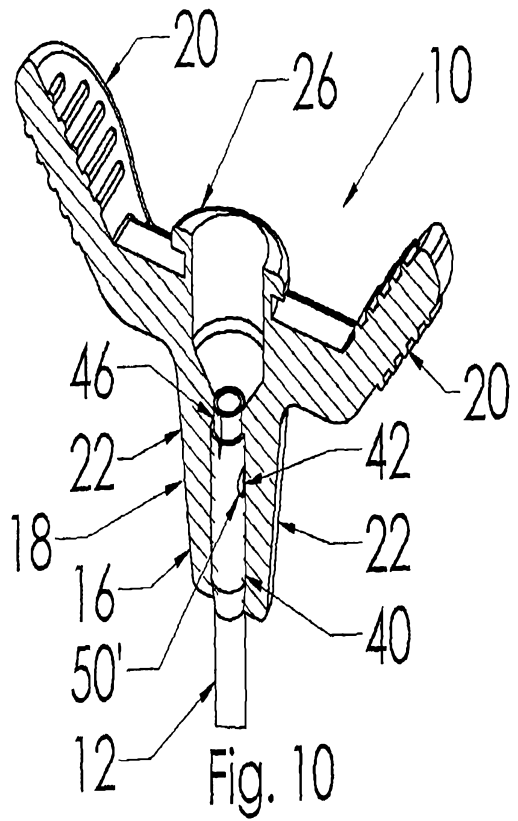

Fig. 10

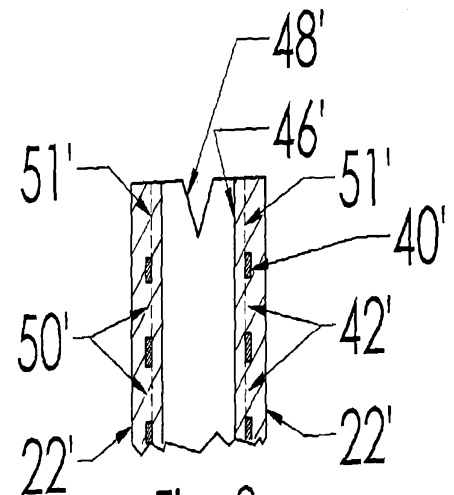

Fig. 9

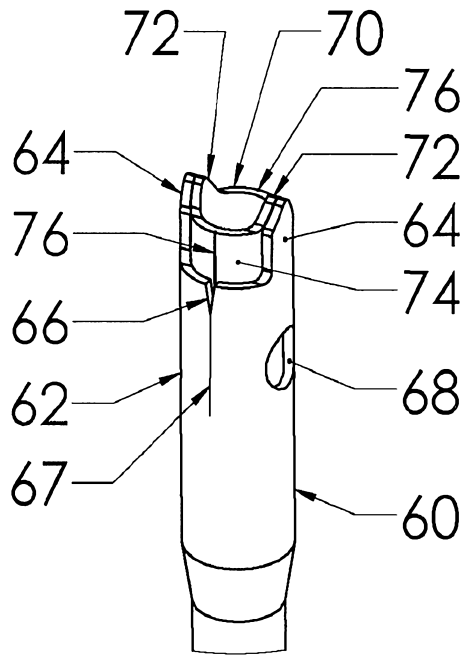

Fig. 11

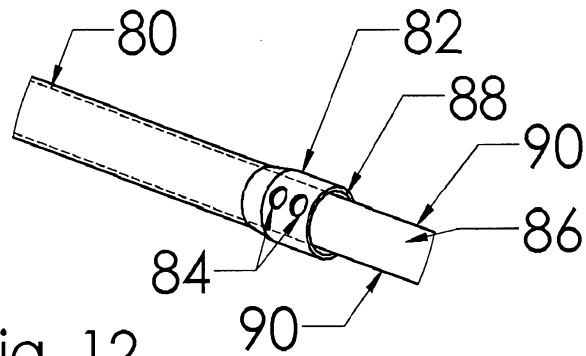

Fig. 12