



(12) **United States Design Patent**  
**Mitchell**

(10) **Patent No.:** **US D812,050 S**  
(45) **Date of Patent:** **\*\* Mar. 6, 2018**

- (54) **COORDINATE INPUT DEVICE**
- (71) Applicant: **Wacom Co., Ltd.**, Kazo-shi, Saitama (JP)
- (72) Inventor: **Giles Thomas Mitchell**, Setagaya-ku (JP)
- (73) Assignee: **Wacom Co., Ltd.**, Kazo-shi (JP)
- (\*\*) Term: **15 Years**
- (21) Appl. No.: **29/601,739**
- (22) Filed: **Apr. 25, 2017**
- (30) **Foreign Application Priority Data**

Dec. 21, 2016 (JP) ..... 2016-027749

- (51) **LOC (11) Cl.** ..... **14-02**
- (52) **U.S. Cl.**  
USPC ..... **D14/341**
- (58) **Field of Classification Search**  
USPC ..... D14/125–134, 159, 239, 341, 342, 346,  
D14/347, 336, 371, 374–377, 420, 426,  
(Continued)

(56) **References Cited**

**U.S. PATENT DOCUMENTS**

- 6,462,733 B1 \* 10/2002 Murakami ..... G06F 3/033  
345/156
- D558,756 S 1/2008 Andre et al.  
(Continued)

**FOREIGN PATENT DOCUMENTS**

- CN 301234784 S 5/2010
- CN 301426022 12/2010
- CN 302630632 11/2013
- CN 302630692 11/2013
- CN 302748482 S 2/2014  
(Continued)

**OTHER PUBLICATIONS**

The new Wacom Intuos pro review 2017, announced May 27, 2017 [online], [site visited Jun. 20, 2017]. Available from Internet, URL: <<http://sweetmonia.com/Sweet-Drawing-Blog/the-new-wacom->

intuos-pro-review-2017-medium-large-pth-660p-pth-860p-including-the-new-paper-edition-pth-860p-pth-660p/>.\*  
Wacom Intuos pro review—Which Tablet Size Right for You, announced Oct. 10, 2014 [online], [site visited Jun. 20, 2017]. Available from Internet, URL: <<http://sweetmonia.com/Sweet-Drawing-Blog/intuos-pro-review-which-tablet-is-the-right-for-you/>>.\*

(Continued)

*Primary Examiner* — Barbara Fox  
*Assistant Examiner* — Dana K Weiland  
(74) *Attorney, Agent, or Firm* — Christensen O'Connor Johnson Kindness PLLC

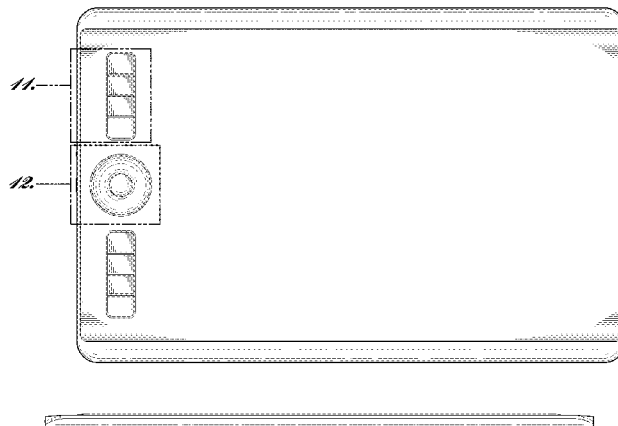
(57) **CLAIM**

The ornamental design for a coordinate input device, as shown and described.

**DESCRIPTION**

FIG. 1 is a front bottom left perspective view of a coordinate input device showing my new design; FIG. 2 is a rear top right view thereof; FIG. 3 is a front view thereof; FIG. 4 is a rear view thereof; FIG. 5 is a top view thereof; FIG. 6 is a bottom view thereof; FIG. 7 is a left side view thereof; FIG. 8 is a right side view thereof; FIG. 9 is an enlarged view of a portion of the coordinate input device shown in FIG. 1; FIG. 10 is an enlarged view of a portion of the coordinate input device shown in FIG. 2; FIG. 11 an enlarged view of a portion of the coordinate input device shown in FIG. 3; and, FIG. 12 is an enlarged view of a portion of the coordinate input device shown in FIG. 3.  
The dashed broken lines in the drawings show portions of the coordinate input device that form no part of the claimed design. The dot-dot-dash broken lines in the drawings indicate from where the enlarged views are taken and form no part of the claimed design.

**1 Claim, 9 Drawing Sheets**



(58) **Field of Classification Search**

USPC .... D14/440, 448, 450, 496, 138 R, 138 AA,  
 D14/138 G, 147, 203.1–203.7, 247, 388,  
 D14/389; D6/300–310; D16/241;  
 D20/10, 19, 39; D21/329, 333, 331, 332  
 CPC .. G06F 1/1613; G06F 3/04883; G06F 1/1647;  
 G06F 3/04845; G06F 1/1601; G06F  
 1/1643; A63H 33/3016; H04M 1/0279;  
 H04M 1/0281; H04M 1/0283; H05K  
 5/0004; H05K 5/0017; H05K 5/02; H05K  
 5/0217; H04N 13/0459

See application file for complete search history.

## (56)

**References Cited**

## U.S. PATENT DOCUMENTS

D580,387 S 11/2008 Andre et al.  
 D585,037 S \* 1/2009 Drozdenko ..... D14/203.1  
 D590,381 S \* 4/2009 Laine ..... D14/247  
 D600,241 S 9/2009 Andre et al.  
 D601,135 S \* 9/2009 Stone ..... D14/247  
 D604,297 S 11/2009 Andre et al.  
 D617,762 S 6/2010 Hong et al.  
 D620,003 S 7/2010 Chiang et al.  
 D622,689 S 8/2010 Ho et al.  
 D625,727 S 10/2010 Crisp et al.  
 D625,728 S 10/2010 Crisp et al.  
 D627,778 S 11/2010 Akana et al.  
 D629,400 S 12/2010 Harper  
 D629,401 S 12/2010 Crisp et al.  
 D629,402 S 12/2010 Crisp et al.  
 D631,047 S 1/2011 Hirota  
 D636,390 S 4/2011 Andre et al.  
 D636,768 S 4/2011 Chan et al.  
 D637,597 S \* 5/2011 Seong ..... D14/346  
 D638,396 S \* 5/2011 Finnegan ..... D14/203.3  
 D642,174 S \* 7/2011 Hirota ..... D14/374  
 D642,563 S 8/2011 Akana et al.  
 D648,723 S 11/2011 Harper et al.  
 D662,094 S 6/2012 Mack et al.  
 D670,287 S \* 11/2012 Shimizu ..... D14/341  
 8,390,272 B2 \* 3/2013 Yokota ..... G06F 3/0416  
 178/18.06  
 D681,032 S 4/2013 Akana et al.  
 D681,056 S 4/2013 Akana et al.  
 D681,632 S 5/2013 Akana et al.  
 D684,571 S 6/2013 Akana et al.  
 D687,826 S 8/2013 Jeon et al.  
 D688,239 S 8/2013 Chiang  
 D689,482 S 9/2013 Akana et al.  
 D689,487 S 9/2013 Halsinger et al.  
 D689,488 S 9/2013 Halsinger et al.  
 D689,489 S 9/2013 Halsinger et al.  
 D689,490 S 9/2013 Halsinger et al.  
 D689,491 S 9/2013 Halsinger et al.  
 D689,492 S 9/2013 Halsinger et al.  
 D689,499 S \* 9/2013 Chen ..... D14/440  
 D689,856 S 9/2013 Shen  
 D690,696 S 10/2013 Jonsson et al.  
 D690,697 S 10/2013 Jonsson et al.  
 D690,698 S 10/2013 Jonsson et al.  
 D690,699 S 10/2013 Jonsson et al.  
 D690,700 S 10/2013 Jonsson et al.  
 D690,701 S 10/2013 Jonsson  
 D693,333 S \* 11/2013 Joe ..... D14/218  
 D694,211 S 11/2013 Yuu et al.  
 D698,352 S 1/2014 Andre et al.  
 D698,783 S 2/2014 Hong  
 D702,233 S \* 4/2014 Lee ..... D14/341  
 D702,235 S \* 4/2014 Jonsson ..... D14/390  
 D706,300 S 6/2014 Akana et al.  
 D706,301 S 6/2014 Akana et al.  
 D706,302 S 6/2014 Akana et al.  
 D707,223 S 6/2014 Akana et al.  
 D709,077 S 7/2014 Jonsson et al.

D716,798 S 11/2014 Kurimoto et al.  
 D716,799 S 11/2014 Green et al.  
 D719,150 S 12/2014 Daniel  
 D719,161 S 12/2014 Huebner  
 D722,055 S 2/2015 Jonsson et al.  
 D725,180 S 3/2015 Azuma  
 D725,181 S 3/2015 Azuma  
 D725,650 S 3/2015 Satzger et al.  
 D725,651 S 3/2015 Green et al.  
 D731,481 S 6/2015 Akana et al.  
 D733,710 S 7/2015 Huebner  
 D736,763 S 8/2015 Yum et al.  
 9,143,127 B2 \* 9/2015 Tamura ..... H03K 17/962  
 D740,281 S 10/2015 Kim et al.  
 D743,391 S 11/2015 Akana et al.  
 D743,931 S 11/2015 Hubbard et al.  
 D744,480 S 12/2015 Kim  
 D744,484 S \* 12/2015 Huebner ..... D14/389  
 D745,004 S 12/2015 Kim  
 D746,281 S 12/2015 Kim et al.  
 D747,310 S 1/2016 Akana et al.  
 D748,090 S 1/2016 Kim et al.  
 D748,091 S 1/2016 Akana et al.  
 D748,621 S 2/2016 Akana et al.  
 D749,575 S 2/2016 Park et al.  
 D750,620 S 3/2016 Zhai  
 D753,101 S 4/2016 Akana et al.  
 D753,104 S 4/2016 Kim et al.  
 D753,105 S 4/2016 Chang et al.  
 D754,124 S 4/2016 Kim et al.  
 D754,125 S 4/2016 Akana et al.  
 D756,354 S 5/2016 Katsumata  
 D756,995 S 5/2016 Yamazaki et al.  
 D756,997 S 5/2016 Lai et al.  
 D758,361 S 6/2016 Yeo et al.  
 D759,008 S 6/2016 Akana et al.  
 D760,197 S \* 6/2016 Huebner ..... D14/218  
 D760,217 S 6/2016 Akana et al.  
 D760,715 S 7/2016 Chang et al.  
 D762,207 S 7/2016 Akana et al.  
 D762,640 S 8/2016 Yamazaki et al.  
 D763,252 S 8/2016 Lee et al.  
 D763,846 S 8/2016 Lee  
 D770,444 S 11/2016 Ho et al.  
 D771,034 S 11/2016 Satzger et al.  
 D775,096 S 12/2016 Kim et al.  
 D775,125 S \* 12/2016 Yoshihara ..... D14/341  
 D779,480 S 2/2017 Abrams  
 D780,175 S 2/2017 Jung et al.  
 D780,748 S 3/2017 Wang et al.  
 D781,285 S 3/2017 Akana et al.  
 D781,846 S \* 3/2017 Hasegawa ..... D14/341  
 D782,469 S 3/2017 Raken et al.  
 D783,603 S 4/2017 Satzger et al.  
 D784,980 S \* 4/2017 Lin ..... D14/341  
 2013/0161179 A1 \* 6/2013 Tamura ..... H03K 17/962  
 200/600  
 2014/0263930 A1 \* 9/2014 Huebner ..... F16M 11/10  
 248/558

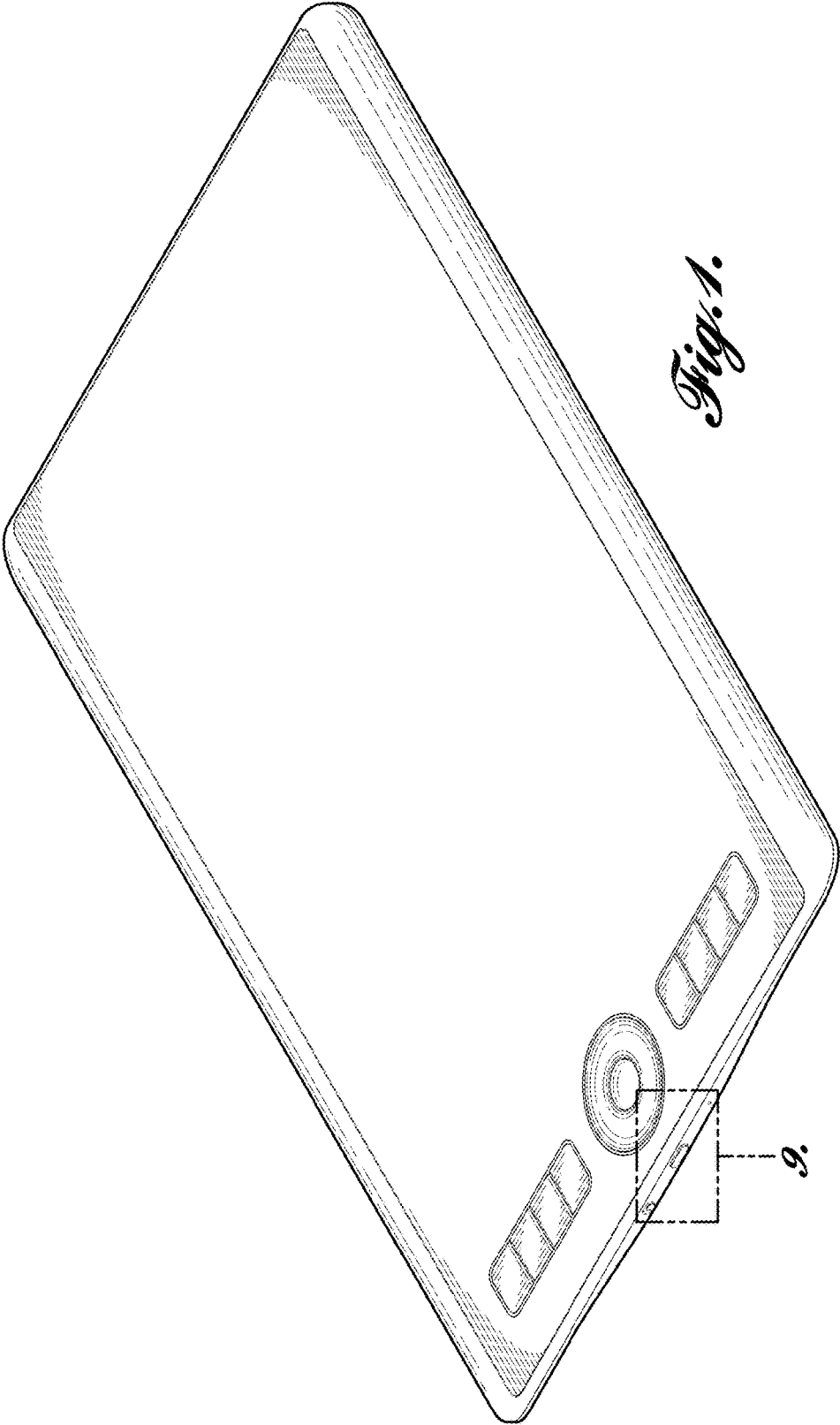
## FOREIGN PATENT DOCUMENTS

CN 303854589 S 9/2016  
 EM 001435259-0002 S 6/2015  
 JP D1372733 S 11/2009

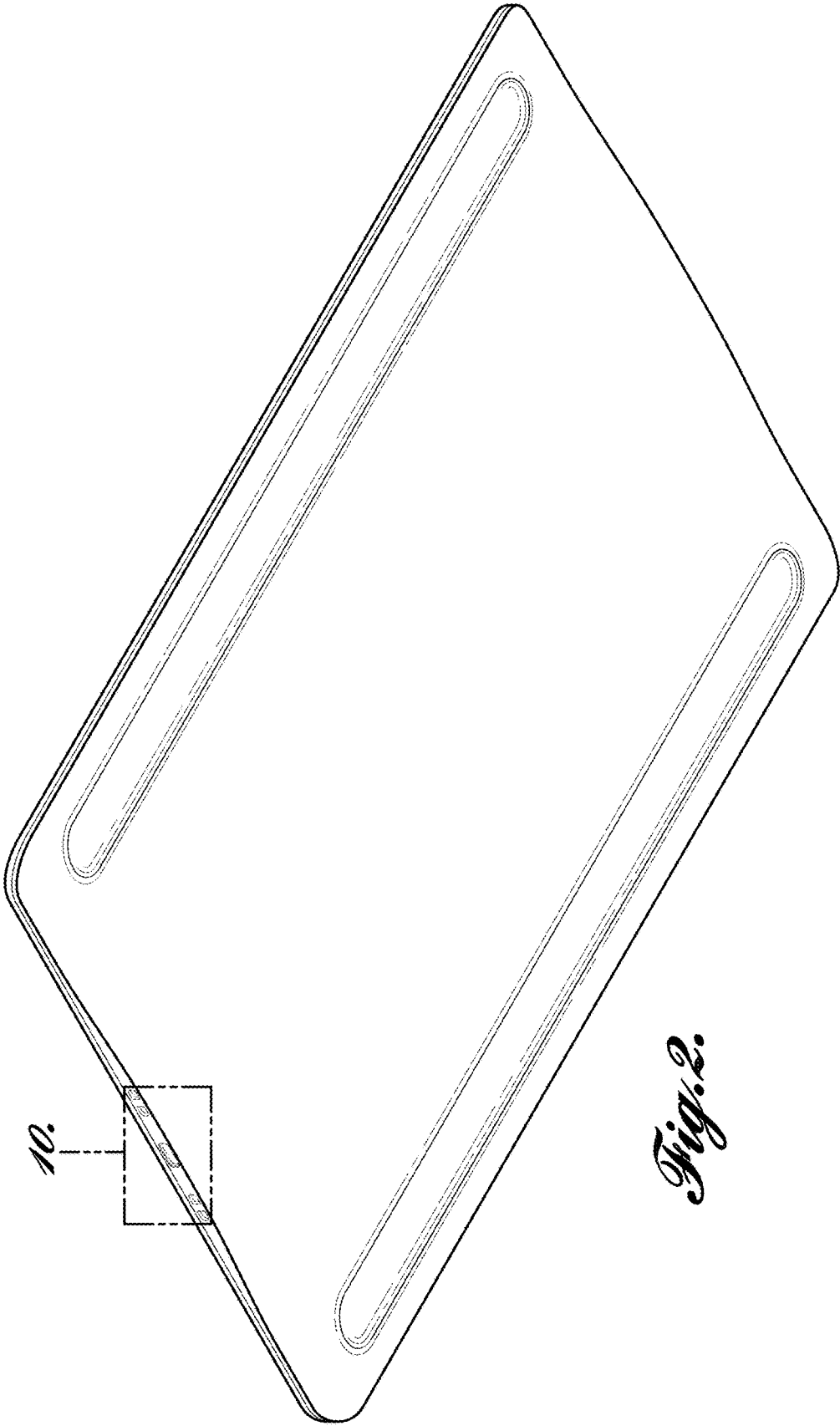
## OTHER PUBLICATIONS

“Intuos®pro: Special Edition,” Intuos Pro Special Edition Digital Pen Tablet, Wacom, <<http://www.wacom.com/en-us/products/pen-tablets/intuos-pro-se>> [retrieved Apr. 3, 2017], 13 pages.  
 EasyPen M506, Genius, [retrieved Jun. 21, 2017], 4 pages.  
 Flanwang drawing tablet, Jul. 9, 2015 [retrieved Jun. 20, 2017], 5 pages.

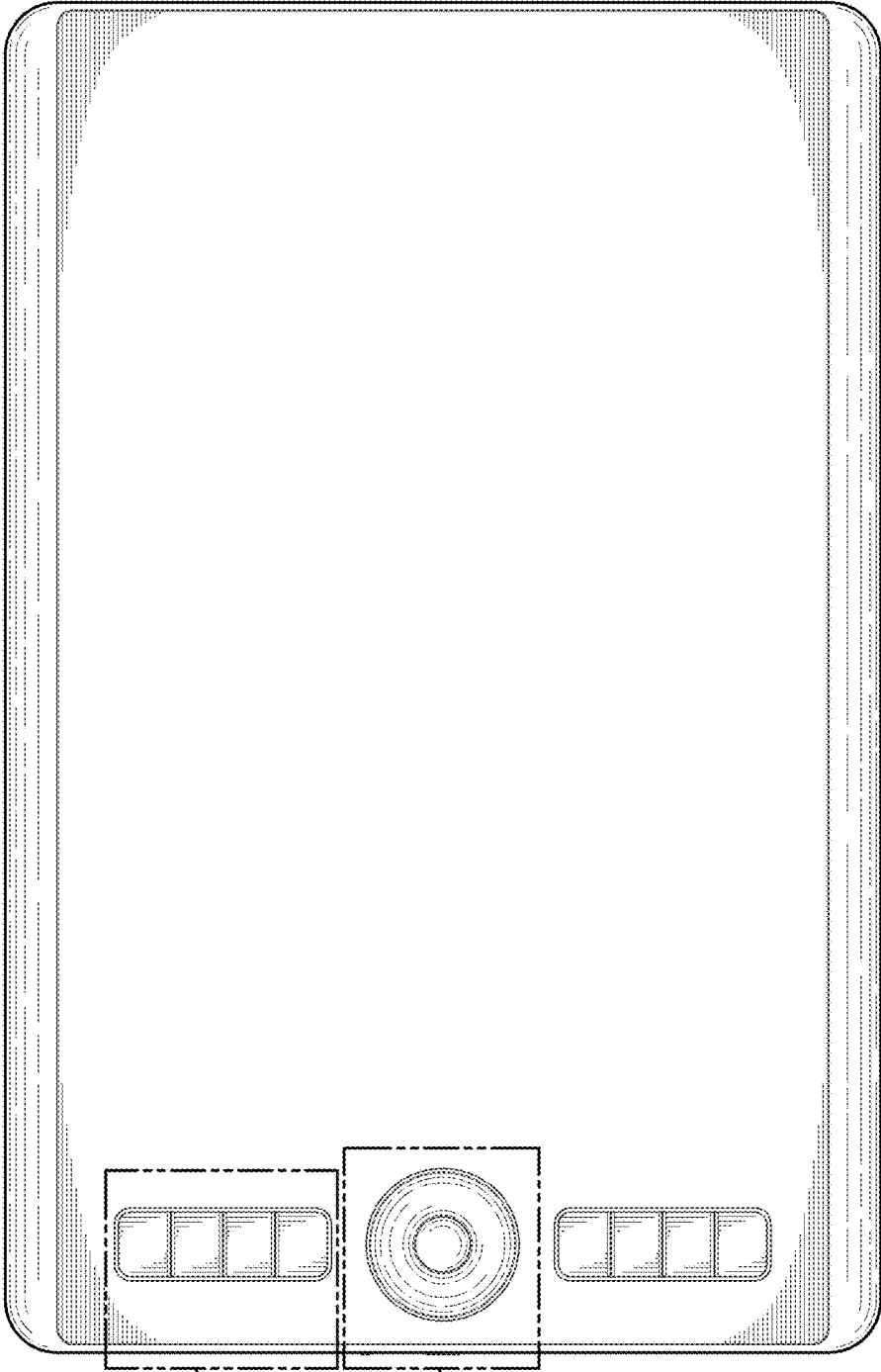
\* cited by examiner



*Fig. 1.*



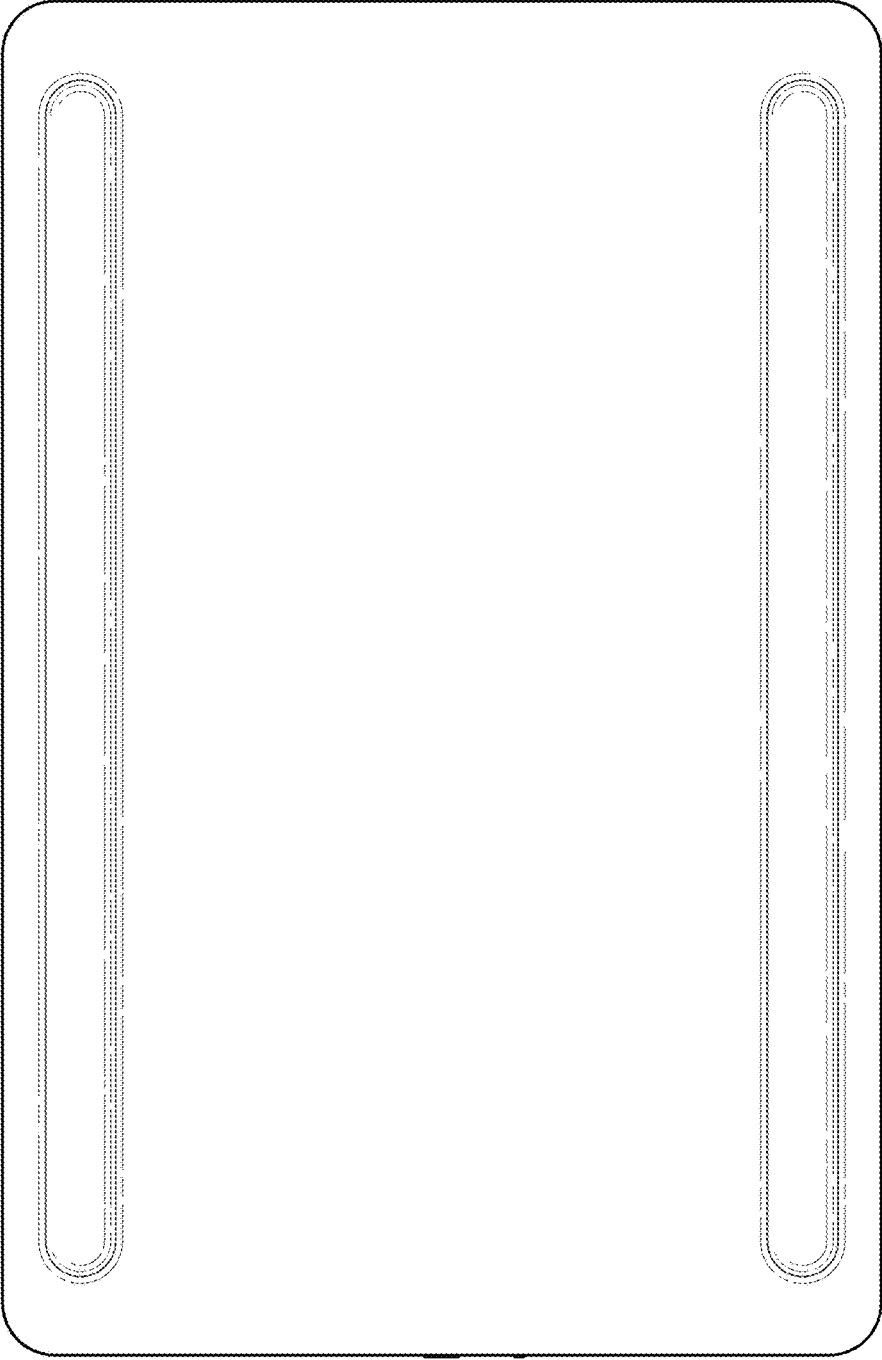
*Fig. 2.*



*Fig. 3.*

11.

12.



*Fig. 4.*



*Fig. 5.*



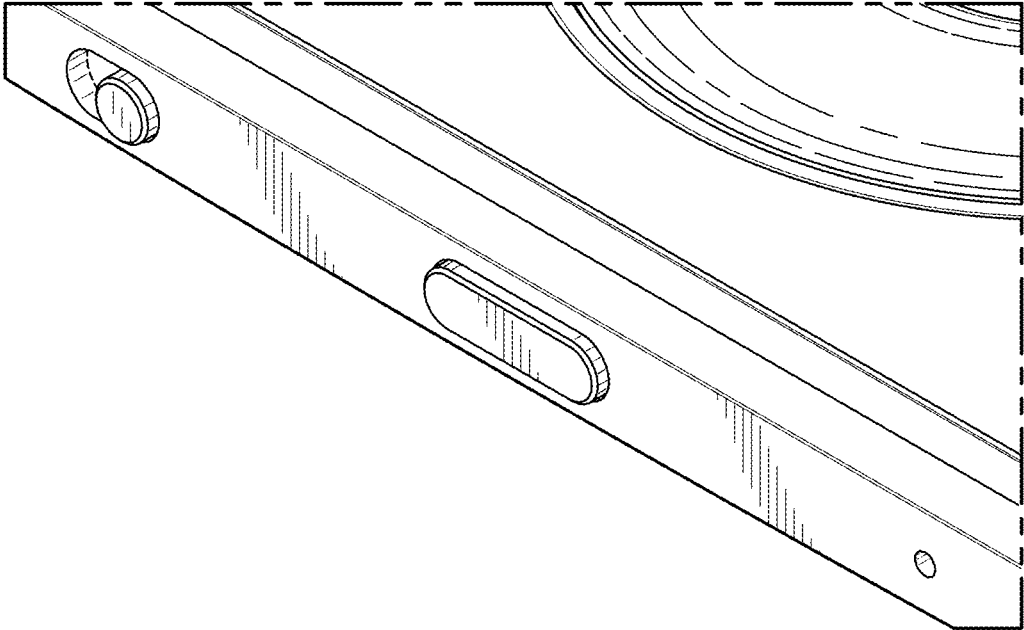
*Fig. 6.*



*Fig. 7.*

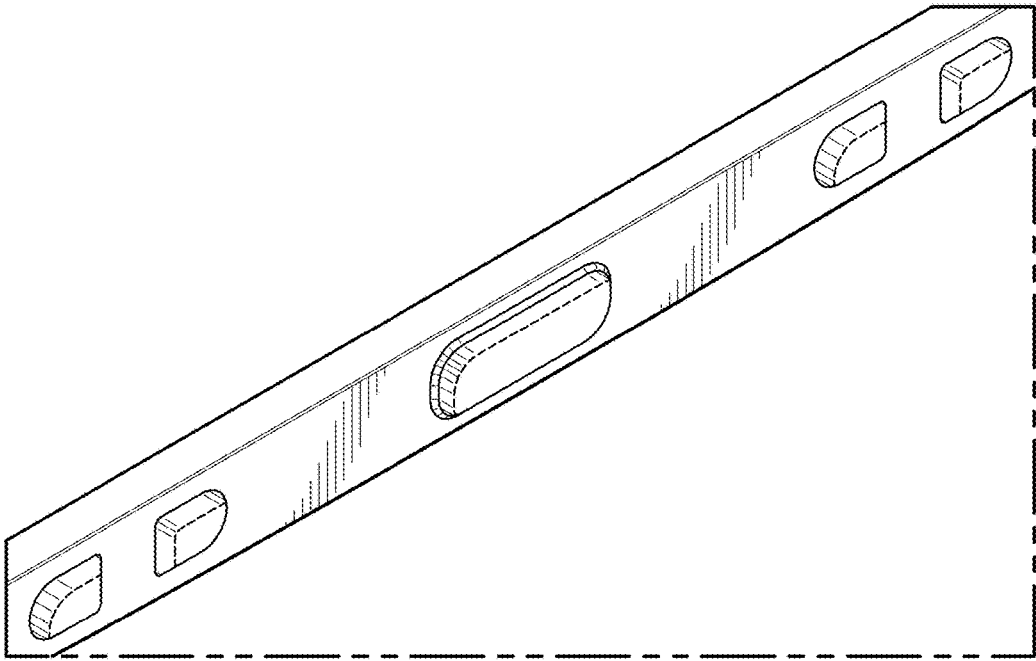


*Fig. 8.*

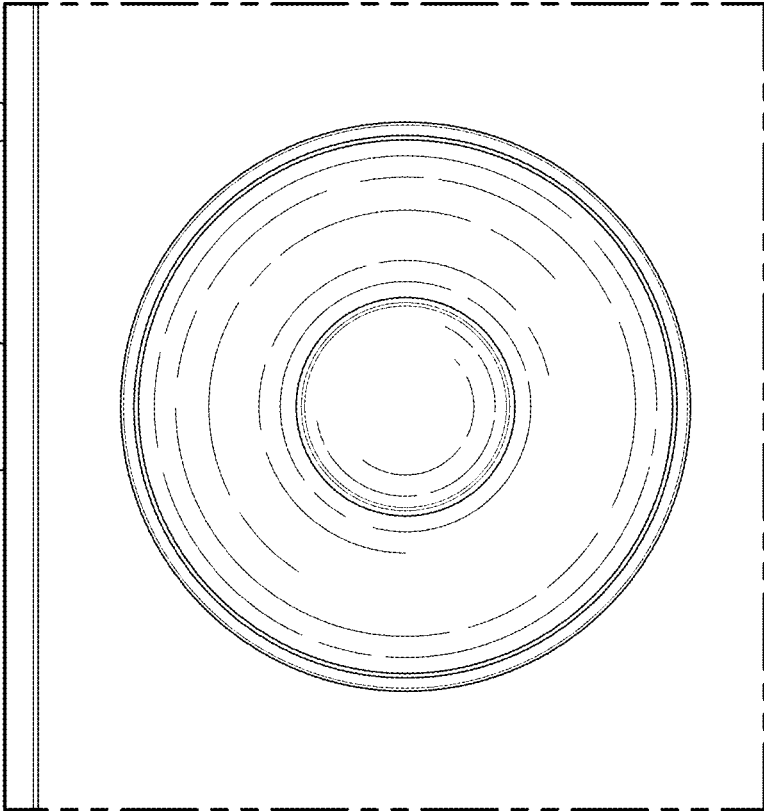


*Fig. 9.*

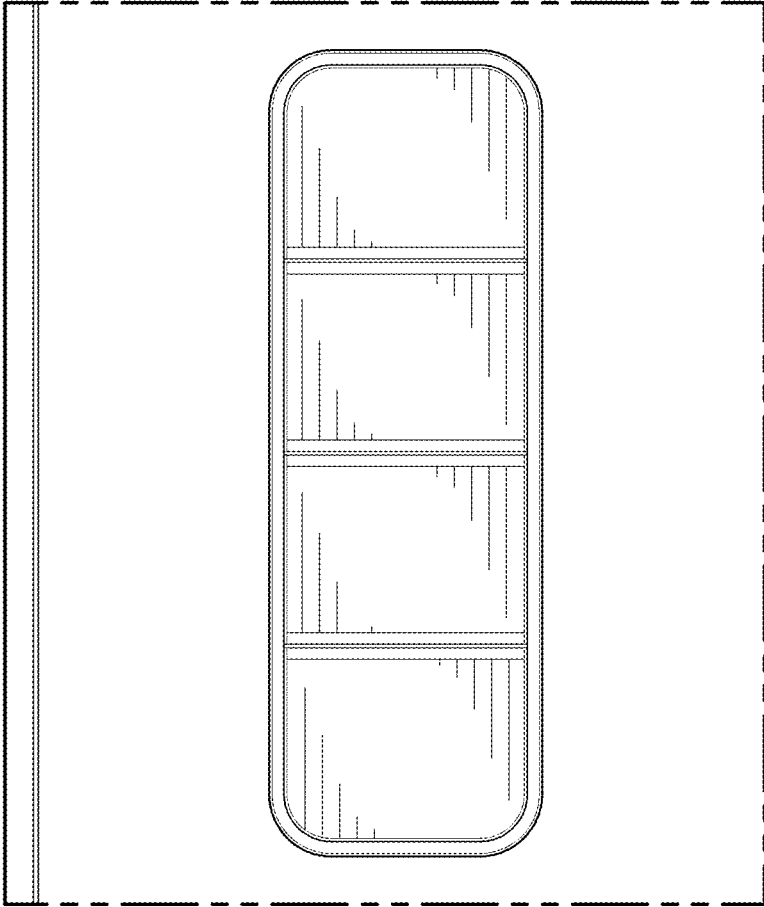




*Fig. 10.*



*Fig. 11.*



*Fig. 12.*