

(19) World Intellectual Property Organization
International Bureau



(43) International Publication Date
1 April 2010 (01.04.2010)

PCT

(10) International Publication Number
WO 2010/037038 A2

(51) International Patent Classification:

A61B 17/88 (2006.01) A61B 17/68 (2006.01)
A61B 17/90 (2006.01) A61B 17/56 (2006.01)

(21) International Application Number:

PCT/US2009/058632

(22) International Filing Date:

28 September 2009 (28.09.2009)

(25) Filing Language:

English

(26) Publication Language:

English

(30) Priority Data:

61/100,635	26 September 2008 (26.09.2008)	US
61/100,652	26 September 2008 (26.09.2008)	US
61/117,901	25 November 2008 (25.11.2008)	US
61/122,563	15 December 2008 (15.12.2008)	US
61/138,920	18 December 2008 (18.12.2008)	US

(71) Applicant (for all designated States except US): **SONOMA ORTHOPEDIC PRODUCTS, INC.** [US/US]; 650 Larkfield Shopping Center, Suite C, Santa Rosa, CA 95403 (US).

(72) Inventors; and

(75) Inventors/Applicants (for US only): **SARAVIA, Heber** [US/US]; 650 Larkfield Shopping Center, Suite C, Santa Rosa, CA 95403 (US). **MCDANIEL, Stephen, R.** [US/US]; 650 Larkfield Shopping Center, Suite C, Santa Rosa, CA 95403 (US). **PHAM, Trung, Ho** [US/US]; 650 Larkfield Shopping Center, Suite C, Santa Rosa, CA 95403 (US). **NELSON, Charles, L.** [US/US]; 650 Larkfield Shopping Center, Suite C, Santa Rosa, CA 95403

(US). **GUNTHER, Stephen** [US/US]; 650 Larkfield Shopping Center, Suite C, Santa Rosa, CA 95403 (US).

(74) Agents: **SHIMMICK, John, K.** et al.; Townsend and Townsend and Crew LLP, Two Embarcadero Center, 8th Floor, San Francisco, CA 94111 (US).

(81) Designated States (unless otherwise indicated, for every kind of national protection available): AE, AG, AL, AM, AO, AT, AU, AZ, BA, BB, BG, BH, BR, BW, BY, BZ, CA, CH, CL, CN, CO, CR, CU, CZ, DE, DK, DM, DO, DZ, EC, EE, EG, ES, FI, GB, GD, GE, GH, GM, GT, HN, HR, HU, ID, IL, IN, IS, JP, KE, KG, KM, KN, KP, KR, KZ, LA, LC, LK, LR, LS, LT, LU, LY, MA, MD, ME, MG, MK, MN, MW, MX, MY, MZ, NA, NG, NI, NO, NZ, OM, PE, PG, PH, PL, PT, RO, RS, RU, SC, SD, SE, SG, SK, SL, SM, ST, SV, SY, TJ, TM, TN, TR, TT, TZ, UA, UG, US, UZ, VC, VN, ZA, ZM, ZW.

(84) Designated States (unless otherwise indicated, for every kind of regional protection available): ARIPO (BW, GH, GM, KE, LS, MW, MZ, NA, SD, SL, SZ, TZ, UG, ZM, ZW), Eurasian (AM, AZ, BY, KG, KZ, MD, RU, TJ, TM), European (AT, BE, BG, CH, CY, CZ, DE, DK, EE, ES, FI, FR, GB, GR, HR, HU, IE, IS, IT, LT, LU, LV, MC, MK, MT, NL, NO, PL, PT, RO, SE, SI, SK, SM, TR), OAPI (BF, BJ, CF, CG, CI, CM, GA, GN, GQ, GW, ML, MR, NE, SN, TD, TG).

Published:

— without international search report and to be republished upon receipt of that report (Rule 48.2(g))

(54) Title: BONE FIXATION DEVICE, TOOLS AND METHODS

(57) Abstract: A bone fixation device is provided with an elongate body having a longitudinal axis and having a first state in which at least a portion of the body is flexible and a second state in which the body is generally rigid, an actuateable gripper disposed at one or more locations on the elongated body, a hub located on a proximal end of the elongated body, and an actuator operably connected to the gripper(s) to deploy the gripper(s) from a retracted configuration to an expanded configuration. Methods of repairing a fracture of a bone are also disclosed. One such method comprises inserting a bone fixation device into an intramedullary space of the bone to place at least a portion of an elongate body of the fixation device in a flexible state on one side of the fracture and at least a portion of a hub on another side of the fracture, and operating an actuator to deploy at least one gripper of the fixation device to engage an inner surface of the intramedullary space to anchor the fixation device to the bone. Alternative gripper designs are disclosed that may be used in various combinations.



WO 2010/037038 A2

BONE FIXATION DEVICE, TOOLS AND METHODS**CROSS-REFERENCE TO RELATED APPLICATIONS**

- 5 [0001] This application is a Continuation-in-Part of U.S. Application No. 11/383,269, titled
“MINIMALLY INVASIVE ACTUABLE BONE FIXATION DEVICES”, filed May 15, 2006
which claims priority to U.S. Provisional Application No. 60/682,652, titled “METHOD AND
SYSTEM FOR PROVIDING REINFORCEMENT OF BONES”, filed May 18, 2005. This
application is also a Continuation-in-part of U.S. Application No. 11/383,800 filed May 17,
10 2006, titled “DEPLOYABLE INTRAMEDULLARY STENT SYSTEM FOR
REINFORCEMENT OF BONE” which claims priority to U.S. Provisional Application No.
60/682,652, titled “METHOD AND SYSTEM FOR PROVIDING REINFORCEMENT OF
BONES”, filed May 18, 2005. This application is also a Continuation-in-Part of U.S.
Application No. 11/944,366, titled “FRACTURE FIXATION DEVICE, TOOLS AND
15 METHODS”, filed November 21, 2007 which claims priority to U.S. provisional applications:
No. 60/867,011, titled “BONE REPAIR IMPLANT WITH CENTRAL RATCHETING
GUIDEWIRE”, filed November 22, 2006; No. 60/866,976, titled “SURGICAL TOOLS FOR
USE IN DEPLOYING BONE REPAIR DEVICES,” filed November 22, 2006; and No.
60/949,071, titled “FRACTURE FIXATION DEVICE, TOOLS AND METHODS”, filed July
20 11, 2007. This application is also a Continuation-in-part of U.S. Application No. 12/482,388
titled “FRACTURE FIXATION DEVICE, TOOLS AND METHODS” filed June 10, 2009;
Application No. 12/482,395 titled “FRACTURE FIXATION DEVICE, TOOLS AND
METHODS” filed June 10, 2009 and Application No. 12/482,406 titled “FRACTURE
FIXATION DEVICE, TOOLS AND METHODS” filed June 10, 2009.
- 25 [0002] This application claims priority of U.S. Provisional Application No. 61/100,635,
titled “FRACTURE FIXATION DEVICE, TOOLS AND METHODS” filed September 26,
2008; U.S. Provisional Application No. 61/100,652, titled “FRACTURE FIXATION DEVICE,
TOOLS AND METHODS” filed September 26, 2008; U.S. Provisional Application No.
61/122,563, titled “BONE FIXATION DEVICE, TOOLS AND METHODS” filed December
30 15, 2008; U.S. Provisional Application No. 61/138,920, titled “BONE FIXATION DEVICE,
TOOLS AND METHODS” filed December 18, 2008; and U.S. Provisional Application No.
61/117,901, titled “BONE FRACTURE FIXATION SCREWS, SYSTEMS AND METHODS
OF USE” filed November 25, 2008.

INCORPORATION BY REFERENCE

[0003] All publications and patent applications mentioned in this specification are herein incorporated by reference to the same extent as if each individual publication or patent application was specifically and individually indicated to be incorporated by reference

5

BACKGROUND OF THE INVENTION

[0004] The present invention relates to devices, tools and methods for providing reinforcement of bones. More specifically, the present invention relates to devices, tools and methods for providing reconstruction and reinforcement of bones, including diseased, osteoporotic and fractured bones.

10

[0005] Bone fractures are a common medical condition both in the young and old segments of the population. However, with an increasingly aging population, osteoporosis has become more of a significant medical concern in part due to the risk of osteoporotic fractures.

15

Osteoporosis and osteoarthritis are among the most common conditions to affect the musculoskeletal system, as well as frequent causes of locomotor pain and disability.

Osteoporosis can occur in both human and animal subjects (*e.g.* horses). Osteoporosis (OP) and osteoarthritis (OA) occur in a substantial portion of the human population over the age of fifty.

20

The National Osteoporosis Foundation estimates that as many as 44 million Americans are affected by osteoporosis and low bone mass, leading to fractures in more than 300,000 people over the age of 65. In 1997 the estimated cost for osteoporosis related fractures was \$13 billion. That figure increased to \$17 billion in 2002 and is projected to increase to \$210-240 billion by 2040. Currently it is expected that one in two women, and one in four men, over the age of 50 will suffer an osteoporosis-related fracture. Osteoporosis is the most important underlying cause of fracture in the elderly. Also, sports and work-related accidents account for a significant number of bone fractures seen in emergency rooms among all age groups.

25

[0006] One current treatment of bone fractures includes surgically resetting the fractured bone. After the surgical procedure, the fractured area of the body (*i. e.*, where the fractured bone is located) is often placed in an external cast for an extended period of time to ensure that the fractured bone heals properly. This can take several months for the bone to heal and for the patient to remove the cast before resuming normal activities.

30

[0007] In some instances, an intramedullary (IM) rod or nail is used to align and stabilize the fracture. In that instance, a metal rod is placed inside a canal of a bone and fixed in place, typically at both ends. See, for example, Fixion™ IM(Nail), www.disc-o-tech.com. This approach requires incision, access to the canal, and placement of the IM nail. The nail can be subsequently removed or left in place. A conventional IM nail procedure requires a similar, but

35

possibly larger, opening to the space, a long metallic nail being placed across the fracture, and either subsequent removal, and or when the nail is not removed, a long term implant of the IM nail. The outer diameter of the IM nail must be selected for the minimum inside diameter of the space. Therefore, portions of the IM nail may not be in contact with the canal. Further, micro-
5 motion between the bone and the IM nail may cause pain or necrosis of the bone. In still other cases, infection can occur. The IM nail may be removed after the fracture has healed. This requires a subsequent surgery with all of the complications and risks of a later intrusive procedure. In general, rigid IM rods or nails are difficult to insert, can damage the bone and require additional incisions for cross-screws to attach the rods or nails to the bone.

10 [0008] Some IM nails are inflatable. See, for example, Meta-Fix IM Nailing System, www.disc-o-tech.com. Such IM nails require inflating the rod with very high pressures, endangering the surrounding bone. Inflatable nails have many of the same drawbacks as the rigid IM nails described above.

15 [0009] External fixation is another technique employed to repair fractures. In this approach, a rod may traverse the fracture site outside of the epidermis. The rod is attached to the bone with trans-dermal screws. If external fixation is used, the patient will have multiple incisions, screws, and trans-dermal infection paths. Furthermore, the external fixation is cosmetically intrusive, bulky, and prone to painful inadvertent manipulation by environmental conditions such as, for example, bumping into objects and laying on the device.

20 [00010] Other concepts relating to bone repair are disclosed in, for example, US Patents 5,108,404 to Scholten for Surgical Protocol for Fixation of Bone Using Inflatable Device; 4,453,539 to Raftopoulos et al. for Expandable Intramedullary Nail for the Fixation of Bone Fractures; 4,854,312 to Raftopolous for Expanding Nail; 4,932,969 to Frey et al. for Joint Endoprosthesis; 5,571,189 to Kuslich for Expandable Fabric Implant for Stabilizing the Spinal
25 Motion Segment; 4,522,200 to Stednitz for Adjustable Rod; 4,204,531 to Aginsky for Nail with Expanding Mechanism; 5,480,400 to Berger for Method and Device for Internal Fixation of Bone Fractures; 5,102,413 to Poddar for Inflatable Bone Fixation Device; 5,303,718 to Krajicek for Method and Device for the Osteosynthesis of Bones; 6,358,283 to Hogfors et al. for Implantable Device for Lengthening and Correcting Malpositions of Skeletal Bones; 6,127,597 to Beyar et al.
30 for Systems for Percutaneous Bone and Spinal Stabilization, Fixation and Repair; 6,527,775 to Warburton for Interlocking Fixation Device for the Distal Radius; U.S. Patent Publication US2006/0084998 A1 to Levy et al. for Expandable Orthopedic Device; and PCT Publication WO 2005/112804 A1 to Myers Surgical Solutions, LLC for Fracture Fixation and Site Stabilization System. Other fracture fixation devices, and tools for deploying fracture fixation

devices, have been described in: US Patent Appl. Publ. No. 2006/0254950; USSN 60/867,011 (filed 11/22/06); USSN 60/866,976 (filed 11/22/06); and USSN 60/866,920 (filed 11/22/06).

[00011] In view of the foregoing, it would be desirable to have a device, system and method for providing effective and minimally invasive bone reinforcement and fracture fixation to treat fractured or diseased bones, while improving the ease of insertion, eliminating cross-screw incisions and minimizing trauma.

SUMMARY OF THE INVENTION

[00012] Aspects of the invention relate to embodiments of a bone fixation device and to methods for using such a device for repairing a bone fracture. The bone fixation device may include an elongate body with a longitudinal axis and having a flexible state and a rigid state. The device further may include a plurality of grippers disposed at longitudinally-spaced locations along the elongated body, a rigid hub connected to the elongated body, and an actuator that is operably-connected to the grippers to deploy the grippers from a first shape to an expanded second shape.

[00013] In one embodiment, a bone fixation device is provided with an elongate body having a longitudinal axis and having a first state in which at least a portion of the body is flexible and a second state in which the body is generally rigid, an actuatable gripper disposed at a distal location on the elongated body, a hub located on a proximal end of the elongated body, and an actuator operably connected to the gripper to deploy the gripper from a retracted configuration to an expanded configuration.

[00014] Methods of repairing a fracture of a bone are also disclosed. One such method comprises inserting a bone fixation device into an intramedullary space of the bone to place at least a portion of an elongate body of the fixation device in a flexible state on one side of the fracture and at least a portion of a hub on another side of the fracture, and operating an actuator to deploy at least one gripper of the fixation device to engage an inner surface of the intramedullary space to anchor the fixation device to the bone.

[00015] One embodiment of the present invention provides a low weight to volume mechanical support for fixation, reinforcement and reconstruction of bone or other regions of the musculo-skeletal system in both humans and animals. The method of delivery of the device is another aspect of the invention. The method of delivery of the device in accordance with the various embodiments of the invention reduces the trauma created during surgery, decreasing the risks associated with infection and thereby decreasing the recuperation time of the patient. The framework may in one embodiment include an expandable and contractible structure to permit re-placement and removal of the reinforcement structure or framework.

[00016] In accordance with the various embodiments of the present invention, the mechanical supporting framework or device may be made from a variety of materials such as metal, composite, plastic or amorphous materials, which include, but are not limited to, steel, stainless steel, cobalt chromium plated steel, titanium, nickel titanium alloy (nitinol), superelastic alloy, and polymethylmethacrylate (PMMA). The device may also include other polymeric materials that are biocompatible and provide mechanical strength, that include polymeric material with ability to carry and delivery therapeutic agents, that include bioabsorbable properties, as well as composite materials and composite materials of titanium and polyetheretherketone (PEEK™), composite materials of polymers and minerals, composite materials of polymers and glass fibers, composite materials of metal, polymer, and minerals.

[00017] Within the scope of the present invention, each of the aforementioned types of device may further be coated with proteins from synthetic or animal source, or include collagen coated structures, and radioactive or brachytherapy materials. Furthermore, the construction of the supporting framework or device may include radio-opaque markers or components that assist in their location during and after placement in the bone or other region of the musculo-skeletal systems.

[00018] Further, the reinforcement device may, in one embodiment, be osteo incorporating, such that the reinforcement device may be integrated into the bone.

[00019] In still another embodiment of the invention, a method of repairing a bone fracture is disclosed that comprises: accessing a fracture along a length of a bone through a bony protuberance at an access point at an end of a bone; advancing a bone fixation device into a space through the access point at the end of the bone; bending a portion of the bone fixation device along its length to traverse the fracture; and locking the bone fixation device into place within the space of the bone. The method can also include the step of advancing an obturator through the bony protuberance and across the fracture prior to advancing the bone fixation device into the space. In yet another embodiment of the method, the step of anchoring the bone fixation device within the space can be included.

[00020] An aspect of the invention discloses a removable bone fixation device that uses a single port of insertion and has a single-end of remote actuation wherein a bone fixation device stabilizes bone after it has traversed the fracture. The bone fixation device is adapted to provide a single end in one area or location where the device initiates interaction with bone. The device can be deployed such that the device interacts with bone. Single portal insertion and single-end remote actuation enables the surgeon to insert and deploy the device, deactivate and remove the device, reduce bone fractures, displace or compress the bone, and lock the device in place. In addition, the single-end actuation enables the device to grip bone, compresses the rigidizable

flexible body, permits axial, torsional and angular adjustments to its position during surgery, and releases the device from the bone during its removal procedure. A removable extractor can be provided in some embodiments of the device to enable the device to be placed and extracted by deployment and remote actuation from a single end. The device of the invention can be adapted and configured to provide at least one rigidizable flexible body or sleeve. Further the body can be configured to be flexible in all angles and directions. The flexibility provided is in selective planes and angles in the Cartesian, polar, or cylindrical coordinate systems. Further, in some embodiments, the body is configured to have a remote actuation at a single end. Additionally, the body can be configured to have apertures, windings, etc. The device may be configured to function with non-flexible bodies for use in bones that have a substantially straight segment or curved segments with a constant radius of curvature. Another aspect of the invention includes a bone fixation device in that has mechanical geometry that interacts with bone by a change in the size of at least one dimension of a Cartesian, polar, or spherical coordinate system. Further, in some embodiments, bioabsorbable materials can be used in conjunction with the devices, for example by providing specific subcomponents of the device configured from bioabsorbable materials. A sleeve can be provided in some embodiments where the sleeve is removable, has deployment, remote actuation, and a single end. Where a sleeve is employed, the sleeve can be adapted to provide a deployable interdigitation process or to provide an aperture along its length through which the deployable interdigitation process is adapted to engage bone. In some embodiments, the deployable interdigitation process is further adapted to engage bone when actuated by the sleeve. In some embodiments, the bone fixation device further comprises a cantilever adapted to retain the deployable bone fixation device within the space. The sleeve can further be adapted to be expanded and collapsed within the space by a user. One end of the device can be configured to provide a blunt obturator surface adapted to advance into the bone. A guiding tip may also be provided that facilitates guiding the device through the bone. Further, the deployable bone fixation device can be adapted to receive external stimulation to provide therapy to the bone. The device can further be adapted to provide an integral stimulator which provides therapy to the bone. In still other embodiments, the device can be adapted to receive deliver therapeutic stimulation to the bone.

[00021] The devices disclosed herein may be employed in various regions of the body, including: cranial, thoracic, lower extremities and upper extremities. Additionally, the devices are suitable for a variety of breaks including, metaphyseal and diaphyseal.

[00022] The fracture fixation devices of various embodiments of the invention are adapted to be inserted through an opening of a fractured bone, such as the radius (*e.g.*, through a bony protuberance on a distal or proximal end or through the midshaft) into the intramedullary canal

of the bone. In some embodiments, the fixation device has two main components, one configured component for being disposed on the side of the fracture closest to the opening and one component configured for being disposed on the other side of the fracture from the opening so that the fixation device traverses the fracture.

5 [00023] The device components cooperate to align, fix and/or reduce the fracture so as to promote healing. The device may be removed from the bone after insertion (*e.g.*, after the fracture has healed or for other reasons), or it may be left in the bone for an extended period of time or permanently.

10 [00024] In some embodiments, the fracture fixation device has one or more actuatable anchors or grippers on its proximal and/or distal ends. These anchors may be used to hold the fixation device to the bone while the bone heals.

15 [00025] In some embodiments, to aid in insertion into the intramedullary canal, at least one component of the fracture fixation device has a substantially flexible state and a substantially rigid state. Once in place, deployment of the device also causes the components to change from the flexible state to a rigid state to aid in proper fixation of the fracture. At least one of the components may be substantially rigid or semi-flexible. At least one component may provide a bone screw attachment site for the fixation device.

20 [00026] Embodiments of the invention also provide deployment tools with a tool guide for precise alignment of one or more bone screws with the fracture fixation device. These embodiments also provide bone screw orientation flexibility so that the clinician can select an orientation for the bone screw(s) that will engage the fixation device as well as any desired bone fragments or other bone or tissue locations.

25 [00027] These and other features and advantages of the present invention will be understood upon consideration of the following detailed description of the invention and the accompanying drawings.

BRIEF DESCRIPTION OF THE DRAWINGS

30 [00028] The novel features of the invention are set forth with particularity in the appended claims. A better understanding of the features and advantages of the present invention will be obtained by reference to the following detailed description that sets forth illustrative embodiments, in which the principles of the invention are utilized, and the accompanying drawings of which:

[00029] Figure 1 is a perspective view of an embodiment of a bone fixation device implanted in a bone according to the invention.

35 [00030] Figure 2 is another perspective view of the implanted device of Figure 1.

[00031] Figure 3 is a longitudinal cross-section view of the bone fixation device of Figure 1 in a non-deployed state.

[00032] Figure 4 is a plan view of a combination deployment tool that may be used with the bone fixation device of Figure 1.

5 [00033] Figure 5 is a cross-section view of the tool and device shown in Figure 4.

[00034] Figure 6 is a perspective view of the tool and device shown in Figure 4..

[00035] Figure 7 is a cross-section view of the implanted device of Figure 1.

[00036] Figure 8 is a plan view of an alternative combination deployment tool that may be used with the bone fixation device of Figure 1.

10 [00037] Figure 9A is a perspective view of an alternative embodiment of the implanted device of Figure 1.

[00038] Figure 9B is a perspective view of another alternative embodiment of the implanted device of Figure 1.

[00039] Figure 10A is a perspective view of another embodiment of a bone fixation device shown deployed in a fractured clavicle.

[00040] Figure 10B is perspective view of the device shown in Figure 10A shown in a deployed state.

[00041] Figure 10C is a side elevation view of the device shown in Figure 10A shown in a retracted or undeployed state.

20 [00042] Figure 10D is a side elevation view of the device shown in Figure 10A shown in a deployed state.

[00043] Figure 10E is a cross-sectional view of the device shown in Figure 10A shown in a retracted or undeployed state.

[00044] Figure 10F is a cross-sectional view of the device shown in Figure 10A shown in a deployed state.

[00045] Figure 10G is a perspective view of a gripper of the device shown in Figure 10A shown in a retracted or undeployed state.

[00046] Figure 10H is a side elevation view of a gripper and actuator of the device shown in Figure 10A shown in a retracted or undeployed state.

30 [00047] Figure 10I is a perspective view of a gripper and actuator of the device shown in Figure 10A shown in a deployed state.

[00048] Figure 11A is perspective view of another embodiment of a bone fixation device shown in a retracted or undeployed state.

[00049] Figure 11B is perspective view of the device shown in Figure 11A shown in a deployed state.

[00050] Figure 11C is a cross-sectional view of the device shown in Figure 11A shown in a retracted or undeployed state.

[00051] Figure 11D is a cross-sectional view of the device shown in Figure 11A shown in a deployed state.

5 [00052] Figure 12A is a perspective view showing an alternative gripper design in a retracted or undeployed state.

[00053] Figure 12B is a perspective view showing the gripper of Figure 12A in a deployed state.

10 [00054] Figure 12C is a side elevation view showing the gripper of Figure 12A in a retracted or undeployed state.

[00055] Figure 12D is a side elevation view showing the gripper of Figure 12A in a deployed state.

[00056] Figure 12E is a proximally-looking end view (with an end piece removed for clarity) showing the gripper of Figure 12A in a retracted or undeployed state.

15 [00057] Figure 12F is a proximally-looking end view (with an end piece removed for clarity) showing the gripper of Figure 12A in a deployed state.

[00058] Figure 12G is an exploded perspective view showing the gripper of Figure 12A.

[00059] Figure 13A is a perspective view showing another alternative gripper design in a retracted or undeployed state.

20 [00060] Figure 13B is a perspective view showing the gripper of Figure 13A in a deployed state.

[00061] Figure 13C is a side elevation view showing the gripper of Figure 13A in a retracted or undeployed state.

25 [00062] Figure 13D is a side elevation view showing the gripper of Figure 13A in a deployed state.

[00063] Figure 13E is an end view showing an end component of the gripper of Figure 13A.

[00064] Figure 13F is an end view (with an end component removed for clarity) showing the gripper of Figure 13A in a retracted or undeployed state.

30 [00065] Figure 13G is an end view (with an end component removed for clarity) showing the gripper of Figure 13A in a deployed state.

[00066] Figure 13H is an exploded perspective view showing the gripper of Figure 13A.

[00067] Figure 14A is a perspective view showing another alternative gripper design in a retracted or undeployed state.

35 [00068] Figure 14B is a perspective view showing the gripper of Figure 14A in a deployed state.

[00069] Figure 14C is a side elevation view showing the gripper of Figure 14A in a retracted or undeployed state.

[00070] Figure 14D is a side elevation view showing the gripper of Figure 14A in a deployed state.

5 [00071] Figure 14E is an end view showing the gripper of Figure 14A in a retracted or undeployed state.

[00072] Figure 14F is an end view showing the gripper of Figure 14A in a deployed state.

[00073] Figure 14G is an end view showing an end component of the gripper of Figure 14A.

10 [00074] Figure 14H is an exploded perspective view showing the gripper of Figure 14A with only one set of gripper arms shown for clarity.

[00075] Figure 15A is a perspective view showing another alternative gripper design in a retracted or undeployed state.

[00076] Figure 15B is a perspective view showing the gripper of Figure 15A in a deployed state.

15 [00077] Figure 15C is a side elevation view showing the gripper of Figure 15A in a retracted or undeployed state.

[00078] Figure 15D is a side elevation view showing the gripper of Figure 15A in a deployed state.

20 [00079] Figure 15E is an end view showing the gripper of Figure 15A in a retracted or undeployed state.

[00080] Figure 15F is an end view showing the gripper of Figure 15A in a deployed state.

[00081] Figure 15G is an exploded perspective view showing an end component of the gripper of Figure 15A with arm-mounting pins.

25 [00082] Figure 15H is an exploded perspective view showing the gripper of Figure 15A with two of the three sets of gripper arms removed for clarity.

[00083] Figure 16A is a perspective view showing another alternative gripper design in a retracted or undeployed state.

[00084] Figure 16B is a side elevational view showing the gripper of Figure 16A in a retracted or undeployed state.

30 [00085] Figure 16C is a perspective view showing the gripper of Figure 16A in a deployed state.

[00086] Figure 16D is an end view showing the gripper of Figure 16A in a deployed state.

[00087] Figure 17A is a perspective view showing another alternative gripper design in a retracted or undeployed state.

[00088] Figure 17B is a side elevational view showing the gripper of Figure 17A in a retracted or undeployed state.

[00089] Figure 18A is a perspective view showing another alternative gripper design in a retracted or undeployed state.

5 [00090] Figure 18B is a side elevational view showing the gripper of Figure 18A in a retracted or undeployed state.

[00091] Figure 19A is a perspective view showing another alternative gripper design in a retracted or undeployed state.

10 [00092] Figure 19B is a side elevational view showing the gripper of Figure 19A in a retracted or undeployed state.

[00093] Figure 20A is a perspective view showing another alternative gripper design in a retracted or undeployed state.

[00094] Figure 20B is a side elevational view showing the gripper of Figure 20A in a retracted or undeployed state.

15 [00095] Figure 21A is a perspective view showing another alternative gripper design in a retracted or undeployed state.

[00096] Figure 21B is a side elevational view showing the gripper of Figure 21A in a retracted or undeployed state.

20 [00097] Figure 22A is a perspective view showing another bone fixation device in a retracted or undeployed state.

[00098] Figure 22B is a top plan view showing the device of Figure 22A in a retracted or undeployed state.

[00099] Figure 22C is a side elevational view showing the device of Figure 22A in a retracted or undeployed state.

25 [000100] Figure 22D is a perspective view showing the device of Figure 22A in a deployed state.

[000101] Figure 22E is a top plan view showing the device of Figure 22A in a deployed state.

[000102] Figure 22F is a side elevational view showing the device of Figure 22A in a deployed state.

30 [000103] Figure 23A is an enlarged perspective view showing just the distal gripper of the device of Figure 22A in a retracted or undeployed state.

[000104] Figure 23B is a side elevational view showing the gripper of Figure 23A in a retracted or undeployed state.

35 [000105] Figure 23C is a top plan view showing the gripper of Figure 23A in a retracted or undeployed state.

[000106] Figure 23D is a perspective view showing the gripper of Figure 23A in a deployed state.

[000107] Figure 23E is a side elevational view showing the gripper of Figure 23A in a deployed state.

5 [000108] Figure 23F is a top plan view showing the gripper of Figure 23A in a deployed state.

[000109] Figure 23G is an exploded perspective view showing the gripper of Figure 23A.

[000110] Figures 24-26 are various views showing another embodiment of a bone fixation device.

[000111] Figures 27-28 are views showing another embodiment of a bone fixation device.

10 [000112] Figure 29 is a perspective view showing the device of Figures 27-28 coupled with a screw hole forming guide tool.

[000113] Figures 30-31 are various views showing another embodiment of a bone fixation device.

[000114] Figures 32-35 are various views showing another embodiment of a bone fixation
15 device.

[000115] Figures 36-39 are various views showing another embodiment of a bone fixation device.

[000116] Figure 40 is a perspective view showing another embodiment of a flexible-to-rigid body portion of a bone fixation device.

20 [000117] Figure 41 is a plan view showing part of the cut pattern of the body portion of Figure 40 laid flat.

[000118] Figure 42 is a perspective view showing another embodiment of a flexible-to-rigid body portion of a bone fixation device.

[000119] Figure 43A is a plan view showing part of the cut pattern of the body portion of
25 Figure 42 laid flat.

[000120] Figure 43B is a plan view showing part of a cut pattern laid flat, similar to the one shown in Figures 42 and 43A.

[000121]

[000122] Figure 44 is a perspective view showing another embodiment of a flexible-to-rigid
30 body portion of a bone fixation device.

[000123] Figure 45 is a plan view showing part of the cut pattern of the body portion of Figure 44 laid flat.

[000124] Figure 46 is a perspective view showing another embodiment of a flexible-to-rigid body portion of a bone fixation device.

[000125] Figure 47 is a plan view showing part of the cut pattern of the body portion of Figure 46 laid flat.

[000126] Figure 48 is a perspective view showing another embodiment of a flexible-to-rigid body portion of a bone fixation device.

5 [000127] Figure 49 is a plan view showing the cut pattern of the body portion of Figure 48 laid flat.

DETAILED DESCRIPTION OF THE INVENTION

10 [000128] By way of background and to provide context for the invention, it may be useful to understand that bone is often described as a specialized connective tissue that serves three major functions anatomically. First, bone provides a mechanical function by providing structure and muscular attachment for movement. Second, bone provides a metabolic function by providing a reserve for calcium and phosphate. Finally, bone provides a protective function by enclosing
15 bone marrow and vital organs. Bones can be categorized as long bones (*e.g.* radius, femur, tibia and humerus) and flat bones (*e.g.* skull, scapula and mandible). Each bone type has a different embryological template. Further each bone type contains cortical and trabecular bone in varying proportions. The devices of this invention can be adapted for use in any of the bones of the body as will be appreciated by those skilled in the art.

20 [000129] Cortical bone (compact) forms the shaft, or diaphysis, of long bones and the outer shell of flat bones. The cortical bone provides the main mechanical and protective function. The trabecular bone (cancellous) is found at the end of the long bones, or the epiphysis, and inside the cortex of flat bones. The trabecular bone consists of a network of interconnecting trabecular plates and rods and is the major site of bone remodeling and resorption for mineral homeostasis.
25 During development, the zone of growth between the epiphysis and diaphysis is the metaphysis. Finally, woven bone, which lacks the organized structure of cortical or cancellous bone, is the first bone laid down during fracture repair. Once a bone is fractured, the bone segments are positioned in proximity to each other in a manner that enables woven bone to be laid down on the surface of the fracture. This description of anatomy and physiology is provided in order to
30 facilitate an understanding of the invention. Persons of skill in the art will also appreciate that the scope and nature of the invention is not limited by the anatomy discussion provided. Further, it will be appreciated there can be variations in anatomical characteristics of an individual patient, as a result of a variety of factors, which are not described herein. Further, it will be appreciated there can be variations in anatomical characteristics between bones which are not described
35 herein.

[000130] Figures 1 and 2 are perspective views of an embodiment of a bone fixation device 100 having a proximal end 102 (nearest the surgeon) and a distal end 104 (further from surgeon) and positioned within the bone space of a patient according to the invention. In this example, device 100 is shown implanted in the upper (or proximal) end of an ulna 106. The proximal end and distal end, as used in this context, refers to the position of an end of the device relative to the remainder of the device or the opposing end as it appears in the drawing. The proximal end can be used to refer to the end manipulated by the user or physician. The distal end can be used to refer to the end of the device that is inserted and advanced within the bone and is furthest away from the physician. As will be appreciated by those skilled in the art, the use of proximal and distal could change in another context, *e.g.* the anatomical context in which proximal and distal use the patient as reference, or where the entry point is distal from the surgeon.

[000131] When implanted within a patient, the device can be held in place with suitable fasteners such as wire, screws, nails, bolts, nuts and/or washers. The device 100 is used for fixation of fractures of the proximal or distal end of long bones such as intracapsular, intertrochanteric, intercervical, supracondylar, or condylar fractures of the femur; for fusion of a joint; or for surgical procedures that involve cutting a bone. The devices 100 may be implanted or attached through the skin so that a pulling force (traction may be applied to the skeletal system).

[000132] In the embodiment shown in Fig. 1, the design of the metaphyseal to diaphyseal fixation device 100 depicted is adapted to provide a bone engaging mechanism or gripper 108 adapted to engage target bone of a patient from the inside of the bone. As configured for this anatomical application, the device is designed to facilitate bone healing when placed in the intramedullary space within a post fractured bone. This device 100 has a gripper 108 positioned distally and shown deployed radially outward against the wall of the intramedullary cavity. On entry into the cavity, gripper 108 is flat and retracted (Figure 3). Upon deployment, gripper 108 pivots radially outward and grips the diaphyseal bone from the inside of the bone. One or more screws 110 placed through apertures through the hub 112 lock the device 100 to the metaphyseal bone. Hence, the metaphysis and the diaphysis are joined. A flexible-to-rigid body portion 114 may also be provided, and in this embodiment is positioned between gripper 108 and hub 112. It may be provided with wavy spiral cuts 116 for that purpose, as will be described in more detail below.

[000133] Figure 3 shows a longitudinal cross-section of device 100 in a non-deployed configuration. In this embodiment, gripper 108 includes two pairs of opposing bendable gripping members 118. Two of the bendable gripping members 118 are shown in Figure 3, while the other two (not shown in Figure 3) are located at the same axial location but offset by

90 degrees. Each bendable gripping member 118 has a thinned portion 120 that permits bending as the opposite distal end 122 of member 118 is urged radially outward, such that member 118 pivots about thinned portion 120. When extended, distal ends 122 of bendable members 118 contact the inside of the bone to anchor the distal portion of device 100 to the bone. In
5 alternative embodiments (not shown), the gripper may comprise 1, 2, 3, 4, 5, 6 or more bendable members similar to members 118 shown.

[000134] During actuation, bendable members 118 of gripper 108 are urged radially outward by a ramped surface on actuator head 124. Actuator head 124 is formed on the distal end of actuator 126. The proximal end of actuator 126 is threaded to engage a threaded bore of drive
10 member 128. The proximal end of drive member 128 is provided with a keyed socket 130 for receiving the tip of a rotary driver tool 132 (shown in Figures 4 and 5) through the proximal bore of device 100. As rotary driver tool 132 turns drive member 128, actuator 126 is drawn in a proximal direction to outwardly actuate gripper members 118.

[000135] A hemispherical tip cover 134 may be provided at the distal end of the device as
15 shown to act as a blunt obturator. This arrangement facilitates penetration of bone (e.g. an intramedullary space) by device 100 while keeping the tip of device 100 from digging into bone during insertion .

[000136] As previously mentioned, device 100 may include one or more flexible-to-rigid body portions 114. This feature is flexible upon entry into bone and rigid upon application of
20 compressive axial force provided by tensioning actuator 126. Various embodiments of a flexible-to-rigid portion may be used, including dual helical springs whose inner and outer tubular components coil in opposite directions, a chain of ball bearings with flats or roughened surfaces, a chain of cylinders with flats, features, cones, spherical or pointed interdigitating surfaces, wavy-helical cut tubes, two helical cut tubes in opposite directions, linear wires with
25 interdigitating coils, and bellows-like structures.

[000137] The design of the flexible-to-rigid tubular body portion 114 allows a single-piece design to maximize the transformation of the same body from a very flexible member that minimizes strength in bending to a rigid body that maximizes strength in bending and torsion. The flexible member transforms to a rigid member when compressive forces are applied in the
30 axial direction at each end, such as by an actuator similar to 126. The body portion 114 is made, for example, by a near-helical cut 116 on a tubular member at an angle of incidence to the axis somewhere between 0 and 180 degrees from the longitudinal axis of the tubular body portion 114. The near-helical cut or wavy-helical cut may be formed by the superposition of a helical curve added to a cyclic curve that produces waves of frequencies equal or greater than zero per
35 turn around the circumference and with cyclic amplitude greater than zero. The waves of one

segment nest with those on either side of it, thus increasing the torque, bending strength and stiffness of the tubular body when subjected to compressive forces. The tapered surfaces formed by the incident angle allow each turn to overlap or interdigitate with the segment on either side of it, thus increasing the bending strength when the body is in compression. Additionally, the cuts can be altered in depth and distance between the cuts on the longitudinal axis along the length of body portion 114 to variably alter the flexible-to-rigid characteristics of the tubular body along its length.

[000138] The cuts 116 in body portion 114 allow an otherwise rigid member to increase its flexibility to a large degree during deployment. The tubular member can have constant or varying internal and external diameters. This design reduces the number of parts of the flexible-to-rigid body portion of the device and allows insertion and extraction of the device through a curved entry port in the bone while maximizing its rigidity once inserted. Application and removal of compressive forces provided by a parallel member such as wire(s), tension ribbons, a sheath, wound flexible cable, or actuator 126 as shown will transform the body from flexible to rigid and vice versa.

[000139] In operation, as actuator 126 is tightened, gripper members 118 are extended radially outwardly. Once the distal ends of gripper members 118 contact bone and stop moving outward, continued rotation of actuator 126 draws the proximal end 102 and the distal end 104 of device 100 closer together until cuts 116 are substantially closed. As this happens, body portion 114 changes from being flexible to rigid to better secure the bone fracture(s), as will be further described below. Rotating drive member 128 in the opposite direction causes body portion 114 to change from a rigid to a flexible state, such as for removing device 100 if needed in the initial procedure or during a subsequent procedure after the bone fracture(s) have partially or completely healed. Body portion 114 may be provided with a solid longitudinal portion 136 (as best seen in Figures 3 and 9B) such that cuts 116 are a series of individual cuts each traversing less than 360 degrees in circumference, rather than a single, continuous helical cut. This solid portion 136 can aid in removal of device 100 by keeping body portion 114 from extending axially like a spring.

[000140] Figure 4 illustrates a combination tool 138 useful for inserting device 100, actuating gripper 108, compressing flexible-to-rigid body portion 114, approximating the fracture in bone 106, aligning anchor screw(s) 110, and removing device 100, if desired. In this exemplary embodiment, tool 138 includes an L-shaped body 140 that mounts the other components of the tool and also serves as a handle. The main components of tool 138 are a device attachment portion 142, a rotary driver 132, an approximating driver 144, and a screw alignment portion 146.

[000141] Figure 5 shows a cross-section of the tool 138 and device 100 illustrated in Figure 4.

As shown, device attachment portion 142 includes a knob 148 rigidly coupled to a tube 150 which is rotatably mounted within sleeve 152. Sleeve 152 in turn is fixedly mounted to tool body 140. The distal end of tube 150 is provided with external threads for engaging the internal threads on the proximal end of device 100. As best seen in Figure 4, both the distal end of sleeve 152 and the proximal end of device 100 may be provided with semicircular steps that inter-engage to prevent device 100 from rotating with respect to sleeve 152. With this arrangement, device 100 can be prevented from rotating when it is secured to tool 138 by tube 150 of device attachment portion 142. The mating semicircular steps also serve to position device 100 in a particular axial and angular orientation with respect to tool 138 for aligning screws with screw holes, as will be later described.

[000142] Rotary driver 132 may be used to actuate gripper 108 and compress flexible-to-rigid body portion 114 after device 100 is inserted into bone 106. Driver 132 may also be used to allow body portion 114 to decompress and gripper 108 to retract if removal of device 100 from bone 106 is desired. In the embodiment shown, driver 132 includes knob 154, torsion spring 156, hub 158, bushing 160 and shaft 162. The distal end of shaft 162 is provided with a mating tip 164, such as one having a hex-key shape, for engaging with keyed socket 130 of device 100 (best seen in Figure 3), such that turning driver shaft 162 turns drive member 128 and axially actuates actuator 126, as described above.

[000143] The proximal end of shaft 162 may be fitted with a bushing 160, such as with a press-fit. Hub 158 may be secured over bushing 160, such as with a pin through bushing 160 and shaft 162. In this embodiment, knob 154 is rotatably mounted over hub 158 and bushing 160 such that knob 154 can rotate independently from shaft 162. A torsion spring 156 may be used to couple knob 154 to hub 158 as shown to create a torque limiting and/or torque measuring driver. With this indirect coupling arrangement, as knob 154 is rotated about shaft 162, spring 156 urges hub 158 and shaft 162 to rotate in the same direction. Rotational resistance applied by device 100 to shaft tip 164 will increase in this embodiment as gripper 108 engages bone 106, and flexible-to-rigid body portion 114 compresses. As more torque is applied to knob 154, it will advance rotationally with respect to hub 158 as torsion spring 156 undergoes more stress. Markings may be provided on knob 154 and hub 158 to indicate the torque being applied. In this manner, a surgeon can use driver 132 to apply torque to device 100 in a predetermined range. This can help ensure that gripper 108 is adequately set in bone 106, body portion 114 is sufficiently compressed, and excessive torque is not being applied that might damage device 100, bone 106 or cause slippage there between. A slip clutch or other mechanism may be provided to allow the applied torque to be limited or indicated. For example, driver 132 may be configured to "click"

into or out of a detent position when a desired torque is reached, thus allowing the surgeon to apply a desired torque without needing to observe any indicia on the driver. In alternative embodiments, the driver knob may be selectably or permanently coupled to shaft 162 directly.

[000144] After device 100 is inserted in bone 106 and deployed with tool 138 as described

5 above, the approximating driver portion 144 of tool 138 may be used to compress one or more fractures in bone 106. Approximating driver 144 includes knob 166 located on sleeve 152.

Knob 166 may be knurled on an outer circumference, and have threads on at least a portion of its axial bore. The internal threads of knob 166 engage with mating external threads on sleeve 152 such that when knob 166 is rotated it advances axially with respect to sleeve 152. When device

10 100 is anchored in bone 106, sleeve 152 is prevented from moving away from the bone.

Accordingly, as knob 166 is advanced axially toward bone 106, it serves to approximate bone fractures located between gripper 108 and knob 166. Suitable thread pitch and knob

circumference may be selected to allow a surgeon to supply a desired approximating force to bone 106 by using a reasonable rotation force on knob 166. In alternative embodiments (not

15 shown), a torque indicating and/or torque limiting mechanism as described above may be incorporated into approximating driver 144.

[000145] As previously indicated, tool 138 may also include a screw alignment portion 146. In the embodiment depicted in the figures, alignment portion 146 includes a removable alignment tube 168 and two bores 170 and 172 through tool body 140. In alternative embodiments (not

20 shown), a single bore or more than two bores may be used, with or without the use of separate alignment tube(s).

[000146] In operation, alignment tube 168 is first received in bore 170 as shown. In this

position, tube 168 is in axial alignment with angled hole 174 at the distal end 102 of device 100. As described above, the mating semicircular steps of device 100 and sleeve 152 position angled

25 hole 174 in its desired orientation. With this arrangement, a drill bit, screw driver, screw and/or other fastening device or tool may be inserted through the bore of tube 168 such that the device(s) are properly aligned with hole 174. The outward end of alignment tube 168 may also serve as a depth guide to stop a drill bit, screw and/or other fastener from penetrating bone 106 beyond a predetermined depth.

30 **[000147]** Alignment tube 168 may be withdrawn from bore 170 as shown, and inserted in bore 172. In this position, tube 168 aligns with hole 176 of device 100. As described above, a drill bit, screw driver, screw and/or other fastening device may be inserted through the bore of tube 168 such that the device(s) are properly aligned with hole 176.

[000148] Figure 6 shows alignment tube 168 of tool 138 aligning screw 110 with angled hole

35 174 at the distal end of device 100, as described above.

[000149] Figure 7 shows a first screw 110 received through angled hole 174 and a second screw 110 received through hole 176 in device 100 and into bone 106. Screws 110 may be installed manually or with the aid of tool 138 as described above. The heads of screws 110 may be configured to be self-countersinking such that they remain substantially beneath the outer surface of the bone when installed, as shown, so as to not interfere with adjacent tissue. In this embodiment, the proximal end 102 of device 100 is secured to bone 106 with two screws 110, and the distal end 104 is secured by gripper 108. In this manner, any bone fractures located between the proximal screw 110 and distal gripper 108 may be approximated and rigidly held together by device 100. In alternative embodiments (not shown), more than one gripper may be used, or only screws or other fasteners without grippers may be used to secure device 100 within bone 106. For example, the device shown in Figure 1 could be configured with a second gripper located between screw 110 and the middle of the device if the fracture is located more at the mid-shaft of the bone. Similarly, more than two screws or other fasteners may be used, or only grippers without fasteners may be used. In various embodiments, holes such as 174 and 176 as shown and described above can be preformed in the implantable device. In other embodiments, some or all of the holes can be drilled or otherwise formed *in situ* after the device is implanted in the bone.

[000150] Once device 100 is secured within bone 106, combination tool 138 may be removed by turning knob 148 to disengage threads of tube 150 from threads within the proximal end 102 of device 100. An end plug 178 may be threaded into the proximal end 102 of device 100 to prevent ingrowth of tissue into implanted device 100. Device 100 may be left in bone 106 permanently, or it may be removed by performing the above described steps in reverse. In particular, plug 178 is removed, tool 138 is attached, screws 110 are removed, gripper 108 is retracted, and device 100 is pulled out using tool 138.

[000151] Figure 8 shows an alternative embodiment of a combination tool 138' useful for inserting device 100, actuating gripper 108, compressing flexible-to-rigid body portion 114, approximating the fracture in bone 106, aligning anchor screw(s) 110, and removing device 100, if desired. Like tool 138 described above, exemplary tool 138' includes an L-shaped body 140' that mounts the other components of the tool and also serves as a handle. The main components of tool 138' are a device attachment portion 142, a rotary driver 132, an approximating driver 144, and a screw alignment portion 146. These components are constructed and function in a similar fashion to the components of tool 138 described above. Tool 138' is constructed to allow one or more screw holes to be formed *in vivo*, and/or allow screw(s) to be aligned with such screw holes or preformed screw holes, through flexible-to-rigid body portion 114 of device 100. Tool 138' may be configured to allow the screw hole(s) may be formed at an angle through body

portion 114, and/or formed perpendicularly to the longitudinal axis of device 100. Tool 138' may also include the capability to form screw holes or align screws for insertion in the proximal hub portion of device 100 as described above.

5 [000152] Tool 138' may be used to form screw hole(s) in flexible-to-rigid body portion 114 by guiding a drill bit with alignment tube 168. Screw hole(s) may also be formed directly in body portion 114 without pre-forming or drilling holes *in vivo*, but by placing a screw directly into body portion 114, such as with a self-tapping screw guided with alignment tube 168.

10 [000153] Internal components within device 100, such as actuator 126, may be configured such that screw(s) pass through it or pass around it. For example, in some embodiments the actuator comprises one or more cables, leaving enough room within body portion 114 so that a screw can avoid the actuator(s), or move it/them out of the way when passing into or through body portion 114. In some embodiments, the one or more actuators are large enough to allow one or more screws to pass through it/them without impeding the operation of the actuator(s). In some
15 embodiments, the screw(s) only enter one wall of tubular body portion 114 without entering the interior space of the body portion.

[000154] Figures 9A and 9B show alternative embodiments similar to device 100 described above. Device 100' shown in Figure 9A is essentially identical to device 100 described above but is shorter in length and utilizes a single anchor screw 110 at its proximal end 102. Device 100'' shown in Figure 9B is similar to device 100', but is shorter still. In various embodiments,
20 the devices may be configured to have a nominal diameter of 3mm, 4mm, 5mm or 6mm. It is envisioned that all three device designs 100, 100' and 100'' may each be provided in all three diameters such that the chosen device is best suited for the particular fracture(s) and anatomy in which it is implanted.

[000155] In accordance with the various embodiments of the present invention, the device may
25 be made from a variety of materials such as metal, composite, plastic or amorphous materials, which include, but are not limited to, steel, stainless steel, cobalt chromium plated steel, titanium, nickel titanium alloy (nitinol), superelastic alloy, and polymethylmethacrylate (PMMA). The device may also include other polymeric materials that are biocompatible and provide mechanical strength, that include polymeric material with ability to carry and delivery
30 therapeutic agents, that include bioabsorbable properties, as well as composite materials and composite materials of titanium and polyetheretherketone (PEEK™), composite materials of polymers and minerals, composite materials of polymers and glass fibers, composite materials of metal, polymer, and minerals.

[000156] Within the scope of the present invention, each of the aforementioned types of device
35 may further be coated with proteins from synthetic or animal source, or include collagen coated

structures, and radioactive or brachytherapy materials. Furthermore, the construction of the supporting framework or device may include radio-opaque markers or components that assist in their location during and after placement in the bone or other region of the musculo-skeletal systems.

5 [000157] Further, the reinforcement device may, in one embodiment, be osteo incorporating, such that the reinforcement device may be integrated into the bone.

[000158] In a further embodiment, there is provided a low weight to volume device deployed in conjunction with other suitable materials to form a composite structure in-situ. Examples of such suitable materials may include, but are not limited to, bone cement, high density
10 polyethylene, Kapton® , polyetheretherketone(PEEK™), and other engineering polymers.

[000159] Once deployed, the device may be electrically, thermally, or mechanically passive or active at the deployed site within the body. Thus, for example, where the device includes nitinol, the shape of the device may be dynamically modified using thermal, electrical or mechanical manipulation. For example, the nitinol device may be expanded or contracted once deployed, to
15 move the bone or other region of the musculo-skeletal system or area of the anatomy by using one or more of thermal, electrical or mechanical approaches.

[000160] It is contemplated that the inventive implantable device, tools and methods may be used in many locations within the body. Where the proximal end of a device in the anatomical context is the end closest to the body midline and the distal end in the anatomical context is the
20 end further from the body midline, for example, on the humerus, at the head of the humerus (located proximal, or nearest the midline of the body) or at the lateral or medial epicondyle (located distal, or furthest away from the midline); on the radius, at the head of the radius (proximal) or the radial styloid process(distal); on the ulna, at the head of the ulna (proximal) or the ulnar styloid process (distal); for the femur, at the greater trochanter (proximal) or the lateral
25 epicondyle or medial epicondyle (distal); for the tibia, at the medial condyle(proximal) or the medial malleolus (distal); for the fibula, at the neck of the fibula (proximal) or the lateral malleolus(distal); the ribs; the clavicle; the phalanges; the bones of the metacarpus; the bones of the carpus; the bones of themetatarsus; the bones of the tarsus; the sternum and other bones, the device may be adapted and configured with adequate internal dimension to accommodate
30 mechanical fixation of the target bone and to fit within the anatomical constraints. As will be appreciated by those skilled in the art, access locations other than the ones described herein may also be suitable depending upon the location and nature of the fracture and the repair to be achieved. Additionally, the devices taught herein are not limited to use on the long bones listed above, but can also be used in other areas of the body as well, without departing from the scope

of the invention. It is within the scope of the invention to adapt the device for use in flat bones as well as long bones.

[000161] Figures 10A-10I show another embodiment of a bone fixation device constructed according to aspects of the invention. Figure 10A is a perspective view showing the exemplary device 200 deployed in a fractured clavicle 202. Device 200 is similar to device 100 described above and shown in Figures 1-7, but has a gripper 204 located near its proximal end, another gripper 206 located at a more distal location, and a flexible-to-rigid body portion 208 located near the distal end of the device. A bone screw 210 and gripper 204 are configured to secure device 200 inside bone 202 on the proximal side of fracture 212, while gripper 206 and flexible-to-rigid body portion 208 are configured to secure device 200 on the distal side of fracture 212. In other respects, construction and operation of device 200 is much like that of device 100 described above.

[000162] In this exemplary embodiment, each of the two grippers 204 and 206 has four outwardly expanding arms 214. These arms are spaced at 90 degree intervals around the circumference of the device body. The arms 214 of gripper 204 may be offset by 45 degrees from arms 214 of gripper 206 as shown in the figures to distribute the forces applied by grippers 204 and 206 on the bone 202. As shown in Figures 10E and 10F, a single actuator 216 may be used to deploy both grippers 204 and 206. Actuator 216 may also be used to axially compress flexible-to-rigid body portion 208 to make it substantially rigid. At least a portion of actuator 216 may be flexible to allow flexible-to-rigid body portion 208 to assume a curved shape, as best seen in Figures 10A and 10B. Alternatively, it may be desirable in some embodiments to have flexible-to-rigid body portion 208 maintain a straight or a curved configuration regardless of whether it is in a flexible or rigid state. In these embodiments, the actuator may be rigid and formed with the desired straight and/or curved shape to match the flexible-to-rigid body portion. In some embodiments, it may also be desirable to design at least a portion of the actuator with a high degree of axial elasticity to allow the actuator to continue to expand some gripper(s) and/or compress some flexible-to-rigid body portion(s) after other gripper(s) and/or flexible-to-rigid body portion(s) have already been fully deployed.

[000163] Referring to Figures 10G-10I, further details of an exemplary gripper 204 are shown. Figures 10G and 10H show gripper 204 with bendable arms 214 in a retracted state. As cam 218 of actuator 216 is driven axially into the distal ramped ends of arms 214, arms 214 bend at thinned portions 220 to move radially outward toward the deployed position shown in Figure 10I. Notches 222 may be provided in the distal ends of arms 214 as shown to allow arms 214 to better grip interior bone surfaces. Without departing from the scope of the invention, one, two, three, or more bendable arms may be used.

[000164] Referring to Figures 11A-11D, another embodiment of a bone fixation device is shown. Device 300 includes a curved hub 302, proximal gripper 304, flexible-to-rigid body portion 306, and distal gripper 308. Distal gripper 308 is similar in construction and operation to grippers 204 and 206 described above. Proximal gripper 304 is provided with three pairs of scissor arms 310. Each pair of arms 310 is pivotably interconnected at a mid-portion by a pin. Each arm is pivotably connected with a pin to either proximal end piece 312 or distal end piece 314. When end pieces 312 and 314 are moved closer together, arms 310 pivot radially outward from an axially aligned retracted position, as shown in Figures 11A and 11C, to a deployed position, as shown in Figures 11B and 11D. In the deployed position, the distal ends of the six arms 310 engage an inner surface of a bone as previously described.

[000165] In operation, device 300, with grippers 304 and 308 in a retracted state, may be inserted into the intramedullary space within a bone, such as the radius. Device 300 may be inserted through a curved opening formed in the bone, such as an opening formed through a bony protuberance on a distal or proximal end or through the midshaft of the bone. Curved hub 302 may be configured with the same geometry of the curved opening in the bone, and when the flexible-to-rigid body portion 306 is in its flexible state, it can assume this same geometry. Once device 300 is in place inside the bone, actuator 315 (shown in Figures 11C and 11D) may be actuated from the proximal end of device 300 by turning drive member 317 in a manner similar to that previously described. Longitudinal movement of actuator 315 toward the proximal end of device 300 causes flexible-to-rigid body portion 306 to foreshorten and assume its rigid state, and causes grippers 304 and 308 to outwardly deploy against the bone. Bone screws may be inserted through holes 316 shown in curved hub 302 to secure the proximal end of device 300 to the bone. Further details of the construction and operation of a device similar to device 300 may be found in co-pending U.S. application serial no. 11/944,366 filed November 21, 2007 and entitled Fracture Fixation Device, Tools and Methods.

[000166] Device 300 is an example of an embodiment utilizing mixed gripper types. In other words, this device uses one scissors-arm tripod gripper 304 and one bendable-arm gripper 308. Other embodiments of the invention (not shown) use various combinations of gripper(s) and/or flexible-to-rigid body portion(s). Further exemplary gripper embodiments are described in detail below. It is envisioned that virtually any combination of zero, one, two, or more grippers may be used in combination with zero, one, two or more flexible-to-rigid body portions to form a device adapted to a particular bone anatomy, fracture, disease state or fixation purpose. The grippers and/or flexible-to-rigid body portions may each be of identical or different construction, and may be placed together or at other locations along the device. Further, a straight, curved, flexible, rigid, or no hub at all may be used with the above combinations. Additionally, screws, K-wires,

sutures or no additional fixation may be used with these various devices. The devices may be specially designed and constructed for a particular purpose or range of purposes. According to aspects of the invention, the components may also be designed to be interchangeable and/or produced in various sizes so that surgical kits may be provided. Such kits would allow surgical teams to select from a variety of components to build devices themselves, each suited to a particular patient's unique situation.

[000167] Figures 12A through 21B show alternative gripper embodiments that may be used with the above described bone fixation devices, or with similar devices. Each of the following gripper embodiments may be provided at one or more locations along the length of the device.

Each gripper is designed to have a retracted state for allowing a bone fixation device to be inserted into a bone, and an expanded state to secure the device within the bone. Each gripper arrangement includes fixation elements that are in a radially inward position when in the retracted state. Upon axial compression of each of the grippers, the fixation elements are deployed radially outward to contact interior bone surfaces, such as those defining an intramedullary space along the longitudinal axis of the bone, as described above. Each gripper design may optionally be provided with a threaded end to engage an actuator for moving the gripper between the retracted and expanded states.

[000168] Referring to Figures 12A-12G, one alternative gripper embodiment is shown.

Gripper 400 includes a proximal end piece 402 with two long arms 404 each pivotably connected at their proximal ends to proximal end piece 402 by a pin 406. (Again, the words "proximal" and "distal" are being used herein with reference to the surgeon rather than to the patient's anatomy.) Gripper 400 also includes a distal end piece 408 with two short arms 410 each pivotably connected at their proximal ends to distal end piece 408 by a pin 412. A distal portion of each long arm 404 is pivotably connected to a mid-portion of each short arm 410 by a pin 414, thereby forming two pairs of scissor-arms, each pair spanning between end pieces 402 and 408.

[000169] Gripper 400 is movable between a retracted state in which short arms 410 are substantially aligned with the longitudinal axis of gripper 400 (as shown in Figures 12A, 12C and 12E) and a deployed state in which the short arms are pivoted radially outward (as shown in Figures 12B, 12D and 12F). Gripper 400 is moved from the retracted state to the deployed state by axially compressing end pieces 402 and 408 towards one another, such as with a pull-wire or screw actuator as previously described. Gripper 400 may be returned from the deployed state to the retracted state by applying an axially tensile force to end pieces 402 and 408. In the deployed state, the distal ends 416 of short arms 410 engage the inner surface of the bone (not shown). Depending on the penetration depth of distal ends 416 of short arms 410 into the bone, the distal ends 418 of long arms 404 may provide additional bone gripping.

[000170] Proximal end piece 402 is provided with recesses 420 to receive distal ends 416 of short arms 410 when in the retracted position. Proximal end piece 402 is also provided with recesses 422 to receive long arms 404, particularly when in the deployed position.

[000171] The particular arrangement of gripper 400 provides high contact force even at low deployment angles. This is achieved by the long moment arms of long arms 404 crossing over the center of gripper 400 to create higher compressive forces. Therefore, this arrangement does not need to expand as much as the scissors gripper 304 described previously to become effective. By comparison, gripper 400 has a large difference in direction and distance at the root of the center-line compressive forces running along the two arms to create a large expansive moment that produces a large contact force even when the device is just starting to expand.

[000172] Referring to Figures 13A-13H, another gripper embodiment 500 is shown. Gripper 500 is similar to gripper 400 described above in that it includes high moment arms crossing over the centerline of the gripper to provide high contact forces even at low expansion angles.

Gripper 500, however, includes three sets of scissor-arm pairs instead of two, providing two contact areas every 120 degrees around the gripper instead of every 180 degrees as does gripper 400. While embodiments having two and three sets of gripper arms are shown, other embodiments of the invention (not shown) may use only a single set of arms or more than three sets. Additionally, while the arm sets shown each have two arms, it is envisioned that each "set" of arms may include a single arm pinned to the two end pieces, or more than two arms.

[000173] Gripper 500 includes a first end piece 502 with three long arms 504 each pivotably connected at their proximal ends to first end piece 502 by a pin 506. First end piece 502 is provided with recesses 520 to receive long arms 504, as best seen in Figure 13E. Gripper 500 also includes a second end piece 508 with three short arms 510 each pivotably connected at their proximal ends to second end piece 508 by a pin 512. Second end piece 508 is provided with recesses 522 to receive short arms 510. A distal portion of each long arm 504 is pivotably connected to a distal portion of each short arm 510 by a pin 514, thereby forming three pairs of scissor-arms, each pair spanning between end pieces 502 and 508.

[000174] Gripper 500 is movable between a retracted state in which short arms 510 are substantially aligned with the longitudinal axis of gripper 500 (as shown in Figures 13A, 13C and 13F) and a deployed state in which the short arms 510 are pivoted radially outward (as shown in Figures 13B, 13D and 13G). Gripper 500 may be moved from the retracted state to the deployed state by axially compressing end pieces 502 and 508 towards one another, such as with an actuator as previously described. Gripper 500 may be returned from the deployed state to the retracted state by applying an axially tensile force to end pieces 502 and 508. In the deployed state, the distal ends 516 of short arms 510 and the distal ends 518 of long arms 504 engage the

inner surface of the bone (not shown). Notches may be formed on the inside edges of each of the arms as shown so that they do not interfere with other components when in the retracted or deployed positions. Advantages of gripper 500 include a high gripping force at low radial expansion, and an ability to stabilize a bone fixation device in an intramedullary space having a circular or elliptical cross-section by gripping at three locations around the circumference.

5 [000175] Referring to Figures 14A-14H, another gripper embodiment 600 is shown. Gripper 600 includes a first end piece 602 with three pairs of short arms 604 each pivotably connected at their proximal ends to first end piece 602. First end piece 602 is provided with six recesses 620 to receive short arms 604, as best seen in Figure 14G. A pin 606 is used to pivotably secure each of the three pairs of short arms 604 to first end piece 602. Gripper 600 also includes a second end piece 608, which may be constructed to be identical to first end piece 602. Second end piece 608 also includes six recesses 620 to receive another three pairs of short arms 604. These additional three pairs of short arms 604 are pivotably secured at their proximal ends to second end piece 608 with three more pins 606. A distal end of each pair of short arms 604 connected to first end piece 602 is pivotably connected to one end of a long arm 610 by a pin 614. In a similar manner, a distal end of each pair of short arms 604 connected to second end piece 608 is pivotably connected to the opposite end of a long arm 610 by a pin 614. This arrangement forms three sets of arms spanning between first end piece 602 and second end piece 608. For clarity, only one of these three sets of arms is shown in Figure 14H. As seen in Figure 14H, each set of arms includes one long arm 610 and four short arms 604, all pivotably interconnected by two pins 614 and pivotably secured to the end pieces 602 and 608 by two pins 606. In other embodiments (not shown), each set of arms may include two long arms 610 instead of one, and/or two short arms 604 instead of four (one short arm 604 located at each end of the long arm(s) 610). Also, in other embodiments, one, two, four, or more sets of arms may be used instead of three. Radially outward facing surfaces of long arms 610 may be provided with serrations as shown for increased bone gripping capability.

10 15 20 25 30 35 [000176] Gripper 600 is movable between a retracted state in which long arms 610 are substantially aligned with the longitudinal axis of gripper 600 and in a radially inward position (as shown in Figures 14A, 14C and 14E) and a deployed state in which long arms 610 remain substantially aligned with the gripper axis but are moved to a radially outward position by pivoting short arms 604 (as shown in Figures 14B, 14D and 14F). Gripper 600 may be moved from the retracted state to the deployed state by axially compressing end pieces 602 and 608 towards one another, such as with an actuator as previously described. Gripper 600 may be returned from the deployed state to the retracted state by applying an axially tensile force to end pieces 602 and 608. In the deployed state, outwardly facing serrations of long arms 610 and the

distal ends of short arms 604 engage the inner surface of the bone (not shown). The arrangement of gripper 600 distributes the radial pressure of the gripping arms over a larger cylinder within the bone. Three lines of contact are formed, spaced at every 120 degrees. Small holes may be provided in arms 604 and 610 as shown, and positioned such that the holes align when the gripper is in the retracted state. By inserting small pins or wires into the holes, the gripper may be temporarily locked in the retracted state. This may be useful when an intramedullary device requires significant pushing force to insert into the bone.

[000177] Referring to Figures 15A-15H, another gripper embodiment 700 is shown. Gripper 700 includes a first end piece 702 with three short arms 704 each pivotably connected at their proximal ends to first end piece 702. First end piece 702 is provided with three recesses 720 to receive short arms 704, as best seen in Figure 15G. Pins 706 are used to pivotably secure each of the three short arms 704 to first end piece 702. Gripper 700 also includes a second end piece 708, which may be constructed to be identical to first end piece 702. Second end piece 708 also includes three recesses 720 to receive another three short arms 704. These additional three short arms 704 are pivotably secured at their proximal ends to second end piece 708 with three more pins 706. A distal end of each short arm 704 connected to first end piece 702 is pivotably connected to one end of a long arm 710 by a pin 714. In a similar manner, a distal end of each short arm 704 connected to second end piece 708 is pivotably connected to the opposite end of a long arm 710 by a pin 714. This arrangement forms three sets of arms spanning between first end piece 702 and second end piece 708. For clarity, only one of these three sets of arms is shown in Figure 15H. As seen in Figure 15H, each set of arms includes one long arm 710 and two short arms 704, all pivotably interconnected by two pins 714 and pivotably secured to the end pieces 702 and 708 by two pins 706. With this arrangement, each long arm 710 connects two coplanar short arms 704 generally situated 120 degrees apart from each other. In other embodiments (not shown), each set of arms may include two long arms 710 instead of one, and/or four short arms 704 instead of two (two short arms 704 located at each end of the long arm(s) 710). Also, in other embodiments, one, two, four, or more sets of arms may be used instead of three.

[000178] Gripper 700 is movable between a retracted state in which short arms 704 are substantially aligned with the longitudinal axis of gripper 700 (as shown in Figures 15A, 15C and 15E) and a deployed state in which short arms 704 are pivoted radially outward (as shown in Figures 15B, 15D and 15F). Gripper 700 may be moved from the retracted state to the deployed state by axially compressing end pieces 702 and 708 towards one another, such as with an actuator as previously described. Gripper 700 may be returned from the deployed state to the retracted state by applying an axially tensile force to end pieces 702 and 708. In the deployed

state, the pointed distal ends of short arms 704 engage the inner surface of the bone (not shown). The arrangement of gripper 700 distributes the radial pressure of the gripping arms over six points of contact with the bone, as best seen in Figure 15F. Three lines of contact are formed, spaced at every 120 degrees.

5 [000179] It should be noted here that each long arm 710 of gripper 700 is oriented at an angle with respect to the longitudinal axis of the gripper when in the retracted position. This angle increases as gripper 700 is moved into the deployed position. This arrangement provides the advantage of high expansion forces at low expansion angles, similar to the grippers of Figures 12A-12G and 13A-13H described above. It should also be noted that each long arm 710 has an
10 inward surface that is flat and an outward surface that is contoured to match the cylindrical projection of end pieces 702 and 708 when gripper 700 is in the retracted state. This allows gripper 700 to be easily introduced into a bone. The particular arrangement of gripper 700 also advantageously centers itself and an attached fixation device inside an intramedullary space when being deployed.

15 [000180] Various descriptive terms such as “long arm” and “short arm” have been used in the above discussions to aid the reader in understanding the embodiments of the present invention. It should be noted that these terms are not meant to be limiting, as in some embodiments a “long arm” may be constructed to be longer, shorter, or of equal length as the “short arm”. Similarly, all of the components described as either “long arms” or “short arms” in any particular
20 embodiment do not necessarily need to be the same length.

[000181] Referring to Figures 16A-16D, a tubular gripper embodiment is shown. Gripper 800 is generally tube-shaped and has a series of slots 802 formed through its wall thickness along the length and around the circumference of the tube. In this embodiment, each slot 802 is helical, as shown. In other embodiments, the slots may be straight or form other patterns. Slots 802 may
25 be formed by laser cutting, punching, milling, etching, sawing, electro-discharge machining, or otherwise removing material from the body of the gripper. Slots 802 may also be created by molding, extruding or otherwise forming the beam members 804 between the slots 802. Gripper 800 may be formed from metal, composite, plastic, amorphous materials, shape memory alloy, and/or other suitable materials.

30 [000182] Figures 16A and 16 B show gripper 800 in a retracted state. By applying a compressive axial load to the ends of gripper 800 as with the previously described grippers, gripper 800 expands radially outward into a deployed state, as shown in Figures 16C and 16D. In the deployed state, mid-portions of beam members 804 arc outwardly to contact an inner surface of bone to anchor an attached fixation device to the bone. By applying a tensile force to
35 the ends of gripper 800, it may be at least partially returned to the retracted state. In some

embodiments of the invention, beam members 804 undergo only elastic deformation when moving into the deployed state. In other embodiments, members 804 may undergo plastic deformation.

[000183] In some embodiments, a bone fixation device incorporating gripper(s) 800 may rotationally constrain the ends of the gripper relative to one another as the ends move axially. In other embodiments, the ends may be left unconstrained. In still other embodiments, the ends of gripper 800 may be biased or forced to rotate relative to one another as they move axially closer and/or farther apart. Such arrangements may advantageously increase or decrease the amount of expansion that occurs when the gripper is axially compressed, and/or may similarly alter the amount of retraction that occurs when the gripper is axially pulled under tension.

[000184] Figures 17A and 17B show another tubular gripper embodiment. Gripper 900 is similar to gripper 800, but beam members 904 each have an offset portion 906 located at their mid-portions. These offset portions 906 create a pair of sharp points on opposite sides of each beam member that can enhance the gripping effectiveness of gripper 900 by engaging with the interior bone surface when the gripper is deployed.

[000185] Figures 18A and 18B show another tubular gripper embodiment. Gripper 1000 is similar to both grippers 800 and 900. Gripper 1000 includes a protruding member 1006 located along each side of each beam member 1004. Pointed ends of opposite facing protruding members 1006 provide additional gripping engagement when gripper 1000 is deployed.

[000186] Figures 19A and 19B show another tubular gripper embodiment. Gripper 1100 includes a first series of beam members 1104 helically extending from a first end of the gripper, and a second series of opposing beam members 1106 helically extending from the opposite end of the gripper and which interdigitate with the first series 1104. The first series of beam members 1104 are interconnected with the second series 1106 by a series of short leaf springs 1108 around the mid-circumference of gripper 1100. As gripper 1100 axially compresses and beam members 1104 and 1106 bend toward a deployed state, the distal ends 1110 of members 1104 and 1106 engage with the interior surface of the bone.

[000187] Figures 20A and 20B show another tubular gripper embodiment. Gripper 1200 of this embodiment is similar to gripper 1100 of the previous embodiment, but fewer beam members 1204 and 1206 are employed in gripper 1200, and the beam members 1204 and 1206 are interconnected with longer, Z-shaped leaf springs 1208. As gripper 1200 axially compresses and beam members 1204 and 1206 bend toward a deployed state, the distal ends 1210 of members 1204 and 1206 engage with the interior surface of the bone.

[000188] Figures 21A and 21B show another tubular gripper embodiment. Gripper 1300 of this embodiment is also similar to gripper 1100 shown in Figures 19A and 19B, but the beam

members 1304 and 1306 are interconnected with serpentine leaf springs 1308. As gripper 1300 axially compresses and beam members 1304 and 1306 bend toward a deployed state, the distal ends 1310 of members 1304 and 1306 engage with the interior surface of the bone.

5 [000189] In any of the above-described tubular gripper embodiments, a thinned down portion (not shown) may be provided at a predetermined location or locations along one or more of the beam members to cause the beam member to bend at that particular location during deployment under axial compressive loading.

10 [000190] Figures 22A-22F show another exemplary embodiment of a bone fixation device 1400 constructed according to aspects of the present invention. Device 1400 includes a curved hub 1402, a proximal gripper 1404, a flexible-to-rigid body portion 1406, a distal gripper 1408, and an actuation lead screw 1410. Figures 22A-22C show device 1400 in an undeployed state, while Figures 22D-22F show device 1400 in a deployed state.

15 [000191] Figures 23A-23G show further details of distal gripper 1408 of device 1400 described above. As best seen in Figure 23G, distal gripper 1408 comprises a proximal end piece 1450, a distal end piece 1452, a tubular core 1454, a first gripper arm 1456, a second gripper arm 1458, two link bars 1460, 1460, two long pins 1462, 1462, and two short pins 1464, 1464.

20 [000192] Tubular core 1454 may include a flange 1466 at its distal end as shown for engaging in a circular bore 1468 in the distal side of distal end piece 1452 for transferring axial loads. Tubular core 1454 may be fastened to distal end piece 1452, such as by a press fit and/or welding. Proximal end piece 1450 includes a central opening for receiving the tubular core 1454 such that proximal end piece may freely slide along the tubular core 1454.

25 [000193] Upper portions of both first and second gripper arms 1456, 1458 are pivotably connected to proximal link bar 1460 by a single long pin 1462. Proximal link bar 1460 in turn is pivotably connected to proximal end piece 1450 by a short pin 1464. Similarly, lower portions of both first and second gripper arms 1456, 1458 are pivotably connected to distal link bar 1460 by the other long pin 1462. Distal link bar 1460 in turn is pivotably connected to distal end piece 1452 by the other short pin 1464.

30 [000194] At least a portion of tubular core 1454 may be internally threaded for engaging actuation lead screw 1410 (shown in Figures 22A-22F). As actuation lead screw 1410 is turned in an actuation or deployment direction, tubular core 1454 and attached distal end piece 1452 is drawn in a proximal direction. Since proximal end piece 1450 is prevented from also moving in the proximal direction by flexible-to-rigid body portion 1406 (shown in Figures 22A-22F), tubular core 1454 telescopes through proximal end piece 1450 into the central bore of flexible-to-rigid body portion 1406. In other words, when gripper 1408 is deployed, its distal and
35 proximal end pieces 1452, 1450 are moved toward each other, with proximal end piece 1450

sliding along the outside surface of tubular core 1454. As this occurs, first and second gripper arms 1456, 1458 are forced to rotate from a retracted, undeployed position, as shown in Figures 23A-23C, toward an extended, deployed position, as shown in Figures 23D-23F. In the deployed position, the outward tips of gripper arms 1456, 1458 engage with bone tissue within the intramedullary space of the bone to secure gripper 1408 and device 1400 within the bone.

5 [000195] If desired, gripper 1408 may be moved back to the retracted, undeployed state by turning actuation lead screw 1410 (shown in Figures 22A-22F) in an opposite direction, causing tubular core 1454 and attached distal end piece 1452 to move in a distal direction, such that tubular core 1454 recedes from within flexible-to-rigid body portion 1406, distal and proximal end pieces 1452, 1450 separate, and gripper arms 1456, 1458 rotate back to the retracted position shown in Figures 23A-23C.

[000196] According to aspects of the present invention, in some embodiments the tubular core 1454 serves to isolate the threads of the actuation lead screw 1410 from corners and other geometry that could potentially damage the screw. This can improve reliability of the device and reduce or eliminate the chance of particulate matter being dislodged from the device and migrating into the patient. Tubular core 1454 may also serve to protect actuation lead screw 1410 from bending moments generated by the gripper during deployment. This in turn makes the device more robust and enables the screw to provide higher torque and higher tension performance.

20 [000197] Referring to Figures 24-26, another embodiment of a bone fixation device is shown. Device 1500 is similar in construction and operation to the previously described bone fixation devices. Device 1500 includes a proximal gripper 1502, flexible-to-rigid body portion 1504, and distal gripper 1506. As can be seen in the figures, flexible-to-rigid portion 1504 of the elongate body of device 1500 is disposed at a location on the elongate body distal to a first gripper 1502 and proximal to a second gripper 1506.

25 [000198] As best seen in Figure 25, device 1500 includes two separate actuators. The first actuator 1508 is located internally within device 1500 and operates in similar fashion to the actuators of devices previously described herein. First actuator 1508 includes an internally threaded tube 1510 that is driven by a keyed feature at its proximal end. Tube 1510 is coupled to externally threaded rod 1512. When tube 1510 is rotated, rod 1512 is drawn in a proximal direction. Ramped surfaces at the distal end of rod 1512 cause bendable arms of distal gripper 1506 to be outwardly deployed.

30 [000199] The second actuator 1514 of device 1500 comprises an externally threaded compression screw having a central lumen. The compression screw is coupled to internal threads within proximal gripper 1502. In some embodiments, the compression screw outwardly

35

deploys one, two, three, four or more bendable gripper arms by driving the gripper arms distally against ramped surface(s). In other embodiments, the gripper arm(s) do not move axially when deployed. Instead, the compression screw moved axially in a proximal direction. Because the compression screw has a larger diameter in these embodiments than the internal diameter of a portion the proximal gripper, movement of the compression screw urges the gripper arms in an outward direction. Slots 1515 may be provided in the proximal end of device 1500 to resist torque from proximal gripper 1502

[000200] In operation, device 1500, with grippers 1502 and 1506 in a retracted state, may be inserted into the intramedullary space within a bone, such as a clavicle bone 1516 as shown in Figure 26. Once device 1500 is in place inside the bone, the first actuator 1508 may be actuated from the proximal end of device 1500 by inserting a drive tool through the central lumen of the compression screw of the second actuator 1514, engaging the distal end of the drive tool with the keyed end of tube 1510 and turning, in a manner similar to that previously described.

Longitudinal movement of rod 1512 toward the proximal end of device 1500 causes flexible-to-rigid body portion 1504 to foreshorten and assume its rigid state, and causes distal gripper 1506 to outwardly deploy against the bone, such as the medial segment 1518 of the clavicle bone 1516 shown in Figure 26. The drive tool is then removed, and a drive tool having a larger keyed end is inserted into the keyed end of the compression screw to turn the second actuator 1514, causing the bendable arms of proximal gripper 1502 to outwardly deploy against the bone, such as the lateral segment 1520 of the clavicle bone 1516.

[000201] Referring to Figures 27-29, another embodiment of a bone fixation device is shown. Device 1600 is similar in construction and operation to the previously described bone fixation devices. Device 1600 includes a proximal gripper 1602, flexible-to-rigid body portion 1604, and distal gripper 1606. As can be seen in the figures, flexible-to-rigid portion 1604 of the elongate body of device 1600 is disposed at a location on the elongate body distal to a first gripper 1602 and proximal to a second gripper 1606. In this embodiment, the bendable arms of proximal gripper 1602 are spaced 120 degrees apart around the axis of the device.

[000202] Device 1600 includes a curved hub 1608 having a straight section 1610 for holding inner actuation mechanism 1612. In this embodiment, the single actuation mechanism 1612 actuates both grippers 1602 and 1606. Flexible-to-rigid portion 1604 includes an interlocking cut pattern that prevents uncoiling of the body under tension. The body also has an anti-rotation feature built into it. A chamfer 1614 is provided at the proximal end of flexible-to-rigid portion 1604 to cause the bendable arms of proximal gripper 1602 to expand outwardly when body portion 1604 is driven proximally. The distal portion 1615 of curved hub 1608 may be tapered as shown to allow for easier implantation intraoperatively.

[000203] Figure 29 illustrates how device 1600 may be used with an external fixture 1616 to allow screw holes to be formed in hub 1608 or flexible-to-rigid portion 1604 *in vivo*. In some embodiments, device 1600 is devoid of any preformed screw holes before it is installed in the bone. In some embodiments, hub 1608 is made from a biocompatible material such as PEEK to allow the screw holes to be easily formed *in vivo*. A depth gage 1618 may be provided on the screw forming tool 1620 to aid in screw hole formation.

[000204] Referring to Figures 30-31, another embodiment of a bone fixation device is shown. Device 1700 is similar in construction and operation to the previously described bone fixation devices. Device 1700 includes a curved hub 1702 at its proximal end, a flexible-to-rigid body portion 1704, and a single gripper 1706 located at its distal end. As can be seen in the figures, the single actuatable bone engaging gripper 1706 is disposed on the elongate body at a location distal to the flexible-to-rigid portion 1704 of the elongate body of device 1700.

[000205] Referring to Figures 32-35, another embodiment of a bone fixation device is shown. Device 1800 is similar in construction and operation to the previously described bone fixation devices. Device 1800 includes a proximal gripper 1802, flexible-to-rigid body portion 1804, and distal gripper 1806. As can be seen in the figures, flexible-to-rigid portion 1804 of the elongate body of device 1800 is disposed at a location on the elongate body distal to a first gripper 1802 and proximal to a second gripper 1806. In this embodiment, each of the grippers 1802 and 1806 includes four fan-like bendable arms 1810 similar to those previously described.

[000206] Figures 33 and 34 show cross-sections of device 1800, in which the actuator 1812 can be seen. The distal end of actuator rod 1812 is provided with a cam surface 1814 for outwardly deploying bendable arms 1810 of distal gripper 1806 from the retracted position shown in Figure 33 to the deployed position shown in Figure 34. Figure 35 shows device 1800 implanted in clavicle bone 1816 across fracture 1818. One or more screws 1820 may be used to secure the proximal end of device 1800, as previously described.

[000207] Referring to Figures 36-39, another embodiment of a bone fixation device is shown. Device 1900 is similar in construction and operation to the previously described bone fixation devices. Device 1900 includes a straight hub 1902 at its proximal end, flexible-to-rigid body portion 1904, and distal gripper 1906. As can be seen in the figures, the single actuatable bone engaging gripper 1906 is disposed on the elongate body at a location distal to the flexible-to-rigid portion 1904 of the elongate body of device 1900. In this embodiment, single gripper 1906 includes four fan-like bendable arms 1910 similar to those previously described.

[000208] Figures 37 and 38 show cross-sections of device 1900, in which the actuator 1912 can be seen. The distal end of actuator rod 1912 is provided with a cam surface 1914 for outwardly deploying bendable arms 1910 of distal gripper 1906 from the retracted position shown in Figure

37 to the deployed position shown in Figure 38. Figure 39 shows device 1900 implanted in clavicle bone 1916 across fracture 1918. One or more screws 1920 may be used to secure the proximal end of device 1900, as previously described.

5 [000209] Referring to Figures 40 and 41, another embodiment of a flexible-to-rigid body portion 2000 is shown. Figure 40 shows a perspective view of body portion 2000 having a spiral cut formed through its tube wall. Figure 41 shows a plan view of the cut pattern laid flat. Under axial compression, the extensions formed by the spiral cut collide, aiding in the rigidity of the construct.

10 [000210] Referring to Figures 42 and 43A, another embodiment of a flexible-to-rigid body portion 2100 is shown. Figure 42 shows a perspective view of body portion 2100 having a spiral cut formed through its tube wall. Figure 43A shows a plan view of the cut pattern laid flat. Axial compression causes the proximally and distally extending features to translate transverse to the longitudinal axis of the body portion 2100. This lateral movement causes keying features formed on the extending features to interengage, aiding in the rigidity of the construct.

15 [000211] Referring to Figure 43B, another embodiment of a flexible-to-rigid body portion 2102 is shown in plan view, with the cut pattern laid flat. Like the pattern shown in Figure 43A, axial compression causes the proximally and distally extending features to translate transverse to the longitudinal axis of the body portion 2102. This lateral movement causes keying features formed on the extending features to interengage, aiding in the rigidity of the construct.

20 [000212] Referring to Figures 44 and 45, another embodiment of a flexible-to-rigid body portion 2200 is shown. Figure 44 shows a perspective view of body portion 2200 having a spiral cut formed through its tube wall. Figure 45 shows a plan view of the cut pattern laid flat. The interlocking features of the spiral cut are transverse to the longitudinal axis of the body portion 2200. This maximizes contact surface in compression to aid in rigidity. The gap between the
25 arms may be varied as shown to increase flexibility in one plane.

[000213] Referring to Figures 46 and 47, another embodiment of a flexible-to-rigid body portion 2300 is shown. Figure 46 shows a perspective view of body portion 2300 having a spiral cut formed through its tube wall. Figure 47 shows a plan view of the cut pattern laid flat. The features of the spiral cut step horizontally, transverse to the longitudinal axis of the body portion
30 2200. This maximizes contact surface in compression. Varying gaps allow the body to twist more.

[000214] Referring to Figures 48 and 49, another embodiment of a flexible-to-rigid body portion 2400 is shown. Figure 48 shows a perspective view of body portion 2400 having a spiral cut formed through its tube wall. Figure 49 shows a plan view of the cut pattern laid flat. The
35 pattern of the spiral cut includes a sinusoidal wave interrupted by locking features. The gap

formed by the cut can be varied longitudinally. For example, the gap at locations 2402, 2404 and 2406 can get progressively smaller as shown. When body portion 2400 is axially compressed, it forms a curve in each segment in which the gap is varied. The resulting shape is a curve which spirals down the length of the body, similar to the shape of a cork screw. In some
5 embodiments, this shape aids the device in being able to grip the interior surfaces of the bone.

[000215] While exemplary embodiments of the present invention have been shown and described herein, it will be obvious to those skilled in the art that such embodiments are provided by way of example only. Numerous variations, changes, and substitutions will now occur to those skilled in the art without departing from the invention. It should be understood that various
10 alternatives to the embodiments of the invention described herein may be employed in practicing the invention. To the extent that any information that has been incorporated herein by reference conflicts with information in this application, the information in the present application takes precedent.

15

WHAT IS CLAIMED IS:

1. A bone fixation device comprising:
an elongate body having a longitudinal axis and having a first state in which at least a
5 portion of the body is flexible and a second state in which the body is generally rigid;
a first actuatable bone engaging gripper disposed on the elongate body;
a second actuatable bone engaging gripper disposed on the elongate body distal from the
first gripper; and
an actuator operably connected to at least one of the first and the second grippers to
10 actuate the gripper from a disengaged configuration to an engaged configuration, the first and the
second grippers each having at least one bendable member, the member pivoting away from the
longitudinal axis of the elongate body when the gripper is actuated, the actuator also being
operably connected to the elongate body to change the elongate body from its flexible state to its
rigid state.
15
2. The bone fixation device of claim 1, further comprising a hub coupled to a proximal end
of the elongate body, and wherein the flexible-to-rigid portion of the elongate body is disposed at
a location on the elongate body distal to the first gripper and proximal to the second gripper.
- 20 3. The bone fixation device of claim 2 wherein the hub is straight.
4. The bone fixation device of claim 2 wherein the hub is curved.
5. A surgical kit comprising:
25 the bone fixation device of claim 2; and
an alignment tool configured to couple to the hub, the tool further configured to align
with a portion of the device to form at least one screw hole into the portion of the device.
6. The surgical kit of claim 5 wherein the alignment tool is configured to align with at least
30 the hub of the device to form a screw hole in the hub.
7. The surgical kit of claim 5 wherein the alignment tool is configured to align with at least
the flexible-to-rigid portion of the device to form a screw hole in that portion.

8. The bone fixation device of claim 1, further comprising a hub coupled to a proximal end of the elongate body, and wherein the flexible-to-rigid portion of the elongate body is disposed at a location on the elongate body distal to both the first and the second grippers.
- 5 9. The bone fixation device of claim 8 wherein the hub is straight.
10. The bone fixation device of claim 8 wherein the hub is curved.
11. A surgical kit comprising:
10 the bone fixation device of claim 8; and
an alignment tool configured to couple to the hub, the tool further configured to align with a portion of the device to form at least one screw hole into the portion of the device.
12. The surgical kit of claim 11 wherein the alignment tool is configured to align with at least
15 the hub of the device to form a screw hole in the hub.
13. The surgical kit of claim 11 wherein the alignment tool is configured to align with at least the flexible-to-rigid portion of the device to form a screw hole in that portion.
- 20 14. A bone fixation device comprising:
an elongate body having a longitudinal axis and having a first state in which at least a portion of the body is flexible and a second state in which the body is generally rigid;
a single actuatable bone engaging gripper disposed on the elongate body at a location
25 distal to the flexible-to-rigid portion of the elongate body, the gripper having at least one bendable member, the member pivoting away from the longitudinal axis of the elongate body when the gripper is actuated; and
an actuator operably connected to the gripper to actuate the gripper from a disengaged configuration to an engaged configuration, the actuator also being operably connected to the elongate body to change the elongate body from its flexible state to its rigid state.
- 30 15. The bone fixation device of claim 14, further comprising a hub coupled to a proximal end of the elongate body, and wherein the flexible-to-rigid portion of the elongate body is disposed at a location on the elongate body proximal to the first gripper.
- 35 16. The bone fixation device of claim 15 wherein the hub is straight.

17. The bone fixation device of claim 15 wherein the hub is curved.
18. A surgical kit comprising:
5 the bone fixation device of claim 15; and
an alignment tool configured to couple to the hub, the tool further configured to align
with a portion of the device to form at least one screw hole into the portion of the device.
19. The surgical kit of claim 18 wherein the alignment tool is configured to align with at least
10 the hub of the device to form a screw hole in the hub.
20. The surgical kit of claim 18 wherein the alignment tool is configured to align with at least
the flexible-to-rigid portion of the device to form a screw hole in that portion.
- 15 21. A bone fixation device comprising:
a generally tubular body having a circumferential surface, an inner lumen, and a wall
extending therebetween, the body being sized to fit within an intramedullary space within a
bone, the body having a longitudinal axis;
a helical slit through the body wall extending around the circumferential surface and
20 axially along at least a portion of the body; and
a compression mechanism configured to apply an axial compression to the body to move
the slit towards a closed position, thereby transforming the body from a generally flexible state
to a generally rigid state,
wherein the helical slit forms multiple pairs of mating features, each pair having a
25 proximally projecting member and a distally projecting member, the proximally projecting
member having a ramped surface on its proximally facing end of sufficient angle to cause the
proximally projecting member to move in a first generally transverse direction when under axial
compression, the distally projecting member having a ramped surface on its distally facing end
of sufficient angle to cause the distally projecting member to move in a second generally
30 transverse direction generally opposite the first direction when under axial compression such that
the projecting members of a pair move toward each other when under axial compression.
22. The bone fixation device of claim 21 wherein at least one of the projecting members of a
pair comprises a laterally projecting keying feature that interengage with a keying feature of the
35 opposite member of the pair when the members of the pair move toward each other.

23. The bone fixation device of claim 21 wherein at least one of the projecting members of a pair comprises a plurality of laterally projecting keying features that interengage with keying features of the opposite member of the pair when the members of the pair move toward each other.

5

24. The bone fixation device of claim 21 wherein each of the projecting members of a pair has a plurality of laterally projecting keying features that interengage with the keying features of the opposite member of the pair when the members of the pair move toward each other.

10

25. The bone fixation device of claim 23 wherein at least one of the plurality of laterally projecting keying features is nested on another of the laterally projecting keying features.

26. The bone fixation device of claim 21 further comprising at least two pairs of mating features located within one revolution of the helical slit.

15

27. The bone fixation device of claim 21 further comprising at least five pairs of mating features located within one revolution of the helical slit.

28. The bone fixation device of claim 2 wherein the actuator is operably connected to both the first and the second grippers to actuate both grippers from a disengaged configuration to an engaged configuration.

20

29. The bone fixation device of claim 2 further comprising a second actuator, thereby allowing each of the two grippers to be independently actuated.

25

30

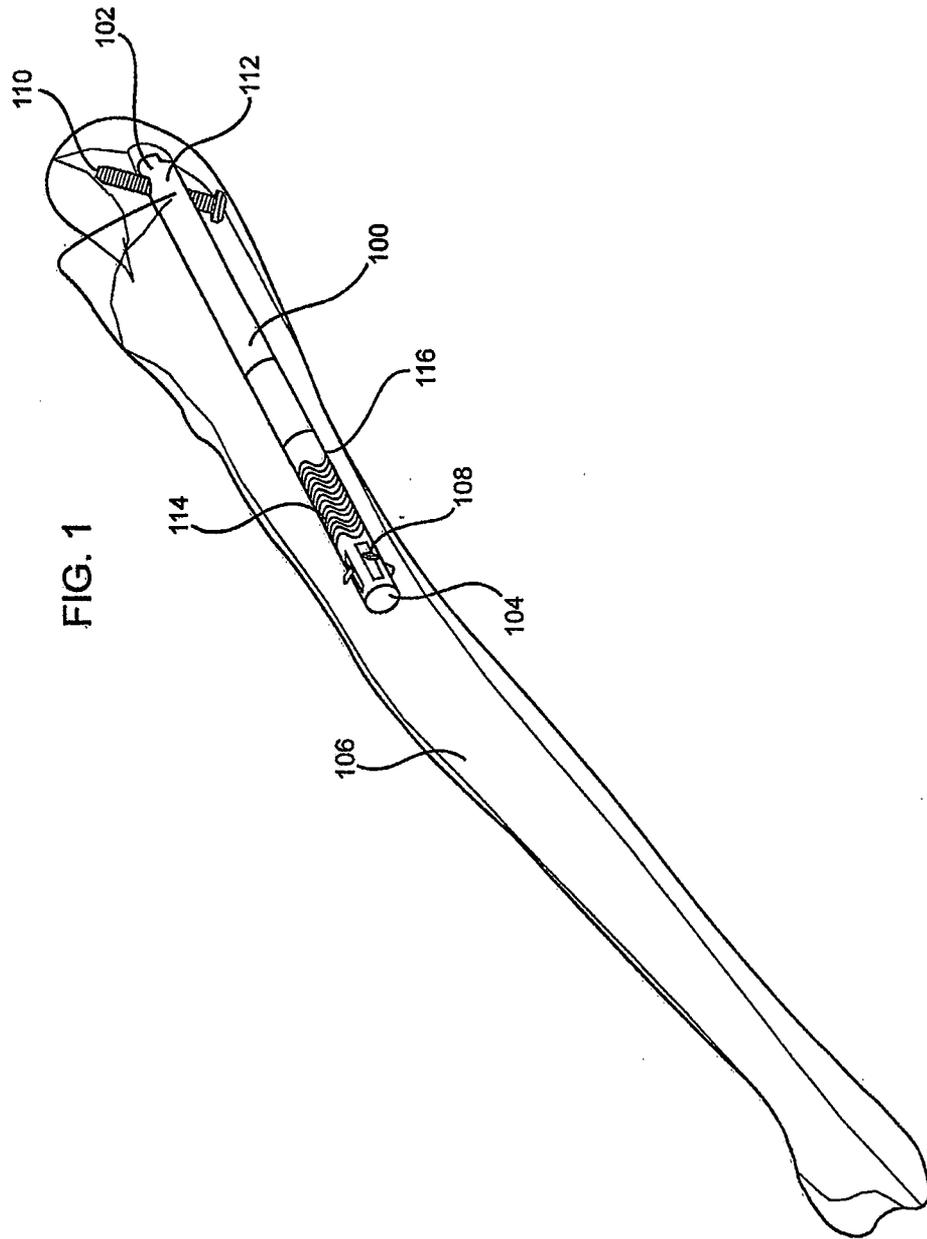

FIG. 2

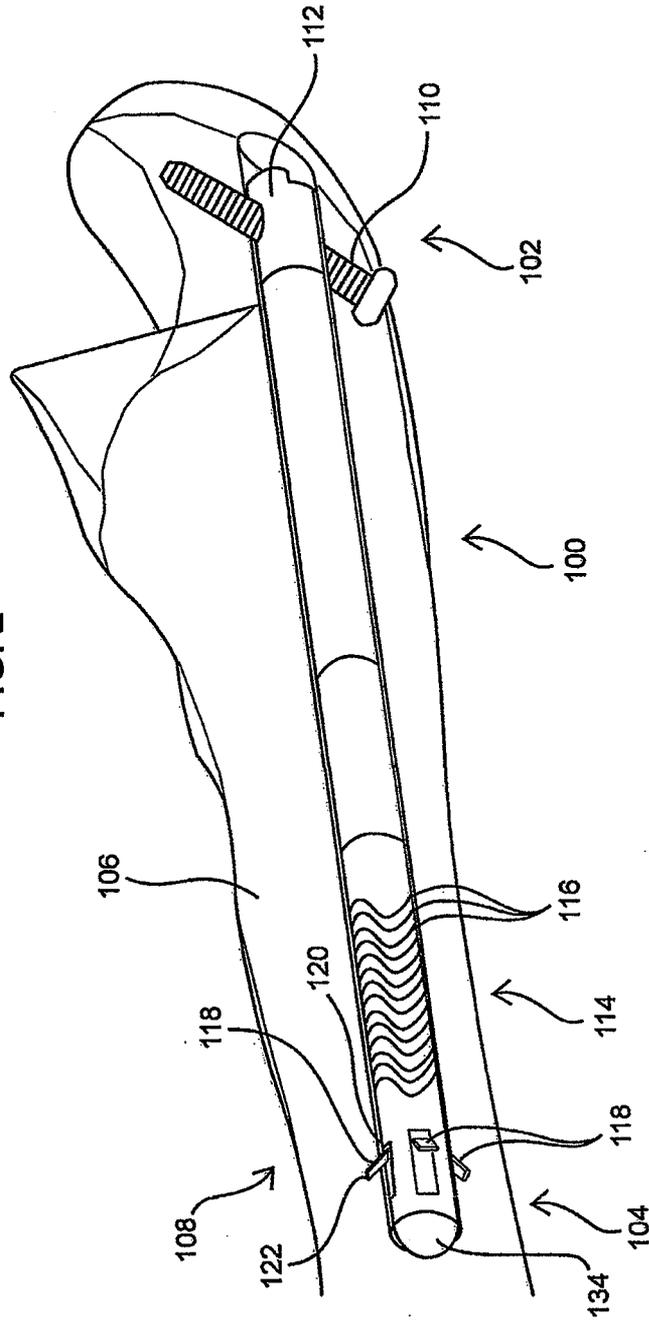
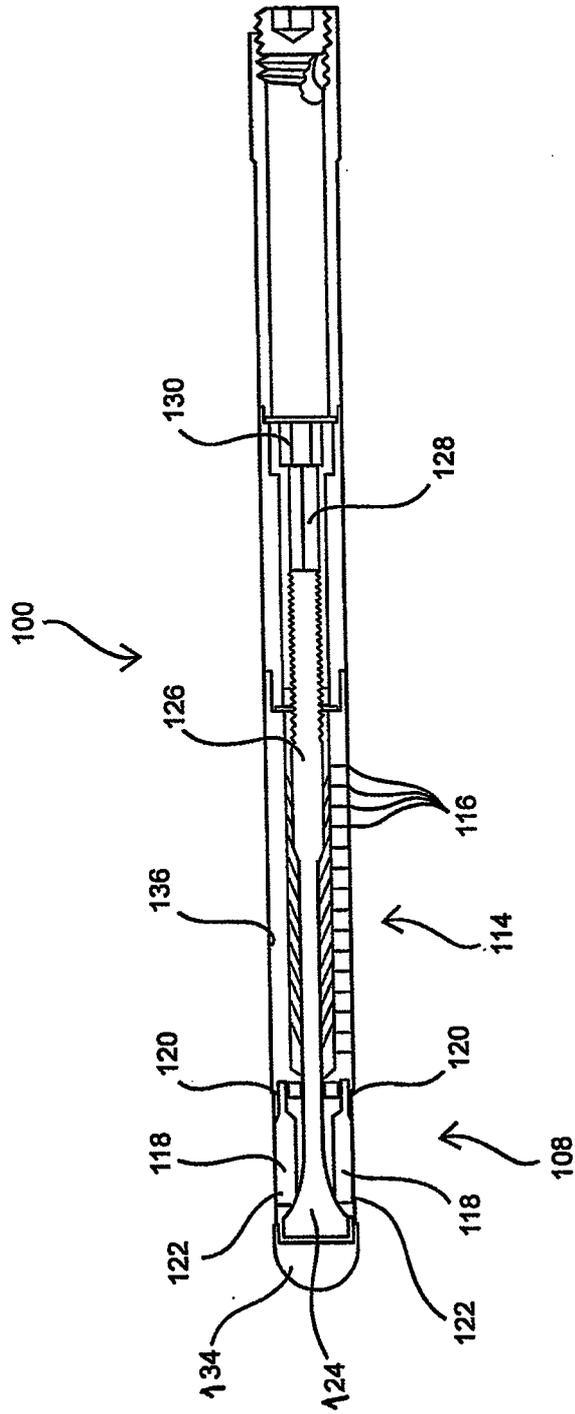

FIG. 3



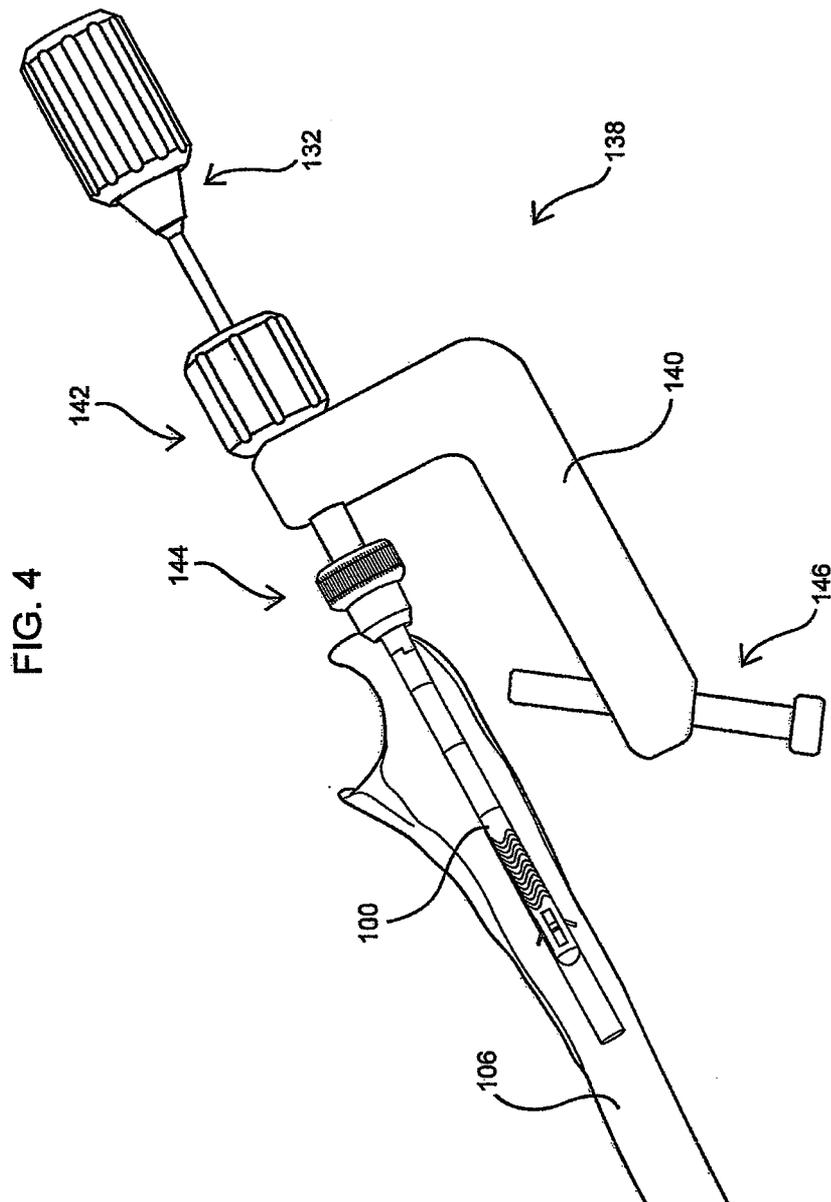
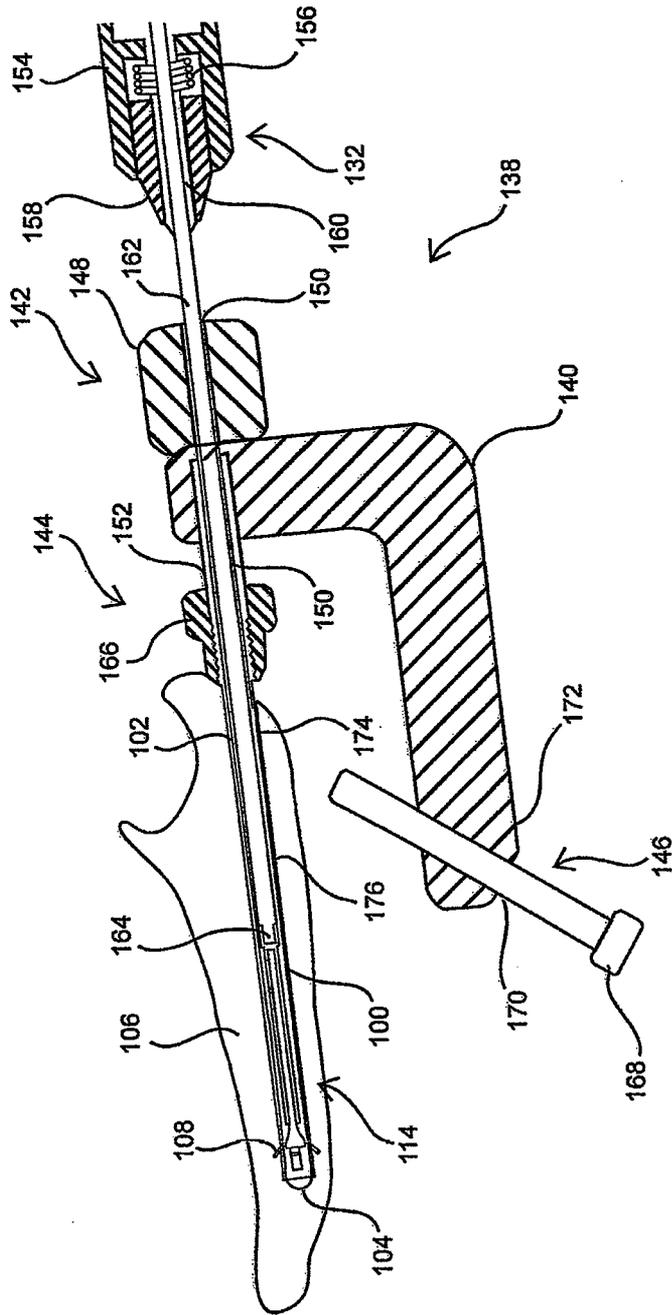

FIG. 5



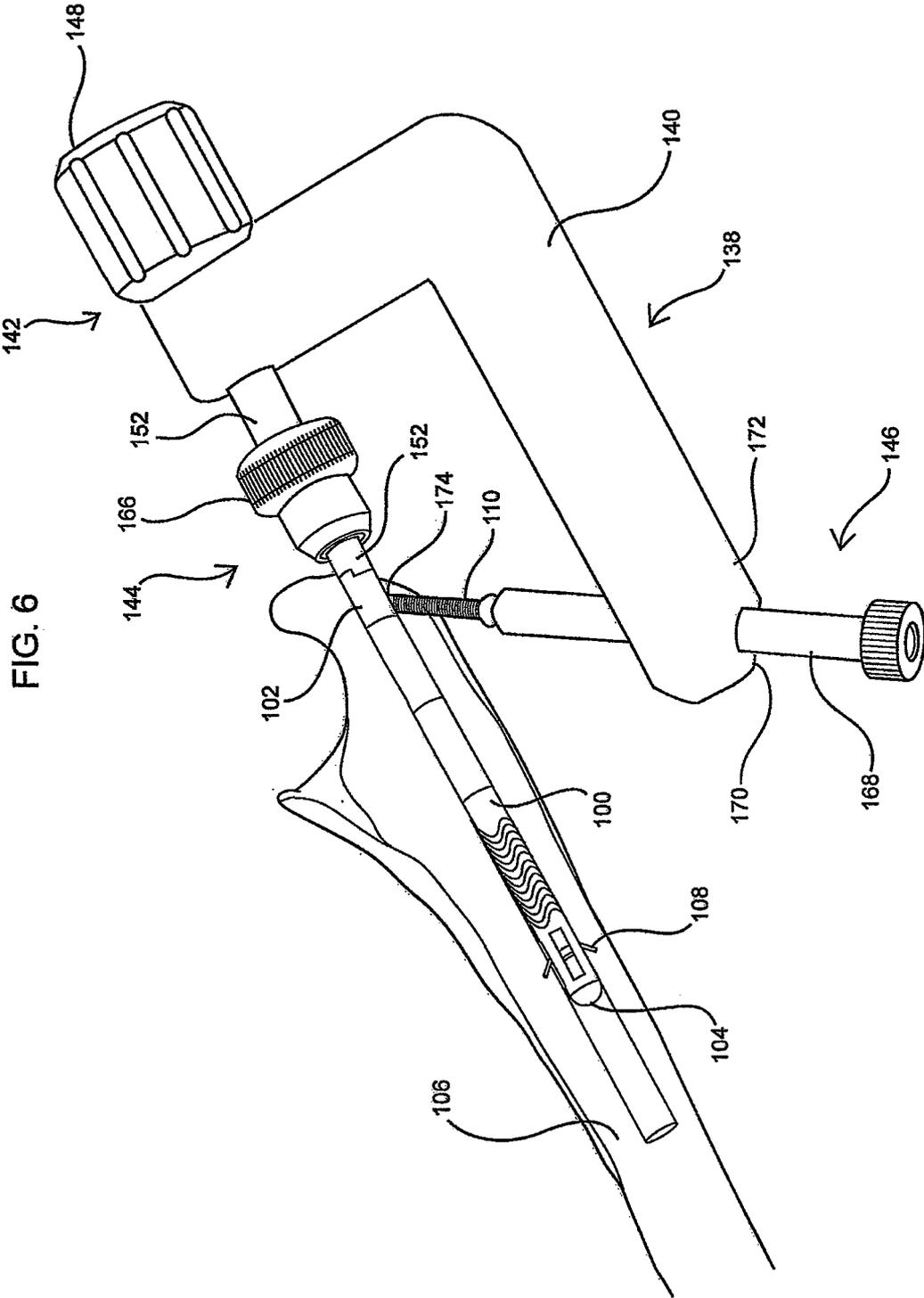
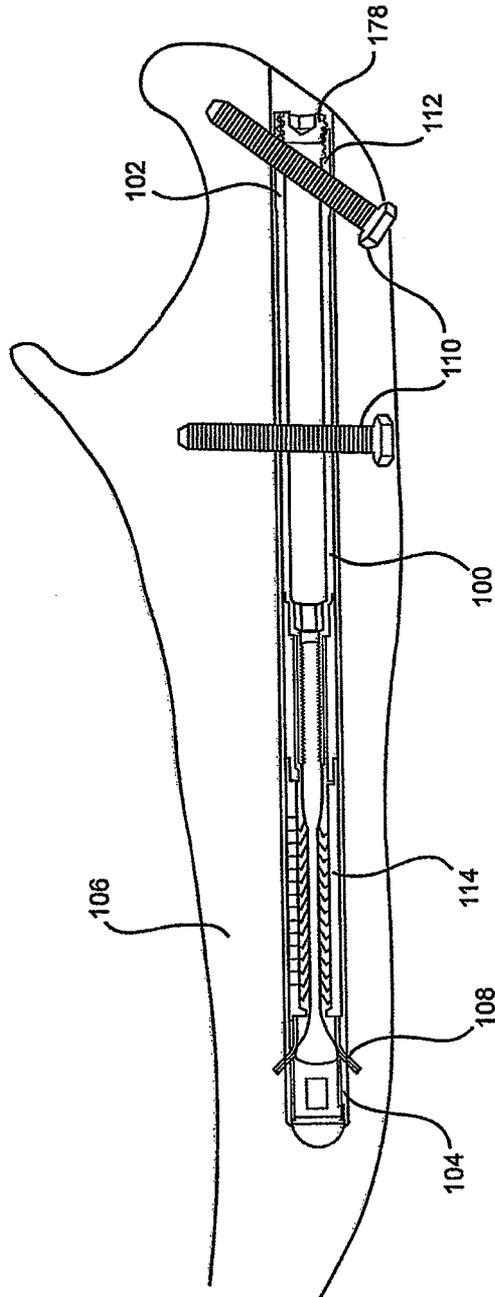

FIG. 7



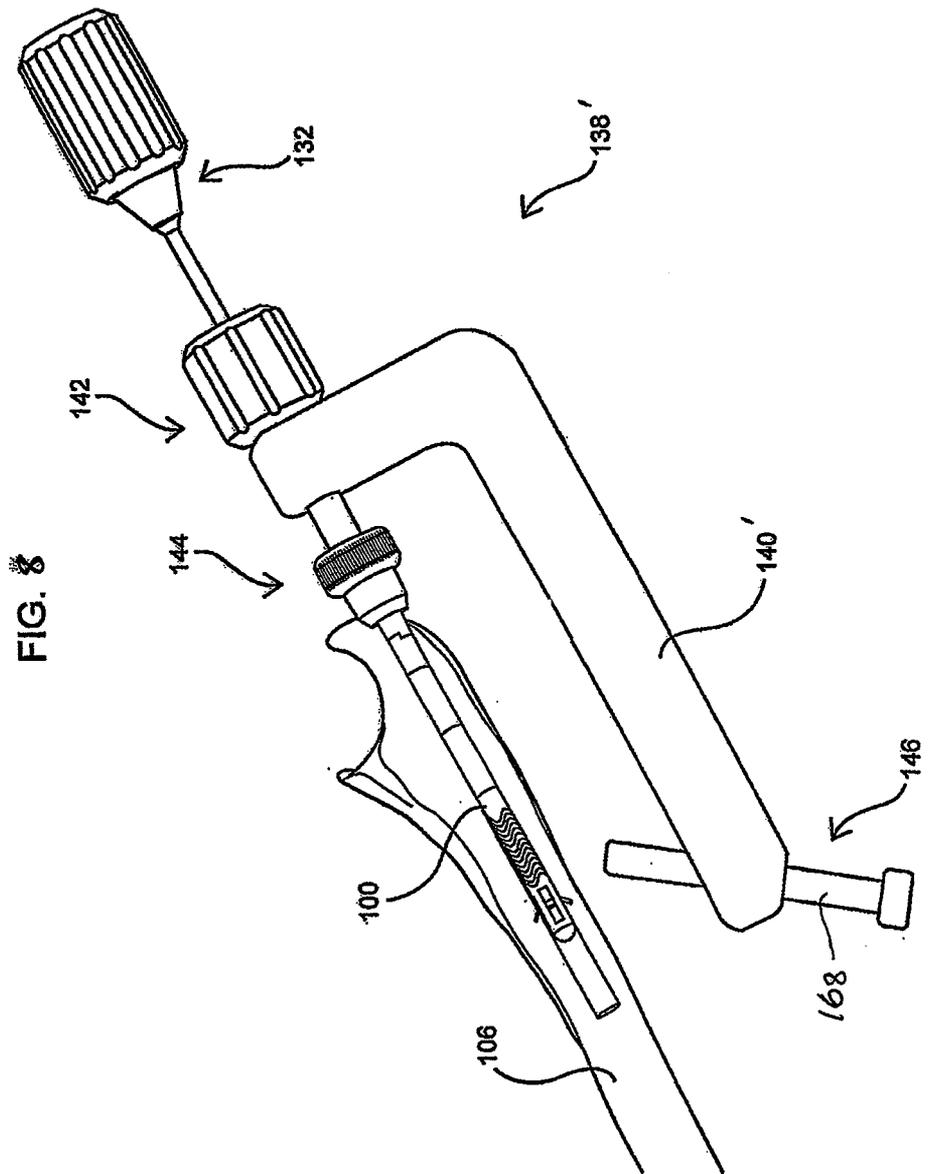

FIG. 9A

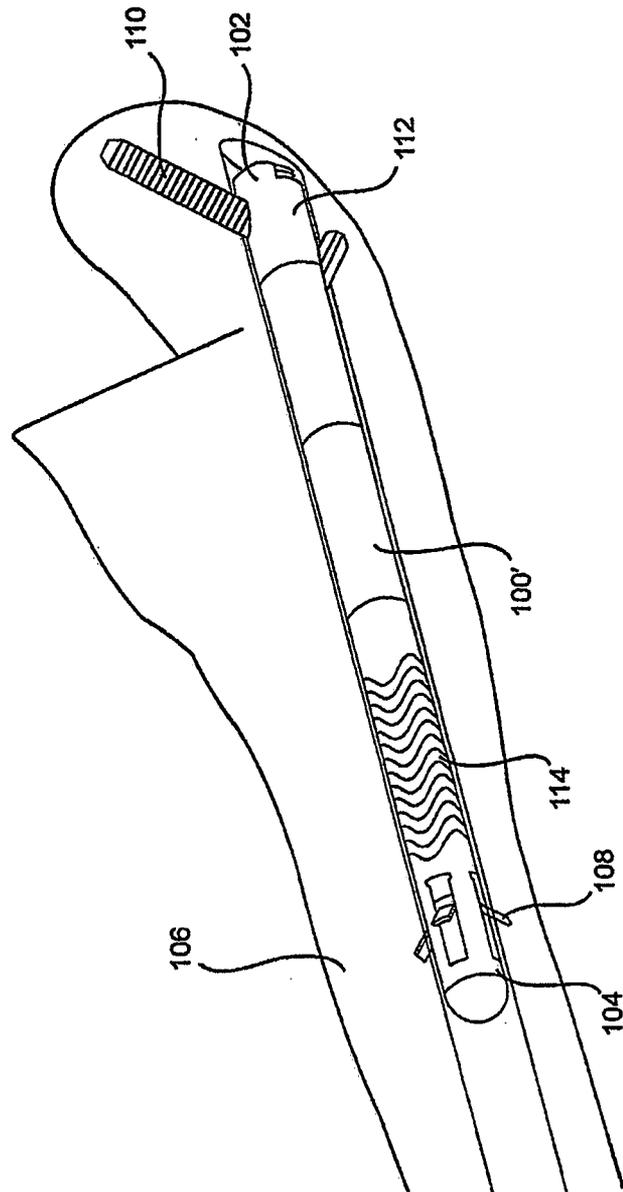
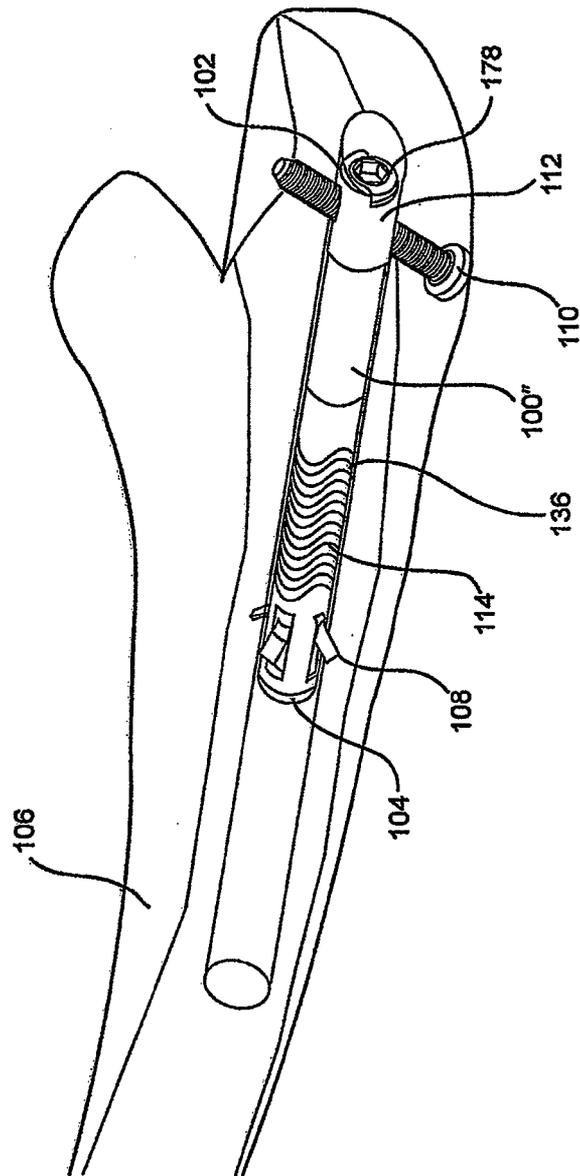

FIG. 9B



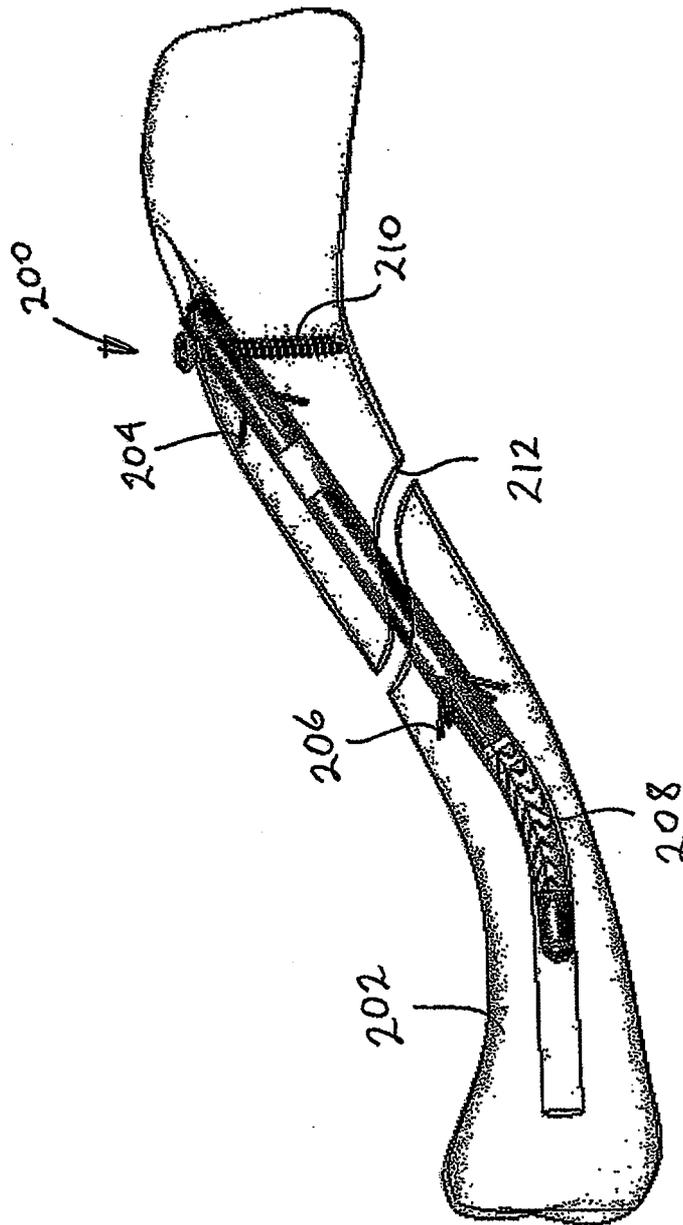

FIG. 10A

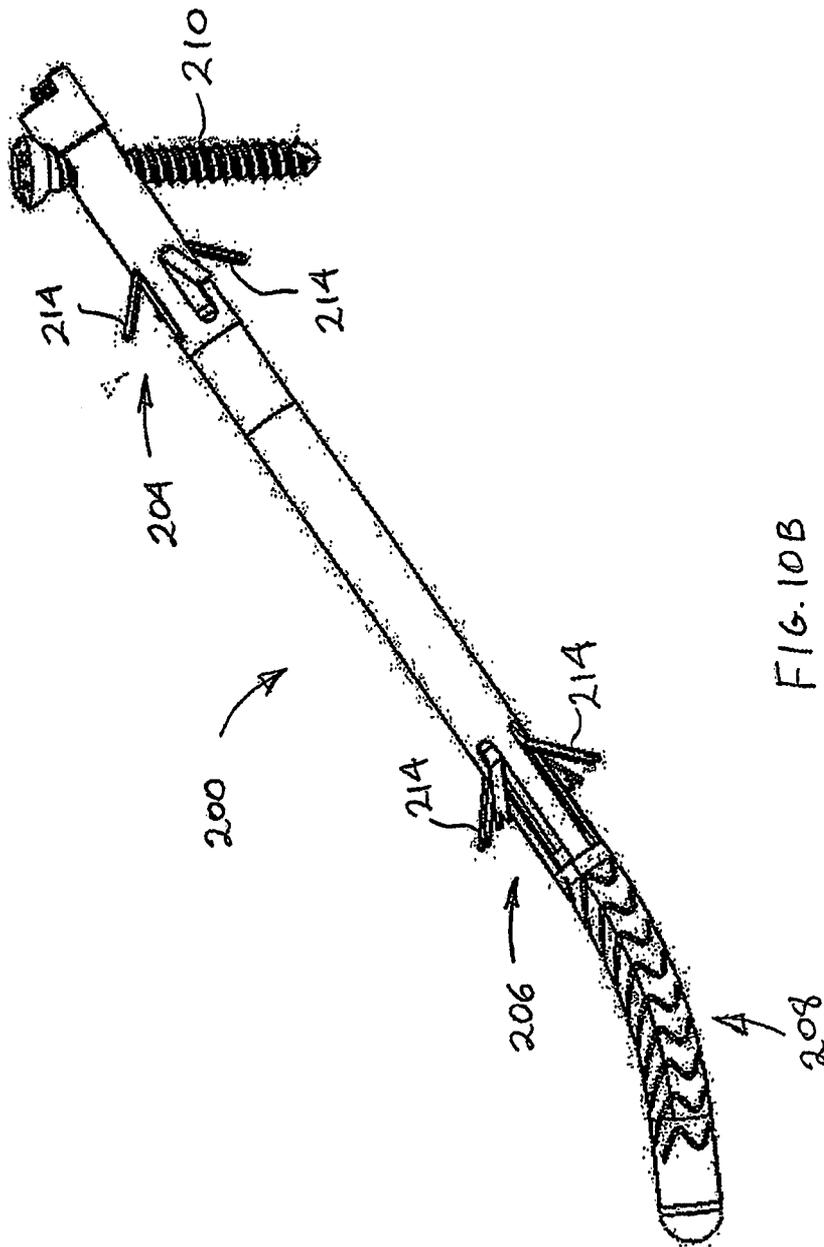

FIG. 10B

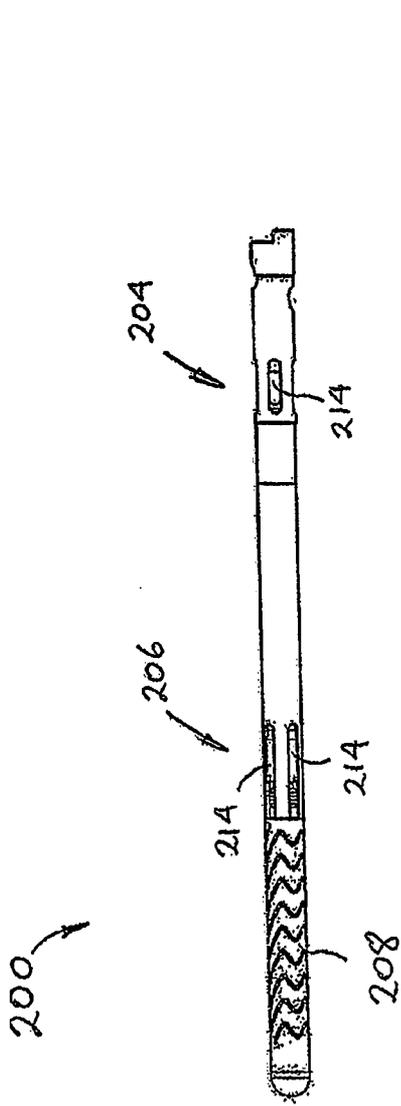

FIG. 10C

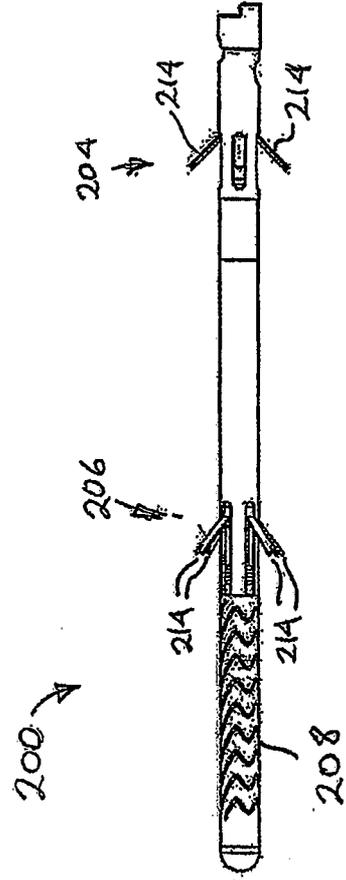

FIG. 10D

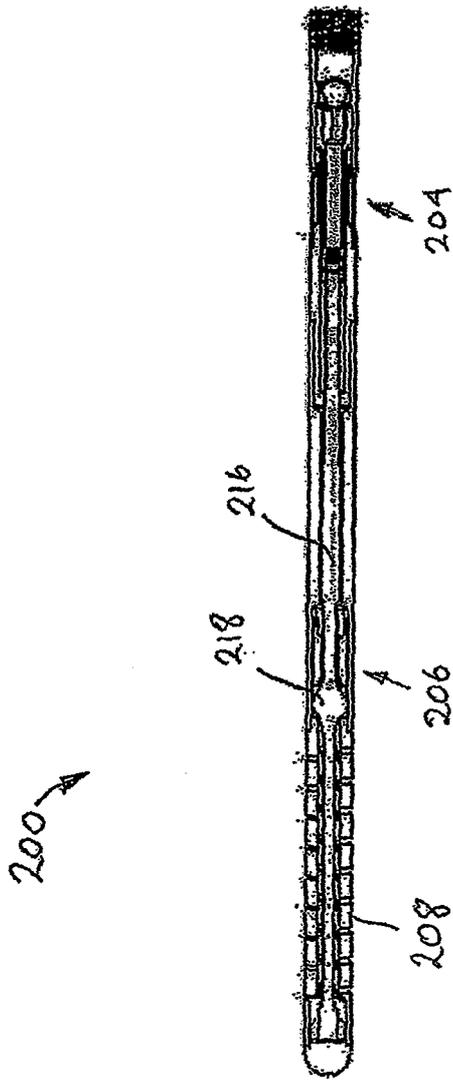

FIG. 10E

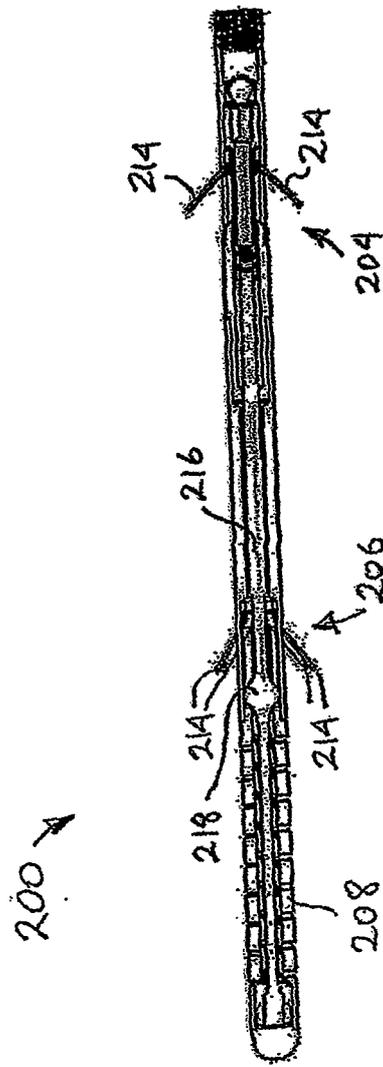

FIG. 10F

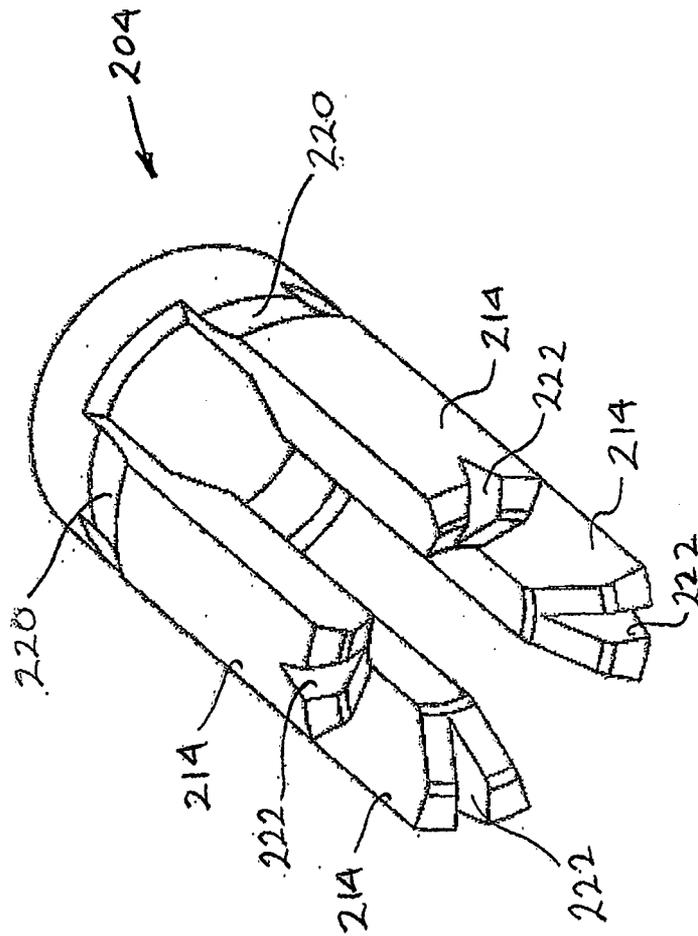

FIG. 10G

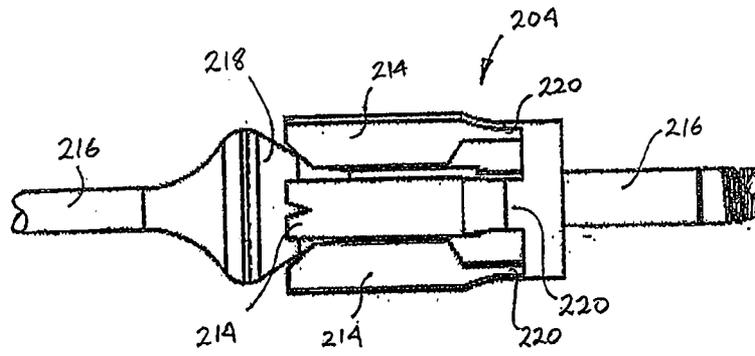

FIG. 10H

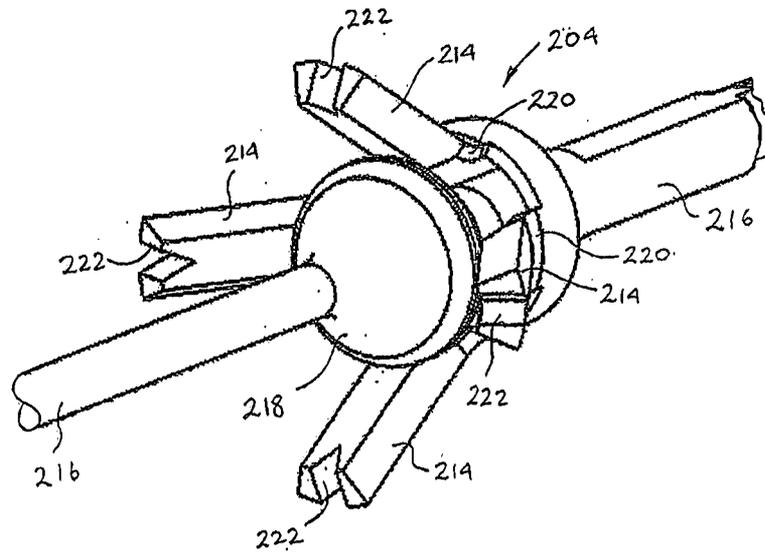
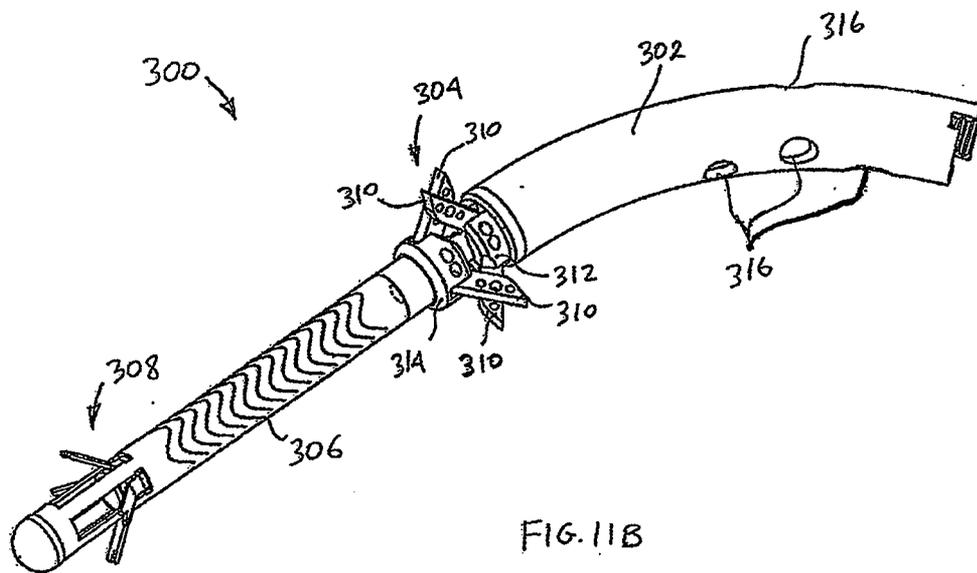
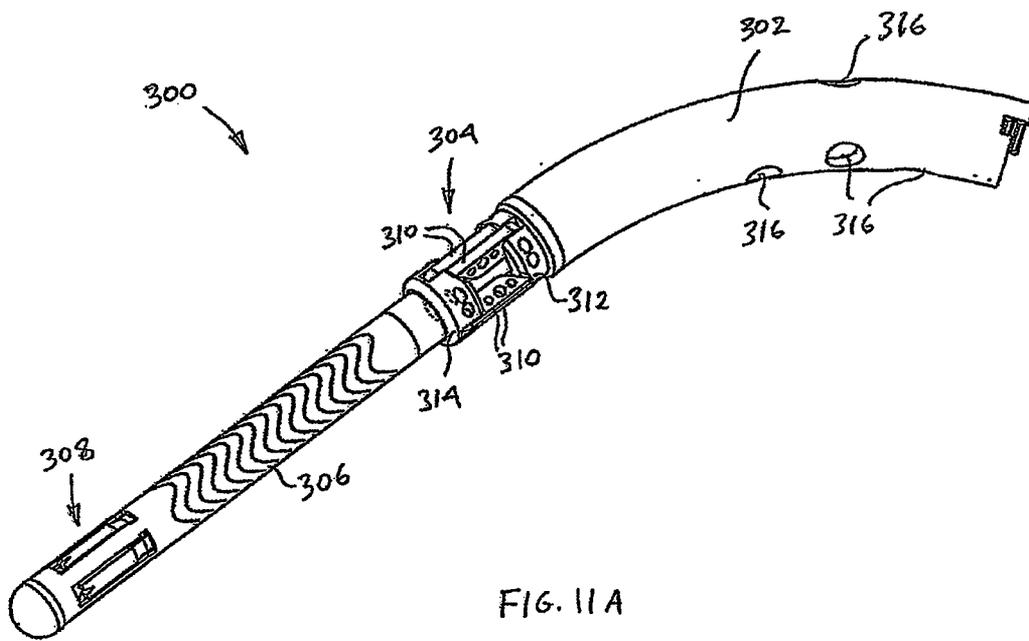
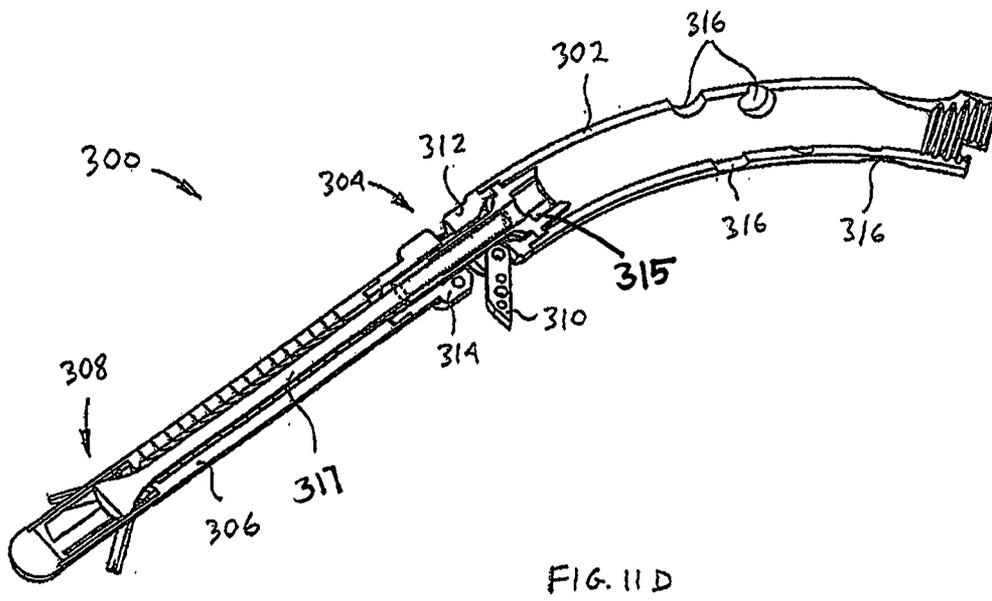
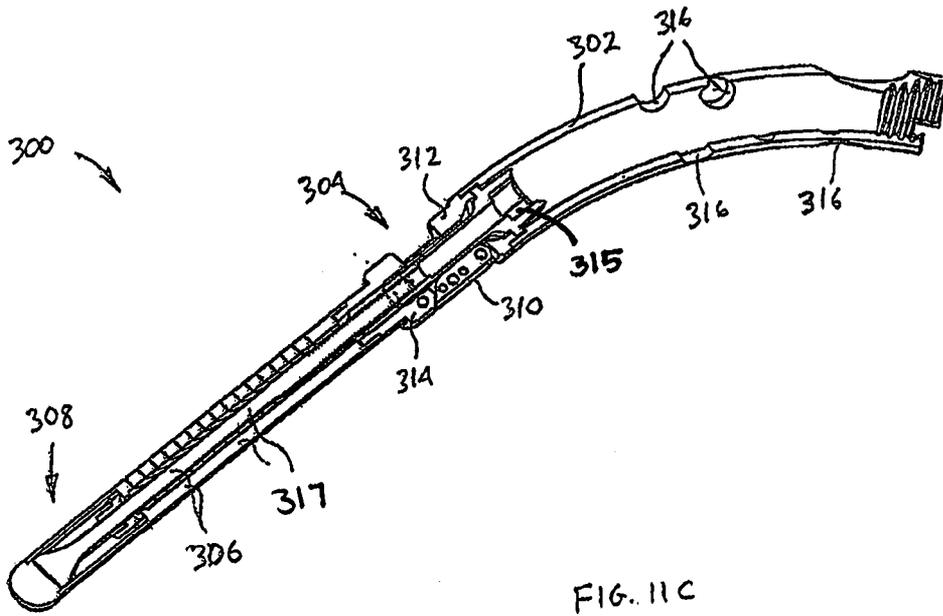

FIG. 10I





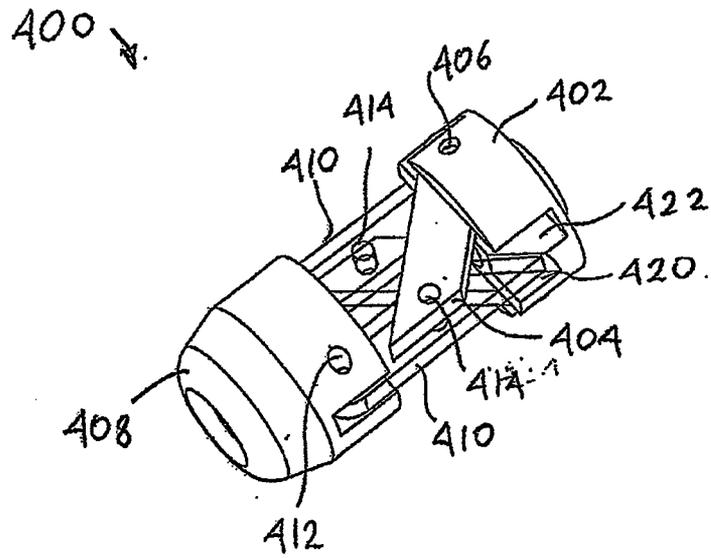

FIG. 12A

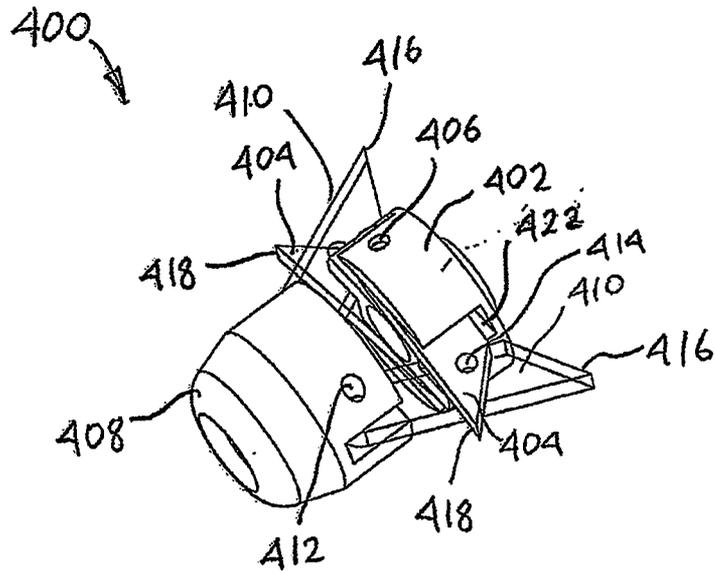

FIG. 12B

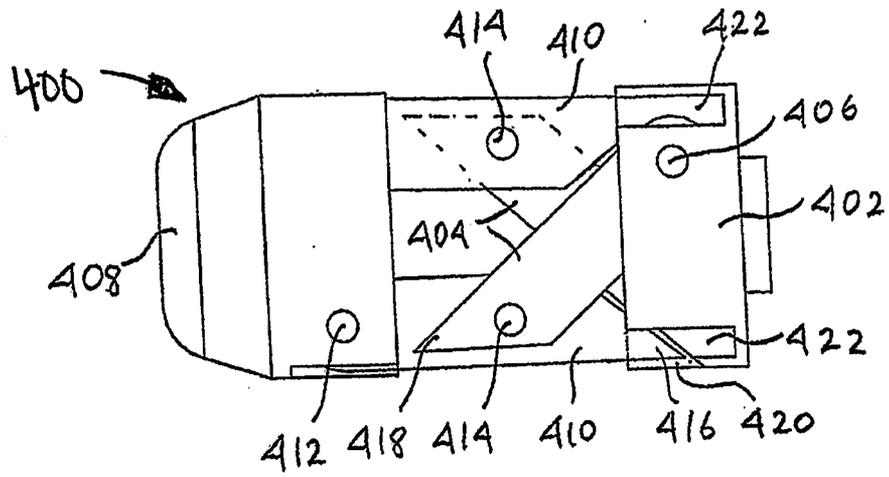

FIG. 12C

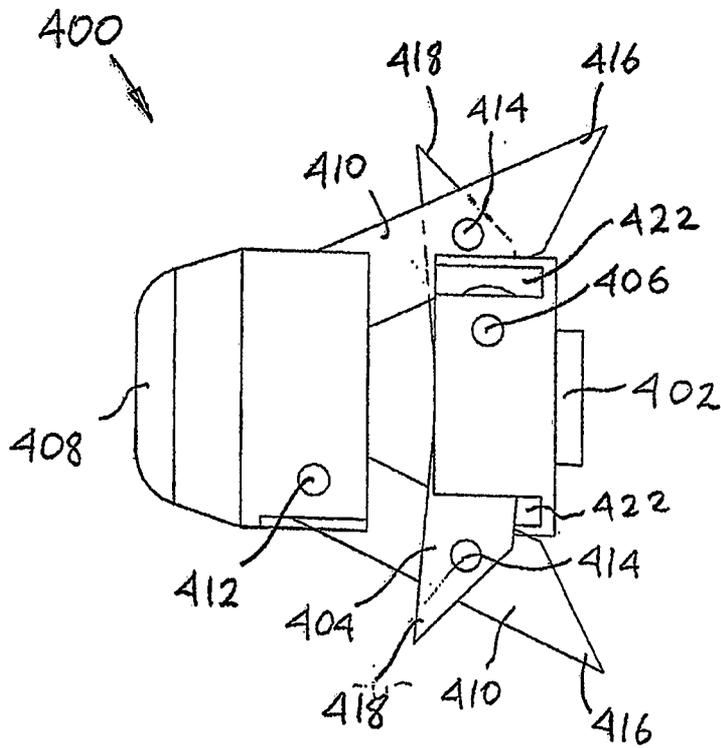

FIG. 12D

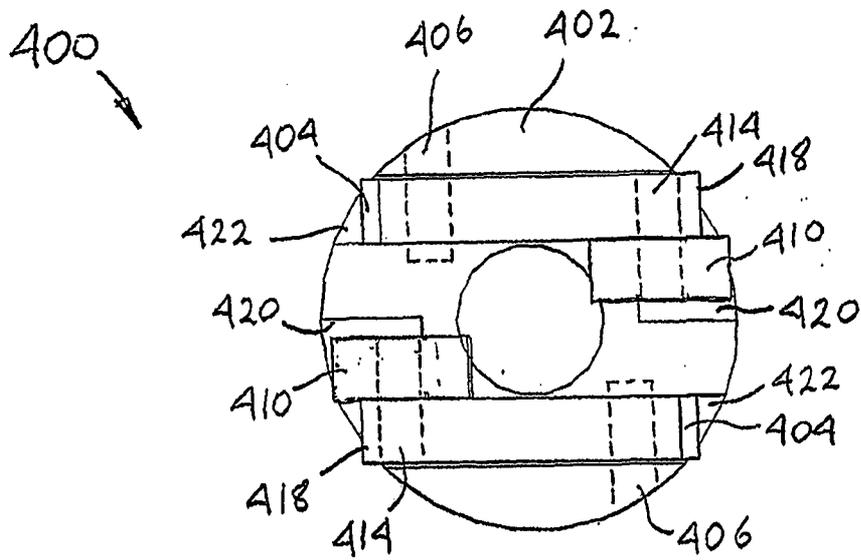

FIG. 12 E

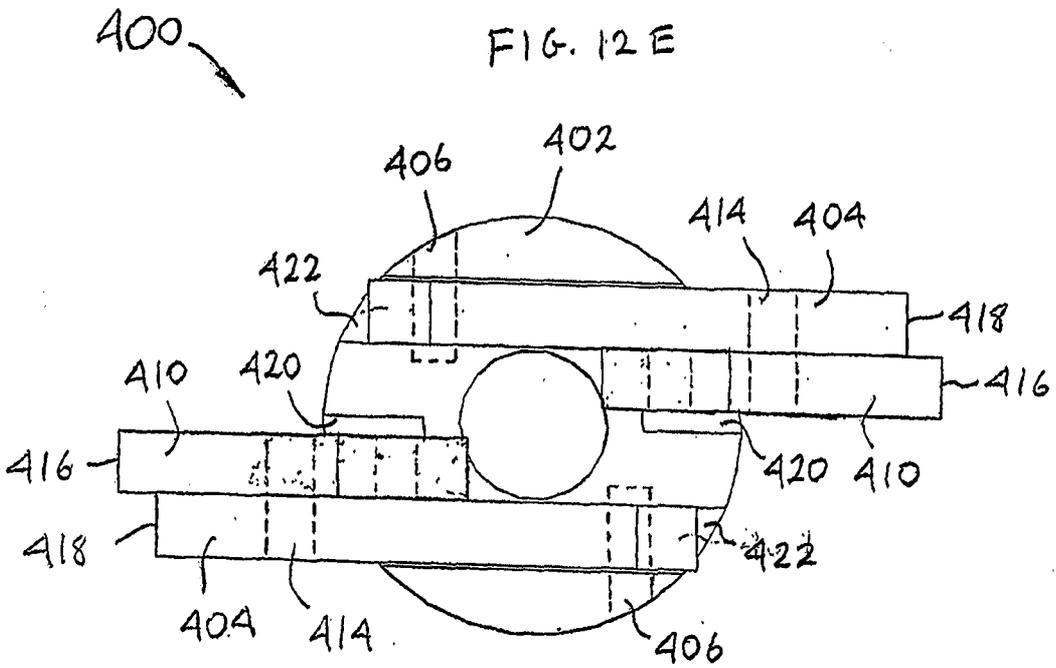

FIG. 12 F

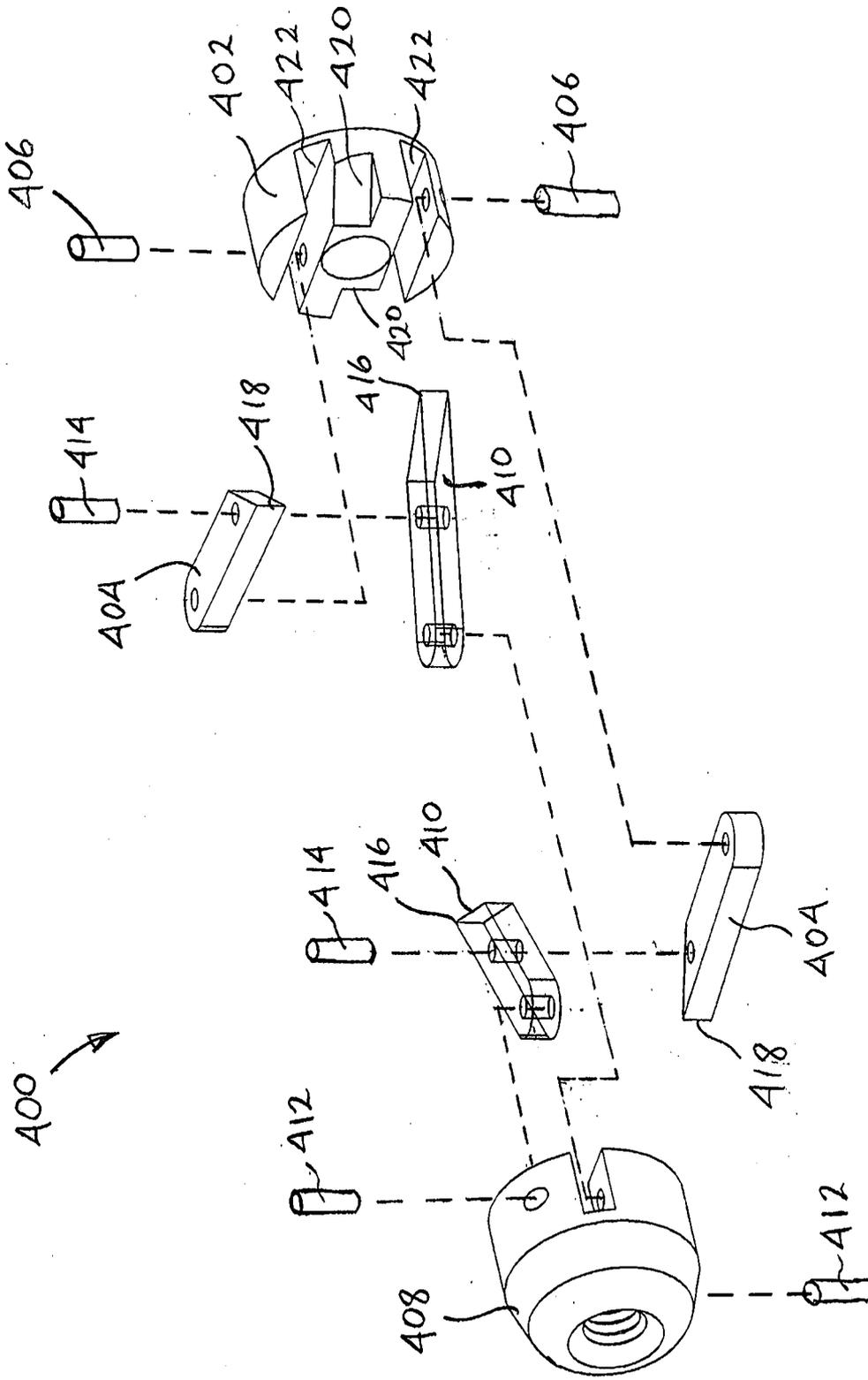

FIG. 12 G

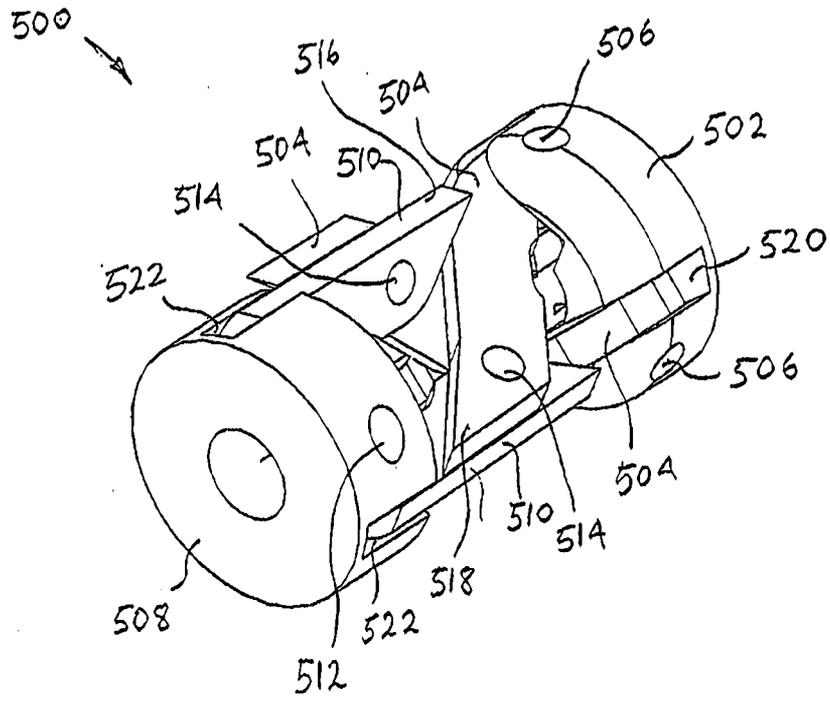

FIG. 13A

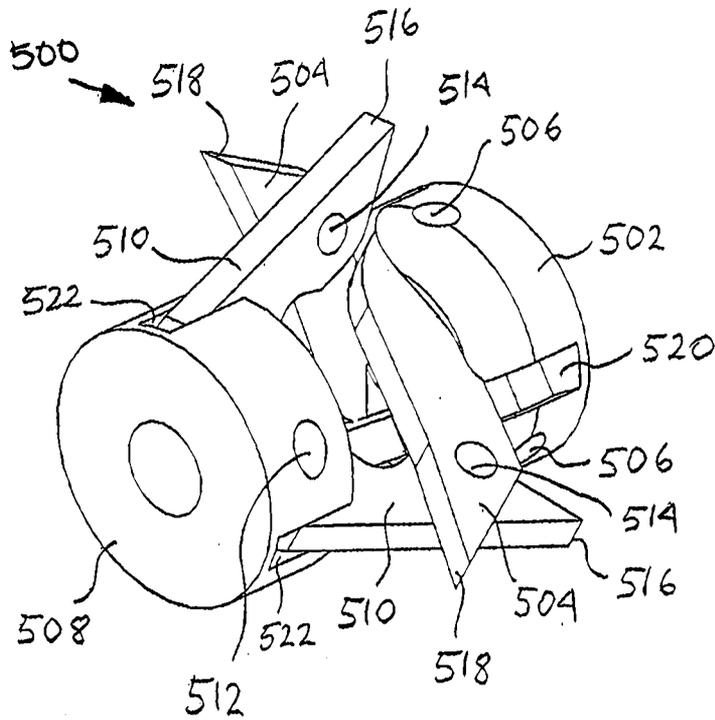

FIG. 13B

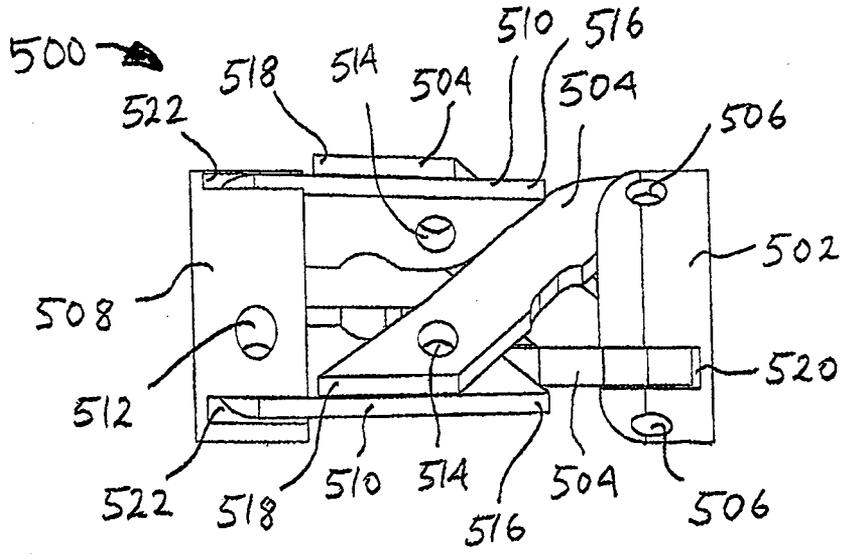

FIG. 13C

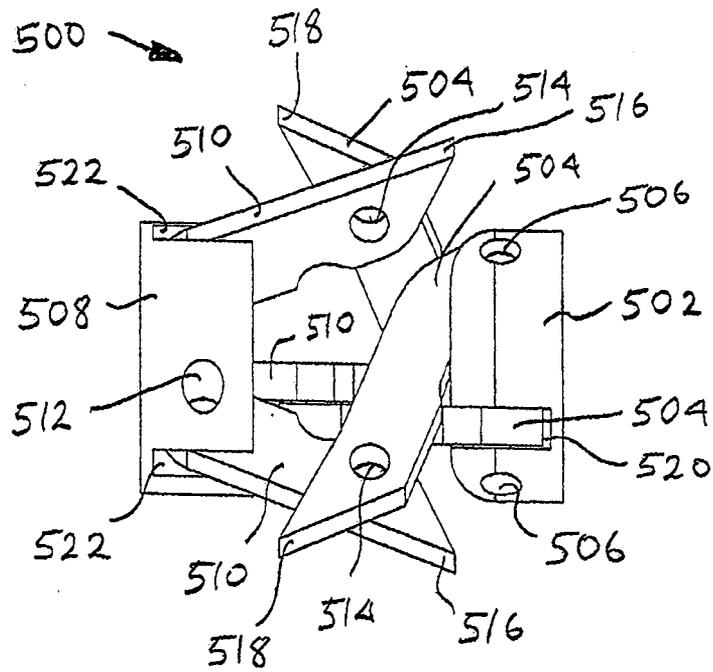

FIG. 13D

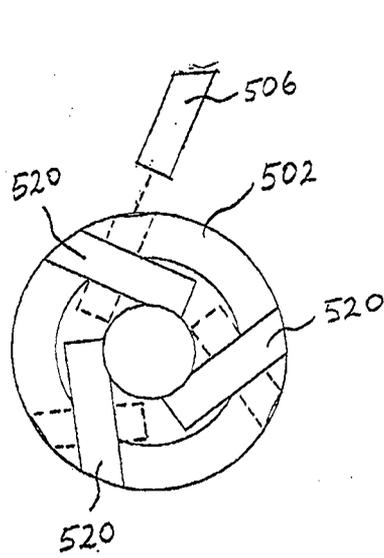

FIG. 13E

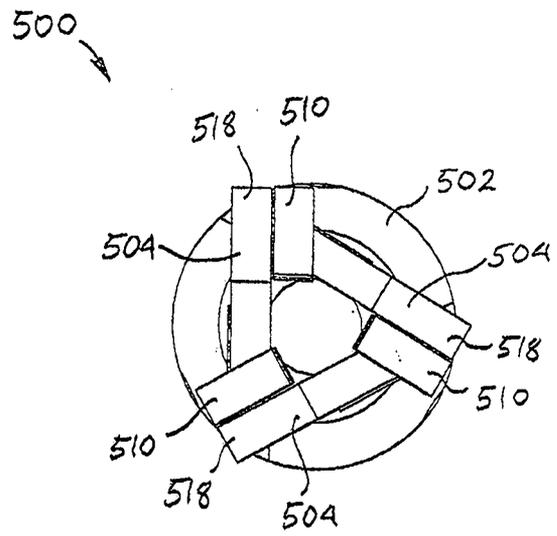

FIG. 13F

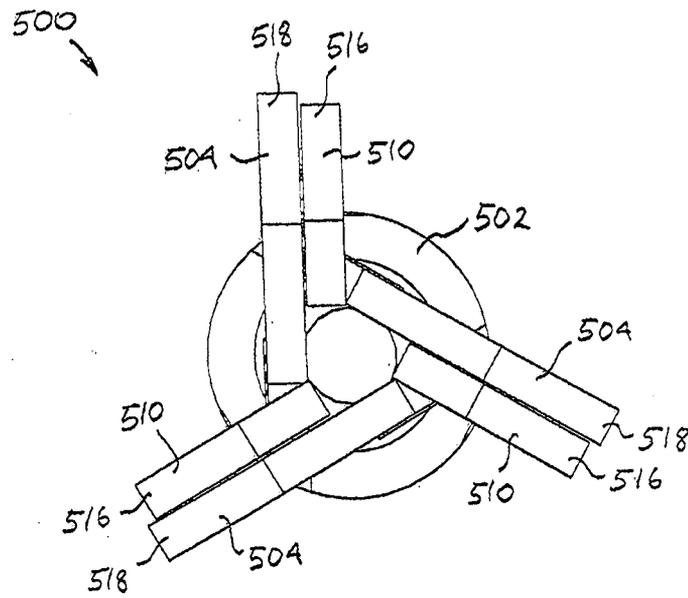

FIG. 13G

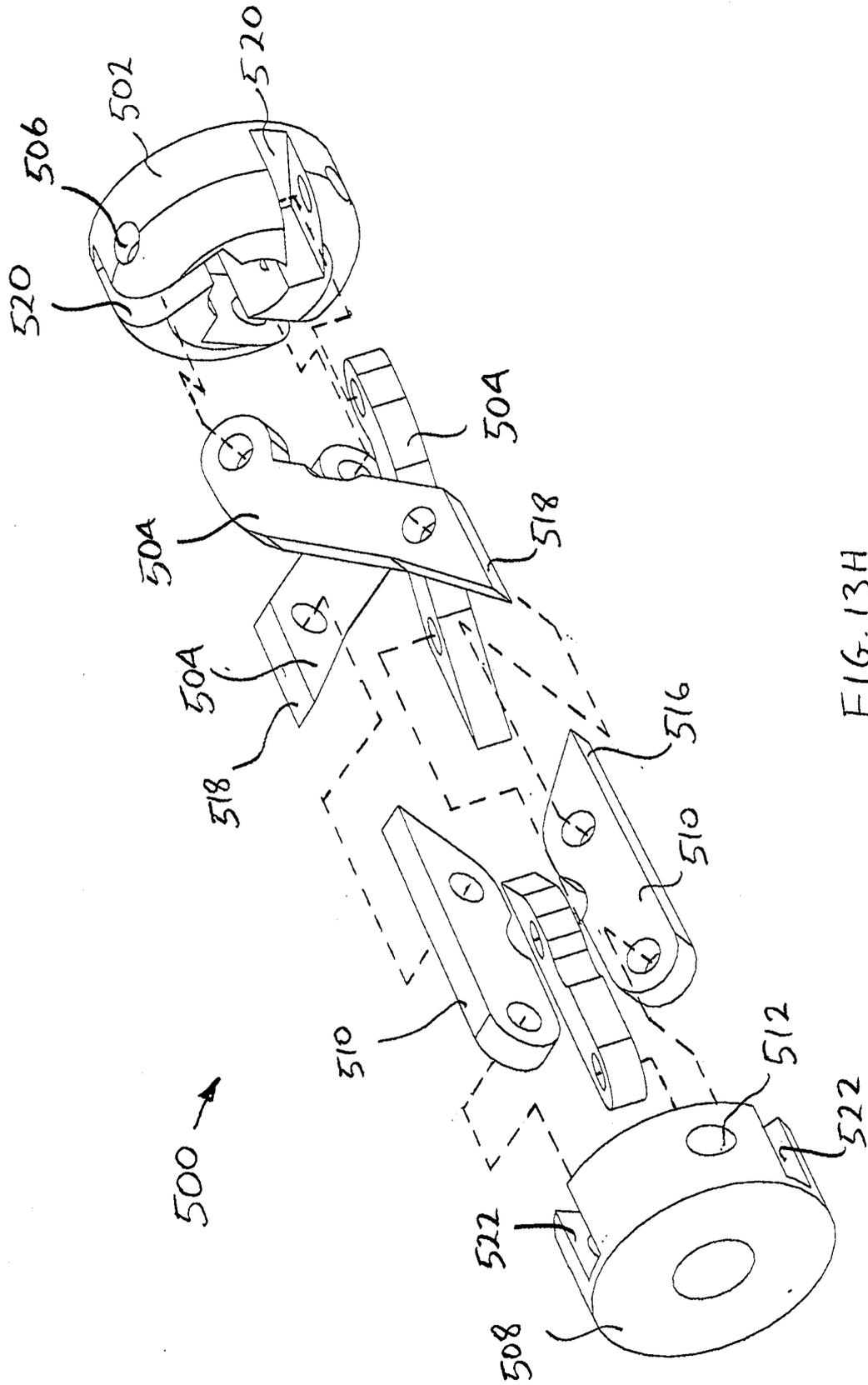

FIG. 13H

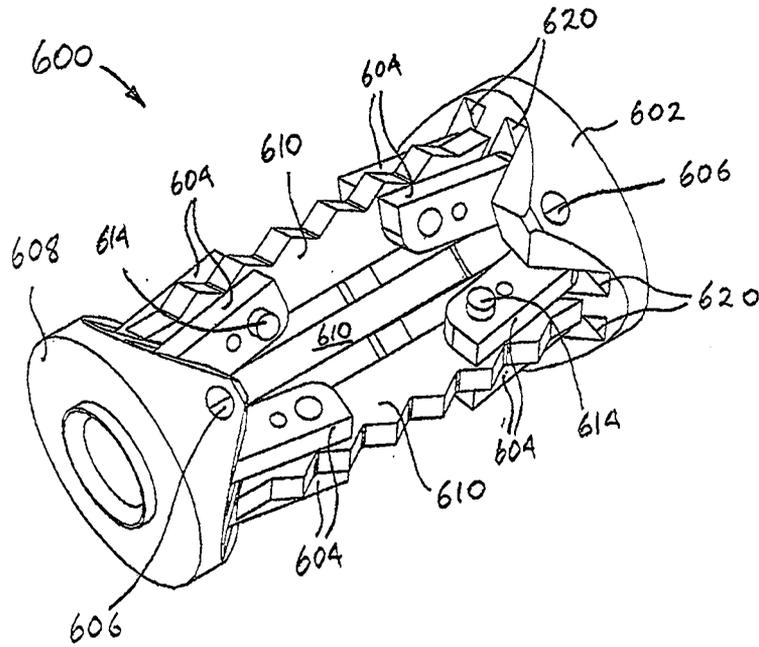

FIG. 1A A

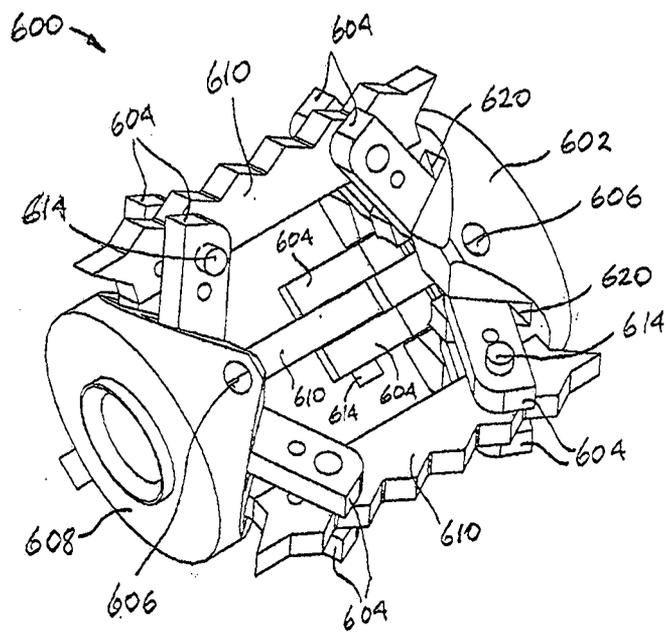
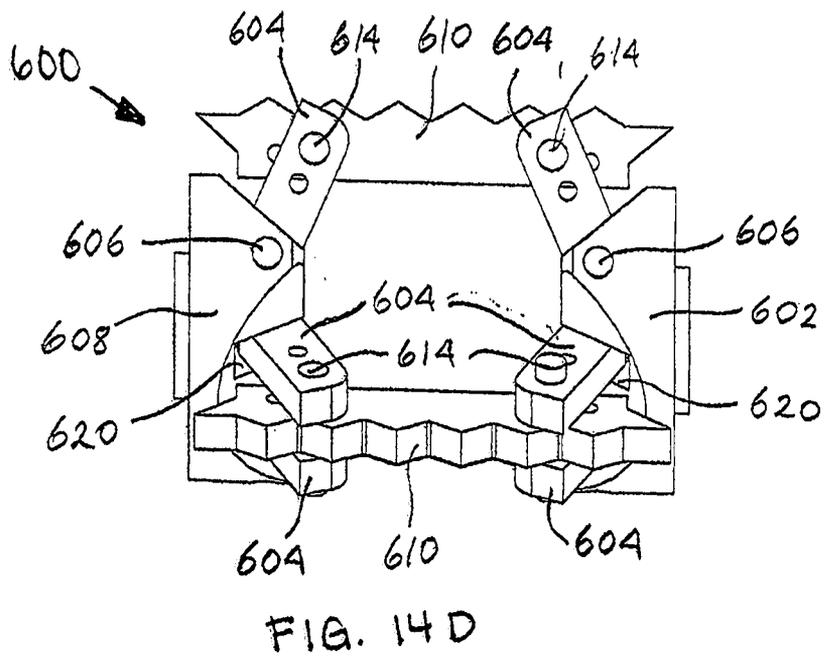
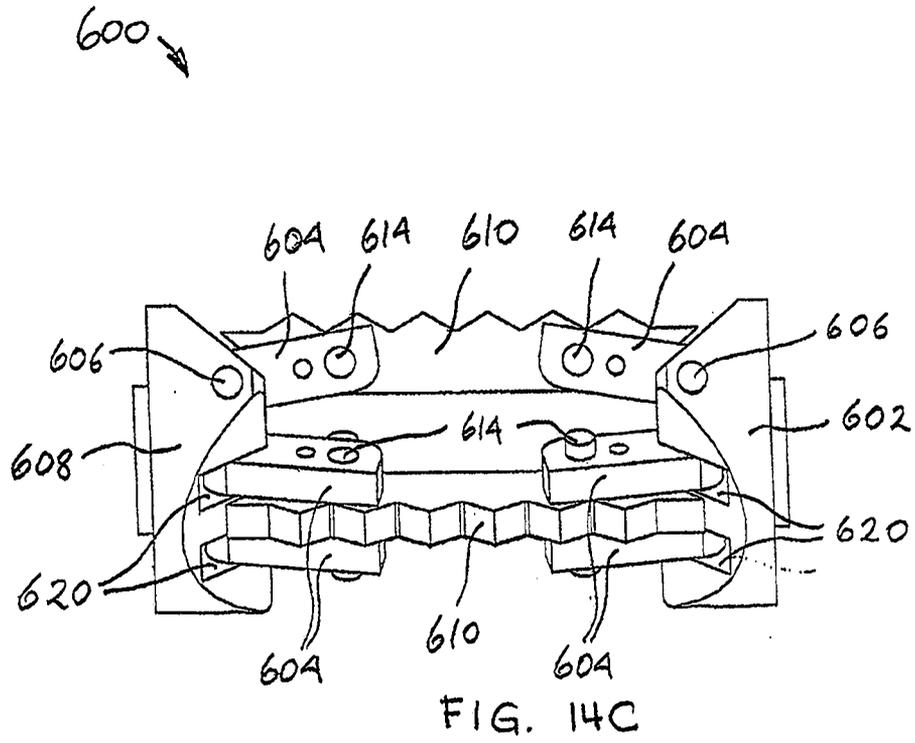

FIG. 1A B



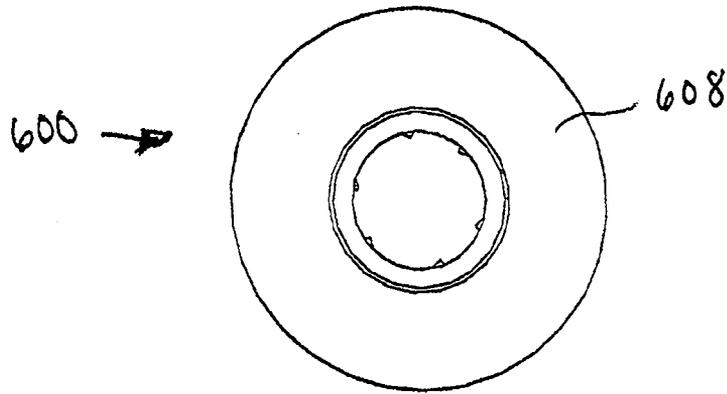

FIG. 14E

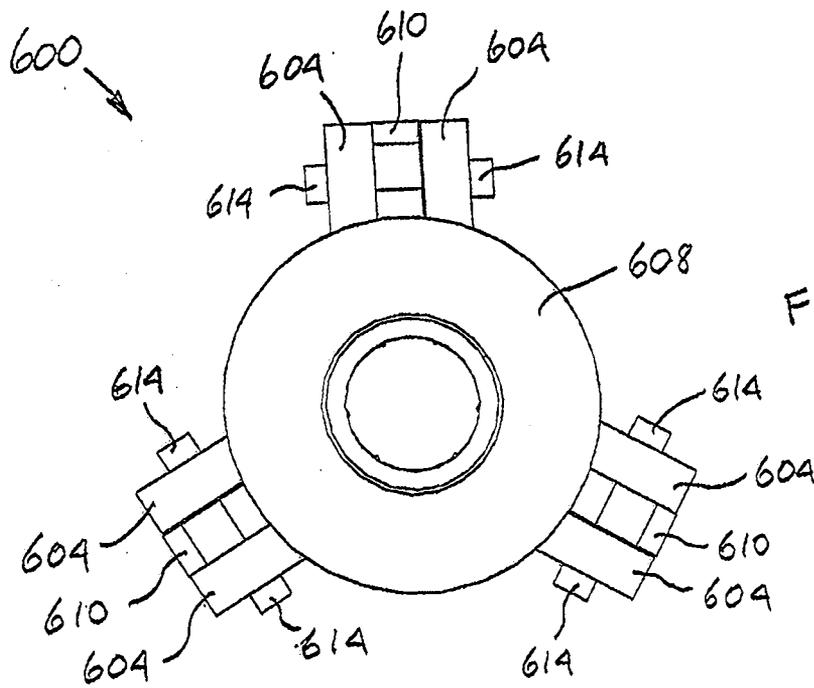

FIG. 14F

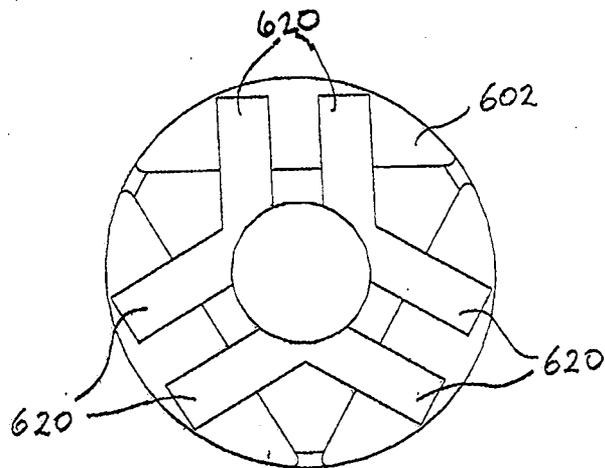

FIG. 14G

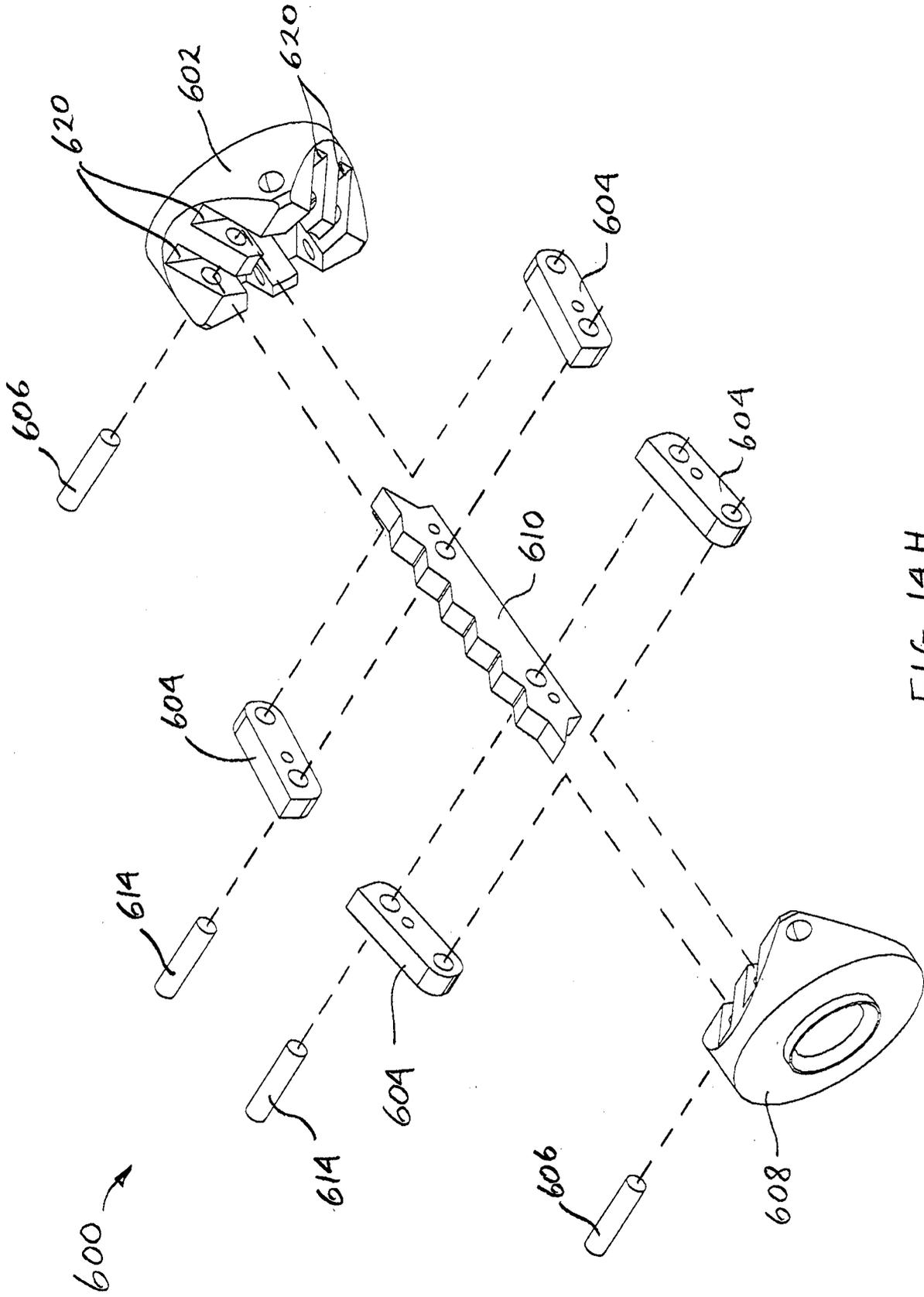
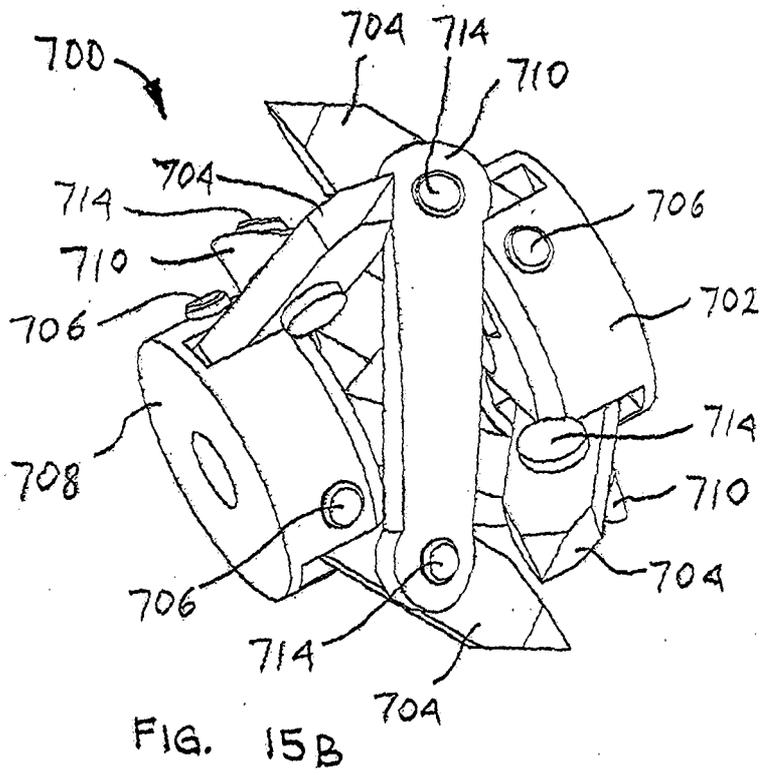
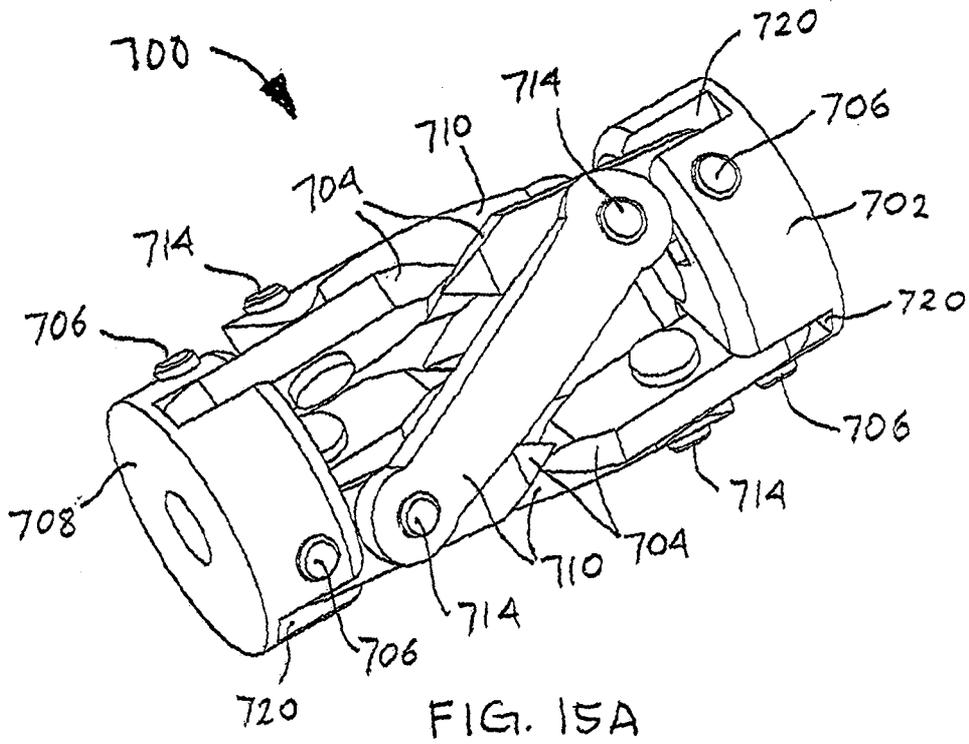
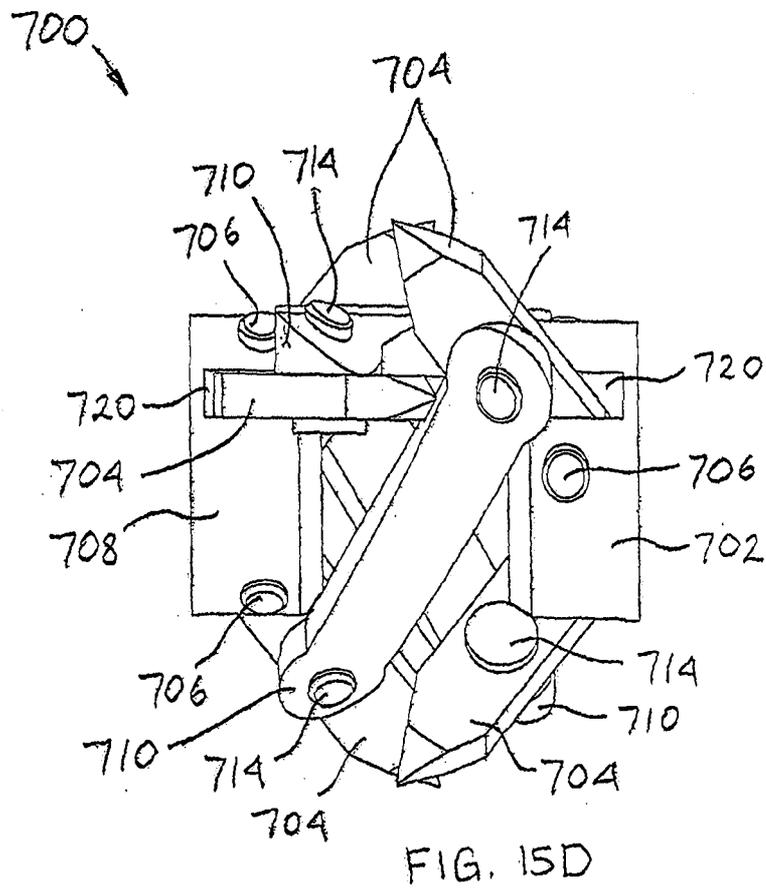
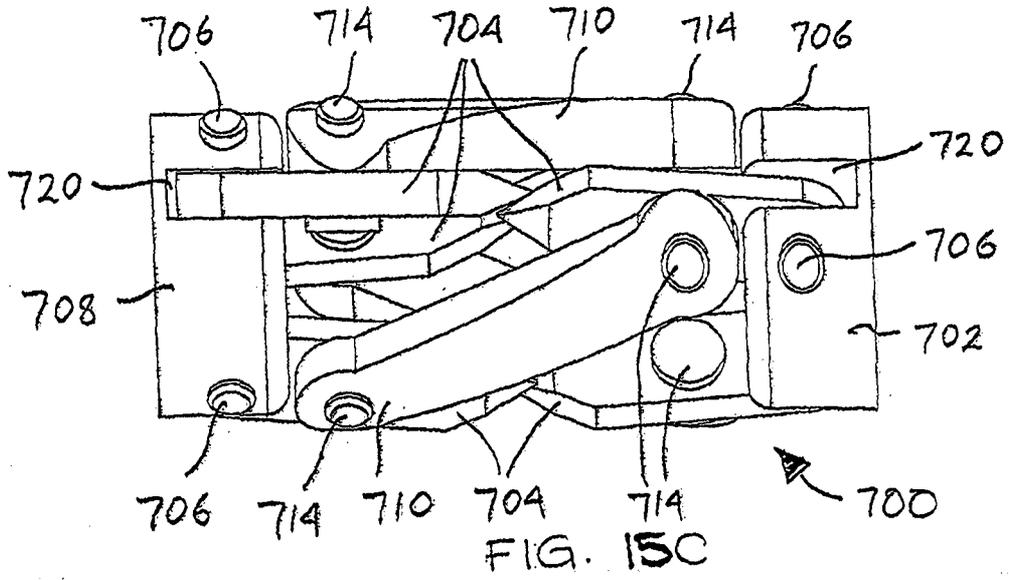

FIG. 14H





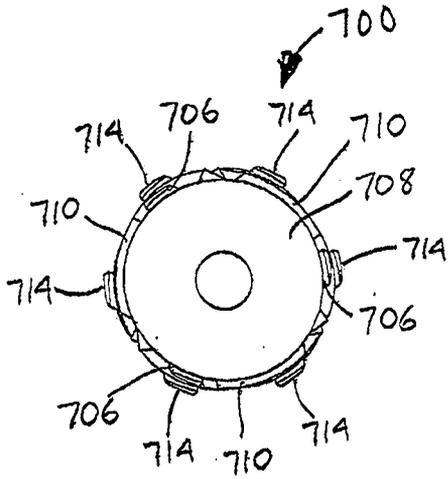

FIG. 15E

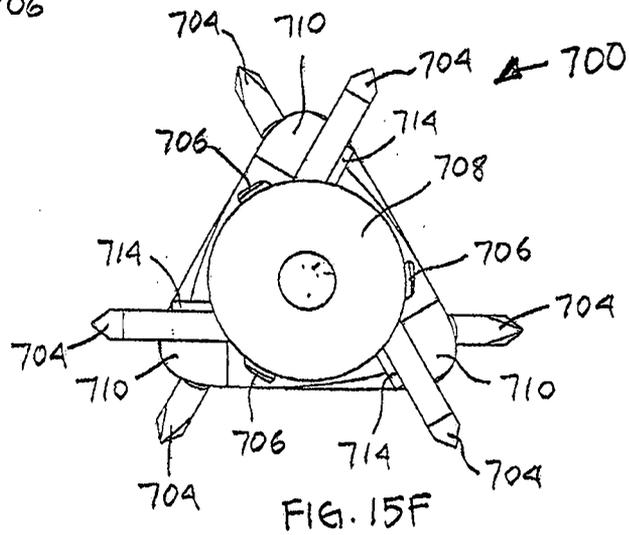

FIG. 15F

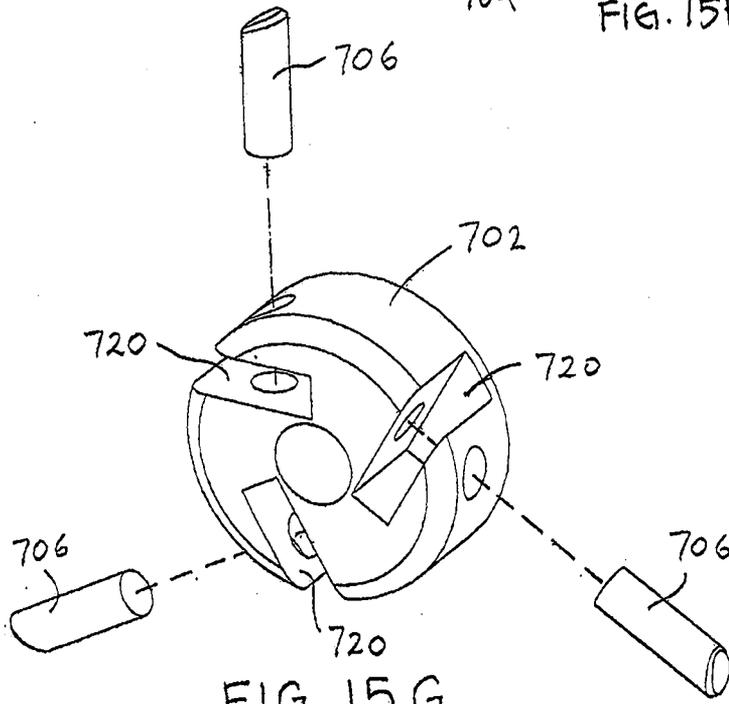

FIG. 15G

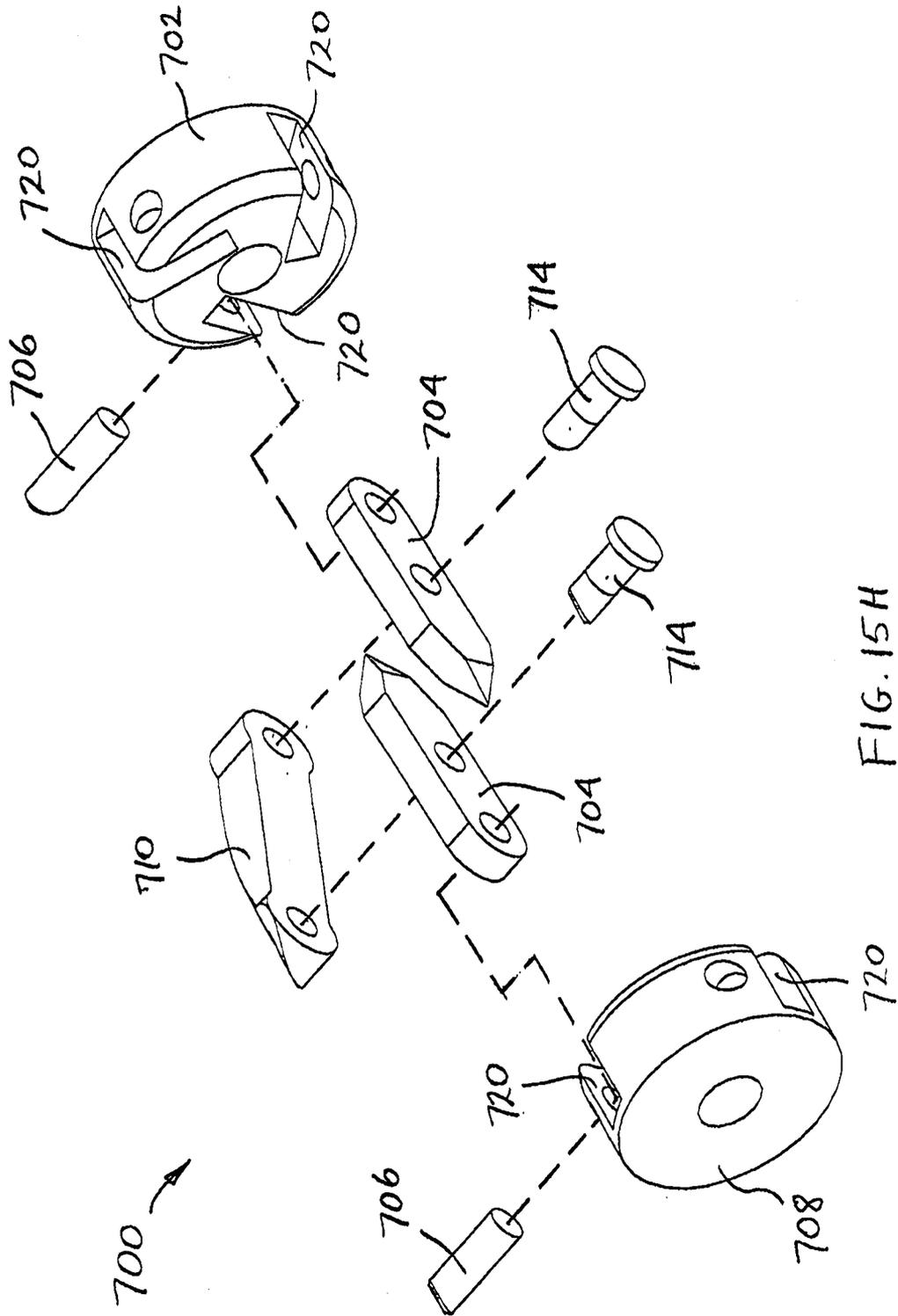

FIG. 15H

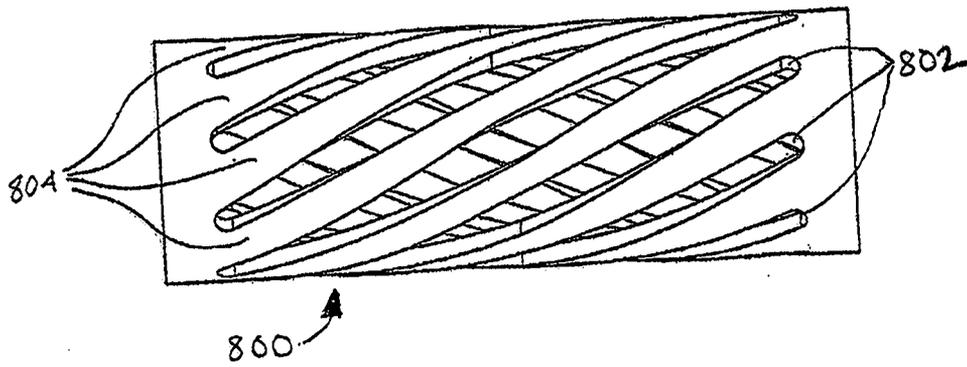
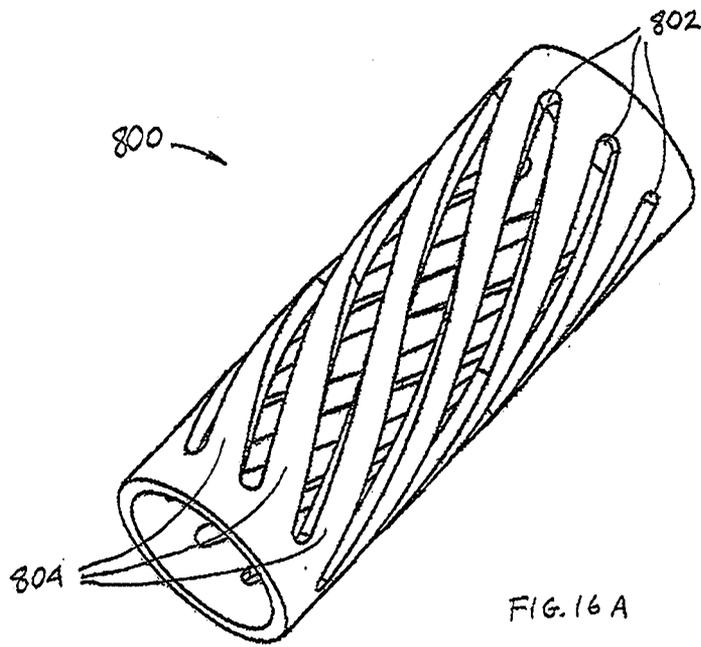
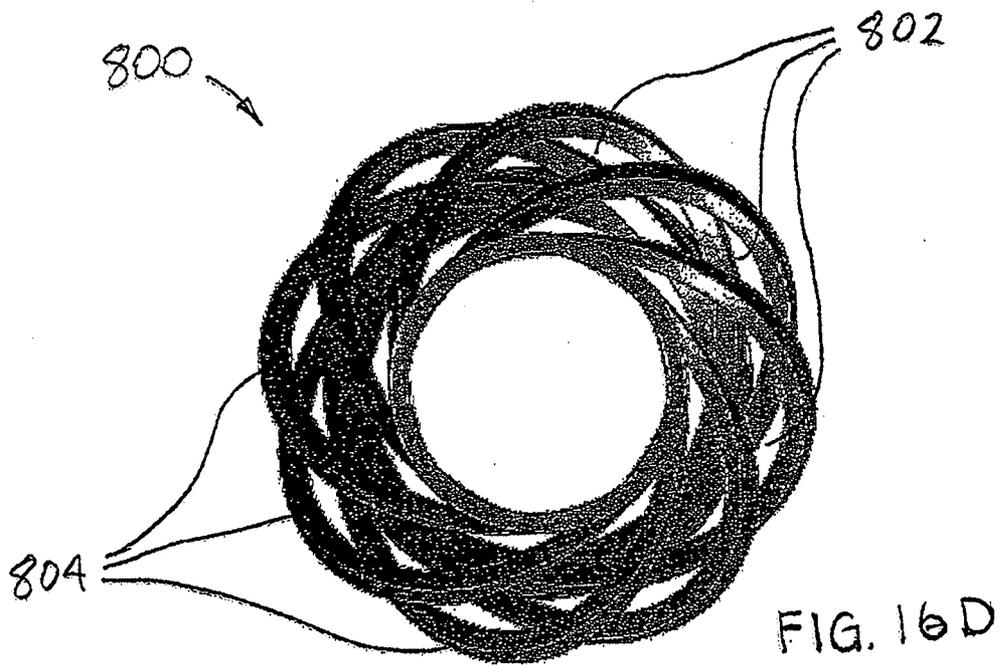
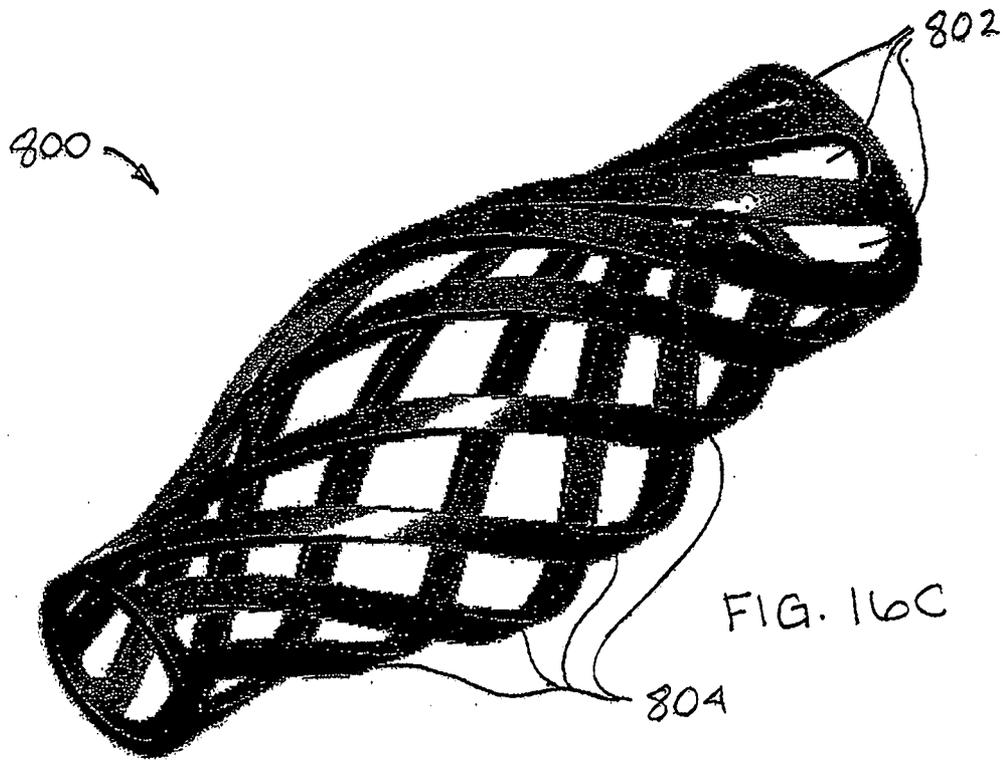

FIG. 16B



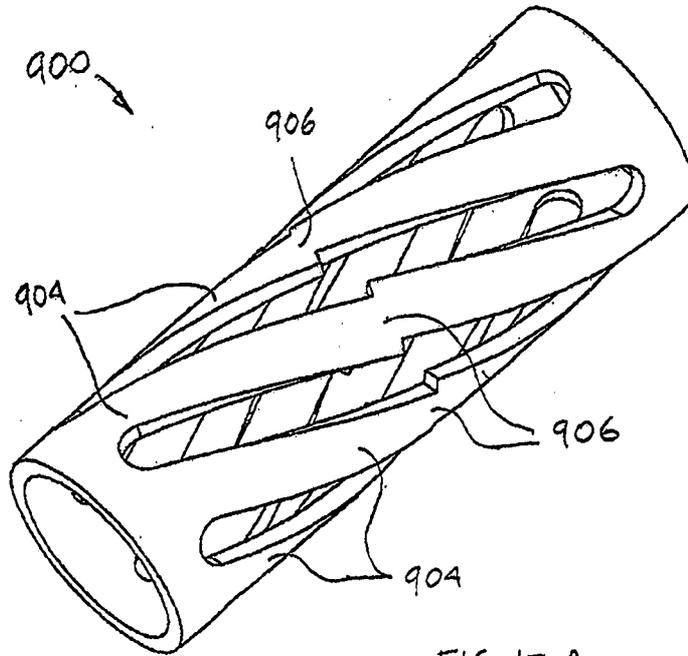

FIG. 17 A

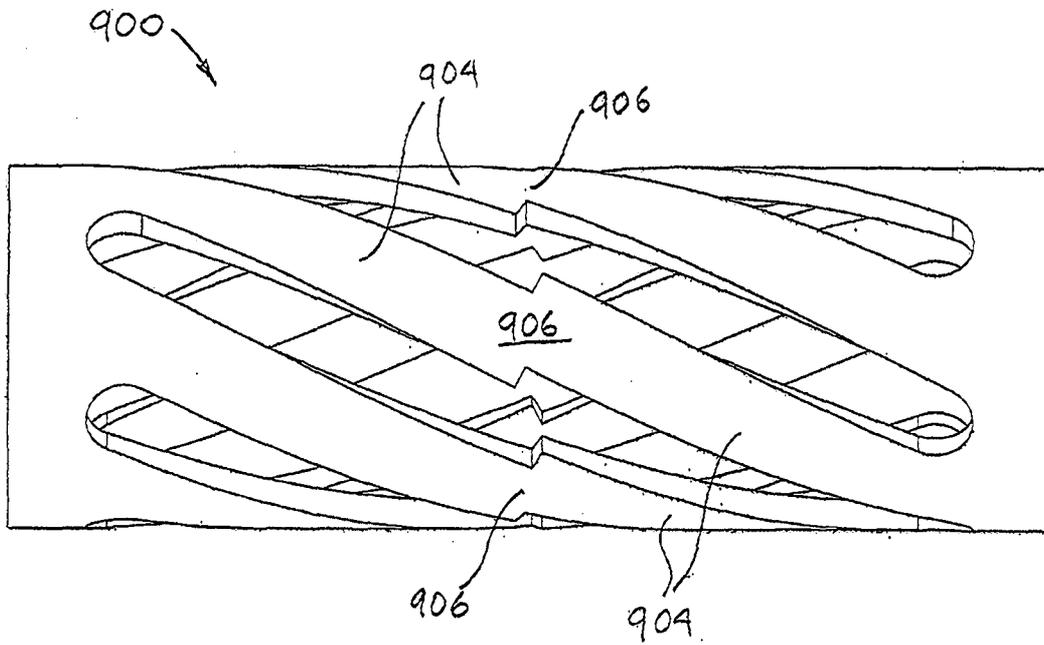

FIG. 17 B

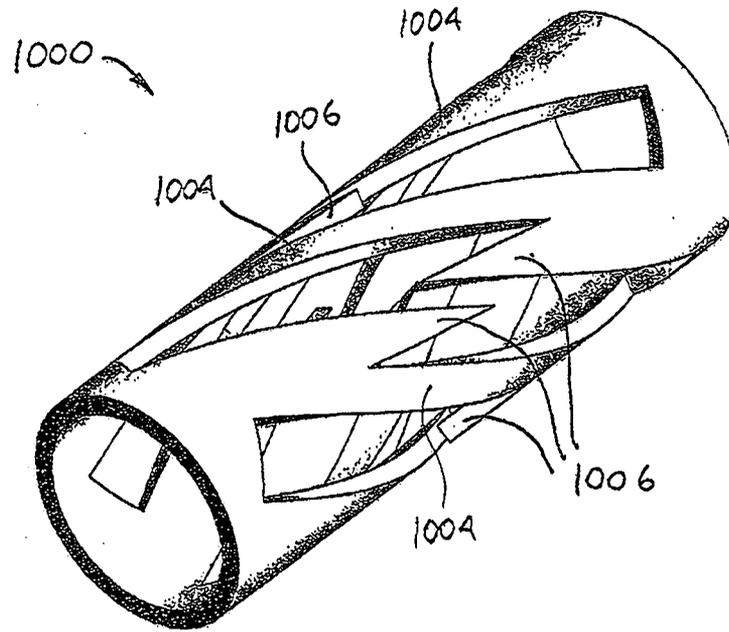

FIG. 18A

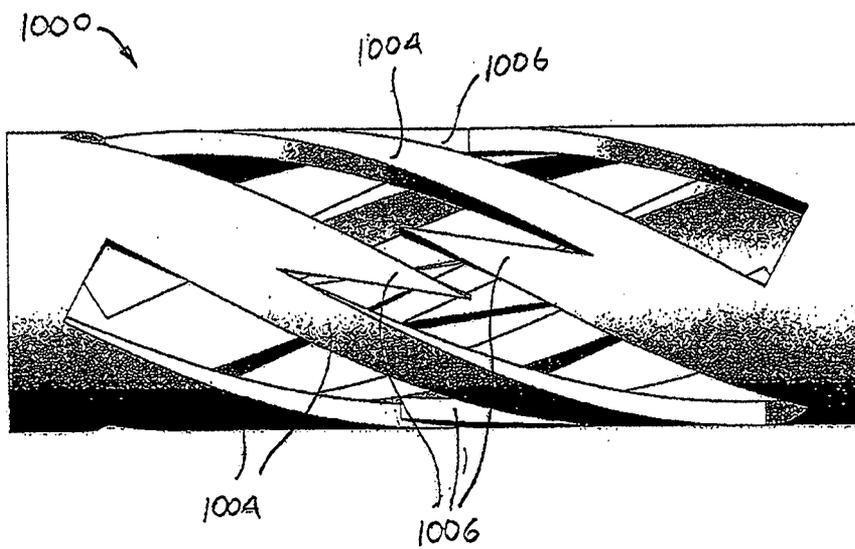

FIG. 18B

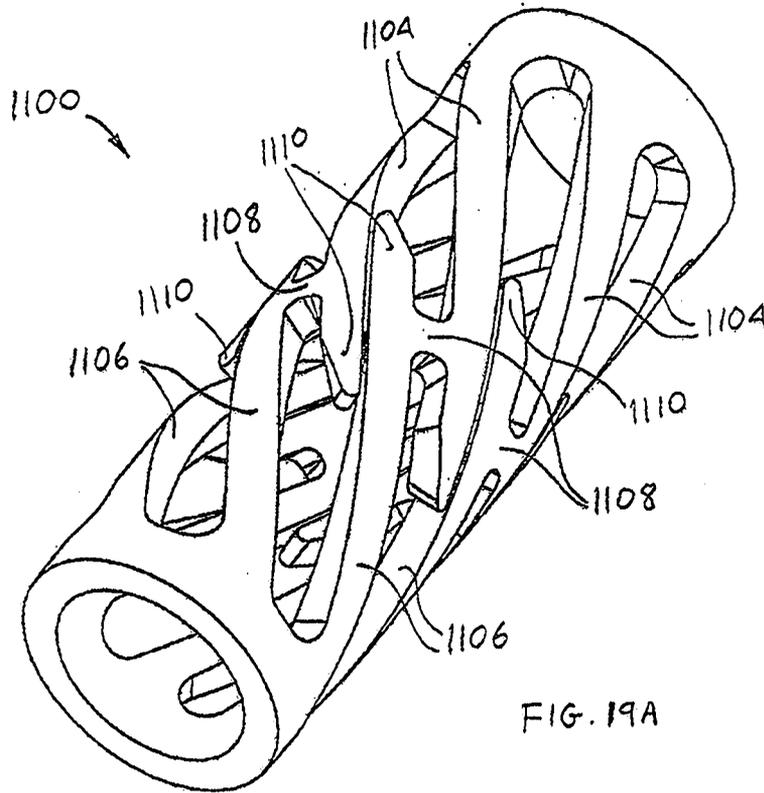

FIG. 19A

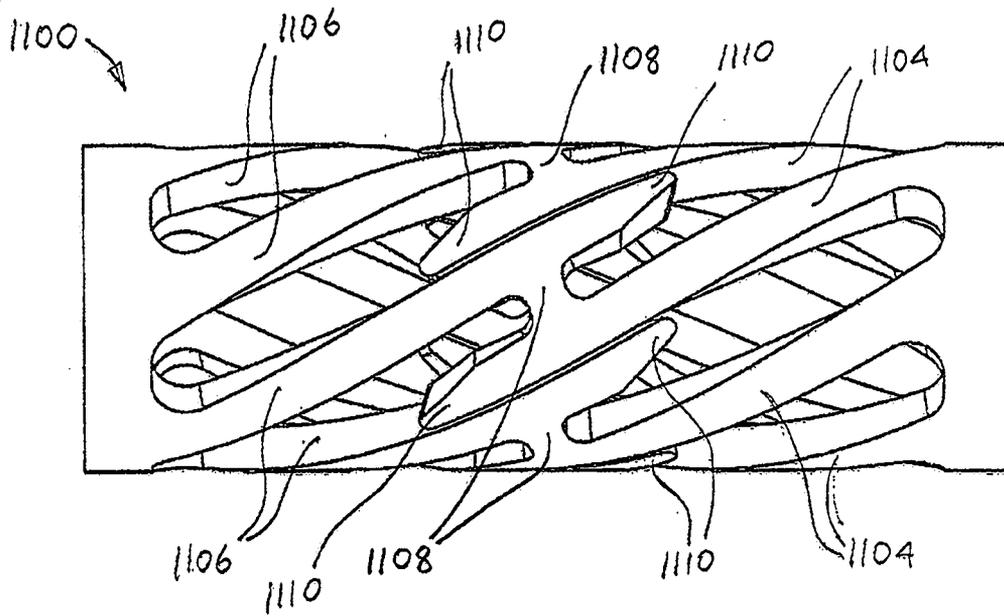
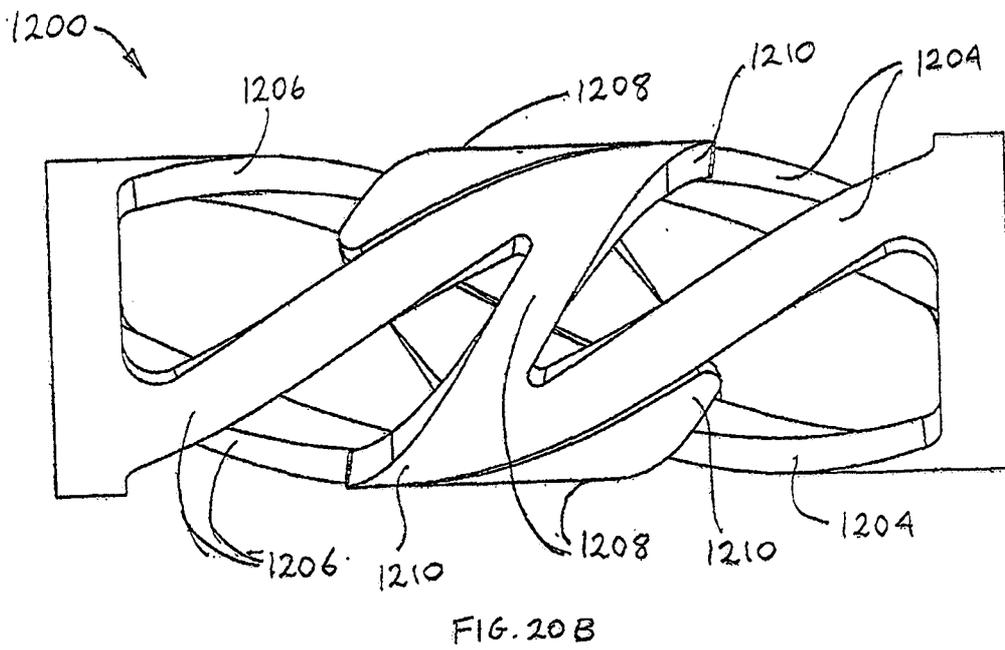
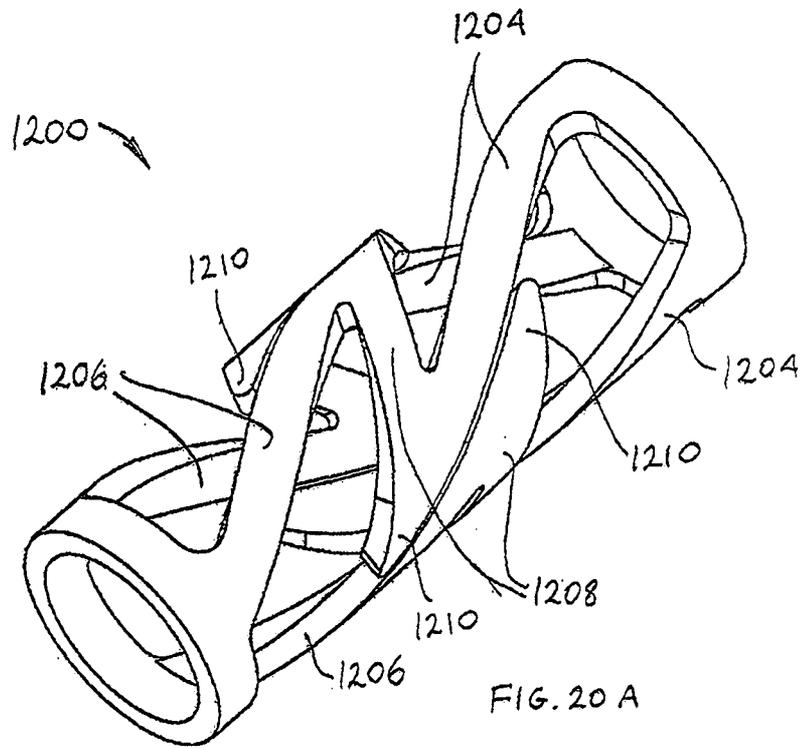

FIG. 19B



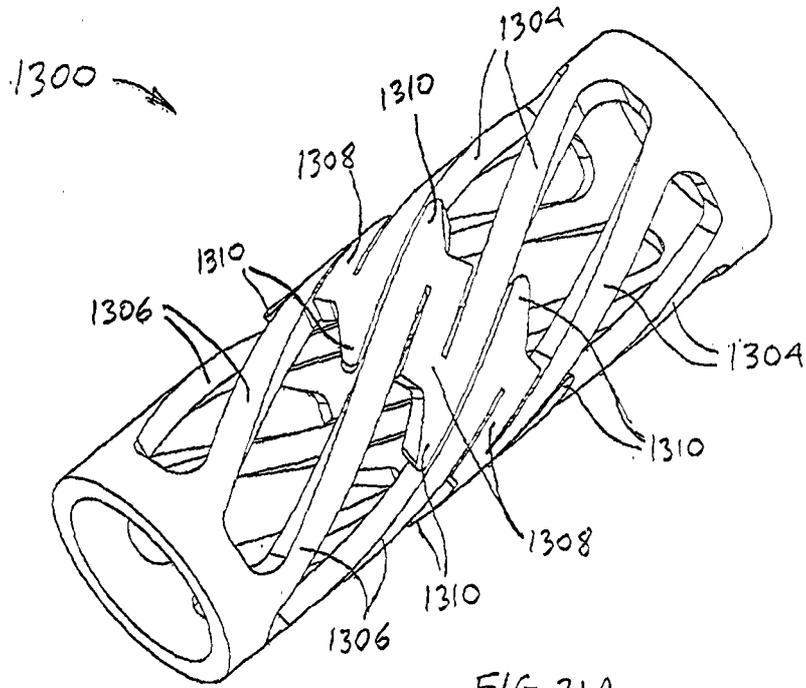

FIG. 21A

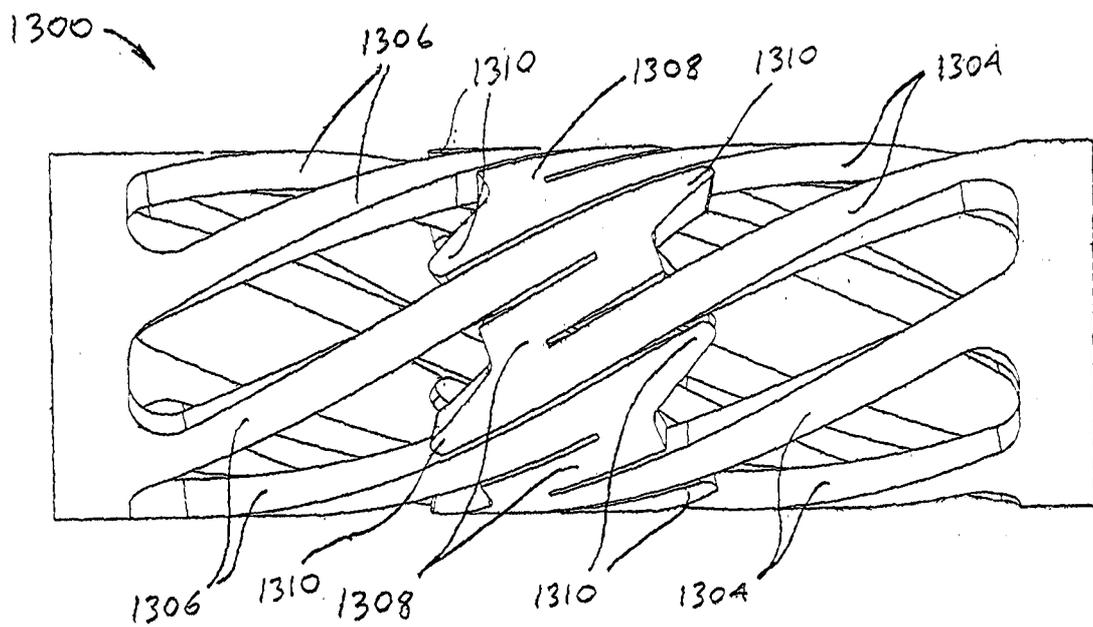

FIG. 21B

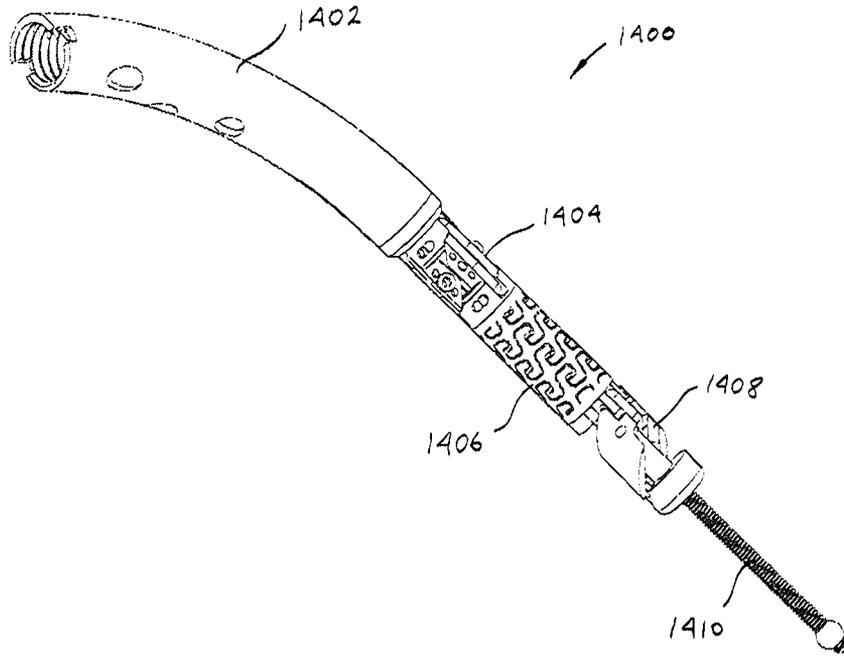

FIG. 22A

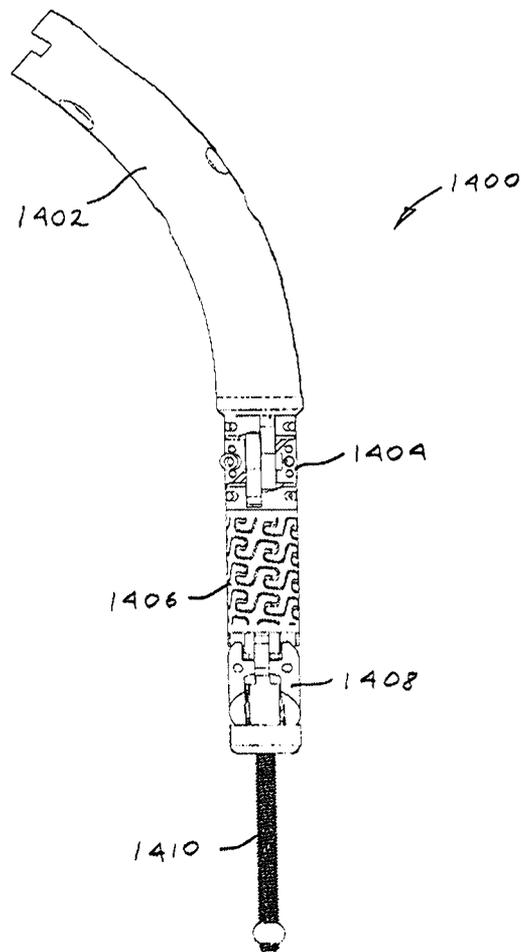

FIG. 22B

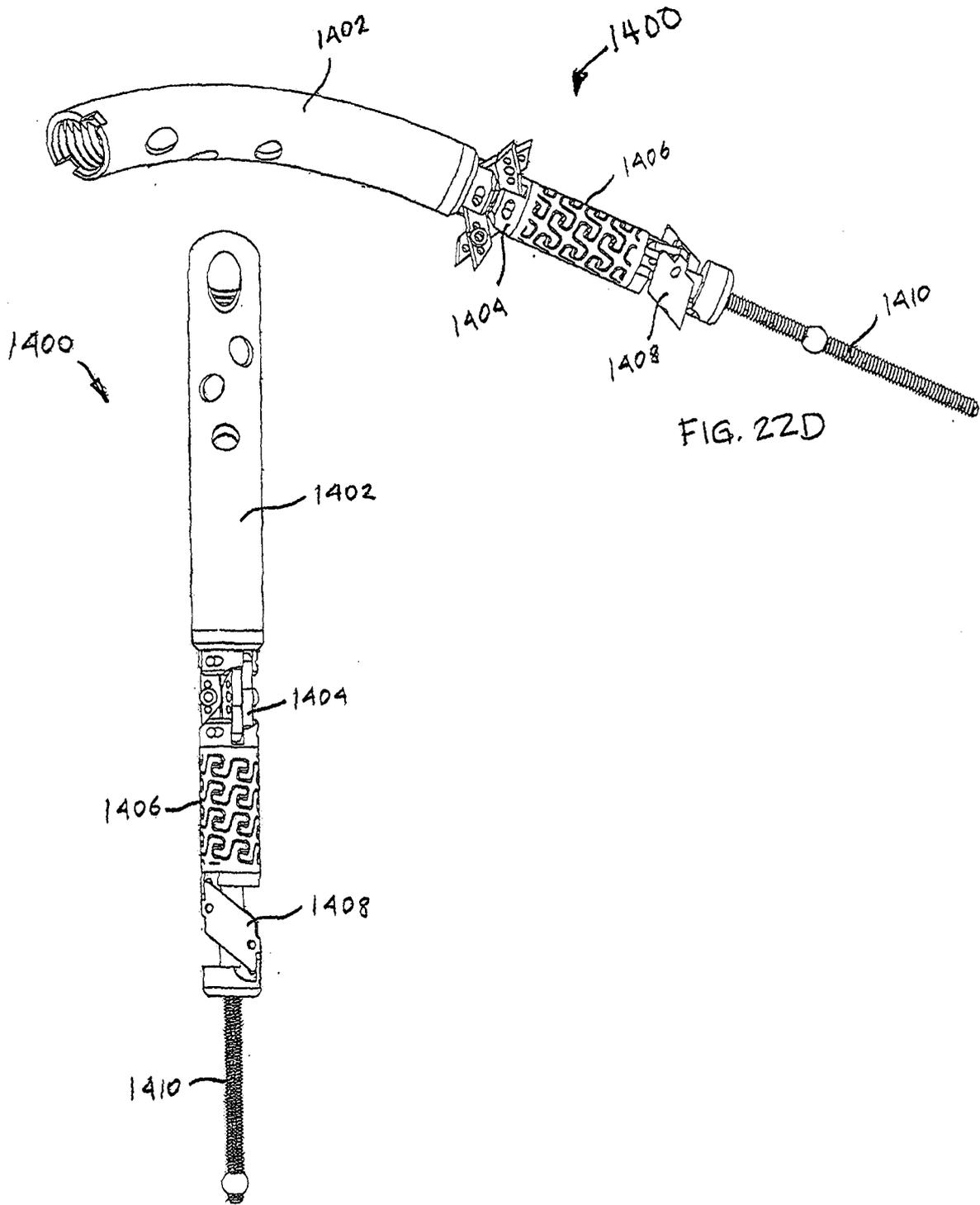

FIG. 22D

FIG. 22C

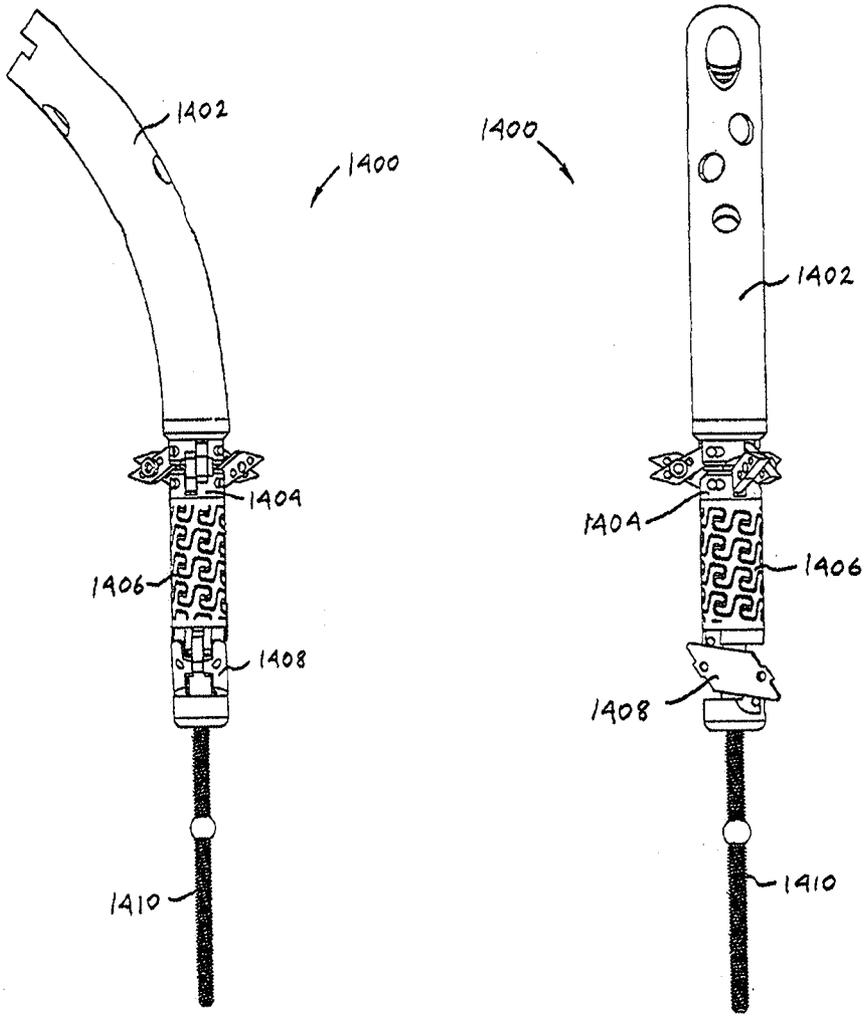
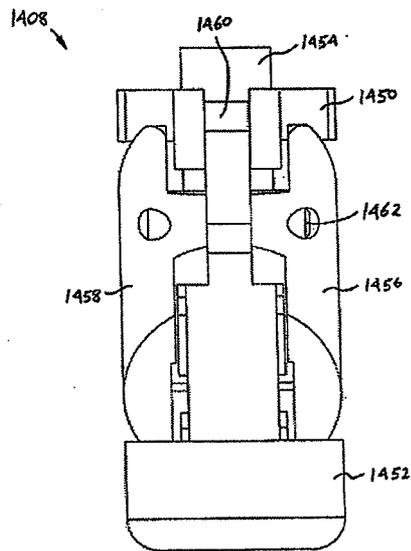
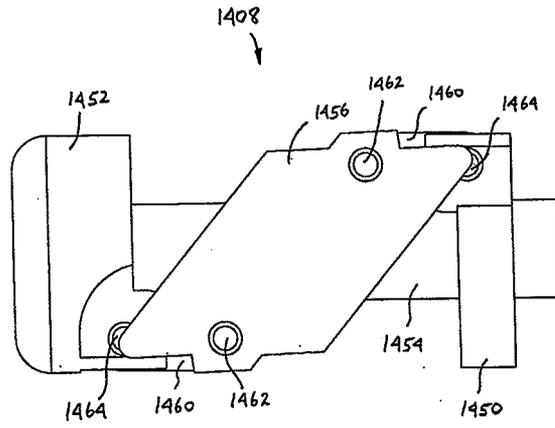
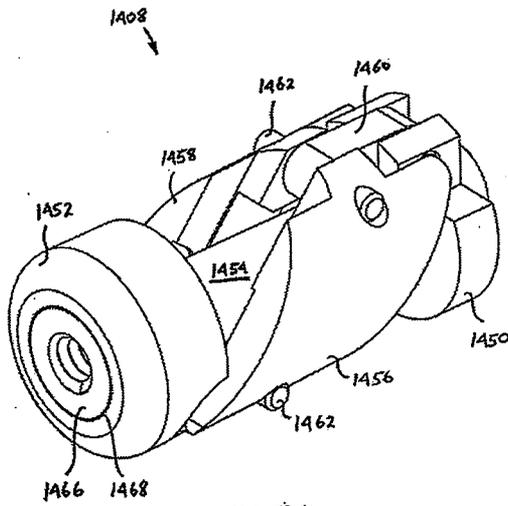

FIG. 22 E

FIG. 22 F



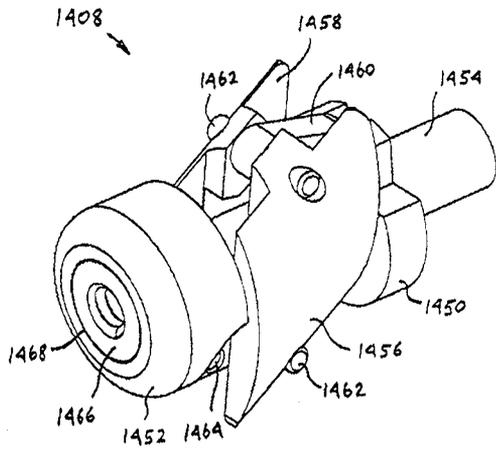

FIG. 23D

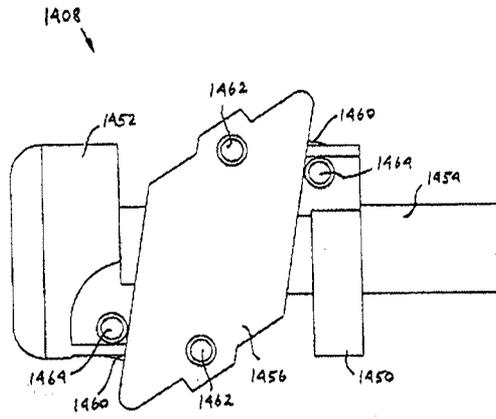

FIG. 23E

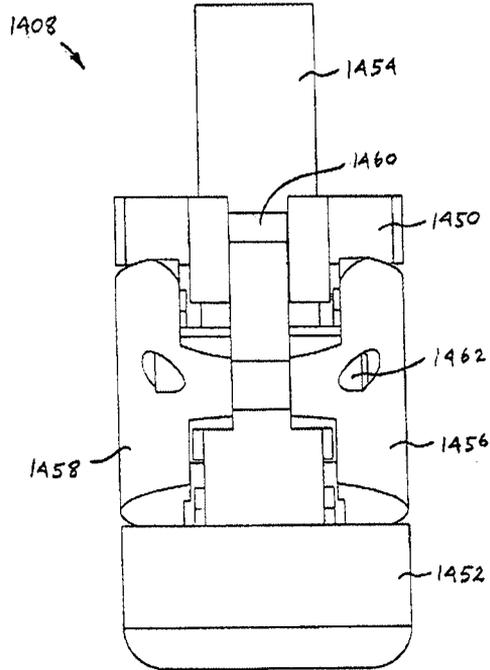

FIG. 23F

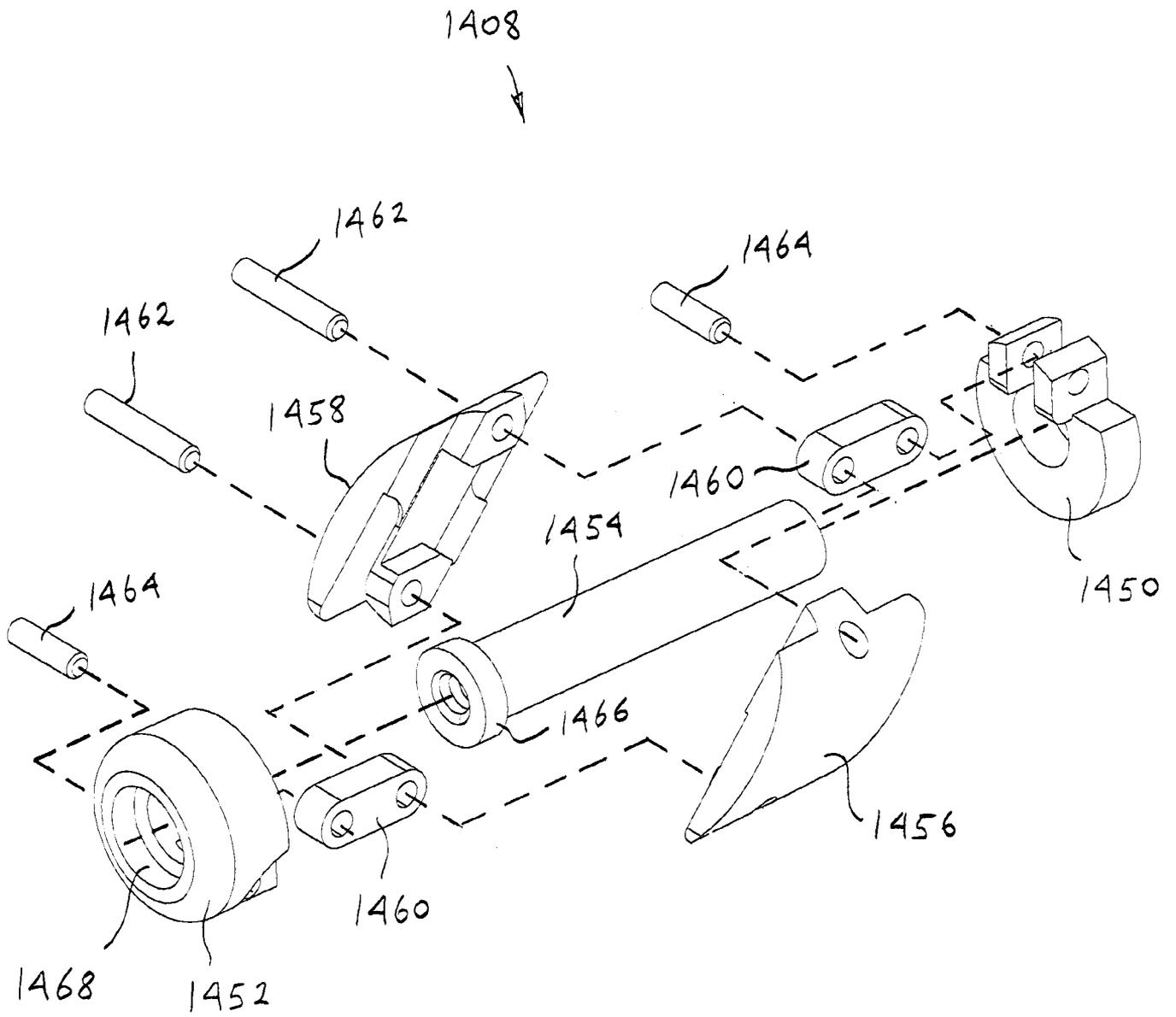

FIG. 23G

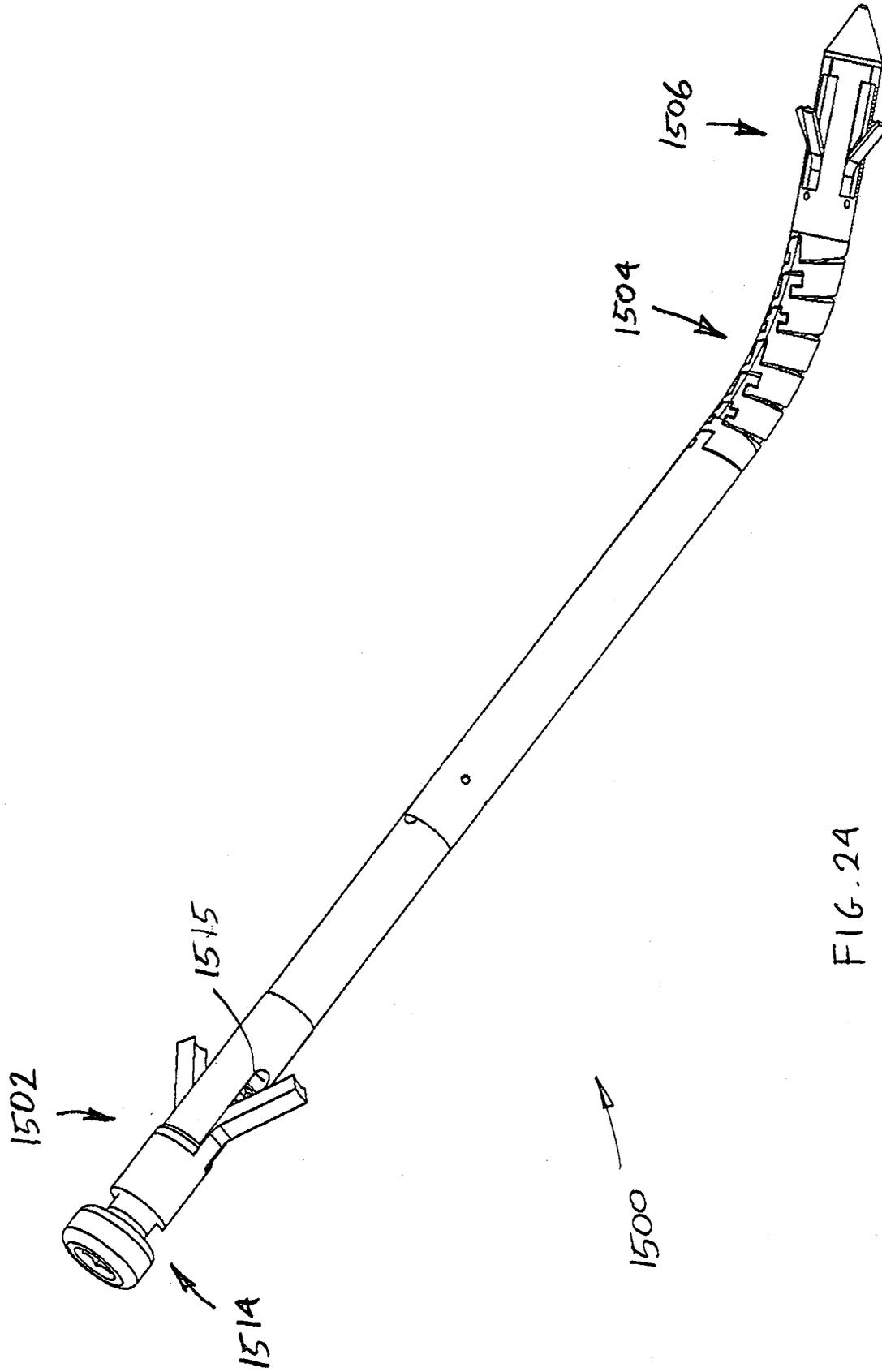

FIG. 2A

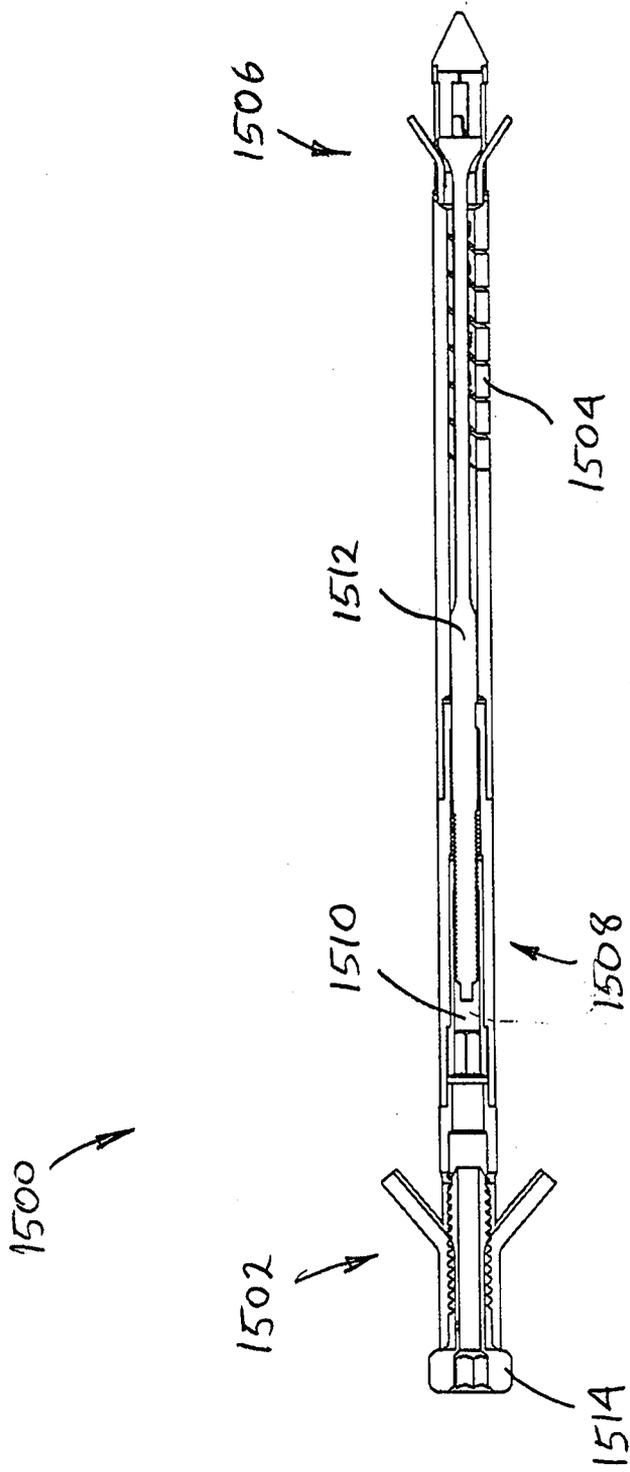

FIG. 25

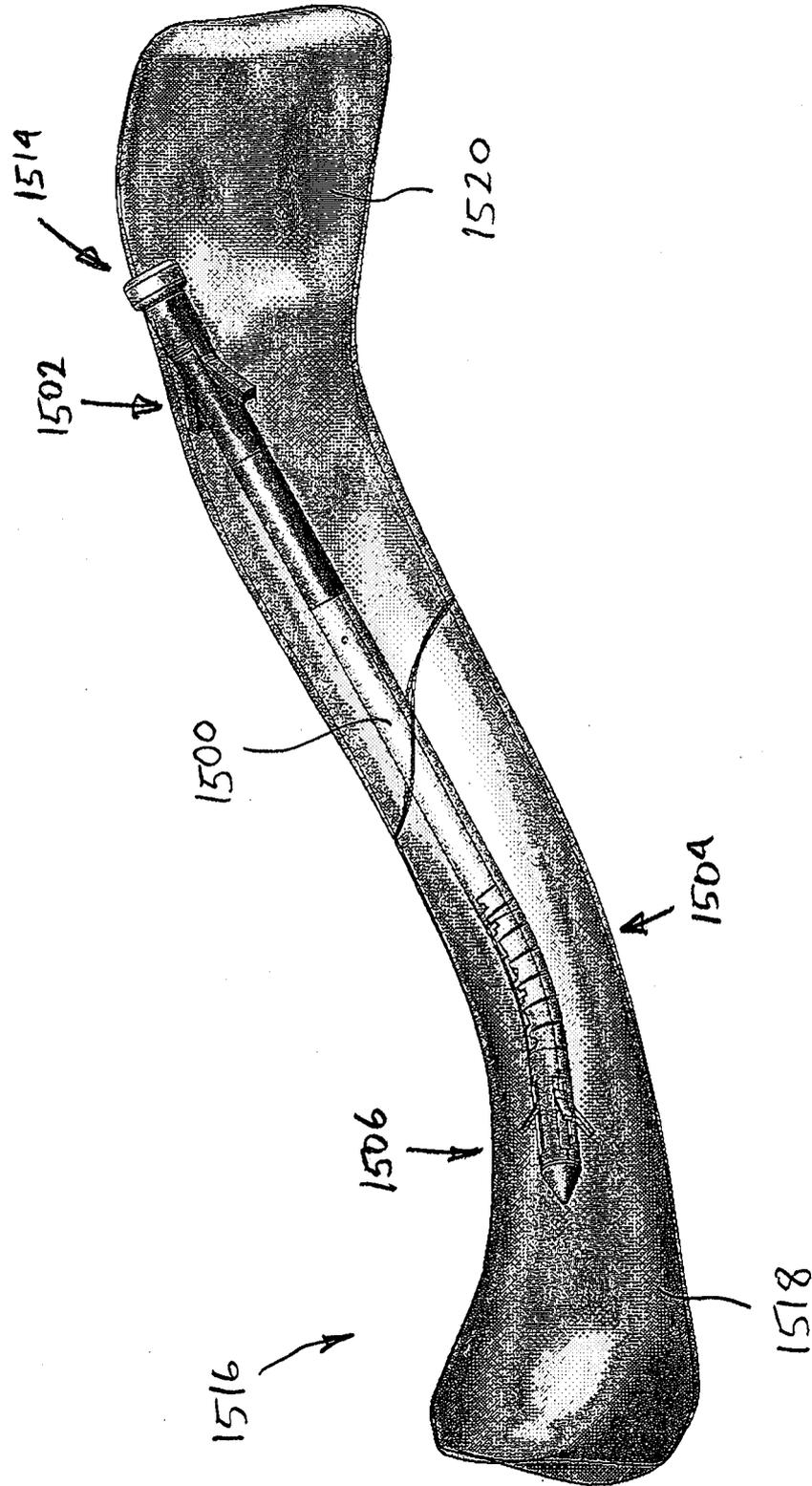

FIG. 26

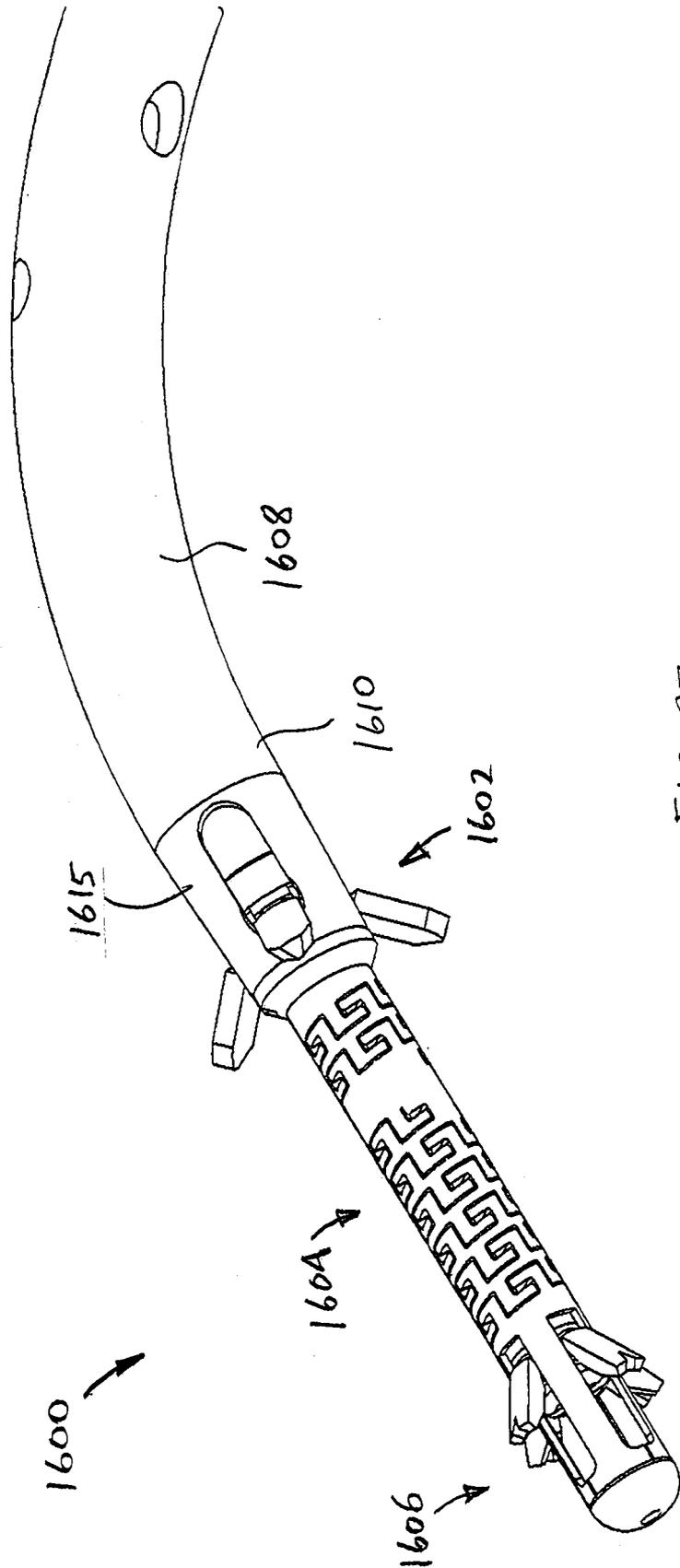

FIG. 27

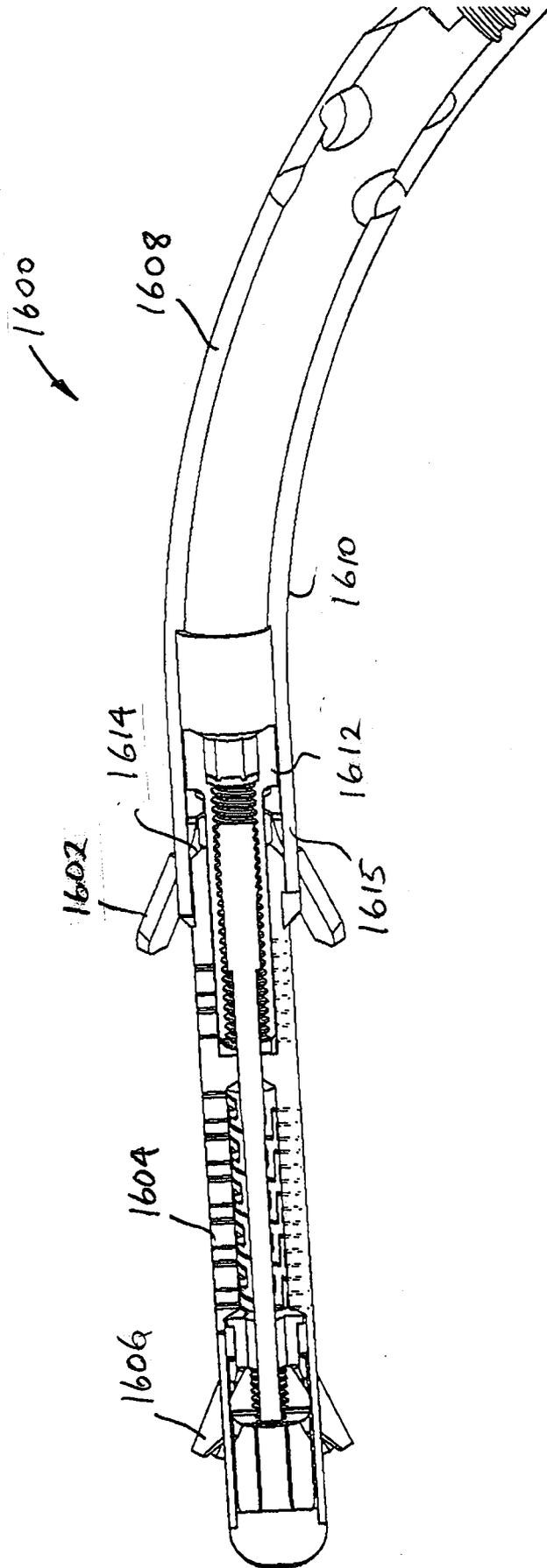

FIG. 28

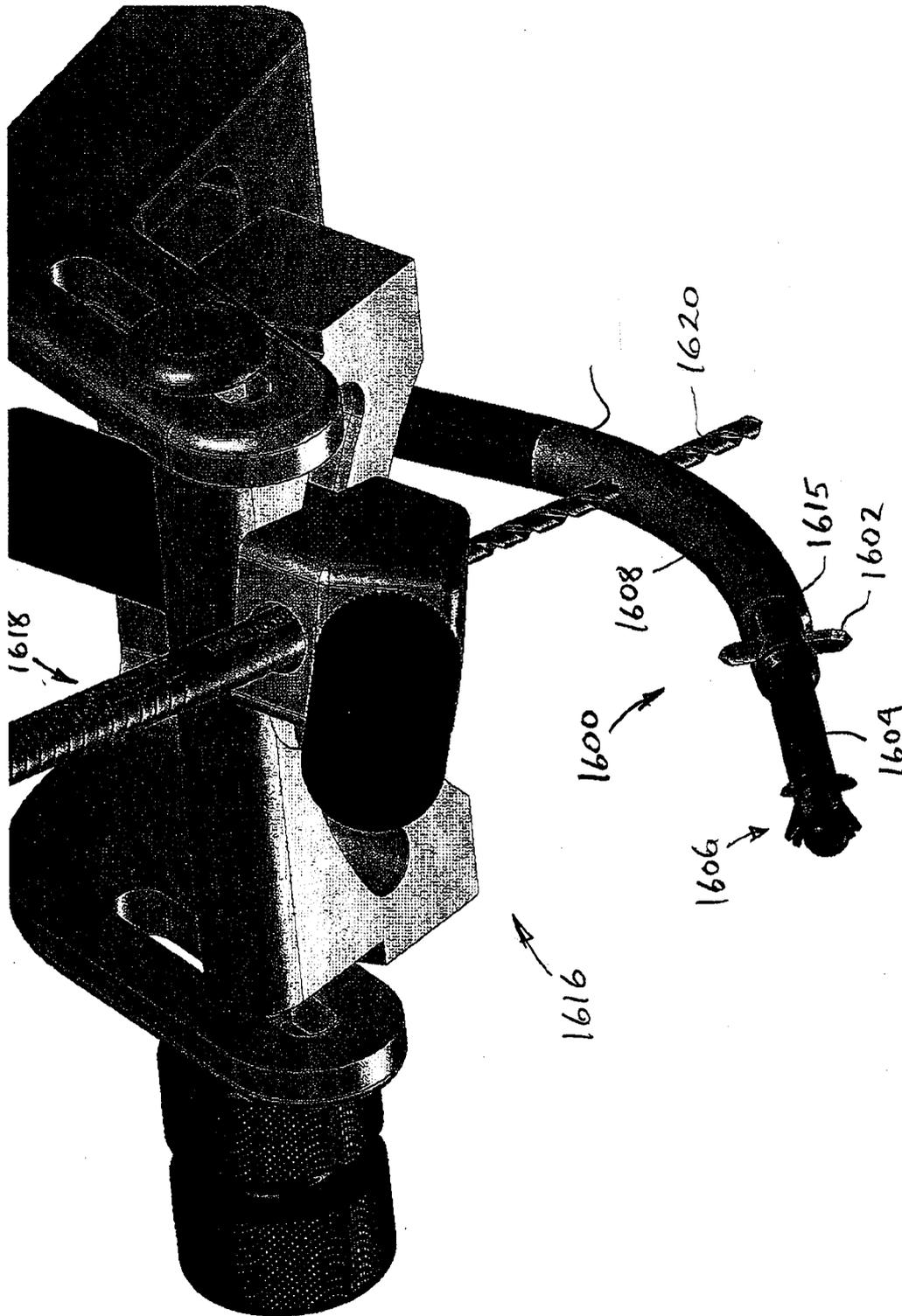

FIG. 29

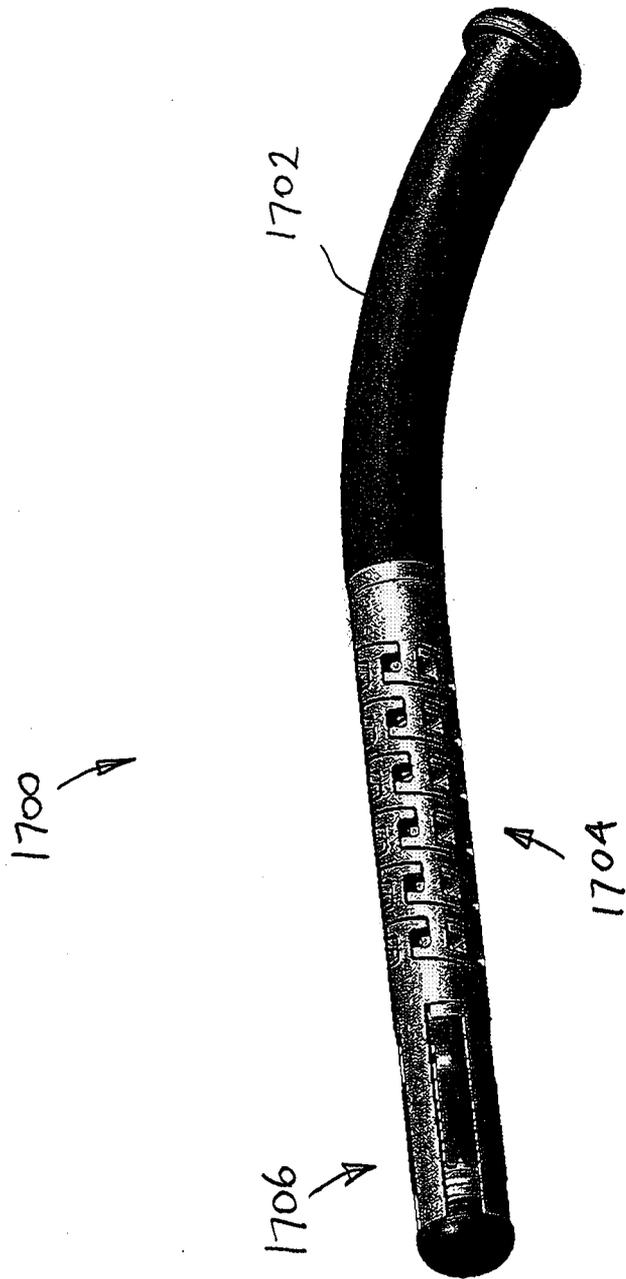

FIG. 30

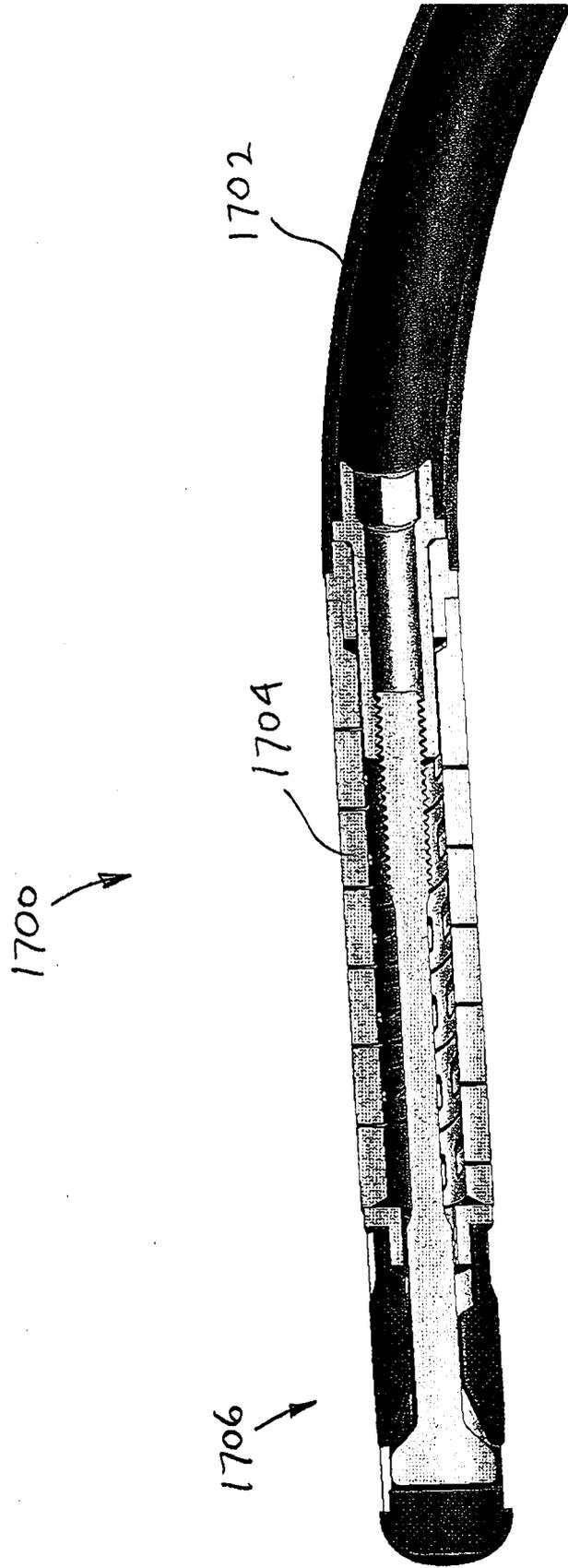

FIG. 31

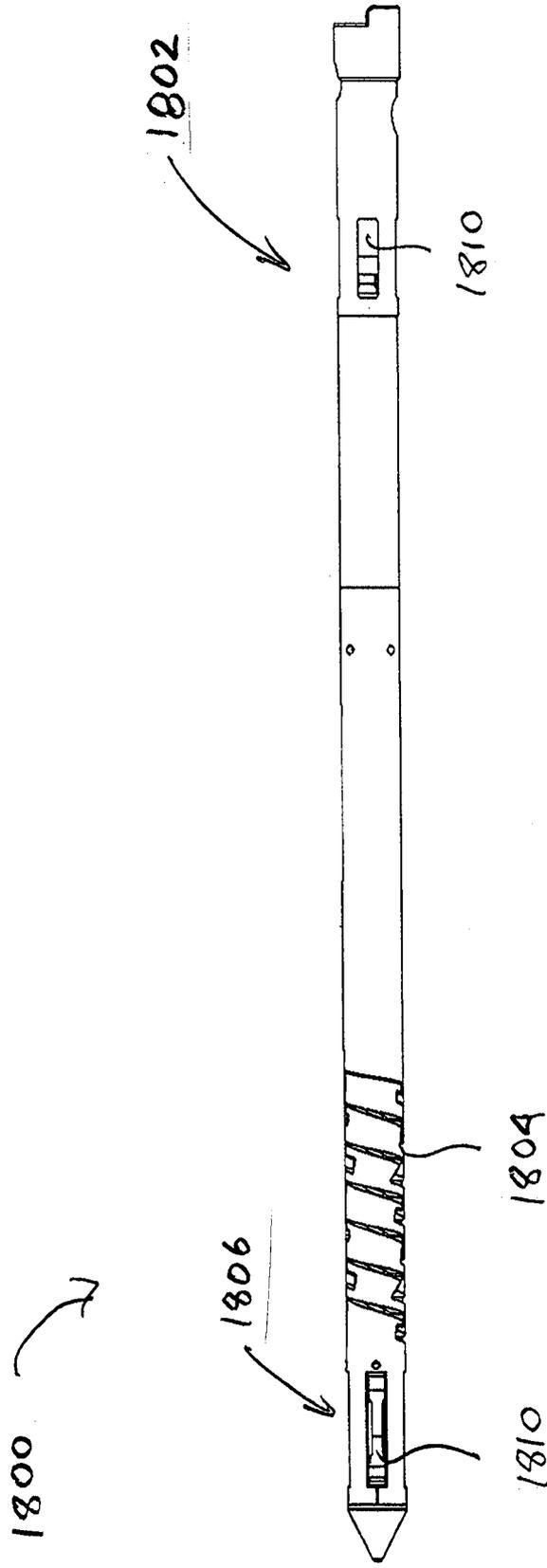

FIG. 32

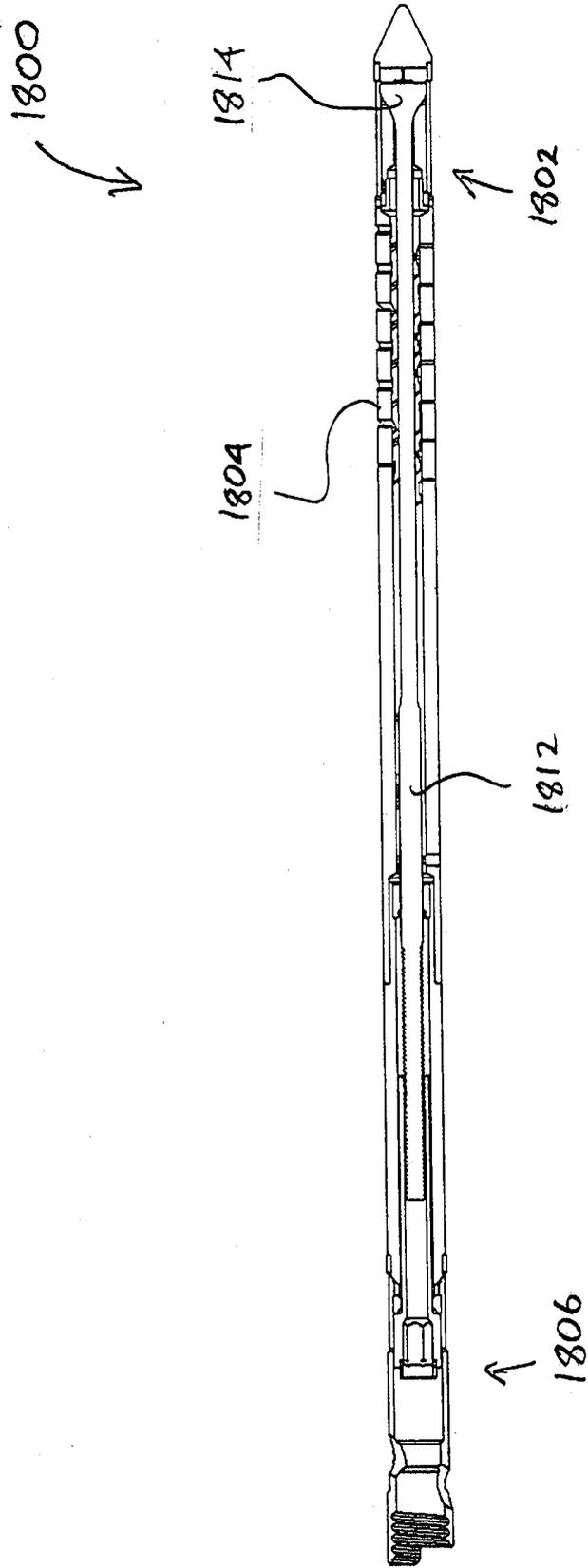

FIG. 33

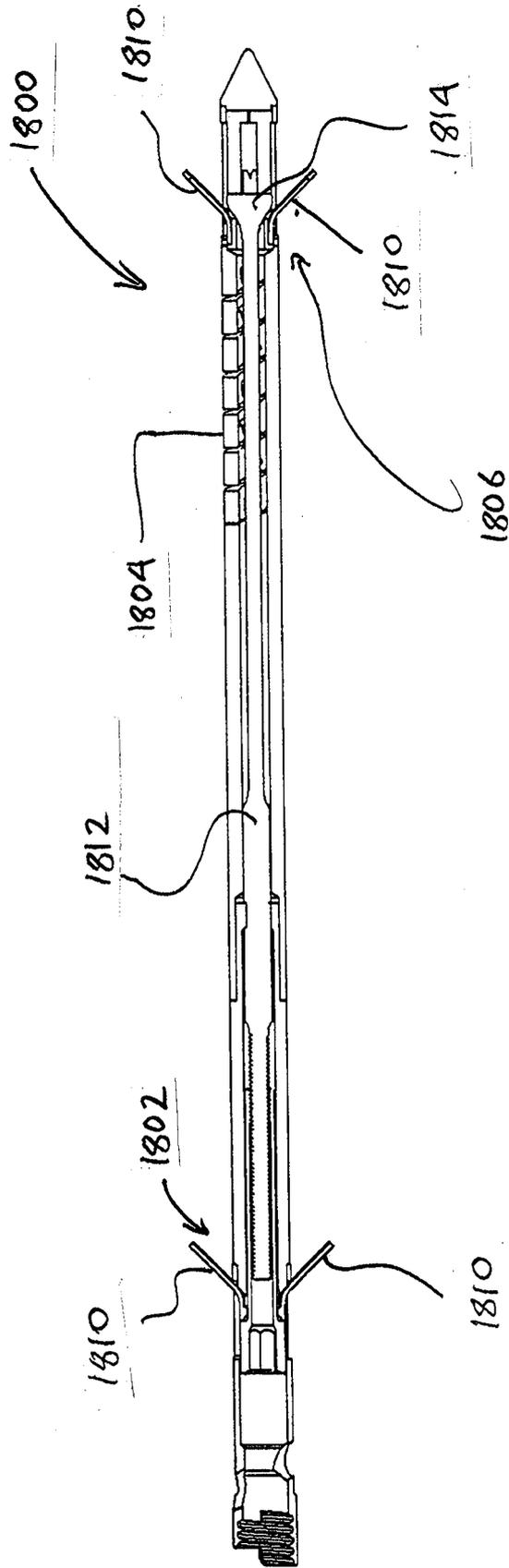

FIG. 3A

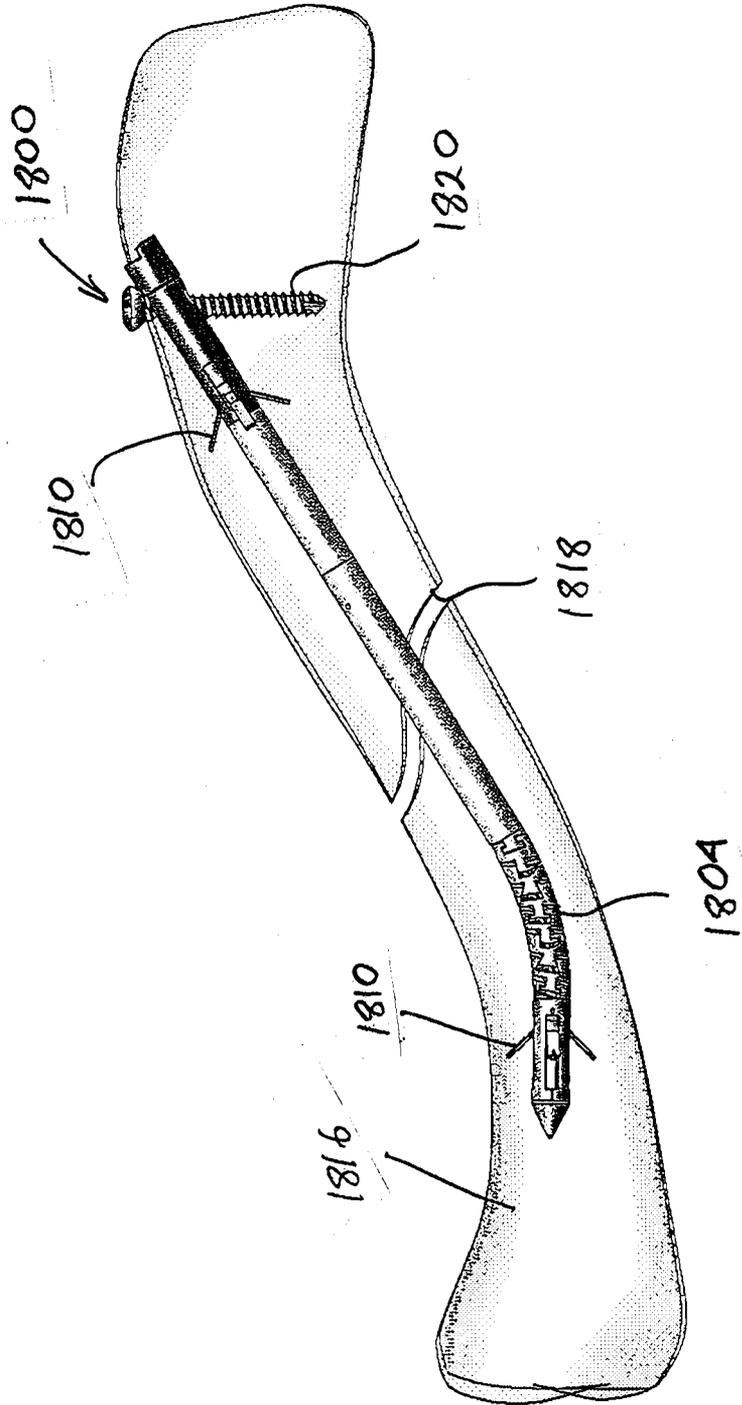

FIG. 35

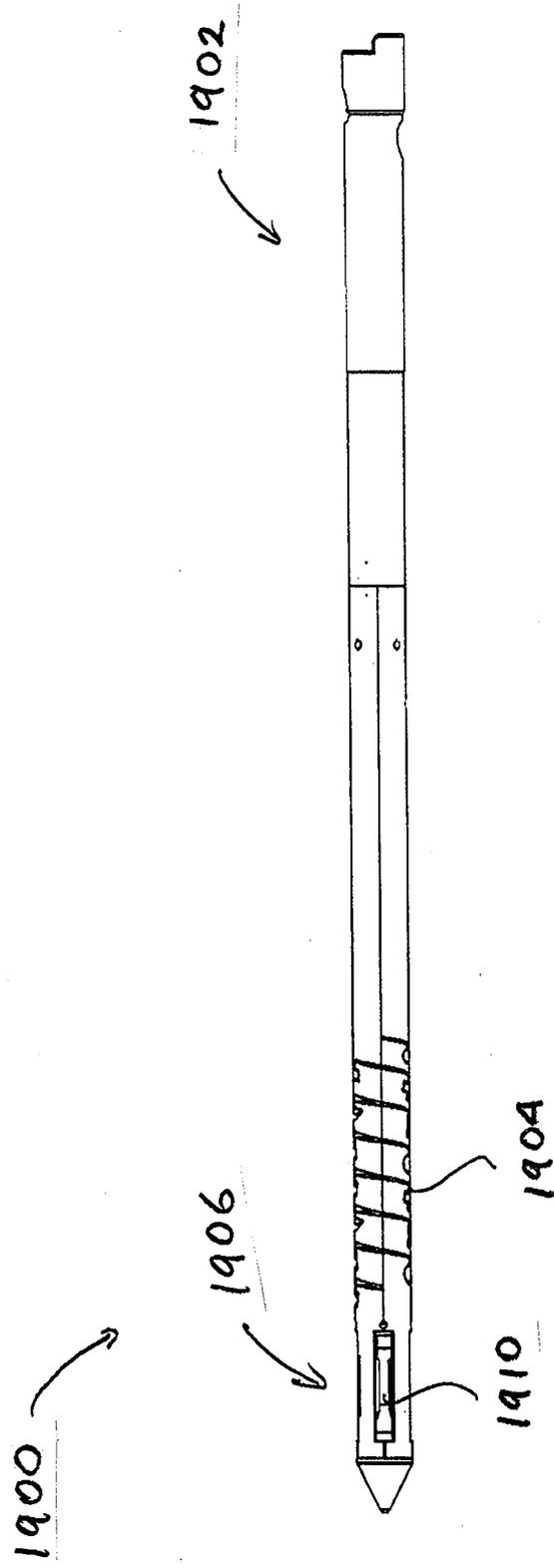

FIG. 36

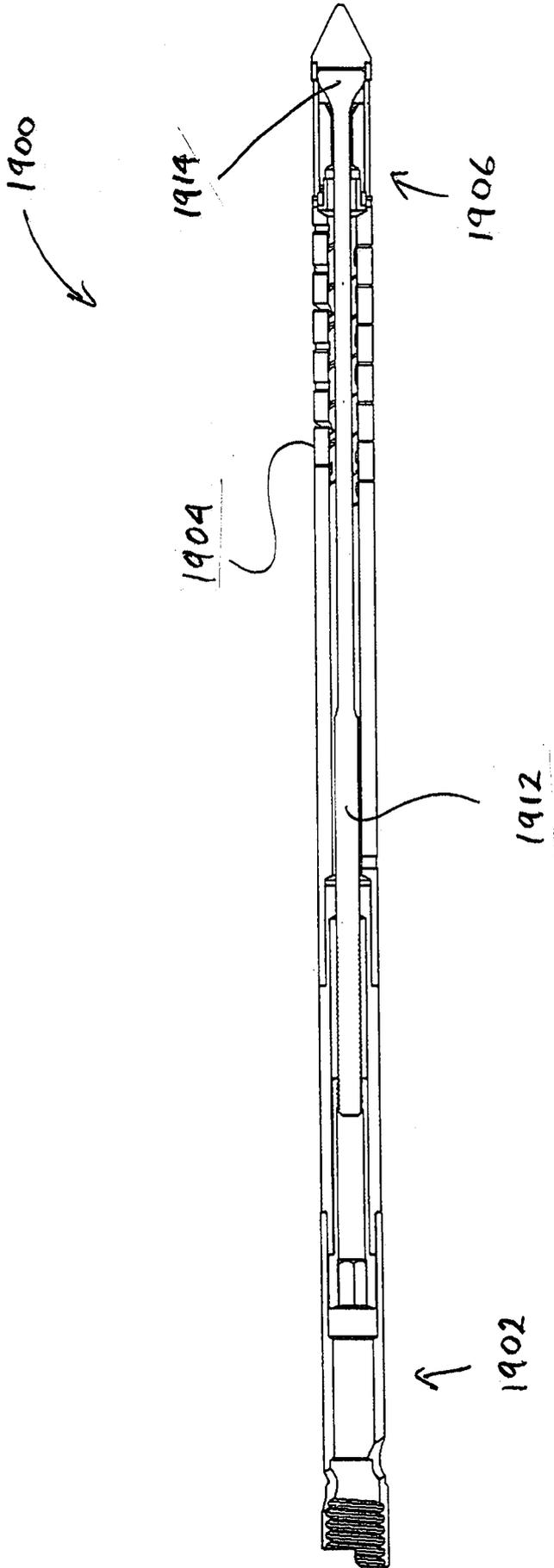

FIG. 37

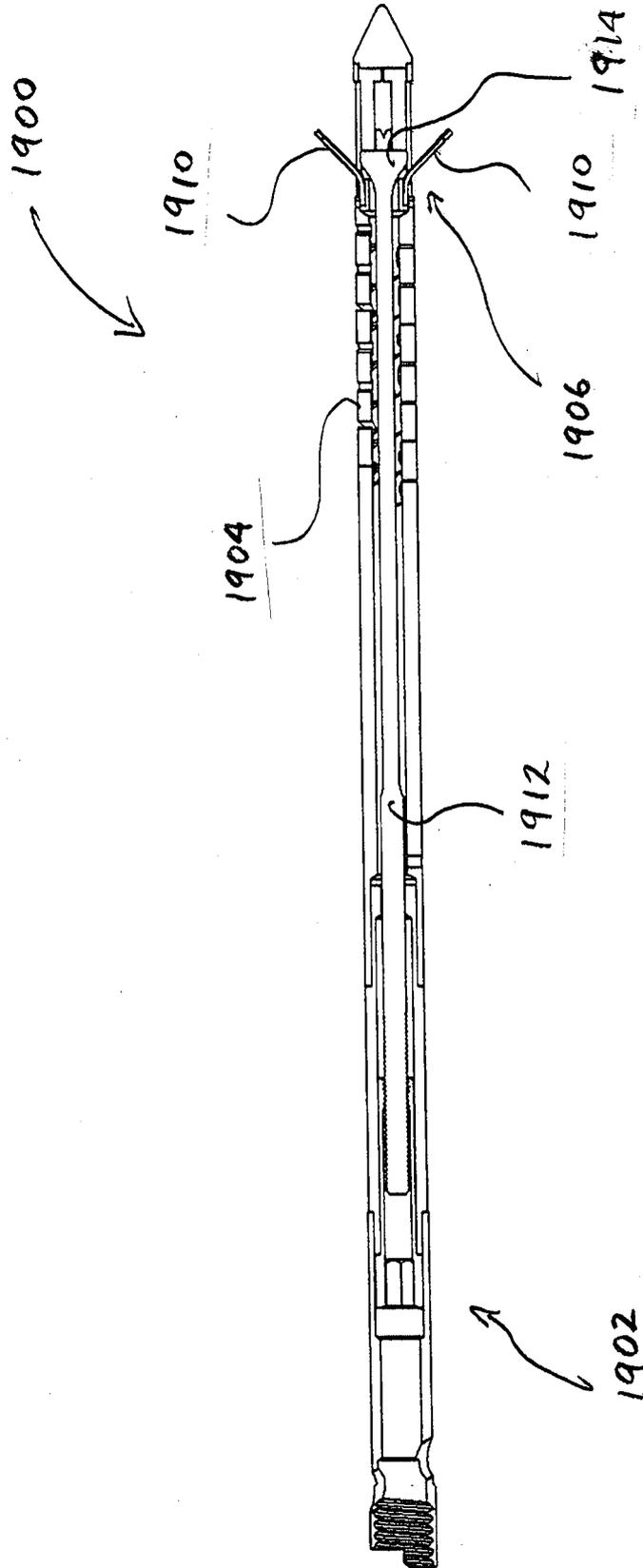

FIG. 38

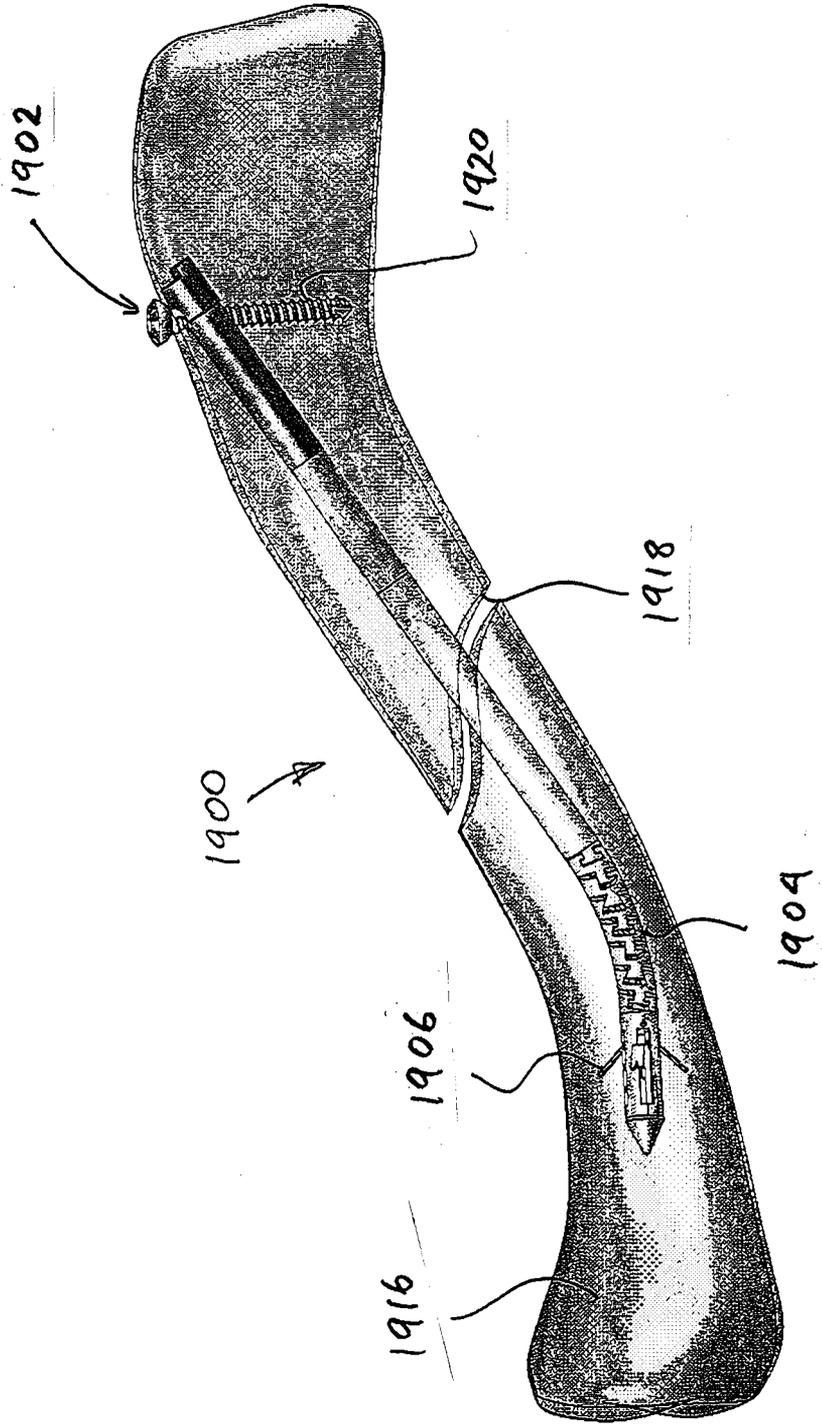

FIG. 39

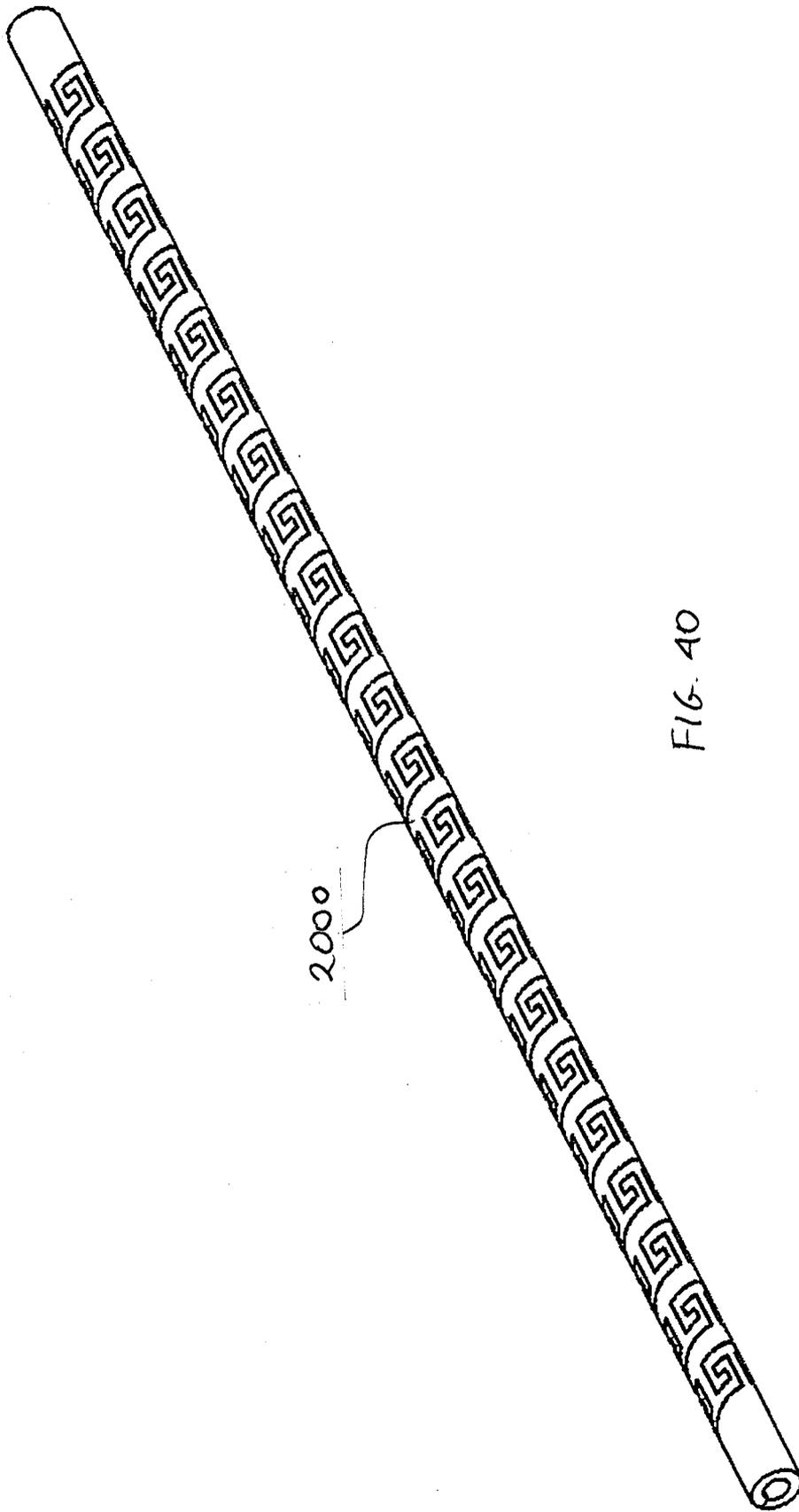
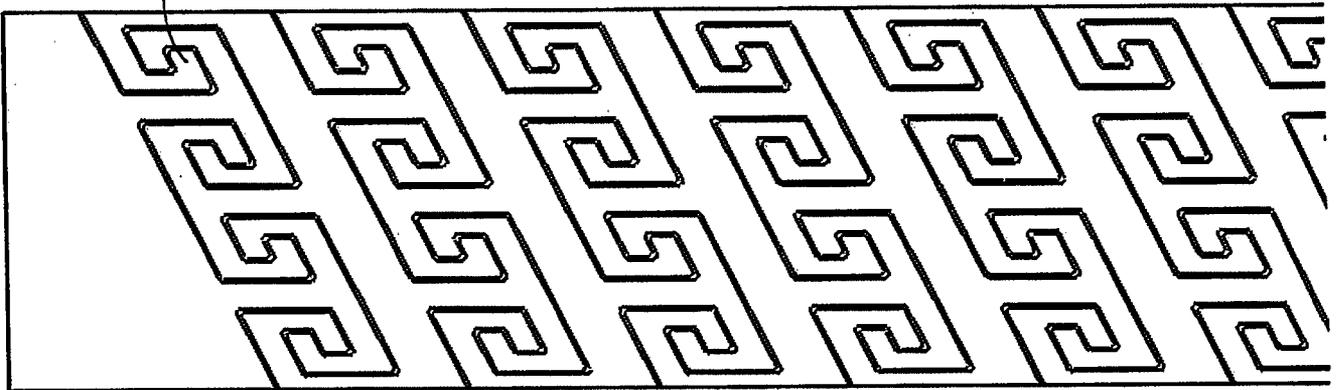

FIG. 40

2000

FIG. 41



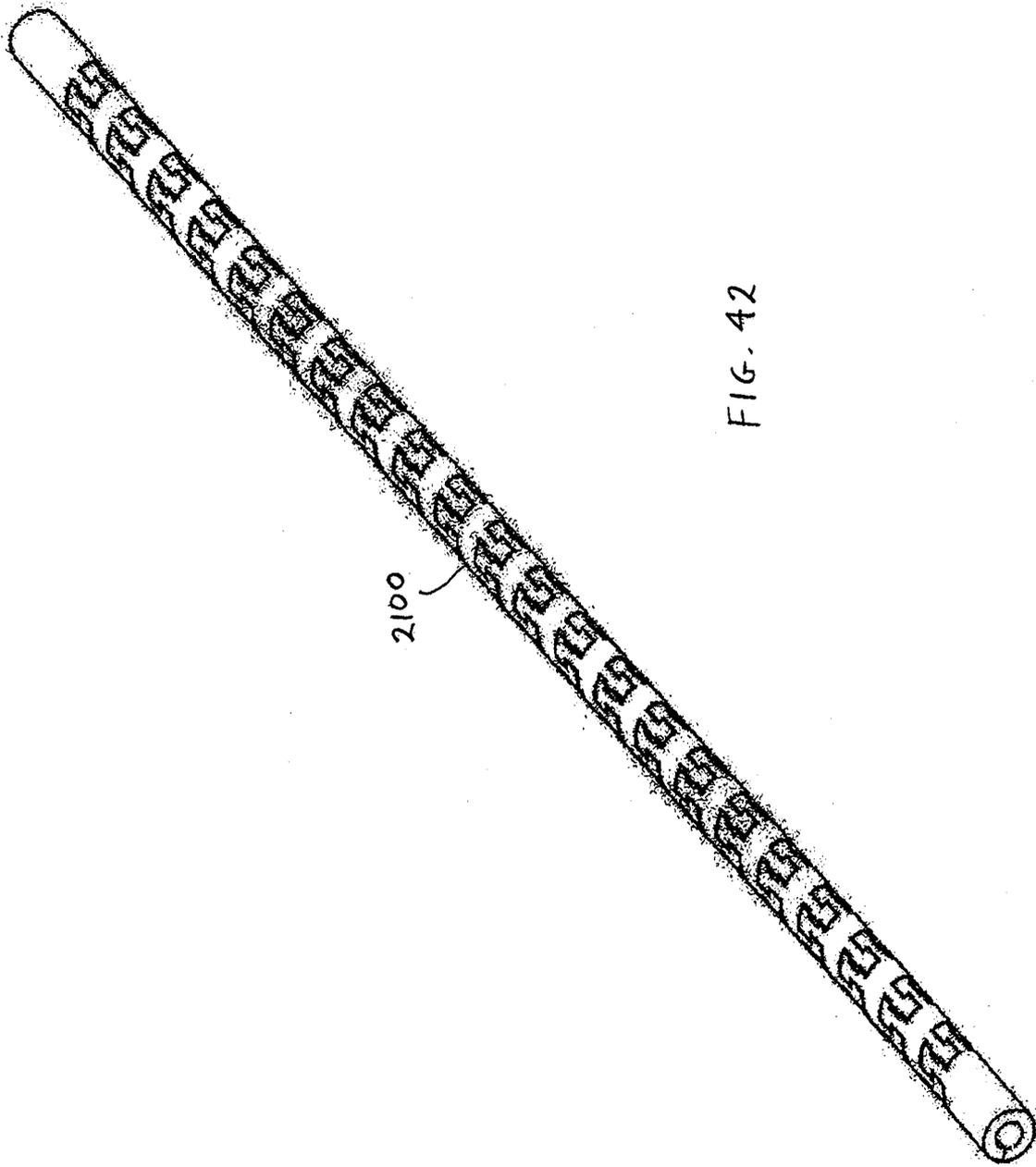

FIG. 42

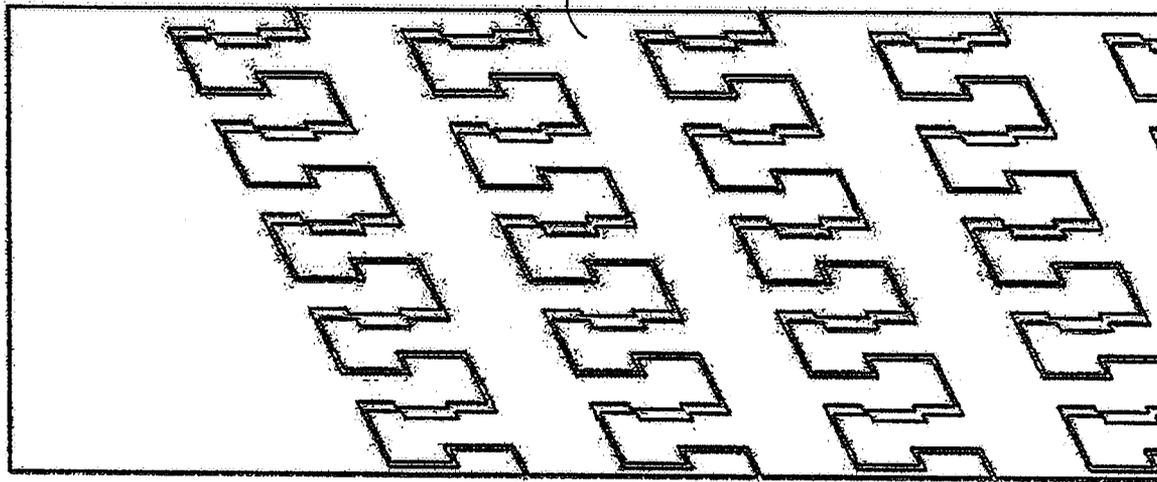
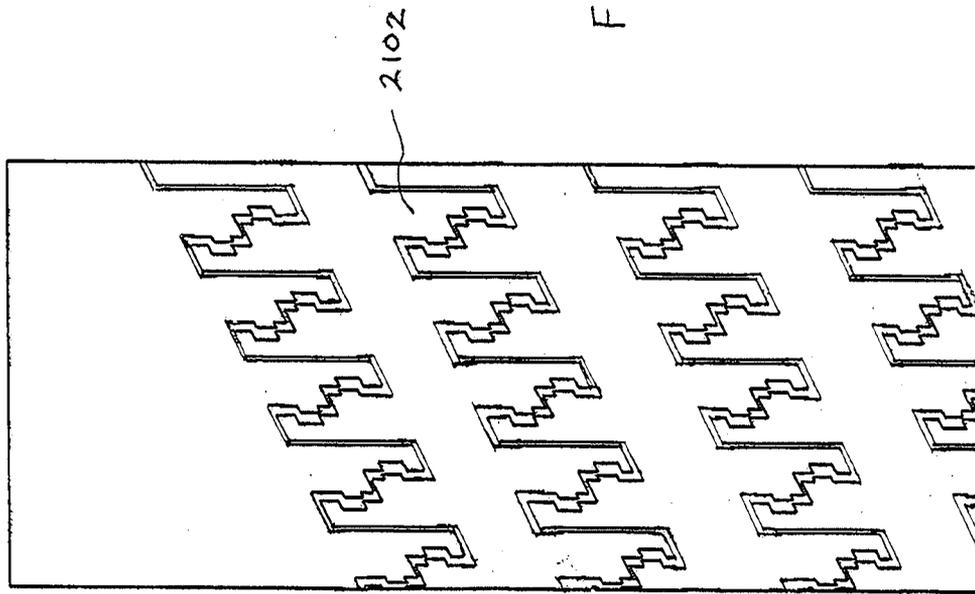

FIG. 43A

FIG. 43B



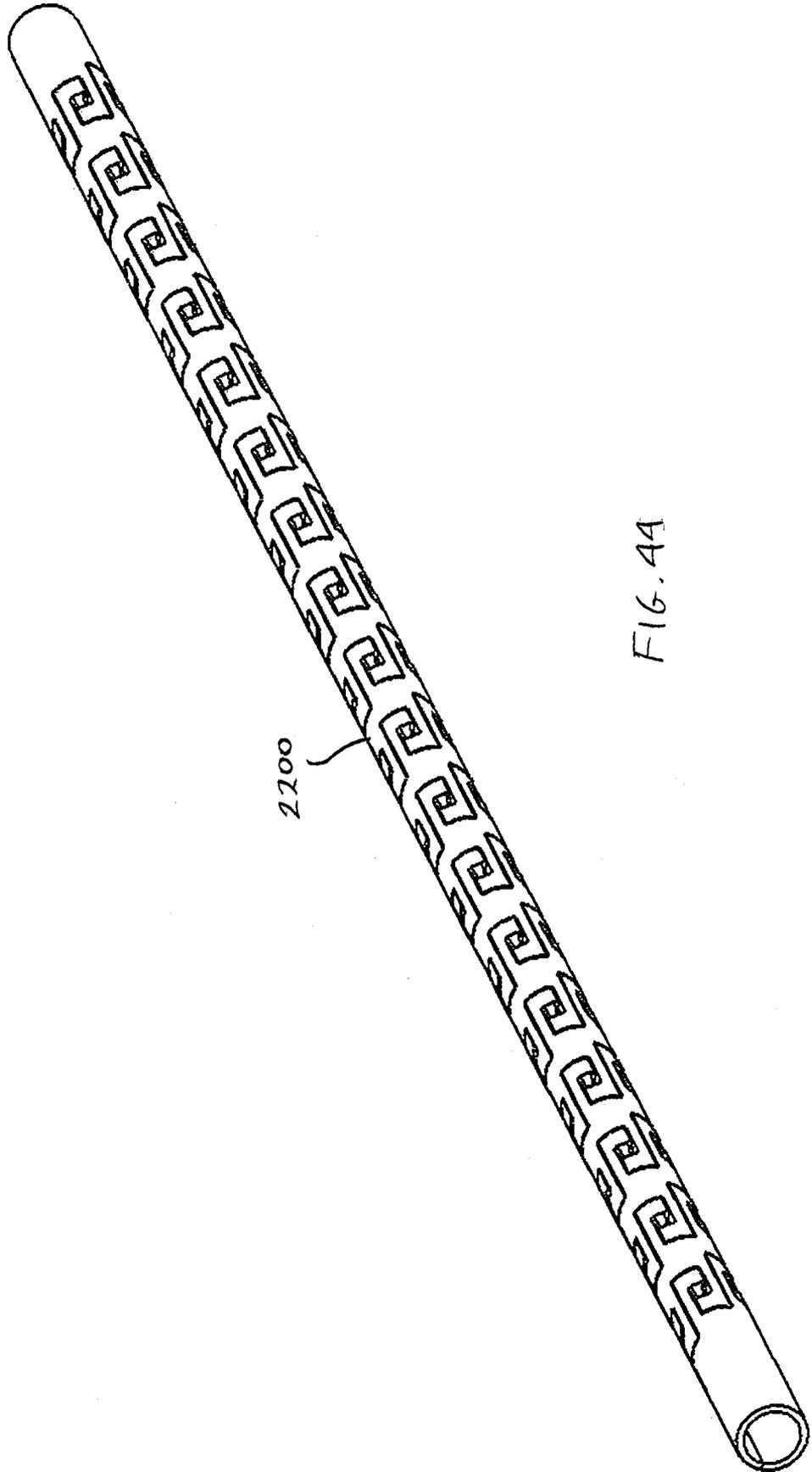
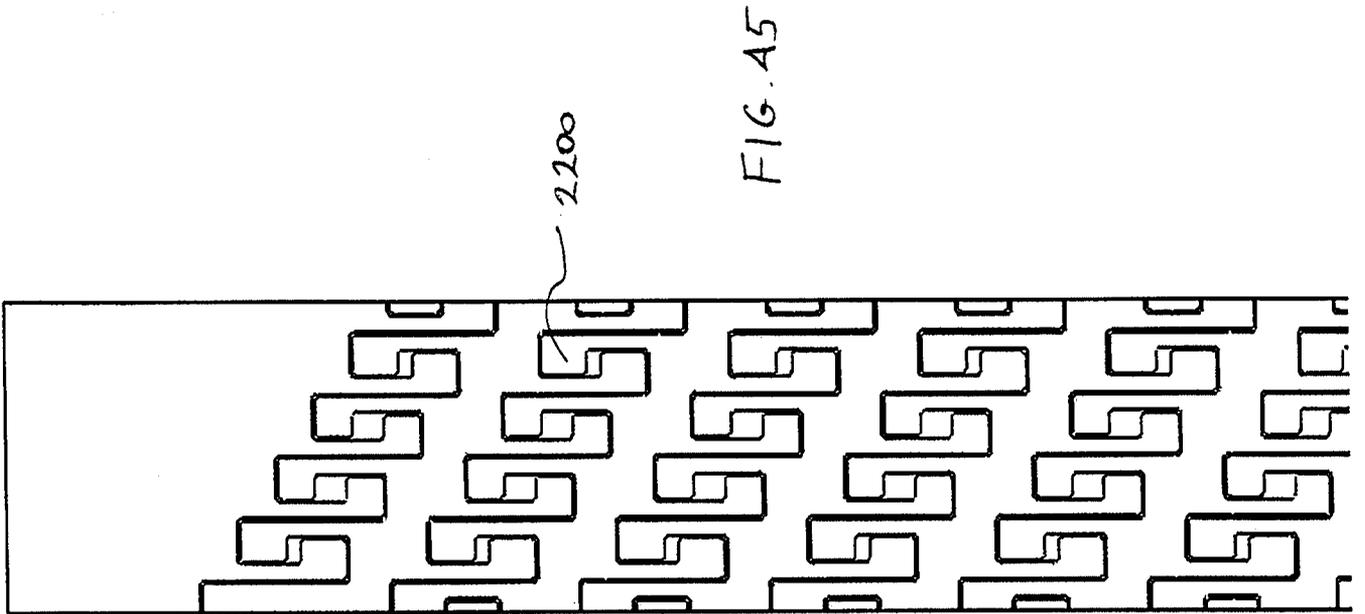

FIG. 4A



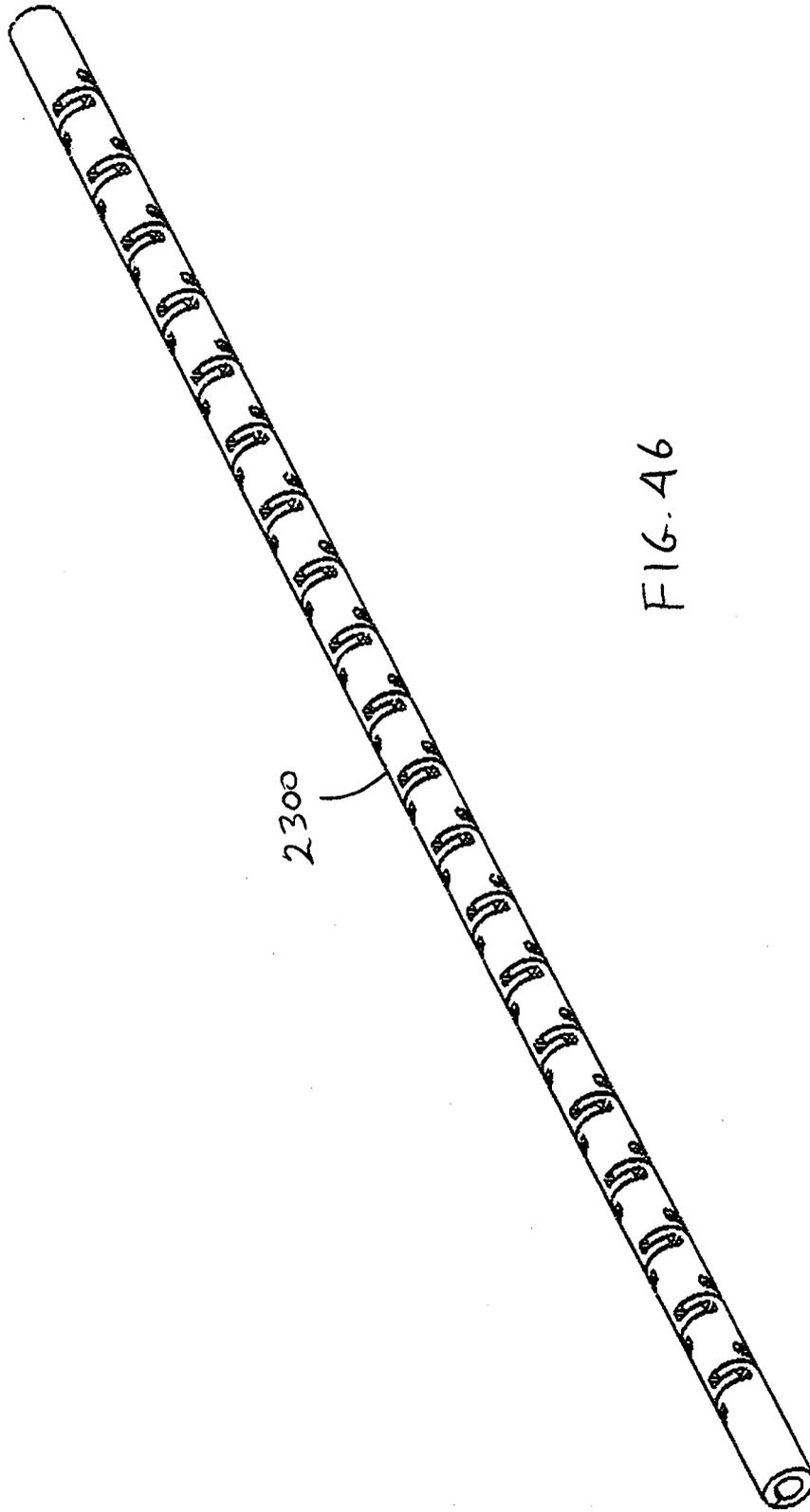
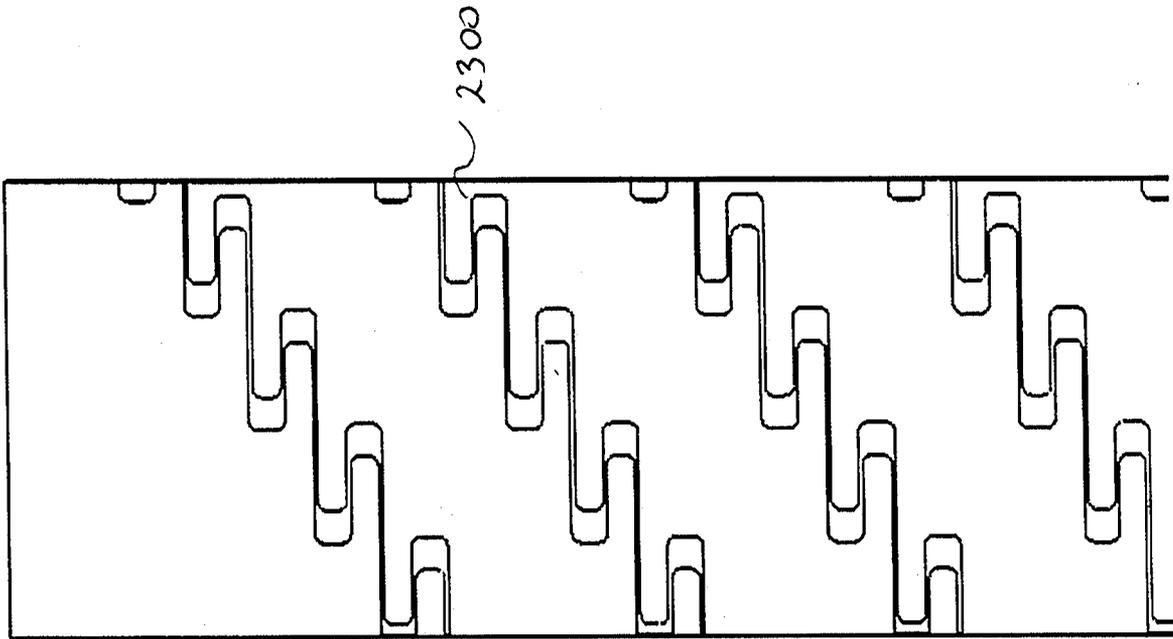

FIG. 46

FIG. 47



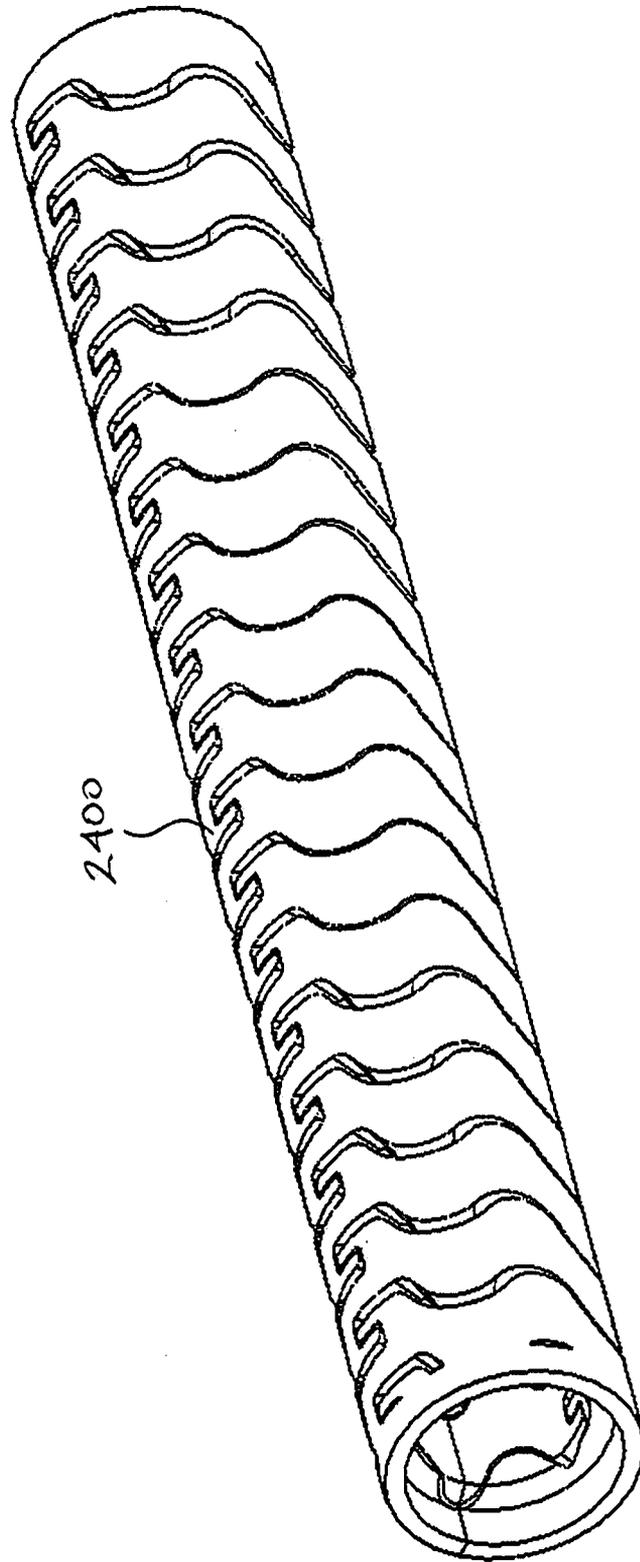

FIG. 48

FIG. 49

