

**(12) STANDARD PATENT APPLICATION (11) Application No. AU 2015200126 A1**  
**(19) AUSTRALIAN PATENT OFFICE**

(54) Title  
**Belt Pulling Exercise Apparatus**

(51) International Patent Classification(s)  
**A63B 23/00 (2006.01)**

(21) Application No: **2015200126** (22) Date of Filing: **2015.01.13**

(30) Priority Data

(31) Number	(32) Date	(33) Country
<b>201420170725.0</b>	<b>2014.04.10</b>	<b>CN</b>

(43) Publication Date: **2015.10.29**

(43) Publication Journal Date: **2015.10.29**

(71) Applicant(s)  
**Chung-Fu CHANG**

(72) Inventor(s)  
**CHANG, Chung-Fu**

(74) Agent / Attorney  
**A.P.T. Patent and Trade Mark Attorneys, PO Box 833, BLACKWOOD, SA, 5051**

ABSTRACT

A belt pulling exercise apparatus includes an adjusting belt, having a first ladder lock disposed thereon, and one end of the adjusting belt is passed through a first ring; two connecting belts, two first ends of the two connecting belts are fastened to the first ring simultaneously, two second ends of each connecting belts opposite to the first ends are respectively fastened to a third ring, and two second rings are respectively fastened to an upper surface of each connecting belt between the first end and the second end; two elastic rope assemblies, each elastic rope assembly is arranged corresponding to each connecting belt, and two ends of each elastic rope assembly are respectively connected to the second ring and the third ring of each corresponding connecting belt; and two hand grips, each hand grip is arranged at each corresponding connecting belt and each corresponding elastic rope assembly.

AUSTRALIA

---

*Patents Act 1990*

---

# COMPLETE SPECIFICATION

FOR A STANDARD PATENT  
ORIGINAL

---

## TO BE COMPLETED BY APPLICANT

**Name of Applicant:** Chung-Fu CHANG

**Actual Inventor(s):** Chung-Fu CHANG

**Address for Service:** A.P.T. Patent and Trade Mark Attorneys  
PO Box 833, Blackwood, SA 5051

**Invention Title:** Belt Pulling Exercise Apparatus

The following statement is a full description of this invention, including the best method of performing it known to me/us:-

## BELT PULLING EXERCISE APPARATUS

### FIELD OF THE INVENTION

[0001] The present invention relates to an exerciser, and more particularly to a belt pulling exercise apparatus.

### BACKGROUND OF THE INVENTION

[0002] Resistance exercise devices allow a user to exercise by providing a resistance to the movement of a user's arms, legs, or torso. Resistance is normally provided by working one muscle against another, or against gravity, and may include elastic bands to provide an increased resistance force. The usefulness of these devices depends, in part, on the ease with which a user can perform different types of exercises, the range or number of exercises that can be performed with the device, and the ease with which different users can adjust the device according to their height, weight, strength, and/or physical limitations.

[0003] Resistance exercise devices having elastic bands typically restrict the motion of a user's arms and/or legs, or the motion between the user and a support structure. Elastic exercise devices can be small, even portable, but have limited usefulness that result from their resistance characteristics, which depend on the length and elasticity of the elastic band. As a result of these characteristics, the elastic bands are useful for a specific length range, thus restricting the

diversity of exercises for which it can be used. In addition, it may not be possible for different users to use the same device for the same exercise due to differences in height, weight, or strength between different users. Thus, for an elastic device to be generally useful, such as to provide a complete workout or to allow for different users, a plurality of elastic bands are required that must be easily interchangeable. No known prior art device provides the ease of use necessary to be generally useful across a wide range of exercises.

[0004] Another limitation of elastic resistance exercise devices is that the resistance is inconsistent and increases with increasing displacement, and also tends to snap back when the user decreases his or her effort. While this resistance response provides for a compact design, it is problematic as it does not recreate the resistance encountered by muscles during more natural types of exercising, such as running, swimming, etc. Yet another limitation of elastic devices is the inability to support a wide range of weight of the user--typically the devices are adapted to support only the resistance provided by the user's muscles. This creates extreme limitations in the exercises that can be performed by any individual elastic device. For this reason, elastic devices must be used over a limited range of stances, further limiting the user's workout.

[0005] Another type of resistance exercise device provides an inelastic strap that is attachable to a fixed location such as, for example, a door. These devices may overcome some of the limitations of the elastic devices previously discussed by providing inelastic straps that can be anchored between a door and a doorjamb.

One of these devices has a fixed length strap attached to a door through a pulley system that allows the user to exercise by moving the arms in opposite directions. Another of these devices has a pair of fixed length straps anchored to a door. Both of these devices are of limited usefulness because of their fixed length and the range of exercises for which they can be used.

[0006] The recent pulling exerciser may reference to Taiwanese patents TWM468334, TWM433213, and TWM430293.

[0007] However, the above mentioned exerciser may be tie at one object, but it is easy to be released and dangerous for the user while being released unintentionally. The elasticity of pulling force cannot be adjusted or modified. And the length of belt or band cannot be adjusted based on the height of the user or the distance between the user and the fastening point.

## 15 SUMMARY OF THE INVENTION

[0008] An objective of this invention is providing a belt pulling exercise apparatus. It may be easily adjusting or modifying the elasticity of pulling force, and further fastened between a wall and a door and adjusting the length of the adjusting belt, and further adjusting the distance between force point of the adjusting belt and the door or the wall by using the first ring or the second ring. In addition, it may be also fastened at a transverse rod to exercise. Therefore, it is easy for operation, has simplified structure, and easy to carry.

[0009] To achieve above objectives, a c belt pulling exercise apparatus is provided. The belt pulling exercise apparatus includes an adjusting belt, having a first ladder lock disposed thereon, and one end of the adjusting belt is passed through a first ring; two  
5 connecting belts, two first ends of the two connecting belts are fastened to the first ring simultaneously, two second ends of each connecting belts opposite to the first ends are respectively fastened to a third ring, and two second rings are respectively fastened to an upper surface of each connecting belt between the first end and the  
10 second end; two elastic rope assemblies, each elastic rope assembly is arranged corresponding to each connecting belt, and two ends of each elastic rope assembly are respectively connected to the second ring and the third ring of each corresponding connecting belt; and two hand grips, each hand grip is arranged at each corresponding  
15 connecting belt and each corresponding elastic rope assembly.

[0010] Wherein each hand grip is connected to the second end of each corresponding connecting belt opposite to the first ring while in a fastening status; each hand grp is detachably connected to one end of each corresponding elastic rope assembly opposite to the second  
20 ring and the second end of each connecting belt is turned back and then connected to the first ring while in an elastic status.

[0011] In some embodiments, one end of the adjusting belt is fastened to a second ladder lock, and the other end of the adjusting belt is passed through the first ring, turned back to itself, passed  
25 through the first ladder lock, and then fastened to itself.

[0012] In some embodiments, one end of the adjusting belt is fastened to a buckle, and the other end of the adjusting belt is passed through the first ring and the first ladder lock, and then detachably locked at the buckle.

5 [0013] In some embodiments, the adjusting belt is passed through between a door and a wall, the first ring or the second ring is arranged at the same side of the wall and the door, an upper portion of the first ring or the second ring is against the wall through the adjusting belt to adjust the distance between the adjusting belt and  
10 the door by using the first ring or the second ring.

[0014] In some embodiments, the adjusting belt is passed through between a door and a wall, the first ladder lock is arranged at the same side of the wall and the door, an upper portion of the first ladder lock is against the wall through the adjusting belt, or the  
15 adjusting belt is surrounding and tightening a transverse rod and then locked by the buckle.

[0015] In some embodiments, each third ring is connected to a first clasp for detachable connection, and each connecting belt is detachably connected to each corresponding hand grip through each  
20 corresponding first clasp.

[0016] In some embodiments, each elastic rope assembly includes at least two elastic ropes.

[0017] In some embodiments, each elastic rope has an elastic body, a



second clasp, and a third clasp, the second clasp and the third clasp are respectively disposed at two ends of the elastic body, the second clasp is detachably connected to the corresponding second ring, and the third clasp is detachably connected to the corresponding hand grip.

[0018] Further features and advantages of the present invention will become apparent to those of skill in the art in view of the detailed description of preferred embodiments which follows, when considered together with the attached drawings and claims.

#### BRIEF DESCRIPTION OF THE DRAWINGS

[0019] All the objects, advantages, and novel features of the invention will become more apparent from the following detailed descriptions when taken in conjunction with the accompanying drawings.

[0020] FIG. 1 is an exploded view of a belt pulling exercise apparatus according to this present invention.

[0021] FIG. 2 is an outside view of the belt pulling exercise apparatus according to this present invention.

[0022] FIG. 3 is a view of the belt pulling exercise apparatus according to this present invention when the adjusting belt is passed through between a door and a wall with a second ladder lock.

[0023] FIG. 4 is a view of the belt pulling exercise apparatus

according to this present invention when the adjusting belt is passed through between a door and a wall with a first ladder lock.

[0024] FIG. 5 is a partial view of the belt pulling exercise apparatus according to this present invention while in a fastening status.

5 [0025] FIG. 6 is a partial view of the belt pulling exercise apparatus according to this present invention while in an elastic status.

[0026] FIG. 7 is an operational view of the belt pulling exercise apparatus according to this present invention when adjusting the number of the elastic ropes of the elastic rope assemblies to modify  
10 elasticity of pulling force.

[0027] FIG. 8 is an operational view of the belt pulling exercise apparatus according to this present invention while in the fastening status and being fastened between the door and the wall by the first ladder lock.

15 [0028] FIG. 9 is a partial view of the belt pulling exercise apparatus according to this present invention while in the fastening status and being fastened between the door and the wall by the second ladder lock.

[0029] FIG. 10 is an operational view of the belt pulling exercise  
20 apparatus according to this present invention while in the elastic status and being fastened between the door and the wall by the first ladder lock.

[0030] FIGs. 11 and 12 are operational views of the belt pulling exercise apparatus according to this present invention while in the elastic status and being fastened between the door and the wall by the first ladder lock.

5 [0031] FIG. 13 is an exploded view of one another embodiment of the belt pulling exercise apparatus according to this present invention.

[0032] FIG. 14 is an outside view of the another embodiment of the belt pulling exercise apparatus according to this present invention.

10 **DESCRIPTION OF THE PREFERRED EMBODIMENT**

[0033] Referring now to the drawings where like characteristics and features among the various figures are denoted by like reference characters.

15 [0034] FIG. 1 is an exploded view of a belt pulling exercise apparatus according to this present invention. FIG. 2 is an outside view of the belt pulling exercise apparatus according to this present invention. FIG. 3 is a view of the belt pulling exercise apparatus according to this present invention when the adjusting belt is passed through between a door and a wall with a second ladder lock. FIG. 4  
20 is a view of the belt pulling exercise apparatus according to this present invention when the adjusting belt is passed through between a door and a wall with a first ladder lock. FIG. 5 is a partial view of the belt pulling exercise apparatus according to this present

invention while in a fastening status. FIG. 6 is a partial view of the belt pulling exercise apparatus according to this present invention while in an elastic status. FIG. 7 is an operational view of the belt pulling exercise apparatus according to this present invention when  
5 adjusting the number of the elastic ropes of the elastic rope assemblies to modify elasticity of pulling force. FIG. 8 is an operational view of the belt pulling exercise apparatus according to this present invention while in the fastening status and being fastened between the door and the wall by the first ladder lock. FIG.  
10 9 is a partial view of the belt pulling exercise apparatus according to this present invention while in the fastening status and being fastened between the door and the wall by the second ladder lock. FIG. 10 is an operational view of the belt pulling exercise apparatus according to this present invention while in the elastic status and  
15 being fastened between the door and the wall by the first ladder lock. FIGS. 11 and 12 are operational views of the belt pulling exercise apparatus according to this present invention while in the elastic status and being fastened between the door and the wall by the first ladder lock.

20 [0035] Please refer to FIGs. 1 to 12, the belt pulling exercise apparatus 100 of this invention may comprise an adjusting belt 1, two connecting belts 2, two elastic rope assemblies 3, and two hand grips 4.

[0036] The adjusting belt 1 may have a first ladder lock 12 disposed  
25 thereon, and one end of the adjusting belt 1 is passed through a first ring 21. That is, one end of the adjusting belt 1 may be fastened to a

second ladder lock 11, and the other end of the adjusting belt 1 may be passed through the first ring 21, turned back to itself, passed through the first ladder lock 12, and then fastened to itself.

5 [0037] Two first ends of the two connecting belts 2 may be fastened to the first ring 21 simultaneously, two second ends of each connecting belts 2 opposite to the first ends are respectively fastened to a third ring 23, and two second rings 22 may be respectively fastened to an upper surface of each connecting belt 2 between the first end and the second end.

10 [0038] In addition, the adjusting belt 1 may be passed through between a door 200 and a wall 300. The first ring 21 or the second ring 22 may be arranged at the same side of the wall 300 and the door 200. An upper portion of the first ring 21 or the second ring 22 may be against the wall 300 through the adjusting belt 1 to adjust the  
15 length of the adjusting belt 1 and further adjusting the distance between force point of the adjusting belt 1 and the door 200 or the wall 300 by using the first ring 21 or the second ring 22 (shown as in FIGs. 9 and 10).

20 [0039] Each third ring 23 may be connected to a first clasp 24 for detachable connection, and each connecting belt 2 may be detachably connected to each corresponding hand grip 4 through each corresponding first clasp 24.

[0040] Each elastic rope assembly 3 may be arranged corresponding to each connecting belt 2. Two ends of each elastic rope assembly 3

may be respectively connected to the second ring 22 and the third ring 23 of each corresponding connecting belt 2. Each elastic rope assembly 3 may include at least two elastic ropes 30. This invention shows three elastic ropes for illustrations, but not limited thereto.

5 [0041] Each elastic rope 30 may have an elastic body 31, a second clasp 32, and a third clasp 33. The second clasp 32 and the third clasp 33 may be respectively disposed at two ends of the elastic body 31. The second clasp 32 may be detachably connected to the corresponding second ring 22, and the third clasp 33 may be  
10 detachably connected to the corresponding hand grip 4.

[0042] If a user wants to modify the elasticity of pulling force, he/she may disassemble the third clasp 33 of one or two elastic rope 30 from corresponding hand grip 4 and then connect to corresponding second ring 22 of the connecting belt 2 so as to modify  
15 the magnitude of pulling force and further to achieve the effectiveness of adapting to various stretching exercises (shown as in FIGs. 10 to 12).

[0043] Each hand grip 4 may be arranged at each corresponding connecting belt 2 and each corresponding elastic rope assembly 3.

20 [0044] Therefore, when in a fastening status, one end of each hand grip 4 is connected to one end of the corresponding connecting belt 2 opposite to the first ring 21. When in an elastic status, the end of each hand grip 4 is detachably connected to the end of corresponding elastic rope assembly 3 opposite to the second ring 22 and the end of

the connecting belt 2 opposite to the first ring 21 is rolled up and locked at the first ring 21.

[0045] That is, each hand grip 4 is connected to the second end of each corresponding connecting belt 2 opposite to the first ring 21 while in the fastening status. Each hand grip 4 is detachably connected to one end of each corresponding elastic rope assembly 3 opposite to the second ring 22 and the second end of each connecting belt 2 is turned back and then connected to the first ring 21 while in the elastic status.

[0046] FIG. 13 is an exploded view of one another embodiment of the belt pulling exercise apparatus according to this present invention. FIG. 14 is an outside view of the another embodiment of the belt pulling exercise apparatus according to this present invention.

[0047] Please refer to FIGs. 13 and 14, one end of the adjusting belt 1 may be fastened to a buckle 11', and the other end of the adjusting belt 1 may be passed through the first ring 21 and the first ladder lock 12 and then detachably locked at the buckle 11'.

[0048] The adjusting belt 1 may be passed through between the door 200 and the wall 300. The first ladder lock 11 may be arranged at the same side of the wall 300 and the door 200. An upper portion of the first ladder lock 12 may be against the wall 300 through the adjusting belt 1, or the adjusting belt 1 may be surrounding and tightening a transverse rod 400 and then locked by the buckle 11'.

What is claimed is:

1. A belt pulling exercise apparatus, comprising:

5 an adjusting belt, having a first ladder lock disposed thereon,  
and one end of the adjusting belt is passed through a first  
ring;

10 two connecting belts, two first ends of the two connecting  
belts are fastened to the first ring simultaneously, two  
second ends of each connecting belts opposite to the first  
ends are respectively fastened to a third ring, and two  
second rings are respectively fastened to an upper surface  
of each connecting belt between the first end and the  
second end;

15 two elastic rope assemblies, each elastic rope assembly is  
arranged corresponding to each connecting belt, and two  
ends of each elastic rope assembly are respectively  
connected to the second ring and the third ring of each  
corresponding connecting belt; and

20 two hand grips, each hand grip is arranged at each  
corresponding connecting belt and each corresponding  
elastic rope assembly;

wherein each hand grip is connected to the second end of



each corresponding connecting belt opposite to the first ring while in a fixing condition; each hand grp is detachably connected to one end of each corresponding elastic rope assembly opposite to the second ring and the second end of each connecting belt is turned back and then connected to the first ring while in an elastic condition.

- 5 2. The belt pulling exercise apparatus as claimed in claim 1, wherein one end of the adjusting belt is fastened to a second ladder lock, the other end of the adjusting belt is passed through the first ring,  
10 turned back to itself, passed through the first ladder lock, and then fastened to itself.
- 15 3. The belt pulling exercise apparatus as claimed in claim 1, wherein one end of the adjusting belt is fastened to a buckle, and the other end of the adjusting belt is passed through the first ring and the first ladder lock, and then detachably locked at the buckle.
- 20 4. The belt pulling exercise apparatus as claimed in claim 2, wherein the adjusting belt is passed through between a door and a wall, the first ring or the second ring is arranged at the same side of the wall and the door, an upper portion of the first ring or the second ring is against the wall through the adjusting belt to adjust the distance between the adjusting belt and the door by using the first ring or the second ring.
5. The belt pulling exercise apparatus as claimed in claim 3, wherein the adjusting belt is passed through between a door and a wall,

the first ladder lock is arranged at the same side of the wall and the door, an upper portion of the first ladder lock is against the wall through the adjusting belt, or the adjusting belt is surrounding and tightening a transverse rod and then locked by the buckle.

5

6. The belt pulling exercise apparatus as claimed in claim 1, wherein each third ring is connected to a first clasp for detachable connection, and each connecting belt is detachably connected to each corresponding hand grip through each corresponding first clasp.

10

7. The belt pulling exercise apparatus as claimed in claim 2, wherein each third ring is connected to a first clasp for detachable connection, and each connecting belt is detachably connected to each corresponding hand grip through each corresponding first clasp.

15

8. The belt pulling exercise apparatus as claimed in claim 1, wherein each elastic rope assembly includes at least two elastic ropes.

9. The belt pulling exercise apparatus as claimed in claim 2, wherein each elastic rope assembly includes at least two elastic ropes.

20 10. The belt pulling exercise apparatus as claimed in claim 8, wherein each elastic rope has an elastic body, a second clasp, and a third clasp, the second clasp and the third clasp are respectively disposed at two ends of the elastic body, the second clasp is

detachably connected to the corresponding second ring, and the third clasp is detachably connected to the corresponding hand grip.

11. The belt pulling exercise apparatus as claimed in claim 9, wherein  
5 each elastic rope has an elastic body, a second clasp, and a third clasp, the second clasp and the third clasp are respectively disposed at two ends of the elastic body, the second clasp is detachably connected to the corresponding second ring, and the third clasp is detachably connected to the corresponding hand  
10 grip.

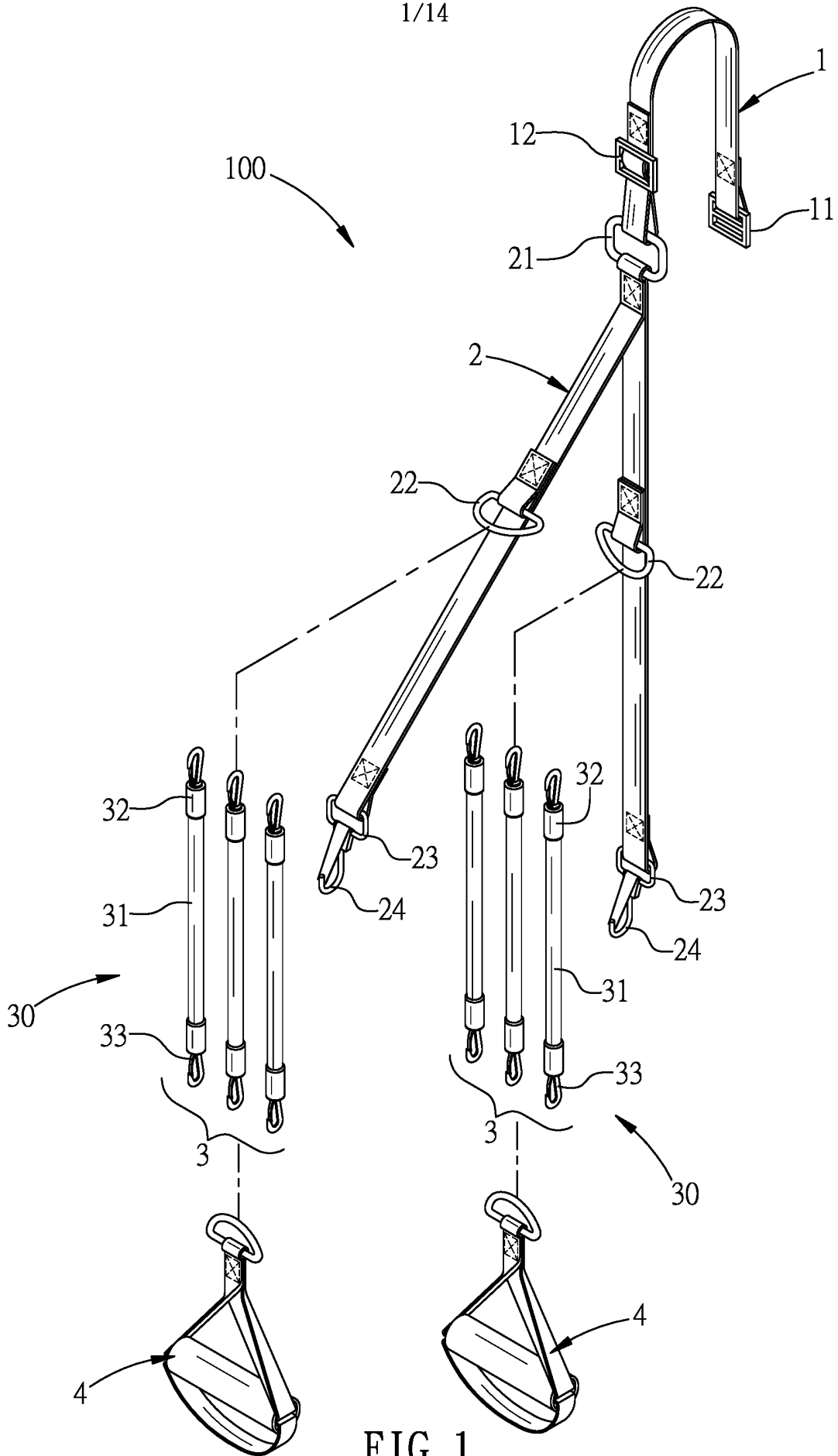



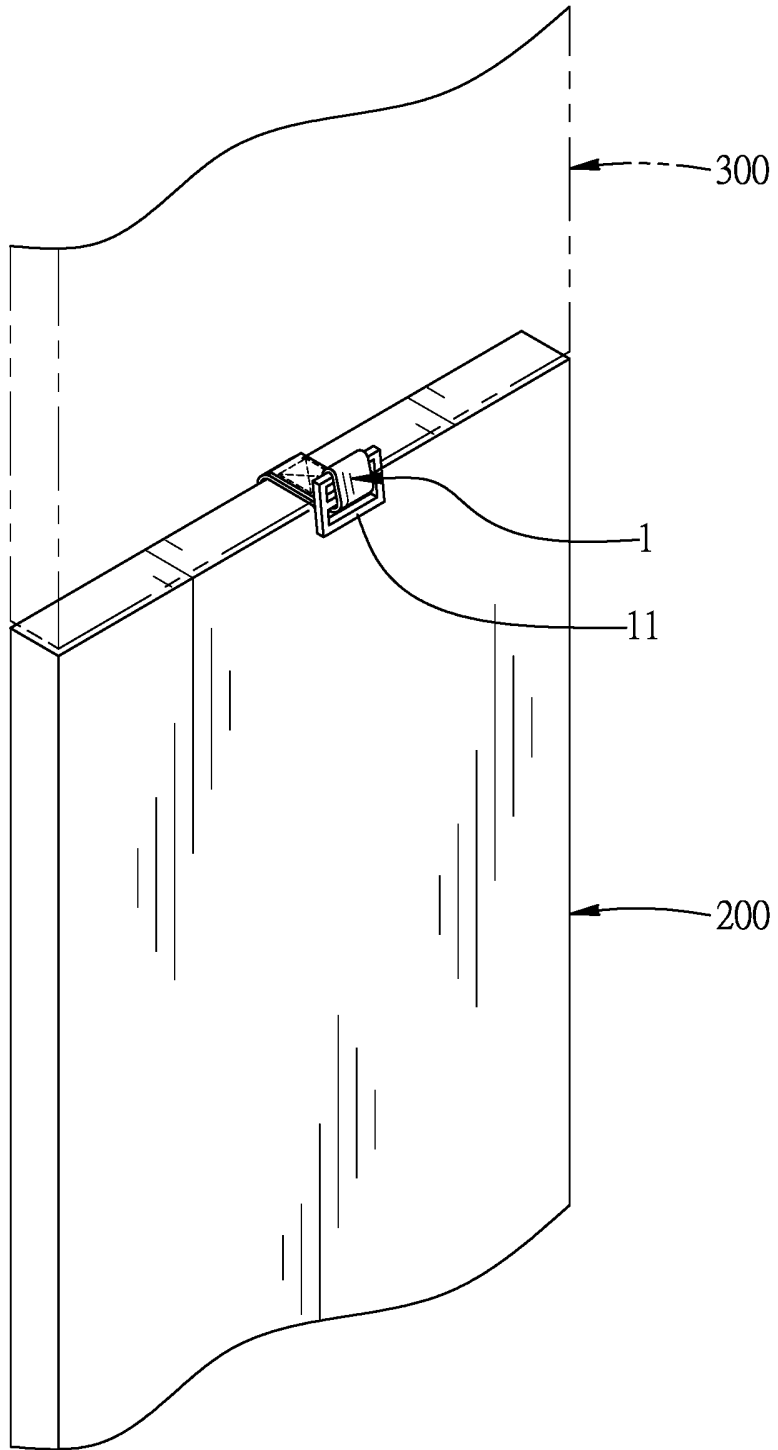

FIG. 3

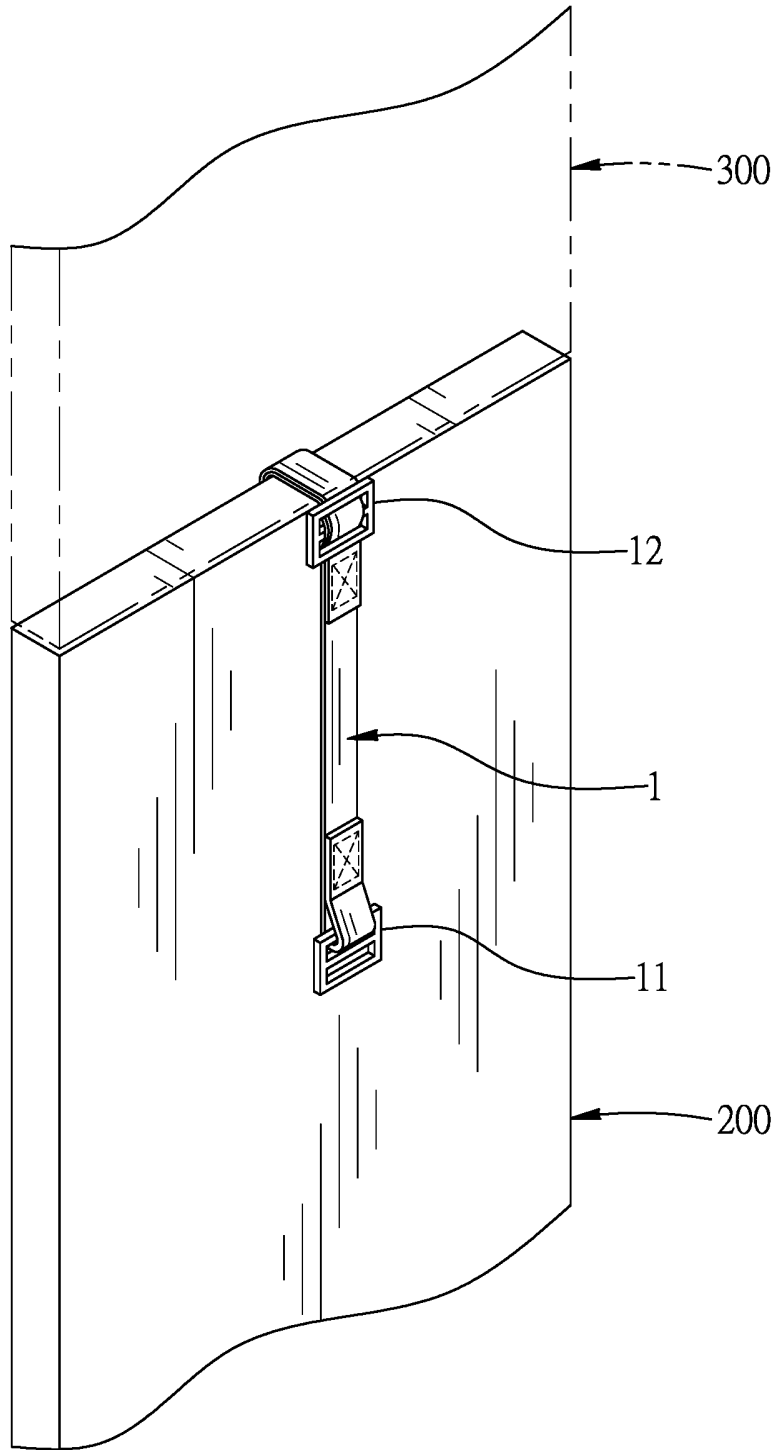

FIG. 4

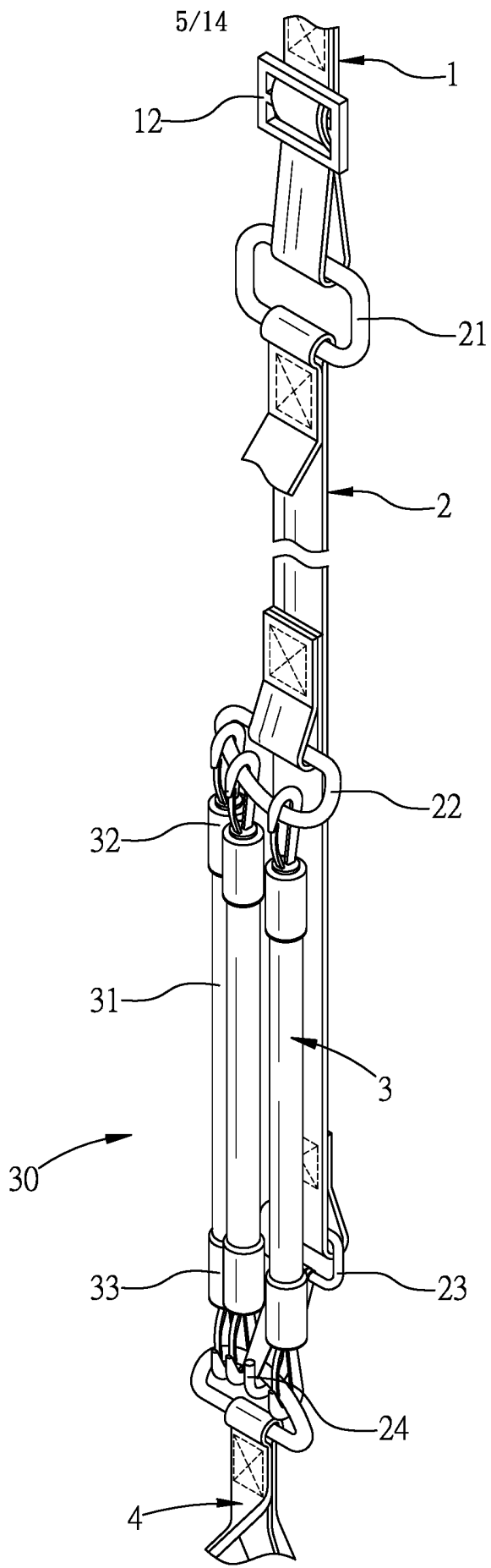

FIG. 5



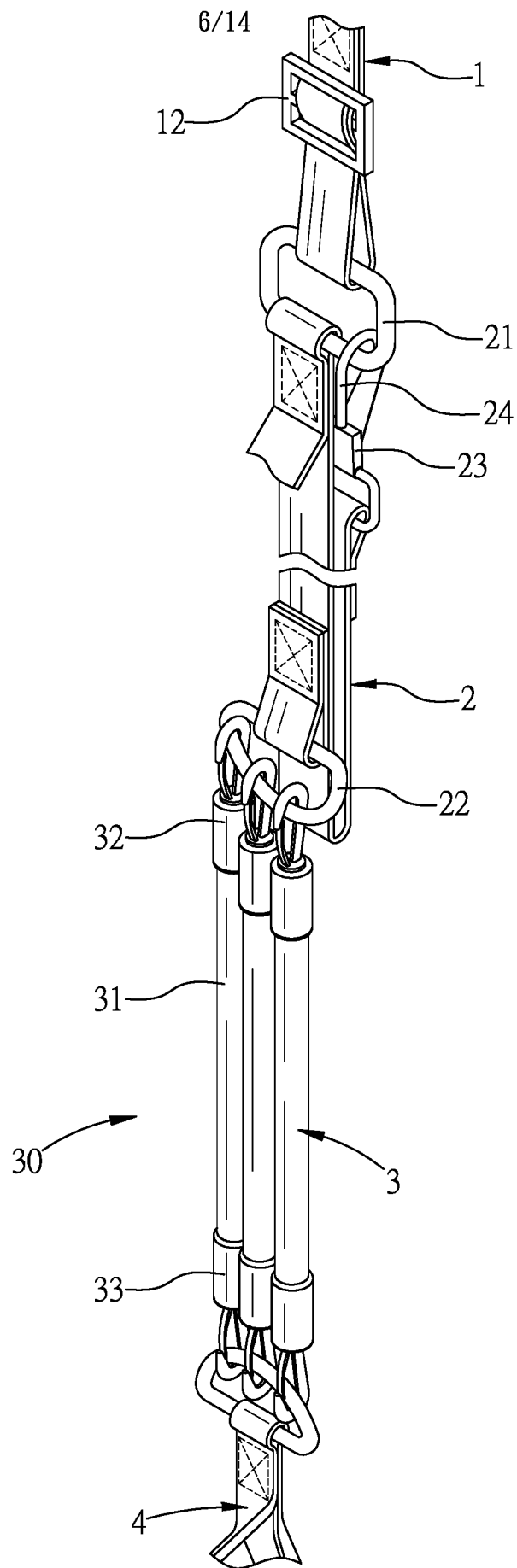

FIG. 6

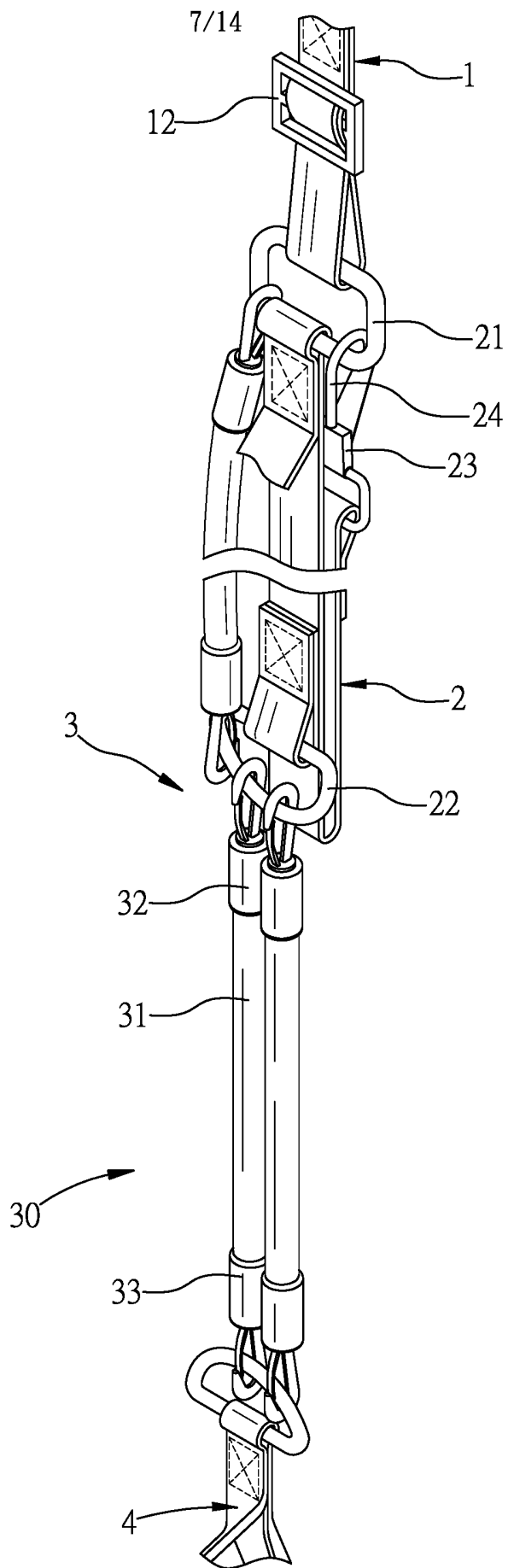

FIG. 7

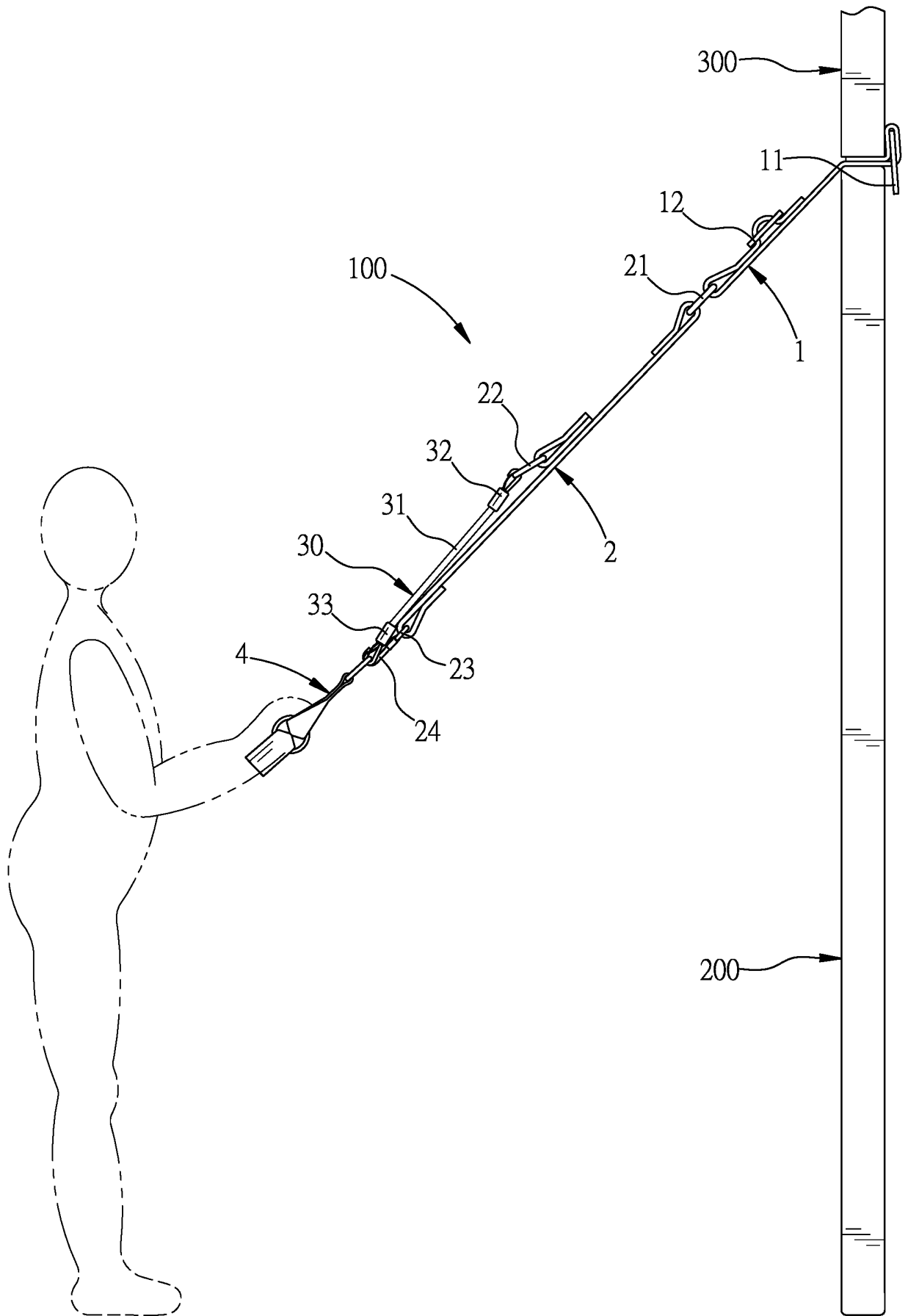

FIG. 8

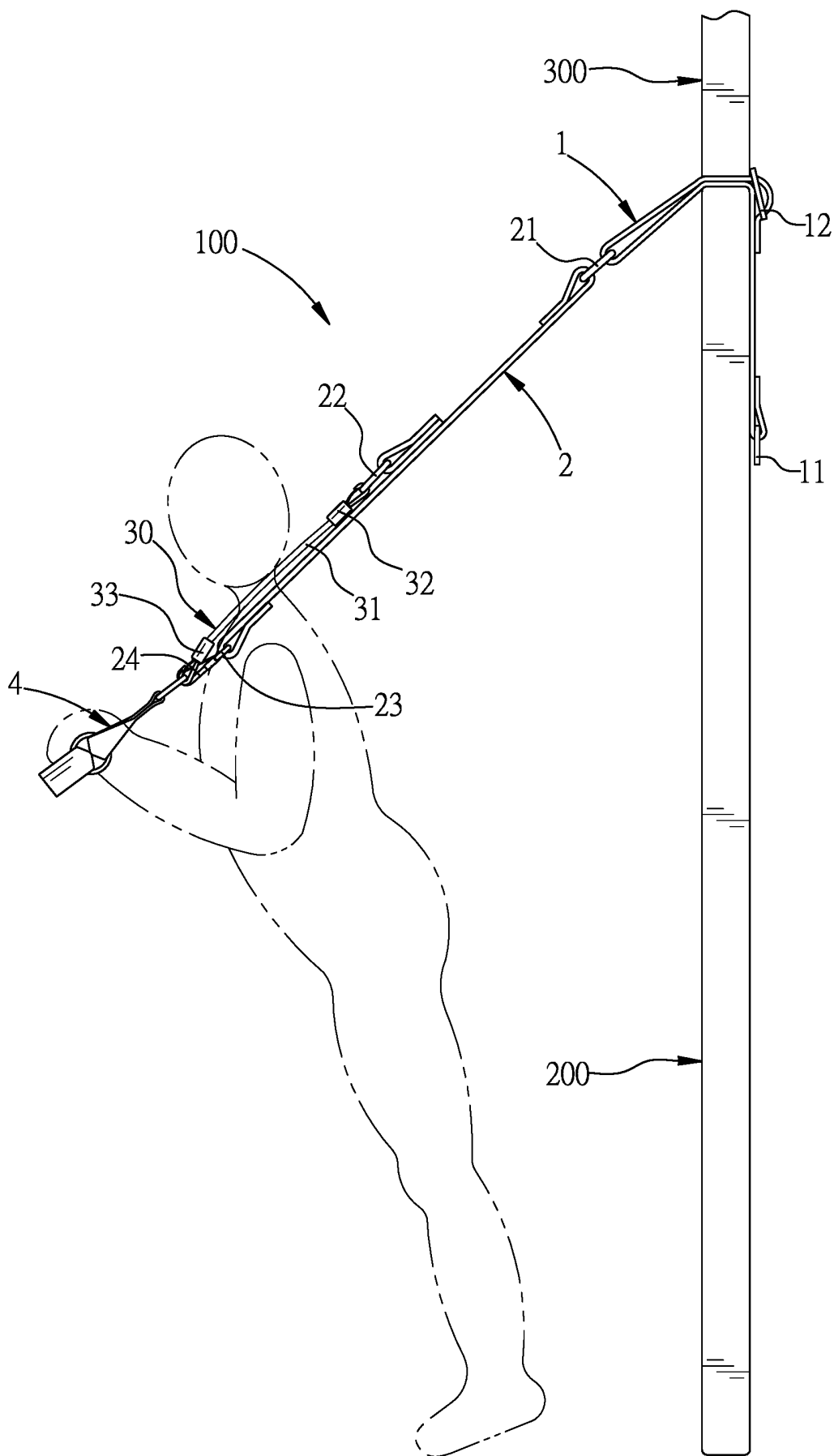

FIG. 9

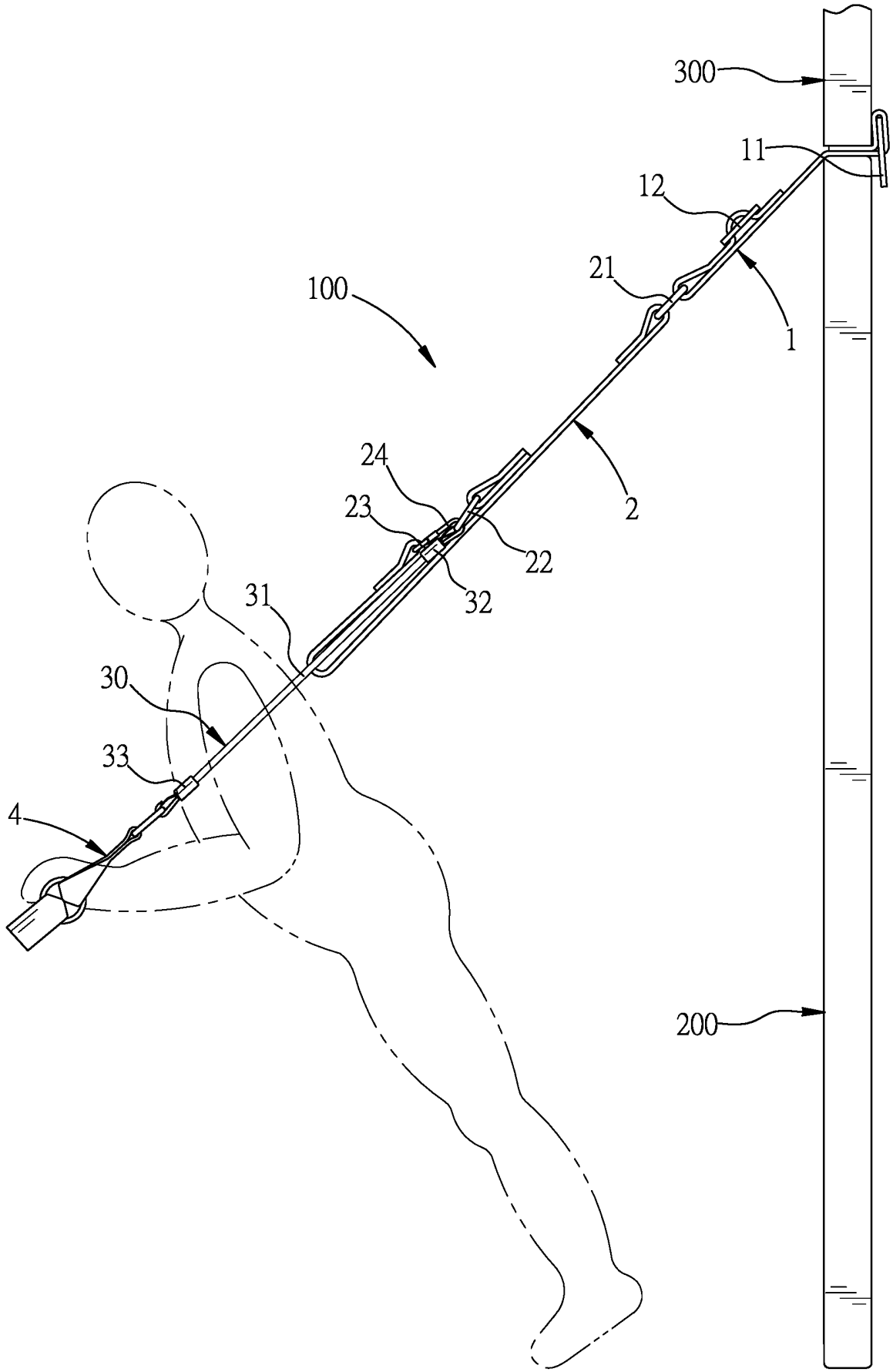

FIG. 10

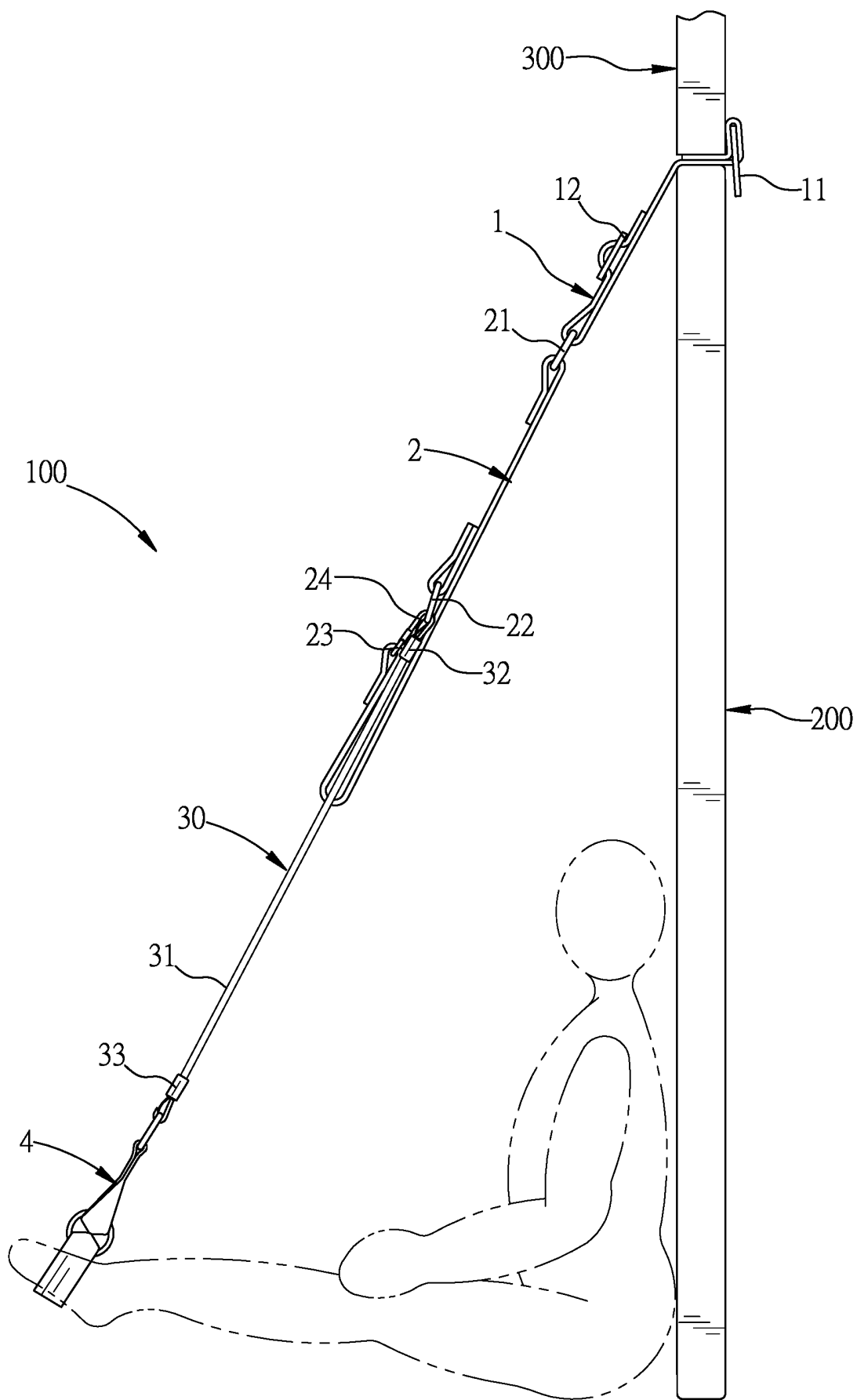

FIG. 11

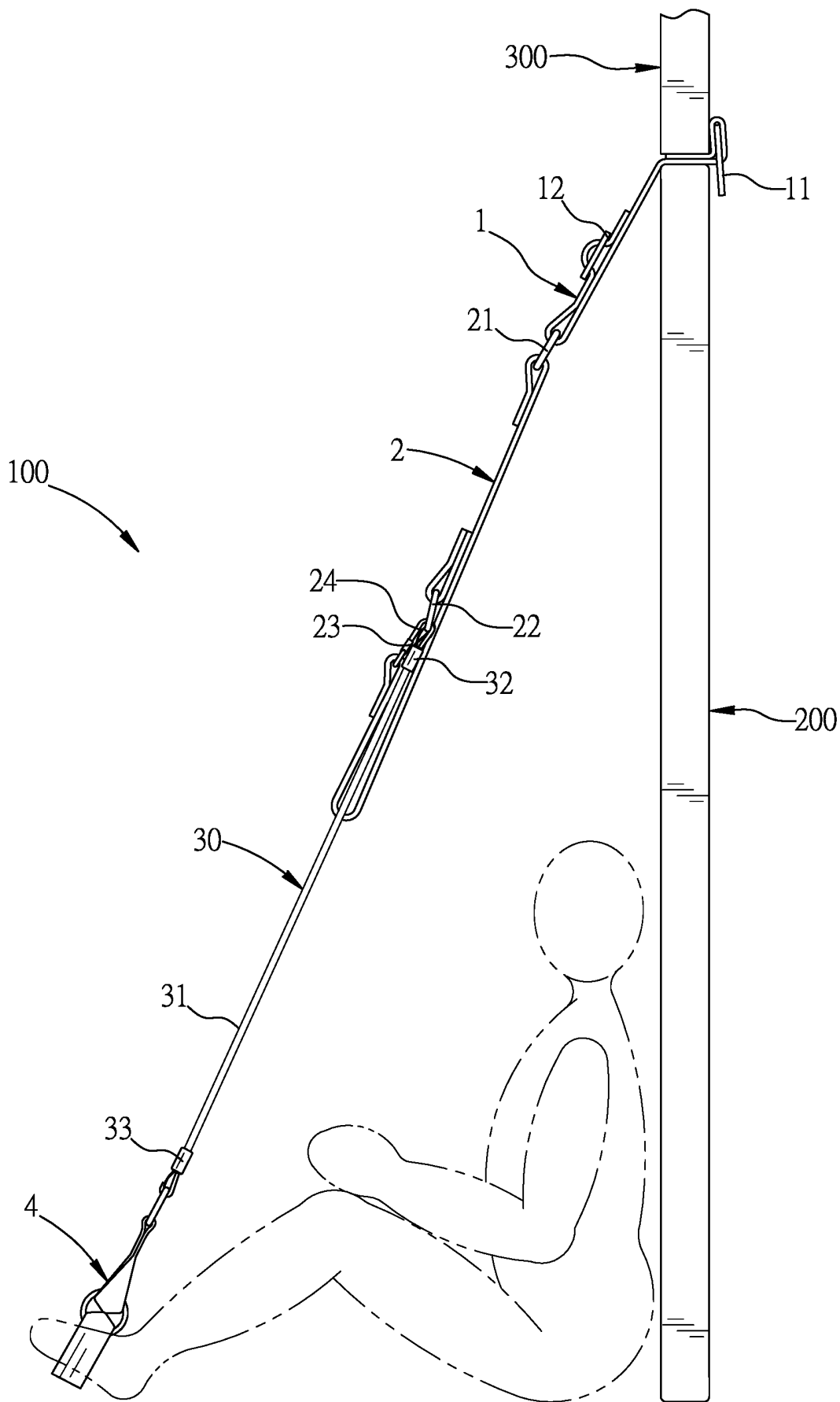

FIG. 12

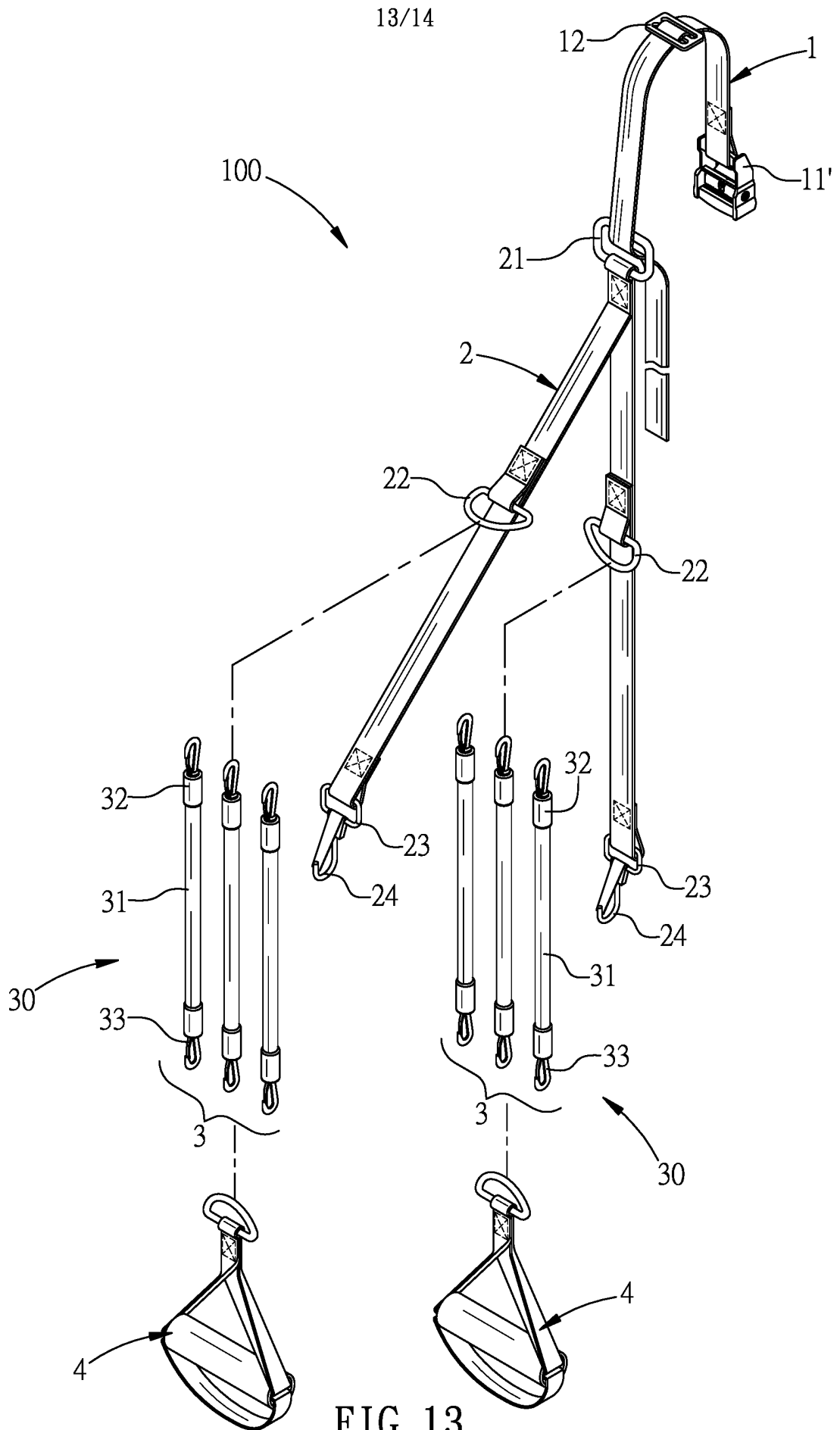

FIG. 13



