



US00D924030S

(12) **United States Design Patent** (10) **Patent No.:** **US D924,030 S**
Kaye, Jr. et al. (45) **Date of Patent:** **** Jul. 6, 2021**

- (54) **BLADE FOR OSCILLATING POWER TOOLS**
- (71) Applicant: **BLACK & DECKER INC.**, New Britain, CT (US)
- (72) Inventors: **Thomas R. Kaye, Jr.**, Fallston, MD (US); **Bradley J. Nohr**, Bel Air, MD (US)
- (73) Assignee: **Black & Decker Inc.**, New Britain, CT (US)
- (**) Term: **15 Years**
- (21) Appl. No.: **29/709,971**
- (22) Filed: **Oct. 18, 2019**

Related U.S. Application Data

- (63) Continuation of application No. 29/639,883, filed on Mar. 9, 2018, now Pat. No. Des. 871,185, which is a continuation of application No. 29/591,013, filed on Jan. 16, 2017, now Pat. No. Des. 814,900.

- (51) **LOC (13) Cl.** **08-05**
- (52) **U.S. Cl.** **D8/70; D8/20**
- USPC **D8/70; D8/20**

- (58) **Field of Classification Search**
- USPC D8/14, 16, 19, 20, 70, 98; D15/17, 129, D15/134, 138, 139
- CPC B23D 49/14; B23D 61/003; B23D 61/02; B23D 61/12; B23D 61/121; B23D 61/123; B23D 61/126; B23D 61/128; B25F 3/00; B25F 1/006; B25F 1/02; D26B 5/001

See application file for complete search history.

(56) **References Cited**

U.S. PATENT DOCUMENTS

- 2,305,465 A 12/1942 Bangser
- D137,633 S 4/1944 Jacobsen
- 2,682,184 A 6/1954 Szarkowski
- 2,693,365 A 11/1954 Zelewsky
- 2,766,791 A 10/1956 Givens

- 2,785,515 A 3/1957 Sansig
- 2,997,819 A 8/1961 Schact
- 3,055,497 A 9/1962 Klonski
- 3,433,082 A 3/1969 Bitter et al.
- 3,436,875 A 4/1969 Cheney
- 3,440,915 A 4/1969 Weyant
- 3,554,197 A 1/1971 Dobbie
- 3,656,393 A 4/1972 Goellner
- 3,706,474 A 12/1972 Neuenberg
- 3,905,374 A 9/1975 Winter
- 3,943,934 A 3/1976 Bent
- 4,015,371 A 4/1977 Grayston
- 4,059,930 A 11/1977 Alessio
- 4,106,181 A 8/1978 Mattchen
- 4,112,541 A 9/1978 Tetradis
- 4,252,121 A 2/1981 Arnegger
- 4,253,776 A 3/1981 Orain
- 4,265,285 A 5/1981 Fodor
- 4,386,609 A 6/1983 Mongeon
- 4,393,626 A 7/1983 Schroer
- 4,513,742 A 4/1985 Arnegger
- 4,590,837 A 5/1986 Nanba
- 4,597,227 A 7/1986 Gentischer et al.
- 4,599,077 A 7/1986 Vuillard
- 4,648,735 A 3/1987 Oddenino
- 4,700,478 A 10/1987 Mezger et al.
- 4,784,034 A 11/1988 Stones et al.
- 4,825,091 A 4/1989 Breyer et al.
- 4,891,884 A 1/1990 Torbet
- RE33,335 E 9/1990 Kaye et al.
- 4,980,976 A 1/1991 Junginger et al.
- 4,989,374 A 2/1991 Rudolf et al.
- 5,022,188 A 6/1991 Borst
- 5,027,684 A 7/1991 Neukam
- 5,038,478 A 8/1991 Mezger et al.
- 5,064,325 A 11/1991 McRoskey
- 5,085,589 A 2/1992 Kan
- 5,107,737 A 4/1992 Tagliaferri
- 5,122,142 A 6/1992 Pascaloff
- 5,157,873 A 10/1992 Rudolf et al.
- 5,199,223 A 4/1993 Rudolf et al.
- 5,219,378 A 6/1993 Arnold
- 5,235,719 A 8/1993 Wimberley
- 5,263,283 A 11/1993 Rudolf et al.
- 5,265,343 A 11/1993 Pascaloff
- 5,269,784 A 12/1993 Mast
- D343,247 S 1/1994 Walen
- 5,303,688 A 4/1994 Chiuminatta et al.
- 5,306,025 A 4/1994 Langhoff
- 5,306,285 A 4/1994 Miller et al.
- 5,309,805 A 5/1994 Mezger et al.
- 5,352,229 A 10/1994 Goble et al.
- 5,366,312 A 11/1994 Raines

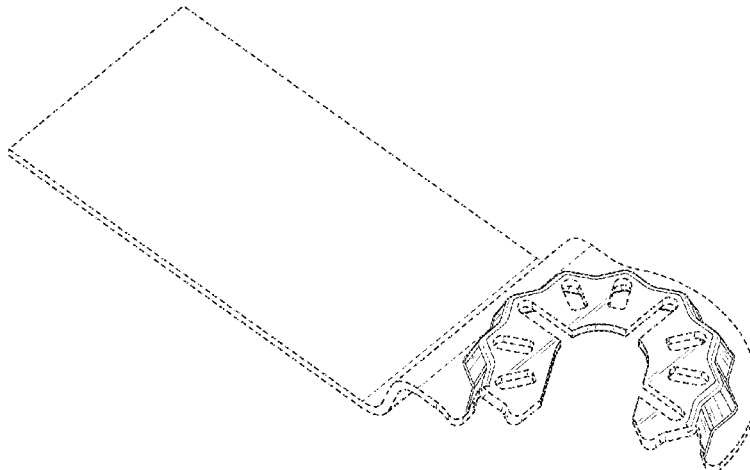

US D924,030 S

5,382,249	A	1/1995	Fletcher	7,189,239	B2	3/2007	Fisher et al.	
5,423,825	A	6/1995	Levine	7,207,873	B2	4/2007	Hesse et al.	
5,425,606	A	6/1995	Kelch	7,217,177	B2	5/2007	Frech et al.	
5,435,063	A	7/1995	Russo	D544,007	S	6/2007	Marasco	
D360,946	S	8/1995	Goris	7,225,714	B2	6/2007	Rompel et al.	
5,440,811	A	8/1995	Challis	7,237,988	B2	7/2007	Steadings et al.	
D362,065	S	9/1995	Goris	7,258,351	B2	8/2007	Hoffmann et al.	
5,468,176	A	11/1995	Udert et al.	7,258,515	B2	8/2007	Krondorfer	
5,468,247	A	11/1995	Matthai et al.	7,328,752	B2	2/2008	Gass et al.	
5,480,507	A	1/1996	Arnold	7,334,511	B2	2/2008	Hesselberg et al.	
5,489,285	A	2/1996	Goris	D563,186	S	3/2008	Ahn	
5,496,316	A	3/1996	Goris	7,344,435	B2	3/2008	Pollak et al.	
D368,777	S	4/1996	Goble et al.	7,447,565	B2	11/2008	Corwin	
5,507,763	A	4/1996	Petersen et al.	7,478,979	B2	1/2009	Zhou et al.	
D374,286	S	10/1996	Goble et al.	7,481,608	B2	1/2009	Zhou et al.	
D374,287	S	10/1996	Goble et al.	7,497,860	B2	3/2009	Carusillo et al.	
D374,482	S	10/1996	Goble et al.	7,527,628	B2	5/2009	Fletcher et al.	
5,658,304	A	8/1997	Lim	7,533,470	B2	5/2009	Nottingham et al.	
5,676,680	A	10/1997	Lim	7,537,065	B2	5/2009	Gallagher et al.	
5,694,693	A	12/1997	Hutchins et al.	7,540,334	B2	6/2009	Gass et al.	
5,702,415	A	12/1997	Matthai et al.	7,690,871	B2	4/2010	Steadings et al.	
5,729,904	A	3/1998	Trott	7,699,566	B2	4/2010	Nickels, Jr. et al.	
5,735,866	A	4/1998	Adams et al.	7,717,191	B2	5/2010	Trautner	
D394,315	S	5/1998	Fisher	7,717,192	B2	5/2010	Schroeder et al.	
5,785,571	A	7/1998	Camp	7,726,917	B2	6/2010	Mack	
5,829,931	A	11/1998	Doumani	7,735,575	B2	6/2010	Trautner	
5,839,196	A	11/1998	Trott	7,746,448	B2	6/2010	Frantza et al.	
5,848,473	A	12/1998	Brandenburg, Jr.	D619,152	S	7/2010	Evatt et al.	
D404,485	S	1/1999	Hutchins et al.	7,753,381	B2	7/2010	Nickels, Jr. et al.	
5,857,237	A	1/1999	Dranginis	7,762,349	B2	7/2010	Trautner et al.	
D405,177	S	2/1999	Hutchins et al.	7,784,166	B2	8/2010	Tanner	
D406,223	S	3/1999	Tran	D623,034	S	9/2010	Evatt et al.	
5,957,469	A	9/1999	Miles et al.	7,798,245	B2	9/2010	Trautner	
6,022,353	A	2/2000	Fletcher et al.	7,833,241	B2	11/2010	Gant	
6,073,939	A	6/2000	Steadings et al.	7,841,601	B2	11/2010	Mack	
6,082,515	A	7/2000	Oono et al.	7,854,274	B2	12/2010	Trautner et al.	
6,099,397	A	8/2000	Wurst	D633,769	S	3/2011	Evatt et al.	
6,116,996	A	9/2000	Yanase	D633,928	S	3/2011	Nilsson et al.	
6,132,282	A	10/2000	Camp	7,901,424	B2	3/2011	Fletcher et al.	
6,132,300	A	10/2000	Martin	7,950,152	B2	5/2011	Gallego	
6,179,301	B1	1/2001	Steadings et al.	7,976,253	B2	7/2011	Steadings et al.	
6,196,554	B1	3/2001	Gaddis et al.	7,987,920	B2	8/2011	Schroeder et al.	
6,241,259	B1	6/2001	Gaddis et al.	7,997,586	B2	8/2011	Ziegler et al.	
6,340,022	B1	1/2002	Schroer	D646,539	S	10/2011	Maras	
D459,805	S	7/2002	Pascaloff	D646,540	S	10/2011	Maras	
6,430,465	B2	8/2002	Cutler	D646,542	S	10/2011	Wackwitz	
6,434,835	B1	8/2002	Grunikiewicz et al.	8,038,156	B2	10/2011	Nickels, Jr. et al.	
6,435,521	B2	8/2002	Steadings et al.	D648,762	S	11/2011	Mack	
D462,766	S	9/2002	Jacobs et al.	8,047,100	B2	11/2011	King	
6,488,287	B2	12/2002	Gaddis et al.	D651,062	S *	12/2011	Wackwitz	D8/70
6,499,381	B2	12/2002	Ladish et al.	8,070,168	B2	12/2011	Mack	
6,503,253	B1	1/2003	Fletcher et al.	8,082,671	B2	12/2011	Saegesser	
6,536,536	B1	3/2003	Gass et al.	D651,499	S *	1/2012	Tong	D8/70
6,569,001	B2	5/2003	Rudolf et al.	D651,874	S	1/2012	Davidian et al.	
6,629,484	B2	10/2003	Soyama et al.	D651,875	S	1/2012	Davidian et al.	
6,678,062	B2	1/2004	Haugen et al.	D651,876	S	1/2012	Davidian et al.	
6,705,807	B1	3/2004	Rudolph et al.	D651,877	S	1/2012	Davidian et al.	
6,723,101	B2	4/2004	Fletcher et al.	D651,878	S	1/2012	Davidian et al.	
D489,823	S	5/2004	Fisher et al.	D652,274	S	1/2012	Davidian et al.	
6,747,745	B2	6/2004	Ishikawa et al.	D653,523	S	2/2012	Wackwitz et al.	
6,796,888	B2	9/2004	Jasch	8,109,343	B2	2/2012	Schroeder et al.	
6,802,764	B2	10/2004	Besch	8,113,520	B2	2/2012	Zaiser et al.	
6,832,764	B2	12/2004	Steadings et al.	8,151,679	B2	4/2012	Bohne	
6,834,730	B2	12/2004	Gass et al.	D665,242	S	8/2012	Wackwitz	
6,865,813	B2	3/2005	Pollak	D682,651	S	5/2013	McRoberts et al.	
6,869,346	B2	3/2005	Wendt et al.	D682,652	S *	5/2013	McRoberts	D8/70
6,945,862	B2	9/2005	Jasch et al.	D693,193	S	11/2013	Bozic	
6,949,110	B2	9/2005	Ark et al.	D694,077	S	11/2013	Bozic	
6,968,933	B2	11/2005	Buckhouse et al.	D694,596	S *	12/2013	Davidian	D8/20
7,001,403	B2	2/2006	Hausmann et al.	D694,597	S *	12/2013	Davidian	D8/20
7,015,445	B2	3/2006	Bishop	D694,598	S *	12/2013	Davidian	D8/20
7,077,735	B2	7/2006	Krondorfer et al.	D694,599	S *	12/2013	Davidian	D8/20
7,093,668	B2	8/2006	Gass et al.	D697,384	S	1/2014	Wackwitz	
7,107,691	B2	9/2006	Nottingham et al.	D697,776	S *	1/2014	Bozic	D8/70
7,115,027	B2	10/2006	Thomaschewski	D697,777	S *	1/2014	Bozic	D8/70
7,121,358	B2	10/2006	Gass et al.	D706,595	S *	6/2014	Kaye, Jr.	D8/20
7,128,503	B2	10/2006	Steadings et al.	8,915,499	B2	12/2014	Kaye et al.	
7,169,025	B2	1/2007	Schumacher	8,925,931	B2	1/2015	Sergyenko et al.	
7,175,625	B2	2/2007	Culbert	9,067,293	B2	6/2015	Bernardi et al.	

US D924,030 S

D734,649	S	7/2015	Wackwitz	2011/0227300	A1	9/2011	Zhang et al.
9,073,195	B2	7/2015	Kaye, Jr. et al.	2011/0266757	A1	11/2011	Steadings et al.
D741,125	S	10/2015	Peskorse et al.	2011/0266758	A1*	11/2011	Sergyeyenko B27B 5/32
D741,135	S *	10/2015	Yang				279/106
D741,136	S *	10/2015	Yang	2011/0266759	A1	11/2011	Goldman
9,186,770	B2*	11/2015	Montplaisir	2011/0277611	A1*	11/2011	Chen B23D 61/025
D746,655	S	1/2016	Wackwitz				83/699.51
9,242,361	B2	1/2016	Kaye, Jr. et al.	2011/0316241	A1	11/2011	Zhang et al.
D750,461	S *	3/2016	McRoberts	2011/0291368	A1	12/2011	Chen et al.
9,346,183	B2	5/2016	Fankhauser et al.	2011/0309589	A1	12/2011	Maras
9,486,887	B2	11/2016	Fankhauser et al.	2011/0315414	A1	12/2011	Kuntner et al.
9,486,909	B2	11/2016	Zieger et al.	2011/0316242	A1	12/2011	Zhang et al.
9,555,554	B2	1/2017	Thorson et al.	2012/0025476	A1	2/2012	Nickels, Jr. et al.
D789,759	S	6/2017	Fellmann et al.	2012/0031636	A1	2/2012	King
9,694,472	B2	7/2017	Luescher et al.	2012/0073410	A1	3/2012	Hoffman et al.
9,737,969	B2*	8/2017	Bek	2012/0090863	A1	4/2012	Puzio et al.
D809,356	S	2/2018	Butscher et al.	2012/0144971	A1	6/2012	Bohne
D814,900	S *	4/2018	Kaye, Jr.	2012/0169018	A1	7/2012	Lu et al.
D817,128	S	5/2018	Gopi	2012/0170976	A1*	7/2012	Cai B27B 5/32
D871,185	S *	12/2019	Kaye, Jr.				403/359.1
2001/0041524	A1	11/2001	Steiger et al.	2013/0104719	A1	5/2013	Rubens et al.
2002/0070037	A1	6/2002	Jasch	2013/0193655	A1*	8/2013	Kaye, Jr. B24B 45/006
2002/0104421	A1	8/2002	Wurst				279/141
2002/0116023	A1	8/2002	Fletcher et al.	2014/0035242	A1	2/2014	Kaye et al.
2002/0198556	A1	12/2002	Ark et al.	2014/0182873	A1	7/2014	Fankhauser et al.
2003/0014067	A1	1/2003	Kullmer et al.	2014/0190328	A1*	7/2014	Karlen B23D 65/00
2003/0032971	A1	2/2003	Hausmann et al.				83/853
2004/0098000	A1	5/2004	Kleinwaechter	2014/0252729	A1*	9/2014	Xu B25F 3/00
2004/0138668	A1	7/2004	Fisher et al.				279/143
2004/0204731	A1	10/2004	Gant	2014/0299345	A1	10/2014	McRoberts et al.
2004/0243136	A1	12/2004	Gupta et al.	2014/0325855	A1*	11/2014	Bozic B23D 61/006
2005/0178261	A1	8/2005	Thomaschewski				30/392
2005/0245935	A1	11/2005	Casey et al.	2015/0107096	A1*	4/2015	Luescher B24B 45/006
2006/0150428	A1	7/2006	Baculy				29/700
2006/0172669	A1	8/2006	Hesse et al.	2016/0184956	A1	6/2016	Klabunde et al.
2006/0217048	A1	9/2006	Frech et al.	2016/0199919	A1	7/2016	Klabunde et al.
2006/0272468	A1	12/2006	Gupta et al.	2016/0288288	A1	10/2016	Klabunde et al.
2006/0282108	A1	12/2006	Tanner				
2007/0060030	A1	3/2007	Pollak et al.				
2007/0093190	A1	4/2007	Schomisch				
2007/0229853	A1	10/2007	Cheng				
2007/0266837	A1	11/2007	Nickels et al.				
2007/0295156	A1	12/2007	Ziegler et al.				
2007/0295165	A1	12/2007	Tanaka et al.				
2008/0027449	A1	1/2008	Gundlapalli et al.				
2008/0190259	A1	8/2008	Bohne				
2008/0196911	A1	8/2008	Krapf et al.				
2009/0013540	A1	1/2009	Bohne				
2009/0023371	A1	1/2009	Blickle et al.				
2009/0051094	A1	2/2009	Sandmeier				
2009/0093815	A1	4/2009	Fletcher et al.				
2009/0138017	A1	5/2009	Carusillo et al.				
2009/0197514	A1	8/2009	Peisert				
2009/0198465	A1	8/2009	Decker et al.				
2009/0277022	A1	11/2009	Limberg et al.				
2009/0312761	A1	12/2009	Boykin et al.				
2009/0312762	A1	12/2009	Boykin				
2009/0312779	A1	12/2009	Boykin et al.				
2009/0318065	A1	12/2009	Zaiser et al.				
2009/0320625	A1	12/2009	Kildevaeld				
2009/0321625	A1	12/2009	Sieradzki et al.				
2010/0003906	A1	1/2010	Zaiser et al.				
2010/0009613	A1	1/2010	Frueh				
2010/0052269	A1	3/2010	Zaiser et al.				
2010/0056029	A1*	3/2010	Grunikiewicz				B24B 23/04
							451/442
2010/0193207	A1	8/2010	Mok et al.				
2010/0197208	A1	8/2010	Blickle et al.				
2010/0288099	A1	11/2010	Steiger				
2010/0300714	A1	12/2010	Trautner				
2011/0000690	A1	1/2011	Kildevaeld				
2011/0011605	A1	1/2011	Kildevaeld				
2011/0067894	A1	3/2011	Bernardi				
2011/0072946	A1	3/2011	Bernardi et al.				
2011/0086582	A1	4/2011	Takemura et al.				
2011/0097978	A1	4/2011	Hofmann et al.				
2011/0127731	A1	6/2011	Woecht et al.				
2011/0139472	A1	6/2011	Bohne				
2011/0147023	A1	6/2011	Herr				

FOREIGN PATENT DOCUMENTS

AU	2006305634	4/2007
CH	657411 A5	8/1986
CN	201728642	2/2011
CN	201824333 U1	5/2011
DE	1878647 U	8/1963
DE	2915292 A1	10/1980
DE	2935731 A1	4/1981
DE	3203670 A1	8/1983
DE	3520417 A1	12/1985
DE	3833735 A1	4/1989
DE	8618695 U1	9/1989
DE	4036904 C1	5/1992
DE	4209146 A1	9/1992
DE	29605728 U1	9/1996
DE	29607061 U1	10/1996
DE	29810157 U1	8/1998
DE	19736933 C1	10/1998
DE	29907671 U1	8/1999
DE	29809788 U1	9/1999
DE	19825408 A1	12/1999
DE	20303018 U1	4/2003
DE	10231393	1/2004
DE	10307840 B3	6/2004
DE	10325392 A1	12/2004
DE	102004020982 A1	11/2005
DE	202006001643 U1	3/2006
DE	102004050799 A1	4/2006
DE	102007018465 A1	10/2008
DE	102007018467 A1	10/2008
DE	202009004549 U1	6/2009
DE	202008001759 U1	7/2009
DE	102008001234 A1	10/2009
DE	202009013147 U1	1/2010
DE	202008011959 U1	2/2010
DE	102009030854 A1	1/2011
DE	202011050164 U1	10/2011
DE	202011050511 U1	11/2011
DE	202011051408 U1	2/2012

DE	102011005818	A1	9/2012
DE	102011085561	A1	12/2012
DE	102012201624	A1	8/2013
EP	0443362	A2	8/1991
EP	0554929	A1	8/1993
EP	0695607	A1	2/1996
EP	0776634	A2	6/1997
EP	0962283	A1	12/1999
EP	1694477	A1	6/2005
EP	1687120	A1	8/2006
EP	1819490	A1	8/2007
EP	1852218	A1	11/2007
EP	1882538	A2	1/2008
EP	2085182	A1	8/2009
EP	2143531	A1	1/2010
EP	2152475	A1	2/2010
EP	2159000	A1	3/2010
EP	2382929	A1	11/2011
JP	1158205	A	6/1989
JP	2006263914	A	10/2006
WO	WO-9424945	A1	11/1994
WO	WO-03097299	A1	11/2003
WO	WO-2004043269	A1	5/2004
WO	WO-2005056256	A1	6/2005
WO	WO-2006017066	A2	2/2006
WO	WO-2008151866	A1	12/2008
WO	WO-2009151958	A2	12/2009
WO	WO-2009151959	A1	12/2009
WO	WO-2009151965	A1	12/2009
WO	WO-2010020458	A1	2/2010
WO	WO-2013067960	A1	5/2013
WO	WO-2013012126		7/2013

OTHER PUBLICATIONS

Zimmer Inc., Brochure “Air Drive Blades—The Next Generation” dated Jun. 28, 1993, 1 page; © 1993 Zimmer, Inc.

Zimmer, Inc., Brochure “More Versatile ‘Graft’ Blades Available” dated Feb. 15, 1993, 2 pages; © 1993 Zimmer, Inc.

Materials from Stryker Corporation Brochure published prior to Jan. 1, 1994.

Aloe Medical Instruments “Gall Ball Retractor” Item B-1323, p. 115 © 1965.

Stryker Maintenance Manual entitled “System II OrthoPower 90 Battery Powered Surgical Instruments”—For Use With: 298-92, 94,96, 98 (Stryker Surgical Brochure 298-92-16 Rev (Mar. 1986). Sketch A related to p. 9 of the Stryker Maintenance Manual entitled “System II OrthoPower 90 Battery Powered Surgical Instruments” (Mar. 1986).

Pages 2, 3 and 5 of Stryker prior art brochure/-catalog No. 1420 Standard Bone Saw Handpiece, 1100 Series saw blades, and No. 1470 Sagittal Plane bone saw with Series 1370 blades.

Hall Surgical brochure—New Opposed-Tooth Blades—published prior to Jan. 1, 1994.

Dremel 6300-05 120-volt Multi-Max Oscillating Kit (retrieved on Sep. 30, 2014) viewed on the internet. <https://web.archive.org/web/20091224220316/http://www.amazon.com/Dremel-6300-05-120-Volt-Multi-Max-Oscillating/dp/B002WTCDXO> published on Dec. 24, 2009 as per Wayback Machine.

Dewaele, Karl—European Search Report—dated Jun. 20, 2014—7 pages—The Hague.

O’Connell, Wayne—Patent Examination Report No. 3 re Australian Patent Application No. 2011201633—dated Oct. 2, 2014—6 pages—Woden ACT, Canberra, Australia.

Dewaele, Karl—Examination Report re: European Patent Appln. No. 15160839.5-1701—dated Nov. 9, 2016—6 pages.

Kornmeier, Martin—Extended European Search Report re European Patent Appln. No. 13163355.4—dated Nov. 27, 2017—5 pages—Munich.

Dewaele, Karl—European Search Report re European Patent Appln. No. 18181208.2-1019—dated Oct. 16, 2018—9 pages—Munich.

Kornmeier, Martin—Search Report re European Patent Appln. No. 18200787.2-1016—dated Feb. 14, 2019—4 pages—Munich.

Kornmeier, Martin—Search Report re European Patent Appln. No. 18200791.4-1016—dated Feb. 14, 2019—4 pages—Munich.

Kornmeier, Martin—Search Report re European Patent Appln. No. 18200668.4-1016—dated Feb. 14, 2019—4 pages—Munich.

Kornmeier, Martin—Communication Pursuant to Article 94(3) EPC re European Patent Appln. No. 18200787.2-1016—dated Mar. 13, 2019—6 pages—Munich.

Kornmeier, Martin—Communication Pursuant to Article 94(3) EPC re European Patent Appln. No. 18200791.4-1016—dated Mar. 13, 2019—6 pages—Munich.

Kornmeier, Martin—Communication Pursuant to Article 94(3) EPC re European Patent Appln. No. 18200668.4-1016—dated Mar. 13, 2019—6 pages—Munich.

Gates, Andrew Eric—Extended European Search Report re European Patent Appln No. 18181208.2-1019—dated Oct. 16, 2018—9 pages—Munich.

Bosch & Fein, Communication of a notice of Opposition against EP 3 348 367 (17191446.8), Accessories for Oscillating Power Tools, Black & Decker Inc., EPO Munich, dated Jan. 11, 2021.

Translation of: Bosch & Fein, Communication of a notice of Opposition against EP 3 348 367 (17191446.8), Accessories for Oscillating Power Tools, Black & Decker Inc., EPO Munich, dated Jan. 11, 2021.

Bosch & Fein, Communication of a notice of Opposition against EP 3 456 473 (18200787.2), Oscillating Tool Adapter, Black & Decker Inc., EPO Munich, dated Feb. 18, 2021.

Translation of: Bosch & Fein, Communication of a notice of Opposition against EP 3 456 473 (18200787.2), Oscillating Tool Adapter, Black & Decker Inc., EPO Munich, dated Feb. 18, 2021.

Bosch & Fein, Communication of a notice of opposition against EP 3 418 004 (18181208.2), Universal Accessories for Oscillating Tools, Black & Decker Inc., EPO Munich, dated Mar. 5, 2021.

Translation of Bosch & Fein, Communication of a notice of opposition against EP 3 418 004 (18181208.2), Accessories for Oscillating Tools, Black & Decker Inc., EPO Munich, dated Mar. 5, 2021.

* cited by examiner

Primary Examiner — Darlington Ly

(74) *Attorney, Agent, or Firm* — Scott B. Markow

(57)

CLAIM

The ornamental design for a blade for oscillating power tools, as shown and described.

DESCRIPTION

FIG. 1 is a top perspective view of a blade for oscillating power tools in accordance with a first embodiment.

FIG. 2 is a right side elevation view thereof;

FIG. 3 is a left side elevation view thereof;

FIG. 4 is a rear elevation view thereof;

FIG. 5 is a front elevation view thereof;

FIG. 6 is a top plan view thereof;

FIG. 7 is a bottom plan view thereof; and

FIG. 8 is a bottom perspective view thereof.

FIG. 9 is a top perspective view of a blade for oscillating power tools in accordance with a second embodiment.

FIG. 10 is a right side elevation view thereof;

FIG. 11 is a left side elevation view thereof;

FIG. 12 is a rear elevation view thereof;

FIG. 13 is a front elevation view thereof;

FIG. 14 is a top plan view thereof;

FIG. 15 is a bottom plan view thereof; and

FIG. 16 is a bottom perspective view thereof.

FIG. 17 is a top perspective view of a blade for oscillating power tools in accordance with a third embodiment.

FIG. 18 is a right side elevation view thereof;

FIG. 19 is a left side elevation view thereof;

FIG. 20 is a rear elevation view thereof;

FIG. 21 is a front elevation view thereof;
FIG. 22 is a top plan view thereof;
FIG. 23 is a bottom plan view thereof; and
FIG. 24 is a bottom perspective view thereof.
FIG. 25 is a top perspective view of a blade for oscillating power tools in accordance with a fourth embodiment.
FIG. 26 is a right side elevation view thereof;
FIG. 27 is a left side elevation view thereof;
FIG. 28 is a rear elevation view thereof;
FIG. 29 is a front elevation view thereof;
FIG. 30 is a top plan view thereof;
FIG. 31 is a bottom plan view thereof; and
FIG. 32 is a bottom perspective view thereof.
FIG. 33 is a top perspective view of a blade for oscillating power tools in accordance with a fifth embodiment.
FIG. 34 is a right side elevation view thereof;
FIG. 35 is a left side elevation view thereof;
FIG. 36 is a rear elevation view thereof;
FIG. 37 is a front elevation view thereof;
FIG. 38 is a top plan view thereof;
FIG. 39 is a bottom plan view thereof; and
FIG. 40 is a bottom perspective view thereof.
FIG. 41 is a top perspective view of a blade for oscillating power tools in accordance with a sixth embodiment.
FIG. 42 is a right side elevation view thereof;
FIG. 43 is a left side elevation view thereof;
FIG. 44 is a rear elevation view thereof;

FIG. 45 is a front elevation view thereof;
FIG. 46 is a top plan view thereof;
FIG. 47 is a bottom plan view thereof; and
FIG. 48 is a bottom perspective view thereof.
FIG. 49 is a top perspective view of a blade for oscillating power tools in accordance with a seventh embodiment.
FIG. 50 is a right side elevation view thereof;
FIG. 51 is a left side elevation view thereof;
FIG. 52 is a rear elevation view thereof;
FIG. 53 is a front elevation view thereof;
FIG. 54 is a top plan view thereof;
FIG. 55 is a bottom plan view thereof; and
FIG. 56 is a bottom perspective view thereof.
FIG. 57 is a top perspective view of a blade for oscillating power tools in accordance with an eighth embodiment.
FIG. 58 is a right side elevation view thereof;
FIG. 59 is a left side elevation view thereof;
FIG. 60 is a rear elevation view thereof;
FIG. 61 is a front elevation view thereof;
FIG. 62 is a top plan view thereof;
FIG. 63 is a bottom plan view thereof; and,
FIG. 64 is a bottom perspective view thereof.
The broken lines in the drawings illustrate portions of the blade for oscillating power tools that form no part of the claimed design.

1 Claim, 48 Drawing Sheets

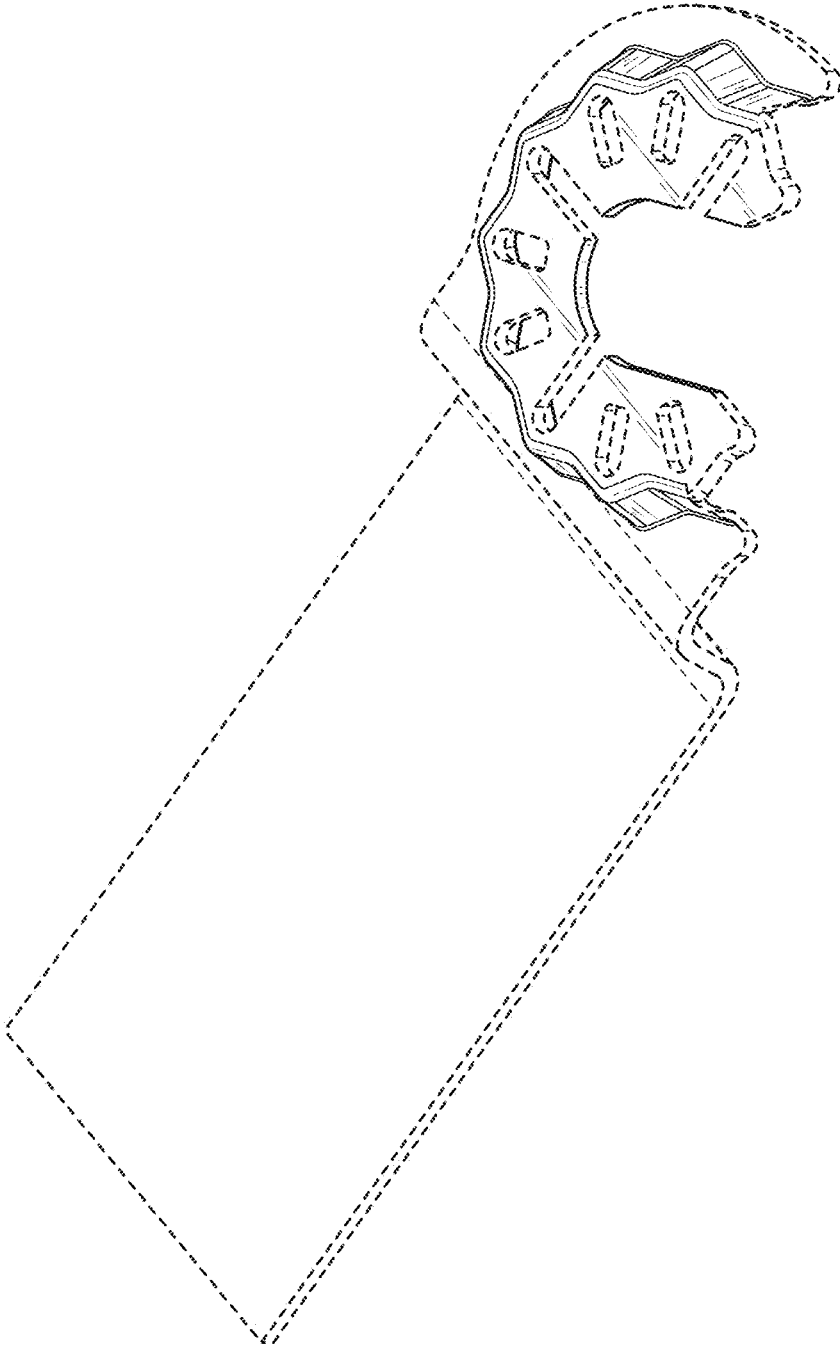

FIG. 1

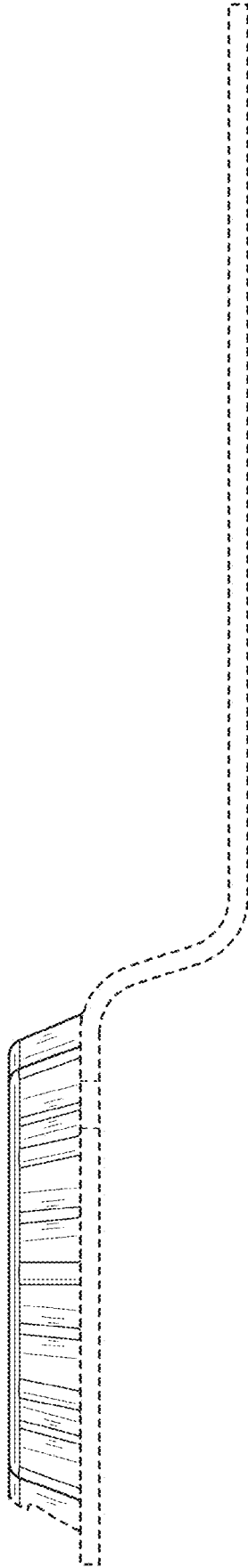

FIG. 2

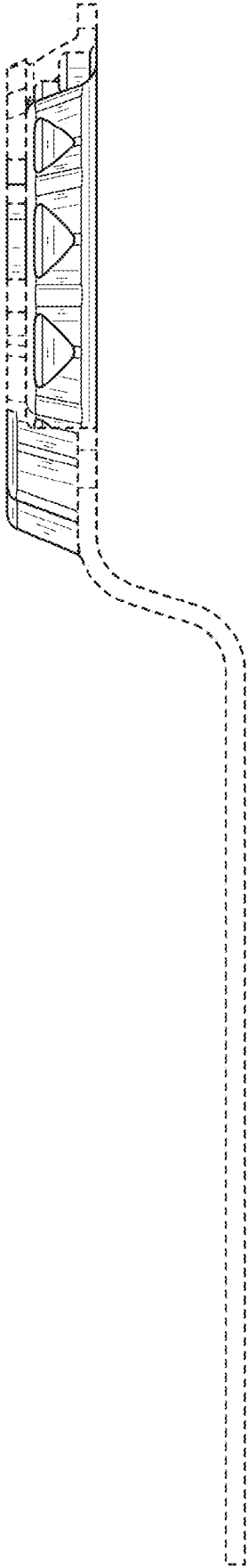

FIG. 3

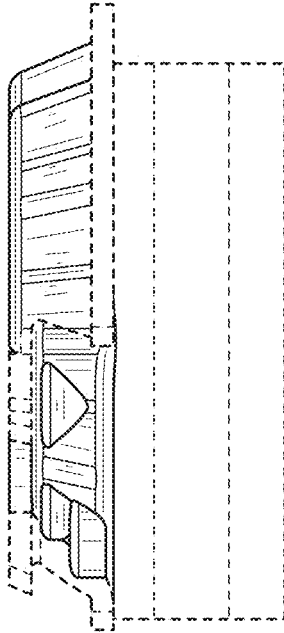

FIG. 4

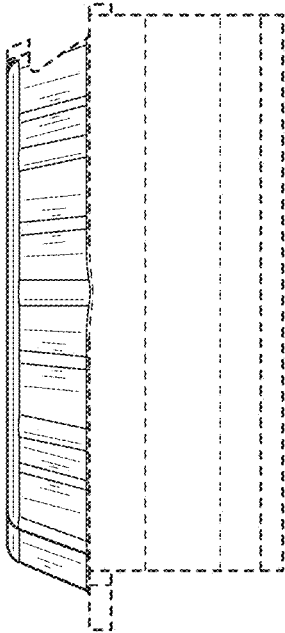

FIG. 5

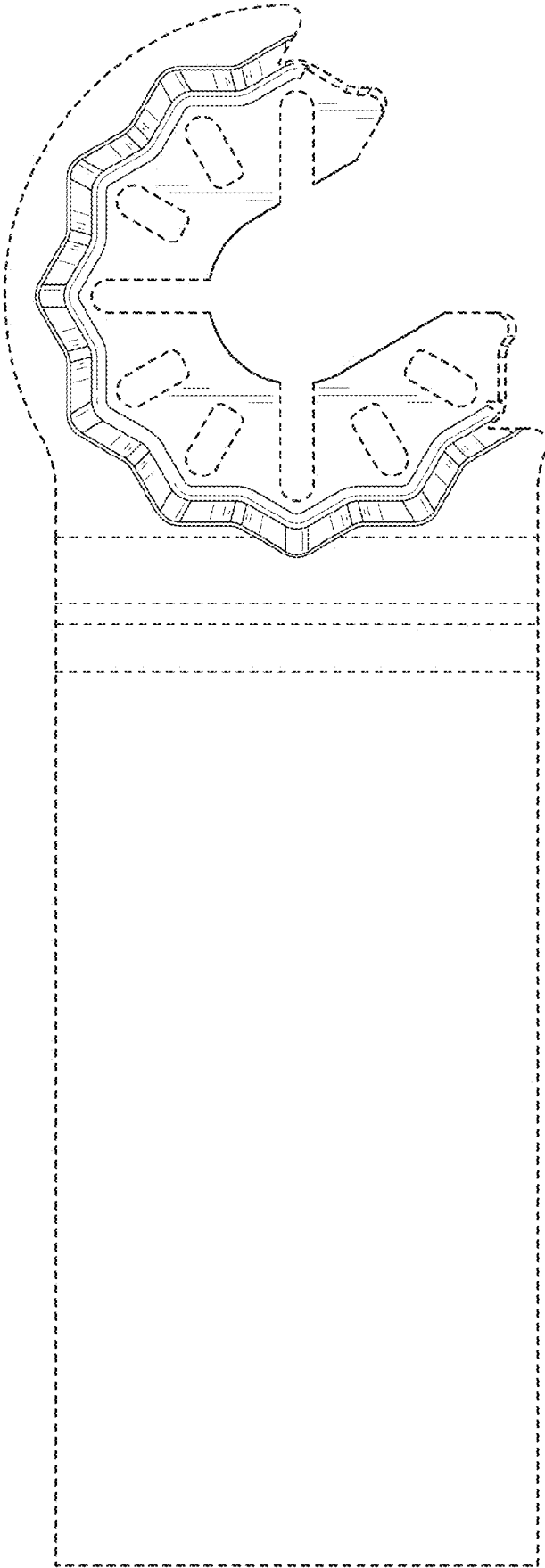

FIG. 6

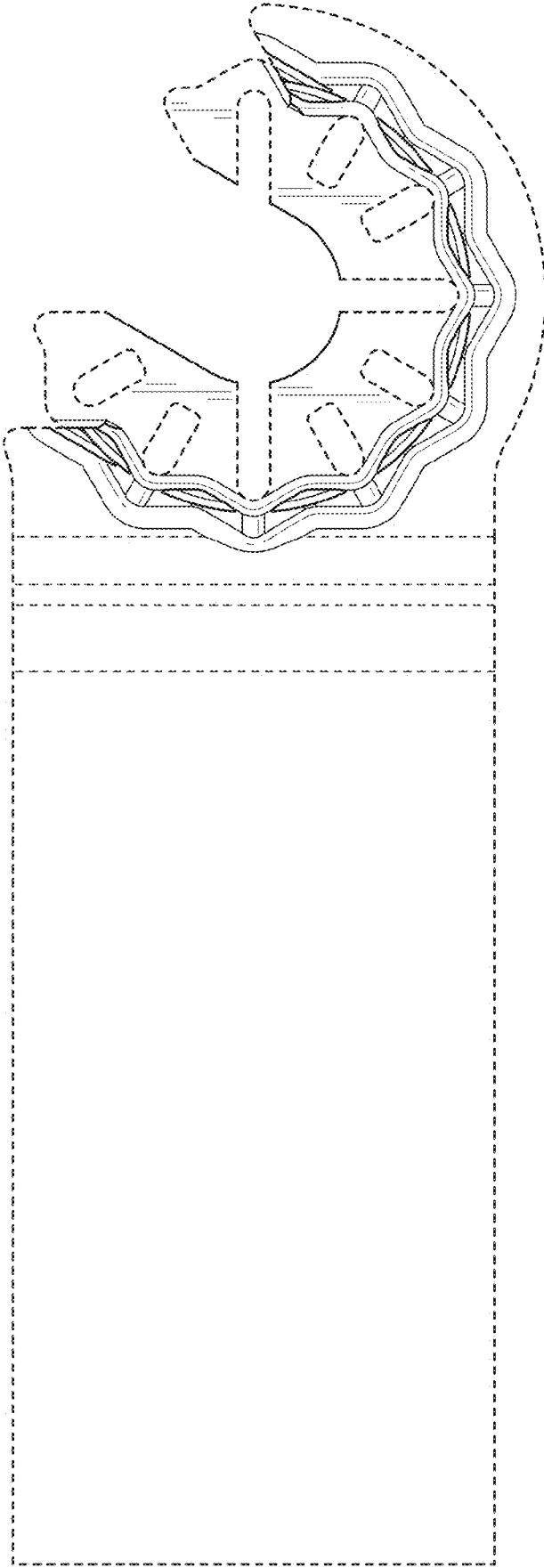

FIG. 7

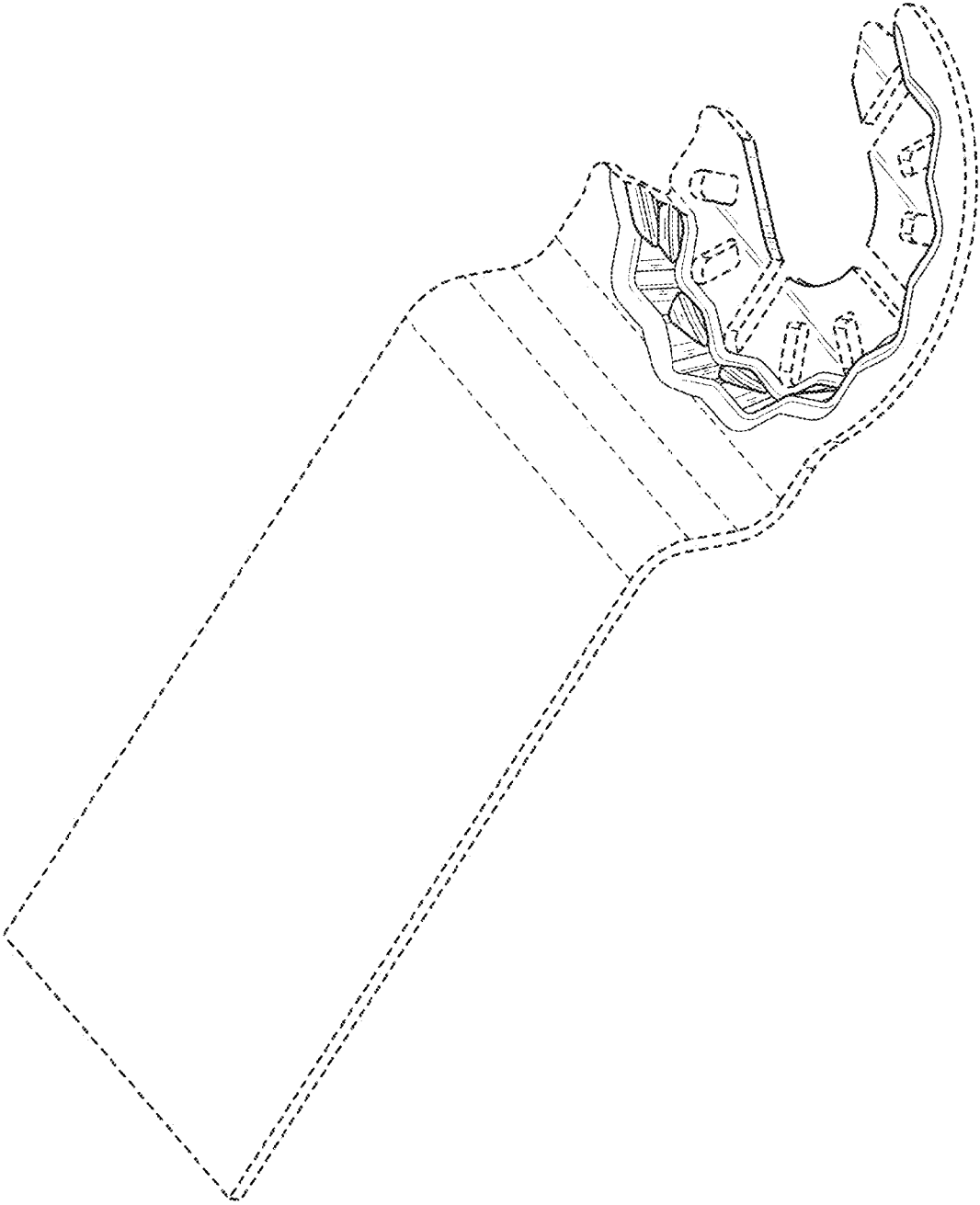

FIG. 8

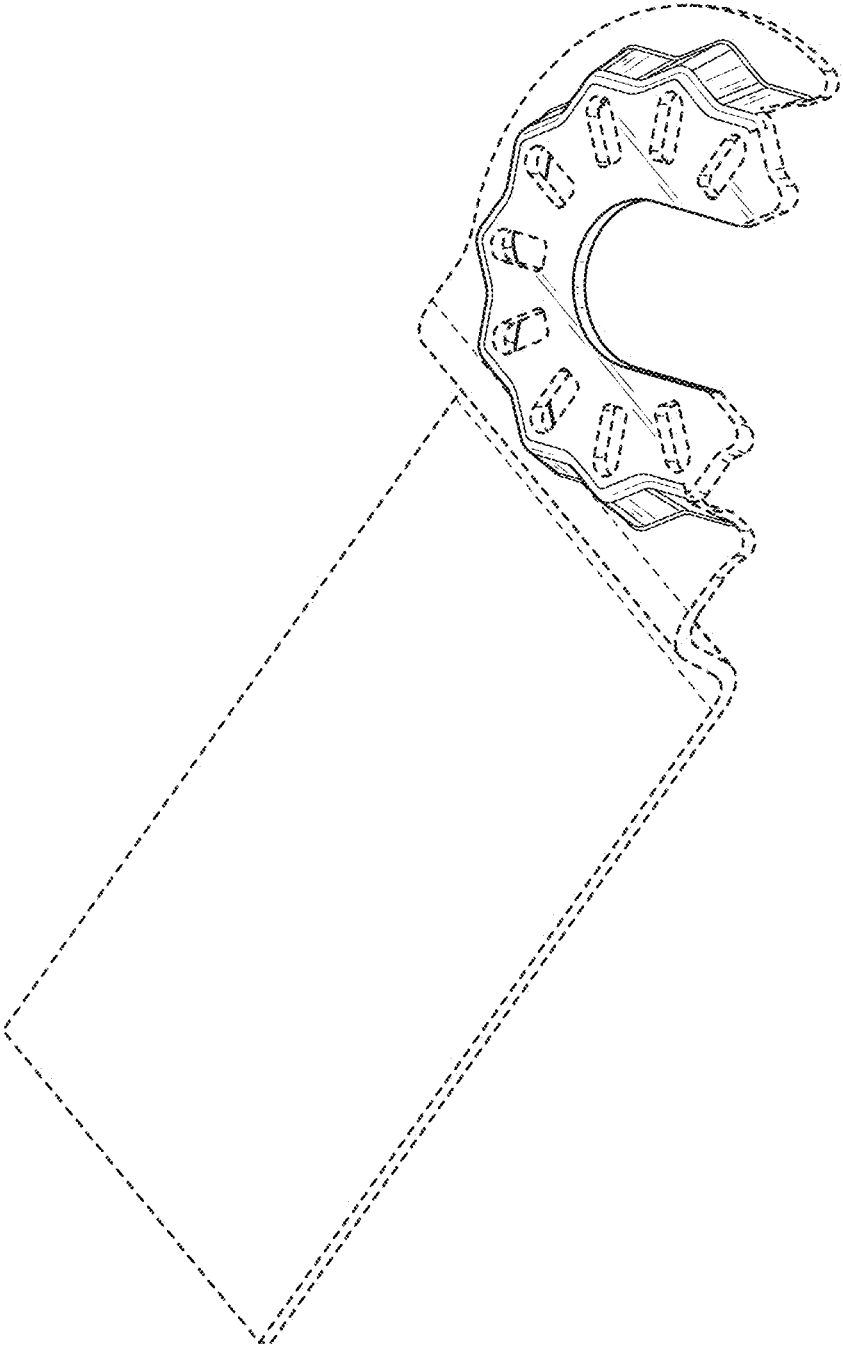

FIG. 9

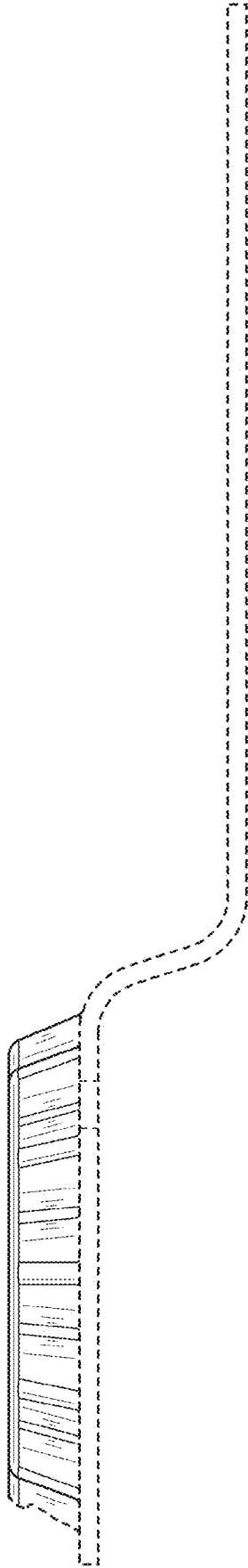

FIG. 10

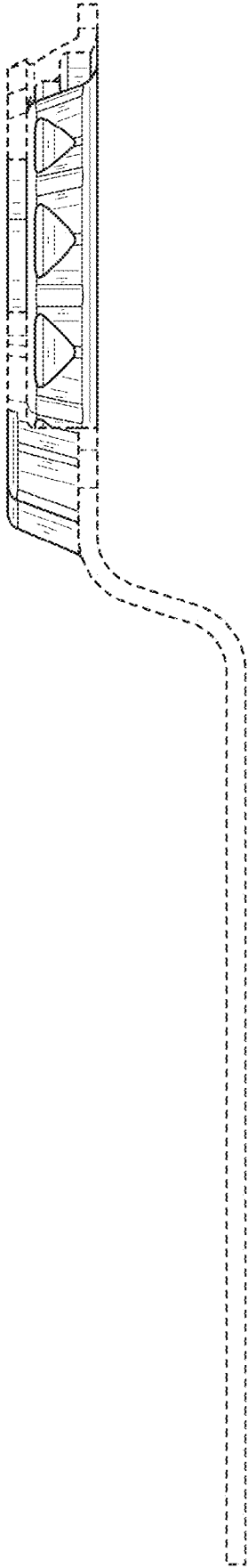

FIG. 11

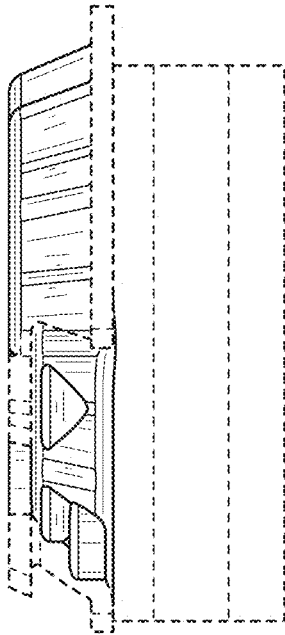

FIG. 12

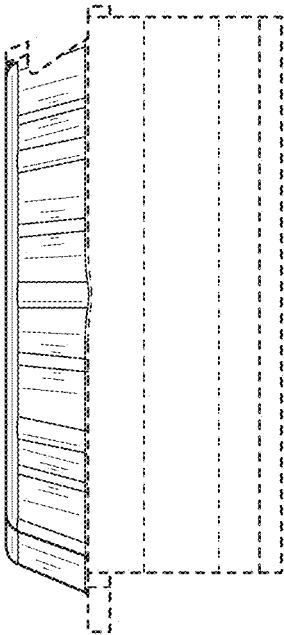

FIG. 13

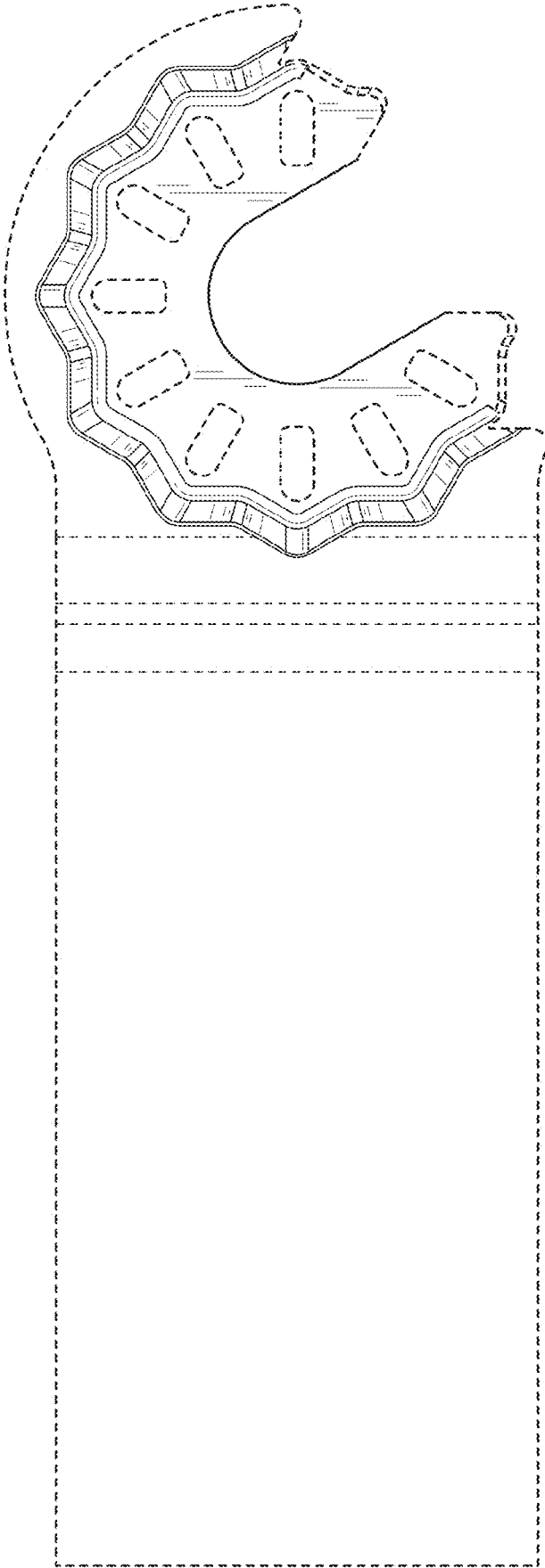

FIG. 14

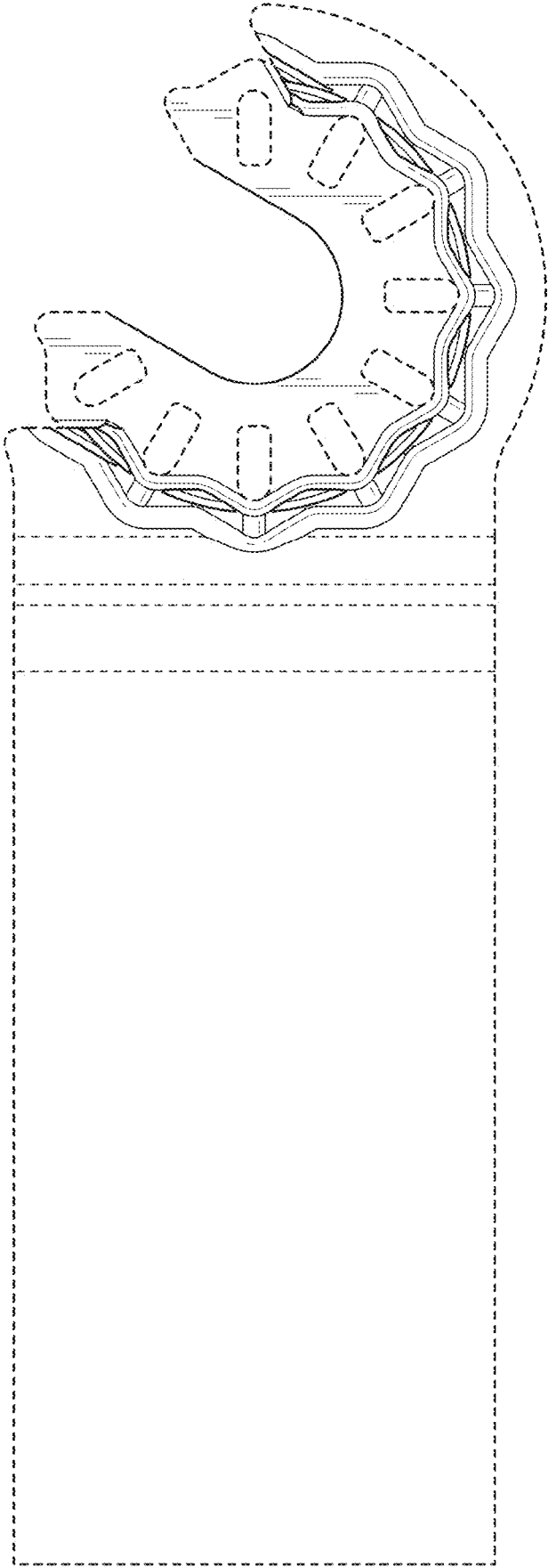

FIG. 15

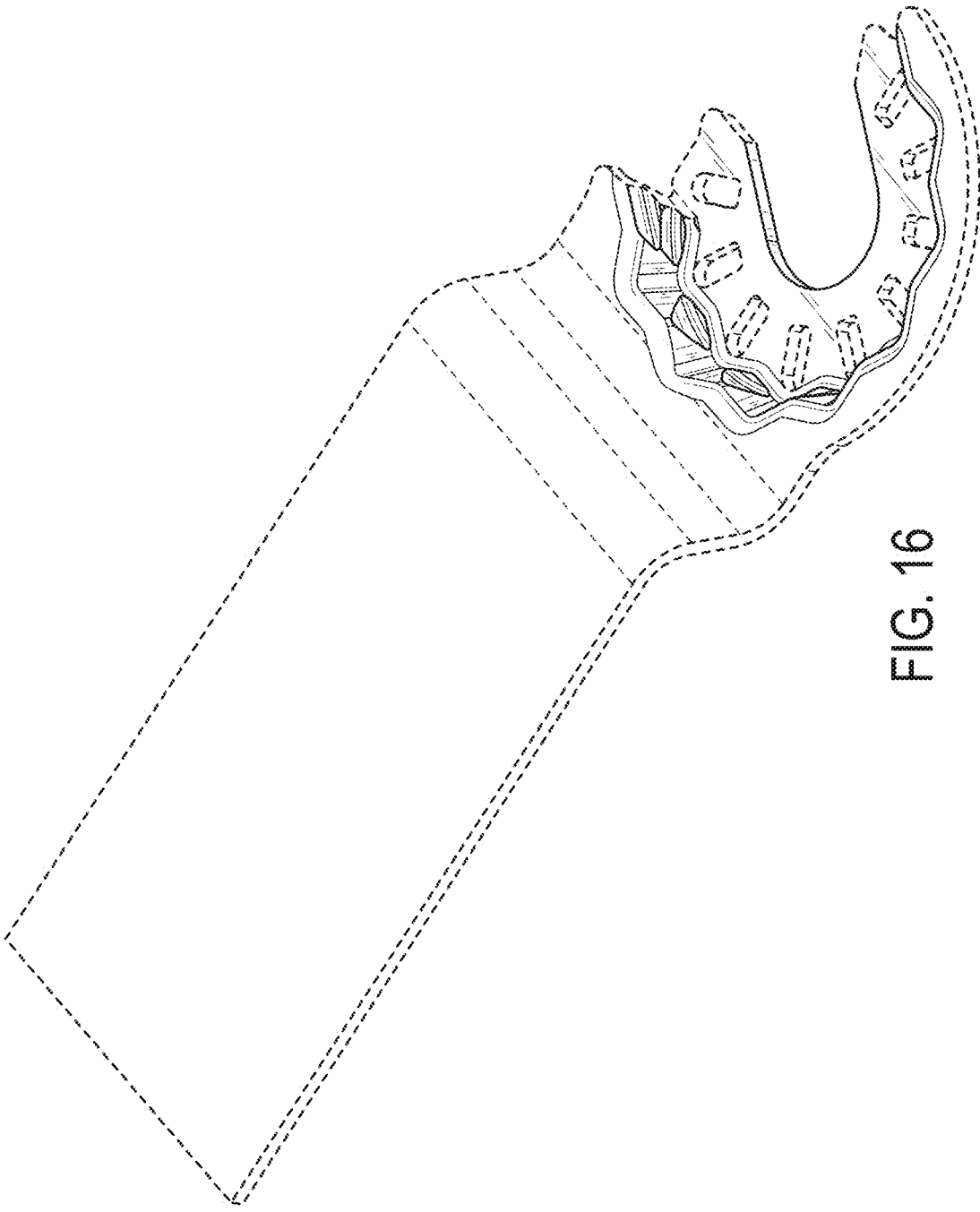

FIG. 16

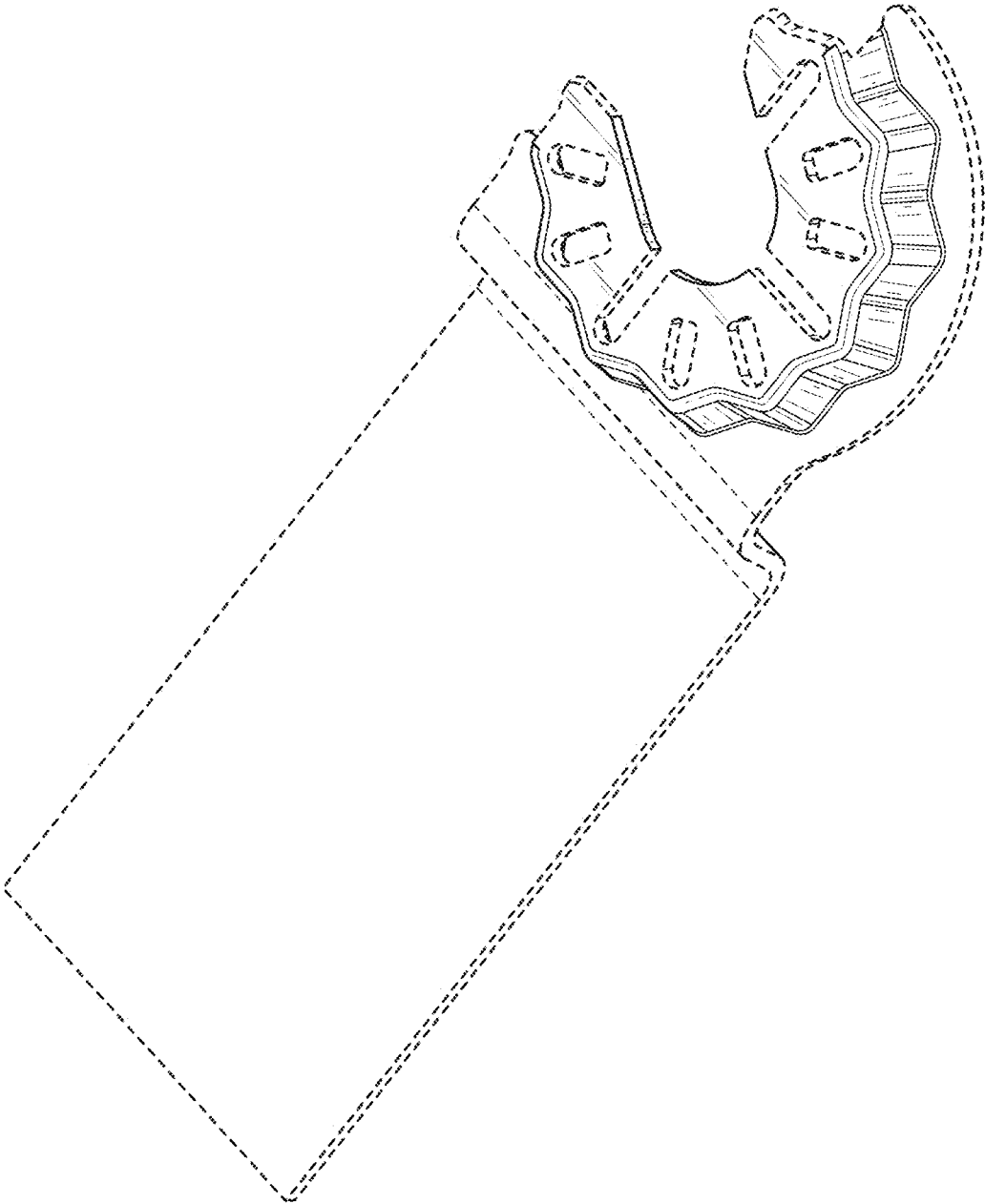

FIG. 17

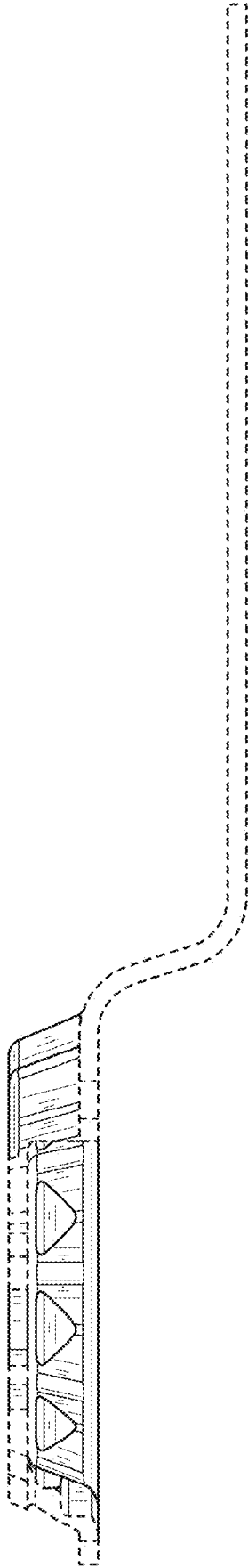

FIG. 18

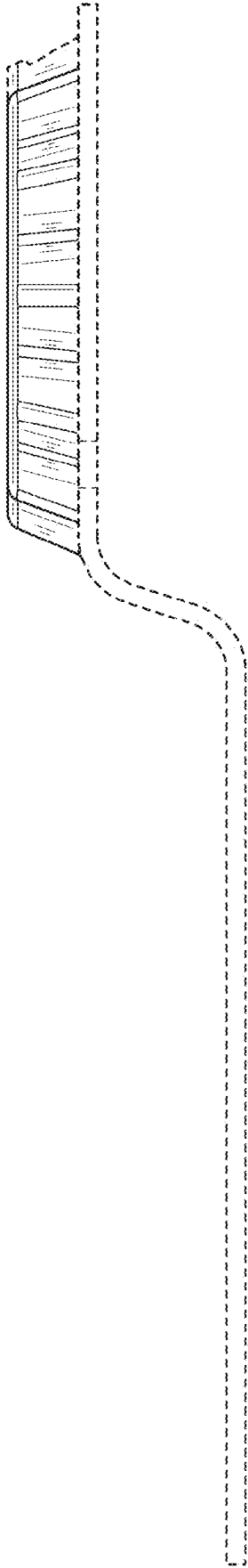

FIG. 19

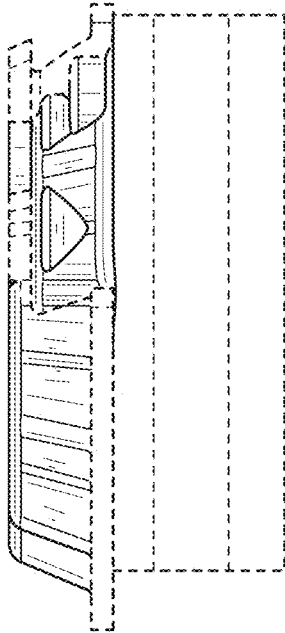

FIG. 20

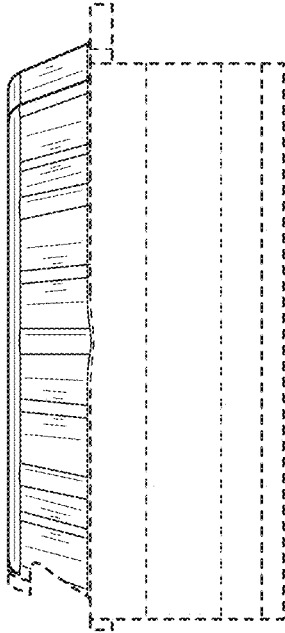

FIG. 21

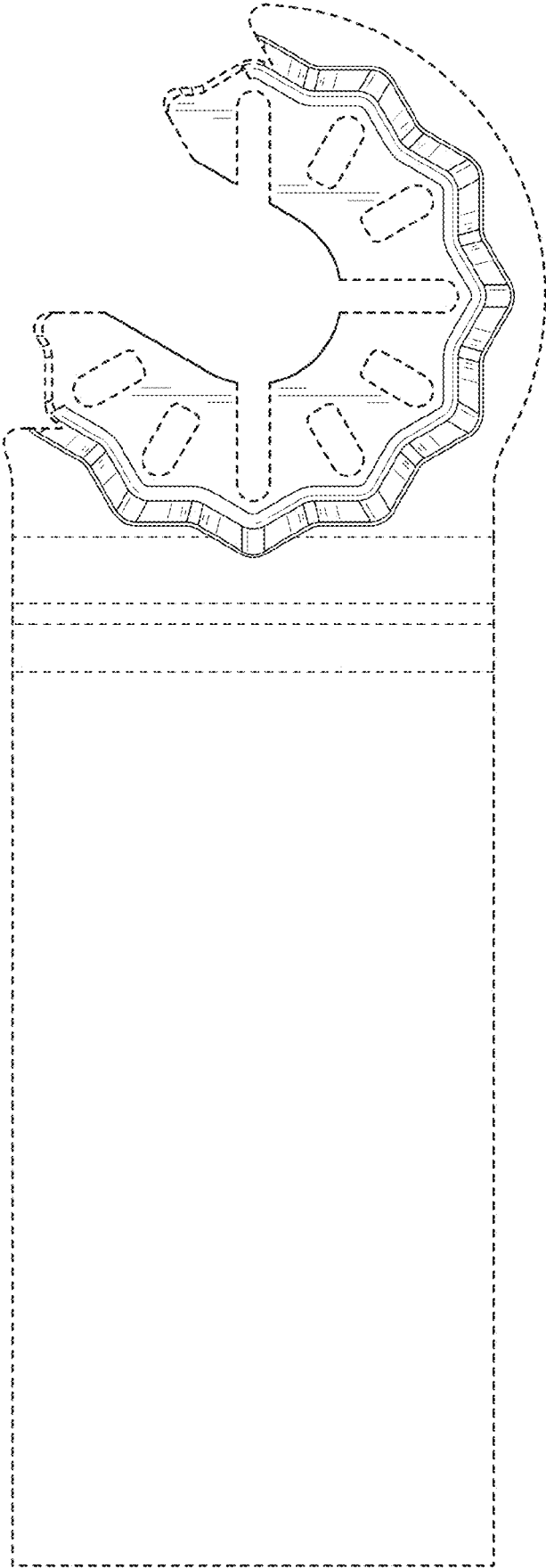

FIG. 22

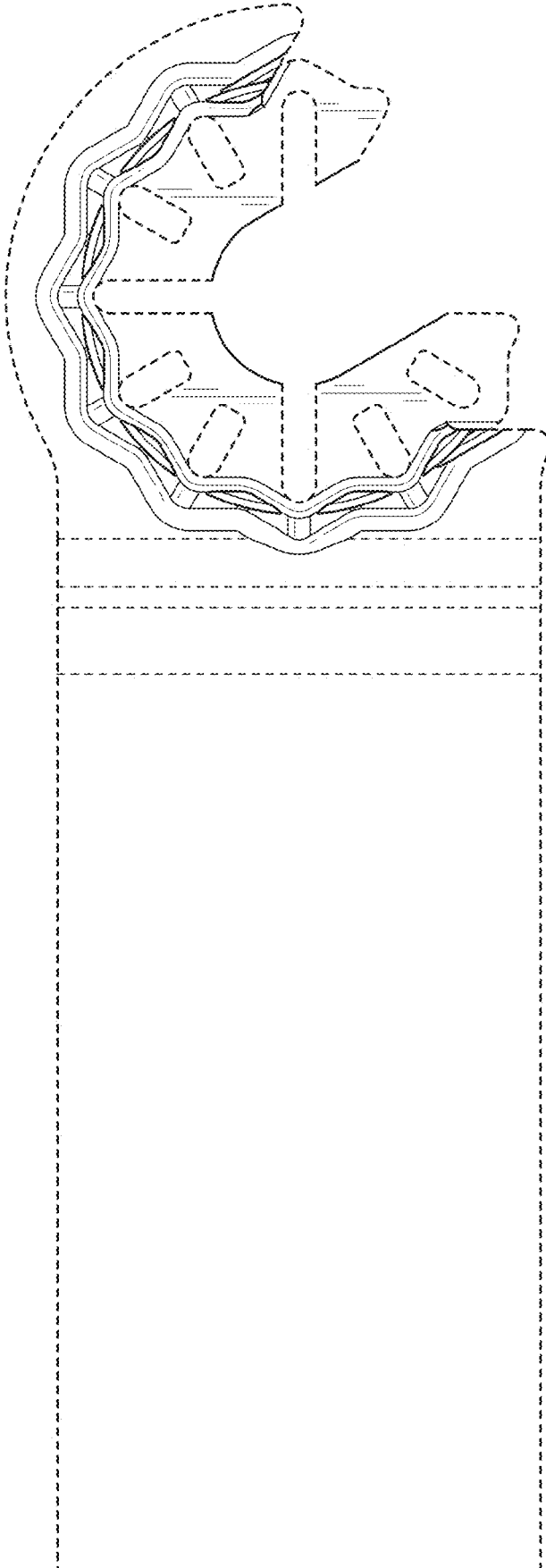

FIG. 23

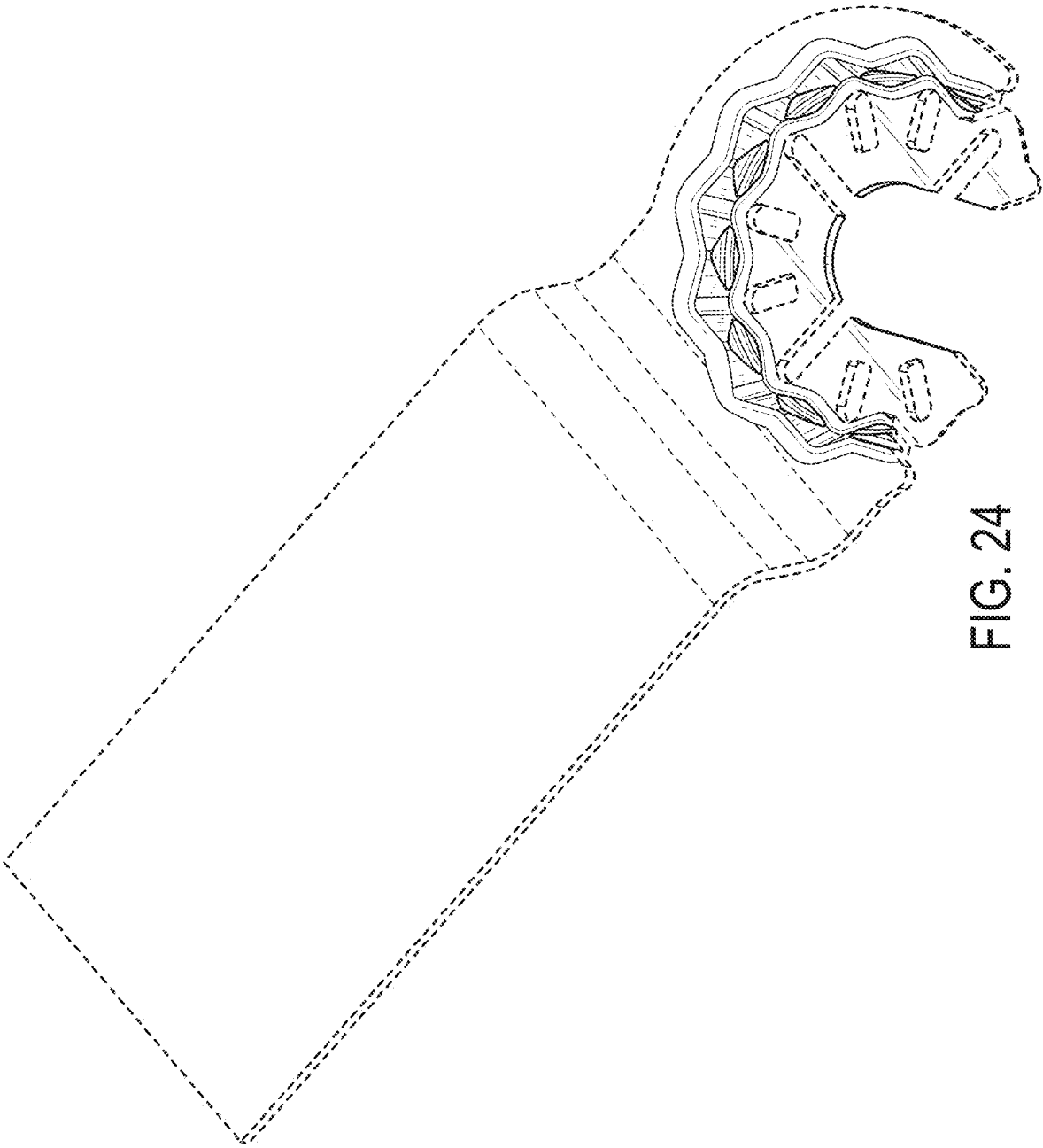

FIG. 24

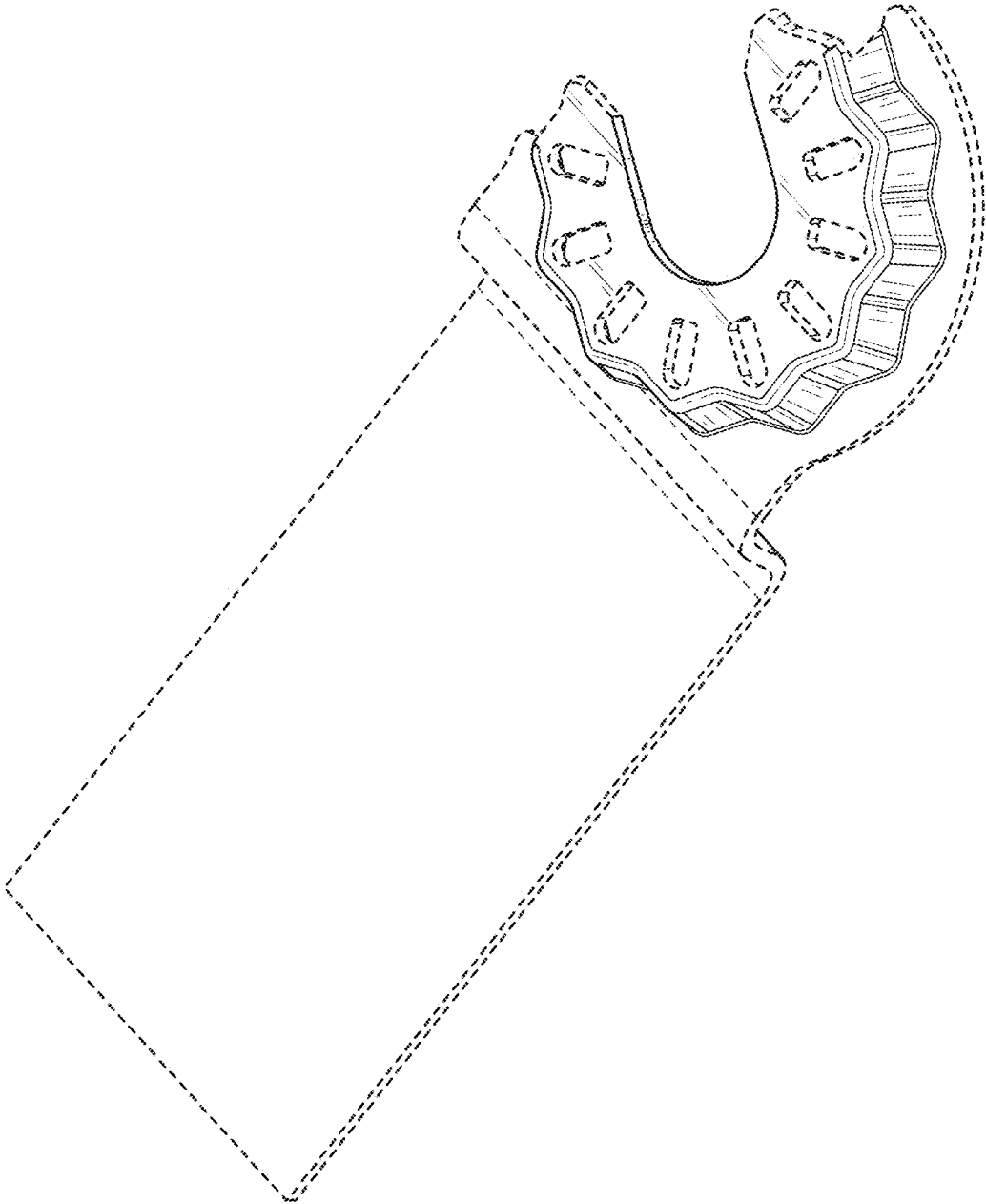

FIG. 25

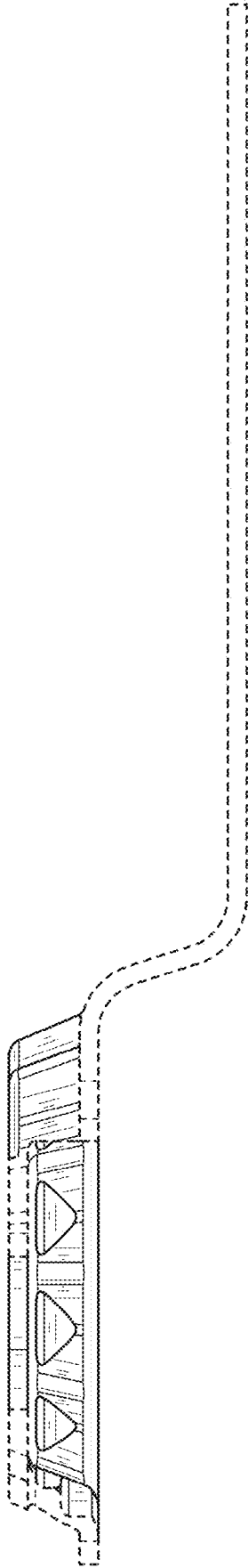

FIG. 26

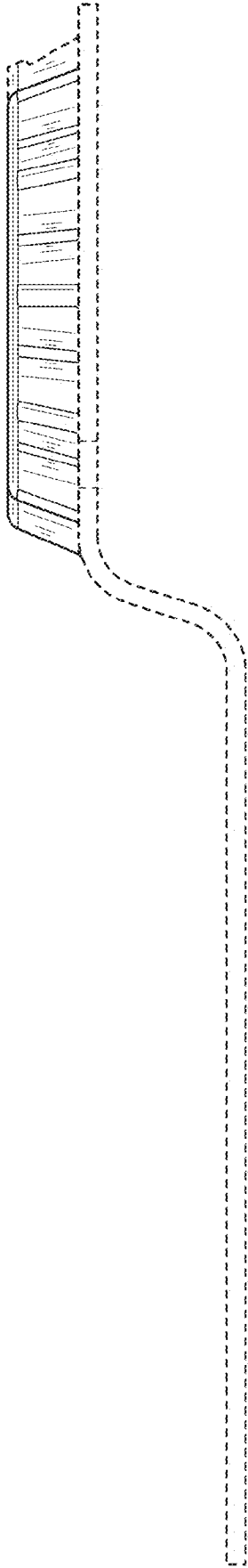

FIG. 27

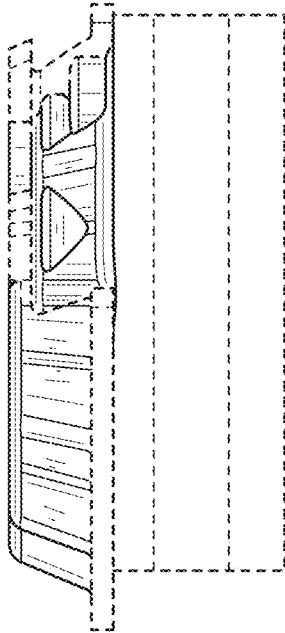

FIG. 28

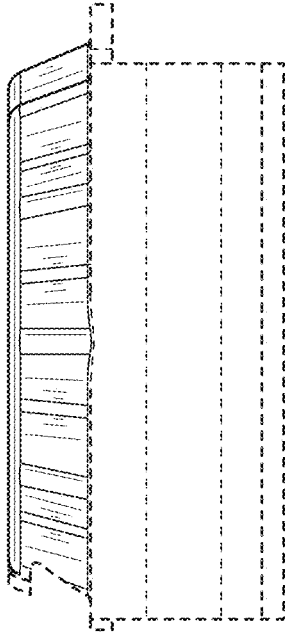

FIG. 29

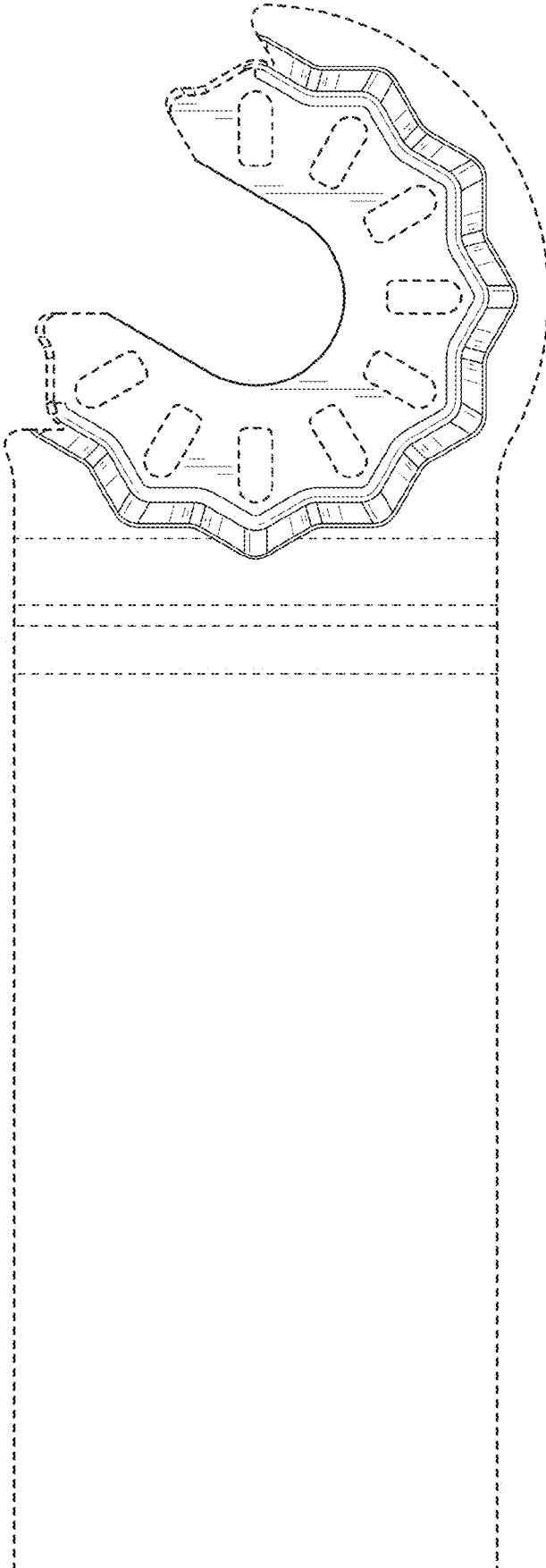

FIG. 30

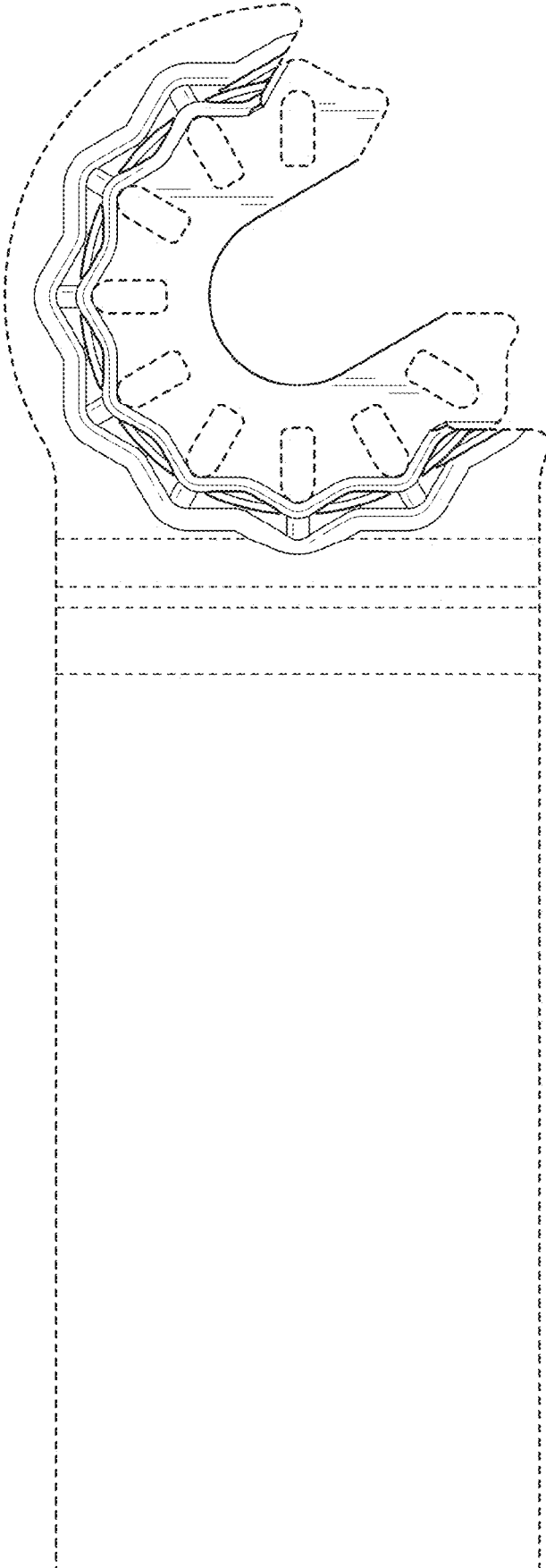

FIG. 31

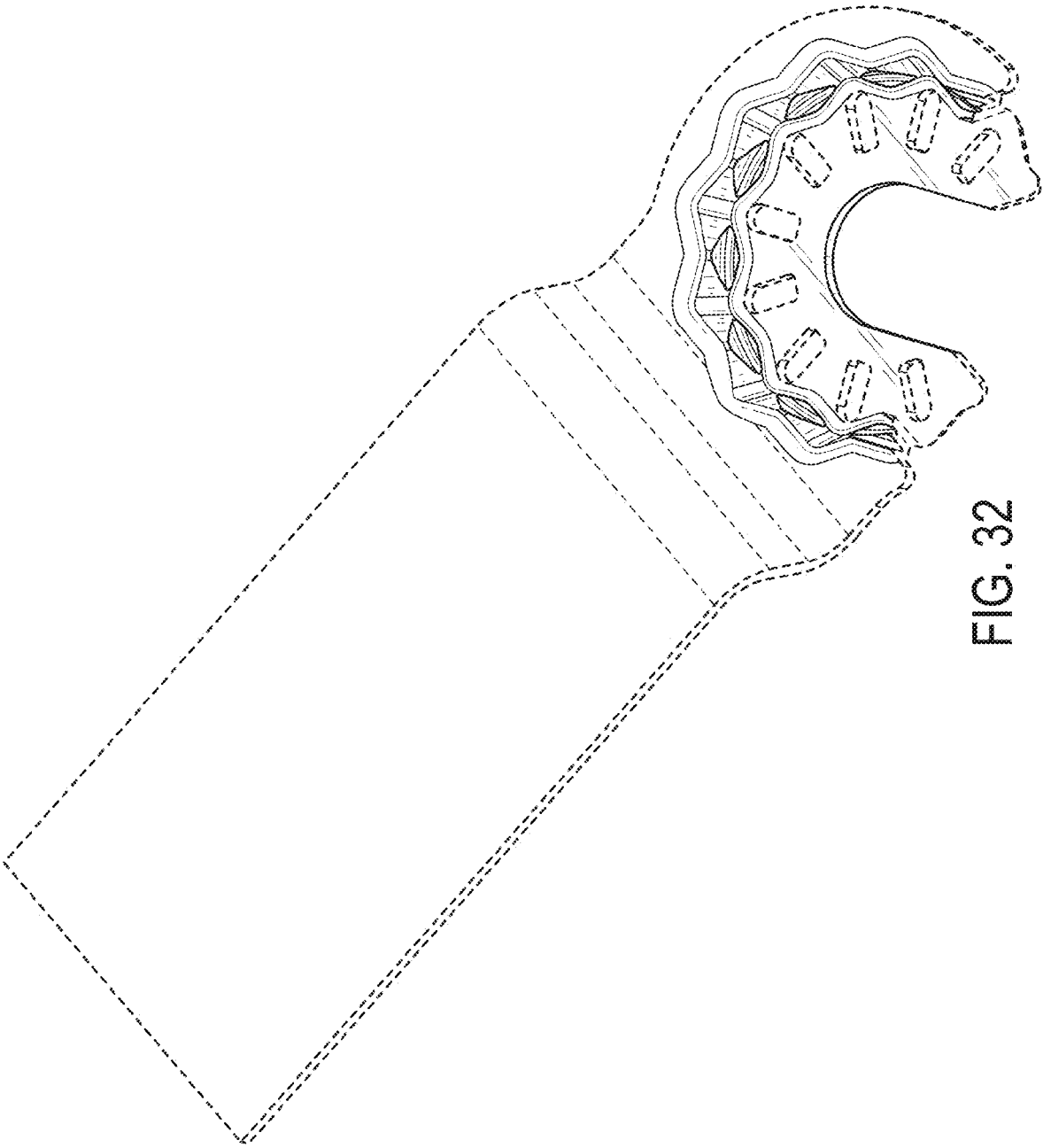

FIG. 32

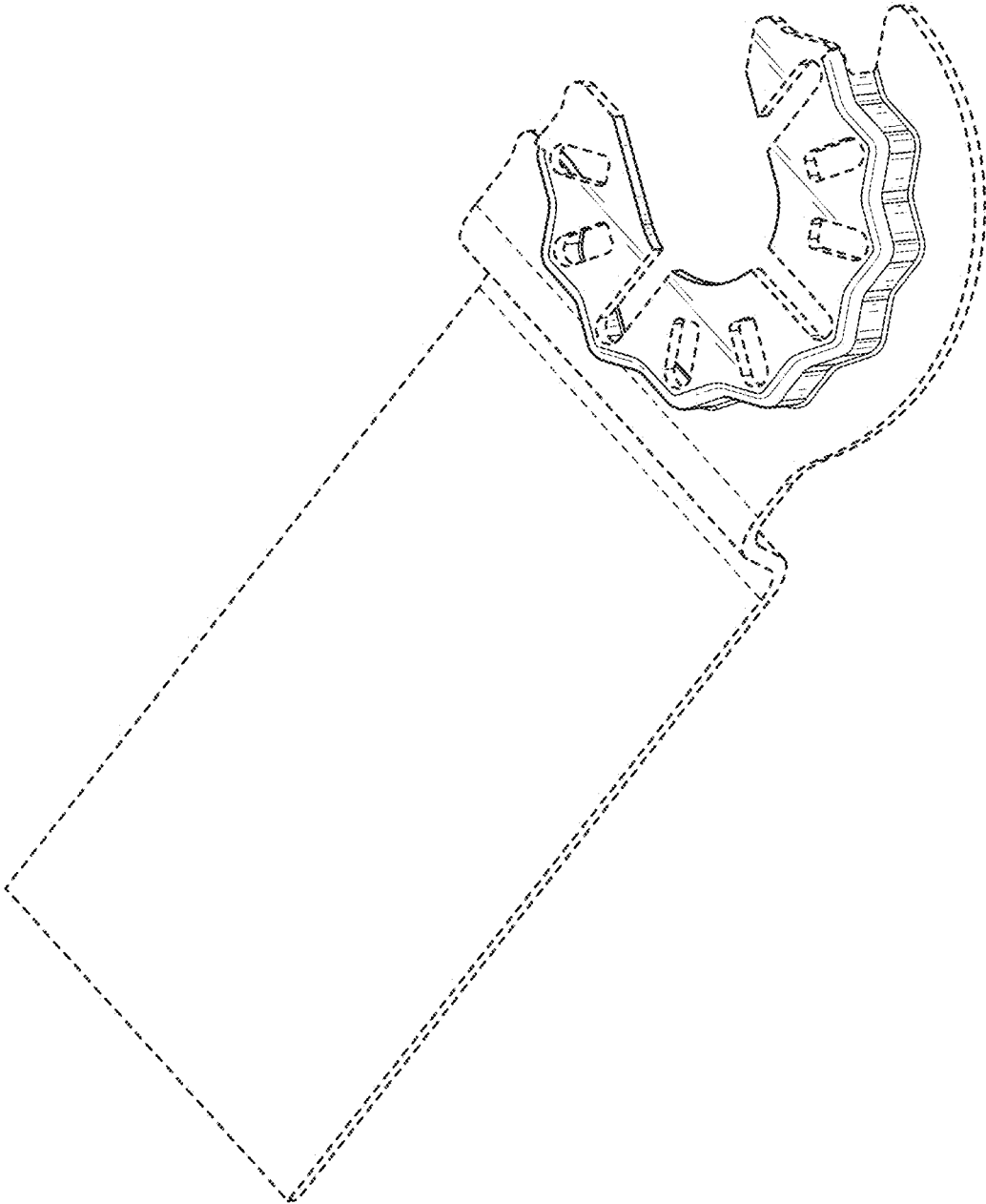

FIG. 33

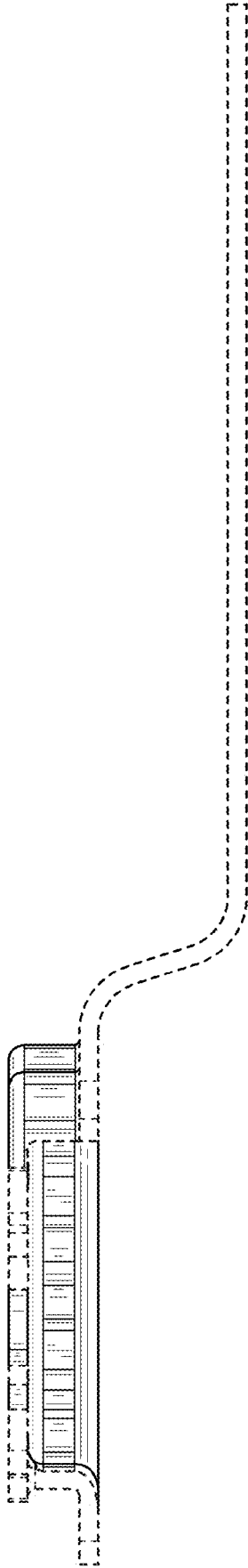

FIG. 34

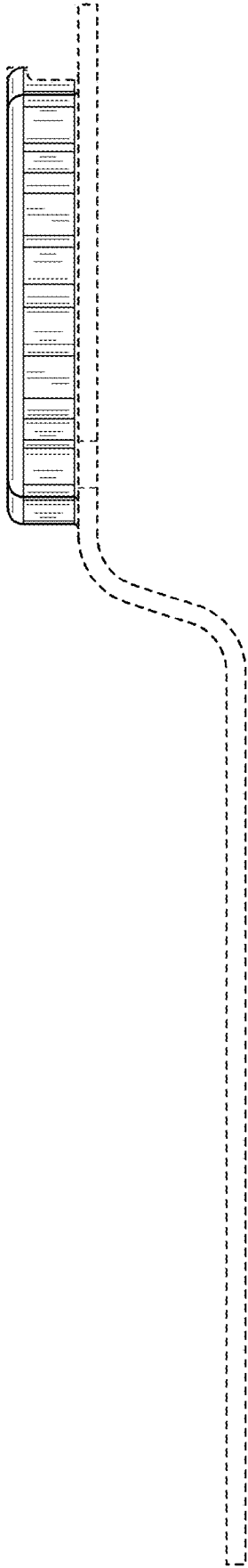

FIG. 35

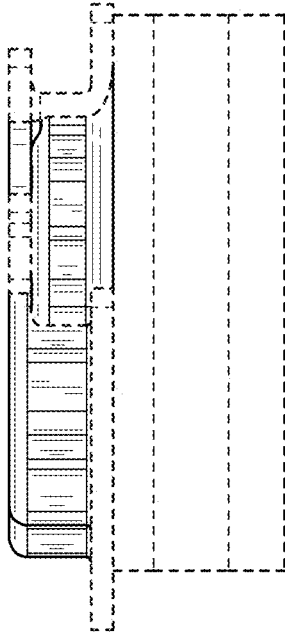

FIG. 36

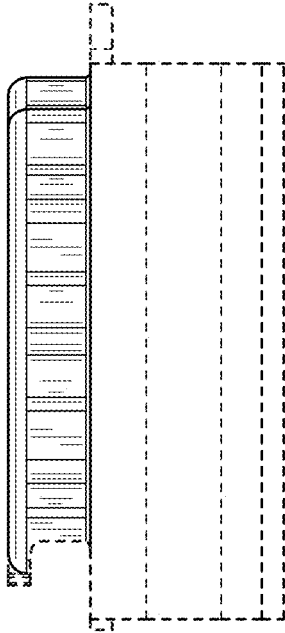

FIG. 37

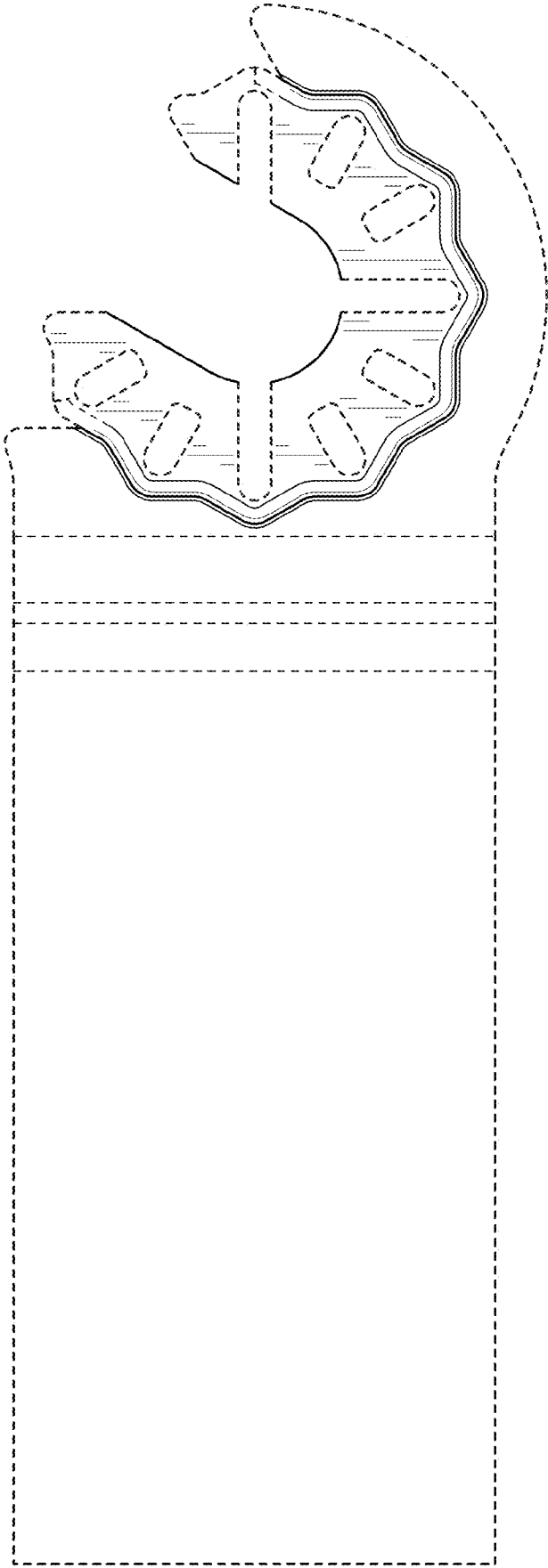

FIG. 38

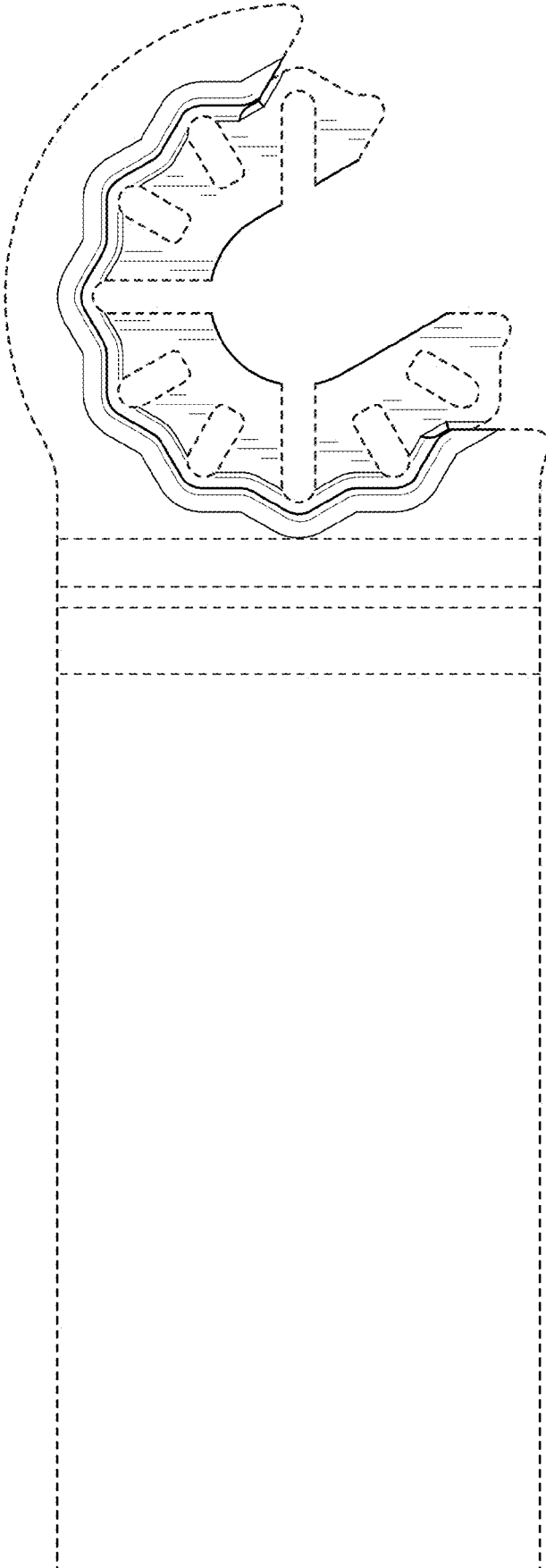

FIG. 39

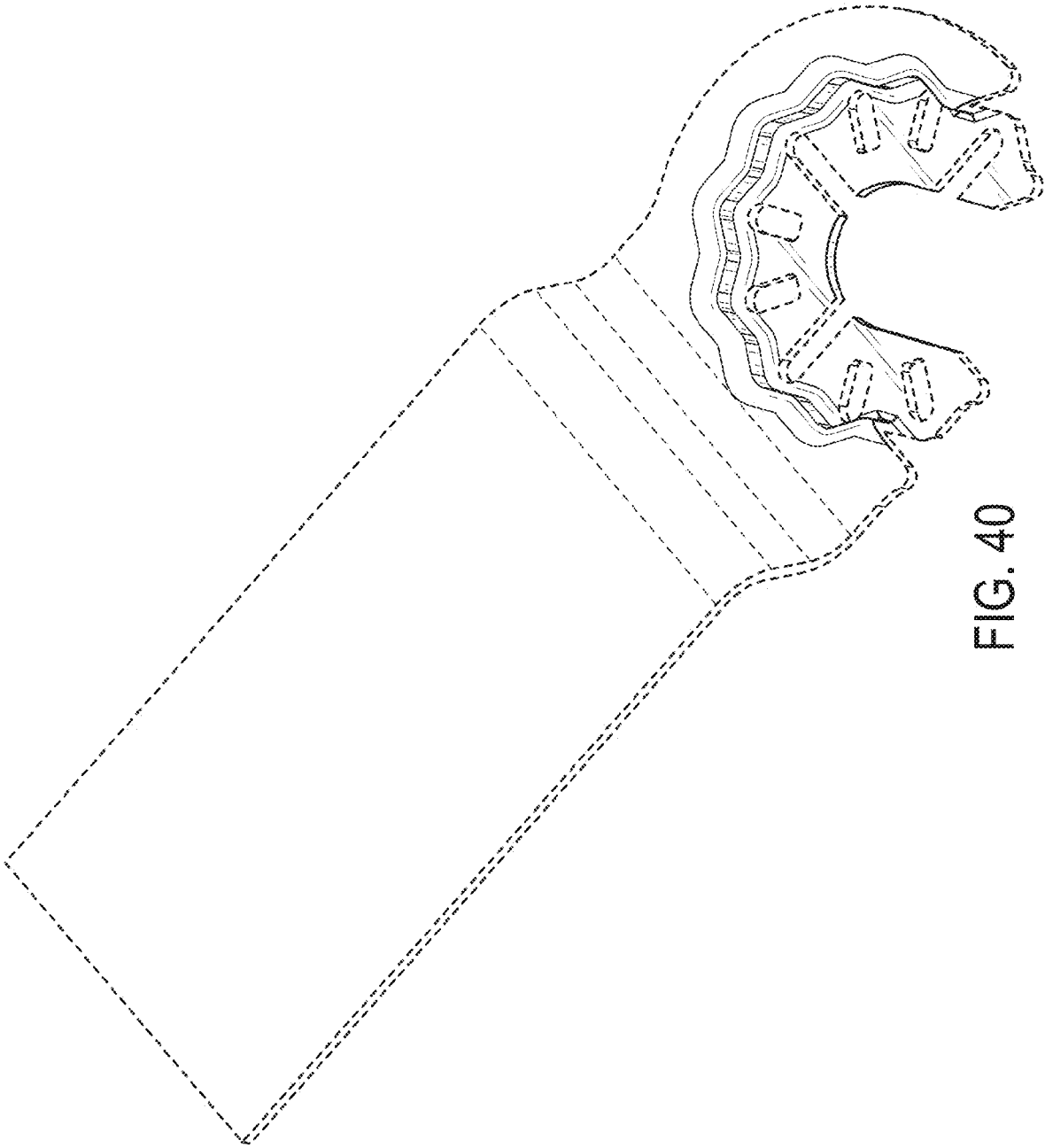

FIG. 40

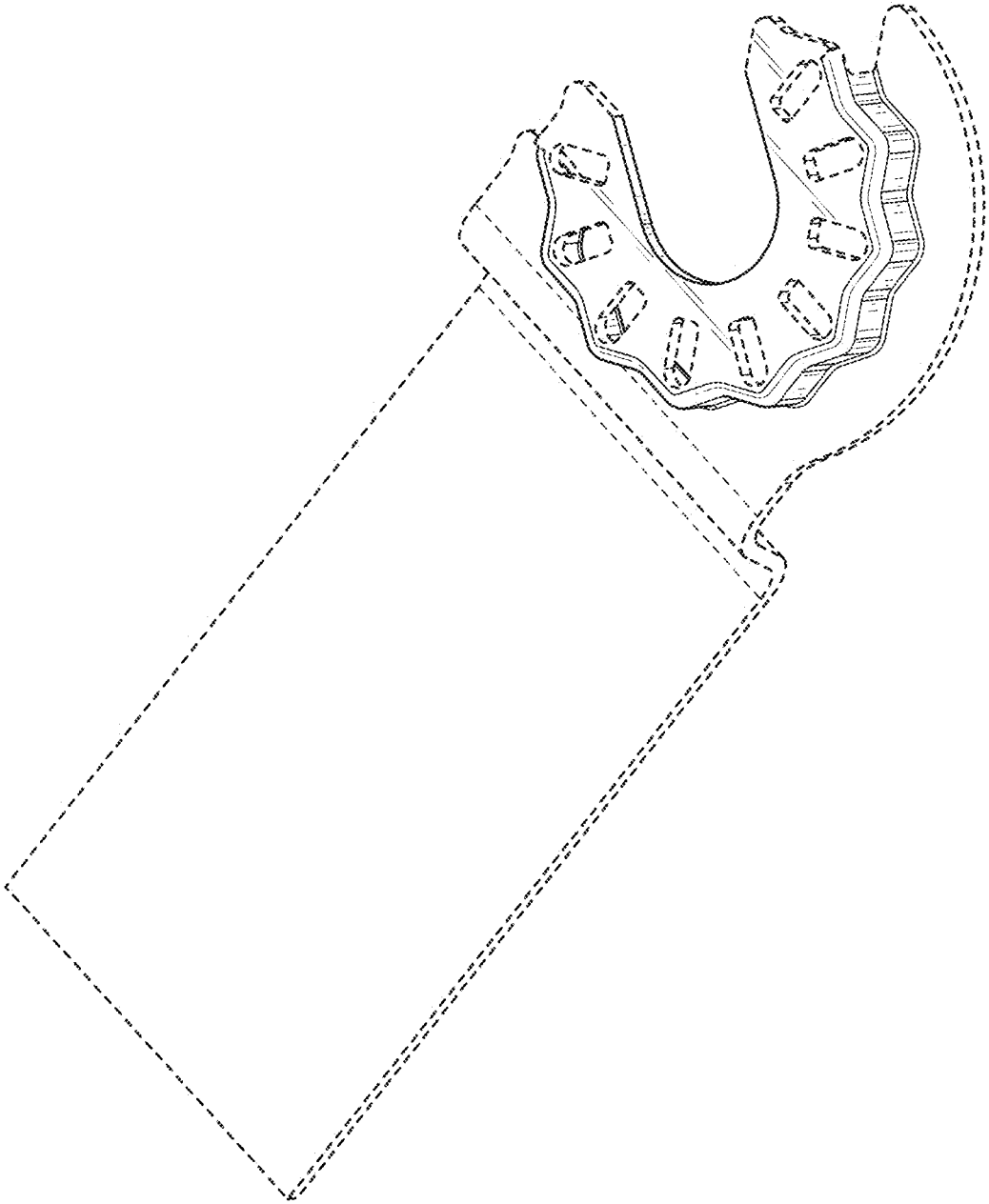

FIG. 41

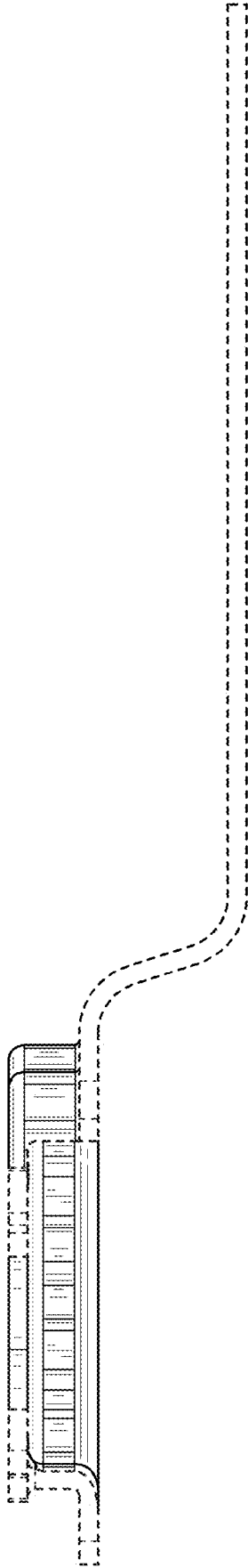

FIG. 42

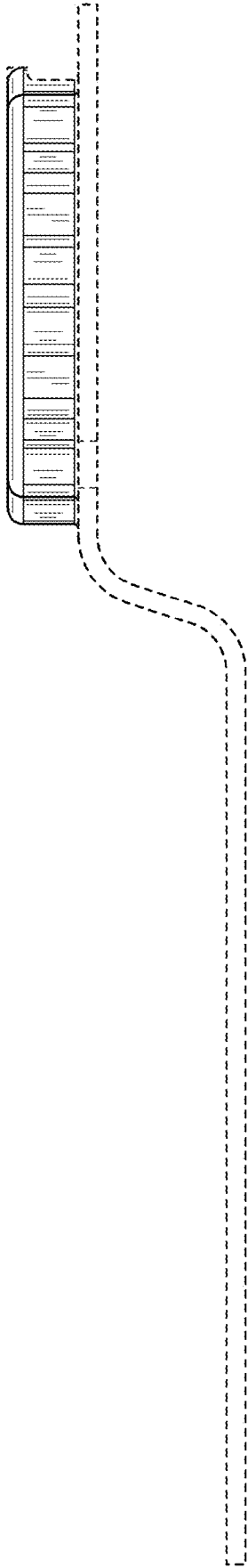

FIG. 43

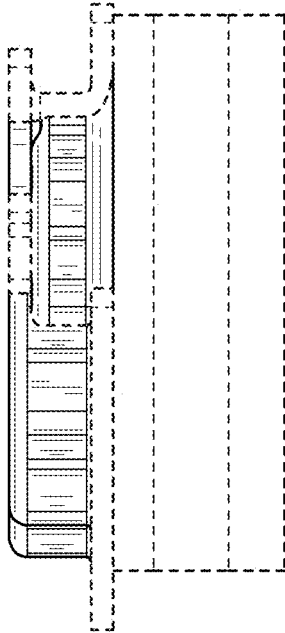

FIG. 44

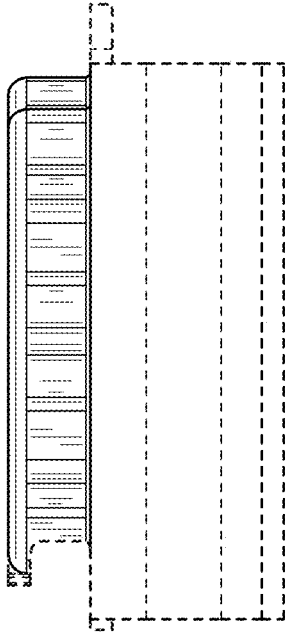

FIG. 45

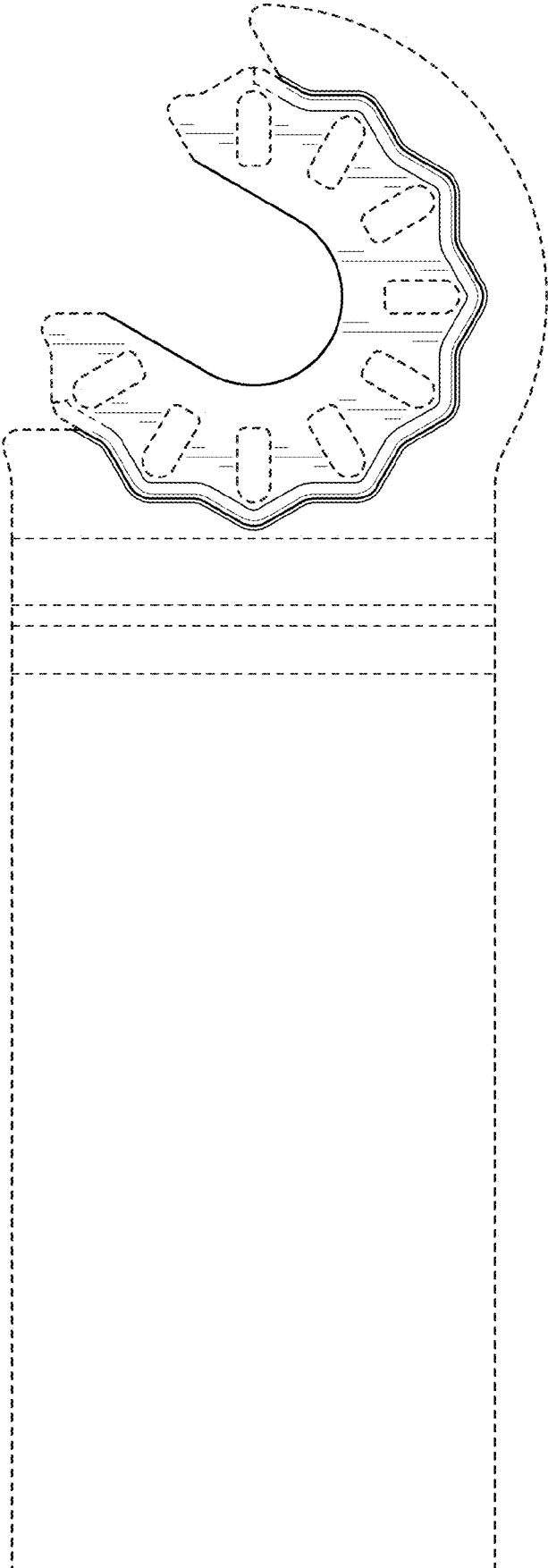

FIG. 46

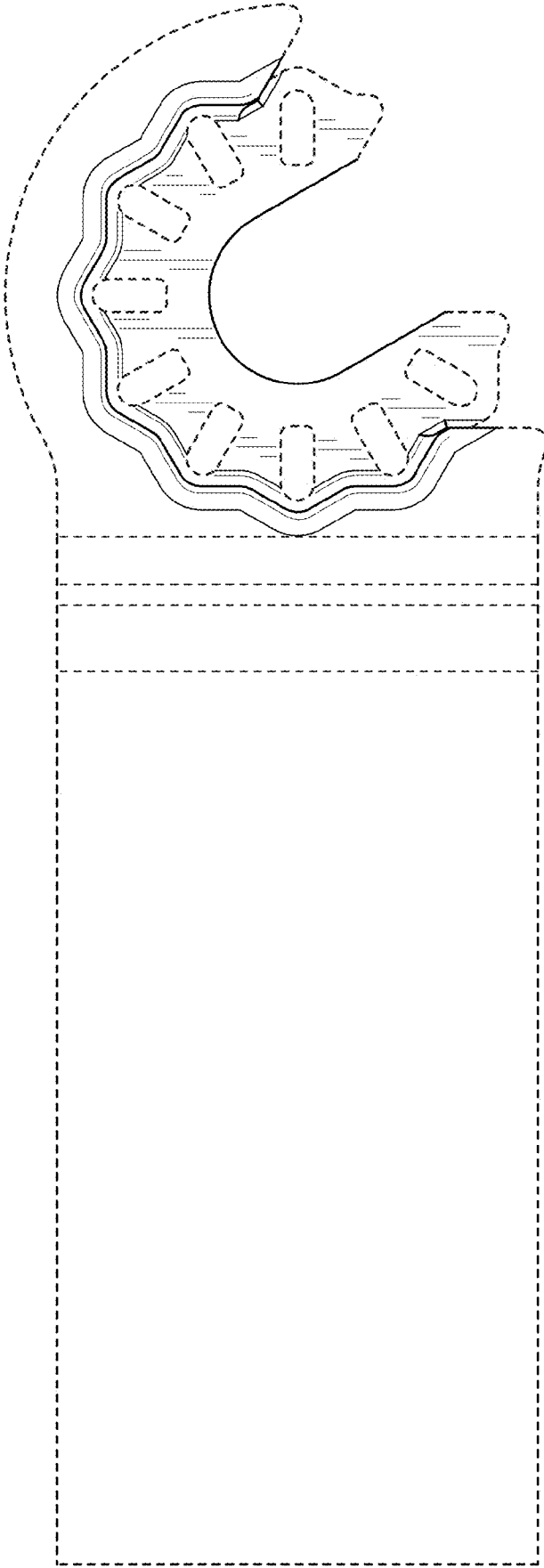

FIG. 47

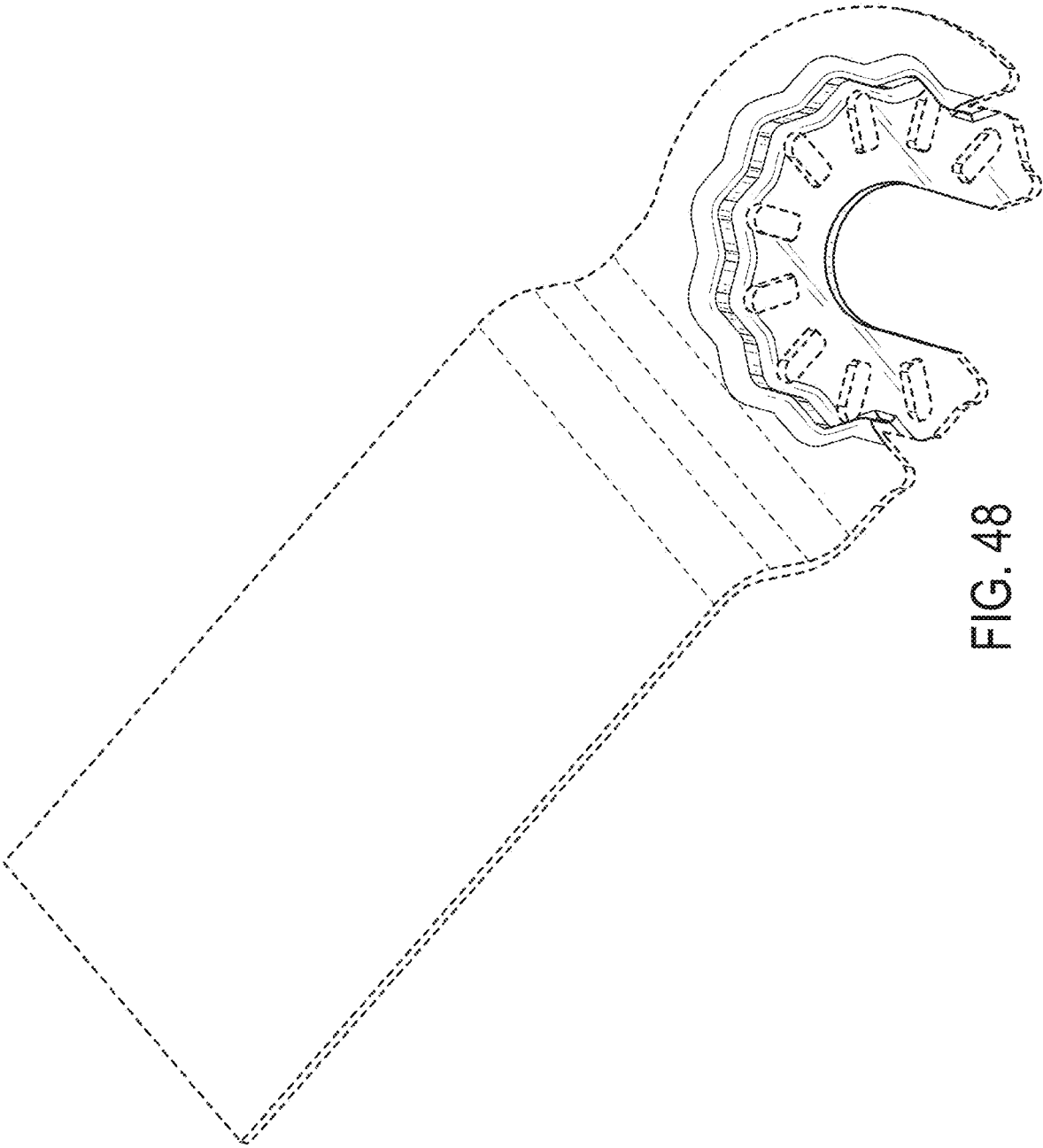

FIG. 48

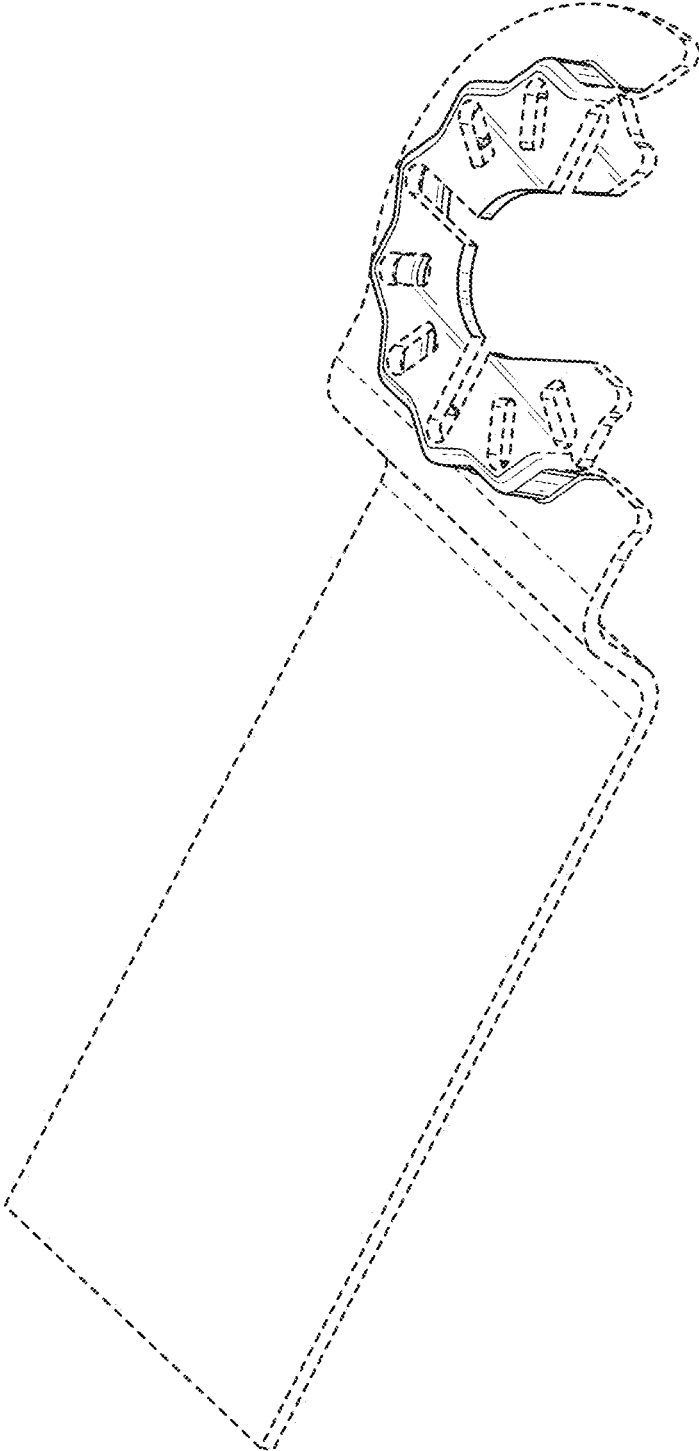

FIG. 49



FIG. 50

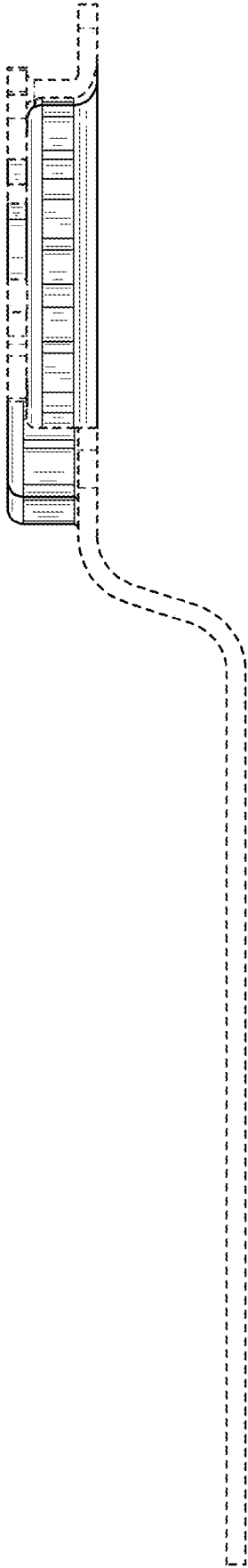

FIG. 51

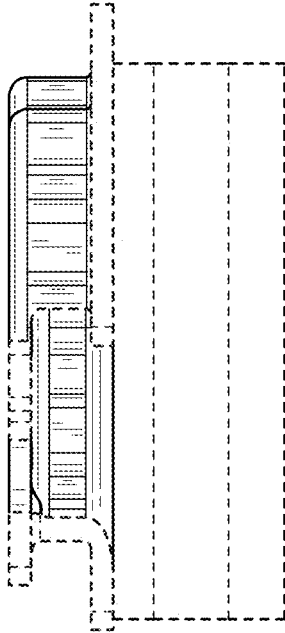

FIG. 52

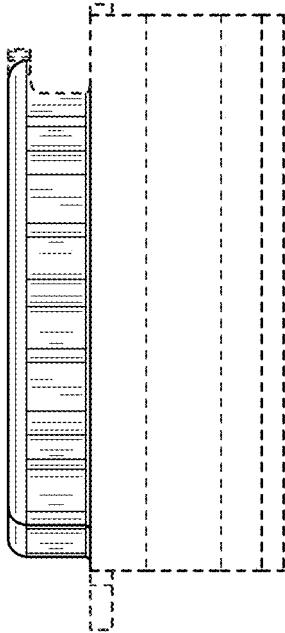

FIG. 53

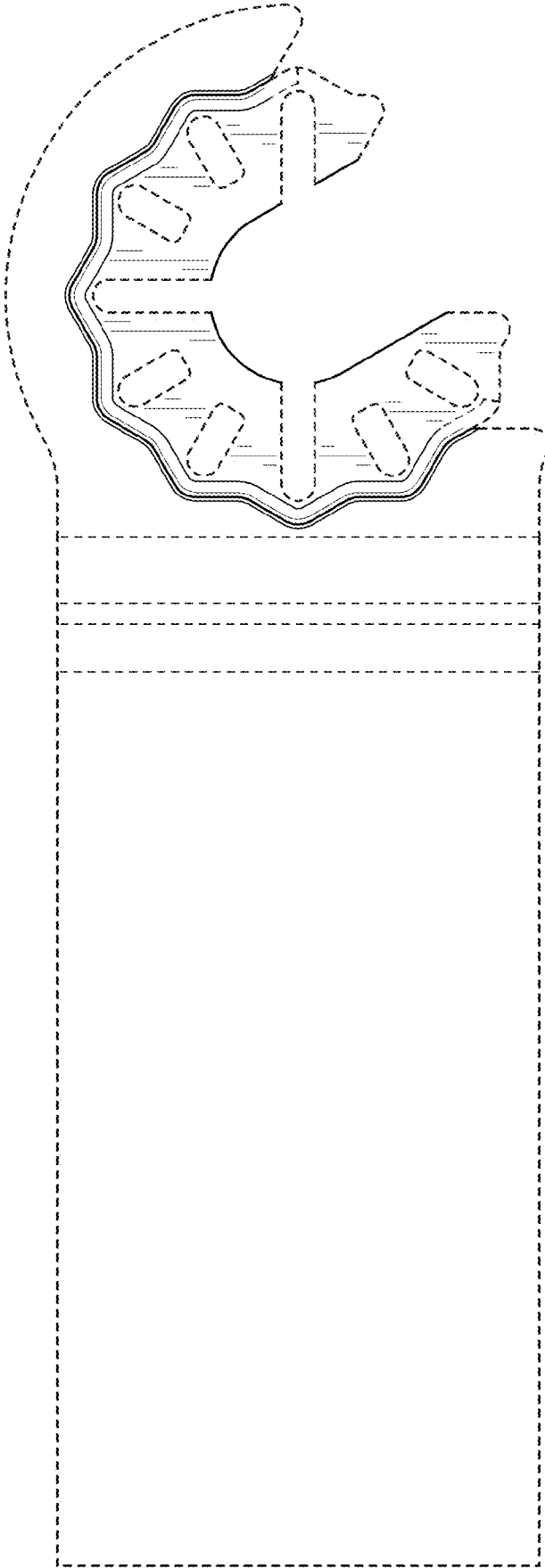

FIG. 54

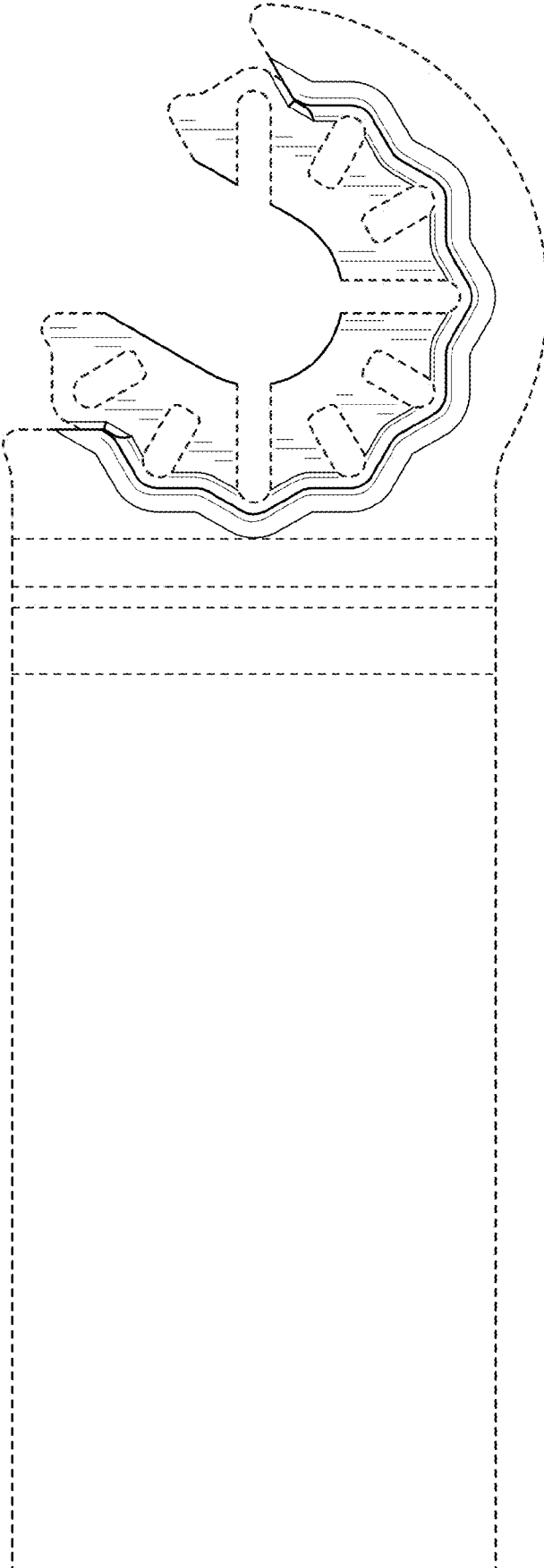

FIG. 55

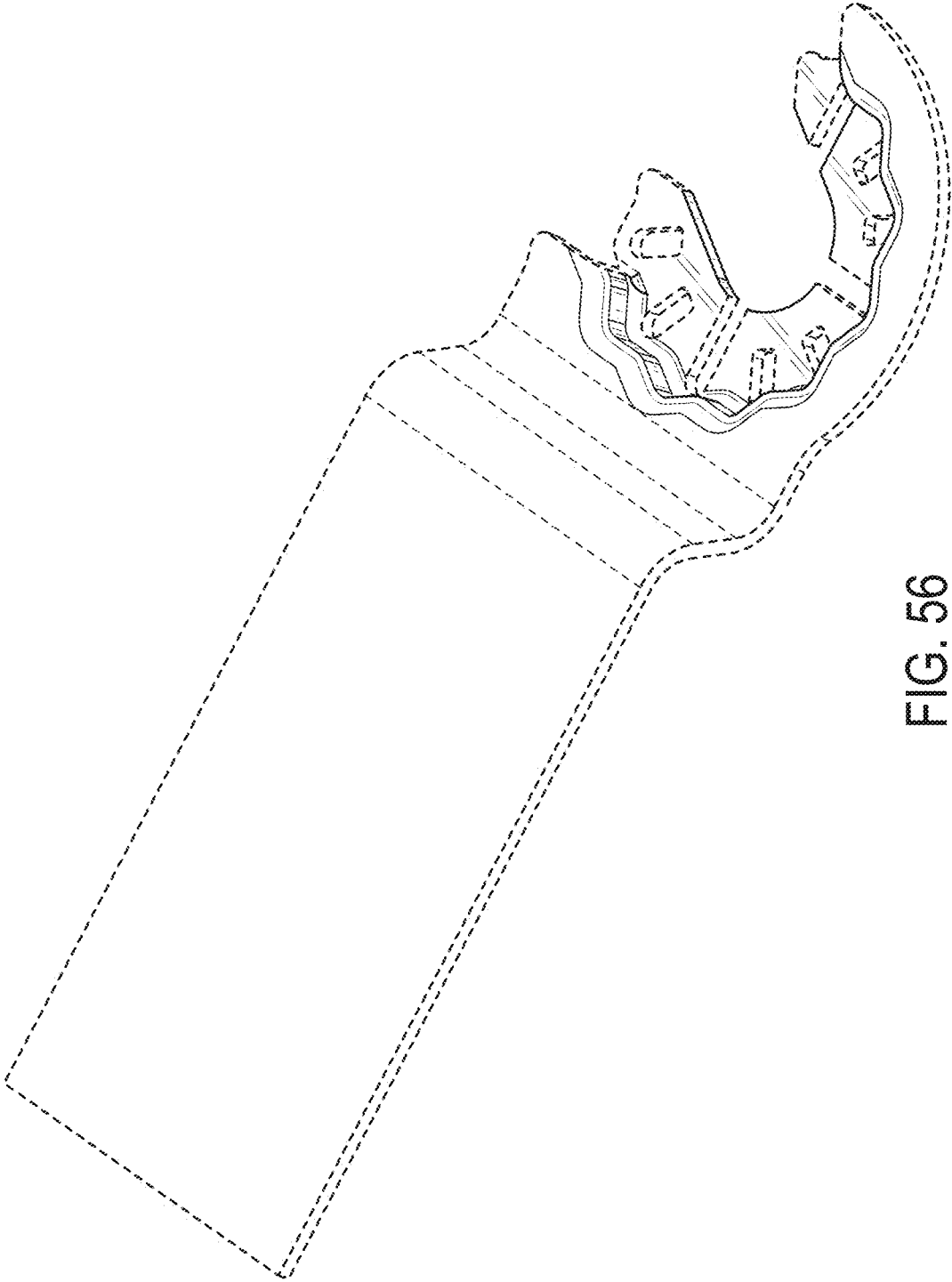

FIG. 56

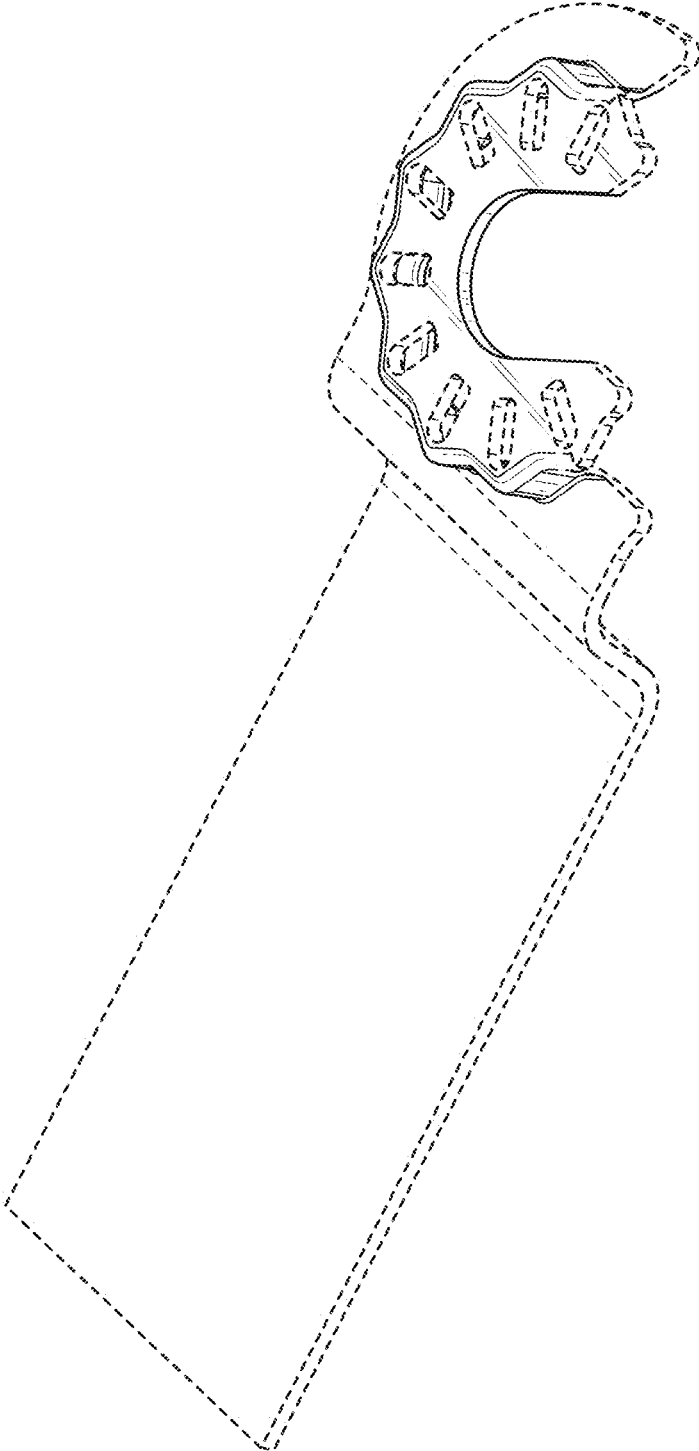

FIG. 57



FIG. 58

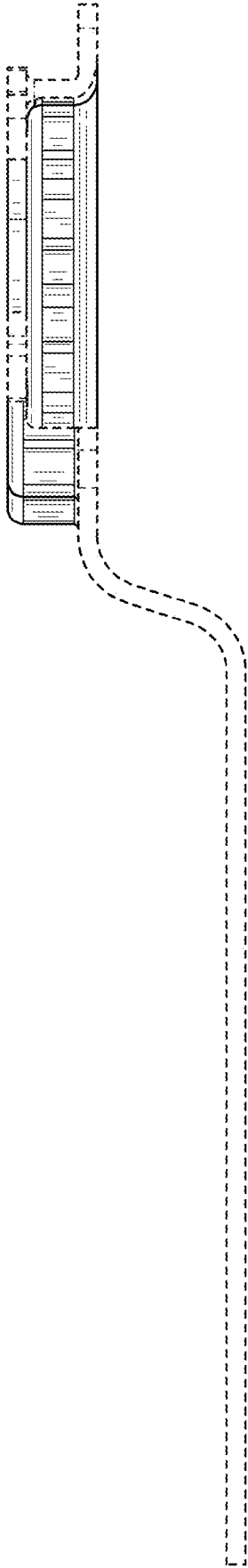

FIG. 59

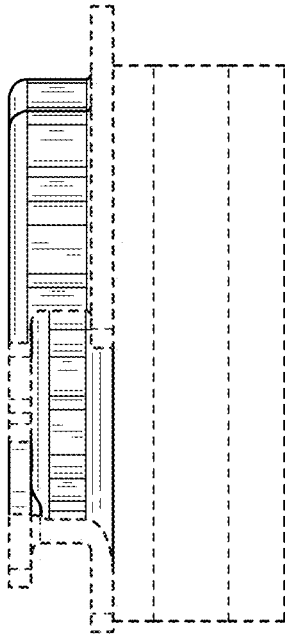

FIG. 60

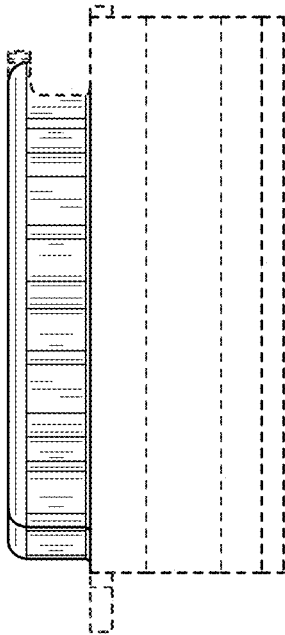

FIG. 61

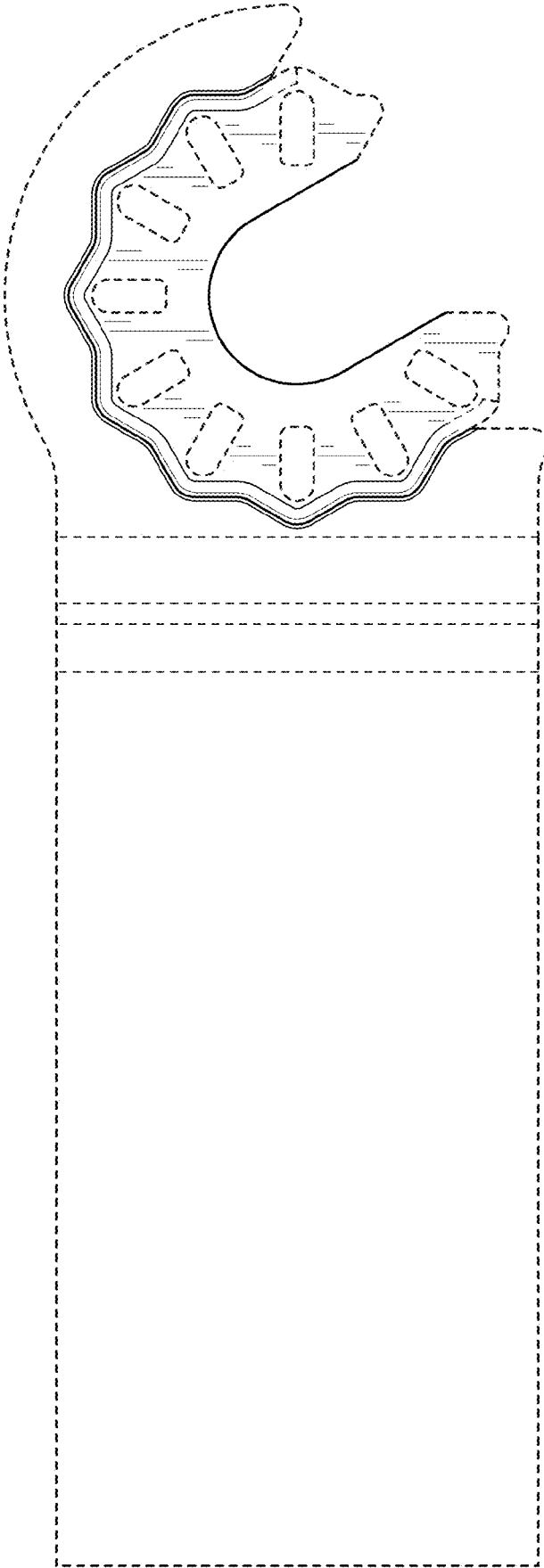

FIG. 62

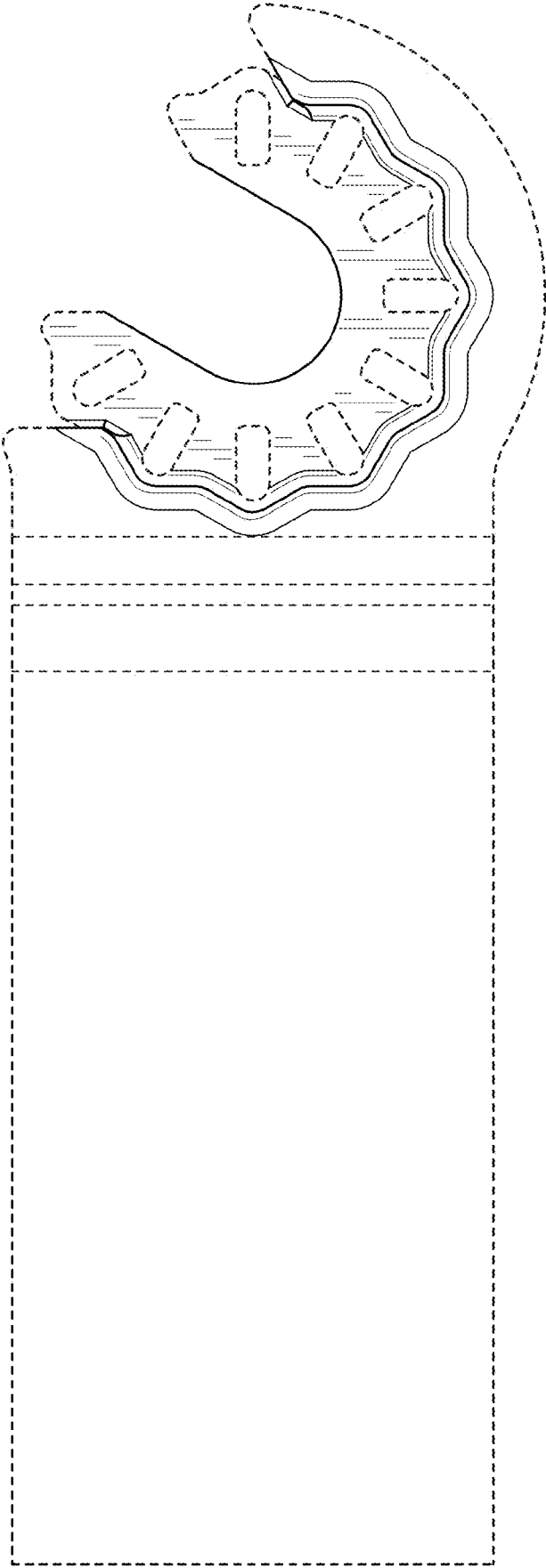

FIG. 63

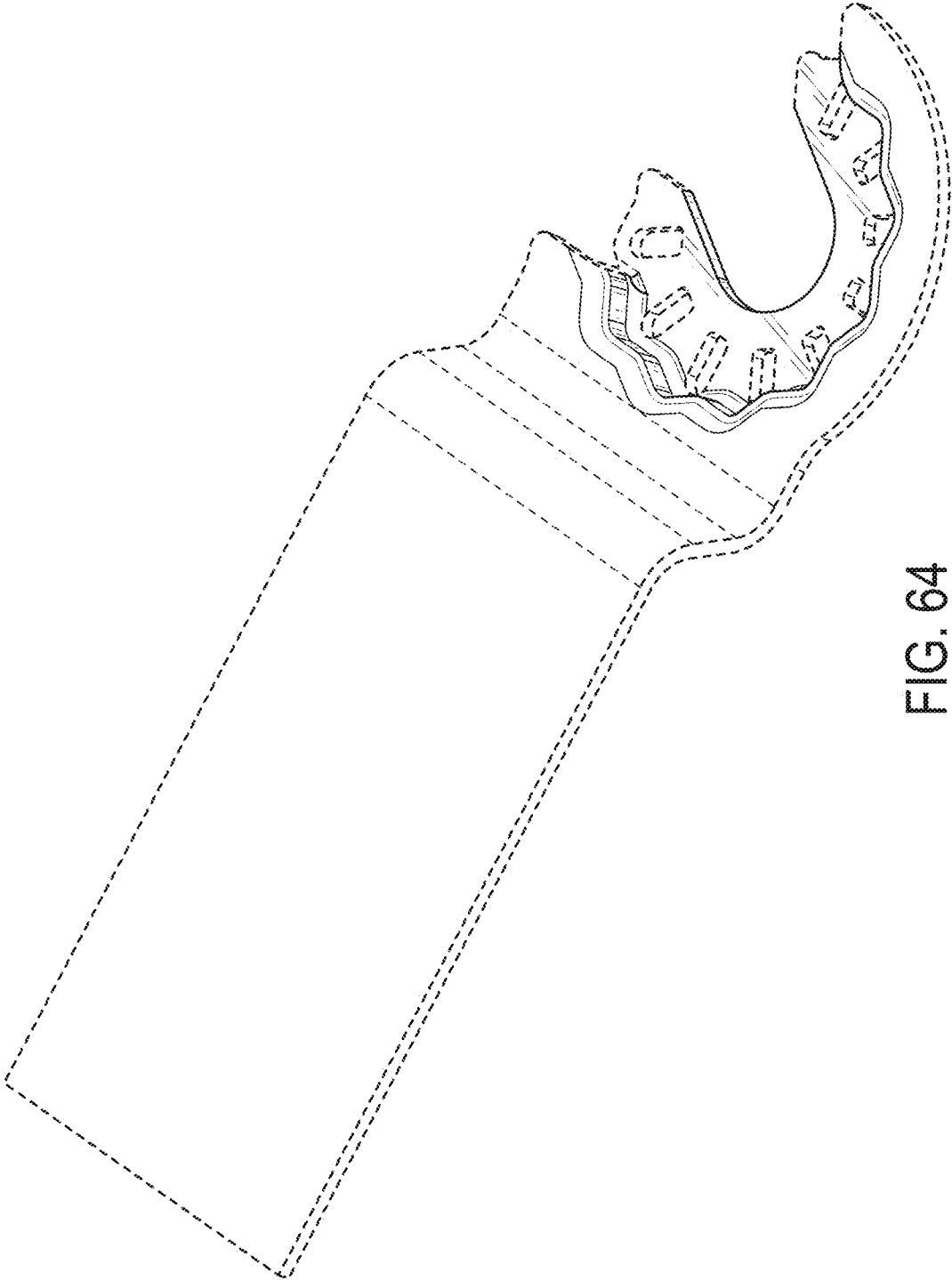

FIG. 64