



## INTERNATIONAL APPLICATION PUBLISHED UNDER THE PATENT COOPERATION TREATY (PCT)

<p>(51) International Patent Classification <sup>5</sup> : <b>A61M 1/00</b></p>	<p><b>A2</b></p>	<p>(11) International Publication Number: <b>WO 92/14496</b> (43) International Publication Date: 3 September 1992 (03.09.92)</p>
<p>(21) International Application Number: PCT/US92/01557 (22) International Filing Date: 24 February 1992 (24.02.92) (30) Priority data: 660,491 25 February 1991 (25.02.91) US (71) Applicant: BAXTER INTERNATIONAL INC. [US/US]; One Baxter Parkway, Deerfield, IL 60015 (US). (72) Inventors: TELANG, Anil, M. ; 25058 LaPlante Way, Saugus, CA 91350 (US). McDOWELL, Douglas, J. ; 1245 Michelle Court, Iowa City, IA 52240 (US). (74) Agents: PIERCE, Kay, H. et al.; One Baxter Parkway, Deerfield, IL 60015 (US).</p>		<p>(81) Designated States: AT, AT (European patent), AU, BB, BE (European patent), BG, BR, CA, CH, CH (European patent), CS, DE, DE (European patent), DK, DK (European patent), ES, ES (European patent), FI, FR (European patent), GB, GB (European patent), GR (European patent), HU, IT (European patent), JP, KP, KR, LK, LU, LU (European patent), MC (European patent), MG, MN, MW, NL, NL (European patent), NO, PL, RO, RU, SD, SE, SE (European patent).</p> <p><b>Published</b> <i>Without international search report and to be republished upon receipt of that report.</i></p>

(54) Title: VACUUM SYSTEM FOR AUTOTRANSFUSION DEVICE

(57) Abstract

A system is described for the collection and re-infusion of fluids from a patient. The system includes a non-disposable rigid cannister (12) and a disposable flexible liner (22) that is placed in the cannister (12). Fluids are collected from a patient in the cannister liner (22). The liner (22) is then removed from the cannister (12) and the contents are re-infused back into a patient. The system is unique in that it provides a stand alone vacuum means for continuously providing a relatively high vacuum to the cannister (12) and a relatively low vacuum inside the liner (22) to cause the liner (22) to expand against the walls of the cannister (12). The stand alone vacuum means also provides a consistent relatively low vacuum to a patient's cavity for collecting fluids from the patient without damaging the patient's internal organs.

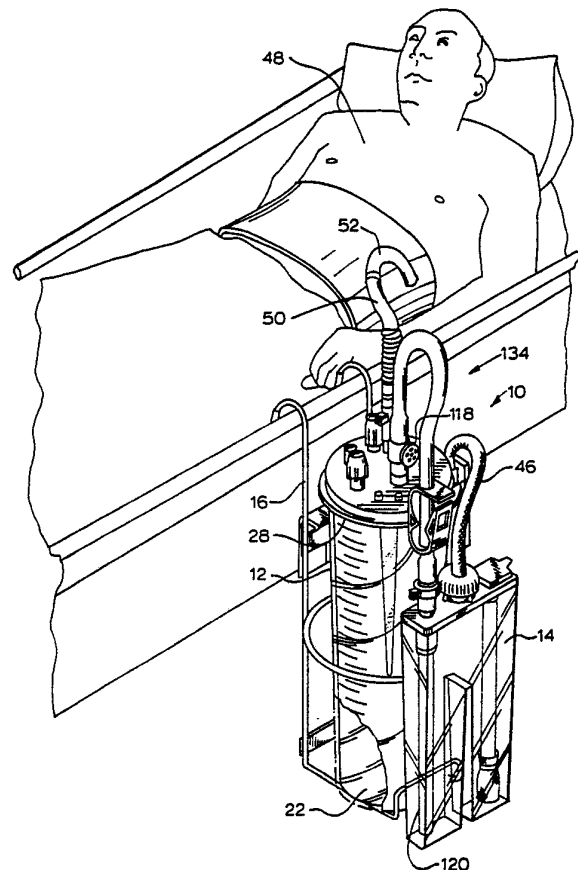

**FOR THE PURPOSES OF INFORMATION ONLY**

Codes used to identify States party to the PCT on the front pages of pamphlets publishing international applications under the PCT.

AT	Austria	FI	Finland	ML	Mali
AU	Australia	FR	France	MN	Mongolia
BB	Barbados	GA	Gabon	MR	Mauritania
BE	Belgium	GB	United Kingdom	MW	Malawi
BF	Burkina Faso	GN	Guinea	NL	Netherlands
BG	Bulgaria	GR	Greece	NO	Norway
BJ	Benin	HU	Hungary	PL	Poland
BR	Brazil	IE	Ireland	RO	Romania
CA	Canada	IT	Italy	RU	Russian Federation
CF	Central African Republic	JP	Japan	SD	Sudan
CG	Congo	KP	Democratic People's Republic of Korea	SE	Sweden
CH	Switzerland	KR	Republic of Korea	SN	Senegal
CI	Côte d'Ivoire	LI	Liechtenstein	SU	Soviet Union
CM	Cameroon	LK	Sri Lanka	TD	Chad
CS	Czechoslovakia	LU	Luxembourg	TG	Togo
DE	Germany	MC	Monaco	US	United States of America
DK	Denmark	MG	Madagascar		
ES	Spain				

**VACUUM SYSTEM  
FOR  
AUTOTRANSFUSION DEVICE**

**FIELD OF THE INVENTION**

5           This invention relates generally to wound drainage systems and more specifically relates to pleural drainage systems in which fluids are being collected in a flexible container which is housed in a rigid cannister.

**BACKGROUND OF THE INVENTION**

10           In the medical field, it is frequently necessary after surgery or after a patient has incurred a trauma to the chest cavity to collect fluids from the chest cavity after the cavity has been closed. This type of fluid collection is commonly referred to as "closed-wound drainage". One particularly important feature of closed-wound  
15 drainage is that it requires a relatively low vacuum to suction fluids from the patient's chest cavity. If higher vacuums are used, damage to the internal organs may occur. Typical vacuum ranges of 20-30 cm. H<sub>2</sub>O are used to collect fluids from a closed chest or pleural cavity.

20           Systems have been developed in the past which are specifically used to collect such fluids. One goal in suctioning or draining fluids from a chest cavity is to insure that air is not inadvertently returned to the chest cavity through the tube which is draining fluids from the patient. Accordingly, it is desirable to provide a one-way check valve  
25 or other system to insure one-way flow of fluids and gases from the patient to a collection container.

          Various systems have been used in the past to collect fluids from

a chest cavity. One system uses a rigid cannister with a flexible liner. In this particular system, the vacuum applied to the inside of the liner is equal to the vacuum applied between the liner and the cannister. One problem with this system is that the liner may not completely expand to fit the inside of the cannister. If the liner is folded inside the cannister, it is difficult for medical personnel to accurately monitor the amount of fluids that are collected in the liner. Therefore, a need exists to provide a system which insures that the liner completely expands within the cannister to rest against the walls of the cannister to allow medical personnel to more readily view and measure the contents of the fluids in the liner.

Another system has been developed which uses a rigid cannister and a flexible liner but which applies a high-vacuum between the cannister and the liner when the system is initially put together to be used. Once the bag is expanded, the high-vacuum source is removed from the cannister and a low-vacuum source is applied to the inside of the liner. In this system, an elastomer check valve is provided to prevent leakage of the high-vacuum between the liner and the cannister. However, in some instances, leakage may occur. This leakage will allow the liner to collapse upon itself as the low-vacuum is applied to the inside of the liner to suction fluids from a patient. When this occurs, it is necessary for medical personnel to re-apply a high-vacuum source to the space between the liner and the cannister. This has been considered to be a nuisance and it is, therefore, accordingly desirable to develop a new system which does not require the re-application of a high-vacuum between the liner and the cannister.

Another goal in pleural drainage systems is to insure that any accidental high-vacuum present in the liner of a pleural drainage system is not introduced to the patient's pleural cavity. An accidental high-vacuum in the liner may occur when medical personnel performs "milking" of the drainage tube between the patient and the liner. Milking is the act of releasing clots formed in the drainage tube by sequentially squeezing and pulling sections of the tube to force clots that exist in the tube down into the liner. This action may inadver-

tently cause a temporary high vacuum to exist in the liner and thus exist in the drainage tube. Therefore, a need exists to provide a system which has a sensing mechanism for determining when the vacuum in the liner exceeds a pre-determined level.

5

### SUMMARY

A system is described for collection of fluids from a patient for possible re-infusion into the patient. The system includes a rigid cannister having walls which form a cavity. The cannister also has a top opening. A hollow liner is also provided for insertion into the  
10 cavity of the cannister. The liner receives fluids from the patient. The liner includes a cover for attaching the liner to the top of the cannister. The liner also includes a flexible body that has upper and lower portions. The upper portion is attached to the cover. The liner also includes a bottom portion which is attached to the lower portion  
15 of the body of the liner. The flexible body of the liner and the bottom portion of the liner are shaped to generally conform to the walls of the cannister when the flexible body and bottom portion of the liner are located within the cavity of the cannister. The system also includes a vacuum means for continuously providing a relatively high vacuum to  
20 the cavity of the cannister and a relatively low vacuum inside the liner when the liner is located in the cavity to cause the liner to expand against the walls of the cannister. The system also includes a drainage means for providing fluid communication between the inside of the liner and the patient.

25

### BRIEF DESCRIPTION OF THE DRAWINGS

FIG. 1 is a perspective view of the preferred embodiment of a closed-wound drainage autotransfusion system;

FIG. 2 is a perspective view of a liner and cannister of the preferred embodiment of the invention as the liner is inserted into the  
30 cannister;

FIG. 3 is a side view of a liner;

SUBSTITUTE SHEET

FIG. 4 is a perspective view of the preferred cannister and liner;

FIG. 5 is a perspective view of a re-usable cannister showing a vacuum connection to the cavity of the cannister;

5 FIG. 6 is a cut-away view of the control module taken along lines 6-6 in FIG. 7;

FIG. 7 is a top view of the control module;

FIG. 8 is a side view of a valve used in the preferred embodiment of the invention;

FIG. 8 is a front view of the valve illustrated in FIG. 8;

10 FIG. 10 is an illustration of a drainage straw used in one embodiment of the invention;

FIG. 11 is a perspective view of a tray for storing and transporting a control module; and

15 FIG. 12 is a perspective view of a control module located in the tray of FIG. 11 in the upright position to allow fluid to be added to the control module.

## DETAILED DESCRIPTION

### OF THE

### PREFERRED EMBODIMENT

20 Refer now to FIG. 1 which is a perspective view of the preferred embodiment of a closed-wound drainage autotransfusion system 10. As can be seen in the figure, the system 10 includes a cannister 12 and a control module 14. The cannister is located in a hanger 16. The control module 14 is also mounted on the hanger 16. The can-  
25 nister 12 includes walls 18 which form a cavity 20 as can be seen in FIG. 2. The system includes a hollow liner 22 for insertion into the cavity 20 of the cannister. The purpose of the liner 22 is to receive

fluids and gases from the pleural cavity of the patient. The liner 22 includes a cover 24 that is attached to the top 26 of the liner 22. The cover 24 and liner 22 are sealed to one another to form a fluid and gas-tight seal. The cover 24 can be attached to the top 28 of the  
5 cannister 12 as can be seen in FIG. 1.

Referring now to FIG. 3, the liner 22 includes a flexible body 30. The flexible body 30 has upper and lower portions 32 and 34. The upper portion 32 is attached to the cover 24. The lower portion 30 is attached to a bottom 36. The flexible body 30 and the bottom 36 are  
10 shaped so as to generally conform to the walls 18 of the cannister 12. Therefore, when the flexible body 30 and the bottom 36 are inserted into the cavity 20 as illustrated in FIG. 2, the liner 22 will fit snugly against the walls 18 of the cavity 20 of the cannister 12 as illustrated in FIG. 4.

15 In the preferred embodiment, the system 10 includes a vacuum means for continuously providing a relatively high vacuum to the cavity 20 of the cannister 12 and a relatively low vacuum inside the liner 22 when the liner 22 is located in the cavity 20 to cause the liner to expand against the walls 18 of the cannister 12. The vacuum means  
20 includes a "T"-shaped port 38 as illustrated in FIG. 5. The port 38 includes a lower leg 40 which can be connected to a high-vacuum source. The high-vacuum source is typically a vacuum-source provided in the wall of a hospital next to a patient's bed. In many hospitals, this source of high-vacuum tends to provide a vacuum in the  
25 range of 0-760 mm. Hg. This vacuum may vary unexpectedly. However, the vacuum is generally sufficient to cause the flexible body 30 to expand against the walls 18 of the cannister 12 when the vacuum is applied through a middle leg 42 of the "T"-shaped port 38. The middle leg 42 is in fluid communication with the cavity 20 of the  
30 cannister 12 to allow the high vacuum source to be applied to the cavity 20. The "T"-shaped port 38 also includes an upper leg 44 which is attached to a braided tube 46 which will be discussed in greater detail below.

The vacuum means which provides a relatively low vacuum to the inside of the liner 22 must provide this vacuum at a constant relatively low level. The reason why the vacuum provided to the inside of the liner 22 must remain constant is that variations in the vacuum in the liner are transmitted to the patient 48 via a drainage tube 50 which is connected to a chest tube 52 as illustrated in FIG. 1. Thus, if a high vacuum is applied to the inside of the liner 22 the same vacuum will be applied to the chest cavity of the patient 48. This can injure the patient's internal organs. Also, variations in vacuum can injure the patient's organs even if the vacuums are relatively low. Therefore, the high vacuum present in braided tube 46 is transmitted into control module 14 for transforming the variable high vacuum into a constant low vacuum. The control module 14 is illustrated in greater detail in FIG. 6.

As can be seen in FIG. 6, the control module 14 includes a first suction control chamber 54 for transforming the variable high vacuum into a constant low vacuum. When the module 14 is in use, the chamber 54 is partially filled with a sterile fluid 56. The first chamber 54 include a first tube 58 that is located within the first chamber 54. The first tube has first and second ends 60 and 62. The first end 60 is the immersed in fluid 56 and the second end 62 extends above the top of the fluid 56 in the first chamber. The second end 62 is attached to a lid 66 which covers the top 64 of the first chamber 54. The lid 66 includes a port 68 which is located immediately above the top 64 of the first chamber 54. The second end 62 of the first tube 58 is in sealed engagement with the port 68. The port is partially covered by a cap 70. A narrow air space 72 exists between the cap 70 and the port 68 to allow atmospheric air pressure into tube 58. The high-vacuum-source present in braided tube 46 is attached to a cap 74 which is located on a high-vacuum port 76 on lid 66. The port 76 provides a first path 78 between the high-vacuum source and a second chamber 80 in the control module 14. The lid 66 and the control module 14 are shaped in such a way that when the lid 66 is placed on the control module 14 a second path 82 is formed between the first and second chambers 54 and 80. The second path is a



relatively narrow path that provides fluid communication between the first and second chamber 54 and 80. Thus, the high vacuum provided to the second chamber 80 through port 76 is also transmitted to the first chamber 54. The high vacuum causes atmospheric air present in tube 58 to be pulled through the first end 60 of the tube against the first column 56 of fluid. The resistive force of the water pressure against the air as it is drawn through the water column creates a relatively low back pressure which is proportional to the height of the column of water. This reduces the vacuum present in the upper portion of the chamber 54 to a relatively low, constant vacuum which can be controlled simply by controlling the height of the column of fluid. Therefore, the first chamber 54 acts as a pressure regulator which transforms a variable high vacuum into a constant relatively low vacuum.

The control module 14 includes a second chamber 80 which provides a water-based one-way check valve. This chamber will now be discussed in greater detail. The chamber 80 includes a second tube 84 which is located within the chamber. The second tube 84 includes first and second ends 86 and 88. The first end 86 is immersed in sterile fluid when the module 14 is in use. In the preferred embodiment, the second chamber 80 is partially filled with 2 cm. high of sterile fluid. The second end 88 of the second tube 84 is attached to a vacuum-interface port 80 on lid 66. The vacuum-interface port 80 is located over the upper portion 82 of the second chamber 80. The vacuum-interface port 80 has one end 84 connected to a vacuum-interface tube 86 which will be discussed in greater detail below. The vacuum-interface tube 86 is in fluid communication with the inside of the liner 22. As discussed above, the vacuum present within the liner 22 is in fluid communication with the cavity of a patient 48 through tubes 50, 52. Therefore, the vacuum present in the first and second chambers 54, 80 of the control module 14 is also the same vacuum that is provided to the cavity of the patient 48.

The purpose of the second chamber 80 of the control module 14

SUBSTITUTE SHEET

is to provide a one-way fluid-based check valve to prevent gases from being delivered to the cavity of a patient 48. As will be discussed in greater detail below, gases are allowed to travel downwardly through the second tube 84, but are not allowed to travel from the upper portion 82 of the second chamber 80 through tube 84. As discussed above, the second chamber 80 includes a second column of fluid 88 which is 2 cm. high in the preferred embodiment of the invention. The second column of fluid 88 acts to prevent gas present in the upper portion 82 of the second chamber 80 from entering the first end 86 of the second tube 84 in the event that the pressure in the upper portion 82 of the second chamber 80 is greater than the pressure in the patient's cavity. The pressure in the upper portion 82 of the second chamber may be greater than the pressure in the patient's cavity when the system 10 is disconnected from a high-vacuum source. In this event, the pressure and the upper portion 82 of the second chamber 80 will rise to atmospheric pressure. If fluid is not present in the second chamber 80, this atmospheric pressure can be transmitted too the patient's cavity causing the patient's lung to collapse. This is prevented by the presence of a second column of fluid 88 and the second chamber 80. When the pressure in the upper portion 82 of the chamber 80 is greater than the pressure in a patient's cavity, each exhalation of the patient will cause the fluid in the second chamber 80 to be drawn up into the second tube 84 temporarily. The fluid that is drawn up into the second tube 84 rises and falls with each patient inhalation and exhalation whenever the system 10 is disconnected from a high-vacuum source. This fluid in the second tube 84 prevents any gas present in the second chamber from entering into the patient's chest cavity.

One feature of the control module 14 is that the first tube 58 includes a mesh net 100 covering the first end 60 of the first tube 58. The purpose of the mesh net 100 is to cause air drawn through the first tube 58 into the first column 58 of fluid to be broken up into very fine bubbles. This act of breaking the air into fine bubbles reduces turbulence in the first column 56 of fluid. This is important because it prevents splashing of fluid 56 in the first chamber into the second

chamber 80 through the second path 82.

As discussed above, the lid 66 and the upper portion 102 of the control module between the first and second chambers 54, 80 forms the second path 82. In the preferred embodiment of the invention, the lid 66 and the upper portion 102 of the control module 14 form a gap with one another that creates the second path 82. The entrance to the second path 82 from the first chamber 54 in the preferred embodiment is no greater than 0.06 inches. The purpose of providing a very small entrance to the second path 82 from the first chamber 54 is to reduce the possibility of fluid 56 in the first chamber 54 from entering the second chamber 80. In the preferred embodiment, the second path 82 is a narrow torturous path. As illustrated in FIG. 6, the path 82 is a "U"-shaped path formed by "U"-shaped portion 104 in the upper portion 102 of the control module 14 which is parallel to a "U"-shaped portion 106 in lid 66.

As also illustrated in FIG. 6, the second end 88 of the second tube 84 is attached to a vacuum-interface port 80. A float valve 108 is located inside the port 80. The float valve 108 includes an inverted rubber cup 110 which is centered over the upper end 88 of the second tube 84. As fluid in the second tube 84 reaches the inverted cup 110, the cup rises until a flexible gasket 112 located between the upper portion of the cup 110 and the vacuum-interface port 84 causes the float valve 108 to close.

One important feature of the preferred embodiment of the invention is that the lid 66 includes at least one bleed orifice 114. In the preferred embodiment of the invention, a bleed orifice 114 is located adjacent to the first path 78 on the lid 66. The purpose of the bleed orifice 114 is to transform the high-source vacuum into an intermediate level vacuum which can be further reduced to a low vacuum by the first chamber 54 of the control module 14. By allowing small amounts of air to enter into the first and second chambers 54, 80 through the bleed orifice 114, the vacuum from the high-vacuum source is partially reduced.

The high vacuum from the high-vacuum source is also partially reduced through the use of an in-line orifice 116 located in the high-vacuum cap 74. The relatively small in-line orifice 116 causes the high vacuum from the high-vacuum source to be reduced to a lower vacuum since the bleed orifice 114 pulls air into the upper portions of the first and second chambers as a high vacuum is applied to the in-line orifice 116. Therefore, the in-line orifice 116 and the bleed orifice 114 act in conjunction to produce an intermediate level vacuum which is then reduced to a low vacuum as discussed above.

10 In the preferred embodiment of the invention, the first column of fluid 56 in the first chamber 54 is formed using no greater than \_\_\_\_\_ cc of fluid to provide 20 cm. H<sub>2</sub>O vacuum in the first and second chambers 54, 80 when the high-vacuum source provides up to 14.7 psi vacuum to the first path 78. This is a relatively small amount of fluid compared to other systems used in the past. This small amount of fluid is able to provide a reduction in vacuum due to the use of the bleed orifice 114 and the in-line orifice 116 to step down the vacuum from the high-vacuum source to an intermediate level vacuum.

20 Refer again to FIG. 1, as can be seen in this figure in the preferred embodiment of the invention, a vacuum-sensing valve 118 is provided in series between the low-vacuum source 120 of the control module 14 and the inside 122 of the liner 22. The valve is designed to open the inside of the liner to atmospheric pressure when the vacuum inside 122 the liner 22 exceeds a pre-determined value. In the preferred embodiment of the invention, the pre-determined value is 40 cm. H<sub>2</sub>O. This prevents undesirably high vacuums from being applied to the patient's chest cavity. The valve 118 will now be described in greater detail. Refer now to FIG. 8, which is a cut-away view of the vacuum-sensing valve 118. The valve includes a valve body 124, a seat 126 and an elastomeric umbrella 128.

30 As can be seen in FIG. 8, the seat 126 of the vacuum-sensing valve 118 includes a plurality of openings 130 to allow atmospheric

air to enter the valve body 124 when the vacuum within the valve body exceeds a pre-determined level. When the vacuum exceeds this pre-determined level, the edges 132 of the elastomeric umbrella 128 will be drawn toward the center of the valve body 124 and away from the valve seat 126. When the edges 132 of the elastomeric umbrella 128 are in their normal position, the edges 132 are biased against the openings 130. However, when the vacuum exceeds the pre-determined level, as discussed above, the edges will withdraw into the valve body 124 to allow atmospheric air into the valve body. This prevents undesirably high vacuums which may be present inside the liner 122 to be applied to the chest cavity of a patient.

Refer now to FIG. 1. One important feature of the invention is that the system 10 includes a drainage means 134 for providing fluid communication between the inside of the liner 122 and the chest cavity of the patient 48. In the preferred embodiment of the invention, the drainage means 134 includes a drainage tube 50 which is connected to a patient port 136 and the cover 24 of the system 10. The patient port 136 has a porous filter 138 attached to collect large particle-size debris which may be drawn into the system from the patient's chest cavity. This filter prevents this debris from being mixed with fluid that is collected in the liner 22 for later re-infusion back into the patient. In the preferred embodiment of the invention, the filter has a pore size of between 120 and 130 microns. The filter is located inside the liner 22 immediately under the patient port 136.

In the preferred embodiment of the invention, the cover 24 also includes an interface port 140 to allow removal of fluids from the liner 22 for further processing or re-infusion back into the patient without removing the liner from the cannister. When the interface port 140 is not in use, the port is covered with a cap 142. In the preferred embodiment of the invention, a sterile straw 144 is inserted into the liner 22 to withdraw fluids from the bottom of the liner. The straw is illustrated in FIG. 10 in its pouch.

The straw 144 has first and second ends 146, 148. The first

end of the straw can be inserted through the interface port 140 down into the bottom of the liner 22. The second end 148 of the straw 144 is attached to an elbow 150. The elbow includes first and second ends 152, 154. The first end of the elbow includes a skirt 156 which is designed to fit snugly around the outside diameter of the interface port 140 to firmly secure the straw onto the interface port 140. Accordingly, the skirt 156 consists of a ring which can be concentrically placed about the interface port 140. The second end 154 of the elbow 150 has a tapered port for connection to tubing of various inside diameters. This port is normally attached to such tubing to allow fluid within the liner to be drawn into the tubing either for re-infusion back into the patient or for further processing. For example, in some instances, it may be desirable to sent the fluid through a cell washer to remove the red cells from the fluid and discard any other debris that may be present in the fluid. The red cells may then be used by the patient.

Thus, it is important for the straw 144 to be maintained in a sterile condition prior to insertion into the liner 22. It is also important that the medical personnel be able to insert the straw 144 into the liner 22 without compromising its sterility. Therefore, one feature of this invention is to provide a sterile system in which the straw is maintained in a sterile, thin-walled flexible sleeve 158 prior to insertion into the liner 22. As can be seen in FIG. 10, the sleeve completely covers the straw. The sleeve has first and second ends 160 and 162. In the preferred embodiment, the ends are simply folded inward towards the sleeve and taped shut. In one embodiment of the invention, medical personnel can open the first end 160 of the sleeve 158 to expose the first end 146 of the straw 144. The first end 160 of the sleeve 158 can be pushed back toward the elbow to allow the first end 146 of the straw 144 to be inserted into the liner 22 while the second end 148 of the straw remains covered by the sleeve 158. After the straw has been inserted, the sleeve can be completely removed to allow the second end 154 of the elbow 150 to be attached to a tube as discussed above. In another embodiment of the invention the first end 160 of the sleeve 158 is opened simply by

forcefully puncturing the sleeve with the first end **146** of the straw **144**.

In order to insure that the straw **144** is transported in a sterile condition, the entire sleeve **158** is enclosed in an outer peelable outer pouch **164**. The outer pouch can be opened by a "non-sterile" medical personnel to present the sterile sleeve **158** and straw **144** to a "sterile" nurse.

Refer now to **FIG. 11** which is a perspective view of a tray **166** used to store and transport the control module **14**. The tray **166** includes a storage means **168** for maintaining the control module **14** in a horizontal position within the tray as the module is being transported. The tray **166** also includes a holding means **170** for maintaining the control module **14** in a vertical position in the tray **168** to allow the control module **14** to be partially filled with sterile fluid. This is illustrated in **FIG. 12**. In the preferred embodiment of the invention, the holding means includes a pair of indentions **172** which form a slot **174** for maintaining the control module **14** in a vertical position. In the preferred embodiment, the storage means **168** is a pre-formed plastic container **176** having a top opening **178** that is sealed with a lid **180** which can be peeled away from the top opening to expose the inside of the container **176**. In the preferred embodiment, the pre-formed container **176** includes a bottom and side walls which generally conform to the overall outer shape of the control module **14** when the control module **14** is in a horizontal position. Thus, the control module **14** can be snugly placed inside the container **176** to be transported.

The tray **166** described herein has several advantages. First, the use of the tray to maintain the control module in an upright position as the module is being filled acts as a sterile field around the control module since the inside of the tray is sterile prior to peeling back the lid **180** from the top **178** of the tray. Second, the tray **166** acts as a fluid collection means to collect any spills which may occur as the module is being filled. This is of great value to operating room

personnel.



**I claim:**

1    **1.** A system for collection and reinfusion of fluids from a patient,  
2    comprising:

3           a rigid cannister having walls forming a cavity, said cannister  
4           also having a top opening:

5           a hollow liner for insertion into said cavity of said cannister,  
6           said liner to receive fluids from a patient, said liner having

7                   a cover for attaching said liner to said top of said cannis-  
8                   ter,

9                   a flexible body having upper and lower portions, said  
10                   upper portion being attached to said cover,

11                   a bottom attached to said lower portion of said body,

12                           said flexible body and said bottom being shaped so  
13                           as to generally conform to said walls of said can-  
14                           nister, said flexible body and said bottom being  
15                           located within said cavity of said canister when  
16                           said cover is attached to said top of said cannister;

17                   vacuum means for continuously providing a relatively  
18                   high vacuum to said cavity of said cannister and a rela-  
19                   tively low vacuum inside said liner when said liner is  
20                   located in said cavity to cause said liner expand against  
21                   said walls of said cannister; and

22                   drainage means for providing fluid communication  
23                   between said inside of said liner and said patient.

1    **2.** A system as recited in claim 1 wherein said vacuum means fur-  
2    ther includes

3 a low vacuum source; and

4 a vacuum sensing valve in series between said low vacuum  
5 source and said inside of said liner, said valve opening to atmo-  
6 sphere when said vacuum inside said liner exceeds a predeter-  
7 mined value.

1 3. A system as recited in claim 2 wherein said valve opens to  
2 atmosphere when said vacuums inside said liner exceeds 40 cm H<sub>2</sub>O  
3 vacuum.

1 4. A system as recited claim 2 wherein said valve is an elastomer  
2 umbrella valve.

1 5. A system as recited in Claim 2 wherein said low vacuum source  
2 further includes:

3 a control module for transforming a variable high vacuum into a  
4 constant low vacuum and for providing a one-way check valve  
5 to prohibit return of air when draining fluids and air from a  
6 patient, said control module having

7 a first suction control chamber for transforming said vari-  
8 able high vacuum into a constant low vacuum, said first  
9 chamber containing a first column of fluid at a first pre-  
10 determined level;

11 a second water seal chamber for containing a second  
12 column of fluid at a second predetermined level, said  
13 second level being less than said first level;

14 a lid covering an upper surface of both of said first and  
15 second chambers, said lid providing a first path between  
16 said high vacuum source and said second chamber, said  
17 lid also providing a pathway connecting said first and  
18 second chambers above said fluid levels in said first and  
19 second chambers thereby equalizing the pressure in said  
20 first and second chambers,

21 a first tube within said first chamber, said first tube hav-  
22 ing first and second ends, said first end being immersed  
23 in said fluid and said second end extending above said  
24 first chamber through said lid and being open to atmo-  
25 spheric pressure, whereby when said high vacuum  
26 source is applied to said first chamber through said  
27 pathway, said first tube supplies atmospheric air to said  
28 high vacuum source through said first column of fluid via  
29 bubbles thereby creating a residual pressure in said first  
30 chamber which remains constant and dependent on the  
31 height of said column of fluid in said first chamber; and

32 a second tube within said second chamber, said second  
33 tube having first and second ends, said first end being  
34 immersed in said fluid in said second chamber and said  
35 second end in communication with the pleural cavity of  
36 the patient, said vacuum in said second chamber being  
37 normally lower than the vacuum in the patient's pleural  
38 cavity thereby causing air in the cavity to be pulled  
39 through said second end of said second tube through  
40 said second column of fluid toward said high vacuum  
41 source, when said vacuum in said cavity is greater than  
42 vacuum in the second chamber, fluid in said second  
43 chamber is pulled into said second tube to prevent air in  
44 said second chamber from returning to said pleural cav-  
45 ity, said second tube having a valve located at said sec-  
46 ond end which closes when fluid rises to said second end  
47 of said tube.

1 6. A system as recited in claim wherein said drainage means fur-  
2 ther includes:

3 a porous filter having a pore size between 120 and 130  
4 microns, said filter being located inside said hollow liner under  
5 said cover to filter gross debris in fluids collected from the  
6 patient.

**SUBSTITUTE SHEET**

1 7. A system as recited in claim 1 where said cover further includes  
2 an interface port to allow removal of fluid from said hollow liner to  
3 allow further processing of the fluids or direct reinfusion of the fluids  
4 back into the patient without removing said liner from said cannister.

1 8. A system as recited in claim 7 further comprising:

2 a sterile straw for insertion through said interface port into said  
3 hollow liner to siphon fluid for further processing of the fluids  
4 or direct reinfusion of the fluids back into the patient without  
5 removing said liner from said cannister.

1 9. A system as recited in claim 8, further including an elbow having  
2 first and second ends, said first end attached to one end of said  
3 straw, said second end of said elbow having a tapered port for con-  
4 nection to tubing of various inside diameters.

1 10. A system as recited in claim 9, wherein said first end of said  
2 elbow further includes a skirt for mounting on said interface port on  
3 said cover to provide a firm connection between said elbow and said  
4 cover.

1/9

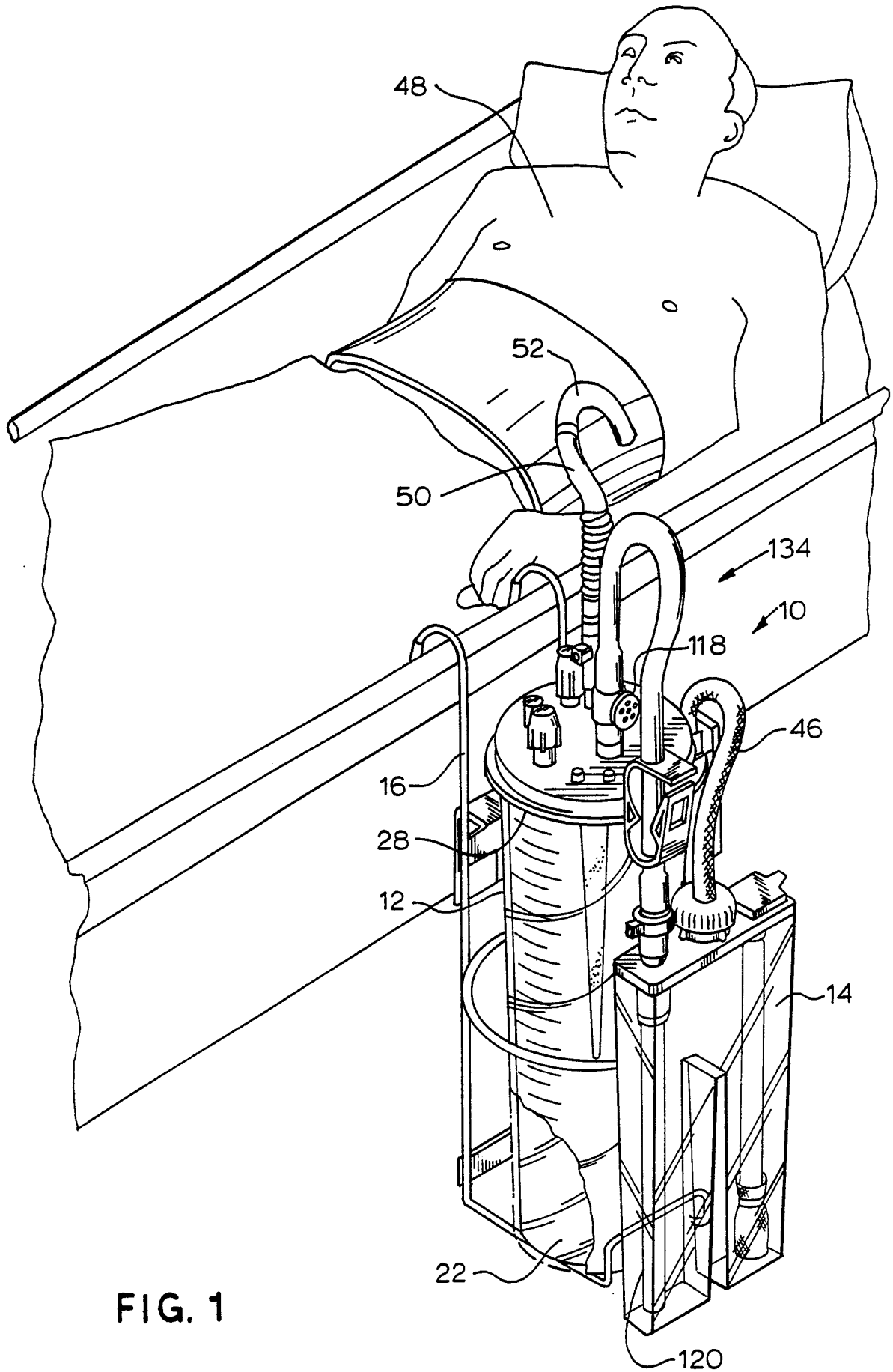

FIG. 1

2/9

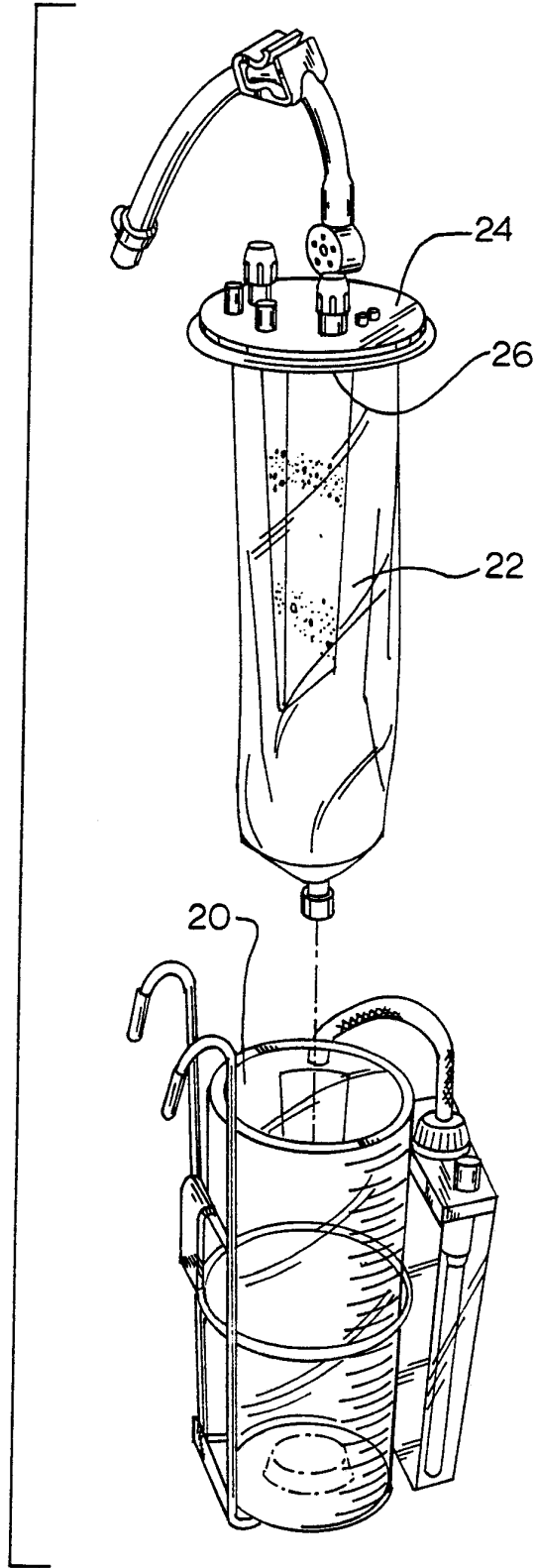

FIG. 2

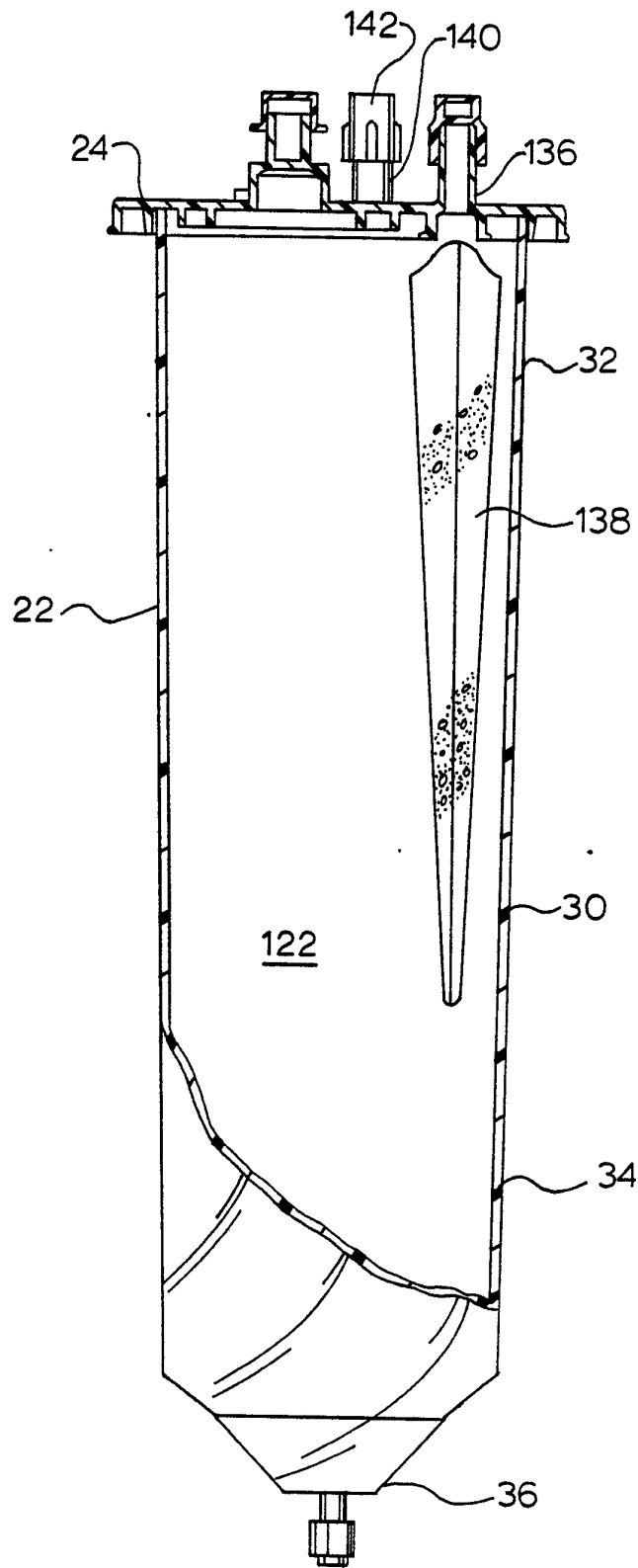

FIG. 3

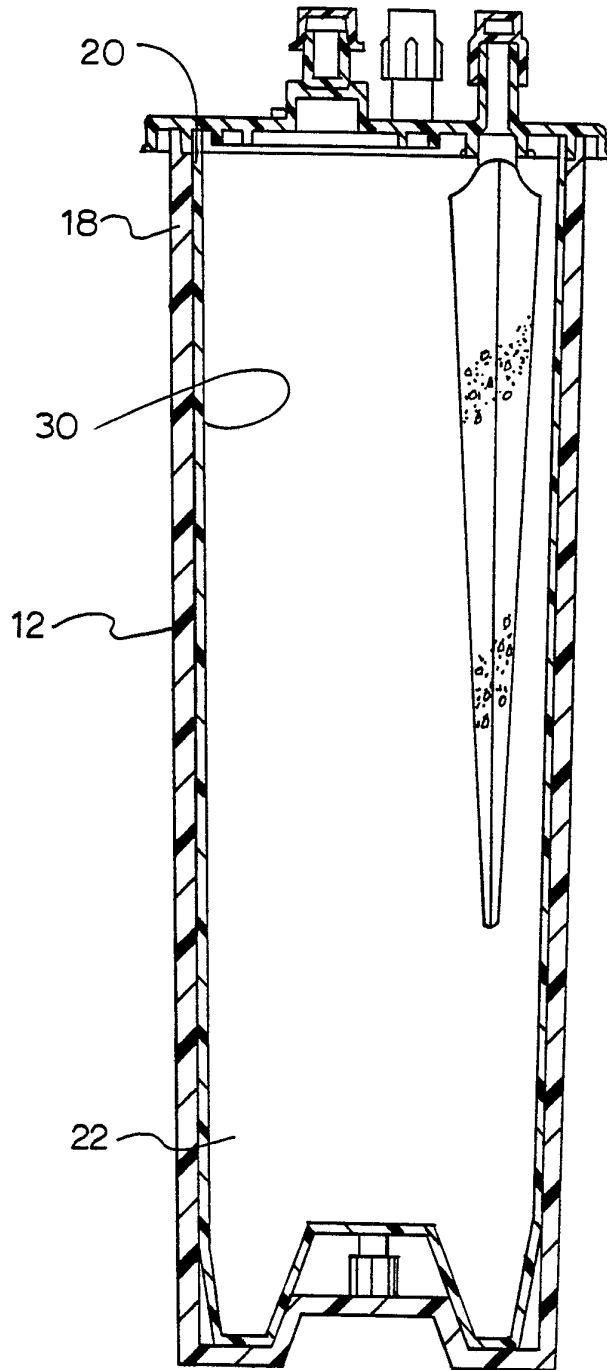

FIG. 4



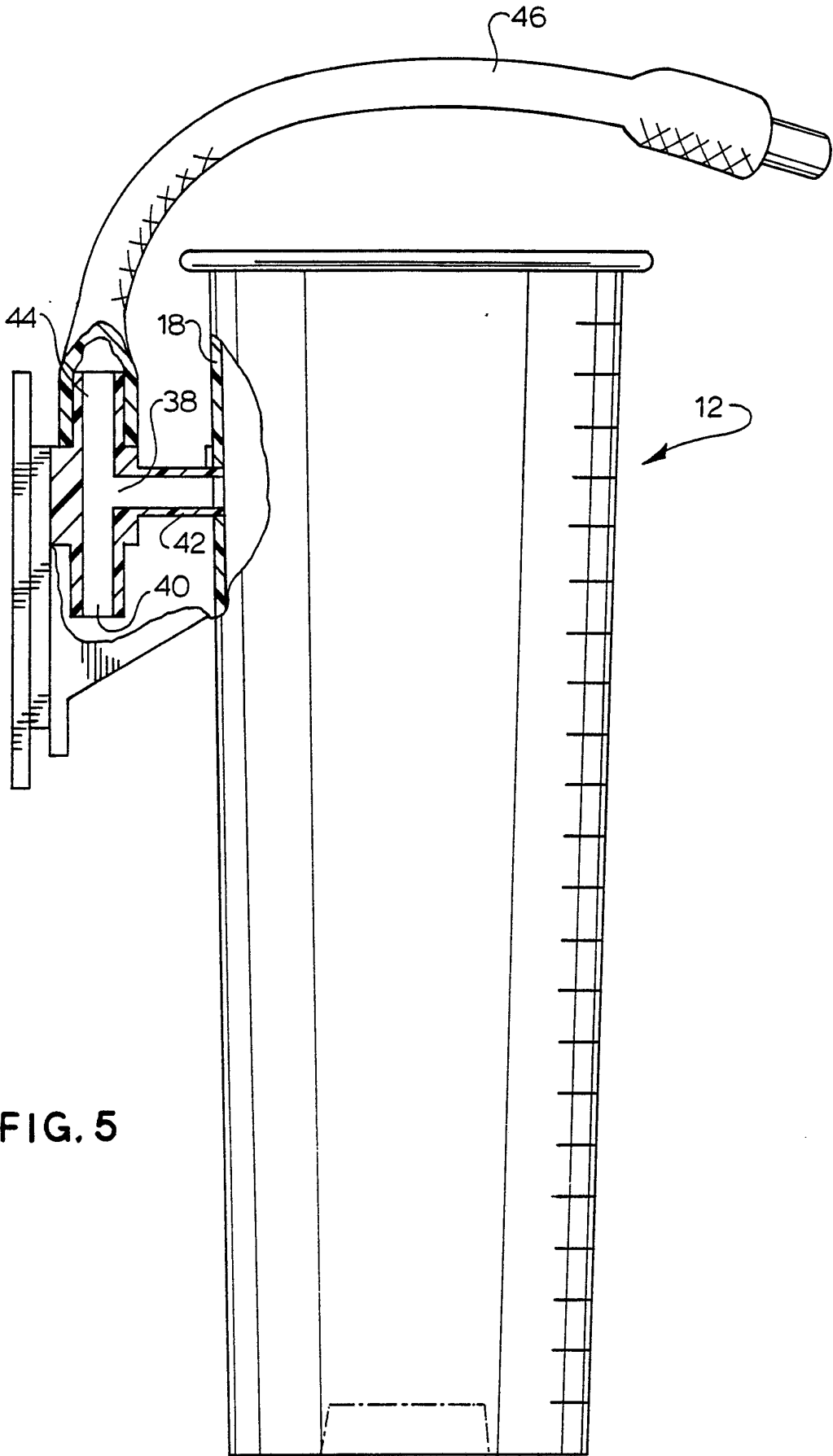

FIG. 5

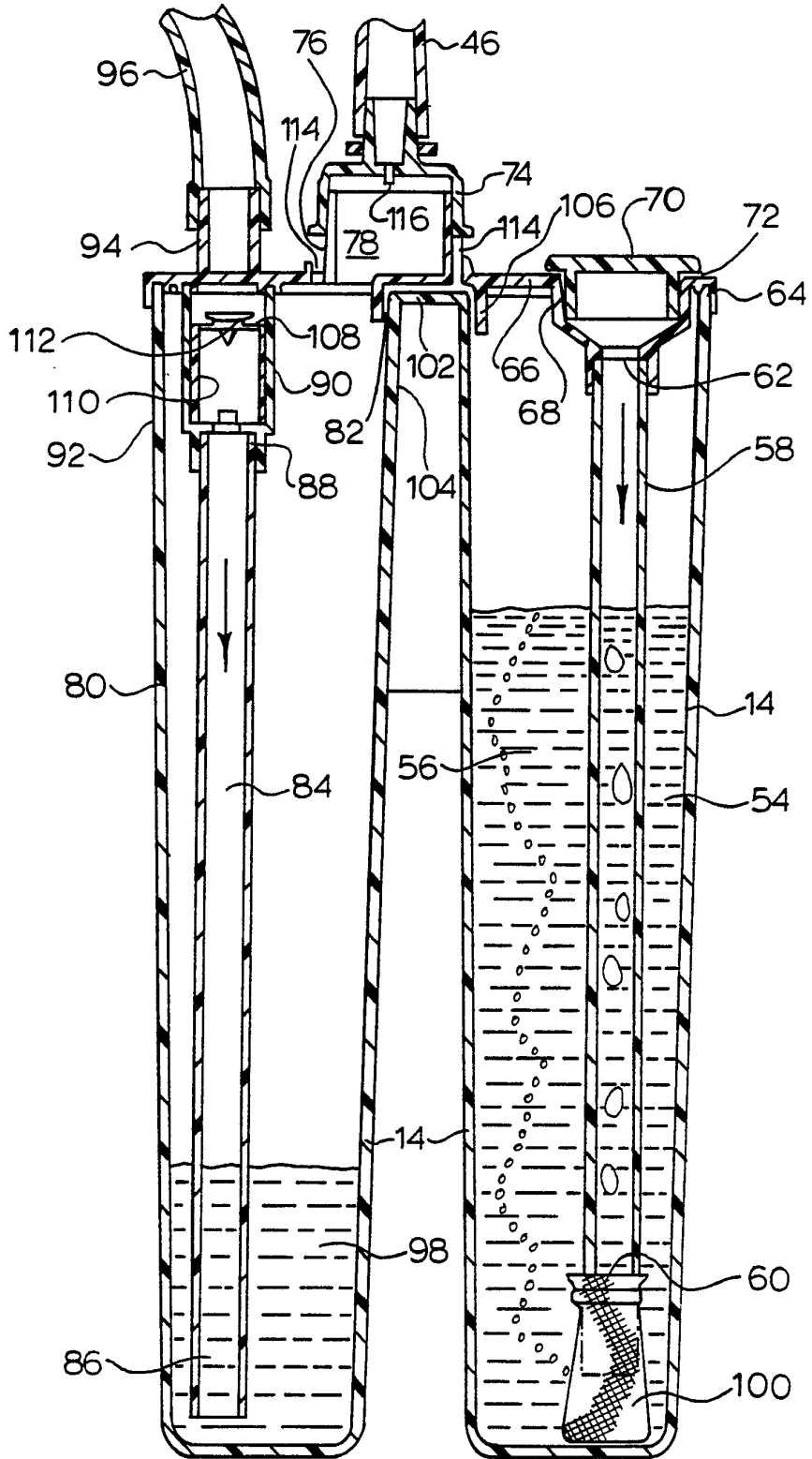

FIG. 6

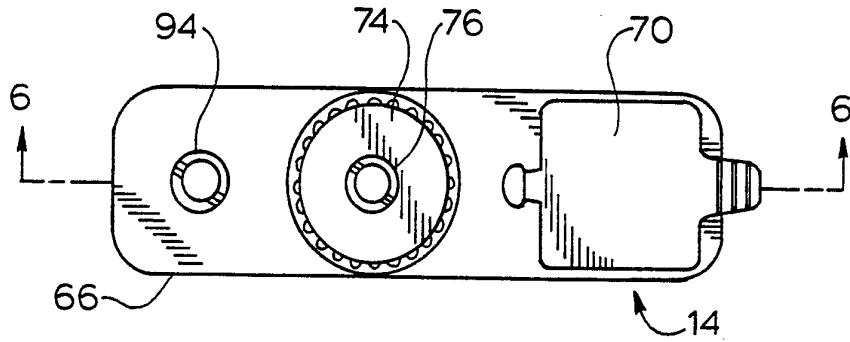

FIG. 7

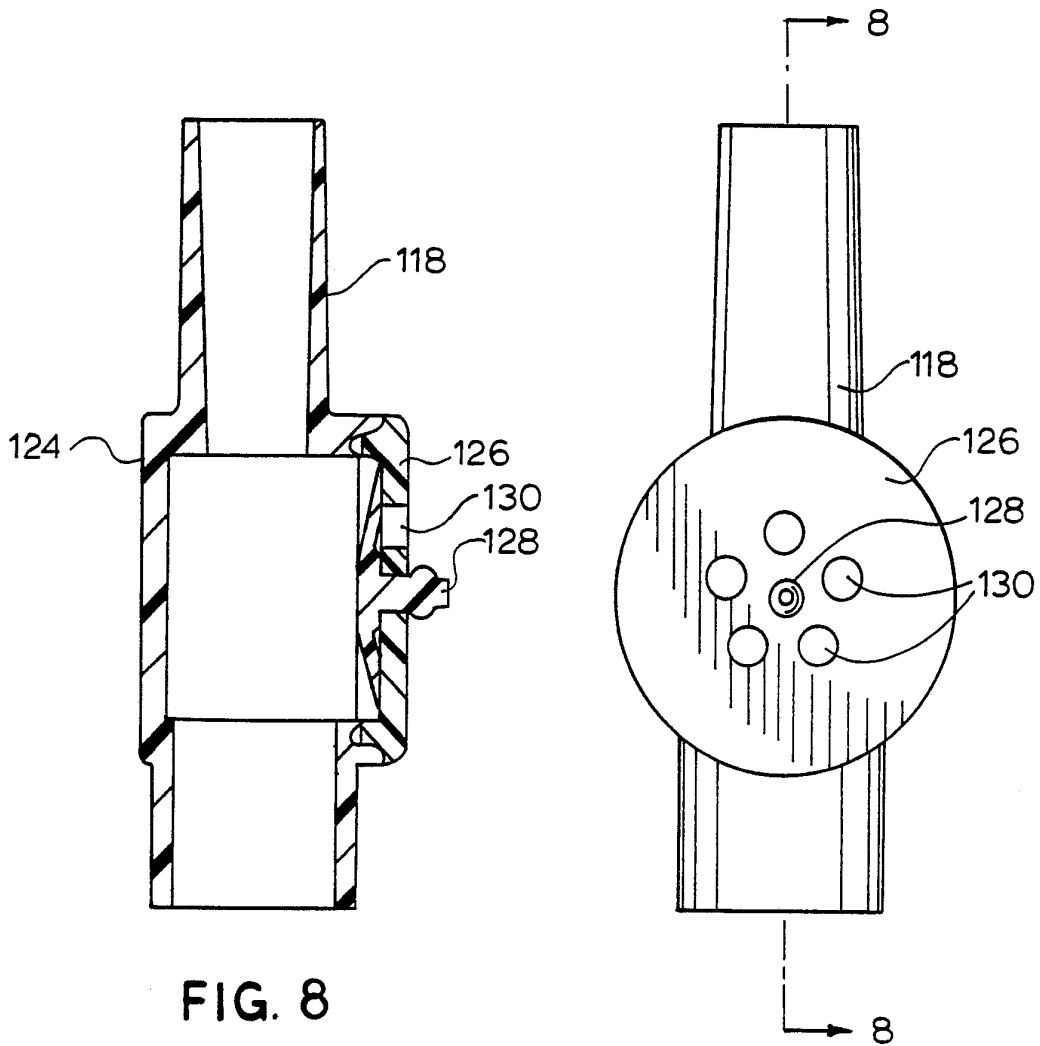

FIG. 8

FIG. 9

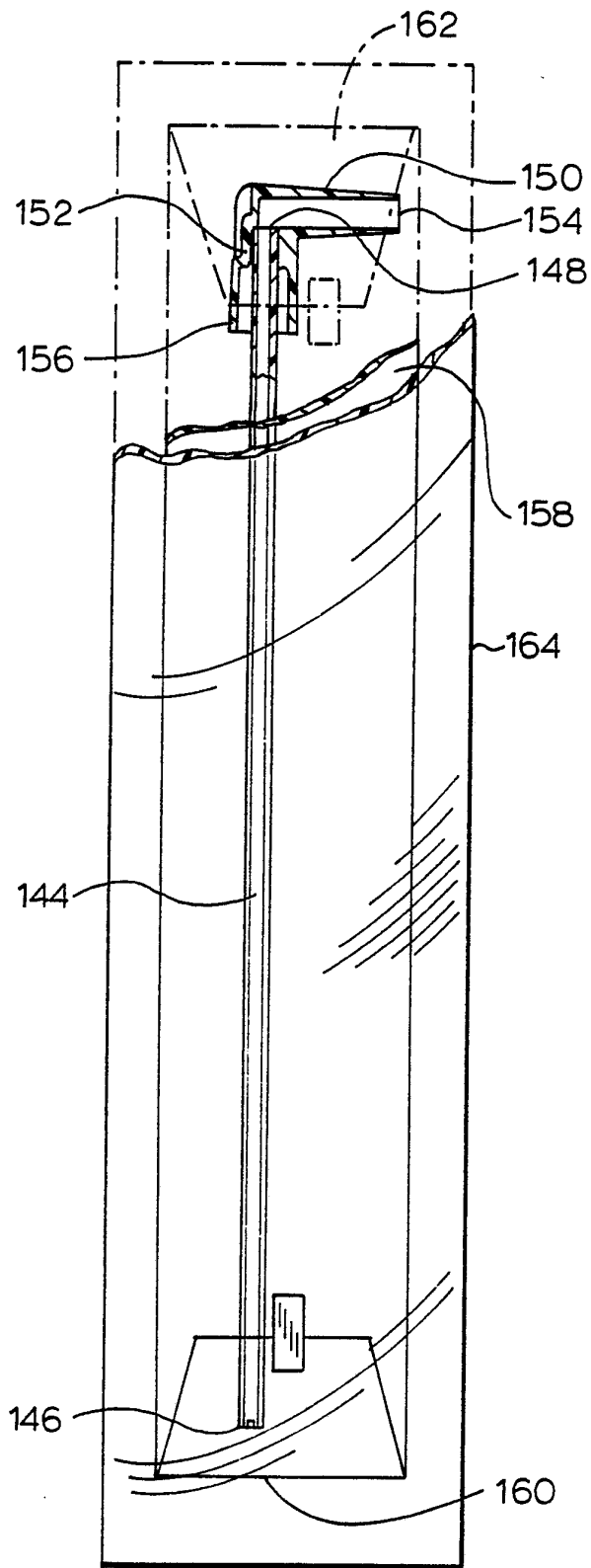

FIG. 10

9/9

FIG. 11

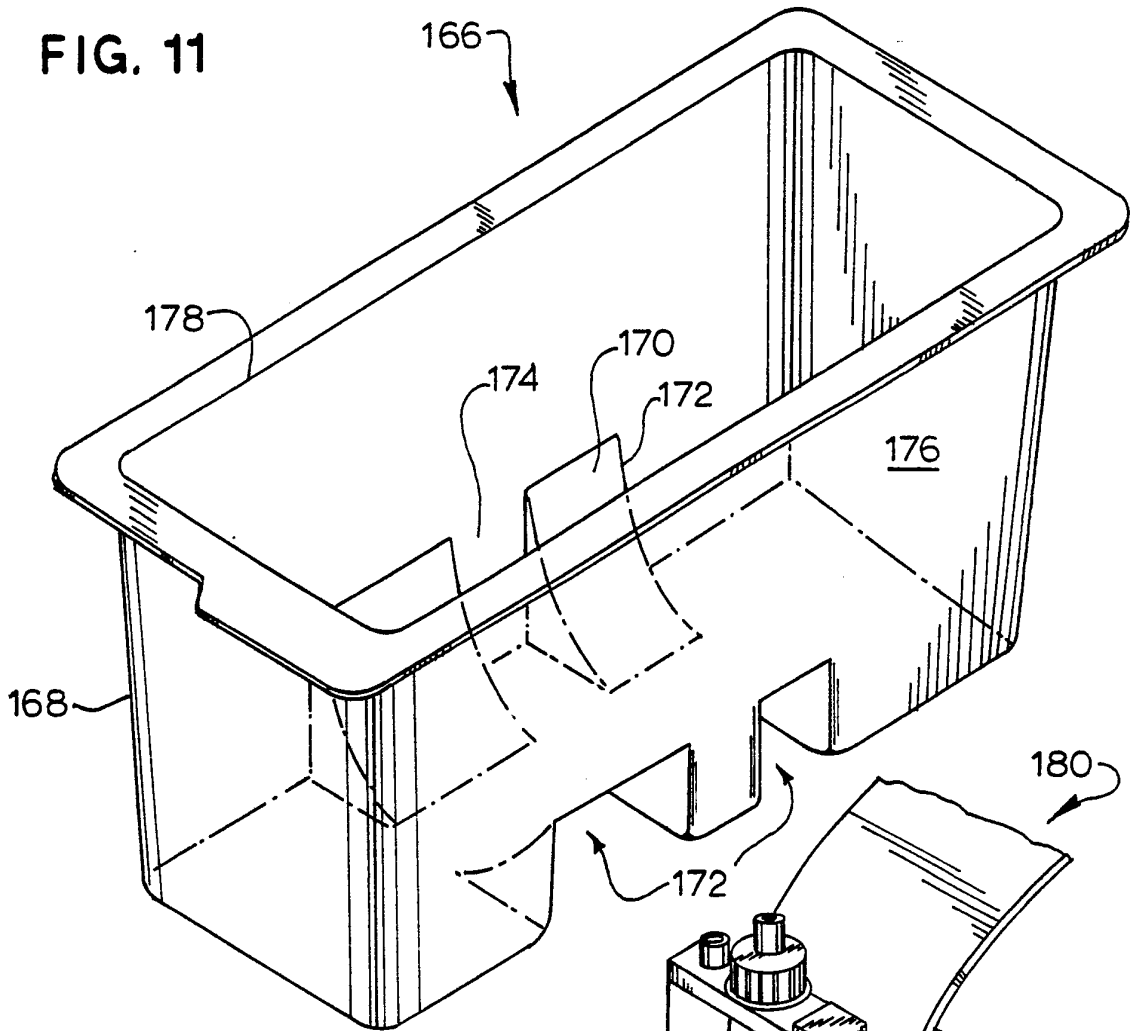

FIG. 12

