

(19) World Intellectual Property Organization
International Bureau



(43) International Publication Date
17 April 2008 (17.04.2008)

PCT

(10) International Publication Number
WO 2008/045311 A2

(51) International Patent Classification:
G02B 6/00 (2006.01) *G02B 6/122* (2006.01)

(74) Agent: **ABUMERI, Mark, M.**; Knobbe Martens Olson & Bear, Llp, 2040 Main Street, Fourteenth Floor, Irvine, CA 92614 (US).

(21) International Application Number:
PCT/US2007/021376

(81) Designated States (unless otherwise indicated, for every kind of national protection available): AE, AG, AL, AM, AT, AU, AZ, BA, BB, BG, BH, BR, BW, BY, BZ, CA, CH, CN, CO, CR, CU, CZ, DE, DK, DM, DO, DZ, EC, EE, EG, ES, FI, GB, GD, GE, GH, GM, GT, HN, HR, HU, ID, IL, IN, IS, JP, KE, KG, KM, KN, KP, KR, KZ, LA, LC, LK, LR, LS, LT, LU, LY, MA, MD, ME, MG, MK, MN, MW, MX, MY, MZ, NA, NG, NI, NO, NZ, OM, PG, PH, PL, PT, RO, RS, RU, SC, SD, SE, SG, SK, SL, SM, SV, SY, TJ, TM, TN, TR, TT, TZ, UA, UG, US, UZ, VC, VN, ZA, ZM, ZW.

(22) International Filing Date: 5 October 2007 (05.10.2007)

(25) Filing Language: English

(26) Publication Language: English

(30) Priority Data:
60/850,189 6 October 2006 (06.10.2006) US

(71) Applicant (for all designated States except US): **QUALCOMM MEMS TECHNOLOGIES, INC.** [US/US]; 5775 Morehouse Drive, San Diego, CA 92121 (US).

(84) Designated States (unless otherwise indicated, for every kind of regional protection available): ARIPO (BW, GH, GM, KE, LS, MW, MZ, NA, SD, SL, SZ, TZ, UG, ZM, ZW), Eurasian (AM, AZ, BY, KG, KZ, MD, RU, TJ, TM), European (AT, BE, BG, CH, CY, CZ, DE, DK, EE, ES, FI, FR, GB, GR, HU, IE, IS, IT, LT, LU, LV, MC, MT, NL, PL, PT, RO, SE, SI, SK, TR), OAPI (BF, BJ, CF, CG, CI, CM, GA, GN, GQ, GW, ML, MR, NE, SN, TD, TG).

(72) Inventors; and

(75) Inventors/Applicants (for US only): **BITA, Ion** [RO/US]; 65 Rio Robles East, Apt. 1204, San Jose, CA 95134 (US). **MIENKO, Marek** [US/US]; 185 Estancia Drive, #316, San Jose, CA 95134 (US). **XU, Gang** [US/US]; 10092 Amador Oak Court, Cupertino, CA 95014 (US). **GRUHLKE, Russell, Wayne** [US/US]; 1820 View Drive, Milpitas, CA 95035 (US).

Published:
— without international search report and to be republished upon receipt of that report

(54) Title: ILLUMINATION DEVICE WITH BUILT-IN LIGHT COUPLER

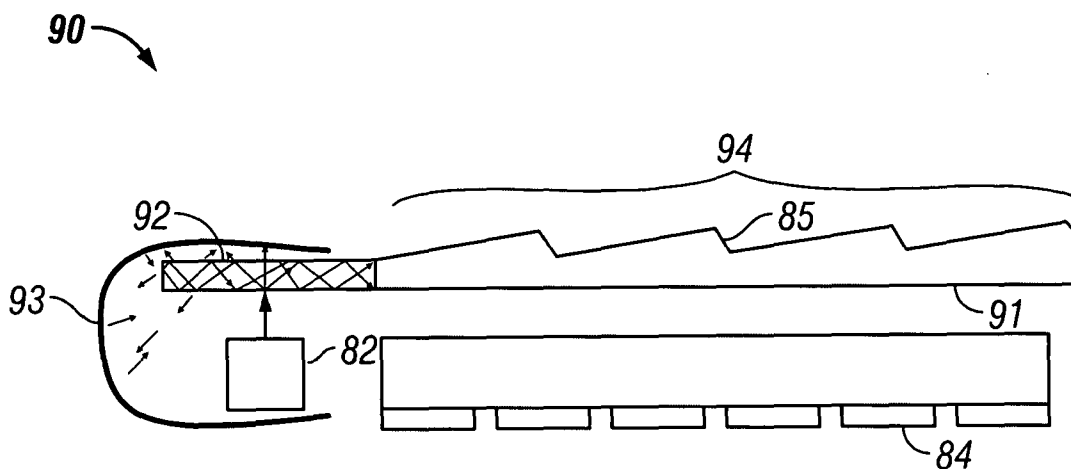

(57) Abstract: The invention comprises devices and methods for coupling a light source to a display illumination device. In one embodiment, an illumination device includes a light guide comprising a front surface, a back surface, a light coupling section configured to receive optical energy from a light source in to the light guide through said front surface or said back surface at an angle about normal to the optical energy receiving surface, and further configured to direct light through said light guide, and a light turning section configured to redirect out of the light guide at least a portion of the light received from said light coupling section, said redirected light at an angle about normal to the optical energy receiving surface.

WO 2008/045311 A2

ILLUMINATION DEVICE WITH BUILT-IN LIGHT COUPLER

Priority Application

[0001] This application claims priority to U.S. Provisional Patent Application No. 60/850,189, entitled "Illumination Device With Built-in Light Coupler," filed October 6, 2006, which is incorporated by reference herein in its entirety.

Background

Field of the Invention

[0002] The field of the invention relates to microelectromechanical systems (MEMS).

Description of the Related Art

[0003] Microelectromechanical systems (MEMS) include micro mechanical elements, actuators, and electronics. Micromechanical elements may be created using deposition, etching, and/or other micromachining processes that etch away parts of substrates and/or deposited material layers or that add layers to form electrical and electromechanical devices. One type of MEMS device is called an interferometric modulator. As used herein, the term interferometric modulator or interferometric light modulator refers to a device that selectively absorbs and/or reflects light using the principles of optical interference. In certain embodiments, an interferometric modulator may comprise a pair of conductive plates, one or both of which may be transparent and/or reflective in whole or part and capable of relative motion upon application of an appropriate electrical signal. In a particular embodiment, one plate may comprise a stationary layer deposited on a substrate and the other plate may comprise a metallic membrane separated from the stationary layer by an air gap. As described herein in more detail, the position of one plate in relation to another can change the optical interference of light incident on the interferometric modulator. Such devices have a wide range of applications, and it would be beneficial in the art to utilize and/or modify the characteristics of these types of devices so that their features can be exploited in improving existing products and creating new products that have not yet been developed.

Summary of Certain Embodiments

[0004] The system, method, and devices of the invention each have several aspects, no single one of which is solely responsible for its desirable attributes. Without limiting the scope of this invention, its more prominent features will now be discussed briefly. After considering this discussion, and particularly after reading the section entitled “Detailed Description of Certain Embodiments” one will understand how the features of this invention provide advantages over other illumination and/or devices.

[0005] One embodiment includes an illumination device comprising a light guide comprising a front surface, a back surface, a light coupling section configured to receive optical energy from a light source in to the light guide through said front surface or said back surface at an angle about normal to the optical energy receiving surface, and further configured to direct light through said light guide, and a light turning section configured to redirect out of the light guide at least a portion of the light received from said light coupling section, said redirected light at an angle about normal to the optical energy receiving surface. The illumination device can further comprise a light source disposed with respect to said light coupling portion to inject light into said light coupling portion, and the light source can be disposed adjacent to said optical energy receiving surface of the light coupling section such that at least a portion of the provided light is incident on said optical energy receiving surface at an angle about normal to said optical energy receiving surface.

[0006] Another embodiment includes an illumination device comprising means for guiding light, said guiding light means having a front and a back surface, said light guiding means comprising means for coupling optical energy that is received from a light source in to the light guiding means through said front surface or said back surface at an angle about normal to the optical energy receiving surface, and further configured to direct light through said light guiding means, and means for turning light to redirect out of the light guiding means at least a portion of the light received from said coupling means, said redirected light at an angle about normal to the optical energy receiving surface.

[0007] Another embodiment includes a method of manufacturing an illumination device, said method comprising forming a substantially planar light guide having a front surface

and a back surface that define the front surfaces and back surfaces of a light coupling section and a light turning section disposed adjacently in said light guide, said light coupling section configured to receive optical energy from a light source through said front or back surface at an angle substantially normal to the optical energy receiving front or back surface and propagate the light through the light guide to said light turning section, and wherein said light turning section is configured to direct light from light coupling section out of said light guide.

[0008] Another embodiment includes a display device fabricated by the method of described in the preceding paragraph.

[0009] Another embodiment includes a method of illuminating an array of interferometric modulators positioned behind a light guide so that the light guide is between light modulating surfaces of said array and ambient light, the method comprising receiving optical energy on a back surface of a substantially planar light guide, wherein at least a portion of the optical energy is received from a direction about normal to said back surface, coupling the received optical energy into the light guide such that at least a portion of the received optical energy propagates through said light guide, and redirecting light propagating in the light guide towards an array of interferometric modulators positioned parallel and adjacent to said back surface. The method can further include providing optical energy on a portion of said back surface, wherein at least a portion of said optical energy is provided in a direction about normal to said back surface.

[0010] Another embodiment includes a method of manufacturing a master mold of an illumination device comprising providing a crystalline substrate, forming a first mask on the substrate, the first mask having openings about every $10^4 - 10^6$ nm, performing an anisotropic wet etch of said substrate through said first mask, forming a second mask on the substrate, the second mask having openings about every $10^2 - 10^3$ nm, performing an anisotropic dry etch of said substrate through said second mask, and removing the first and second masks.

[0011] Another embodiment includes an illumination device comprising a light guide comprising a front surface, a back surface, a light coupling section comprising light emitting material, said coupling section configured to receive optical energy from a light source in to the light guide through said front surface or said back surface at an angle about normal to the optical energy receiving surface, and further configured to direct light through said light guide, and a

light turning section configured to redirect out of the light guide at least a portion of the light received from said light coupling section, said redirected light at an angle about normal to the optical energy receiving surface.

Brief Description of the Drawings

[0012] Figure 1 is an isometric view depicting a portion of one embodiment of an interferometric modulator display in which a movable reflective layer of a first interferometric modulator is in a relaxed position and a movable reflective layer of a second interferometric modulator is in an actuated position.

[0013] Figure 2 is a system block diagram illustrating one embodiment of an electronic device incorporating a 3x3 interferometric modulator display.

[0014] Figure 3 is a diagram of movable mirror position versus applied voltage for one exemplary embodiment of an interferometric modulator of Figure 1.

[0015] Figure 4 is an illustration of a set of row and column voltages that may be used to drive an interferometric modulator display.

[0016] Figure 5A illustrates one exemplary frame of display data in the 3x3 interferometric modulator display of Figure 2.

[0017] Figure 5B illustrates one exemplary timing diagram for row and column signals that may be used to write the frame of Figure 5A.

[0018] FIGS. 6A and 6B are system block diagrams illustrating an embodiment of a visual display device comprising a plurality of interferometric modulators.

[0019] Figure 7A is a cross section of the device of Figure 1.

[0020] Figure 7B is a cross section of an alternative embodiment of an interferometric modulator.

[0021] Figure 7C is a cross section of another alternative embodiment of an interferometric modulator.

[0022] Figure 7D is a cross section of yet another alternative embodiment of an interferometric modulator.

[0023] Figure 7E is a cross section of an additional alternative embodiment of an interferometric modulator.

[0024] Figure 8 illustrates one embodiment of a front illumination device that can be used to illuminate a reflective interferometric modulator display.

[0025] Figure 9A is a schematic that illustrates an embodiment comprising an illumination device with both a surface coupling section and a light turning section.

[0026] Figure 9B is a schematic that illustrates another embodiment comprising an illumination device with both a surface coupling section and a light turning section.

[0027] Figure 10 is a schematic illustrating a transmissive surface diffraction grating in a light coupler section.

[0028] Figure 11 is a schematic illustrating a reflective surface diffraction grating in a light coupler section.

[0029] Figure 12 is a schematic illustrating a transmissive blazed surface diffraction grating in a light coupler section.

[0030] Figure 13 is a schematic illustrating a reflective blazed surface diffraction grating in a light coupler section.

[0031] Figure 14 is a schematic illustrating a transmissive volume diffraction grating in a light coupler section.

[0032] Figure 15 is a schematic illustrating a reflective volume diffraction grating in a light coupler section.

[0033] Figures 16A is a schematic illustrating a top view of an illumination device with both a surface coupling section and a light turning section.

[0034] Figures 16B is a schematic illustrating a side view of the illumination device with both a surface coupling section and a light turning section illustrated in Figure 16A.

[0035] Figure 17 illustrates a process of making the illumination device illustrated in Figure 16.

[0036] Figure 18 illustrates a process for recording a volume diffraction grating, such as the volume diffraction grating illustrated in Figure 14.

[0037] Figure 19A is a schematic illustrating a refractive coupler that can be included in a light coupler section.

[0038] Figure 19B is a schematic illustrating another view of the refractive coupler shown in Figure 19A.

[0039] Figure 20 is a schematic illustrating a light coupler section that uses light scattering or light absorption-reemission to couple light into the illumination section.

[0040] Figure 21 is a schematic illustrating another embodiment of a light coupler section that uses light emission produced via surface plasmon excitation to couple light into the illumination film.

[0041] Figure 22 is a schematic illustrating an embodiment of a transmission hologram volume diffraction grating used in the light coupler region.

[0042] Figure 23 is a schematic illustrating an embodiment of a reflection hologram volume diffraction grating used in the light coupler region.

Detailed Description of Certain Embodiments

[0043] The following detailed description is directed to certain specific embodiments of the invention. However, the invention can be embodied in a multitude of different ways. In this description, reference is made to the drawings wherein like parts are designated with like numerals throughout. Reference in this specification to "one aspect" or "an aspect" means that a particular feature, structure, or characteristic described in connection with the aspect is included in at least one aspect. The appearances of the phrase "in one aspect," "according to one aspect," or "in some aspects" in various places in the specification are not necessarily all referring to the same aspect, nor are separate or alternative aspects mutually exclusive of other aspects. Moreover, various features are described which may be exhibited by some aspects and not by others. Similarly, various requirements are described which may be requirements for some aspects but not other aspects.

[0044] As will be apparent from the following description, the embodiments may be implemented in any device that is configured to display an image, whether in motion (e.g., video) or stationary (e.g., still image), and whether textual or pictorial. More particularly, it is contemplated that the embodiments may be implemented in or associated with a variety of electronic devices such as, but not limited to, mobile telephones, wireless devices, personal data assistants (PDAs), hand-held or portable computers, GPS receivers/navigators, cameras, MP3 players, camcorders, game consoles, wrist watches, clocks, calculators, television monitors, flat panel displays, computer monitors, auto displays (e.g., odometer display, etc.), cockpit controls

and/or displays, display of camera views (e.g., display of a rear view camera in a vehicle), electronic photographs, electronic billboards or signs, projectors, architectural structures, packaging, and aesthetic structures (e.g., display of images on a piece of jewelry). MEMS devices of similar structure to those described herein can also be used in non-display applications such as in electronic switching devices.

[0045] An interferometric modulator display can employ a reflective pixel design. When sufficient ambient light is not available, an illumination system comprising a front illuminator that comprises a planar light guide disposed forward the reflective pixels can be used to provide light thereto. As market forces drive for a thinner and thinner display module thickness, each of the display components are subject to thickness optimization. In the area of the illumination apparatus, reducing its thickness may be accomplished by reducing the thickness of the light source that delivers light into the front light. While the planar light guide in front of the reflective pixels can be made thinner and thinner, there are practical limitations to how thin light sources can be made (e.g., LEDs have light emitting dies of 0.2-0.3 mm size, and the LED package further adds to this size). If edge injection is used to couple a light source to a planar light guide, reducing the thickness of the planar light guide beyond that of the light source leads to optical inefficiency. In particular, not all the emitted light can be delivered into the planar light guide due to the size mismatch between the emitting aperture of the light source and the input aperture of the light guide. Various embodiments disclosed herein allow a design and fabrication of a thin film illumination system that may overcome these and other problems by employing a light coupling region which receives light from a light source through a surface of the light guide rather than the edge of the light guide. Such embodiments provide both desired thin light guide and improved light injection efficiency.

[0046] Accordingly, various illustrative embodiments of coupling a light source through the surface of a thin illumination film are described herein. Some of these embodiments include using diffractive microstructures, solution, prismatic microstructures, and/or light emission-based elements to couple light from an external source (LED(s), light bar, etc.) to waveguide modes within the front light. In such embodiments, this light coupling region can reside outside the viewable area of a display. In a preferred embodiment the illumination film is

manufactured such that both the light coupling and light turning regions are created in the same step, e.g., via embossing. Other designs are also possible.

[0047] One embodiment of an interferometric modulator display comprising an interferometric MEMS display element is illustrated in Figure 1. In these devices, the pixels are in either a bright or dark state. In the bright (“on” or “open”) state, the display element reflects a large portion of incident visible light to a user. When in the dark (“off” or “closed”) state, the display element reflects little incident visible light to the user. Depending on the embodiment, the light reflectance properties of the “on” and “off” states may be reversed. MEMS pixels can be configured to reflect predominantly at selected colors, allowing for a color display in addition to black and white.

[0048] Figure 1 is an isometric view depicting two adjacent pixels in a series of pixels of a visual display, wherein each pixel comprises a MEMS interferometric modulator. In some embodiments, an interferometric modulator display comprises a row/column array of these interferometric modulators. Each interferometric modulator includes a pair of reflective layers positioned at a variable and controllable distance from each other to form a resonant optical gap with at least one variable dimension. In one embodiment, one of the reflective layers may be moved between two positions. In the first position, referred to herein as the relaxed position, the movable reflective layer is positioned at a relatively large distance from a fixed partially reflective layer. In the second position, referred to herein as the actuated position, the movable reflective layer is positioned more closely adjacent to the partially reflective layer. Incident light that reflects from the two layers interferes constructively or destructively depending on the position of the movable reflective layer, producing either an overall reflective or non-reflective state for each pixel.

[0049] The depicted portion of the pixel array in Figure 1 includes two adjacent interferometric modulators 12a and 12b. In the interferometric modulator 12a on the left, a movable reflective layer 14a is illustrated in a relaxed position at a predetermined distance from an optical stack 16a, which includes a partially reflective layer. In the interferometric modulator 12b on the right, the movable reflective layer 14b is illustrated in an actuated position adjacent to the optical stack 16b.

[0050] The optical stacks 16a and 16b (collectively referred to as optical stack 16), as referenced herein, typically comprise several fused layers, which can include an electrode layer, such as indium tin oxide (ITO), a partially reflective layer, such as chromium, and a transparent dielectric. The optical stack 16 is thus electrically conductive, partially transparent, and partially reflective, and may be fabricated, for example, by depositing one or more of the above layers onto a transparent substrate 20. The partially reflective layer can be formed from a variety of materials that are partially reflective such as various metals, semiconductors, and dielectrics. The partially reflective layer can be formed of one or more layers of materials, and each of the layers can be formed of a single material or a combination of materials.

[0051] In some embodiments, the layers of the optical stack 16 are patterned into parallel strips, and may form row electrodes in a display device as described further below. The movable reflective layers 14a, 14b may be formed as a series of parallel strips of a deposited metal layer or layers (orthogonal to the row electrodes of 16a, 16b) deposited on top of posts 18 and an intervening sacrificial material deposited between the posts 18. When the sacrificial material is etched away, the movable reflective layers 14a, 14b are separated from the optical stacks 16a, 16b by a defined gap 19. A highly conductive and reflective material such as aluminum may be used for the reflective layers 14, and these strips may form column electrodes in a display device.

[0052] With no applied voltage, the gap 19 remains between the movable reflective layer 14a and optical stack 16a, with the movable reflective layer 14a in a mechanically relaxed state, as illustrated by the pixel 12a in Figure 1. However, when a potential difference is applied to a selected row and column, the capacitor formed at the intersection of the row and column electrodes at the corresponding pixel becomes charged, and electrostatic forces pull the electrodes together. If the voltage is high enough, the movable reflective layer 14 is deformed and is forced against the optical stack 16. A dielectric layer (not illustrated in this Figure) within the optical stack 16 may prevent shorting and control the separation distance between layers 14 and 16, as illustrated by pixel 12b on the right in Figure 1. The behavior is the same regardless of the polarity of the applied potential difference. In this way, row/column actuation that can control the reflective vs. non-reflective pixel states is analogous in many ways to that used in conventional LCD and other display technologies.

[0053] Figures 2 through 5B illustrate one exemplary process and system for using an array of interferometric modulators in a display application.

[0054] Figure 2 is a system block diagram illustrating one embodiment of an electronic device that may incorporate aspects of the invention. In the exemplary embodiment, the electronic device includes a processor 21 which may be any general purpose single- or multi-chip microprocessor such as an ARM, Pentium[®], Pentium II[®], Pentium III[®], Pentium IV[®], Pentium[®] Pro, an 8051, a MIPS[®], a Power PC[®], an ALPHA[®], or any special purpose microprocessor such as a digital signal processor, microcontroller, or a programmable gate array. As is conventional in the art, the processor 21 may be configured to execute one or more software modules. In addition to executing an operating system, the processor may be configured to execute one or more software applications, including a web browser, a telephone application, an email program, or any other software application.

[0055] In one embodiment, the processor 21 is also configured to communicate with an array driver 22. In one embodiment, the array driver 22 includes a row driver circuit 24 and a column driver circuit 26 that provide signals to a display array or panel 30. The cross section of the array illustrated in Figure 1 is shown by the lines 1-1 in Figure 2. For MEMS interferometric modulators, the row/column actuation protocol may take advantage of a hysteresis property of these devices illustrated in Figure 3. It may require, for example, a 10 volt potential difference to cause a movable layer to deform from the relaxed state to the actuated state. However, when the voltage is reduced from that value, the movable layer maintains its state as the voltage drops back below 10 volts. In the exemplary embodiment of Figure 3, the movable layer does not relax completely until the voltage drops below 2 volts. Thus, there exists a window of applied voltage, about 3 to 7 V in the example illustrated in Figure 3, within which the device is stable in either the relaxed or actuated state. This is referred to herein as the "hysteresis window" or "stability window." For a display array having the hysteresis characteristics of Figure 3, the row/column actuation protocol can be designed such that during row strobing, pixels in the strobed row that are to be actuated are exposed to a voltage difference of about 10 volts, and pixels that are to be relaxed are exposed to a voltage difference of close to zero volts. After the strobe, the pixels are exposed to a steady state voltage difference of about 5 volts such that they remain in whatever state the row strobe put them in. After being written, each pixel sees a potential difference

within the “stability window” of 3-7 volts in this example. This feature makes the pixel design illustrated in Figure 1 stable under the same applied voltage conditions in either an actuated or relaxed pre-existing state. Since each pixel of the interferometric modulator, whether in the actuated or relaxed state, is essentially a capacitor formed by the fixed and moving reflective layers, this stable state can be held at a voltage within the hysteresis window with almost no power dissipation. Essentially no current flows into the pixel if the applied potential is fixed.

[0056] In typical applications, a display frame may be created by asserting the set of column electrodes in accordance with the desired set of actuated pixels in the first row. A row pulse is then applied to the row 1 electrode, actuating the pixels corresponding to the asserted column lines. The asserted set of column electrodes is then changed to correspond to the desired set of actuated pixels in the second row. A pulse is then applied to the row 2 electrode, actuating the appropriate pixels in row 2 in accordance with the asserted column electrodes. The row 1 pixels are unaffected by the row 2 pulse, and remain in the state they were set to during the row 1 pulse. This may be repeated for the entire series of rows in a sequential fashion to produce the frame. Generally, the frames are refreshed and/or updated with new display data by continually repeating this process at some desired number of frames per second. A wide variety of protocols for driving row and column electrodes of pixel arrays to produce display frames are also well known and may be used in conjunction with the present invention.

[0057] Figures 4, 5A, and 5B illustrate one possible actuation protocol for creating a display frame on the 3x3 array of Figure 2. Figure 4 illustrates a possible set of column and row voltage levels that may be used for pixels exhibiting the hysteresis curves of Figure 3. In the Figure 4 embodiment, actuating a pixel involves setting the appropriate column to $-V_{\text{bias}}$, and the appropriate row to $+\Delta V$, which may correspond to -5 volts and +5 volts, respectively. Relaxing the pixel is accomplished by setting the appropriate column to $+V_{\text{bias}}$, and the appropriate row to the same $+\Delta V$, producing a zero volt potential difference across the pixel. In those rows where the row voltage is held at zero volts, the pixels are stable in whatever state they were originally in, regardless of whether the column is at $+V_{\text{bias}}$, or $-V_{\text{bias}}$. As is also illustrated in Figure 4, it will be appreciated that voltages of opposite polarity than those described above can be used, e.g., actuating a pixel can involve setting the appropriate column to $+V_{\text{bias}}$, and the appropriate row to $-\Delta V$. In this embodiment, releasing the pixel is accomplished by setting the appropriate

column to $-V_{\text{bias}}$, and the appropriate row to the same $-\Delta V$, producing a zero volt potential difference across the pixel.

[0058] Figure 5B is a timing diagram showing a series of row and column signals applied to the 3x3 array of Figure 2 which will result in the display arrangement illustrated in Figure 5A, where actuated pixels are non-reflective. Prior to writing the frame illustrated in Figure 5A, the pixels can be in any state, and in this example, all the rows are at 0 volts, and all the columns are at +5 volts. With these applied voltages, all pixels are stable in their existing actuated or relaxed states.

[0059] In the Figure 5A frame, pixels (1,1), (1,2), (2,2), (3,2) and (3,3) are actuated. To accomplish this, during a "line time" for row 1, columns 1 and 2 are set to -5 volts, and column 3 is set to +5 volts. This does not change the state of any pixels, because all the pixels remain in the 3-7 volt stability window. Row 1 is then strobed with a pulse that goes from 0, up to 5 volts, and back to zero. This actuates the (1,1) and (1,2) pixels and relaxes the (1,3) pixel. No other pixels in the array are affected. To set row 2 as desired, column 2 is set to -5 volts, and columns 1 and 3 are set to +5 volts. The same strobe applied to row 2 will then actuate pixel (2,2) and relax pixels (2,1) and (2,3). Again, no other pixels of the array are affected. Row 3 is similarly set by setting columns 2 and 3 to -5 volts, and column 1 to +5 volts. The row 3 strobe sets the row 3 pixels as shown in Figure 5A. After writing the frame, the row potentials are zero, and the column potentials can remain at either +5 or -5 volts, and the display is then stable in the arrangement of Figure 5A. It will be appreciated that the same procedure can be employed for arrays of dozens or hundreds of rows and columns. It will also be appreciated that the timing, sequence, and levels of voltages used to perform row and column actuation can be varied widely within the general principles outlined above, and the above example is exemplary only, and any actuation voltage method can be used with the systems and methods described herein.

[0060] Figures 6A and 6B are system block diagrams illustrating an embodiment of a display device 40. The display device 40 can be, for example, a cellular or mobile telephone. However, the same components of display device 40 or slight variations thereof are also illustrative of various types of display devices such as televisions and portable media players.

[0061] The display device 40 includes a housing 41, a display 30, an antenna 43, a speaker 45, an input device 48, and a microphone 46. The housing 41 is generally formed from

any of a variety of manufacturing processes as are well known to those of skill in the art, including injection molding and vacuum forming. In addition, the housing 41 may be made from any of a variety of materials, including, but not limited to, plastic, metal, glass, rubber, and ceramic, or a combination thereof. In one embodiment, the housing 41 includes removable portions (not shown) that may be interchanged with other removable portions of different color, or containing different logos, pictures, or symbols.

[0062] The display 30 of exemplary display device 40 may be any of a variety of displays, including a bi-stable display, as described herein. In other embodiments, the display 30 includes a flat-panel display, such as plasma, EL, OLED, STN LCD, or TFT LCD as described above, or a non-flat-panel display, such as a CRT or other tube device, as is well known to those of skill in the art. However, for purposes of describing the present embodiment, the display 30 includes an interferometric modulator display, as described herein.

[0063] The components of one embodiment of exemplary display device 40 are schematically illustrated in Figure 6B. The illustrated exemplary display device 40 includes a housing 41 and can include additional components at least partially enclosed therein. For example, in one embodiment, the exemplary display device 40 includes a network interface 27 that includes an antenna 43, which is coupled to a transceiver 47. The transceiver 47 is connected to a processor 21, which is connected to conditioning hardware 52. The conditioning hardware 52 may be configured to condition a signal (e.g., filter a signal). The conditioning hardware 52 is connected to a speaker 45 and a microphone 46. The processor 21 is also connected to an input device 48 and a driver controller 29. The driver controller 29 is coupled to a frame buffer 28 and to an array driver 22, which in turn is coupled to a display array 30. A power supply 50 provides power to all components as required by the particular exemplary display device 40 design.

[0064] The network interface 27 includes the antenna 43 and the transceiver 47 so that the exemplary display device 40 can communicate with one or more devices over a network. In one embodiment, the network interface 27 may also have some processing capabilities to relieve requirements of the processor 21. The antenna 43 is any antenna known to those of skill in the art for transmitting and receiving signals. In one embodiment, the antenna transmits and receives RF signals according to the IEEE 802.11 standard, including IEEE 802.11(a), (b), or (g).

In another embodiment, the antenna transmits and receives RF signals according to the BLUETOOTH standard. In the case of a cellular telephone, the antenna is designed to receive CDMA, GSM, AMPS, or other known signals that are used to communicate within a wireless cell phone network. The transceiver 47 pre-processes the signals received from the antenna 43 so that they may be received by and further manipulated by the processor 21. The transceiver 47 also processes signals received from the processor 21 so that they may be transmitted from the exemplary display device 40 via the antenna 43.

[0065] In an alternative embodiment, the transceiver 47 can be replaced by a receiver. In yet another alternative embodiment, network interface 27 can be replaced by an image source, which can store or generate image data to be sent to the processor 21. For example, the image source can be a digital video disc (DVD) or a hard-disc drive that contains image data, or a software module that generates image data.

[0066] Processor 21 generally controls the overall operation of the exemplary display device 40. The processor 21 receives data, such as compressed image data from the network interface 27 or an image source, and processes the data into raw image data or into a format that is readily processed into raw image data. The processor 21 then sends the processed data to the driver controller 29 or to frame buffer 28 for storage. Raw data typically refers to the information that identifies the image characteristics at each location within an image. For example, such image characteristics can include color, saturation, and gray-scale level.

[0067] In one embodiment, the processor 21 includes a microcontroller, CPU, or logic unit to control operation of the exemplary display device 40. Conditioning hardware 52 generally includes amplifiers and filters for transmitting signals to the speaker 45, and for receiving signals from the microphone 46. Conditioning hardware 52 may be discrete components within the exemplary display device 40, or may be incorporated within the processor 21 or other components.

[0068] The driver controller 29 takes the raw image data generated by the processor 21 either directly from the processor 21 or from the frame buffer 28 and reformats the raw image data appropriately for high speed transmission to the array driver 22. Specifically, the driver controller 29 reformats the raw image data into a data flow having a raster-like format, such that it has a time order suitable for scanning across the display array 30. Then the driver controller 29

sends the formatted information to the array driver 22. Although a driver controller 29, such as a LCD controller, is often associated with the system processor 21 as a stand-alone Integrated Circuit (IC), such controllers may be implemented in many ways. They may be embedded in the processor 21 as hardware, embedded in the processor 21 as software, or fully integrated in hardware with the array driver 22.

[0069] Typically, the array driver 22 receives the formatted information from the driver controller 29 and reformats the video data into a parallel set of waveforms that are applied many times per second to the hundreds and sometimes thousands of leads coming from the display's x-y matrix of pixels.

[0070] In one embodiment, the driver controller 29, array driver 22, and display array 30 are appropriate for any of the types of displays described herein. For example, in one embodiment, driver controller 29 is a conventional display controller or a bi-stable display controller (e.g., an interferometric modulator controller). In another embodiment, array driver 22 is a conventional driver or a bi-stable display driver (e.g., an interferometric modulator display). In one embodiment, a driver controller 29 is integrated with the array driver 22. Such an embodiment is common in highly integrated systems such as cellular phones, watches, and other small area displays. In yet another embodiment, display array 30 is a typical display array or a bi-stable display array (e.g., a display including an array of interferometric modulators).

[0071] The input device 48 allows a user to control the operation of the exemplary display device 40. In one embodiment, input device 48 includes a keypad, such as a QWERTY keyboard or a telephone keypad, a button, a switch, a touch-sensitive screen, or a pressure- or heat-sensitive membrane. In one embodiment, the microphone 46 is an input device for the exemplary display device 40. When the microphone 46 is used to input data to the device, voice commands may be provided by a user for controlling operations of the exemplary display device 40.

[0072] Power supply 50 can include a variety of energy storage devices as are well known in the art. For example, in one embodiment, power supply 50 is a rechargeable battery, such as a nickel-cadmium battery or a lithium ion battery. In another embodiment, power supply 50 is a renewable energy source, a capacitor, or a solar cell including a plastic solar cell, and

solar-cell paint. In another embodiment, power supply 50 is configured to receive power from a wall outlet.

[0073] In some embodiments, control programmability resides, as described above, in a driver controller which can be located in several places in the electronic display system. In some embodiments, control programmability resides in the array driver 22. Those of skill in the art will recognize that the above-described optimizations may be implemented in any number of hardware and/or software components and in various configurations.

[0074] The details of the structure of interferometric modulators that operate in accordance with the principles set forth above may vary widely. For example, Figures 7A-7E illustrate five different embodiments of the movable reflective layer 14 and its supporting structures. Figure 7A is a cross section of the embodiment of Figure 1, where a strip of metal material 14 is deposited on orthogonally extending supports 18. In Figure 7B, the moveable reflective layer 14 is attached to supports at the corners only, on tethers 32. In Figure 7C, the moveable reflective layer 14 is suspended from a deformable layer 34, which may comprise a flexible metal. The deformable layer 34 connects, directly or indirectly, to the substrate 20 around the perimeter of the deformable layer 34. These connections are herein referred to as support posts. The embodiment illustrated in Figure 7D has support post plugs 42 upon which the deformable layer 34 rests. The movable reflective layer 14 remains suspended over the gap, as in Figures 7A-7C, but the deformable layer 34 does not form the support posts by filling holes between the deformable layer 34 and the optical stack 16. Rather, the support posts are formed of a planarization material, which is used to form support post plugs 42. The embodiment illustrated in Figure 7E is based on the embodiment shown in Figure 7D, but may also be adapted to work with any of the embodiments illustrated in Figures 7A-7C, as well as additional embodiments not shown. In the embodiment shown in Figure 7E, an extra layer of metal or other conductive material has been used to form a bus structure 44. This allows signal routing along the back of the interferometric modulators, eliminating a number of electrodes that may otherwise have had to be formed on the substrate 20.

[0075] In embodiments such as those shown in Figure 7, the interferometric modulators function as direct-view devices, in which images are viewed from the front side of the transparent substrate 20, the side opposite to that upon which the modulator is arranged. In

these embodiments, the reflective layer 14 optically shields the portions of the interferometric modulator on the side of the reflective layer opposite the substrate 20, including the deformable layer 34. This allows the shielded areas to be configured and operated upon without negatively affecting the image quality. Such shielding allows the bus structure 44 in Figure 7E, which provides the ability to separate the optical properties of the modulator from the electromechanical properties of the modulator, such as addressing and the movements that result from that addressing. This separable modulator architecture allows the structural design and materials used for the electromechanical aspects and the optical aspects of the modulator to be selected and to function independently of each other. Moreover, the embodiments shown in Figures 7C-7E have additional benefits deriving from the decoupling of the optical properties of the reflective layer 14 from its mechanical properties, which are carried out by the deformable layer 34. This allows the structural design and materials used for the reflective layer 14 to be optimized with respect to the optical properties, and the structural design and materials used for the deformable layer 34 to be optimized with respect to desired mechanical properties.

[0076] Interferometric modulators can be configured into many types of reflective displays which use ambient light to convey information from the display. As described above, in conditions of low ambient light, an illumination apparatus can be used to illuminate a reflective interferometric modulator display. For example, Figure 8 illustrates one embodiment of a front illumination device 80 that can be used to illuminate a reflective interferometric modulator display 84. The front illumination device 80 can include a light source 82 and a front illuminator 81, a light guide comprising for example, one or more film, film stack, sheet, or slab-like component. This front illuminator 81 includes turning features 85 that direct light propagating in the light guide onto the interferometric modulator display 84. The light source 82 is coupled to an edge 83 of the light guide 81 ("edge-coupled") to provide light to interferometric modulators configured in a reflective display 84. A portion of light emitted by the light source 82 enters the edge 83 of the light guide 81 and propagates throughout the light guide 81 utilizing the phenomenon of total internal reflection. As described above, the light guide 81 can include turning features 85 that re-direct a portion of the light propagating through the film towards the display 84. The front illuminator/light guide 81 is relatively thick edge to provide a large enough

edge 83 to receive light from the light source 82. However, this configuration causes the illumination to device 80 be relatively thick to accommodate the light guide 81.

[0077] As market forces dictate providing increasingly thinner display modules, each of the display components are subject to pressure to reduce thickness. Reducing the thickness of a front illumination device 80 typically requires reducing the thickness of the light source 82. While the front illuminator/light guide 81 can be made thinner, there are practical limitations to how thin light sources can be made. In one example, a LED has a light emitting die thickness of 0.2 - 0.3 mm, and the LED package further adds to this thickness. For edge-coupled embodiments, reducing the thickness of the light guide 81 beyond that of the light source 82 leads to inefficient optical coupling of the light source to the light guide because not all the emitted light can be delivered into the light guide 81. This is due to the physical size mismatch between the emitting aperture of the light source 82 and the input aperture (edge surface 83) of the light guide 81, which may comprise a film or film stack in some embodiments. Accordingly, reducing the thickness of a light guide 81 involves a tradeoff between having a suitably a thin light guide, e.g., a thin film or film stack, and having light injection efficiency.

[0078] Figure 9A illustrates an example embodiment of an illumination device with both a surface coupling section and a light turning section that overcomes the above-discussed problems of edge-coupled embodiments. The embodiment can include light coupling of various means (specific illustrations of which are described below) to couple a light source through the surface of a front illumination device that propagates the light to a reflective interferometric modulator display (or another type of reflective display). The embodiment in Figure 9A includes a front illumination device 90 having a light guide 91 placed "above" an interferometric modulator display 84 so that the light guide 91 is between the interferometric display 84 and ambient light illuminating the display. The light guide 91 is typically a substantially planar structure that may comprise one or more films, film stacks, sheets, or slab-like components. Although the light guide is described herein as substantially "planar," it is appreciated that the light guide, or portions of the light guide, may have surface features for reflecting, diffracting, refracting, or scattering light, or providing light using light emitting materials, such that the light guide surface may not be smooth.

[0079] The front illumination device 90 includes a light turning section 94 which comprises a portion of the light guide 91. The light turning section 94 may also be referred to herein as the “illumination section” or “region” which operates to illuminate or distribute light across the reflective display 84. The light turning section 94 has a “front” surface facing outward towards any ambient light, and a “back” surface facing inwards towards the reflective display 84. The light turning section 94 may include one or more light turning features 85. The light turning features 85 illustrated in Figure 9A comprise prismatic features. However, in other embodiments, other reflective, diffractive (including volume holographic diffraction gratings) or other types of light-redirection structures can be used. Light turning features 85 can be configured having consistent or varied spacing and/or periodicity, and be of different relative size and shape than those illustrated in Figure 9A. Light turning features in the light turning section 94 can be disposed on or near the front or back surface of the light turning guide 94 (e.g., disposed inside the light turning section 94 near the surface). The light turning section 94 is positioned over the display 84 such that the light turning features 85 can direct light to interferometric modulator pixels in the display 84.

[0080] The illumination device 90 also includes a light coupler section 92 and a light source 82. The light coupler section 92 comprises a portion of the light guide 91 which receives optical energy (generally referred to herein as “light”) from the light source 82. It is appreciated that in some examples described herein the emission from a light source may be in the visible spectrum and in other cases it may be in the non-visible spectrum (e.g., UV), and references to a light source emission (e.g., “optical energy” or “light”) should not be limited to just the visible spectrum). The light source 82 is positioned to provide light into the light coupler section 92. Specifically, the configuration and/or position of the light source 82, and the configuration of the light coupler section 92, allows light to enter a surface of the light guide 91 in the light coupler section 92, where the surface is a surface other than, or in addition to, the edge of the light guide 91.

[0081] In some embodiments, the surface of the light guide 91 that receives the emitted light is the surface proximal to the display 84, as shown in Figure 9A. In some embodiments, a light source 82 is positioned to emit light to a surface of the light guide 91 distal to the display 84. As used herein, the proximal surface of the light guide 91 refers to the back

surface that is adjacent to the display 84, and the distal surface refers to the surface of the light guide 91 that is positioned away from the display 84, that is, the surface of the light guide 91 that normally receives ambient light. In one example, the light source 82 is disposed on the opposite side of the light coupler section 92 as illustrated in Figure 9B. However, such an embodiment may result in a thicker display. In certain embodiments (for example as illustrated in Figure 9A) the surface which receives the light from the light source 82 is (substantially) parallel to the display 84 and is located outside of the display 84 viewing area. The light coupler section 92 can include a variety of coupling means to receive light from the light source 82 and direct the light to propagate into the light turning section 94 of the illuminator 91. Light entering the light guide 91 can be diffracted, reflected, scattered, or absorbed and re-emitted by optical features, surface volume structures and/or structured coatings incorporated within the coupler region 92 of the light guide 91. Such features, surface volume structures and structural coatings can be disposed inside or on a surface of the light coupler section 92. At least some of the coupled light propagates throughout the light guide 91 through total internal reflection. As light propagates through the light guide 91, a portion of the light reflects off of one or more of the light turning features 85 in the light guide 91 and propagates to a display 84. The display 84 can comprise interferometric display elements, which reflect or absorb the light depending on their interferometric state.

[0082] The light source 82 can comprise one or more light emitting elements, for example, an LED, a light bar, or a cold cathode florescent lamp (CCFL). In some embodiments, a single LED is used while in other embodiments up to five or more LED's are used. In some embodiments, the light source 82 emits light directly into the light coupler section 92. In some embodiments, the light source 82 includes a light emitting element and a light spreading element (e.g., a light bar) which receives the light from one or more light emitting elements, (e.g., such as a single LED), which are effectively point sources and provides the light to the light coupler section 92 as a line source. The light is then received by light coupler section 92 and then is sent through the light guide 91, being transformed from the line source into a distributed area source so as to provide sufficiently uniform illumination across the display 84. Using a single light emitting element can lower power consumption. In other embodiments, a plurality of colored LEDs are used in the light source 82 to form white light. A light spreading element can include

diffusing material (e.g., a volume diffuser containing particles, pigments, etc.) and light directing structures that facilitate transforming a received point source light, or numerous point sources, into a line light source. In some embodiments, the light coupler section 92 contains diffusing material and light directing structures so that light from the light source interacts with the diffusing material and light structures before the light enters the light guide 91.

[0083] Some embodiments include a reflector 93 positioned partially around the light coupler section 92 and the light source 82. Shown from an end view in Figure 9A, the reflector 93 can be configured as a U-shaped or rectangular shaped structure. The reflector 93 can be positioned along a portion or the entire length of a light source 82 which runs along one edge of the display in the light coupler section 92. In some embodiments, the far end of the reflector 93 is closed to reflect light emitted from the coupler section 92 back into the light coupler section 92. The reflector can be placed in various locations and proximities with respect to the light coupler section 92 and the light source 82. In some embodiments, the reflector closely conforms to the surface of the light coupler section 92 and the light source 82. The reflector 93 can comprise suitable reflective metallic material, for example, aluminum or silver, or the reflector 93 can comprise a nonmetallic reflective material, films, or structures.

[0084] The reflector 93 can increase the coupling efficiency by redirecting light propagating out of the light coupler section 92 back into the light coupler section 92 for further interaction with the coupling microstructure. In one example, light from the light source 82 enters the light coupler section 92 and propagates to a diffraction grating disposed in the light coupler section 92. Some of the light is diffracted to the right (towards the display 84), and some of the light is diffracted to the left towards the reflector 93 as illustrated in Figure 9A. A certain portion of light can travel straight through and exits the light coupler section 92. Light diffracted to the left in Figure 9A (away from the display) may be reflected internally within the light guide 91 and remain therein, but some light may exit the light guide 91. The reflector 93 can be positioned to reflect light emitted from the light coupler section back towards the light coupler section 92 such that it re-enters the light guide 91 and propagates towards the display 84. The reflector 93 can be shaped to maximize the amount of light reflected back towards the light guide 91. For example, the reflector 93 can be "U"-shaped or parabolically shaped. A reflector 93 may be used in any of the embodiments described herein to increase the light coupling efficiency. In

an embodiment, the surface of the reflector 93 is a specular reflector. In another embodiment, the reflector 93 comprises diffusely reflecting surfaces.

[0085] Illustrative surface coupling embodiments are described below in reference to Figures 10-21, and generally include reflective and transmissive surface diffractive gratings (Figures 10-13, 16-17), volume diffractive gratings (Figures 14-15, 18, 22, 23), prismatic devices (Figure 19A and 19B), and light scattering and/or light absorption and re-emission based devices (Figures 20-21). Such embodiments are sometimes generally referred to herein as “surface couplers,” because light is coupled primarily through the top or bottom surface of the light guide 91 and not through the edge 83 of the light guide as shown in Figure 8, or only minimally through the edge 83 in the presence of a reflector as shown in Figure 9A and 9B. The various illustrative embodiments illustrating coupling a light through the surface of a thin light guide can include using surface diffractive microstructures, surface diffractive reflectors, volume diffractive holographic recordings, prismatic microstructures, light scattering and/or emission-based elements to couple light from a light source 82 to an illuminator light guide 91 to provide a front light to a reflective display. In such embodiments, the light coupling section 92 can reside outside the viewable area of the display. The front illuminator light guide 91 can be manufactured such that both a light coupling section 92 and a light turning section 94 are created in the same step, e.g., via embossing a plastic film.

[0086] For ease of illustration, in the embodiments of couplers illustrated in Figures 10-15, only the light coupler portion 92 of the front illumination light guide 91 is shown. However, each embodiment can also include a light turning section 94 and a display 84 (Figure 9A).

[0087] Referring now to Figure 10, in some embodiments the light coupler section 92 includes a surface diffraction grating 102 configured on the proximal surface 104 of the light guide 91, e.g., the surface that is subsequently parallel to and adjacent to the light source. The surface diffraction grating 102 diffracts light from a light source 82 into the light guide 91. In Figure 10 the surface diffraction grating 102 is used in a transmission mode so that light diffracts as it passes through the diffraction grating. The light is diffracted such that at least a portion of the diffracted light is directed into the light guide 91 at an angle where it propagates through the light guide 91 by total internal reflection (TIR).

[0088] The particular placement and orientation of the surface diffraction grating 102 can vary depending on, for instance, the particular implementation and manufacturing criteria. In some embodiments, the diffraction grating 102 is formed in a thin film of a light coupler section stack. In some embodiments, the surface diffraction grating 102 is embossed or etched on the proximal surface 104 of the light guide 91. The periodicity of the diffraction grating can be advantageously selected based on the wavelength of the received light to increase or maximize the light that is diffracted at an angle into the light guide 91 so that it propagates throughout the light guide 91 via TIR. Typically there are multiple periodicities in the diffraction grating so that many or all wavelengths of visible light are diffracted in useful directions. In some embodiments, the “diffraction grating” includes diffraction structures of different orientations and different periodicities so as to couple light incident at multiple angles onto the coupler section.

[0089] Figure 11 illustrates another embodiment of a surface diffraction grating 112 used in a reflection diffraction mode. In this embodiment, the light source 82 provides light through a proximal (or near) surface 104 of the light coupler section 92. The light propagates to the surface diffraction grating 112 disposed on a distal surface 116 of the light guide 91. The diffraction grating 112 redirects the light in various directions inside the light guide 91. The directions depend on the periodicities of the diffraction grating, the wavelength and incidence direction of the received light from the light source 82. The diffraction grating 112 can be configured such that at least a portion of the reflected light propagates throughout the light guide by total internal reflection. In some embodiments, the periodicities of the diffraction grating 112 is selected in conjunction with the selection of the light source 82 so as to increase or optimize the portion of light reflected from the diffraction grating 112 at an angle advantageous for TIR within the light guide 91. In some embodiments, a coating 114 is placed on the distal side of the diffractive grating 112 to improve reflectivity. The coating 114 can be any suitable reflective coating including a metallic coating. In some embodiments, the reflective coating 114 comprises vapor deposited aluminum or silver. In some embodiments, the reflective coating can be formed from wet printed metallic ink (e.g., silver-nanoparticle based ink) or the like. In similar embodiments to those illustrated in Figures 10 and 11, the coupler region 92 can comprise a 2-D mosaic of 1D surface diffraction gratings (e.g., a 2-D arrangement of patches, or domains, each

containing a 1D surface diffraction with varying periods and/or orientations) which allows the coupler to operate over multiple wavelengths, and for non-collimated input light sources.

[0090] Figures 12 and 13 illustrate embodiment of surface coupling using a blazed diffraction grating 122 on the near surface 104 and in the light coupler section 92 of a light guide 91. Figure 12 illustrates the blazed diffraction grating 122 used in a transmission configuration, where Figure 13 illustrates a blazed diffraction grating 132 used in a reflection configuration. A blazed diffraction grating can be an echelette (saw tooth) type of grating, wherein the grating is designed for maximum intensity at a desired region of the diffraction spectrum. The blazed diffraction grating improves the directionality of coupled light, directing light received from a light source 82 to propagate through the light guide 91 and to a display. In some embodiments, the blaze angle is selected in conjunction with the grating periodicity and with the light source 82 to determine the angle the received light is directed into the light guide 91.

[0091] Figure 13 also illustrates an embodiment of a light coupler section 92 that includes a blazed surface diffraction grating 132. The blazed surface diffraction grating 132 couples light from a light source 82 to a thin light guide 91. In Figure 13, the blazed diffraction grating 132 is configured as a surface diffraction grating in a reflection configuration, the blazed diffraction grating 132 being positioned on the far (or distal) surface 116 of the light guide 91. A light source 82 provides light to a near surface 104 of the light guide 91 and then to the blazed diffraction grating 132. The blazed diffraction grating 132 reflectively diffracts the light, a portion of which propagates through the light guide 91. The blazed surface provides an additional means to direct the reflected light into the light guide 91 so total internal reflection occurs, facilitating the light to propagate the display 84 (not shown). Here, and in Figure 12, blazing the diffraction grating can provide better control over the diffraction direction which can lead to a higher efficiency coupling between the light source 82 and the thin light guide 91 resulting in more light propagating through the light guide 91 and reaching a display 84. Use of blazed diffraction gratings allows the selection of both a blaze angle and a diffraction grating periodicity, in conjunction with the selection of a light source, to increase or optimize the light coupled into the light guide 91.

[0092] Figures 14 and 15 illustrate light coupling embodiments that include a volume diffraction grating. Specifically, Figure 14 illustrates a light coupler section 92 that includes a

volume diffraction grating 143 employed in a transmission configuration. Figure 15 illustrates a light coupler section 92 that includes a volume diffraction grating 153 employed in a reflection configuration. The volume diffraction gratings 143, 153 include a holographic recording medium 141 (e.g., a photosensitive gel, or photopolymer resin) sandwiched between two substrates or substrate portions 142, 144 and positioned within the light coupler section 92 of the light guide 91. In the transmission configuration shown in Figure 14, light from the light source 82 passes through the volume diffraction grating 143 and diffracts at an angle such that at least a portion of the diffracted light propagates through the light guide 91 and to a display (not shown) by total internal reflection. In the reflection configuration shown in Figure 15, light from the light source 82 reflectively diffracts from the volume diffraction grating 153 at an angle such that at least a portion of the reflected light propagates through the light guide 91 and to a display by total internal reflection.

[0093] In some embodiments, the volume diffraction gratings 143, 153 are volume phase holographic (“VPH”) diffraction gratings. Instead of physical grooves, the VPH diffraction gratings use a periodic modulation of the refractive index within the holographic recording medium 141. Using a volume holographic diffraction grating eliminates much of the surface contamination sensitivity typically seen in other surface diffraction gratings, and enables a facile control over the directionality of the light coupled into the light guide section of the device. The control over the directionality is achieved during the recording stage of the hologram by employing appropriately oriented beams and multiple recordings.

[0094] Figure 22 is a schematic illustrating an embodiment of a transmission hologram volume diffraction grating 143, such as the volume grating illustrated in Figure 14. The transmission volume diffraction grating 143 can be formed on the surface of the light coupler section 92 proximal to the light source 82. The light source 82 and the volume diffraction grating 143 are positioned such that at least a portion of light emitted by the light source 82 to the diffraction grating 143 is diffracted into the light guide 91. The hologram volume diffraction grating 143 may comprise a single layer or multiple layers. A multiple layer “stack” embodiment may comprise a base film carrying the photosensitive material. The stack can also comprise an adhesive which is used to laminate the hologram diffraction grating onto a surface, e.g., the light coupler section 92 of the light guide 91. This embodiment can include an

optional layer 145 formed between the light source 82 and the transmission volume diffraction grating 153. The layer 145 may comprise air or an optically matched adhesive layer (e.g., a pressure sensitive adhesive) that couples the light source with the hologram. Some embodiments may not include layer 145, for example, where light source 82 is directly in contact with the hologram diffraction grating 153 or the hologram itself could be formed in an adhesive type of holographic recording material.

[0095] Figure 23 is a schematic illustrating an embodiment of a reflection hologram volume diffraction grating 153, such as the volume diffraction grating 153 illustrated in Figure 15. The reflection volume diffraction grating 153 can be formed on the top surface of the light coupler section 92. In some embodiments, a reflector (for example, reflector 93 illustrated in Figure 9) may be positioned around the volume diffraction grating 153, the light source 82, and the light coupler section 92 to recycle light and increase the total efficiency of coupling light from source to light guide. In some embodiments, another optional layer 145 (discussed above in reference to Figure 22) may be formed between the light source 82 and the light guide 91.

[0096] Figures 16A, 16B, 17 and 18 illustrate examples of design and fabrication processes for diffractive couplers. Specifically, Figures 16A, 16B and 17 illustrate forming a reflection surface diffraction grating, such as illustrated in Figure 11. Figure 18 illustrates forming a volume diffraction grating illustrated, such as is illustrated in Figure 14. These and similar fabrication techniques can also be used to form other diffraction couplers. Of course, it is appreciated that other suitable fabrication techniques and processes can also be used to form such gratings.

[0097] Figures 16A and 16B illustrate a top view and a side view, respectively, of one embodiment of a display device 160 having a reflective diffractive coupler 92. Referring to Figures 16A and 16B, the display device 160 includes a light guide 91 with a light coupling section 92. The light guide 91 includes a light turning section 94 with prismatic structures 178 disposed on the surface distal to the display 84. A light source 82 is positioned to provide light to the light coupling section 92. The structures 178 on the light turning section 94 re-direct light provided by the light source 82 propagating through the light guide 91 towards the display 84. Such structures can include reflective surfaces (e.g., prismatic grooves) disposed in various patterns including lines, concentric circles, on curvilinear paths, or elliptical paths. In this

embodiment, a diffuser layer 164 is positioned between the illumination light guide 91 and an interferometric modulator display 84. The diffuser layer 164 is specifically selected for the specularly reflecting interferometric modulator display 84; other displays may have other additional layers or not have a diffuser layer. Also, certain additional layers and components can be included in the embodiment illustrated here that are not shown in these particular figures.

[0098] Figure 17 shows an exemplary process of making the diffractive coupler illustrated in Figure 16. This process involves two paths, one for making the light turning section 94 (illustrated on the right side of Figure 17) and another for making the coupler section 92 (illustrated on the left side of Figure 17). As illustrated in Figure 17, the fabrication begins with a substrate (or blank) 172, and the process follows the two paths to form the coupler section 92 and the light turning section 94. The substrate 172 preferably comprises crystalline silicon although other suitable materials can also be used.

[0099] Referring first to the fabrication of the light turning section 94 as illustrated on the right side of Figure 17, at Step 1 a mask is placed on the substrate 172 in a desired pattern to form light turning features. In one embodiment, a mask 174 is formed in by lithographically patterning a hard mask 174 onto the substrate 172. The mask 174 can comprise SiO_2 , Si_3N_4 or the like. The average spacing (period) 176 of the mask pattern can vary with particular implementations and affects the resulting light turning features 178 formed from the mask 174. The size or shape of the light turning features 178 may vary as a function of the distance from the light coupler section 92 in order to provide uniform illumination of the display 84. Functionally, the light turning features 178 operate like small light sources each illuminating a small area of the display 84. If the illuminated areas sufficiently overlap then the display appears evenly illuminated. In an illustrative embodiment a mask line can be patterned about every $10^4 - 10^6$ nm, preferably about every $10^4 - 10^5$ nm, so as to produce light turning features separated by this distance. The periodicity of the pattern can be constant, non-uniform or random, or it can decrease as a function of distance from the coupling section 92.

[0100] Still referring to the right-hand side of Figure 17, at Step 2, an anisotropic wet etch is performed on the substrate 172, etching into the substrate 172 to form the light turning features 178. The light turning features 178 can be grooves of various shapes or sizes formed in lines, circles or other patterns that are suitable for redirecting light propagating through the light

turning section 94 to the display 84 so that visible portions of the display 84 are evenly illuminated. Such grooves can be evenly spaced. Alternatively, the spacing can decrease as distance from the coupler section 92 increases so that more light turning features 178 are formed in the portion of the light turning section 94 farther from the coupler section 92. Also, the size of the light turning features 178 can increase as distance from the coupler section increases.

[0101] The solution used for the wet etch of a crystalline silicon substrate can comprise KOH:H₂O:IPA, a 25% solution of TMAH, or another suitable wet etchant, used at an appropriate temperature, e.g., between 25-90°C, preferably about 80°C. Finally, at Step 3 the wet etch mask 174 is removed from the substrate 172 using, for example, HF (wet) for a mask comprising SiO₂. After the light turning section 94 is etched into the substrate 172, the coupler section 92 can be fabricated while the light turning section 94 is protected, for example, by a temporary coating layer. The steps of the fabrication process can be performed in a different order, e.g., where the coupler section 92 is first etched into the substrate and then the light turning section 94 is formed. The process steps can also be intermixed.

[0102] The left side of Figure 17 illustrates an embodiment of the coupler section 92 fabrication process. At Step 1 the process lithographically patterns an etch mask 171 onto the substrate 172. The periodicity and structure of the mask pattern is set to form surface relief features that will determine the diffraction response. Because diffraction of light is based on its wavelength, the wavelength of the light source may be used to determine a suitable periodicity to diffract a relatively large portion of the light into the light guide 91 so that it propagates to the display 84. The periodicity of the pattern can be consistent along the length of the light guide 91 from the edge of the light guide 91 nearest the light coupler section 92 to the edge farthest from the light coupler section 92, or it can vary. Examples of mask material include photoresist, organic bottom antireflection layer (BARL), and SiO₂ for a Si substrate. At Step 2 an anisotropic dry etch is performed on the substrate 172 to etch the substrate 172 and form a diffraction grating 173. In some embodiments, the dry etching is done with reactive ion etching using CF₄ gas at low pressure (CF₄-RIE). At Step 3, the dry etch mask 171 is removed using, for example, O₂-plasma for an organic mask, or HF wet etching for an SiO₂ mask, leaving the surface diffraction grating 173.

[0103] The resulting etched substrate 175 includes microstructures that can be used to couple light into a thin light guide 91 and turn light propagating through the thin light guide to a display. The etched substrate 175 is a “positive” shape (the desired shape of the light guide) which can be used to make a negative replica. In some embodiments, the negative replica can be an electroformed metal foil which is then used for embossing illumination film, e.g., to form an illumination device 179 having a light guide 91 embossed with both the reflective surface diffraction grating and the light turning section. In some embodiments, the negative replica can be a mold, which is then used for injection molding processes.

[0104] The process illustrated in Figure 17 can also be used to form separate “master molds,” one mold having the coupler section 92 and another mold having the light turning section 94. Two portions of metal foil can be used to make separate negative replicas of each of the two master molds. In some embodiments, the two portions of metal foils can be joined to form a single negative replica, such that the stitch line falls outside the area of the device that will overlap with the viewing area of a display. The joined negative replica can then be replicated twice (such that the first replication produces a similar but inverted surface structure, and the second replication produces the original surface structure), and the second replication can then be used to make a mechanically robust metal electroform for embossing illumination film with the coupler section structures and the light turning section structures.

[0105] Figure 18 illustrates a process for recording a transmission mode volume diffraction grating, such as the volume diffraction grating illustrated in Figure 14. In Figure 18, both the coupler section 92 (illustrated on the left side of Figure 18) and the light turning section 94 (illustrated on the right side of Figure 18), are based on volume holograms. The orientation of the corresponding recording beams for each of the two sections is denoted by the wave vectors K_1 and K_2 , and the recorded (holographic) fringe periodicity direction is given by the difference vector, ΔK .

[0106] As illustrated in Figure 18, a holographic recording material 141 is optionally sandwiched between two substrates 142, 144. In some embodiments, either one of the substrates 142, 144 can be may not be present during recording, instead included after the holographic recording is made. The holographic recording material 141 can be a gel, a solid film, a light sensitive photopolymer resin, or the like. In some embodiments, the holographic recording

material has adhesive properties, or is a film comprising an adhesive, such that the recording material can be placed on one side of a substrate and a light guide film can be applied to cover the recording material, creating a film stack. Other configurations are also possible. The left-side of Figure 18 shows the formation of the coupler section which is done, for example, while protecting (masking) the rest of the light sensitive film, including the light turning section 94. The right-side of Figure 18 shows the formation of the light turning section, which is also done, for example, while protecting the light coupler section of the film. In practice, the tilted beams K_2 will be coupled via a prism index matched to the holographic material (so that light enters from air at normal incidence onto the prism surface), and the back of the film will be index matched to a bulk material as to prevent reflections from the back surface, which would create an unwanted set of holographic fringes in the reverse direction. In some embodiments, at least one of the recording beams will have an appropriately chosen divergence or convergence angle, such that the recorded hologram will be able to act upon a diverging light source.

[0107] As shown in Figure 18, the light turning section 94 uses the volume diffraction grating to redirect light propagating through the light turning section 94 towards a display. In some embodiments, the volume diffraction grating is the only light directing feature used. In other embodiments, the volume diffraction grating can be combined with other light directing features (e.g., prismatic features, reflectors, surface diffraction features, and the like) to direct light more efficiently to a display.

[0108] Figures 19A and 19B illustrate an exemplary embodiment of a light guide 91 that includes a light coupler section 92 comprising a prismatic lightbar-like coupler 190. Figure 19B shows the same embodiment as Figure 19A with a magnified view and illustrating light propagating through the prismatic coupler 190. Referring to Figures 19A and 19B, the light guide 91 has two sections – the light turning (illumination) section 94 which contains facets 197 predominantly parallel to a longitudinal direction along the length of the light bar 190, and the light coupler section 92 having facets 195 oriented at $+45^\circ$ from the longitudinal direction of the light bar. A light source 82 provides light into one end of a light bar 190 disposed along a coupler section 92. The light bar 190 and the coupler section 92 each include V-shaped prismatic grooves 193, 195 placed at a $+45$ and/or -45° orientation relative to the longitudinal direction of the light bar 190. The V-grooves 193, 195 are disposed on the lower surface 194 of the light bar

190, and on the upper surface 196 of the coupler section 92, and comprise sloping or angled surfaces that reflect light (e.g., via total internal reflection) provided by the light source 82 from the light bar 190 and into the coupler section 92. The V-grooves 195 in the coupler section 92 reflect the light from the light bar 190 into the light turning section 94. The light turning section 94 contains facets 197 that reflect light propagating through the light turning section 94 towards a display (not shown). In various implementations, the facets 197 can comprise a variety of structures having different shapes and orientations that can re-direct light propagating through the light turning section 94 towards a display.

[0109] The light bar 190 can be fabricated via injection molding in a cavity having a mold insert on one side containing the inverse surface microstructure of the V-shaped prismatic grooves 193. In one example, a V-grooved insert for the injection molding cavity can be fabricated by single-point diamond turning a set of parallel grooves, and then cutting a rectangular portion of the shim oriented at 45° from the groove direction. The fabrication of such a light guide 91 can be also be done by single point diamond tooling the two sections separately and joining the resulting sections into a single master shim, which is copied by electroforming to form a seamless master molding structure from which the light guide 91 can be formed. A second approach involves creating the V-grooves by anisotropic wet etching of silicon, followed by cutting at 45° and polishing the coupler section or simply cutting the illumination section. The well controlled thickness of silicon wafers greatly simplifies the step where the two sections are joined – the width of the seam region will be smaller than 1mm, which will be found outside the viewing area of the display. In some embodiments, a reflector (for example, reflector 93 illustrated in Figure 9) can be positioned around the light bar/light coupler section to direct any (or at least a portion of) stray light that has been emitted from the light guide 91 and/or the light bar 190 into the surrounding area back into the light guide 91 and/or light bar 190.

[0110] Figure 20 illustrates an exemplary embodiment that uses light emitting material to couple light into an illumination light guide 91. In this embodiment, the coupler section 92 includes a light emitting material that emits light when it is pumped by an external source. In this example, a light source 82 can be used to pump (excite) a photoluminescent material 202. Emissions from the photoluminescent material 202 propagate along the light guide to the illumination region. The light emitting material can be disposed within the light coupling

section 92 of the light guide 91, or on a front surface (as illustrated in figure 20), a back surface, or a side surface of the light guide 91 and disposed to receive light entering the light guide 91 from the light source 82. In some embodiments, light emitting material comprises particles capable of both light emission and light scattering.

[0111] In some embodiments, a reflector 204 can be placed on top of the photoluminescent material 202 to enhance the efficiency. The reflector 204 can comprise, for example, reflecting tape, metallic films, dielectric multilayers such as 3M's enhanced specular reflector, ESR, film, interference coatings, or other types of reflectors. The surface of the reflector 204 adjacent to the photoluminescent material 202 can be coated with white paint or another highly reflective material. The photoluminescent material 202 can be selected to match the light source 82 emitted light spectrum so as to absorb the light efficiently. The photoluminescent material 202 can comprise a light diffusing material and or light scattering material. In one example, the light source 82 is a UV, and the photoluminescent material 202 absorbs UV light and re-emits visible light in substantially all directions. A shaped metal reflector 204 can also increase the coupling efficiency to the illumination section of the light guide by sending at least a portion of the visible light emitting to the wrong directions into the illumination section .

[0112] In one embodiment, a blue-LED similar to those used for white-LEDs can be paired with a light emitting phosphor similar to those used to produce white light in white-LEDs. A UV-LED allows an even wider choice of photoluminescent materials (not only the same phosphors as those used in white-LED, but also mixtures of organic light emitting dyes or mixtures of inorganic quantum dots which allow an even finer control over the spectral composition of the final white light that is trapped in the film and guided towards the light emitting region). In terms of fabrication, this could be as simple as screen printing a "line" or a "pad" of phosphor in the coupler region of a front light film, followed by lamination of a reflecting tape that covers the printed material (compatible with roll-to-roll processing, and thus implementable downstream from the embossing of the illumination section into a plastic film).

[0113] In various embodiments, the light emitting material 202 comprises a photoluminescent reflecting phosphor material, which can be pumped, for example, by either a blue-LED light source 82 directly or via an LED light bar assembly. Longer wavelength spectral

components (e.g., green, red, etc.) are emitted by the phosphor and, when combined with the blue pump light, produce the spectrum of the white light. Both the longer wavelength emission and the shorter wavelength (e.g., blue) pump light are propagated along the light guide 91. The proportion of the different spectral components may be controlled to obtain the desired white light. To provide the correct proportion as to form “white” light, the phosphor may be diffusely reflecting so that the blue-light is reflected into a diffuse cone adjusted such that the intensity matches the cone of light emission from the excited phosphor. Part of the light from each of these cones is guided by the light guide 91. It is appreciated that other techniques can also be used to obtain the desired white light. In another embodiment, the light source 82 emits white light, and the material 202 is a simple diffuse reflecting material which is able to redirect a portion of the incoming light into the light guide 91. In this embodiment, a reflector 204 is preferred to be used for increasing the coupling efficiency into the light guide.

[0114] Figure 21 illustrates another embodiment of a light emission coupler based on surface plasmon resonances. This coupler section 92 comprises a thin corrugated metal film forming a diffraction grating 214 on a surface 212 of the light guide 91. Light emissive material 202 is disposed on the diffraction grating 212, and a metal film 216 is disposed thereon. For example, the light coupler section 92 may be formed in a light guide 91 comprising plastic by embossing the periodic surface relief structure 214 on the surface 212 distal to the light source 82 (to essentially form a diffraction grating), depositing the light emitting material 202 (e.g., luminescent or fluorescent molecules (e.g., laser dyes), or quantum dots) thereon, and conformally depositing a metal reflector 216 on top of the light emitting material 202. Preferably, the metal reflector 216 is a highly reflective material such as silver or aluminum. The light source 82 (e.g., a light bar) is used to excite the light emitting material 202, which transfer the energy to surface plasmon modes due to the physical proximity to the thin metallic film of the reflector 216. These surface plasmon modes radiate light directionally due to the periodicity of the metallic film structure (or corrugation). Accordingly, the emissive material couple energy into plasmons in the metal film. The plasmons couple energy into optical emission through the periodic structure, which can be adjusted to control the direction and wavelength of optical output.

[0115] In order to allow white light operation, the light emitting species can be chosen so as to emit across the entire visible spectrum (e.g., mixture of red, green, and blue emitters). The periodic surface relief structure may comprise a 2D mosaic containing “patches” with different periodicity and orientations such that the desired white light will be produced on average along the directions into which light is trapped by total internal reflection inside the light guide 91.

[0116] A wide variety of variation is possible. Films, layers, components, and/or elements may be added, removed, or rearranged. Additionally, processing steps may be added, removed, or reordered. Also, although the terms film and layer have been used herein, such terms as used herein include film stacks and multilayers. Such film stacks and multilayers may be adhered to other structures using adhesive or may be formed on other structures using deposition or in other manners.

[0117] The examples described above are merely exemplary and those skilled in the art may now make numerous uses of, and departures from, the above-described examples without departing from the inventive concepts disclosed herein. Various modifications to these examples may be readily apparent to those skilled in the art, and the generic principles defined herein may be applied to other examples, e.g., in an instant messaging service or any general wireless data communication applications, without departing from the spirit or scope of the novel aspects described herein. Thus, the scope of the disclosure is not intended to be limited to the examples shown herein but is to be accorded the widest scope consistent with the principles and novel features disclosed herein. The word “exemplary” is used exclusively herein to mean “serving as an example, instance, or illustration.” Any example described herein as “exemplary” is not necessarily to be construed as preferred or advantageous over other examples.

What is Claimed is:

1. An illumination device comprising:
a light guide comprising
a front surface;
a back surface;
a light coupling section configured to receive optical energy from a light source in to the light guide through said front surface or said back surface at an angle about normal to the optical energy receiving surface, and further configured to direct light through said light guide; and
a light turning section configured to redirect out of the light guide at least a portion of the light received from said light coupling section, said redirected light at an angle about normal to the optical energy receiving surface.
2. The device of claim 1, further comprising a light source disposed with respect to said light coupling portion to inject light into said light coupling portion.
3. The device of claim 2, wherein said light source is disposed adjacent to said optical energy receiving surface of the light coupling section such that at least a portion of the provided light is incident on said optical energy receiving surface at an angle about normal to said optical energy receiving surface.
4. The device of claim 1, wherein said light guide comprises a substantially planar sheet or film stack.
5. The device of claim 1, wherein said light coupling section comprises a diffractive optical element.
6. The device of claim 5, wherein said diffractive optical element comprises a diffraction grating.
7. The device of claim 5, wherein said diffractive optical element comprises surface diffractive features.
8. The device of claim 5, wherein said diffractive optical element comprises volume diffractive features.

9. The device of claim 5, wherein said diffractive optical element is contained within said light guide.

10. The device of claim 5, wherein said diffractive optical element is disposed on said front surface.

11. The device of claim 5, wherein said diffractive optical element is disposed on said back surface.

12. The device of claim 5, wherein said diffractive optical element is disposed on the optical energy receiving surface of said light guide.

13. The device of claim 6, wherein said diffraction grating is a transmissive diffraction grating.

14. The device of claim 6, wherein said diffraction grating is a reflective diffraction grating.

15. The device of claim 6, wherein said diffraction grating comprises a blazed grating.

16. The device of claim 1, wherein said light coupling section further comprises a light emissive material and a metal surface disposed adjacent to said light emissive material, said coupling section configured such that surface plasmon excitation occurs in said metal surface when said light emissive material is illuminated with said optical energy.

17. The device of claim 1, wherein said light coupling section comprises a photoluminescent material.

18. The device of claim 17, wherein the light coupling section further comprises a reflector disposed adjacent to said photoluminescent material to redirect light emitted therefrom into said light coupling section such that at least a portion of the redirected light propagates to said light turning section of said light guide.

19. The device of claim 17, further comprising a UV light source disposed with respect to said light coupling section to provide UV light to said optical energy receiving surface of said light coupling section such that at least a portion of UV light emitted from the light source can enter said light coupling section and propagate to said photoluminescent material.

20. The device of claim 1, wherein said light turning section comprises a plurality of turning features disposed on said front surface of the light guide.

21. The device of claim 1, wherein said light turning section comprises a plurality of turning features disposed on said back surface of the light guide.

22. The device of claim 1, wherein said light turning section comprises a plurality of turning features within said light guide.

23. The device of claim 1, wherein said light turning section comprises prismatic features configured to direct light out of the back surface of the light guide.

24. The device of claim 1, wherein said light turning section includes a holographic element configured to direct light out of the back surface of the light guide.

25. The device of claim 1, further comprising a reflector disposed adjacent to the light coupling section to reflect at least a portion of light emitted from said light coupling section back into said light coupling section.

26. The device of claim 1, further comprising a reflective spatial light modulator disposed substantially parallel to said back surface and adjacent to at least a portion of said light turning section.

27. The device of claim 26, wherein said reflective spatial light modulator comprises a plurality of interferometric modulators.

28. The device of claim 26, further comprising:

a processor that is configured to communicate with said spatial light modulator, said processor being configured to process image data; and

a memory device that is configured to communicate with said processor.

29. The device of claim 28, further comprising a driver circuit configured to send at least one signal to said spatial light modulator.

30. The device of claim 29, further comprising a controller configured to send at least a section of the image data to said driver circuit.

31. The device of claim 28, further comprising an image source module configured to send said image data to said processor.

32. The device of claim 31, wherein the image source module comprises at least one of a receiver, transceiver, and transmitter.

33. The device of claim 28, further comprising an input device configured to receive input data and to communicate said input data to said processor.

34. The device of claim 1, wherein said light coupling section comprises diffuse reflecting material disposed to redirect a portion of the received optical energy into light propagating in the light guide.

35. The device of claim 34, wherein said diffuse reflecting material is disposed within the light coupling section.

36. The device of claim 34, further comprising reflector disposed adjacent to said diffuse reflecting material to redirect a portion light reflected by said diffuse reflecting material towards said light turning section.

37. The device of claim 35, wherein said diffuse reflecting material is disposed on a surface of said light guide.

38. The device of claim 37, wherein said surface where diffuse reflecting material is disposed is the front surface of said light guide.

39. An illumination device comprising:

means for guiding light, said guiding light means having a front and a back surface, said light guiding means comprising

means for coupling optical energy that is received from a light source in to the light guiding means through said front surface or said back surface at an angle about normal to the optical energy receiving surface, and further configured to direct light through said light guiding means; and

means for turning light to redirect out of the light guiding means at least a portion of the light received from said coupling means, said redirected light at an angle about normal to the optical energy receiving surface.

40. The device of claim 39, further comprising further comprising means for modulating light disposed substantially parallel to said back surface and adjacent to at least a portion of said light turning means.

41. The device of claim 40, wherein said modulating means comprises a reflective spatial light modulator.

42. The device of claim 41, wherein said reflective spatial light modulator comprises a plurality of interferometric modulators.

43. The device of claim 39, wherein said light guiding means comprises a light guide.

44. The device of claim 31, wherein said optical energy coupling means comprises a light coupling section.

45. The device of claim 39, wherein said turning means comprises a light turning section configured to redirect at least a portion of the light received from said light coupling means out of said light guiding means.

46. The device of claim 39, wherein said light guiding means comprises a light guide.

47. A method of manufacturing an illumination device, said method comprising:

forming a substantially planar light guide having a front surface and a back surface that define the front surfaces and back surfaces of a light coupling section and a light turning section disposed adjacently in said light guide, said light coupling section configured to receive optical energy from a light source through said front or back surface at an angle substantially normal to the optical energy receiving front or back surface and propagate the light through the light guide to said light turning section, and wherein said light turning section is configured to direct light from light coupling section out of said light guide.

48. The method of claim 47, wherein said light turning section is configured to direct light out of said light guide through said back surface.

49. A device fabricated by the method of claim 47.

50. A method of illuminating an array of interferometric modulators positioned behind a light guide so that the light guide is between light modulating surfaces of said array and ambient light, the method comprising:

receiving optical energy on a back surface of a substantially planar light guide, wherein at least a portion of the optical energy is received from a direction about normal to said back surface;

coupling the received optical energy into the light guide such that at least a portion of the received optical energy propagates through said light guide; and

redirecting light propagating in the light guide towards an array of interferometric modulators positioned parallel and adjacent to said back surface.

51. The method of claim 50, further comprising providing optical energy on a portion of said back surface, wherein at least a portion of said optical energy is provided in a direction about normal to said back surface.

52. The method of claim 51, wherein coupling the received optical energy comprises diffracting at least a portion of the received optical energy such that received optical energy enters and propagates through the light guide.

53. The method of claim 51, wherein diffracting at least a portion of the received optical energy is performed using a diffractive optical element.

54. The method of claim 53, wherein said diffractive optical element comprises a diffraction grating.

55. The method of claim 53, wherein said diffractive optical element comprises surface diffractive features.

56. The method of claim 53, wherein said diffractive optical element comprises volume diffractive features.

57. The method of claim 53, wherein said diffractive optical element is contained within said light guide.

58. The method of claim 53, wherein said diffractive optical element is disposed on said front surface.

59. The method of claim 53, wherein said diffractive optical element is disposed on said back surface.

60. The method of claim 53, wherein said diffractive optical element is disposed on the optical energy receiving surface of said light guide.

61. The method of claim 54, wherein said diffraction grating is a transmissive diffraction grating.

62. The method of claim 54, wherein said diffraction grating is a reflective diffraction grating.

63. The method of claim 52, wherein said coupling comprises providing at least a portion of the received optical energy to light emissive material having a metal surface disposed adjacent to said light emissive material, said light emissive material and said metal surface

configured such that surface plasmon excitation occurs in said metal surface when said light emissive material is illuminated with said optical energy.

64. The method of claim 52, wherein said light guide comprises photoluminescent material, and coupling comprises providing at least a portion of the received optical energy to said photoluminescent material.

65. The method of claim 64, further comprising redirecting a portion of light emitted by said photoluminescent material that is emitted from said light guide back into said light guide.

66. The method of claim 65, wherein said received optical energy comprises UV light.

67. The method of claim 65, wherein said light is redirected with a reflector.

68. A method of manufacturing a master mold of an illumination device comprising:
providing a crystalline substrate;
forming a first mask on the substrate, the first mask having openings about every $10^4 - 10^6$ nm;
performing an anisotropic wet etch of said substrate through said first mask;
forming a second mask on the substrate, the second mask having openings about every $10^2 - 10^3$ nm;
performing an anisotropic dry etch of said substrate through said second mask;
and
removing the first and second masks.

69. The method of claim 68, the silicon substrate having at least two sections, forming the first mask on a first section and the second mask on the second section.

70. The method of claim 68, further comprising using the etched substrate to form a negative replica of the etched substrate.

71. The method of claim 70, wherein the negative replica comprises an electroformed metal foil.

72. The method of claim 69, further comprising using the etched substrate to form a first negative replica of the first section and form a separate second negative replica of the second section.

73. The method of claim 72, wherein the first negative replica and the second negative replica comprise metal foil.

74. The method of claim 73, wherein the first negative replica and the second negative replica are joined to form a single negative replica.

75. The method of claim 74, wherein the single negative replica is replicated twice to form the master mold such that the first replication produces a similar but inverted surface structure, and the second replication produces the original surface.

76. The method of claim 68, where the periodicity of the openings of the second mask are consistent.

77. The method of claim 68, wherein performing an anisotropic dry etch comprises reactive ion etching using CF_4 gas at low pressure.

78. The method of claim 68, wherein the second mask comprises an organic mask, and removing the second mask comprises using O_2 -plasma.

79. The method of claim 68, wherein the second mask comprises an SiO_2 mask, and removing the second mask comprises using HF wet etching.

80. The method of claim 68, where the periodicity of the openings of the first mask are consistent.

81. The method of claim 68, wherein the silicon substrate has two sections, and the first mask is formed on a first section of the silicon substrate and the second mask is formed on a second section of the silicon substrate, and wherein the periodicity of the openings of the first mask decreases as a function of distance from the first section.

82. An illumination device comprising:

a light guide comprising

a front surface;

a back surface;

a light coupling section comprising light emitting material, said coupling section configured to receive optical energy from a light source in to the light guide through said front surface or said back surface at an angle about normal to the optical energy receiving surface, and further configured to direct light through said light guide; and

a light turning section configured to redirect out of the light guide at least a portion of the light received from said light coupling section, said redirected light at an angle about normal to the optical energy receiving surface.

83. The device of claim 82, wherein said light emitting material comprises photoluminescent material.

84. The device of claim 82, wherein said light emitting material comprises phosphor.

85. The device of claim 82, wherein said light emitting material comprises organic light emitting dyes.

86. The device of claim 82, wherein said light emitting material comprises inorganic quantum dots.

87. The device of claim 82, wherein said light emitting material is disposed within the light coupling section of the light guide.

88. The device of claim 82, wherein said light emitting material is disposed on a surface of the light coupling section.

89. The device of claim 88, wherein the surface the light emitting material is disposed on comprises the front surface of the light guide.

90. The device of claim 82, further comprising a reflector placed adjacent to the light emitting material to reflect light emitted from the light emitting material into the light guide.

91. The device of claim 90, wherein said reflector comprises reflecting tape.

92. The device of claim 90, wherein said reflector comprises at least one metallic film.

93. The device of claim 90, wherein said reflector is a specular reflector.

94. The device of claim 90, wherein said reflector is a diffuse reflector.

95. The device of claim 94, wherein said reflective material comprises white paint.

96. The device of claim 82, wherein said light emitting material is selected to match the emitted light spectrum from the light source.

97. The device of claim 82, wherein said light emitting material comprises a light diffusing material.

98. The device of claim 82, wherein said light emitting material comprises a light scattering material.

99. The device of claim 82, wherein said light emitting material comprises particles capable of both light emission and light scattering.

100. The device of claim 82, wherein the light source is a UV or blue LED and said light emitting material absorbs UV light and re-emits light in substantially all directions.

101. The device of claim 82, wherein the light source comprises a blue LED and the light emitting material comprises photoluminescent material, said blue LED and said light emitting material correspondingly selected to produce white light.

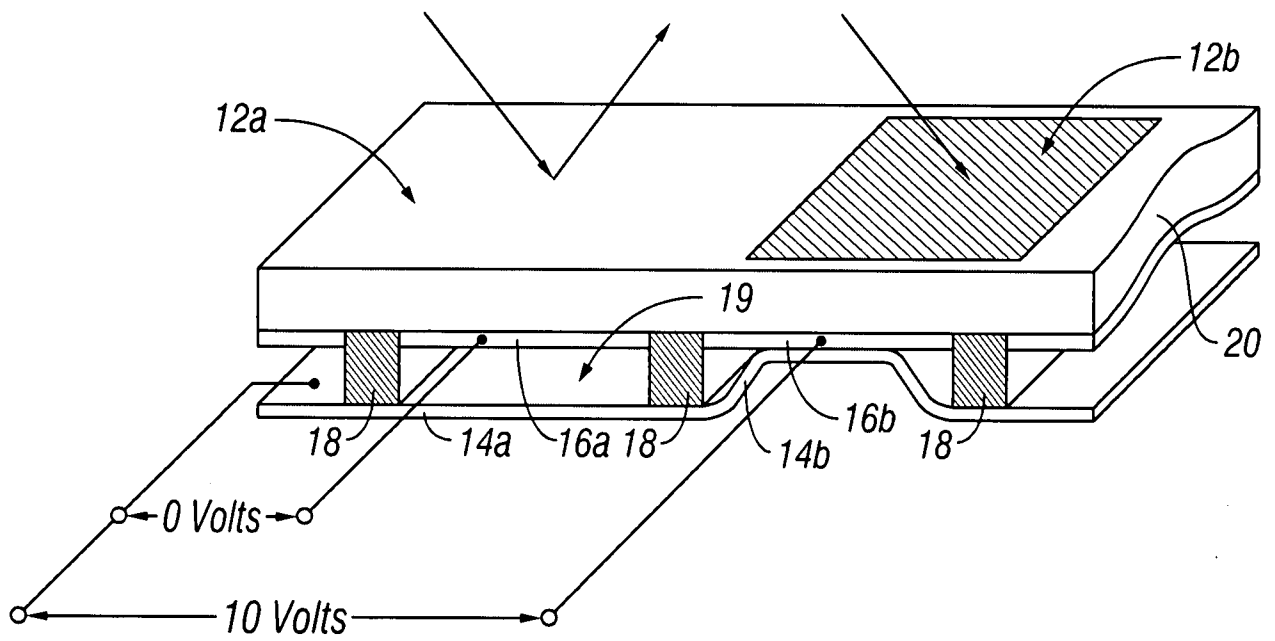

FIG. 1

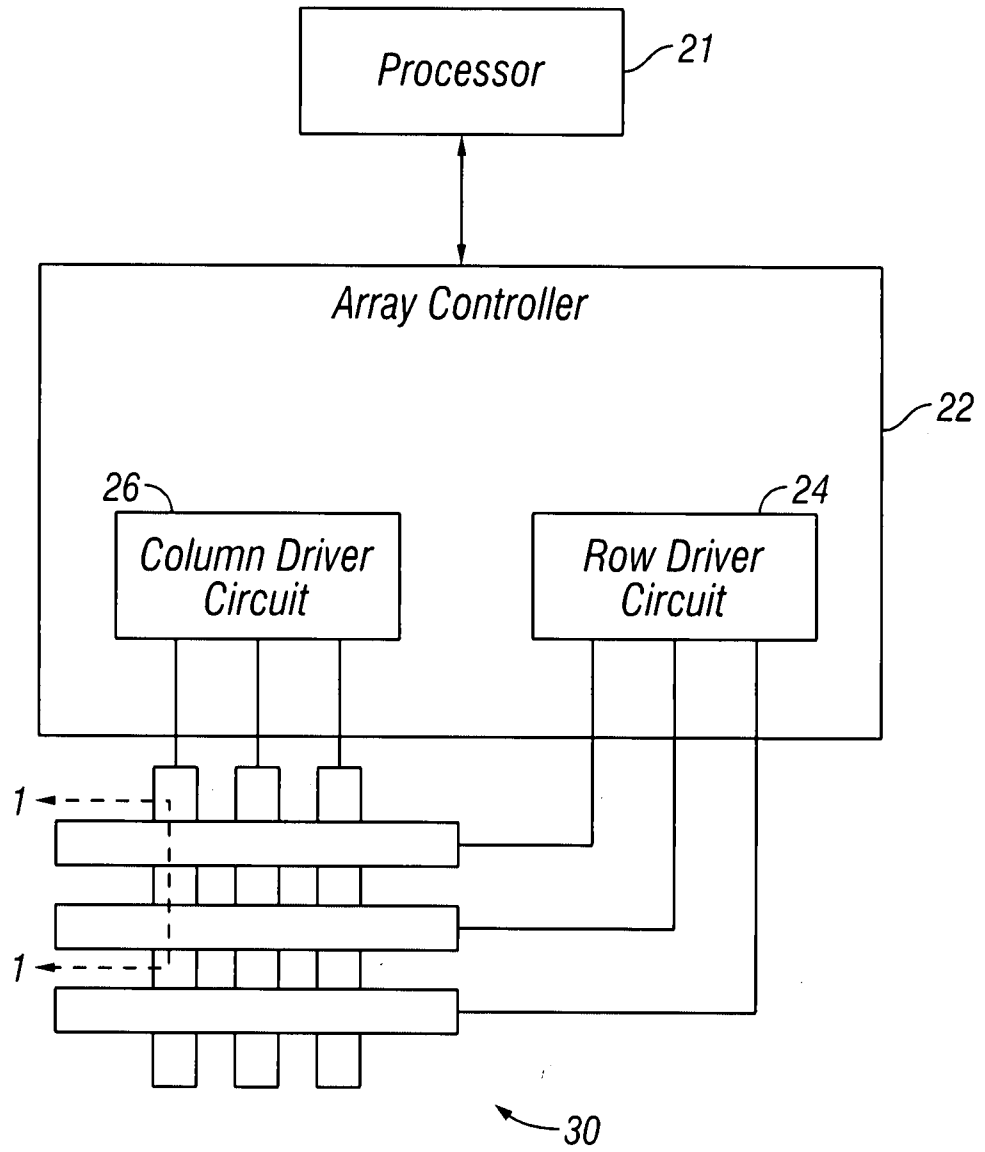

FIG. 2

3/16

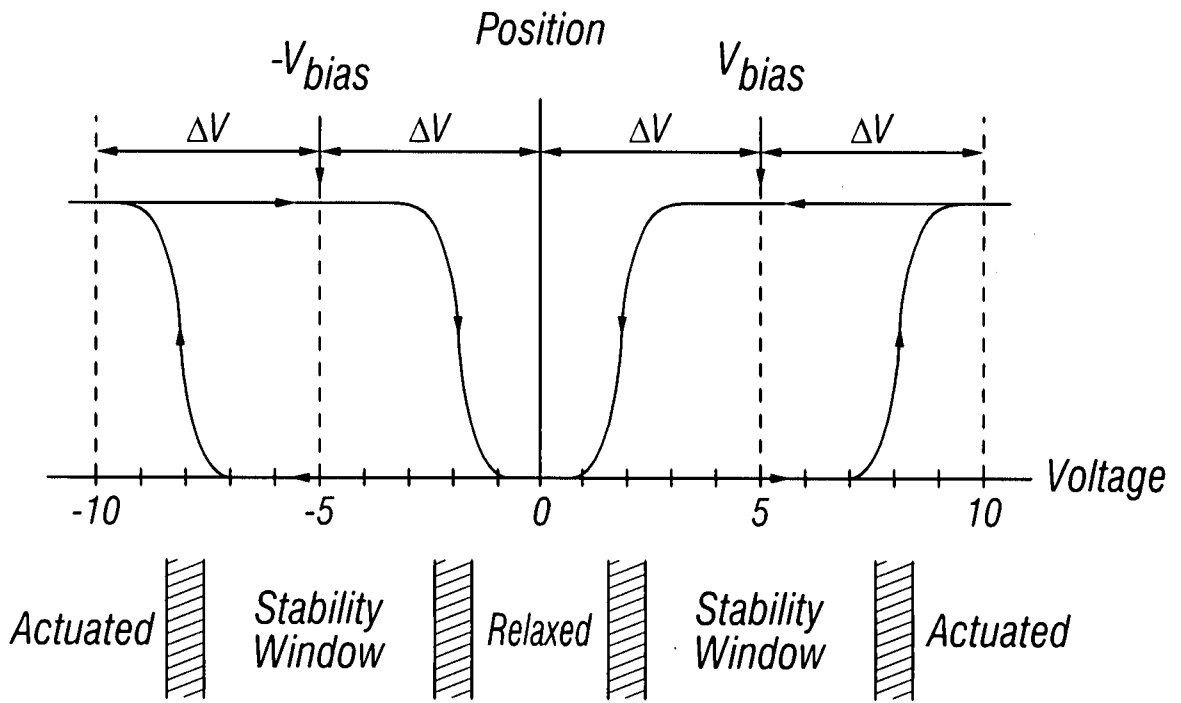

FIG. 3

		Column Output Signals	
		$+V_{bias}$	$-V_{bias}$
Row Output Signals	0	Stable	Stable
	$+\Delta V$	Relax	Actuate
	$-\Delta V$	Actuate	Relax

FIG. 4

4/16

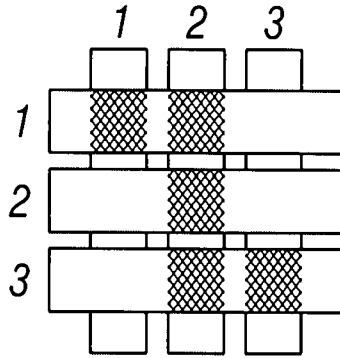

FIG. 5A

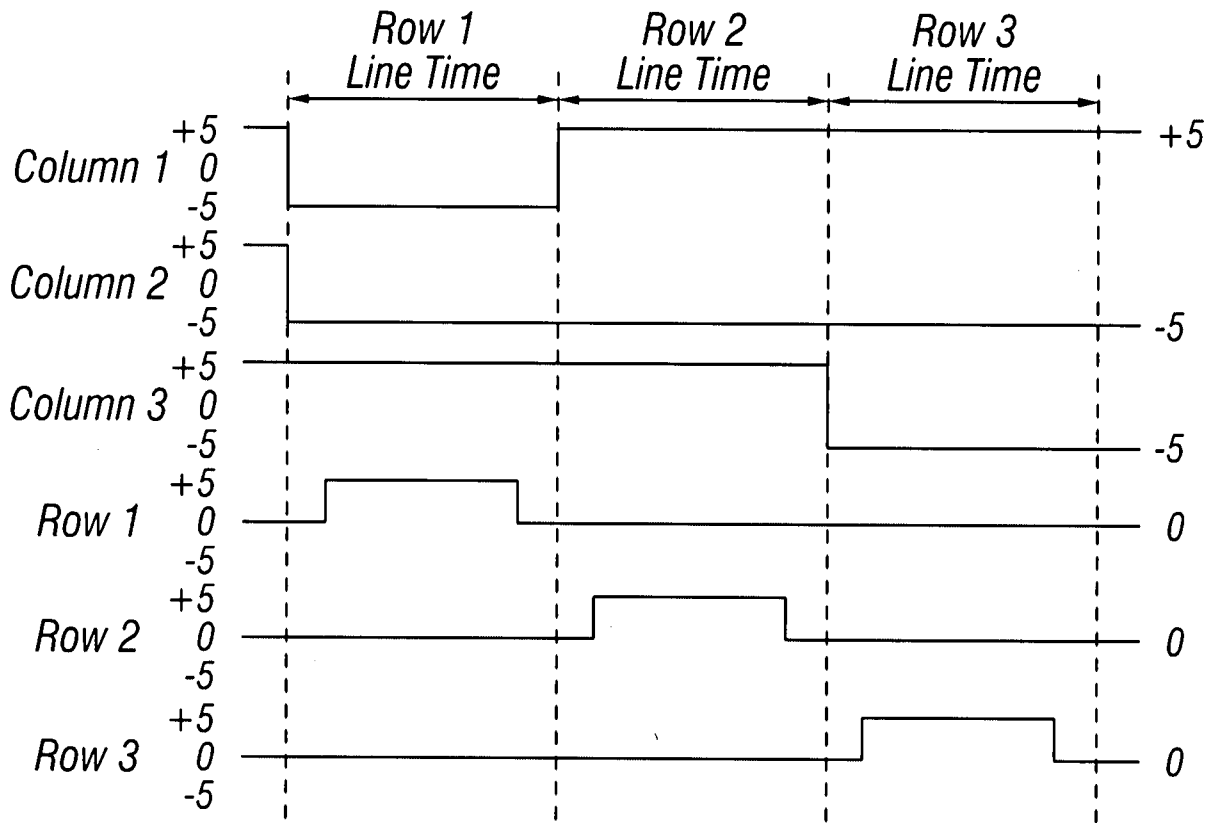

FIG. 5B

40

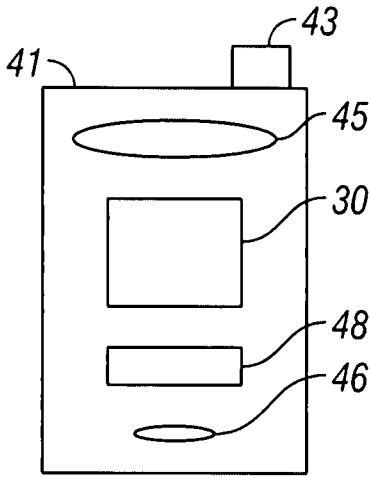

FIG. 6A

40

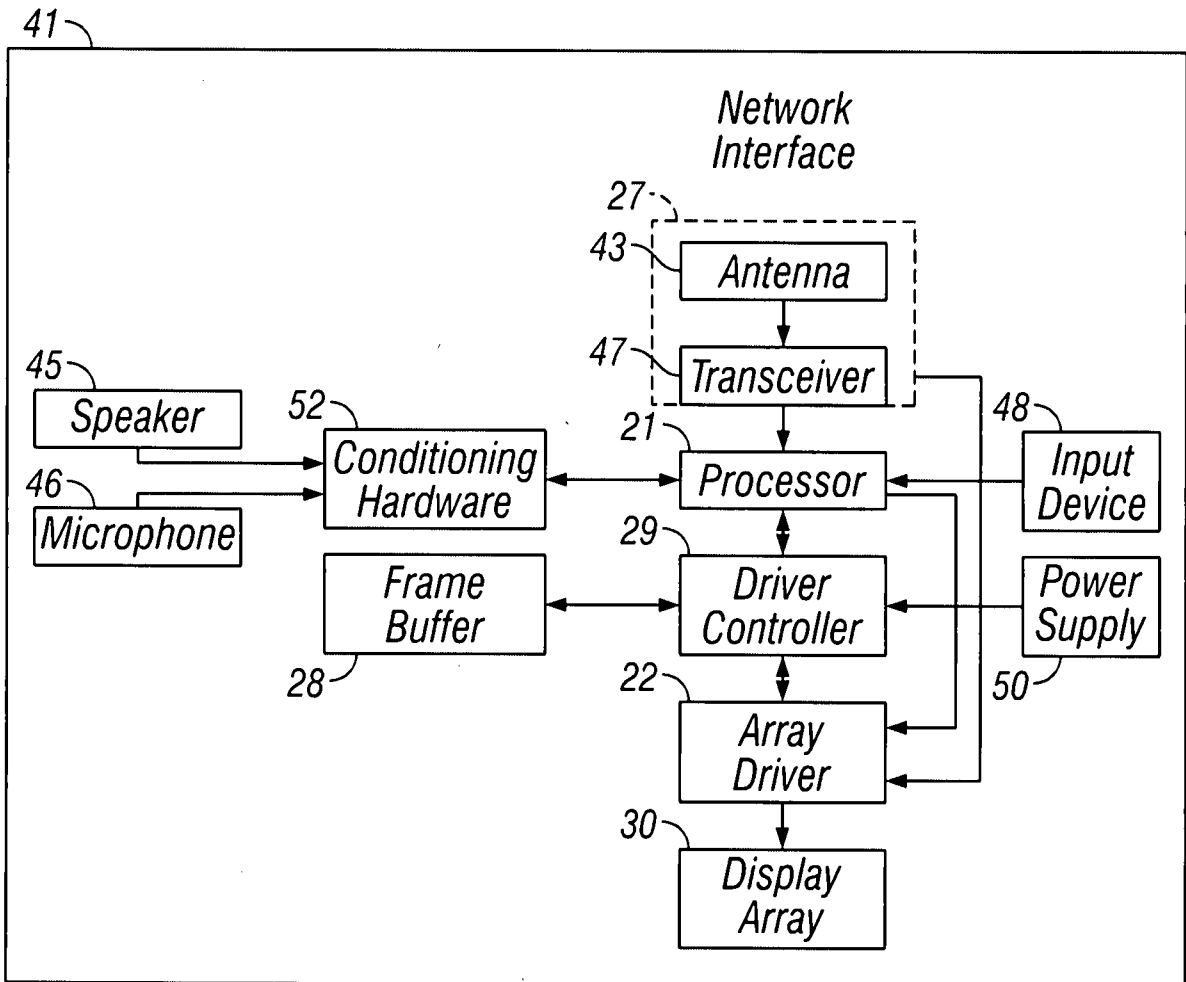

FIG. 6B

6/16

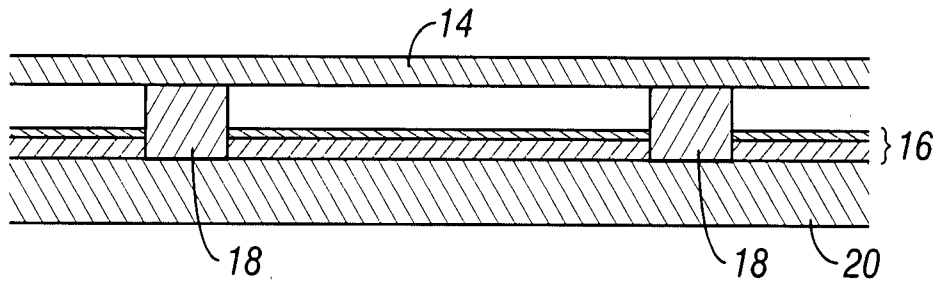

FIG. 7A

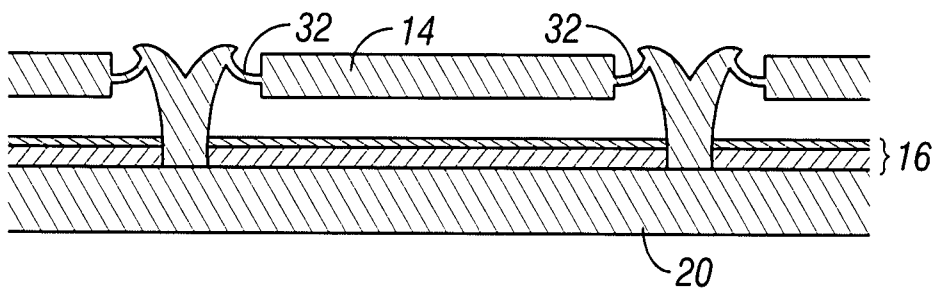

FIG. 7B

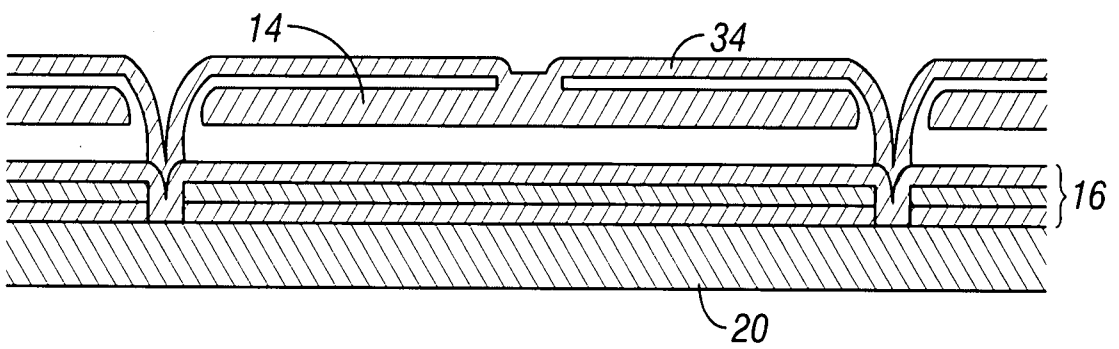

FIG. 7C

7/16

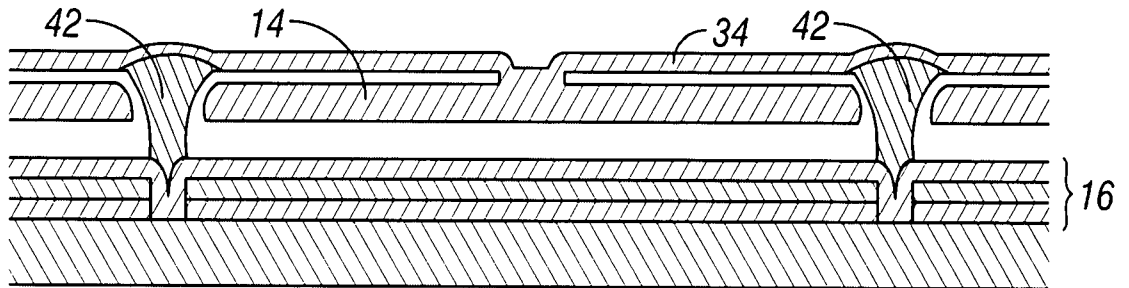

FIG. 7D

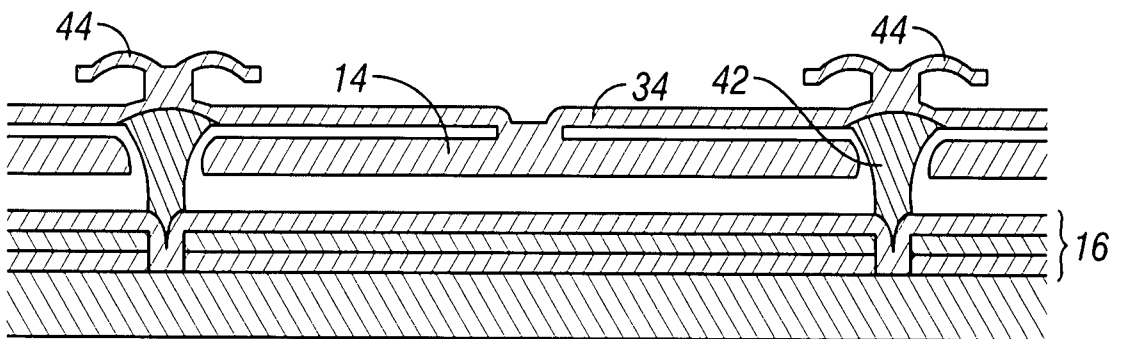

FIG. 7E

8/16

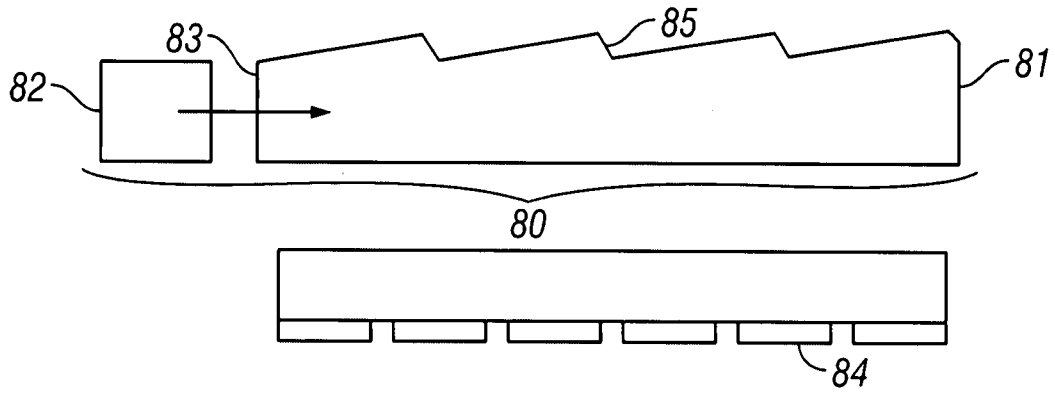

FIG. 8

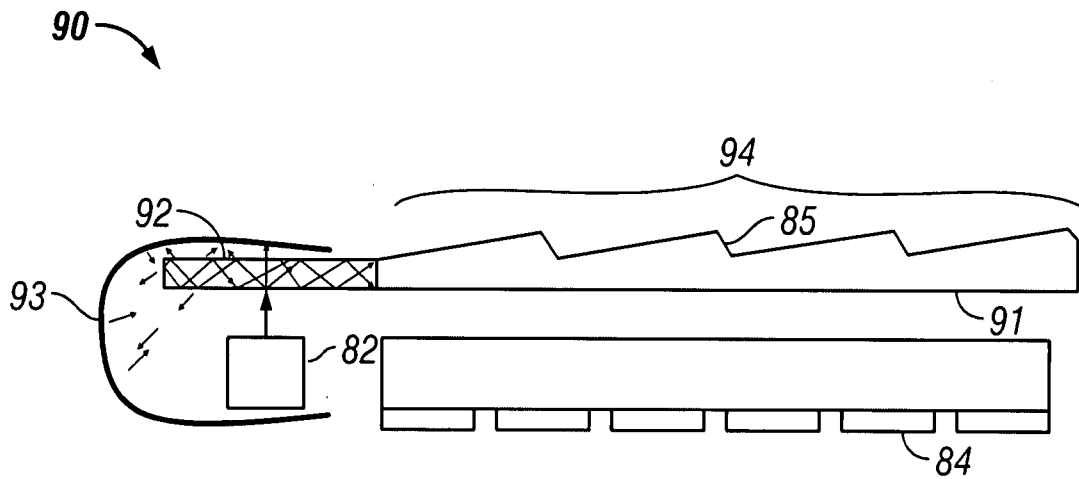

FIG. 9A

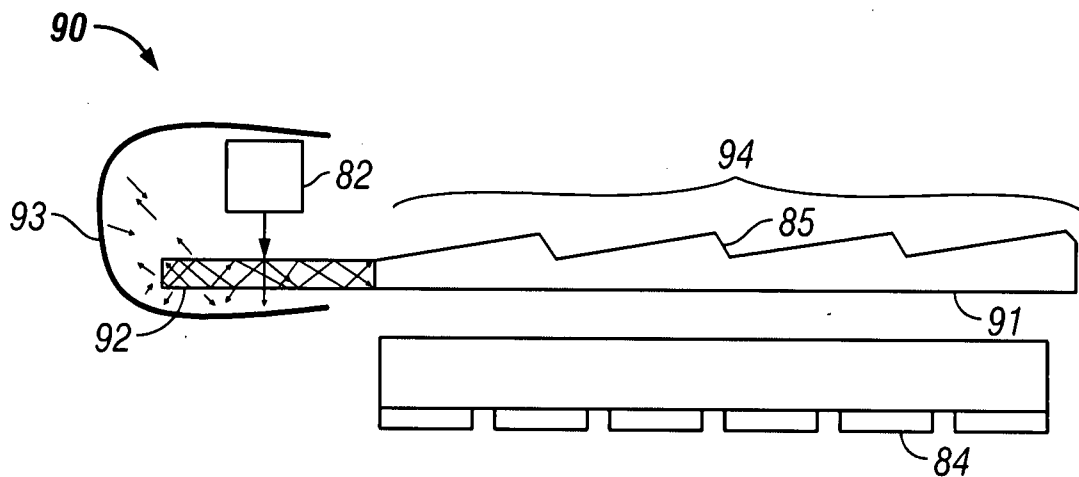

FIG. 9B

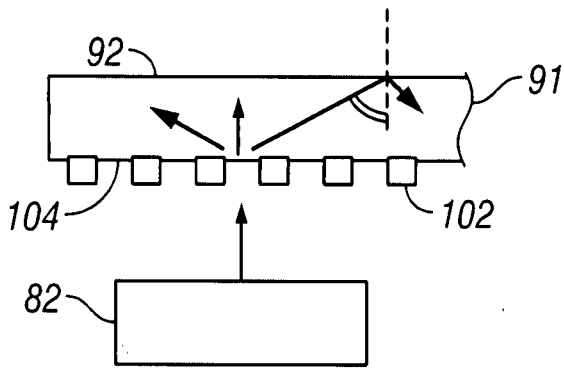

FIG. 10

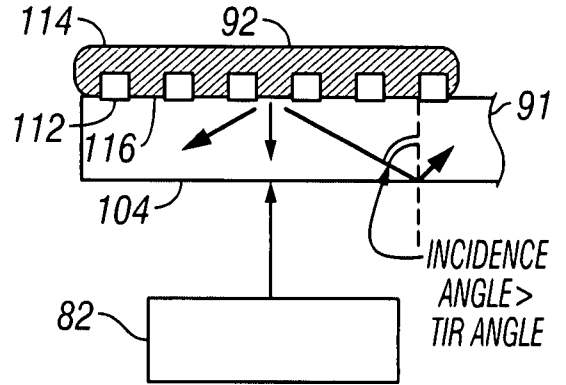

FIG. 11

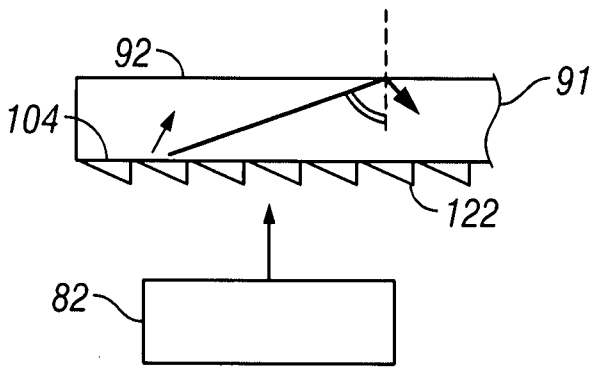

FIG. 12

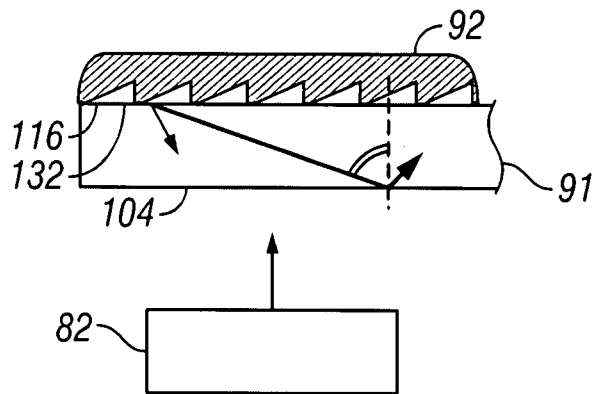

FIG. 13

10/16

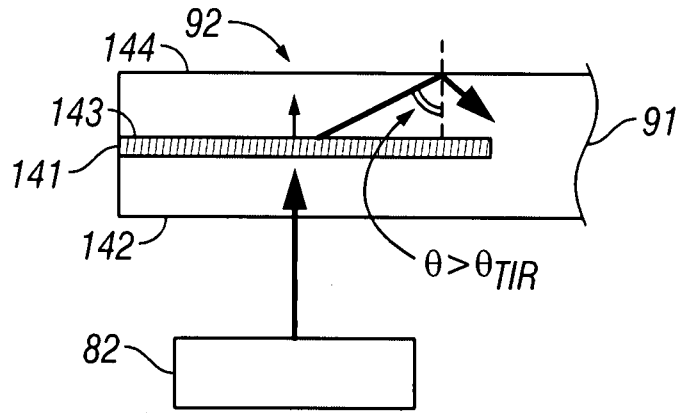

FIG. 14

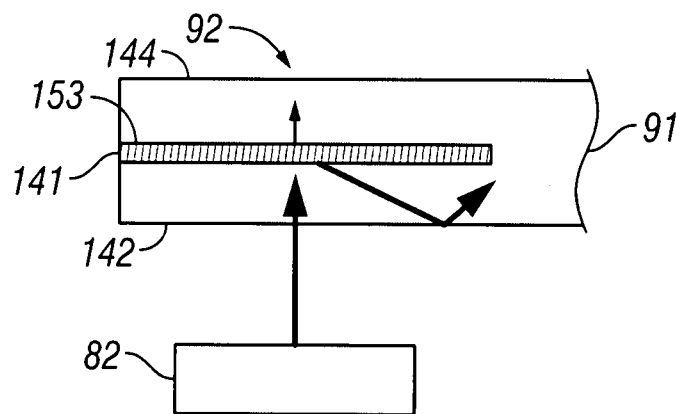

FIG. 15

11/16

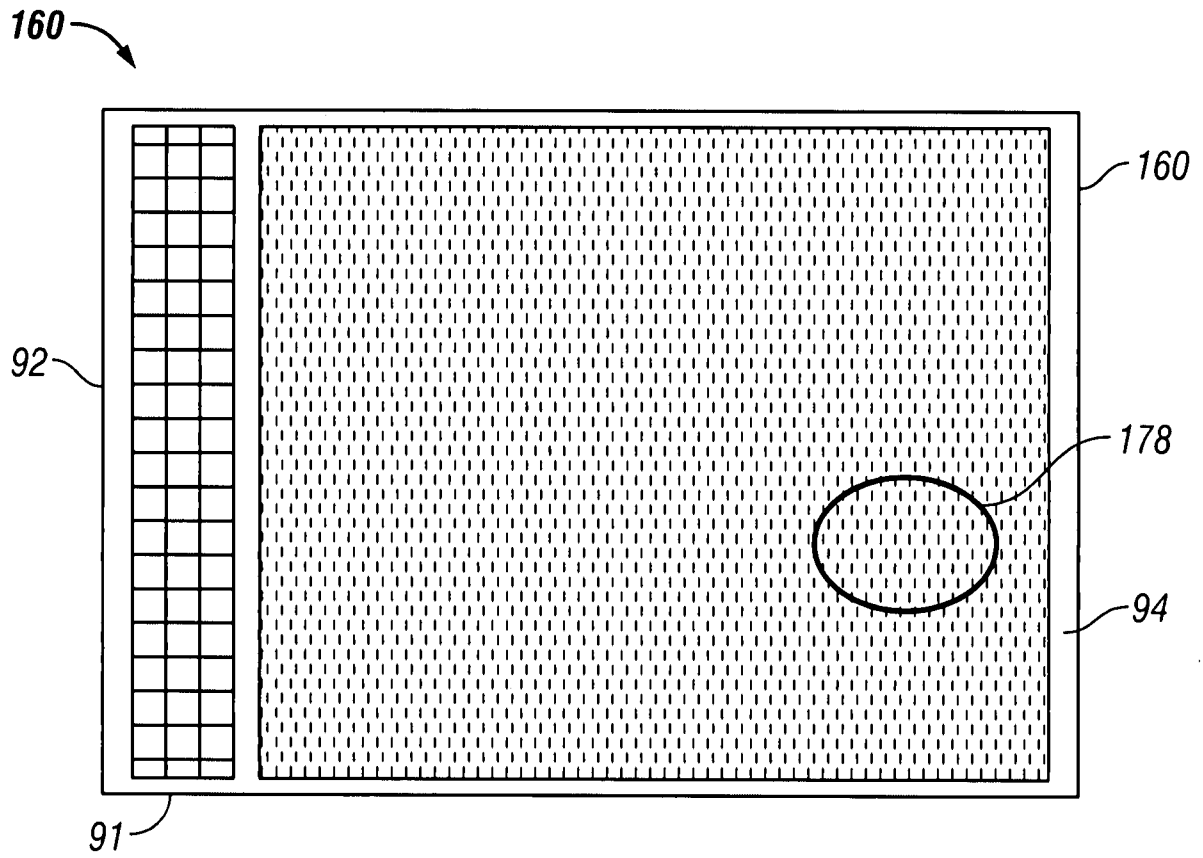

FIG. 16A

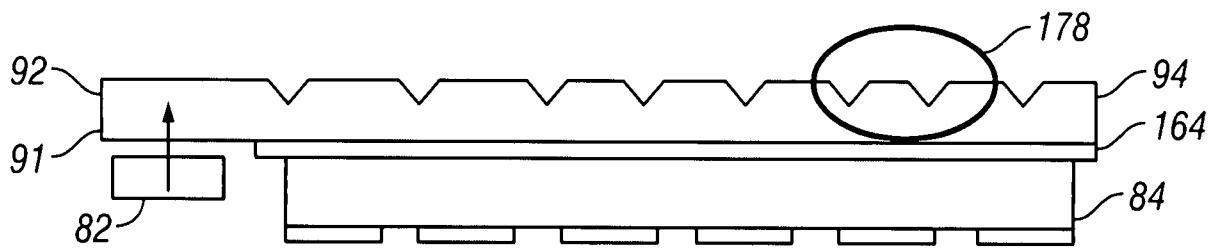

FIG. 16B

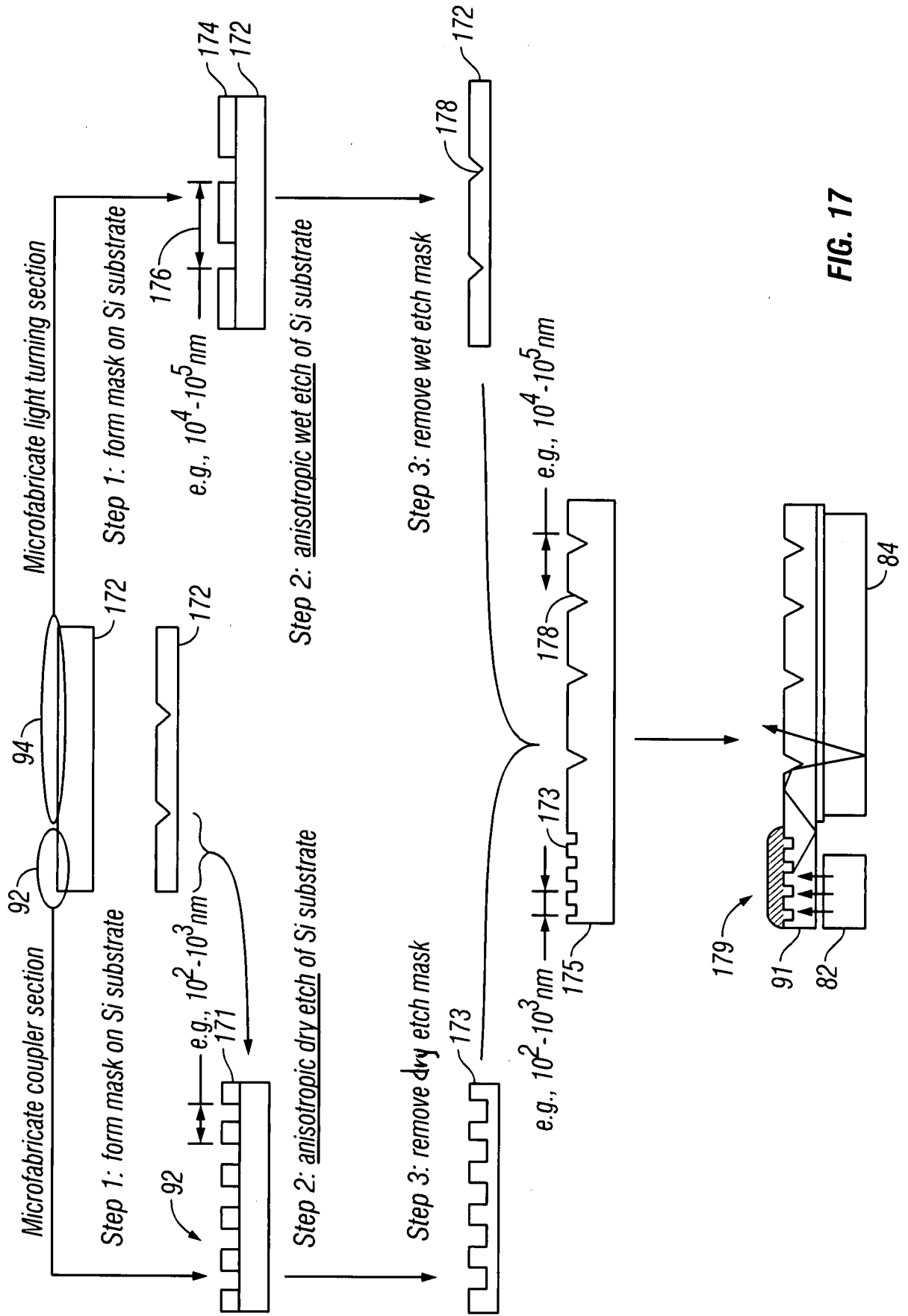

FIG. 17

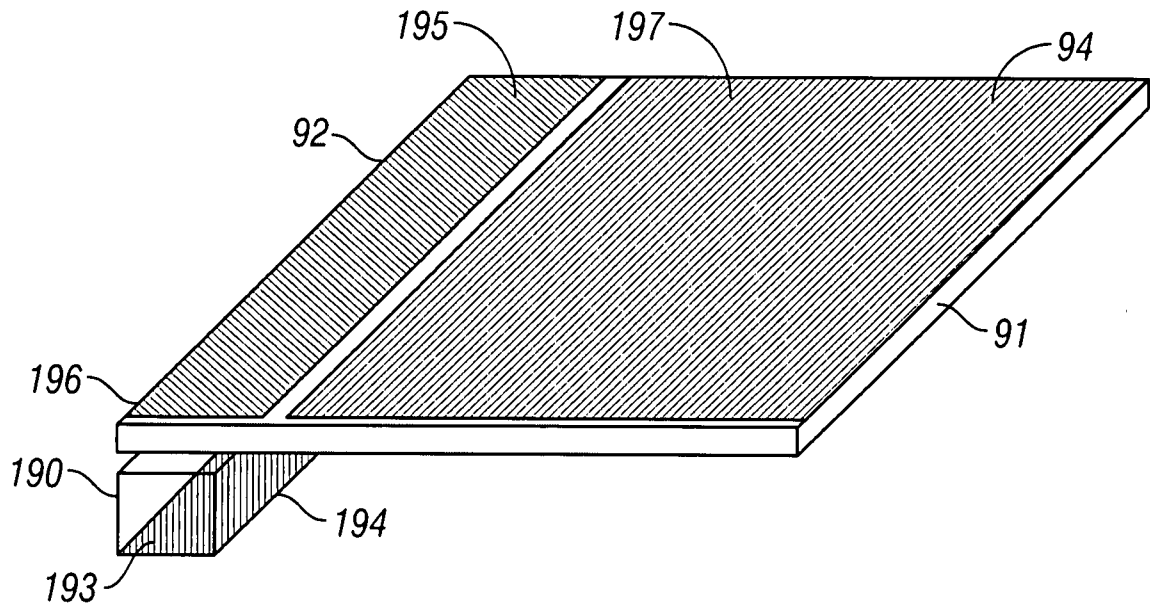

FIG. 19A

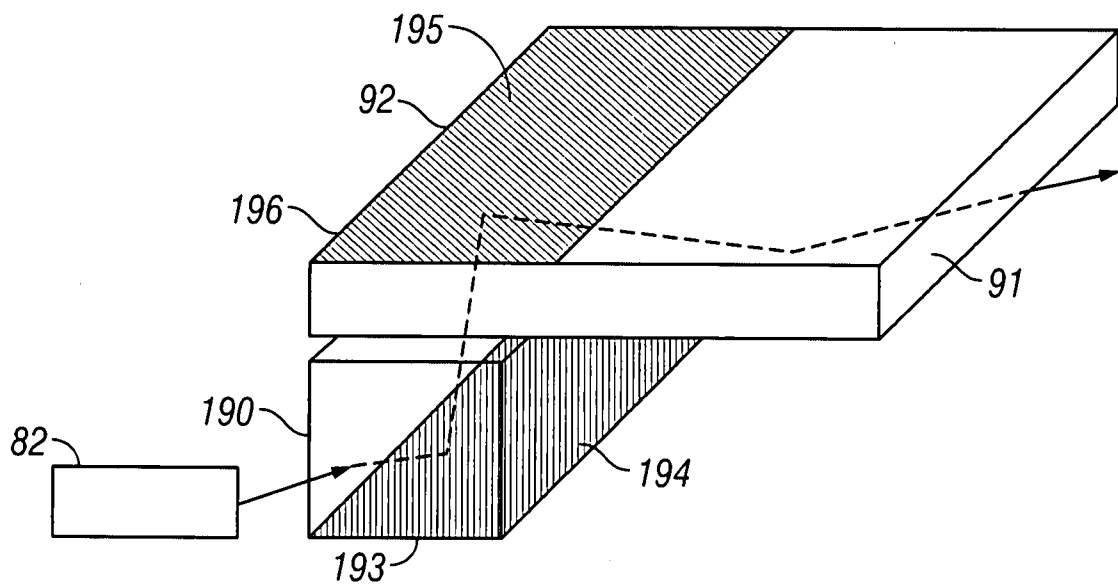

FIG. 19B

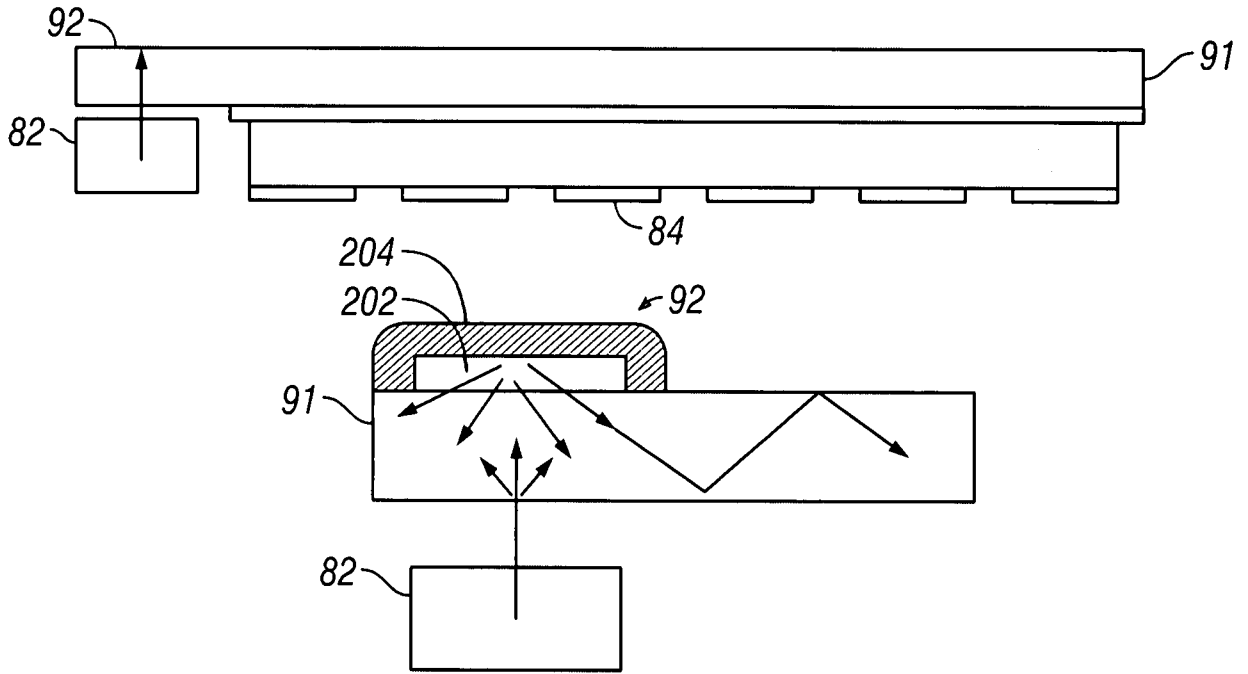

FIG. 20

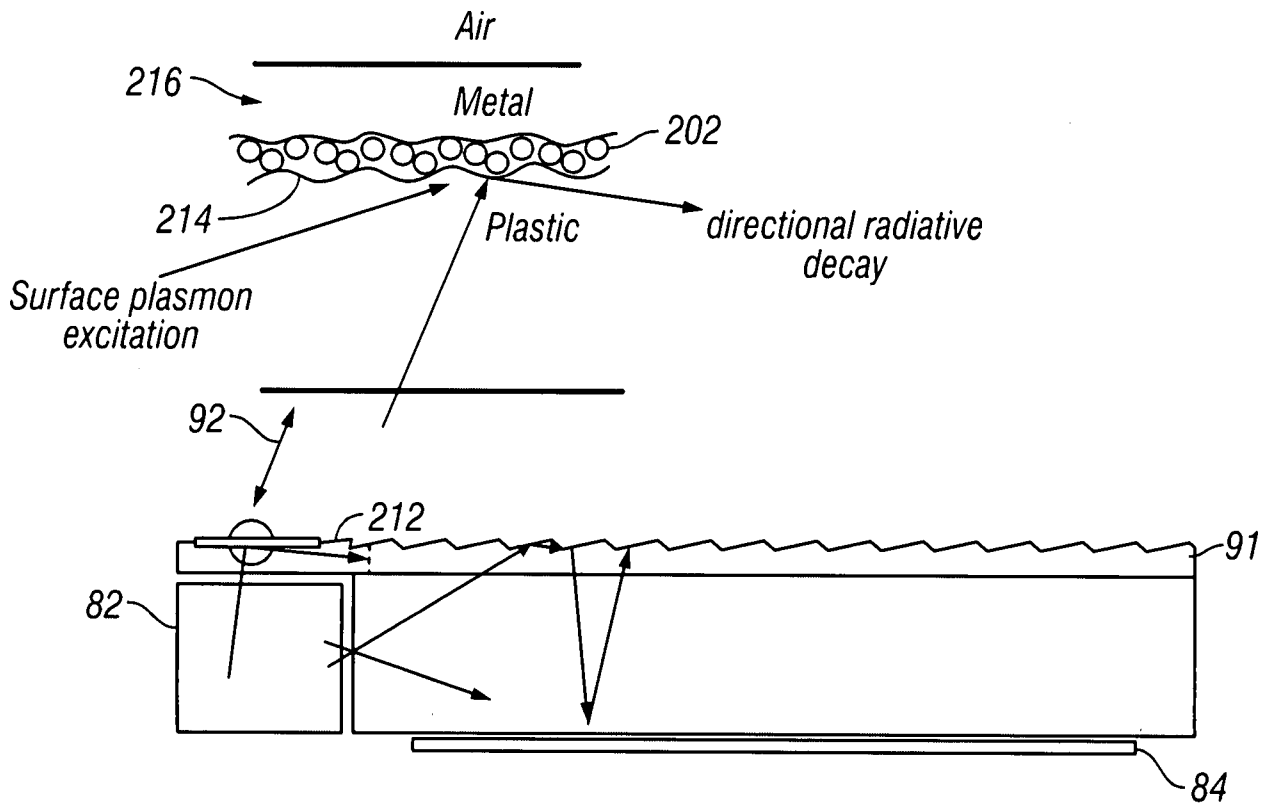

FIG. 21

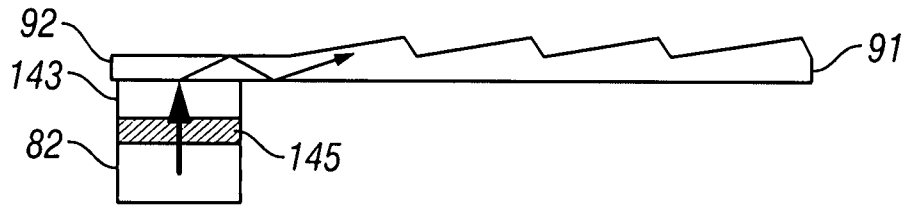

FIG. 22

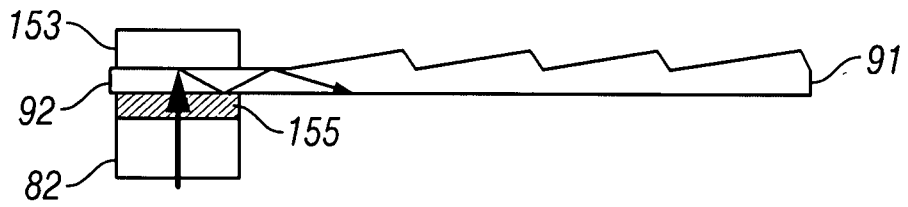

FIG. 23