

(12) STANDARD PATENT
(19) AUSTRALIAN PATENT OFFICE

(11) Application No. **AU 2010202037 B2**

(54) Title
Toothbrushes

(51) International Patent Classification(s)
A46B 15/00 (2006.01) **A61C 17/22** (2006.01)

(21) Application No: **2010202037** (22) Date of Filing: **2010.05.19**

(43) Publication Date: **2010.06.10**

(43) Publication Journal Date: **2010.06.10**

(44) Accepted Journal Date: **2011.12.08**

(62) Divisional of:
2004210643

(71) Applicant(s)
The Gillette Company

(72) Inventor(s)
Chenvainu, Alexander T.; Braun, Phillip M.; Christman, Thomas A.; Brown Jr., William R.

(74) Agent / Attorney
Spruson & Ferguson, Level 35 St Martins Tower 31 Market Street, Sydney, NSW, 2000

(56) Related Art
US 5584690 A
US 6146140 A
US 6513182 A
US 4929180 A

TOOTHBRUSHES

Abstract

A toothbrush head (12) includes a support member (16), a resilient member (20)
5 extending from the support member (16), and a plurality of tufts of bristles (18) extending
from the support member (16) and at least partially surrounding the resilient member
(20). The resilient member (20) may be cup-shaped, fan-shaped, or textured.

2010202037 19 May 2010

AUSTRALIA

PATENTS ACT 1990

COMPLETE SPECIFICATION

FOR A STANDARD PATENT

Name and Address of Applicant :	The Gillette Company, of Prudential Tower Building, Boston, Massachusetts, 02199-8004, United States of America
Actual Inventor(s):	Alexander T. Chenvainu Phillip M Braun Thomas A Christman William R Brown Jr
Address for Service:	Spruson & Ferguson St Martins Tower Level 35 31 Market Street Sydney NSW 2000 (CCN 3710000177)
Invention Title:	Toothbrushes

The following statement is a full description of this invention, including the best method of performing it known to me/us:

TOOTHBRUSHES

This invention relates to toothbrushes, and more particularly to power toothbrushes.

Power toothbrushes are well known and have been on the market for years. In typical power toothbrushes, tufts of bristles on the brush head extend generally perpendicularly from the top surface of the head. The head is oscillated, rotated and/or translated in order to provide enhanced tooth cleaning capability.

Summary of the Invention

The present invention provides a head for a toothbrush comprising:
a support member configured for releasable attachment to a power toothbrush handle;
a cup-shaped resilient member extending from the support member, the cup-shaped resilient member including a plurality of fin members extending inwardly from an inner surface of the cup-shaped member; and
a plurality of tufts of bristles extending from the support member and at least partially surrounding the resilient member, at least some of the tufts of bristles being taller than the cup-shaped resilient member.

Preferably, the cup-shaped member includes a side wall that is substantially continuous.

In one embodiment, the cup-shaped member includes a generally cylindrical side wall.

The cup-shaped member can include a generally conical or frustoconical side wall.

In one embodiment, the resilient member includes a wavy edge.

Preferably, the toothbrush head includes one or more inner cup-shaped members disposed concentrically within an open area defined by the resilient member.

Preferably, the fins have different lengths.

Preferably, the fins have different thicknesses.

5 Preferably, the fins have different heights.

Preferably, the cup-shaped resilient member includes a plurality of individual elements extending from a common base.

Preferably, the cup-shaped resilient member includes a molded element having an integrally molded surface texture.

10 Preferably, the cup-shaped resilient member comprises a material having texture-impacting particles embedded in its surface.

By “resilient member” we mean a unitary structure formed of a resilient material such as an elastomer or foam, the resilient member having a perimeter, when the resilient member is viewed from above (e.g., looking down the long axis of the bristles, if the
15 bristles and resilient member are disposed perpendicular to the support member), which circumscribes an area greater than the surface area of the resilient member that will initially contact the teeth of a user of the toothbrush. By “initially contact the teeth”, we mean the surface area that will contact the teeth and/or gums prior to any significant deformation of the resilient member resulting from the application of pressure against the
20 teeth, i.e., the area that would contact the teeth if the toothbrush were lightly touched to the teeth with the power turned off. By “unitary structure”, we mean that, if the resilient member includes a plurality of elements, such as fins, protrusions or lammellae, the elements are integrally joined to form a single structure that is mounted on the separate support member.

The term “cup-shaped”, as used herein, refers to a shape that is generally elliptical, oval, ovoid, or circular in cross-section and that defines a central open area.

The walls of the cup-shaped member may be continuous or discontinuous and may define a cylinder, cone, frustroconical shape, or other desired shape. The bottom of the central
5 open area may be flat, concave, or any other desired shape.

The term “fan-shaped”, as used herein, refers to a shape that is generally comprised of a central hub region and at least two protrusions, e.g., ribs, fins, or other types of protrusions, that extend substantially radially from the central hub region. The protrusions may form a helix, spiral, screw, or other pattern. The central hub region may
10 be solid, hollow, or cup-shaped, and may be, for example, generally elliptical, oval, ovoid, or circular in cross-section.

The term “textured”, as used herein, refers to a structure that has a macroscopic surface texture. For example, the textured member may be composed of a cluster of ribs, fins, columns, or other protrusion, or a combination of ribs, fins, columns, or other
15 protrusions, that together form a unitary structure. As other examples, the texture can be imparted to the member by a manufacturing process such as injection molding, by embedding particles in the surface of the member, or by selecting a material for the member that inherently has a surface texture, e.g., an open cell foam.

Description of Drawings

Preferred embodiments of the present invention will now be described, by way of example only, with reference to the accompanying drawings wherein:

Fig. 1 is a perspective view of a portion of a power toothbrush, according to a first embodiment of the invention.

Fig. 1A is similar to Fig. 1, with the front tufts of bristles removed to show the detail of the cup-shaped member.

Fig. 1B is a side view of Fig. 1A.

Figs. 2 is a perspective view of a toothbrush head according to an alternative embodiment of the invention. Fig. 2A is a side view of a toothbrush head similar to the one shown in Fig. 2 with the front tufts of bristles removed to show the detail of the cup-shaped member. Fig. 2B is a cross-sectional view of the toothbrush head shown in Fig. 2, taken along the long axis of the toothbrush.

Figs. 3-10 are perspective views of toothbrush heads according to various alternative embodiments of the invention, with the exception of Fig. 7A, which shows the toothbrush head shown in Fig. 7 with the front tufts of bristles removed to show the detail of the fan-shaped member.

Referring to Fig. 1, a power toothbrush 10 includes a head 12 and a neck 14. As is well known to those skilled in the art, head 12 is oscillated during brushing. An electric motor (not shown) oscillates the head through gearing, linkages, cranks, and/or other drive mechanisms as is well known. Electrical power may be supplied to the motor by rechargeable or single use (disposable) batteries. Further details as to how the head is oscillated will not be provided, as this aspect of the brush is not the focus of the invention.

Head 12 includes a generally circular support member 16, and, extending from the support member 16, a plurality of bristle tufts 18. Although each tuft is shown as a solid mass in the drawings, the tufts are actually each made up of a great mass of individual plastic bristles. The bristles may be made of any desired polymer, e.g., nylon 6.12 or 6.10, and may have any desired diameter, e.g., 4-8 mil. The tufts are supported at their bases by the support member, and may be held in place by any desired tufting technique as is well known in the art, e.g., hot tufting or a stapling process. The tufts may also be mounted to move on the support member, as is

well known in the toothbrush art.

Head 12 further includes a cup-shaped member 20, which can be seen clearly in Fig. 1A, in which some of the bristle tufts have been omitted. Cup-shaped member 20 includes a side wall 22 that defines a central open area 24. Generally, the central open area 24 has a depth of from about 2 to 5 mm, measured from the highest point of the rim of the cup-shaped member to the lowest point of the central open area. Cup-shaped member 20 also includes a plurality of ribs 26 that extend inwardly into the open area 24. The cup-shaped member 20 is preferably formed of a resilient material such as an elastomer, e.g., a thermoplastic elastomer. The material hardness for such structures may range from 10 to 70 Shore A, with the preferred hardness selection depending on the design and dimensions of the cup-shaped member.

The cup-shaped member 20 may be fixedly mounted on the toothbrush head, or may be rotatably mounted, so that the cup-shaped member 20 can spin about its long axis while the toothbrush head is oscillated. The spinning motion may be driven by the same motor that oscillates the head, as would be understood by those skilled in the art. If the cup-shaped member is fixedly mounted, it may be mounted by any conventional technique, e.g., by screwing it in place or over-molding it onto the support member.

As shown in Fig. 1B, the height of bristle tufts 18 above the top surface S of support member 16 will generally be greater than the height of the cup-shaped member 20 from surface S. This height differential allows the head to contour around each tooth, enhancing the tooth-to-tooth indexing effect mentioned above.

There is also a height differential between the different bristle tufts. The end bristle tufts 18A, i.e., the tufts that are adjacent the long axis of the toothbrush neck 14 when the head 12 is at rest, are taller than the side tufts 18b. For example, the height of the cup-shaped member may be from about 5.5 to 10 mm, with the end tufts 18A being about 20 to 30% taller than the cup-shaped member, e.g., from about 6.6 to 13 mm in height, and the side tufts 18b being about 5 to 15% taller than the cup-shaped member, e.g., about 5.8 to 11.5 mm in height. Making the side tufts shorter than the end tufts allows the longer tufts to reach in between the teeth, while the shorter tufts clean along the gumline.

Toothbrush heads according to other embodiments are shown in Figs. 2-10. In each of these embodiments, the support members 116 are generally elliptical, rather than circular as shown in Fig. 1. The elliptical shape provides more room for additional bristle tufts, and thus these toothbrush heads further include curved, elongated interdental tufts 28. In these embodiments, the cup-shaped member and bristle tufts are generally shorter than in the embodiment discussed above. In an elliptical head, the reduced height will tend to make the brush more comfortable and less "bulky" feeling in a user's mouth. As in the embodiment discussed above, the bristle tufts are generally taller than the cup-shaped member. As shown in Fig. 2A, the interdental tufts 28 are also taller than the cup-shaped member, e.g., by about 30 to 40%.

Each of the embodiments shown in Figs. 2-7 includes a different type of cup-shaped member.

In head 112, shown in Fig. 2, cup shaped member 120 includes a side wall 122, and extending inwardly from the side wall, a plurality of ribs 30 that converge at a generally cylindrical central hub 32. In alternate embodiments (not shown) the central hub may be conical or cup-shaped. In this design, as shown in Fig. 2B, the ribs are at the same height as the cup at the outer perimeter, and decrease in height as they approach the center. This arrangement allows the ribs to act as "squeegees" to clean the tooth surface. The addition of the central hub adds strength to the total structure and the ribs. If this additional strength is not required for a particular design, the central hub may be omitted, and the ribs may simply intersect each other, or may stop short of intersecting. In head 212, shown in Fig. 3, cup-shaped member 220 includes a side wall 222 and, extending inwardly from the side wall, a plurality of larger ribs 34 and smaller ribs 36. The larger ribs are longer (i.e., extend further into the center), and may have a different thickness and/or height than the smaller ribs.

In the embodiments shown in Figs. 4 and 5, the cup-shaped member is segmented, i.e., it has a discontinuous side wall that includes a plurality of arcuate segments. The segmented structure imparts flexibility to the cup-shaped member, and may allow the cup-shaped member to conform better to the tooth surface. As can be seen in Fig. 5, in these embodiments the segments are defined by grooves 42 that do

not extend to the bottom of the cup-shaped member. As a result, the segments are connected to form a unitary structure.

In head 312, shown in Fig. 4, cup-shaped member 320 includes a segmented side wall that includes four arcuate segments 40 having grooves 42 therebetween. Within the open center area defined by the cup-shaped member 320 are disposed two concentrically arranged smaller inner cup-shaped members 44 and 46. These inner cup-shaped members have the same segmented structure as the outer cup-shaped member 320. The concentric members provide a large surface area for contact with the tooth surface, which may provide improved cleaning.

In head 412, shown in Fig. 5, cup-shaped member 420 again includes a segmented side wall comprised of four arcuate segments. In this embodiment, ribs 126 extend inwardly from the side wall, as in the embodiment shown in Fig. 1.

In the embodiment shown in Fig. 6, head 612 includes a cup-shaped member 620 that has a wavy fringe 54 extending above its upper edge 56. The wavy fringe is relatively soft and flexible, so that it will lay flat when pressed against the surface of the teeth. This may allow the fringe to slide under the gums and between the teeth, providing plaque removal and gum stimulation which may reduce gingivitis. Generally, the fringe has a thickness of about 0.15 to 0.25 mm, measured at its top edge, and about 0.4 to 0.8 mm measured at its base (where the fringe joins the rim of the cup-shaped member). While four relatively large waves are shown in Fig. 6, if desired more waves and/or smaller waves may be used. The number and size of the waves are selected to provide desired product attributes.

Head 612 also differs from the designs described above in that the cup-shaped member 620 includes ribs 60 that are inclined with respect to the longitudinal axis of the cup-shaped member.

In the embodiment shown in Fig. 7, head 512 includes a fan-shaped member 520 that has a plurality of ribs 50 extending radially from an outer surface of its side wall 52 in a fan-like arrangement. In this embodiment, the side wall 52 is generally conical. Alternatively, if desired, the side wall may be cylindrical (not shown). In this embodiment, the fan-like structure of the cup-shaped member may enhance the foaming action of some toothpastes. The ribs may also act as "squeegees",

enhancing tooth-cleaning action.

In the embodiment shown in Fig. 8, head 712 includes a textured member 720 that is comprised of a plurality of lammellae 722 that extend from a common base 724 together define a unitary structure. The lammellae 722 are arranged in different directions to give a "textured" feel. In this embodiment, the lammellae define a generally circular member, and are arranged in groups that are at right angles to each other in a "woven" pattern. However, the textured member may have any desired shape and arrangement of lamellae. It is generally preferred that the lammellae be relatively closely spaced, e.g., that spaces 726 be less than about 0.75 mm wide, more preferably about 0.5 mm or less.

In the embodiment shown in Fig. 9, head 812 includes a textured member 820. Textured member 820 includes a generally cylindrical base 822 and, extending from the base, a contact portion 824 that includes a central hub 826 and a plurality of ribs 828 extending radially from the hub. Textured member 820 may be formed of a foam, as shown, to provide a surface texture.

In the embodiment shown in Fig. 10, head 912 includes a textured member 920, including a generally cylindrical base 922 and, extending from the base, a plurality of small nubs 924 that provide the member with a textured feel.

A textured feel may be provided in many ways, for example by forming a resilient member of any desired shape of a material having a macroscopic surface texture, e.g., an open celled foam, or a material having texture-imparting particles embedded in its surface.

Other embodiments are within the scope of the following claims.

For example, while the cup-shaped member is shown in the drawings as centrally-located on the toothbrush head, if desired it may be positioned off-center.

Moreover, while various embodiments are shown in the drawings and described above, many other types of cup-shaped members may be used, as will be well understood by those skilled in the art. For example, the side wall of the cup-shaped member may have a tapered outer surface, or may be straight sided or have any other desired design.

Additionally, which the cup-shaped member is described above as

being surrounded on all sides by bristle tufts, if desired the cup-shaped member may be only partially surrounded by bristle tufts. For example, if desired the side tufts 18B in Figs. 1 could be omitted.

Moreover, while heads for power toothbrushes have been described
5 above, resilient members having the features described above may be used on manual toothbrushes, if desired.

The claims defining the invention are as follows:

1. A head for a toothbrush comprising:
5 a support member configured for releasable attachment to a power toothbrush handle;
a cup-shaped resilient member extending from the support member, the cup-shaped resilient member including a plurality of fin members extending inwardly from an inner surface of the cup-shaped member; and
10 a plurality of tufts of bristles extending from the support member and at least partially surrounding the resilient member, at least some of the tufts of bristles being taller than the cup-shaped resilient member.
2. The toothbrush head of claim 1, wherein the cup-shaped member includes a side wall that is substantially continuous.
- 15 3. The toothbrush head of claim 1 or 2, wherein the cup-shaped member includes a generally cylindrical side wall.
4. The toothbrush head of any one of claims 1 to 3, wherein the cup-shaped member includes a generally conical or frustoconical side wall.
5. The toothbrush head of any one of claims 1 to 4, wherein the resilient
20 member includes a wavy edge.
6. The toothbrush head of any one of claims 1 to 5, further including one or more inner cup-shaped members disposed concentrically within an open area defined by the resilient member.
7. The toothbrush head of any one of claims 1 to 6, wherein the fins have
25 different lengths.
8. The toothbrush head of any one of claims 1 to 7, wherein the fins have different thicknesses.
9. The toothbrush head of any one of claims 1 to 8, wherein the fins have different heights.
- 30 10. The toothbrush head of any one of claims 1 to 9, wherein the cup-shaped resilient member includes a plurality of individual elements extending from a common base.
11. The toothbrush head of any one of claims 1 to 10, wherein the cup-shaped resilient member includes a molded element having an integrally molded surface
35 texture.

12. The toothbrush head of any one of claims 1 to 11, wherein the cup-shaped resilient member comprises a material having texture-imparting particles embedded in its surface.

5 13. A head for a toothbrush substantially as hereinbefore described with reference to the accompanying drawings.

Dated 19 May 2010

The Gillette Company

10 **Patent Attorneys for the Applicant/Nominated Person**

SPRUSON & FERGUSON

2010202037 19 May 2010

1/11

FIG. 1

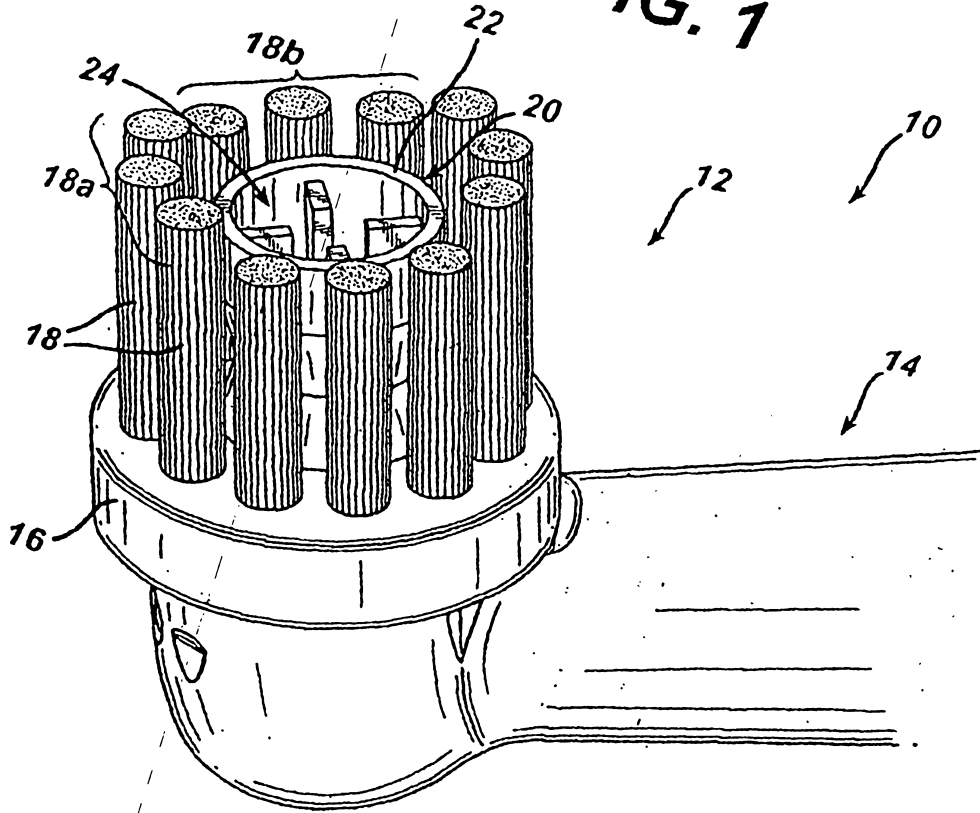

FIG. 1A

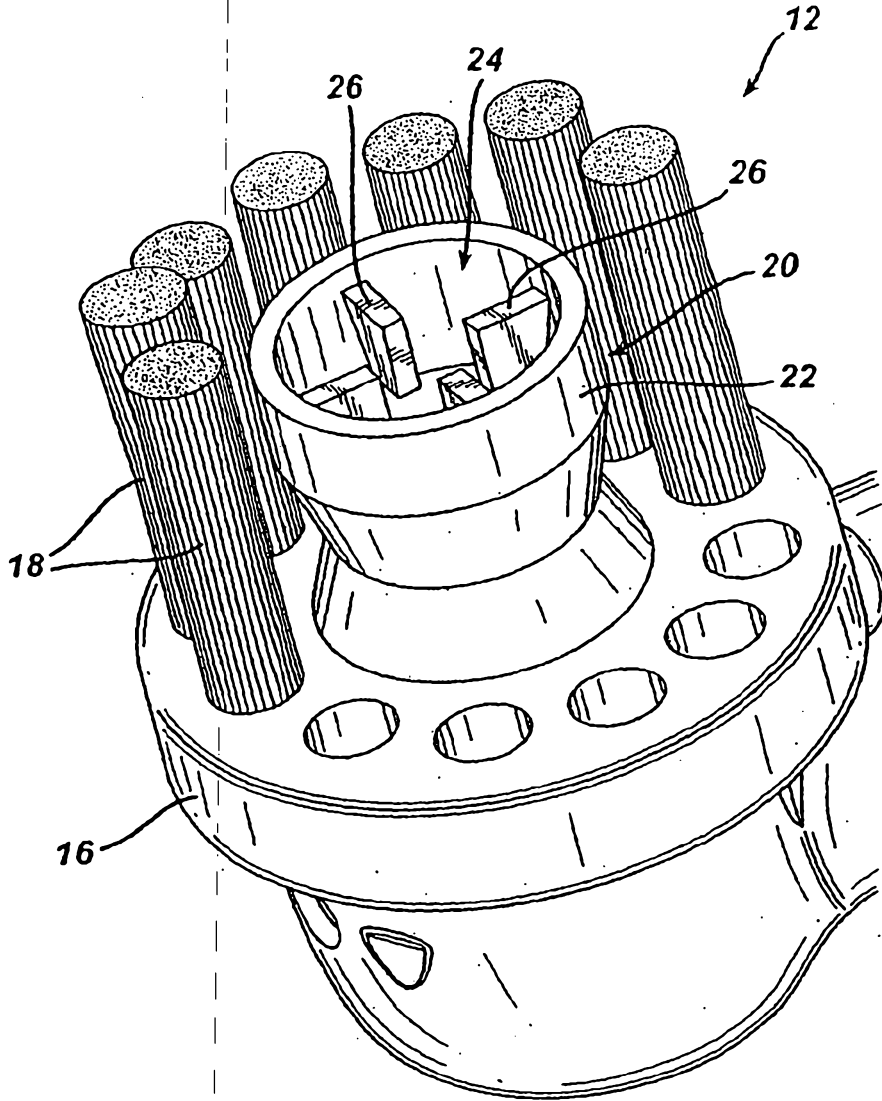

FIG. 1B

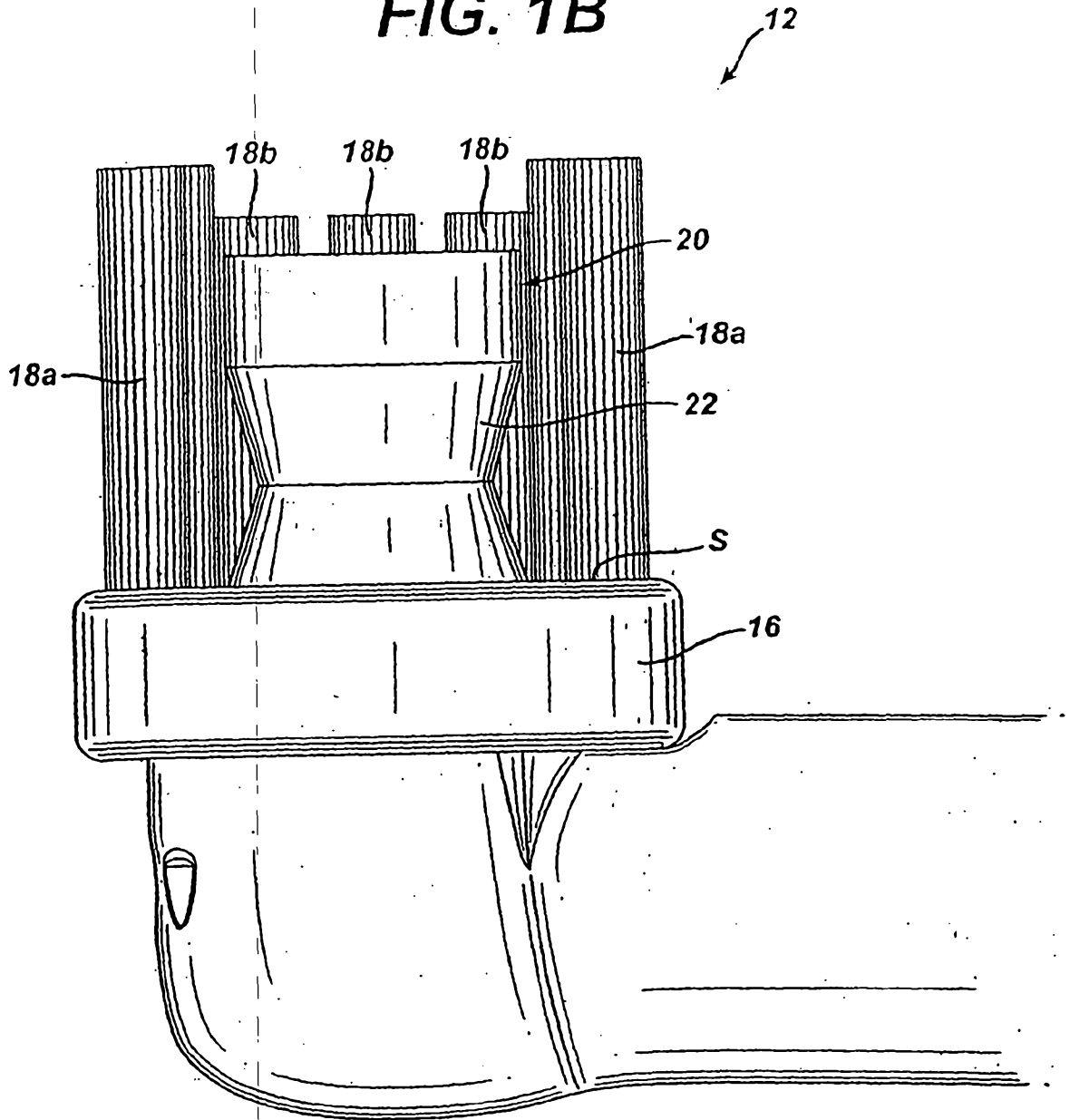

FIG. 2

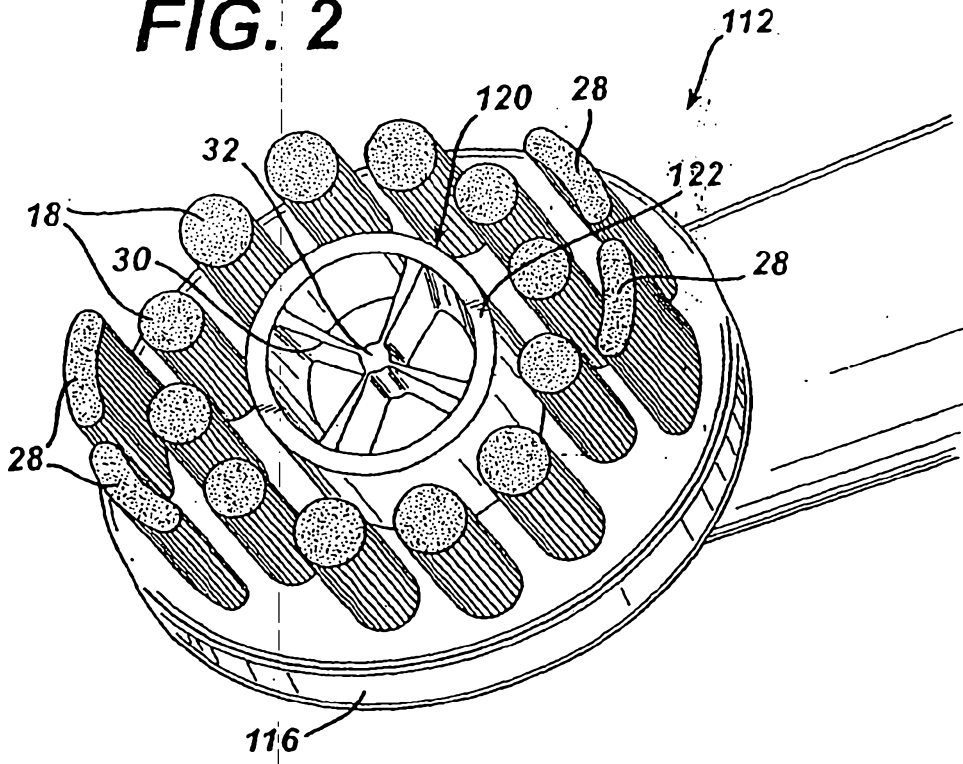

FIG. 3

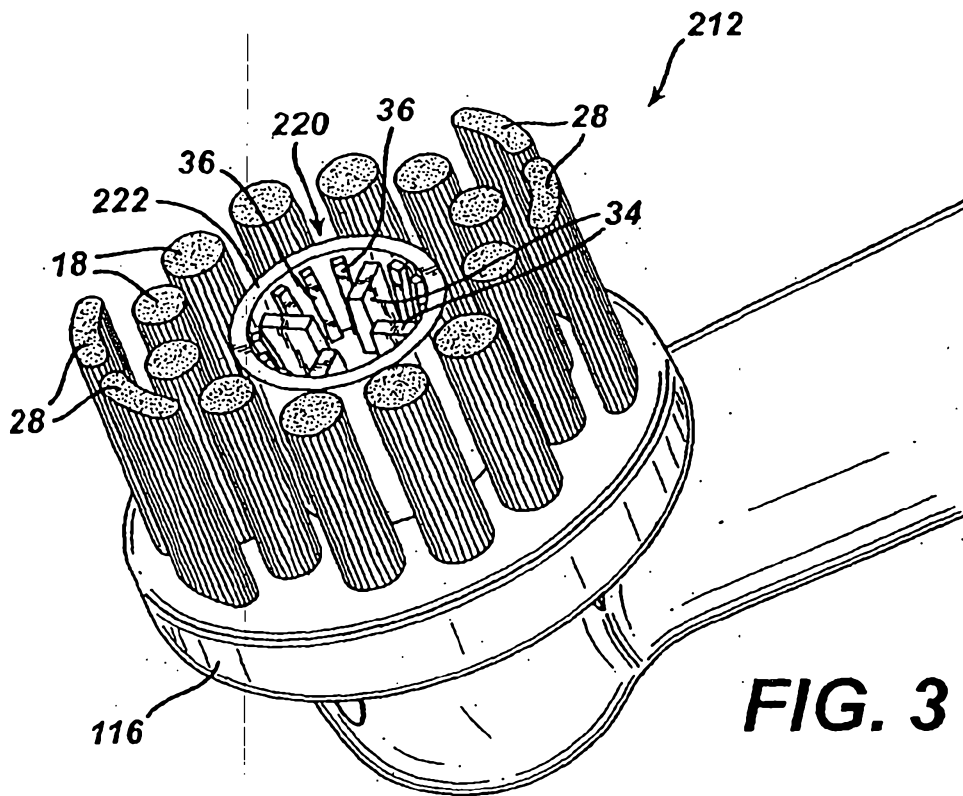

FIG. 2A

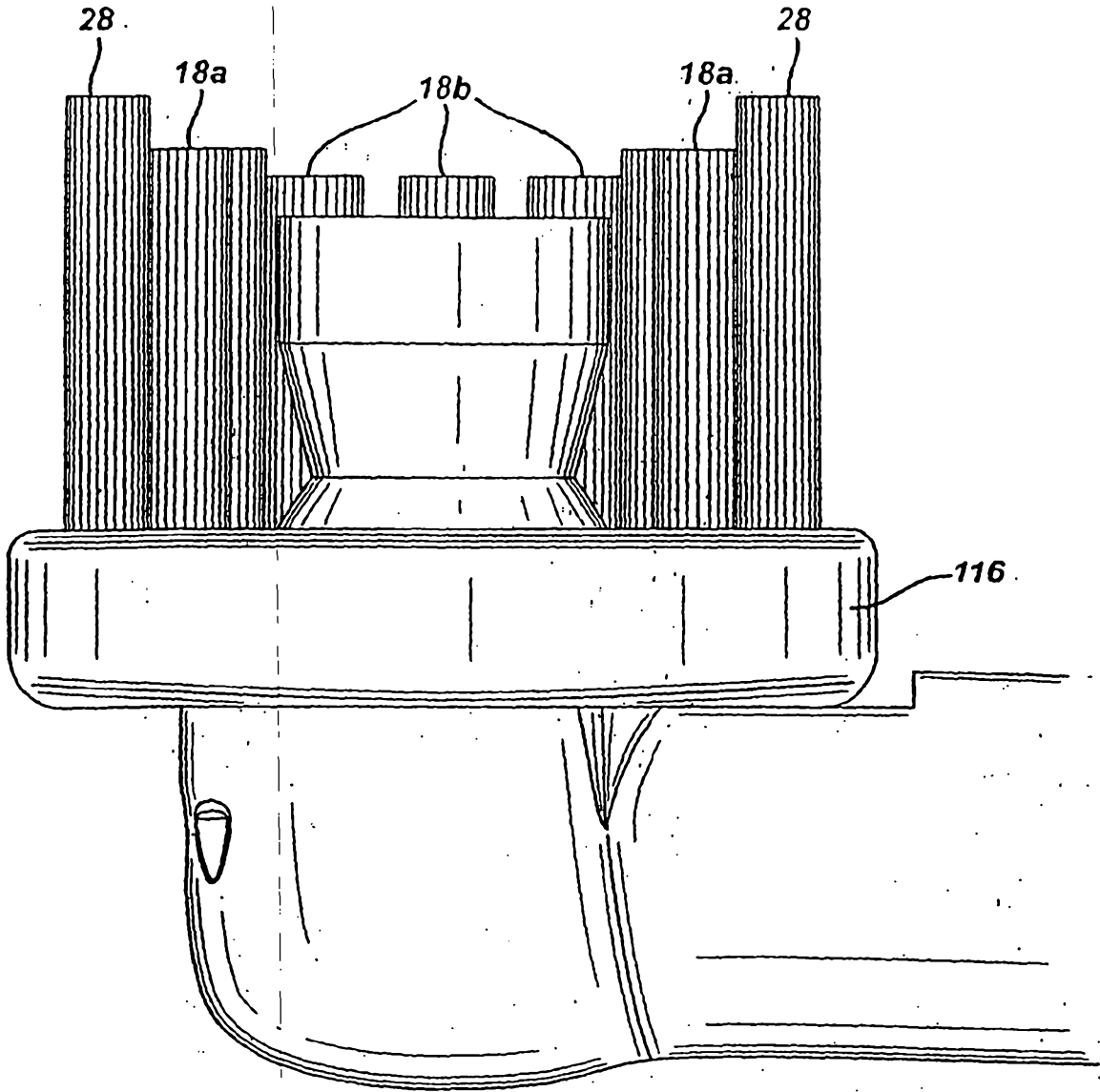
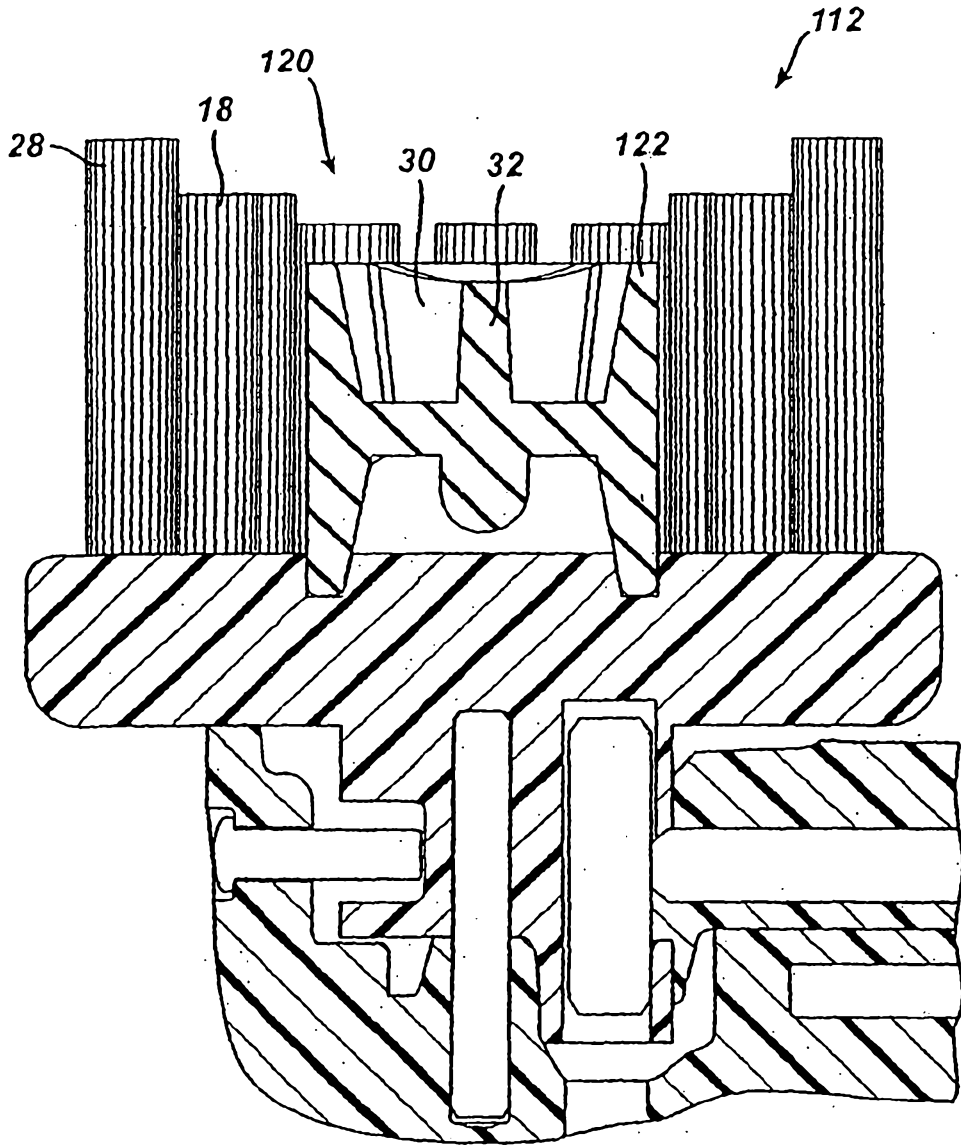
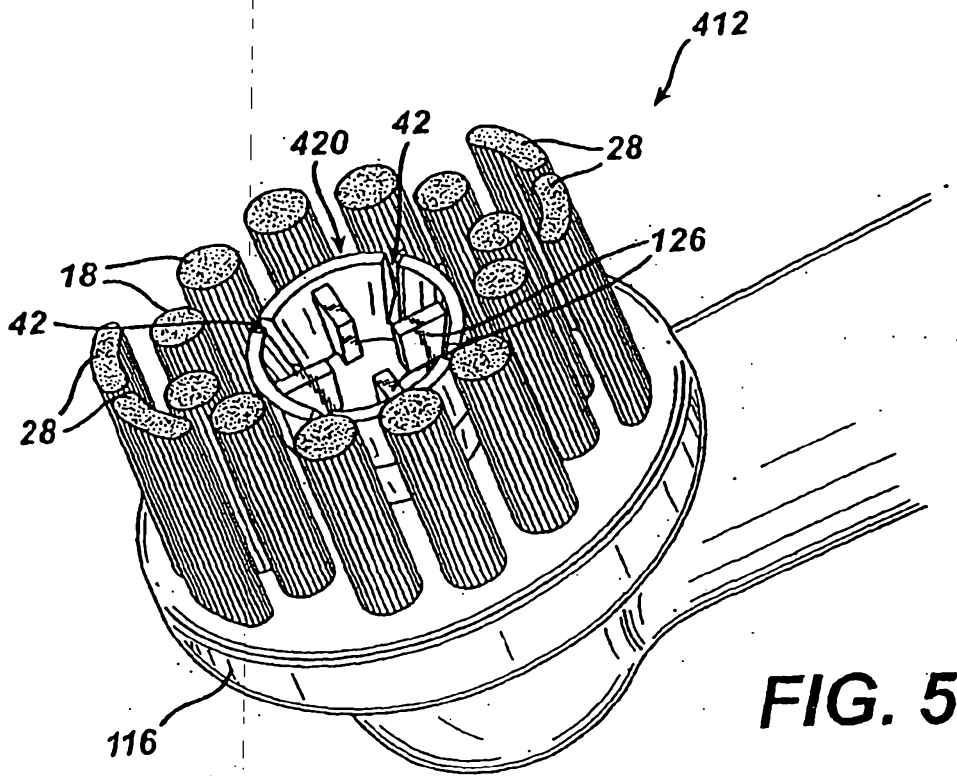
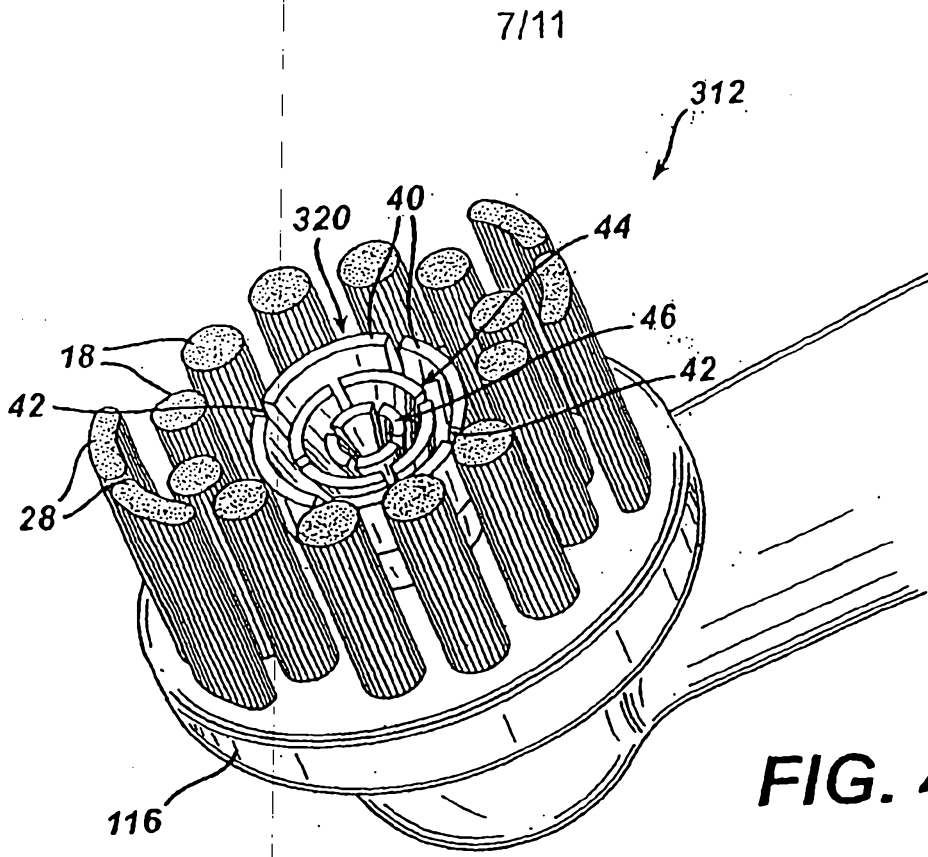

FIG. 2B





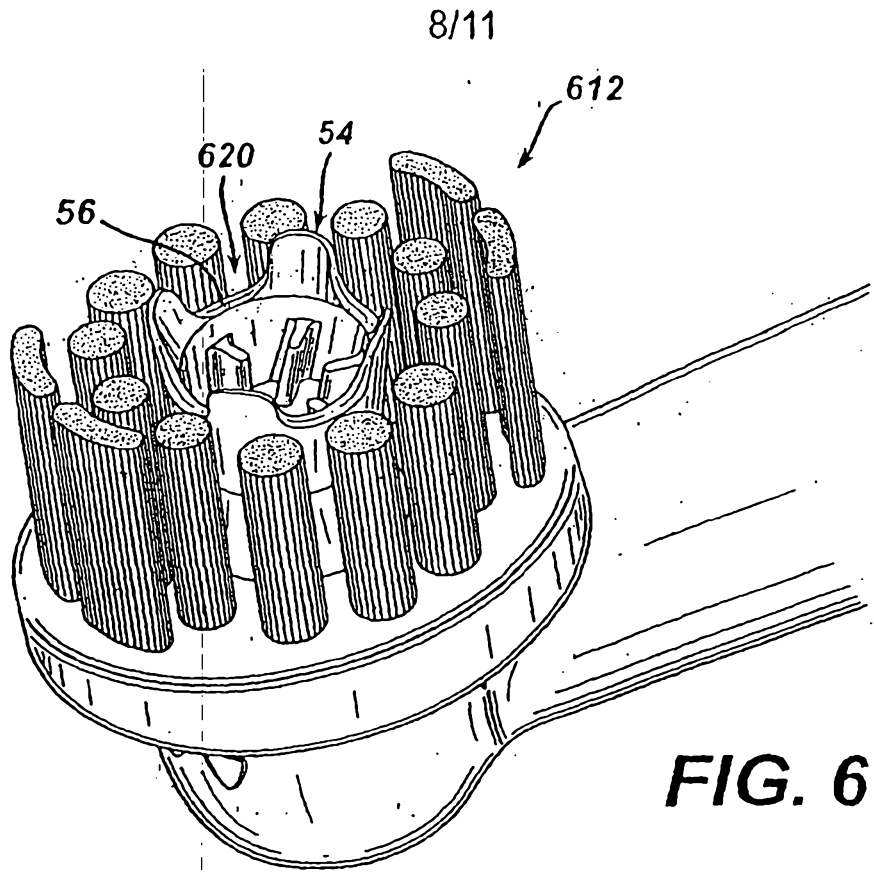

FIG. 6

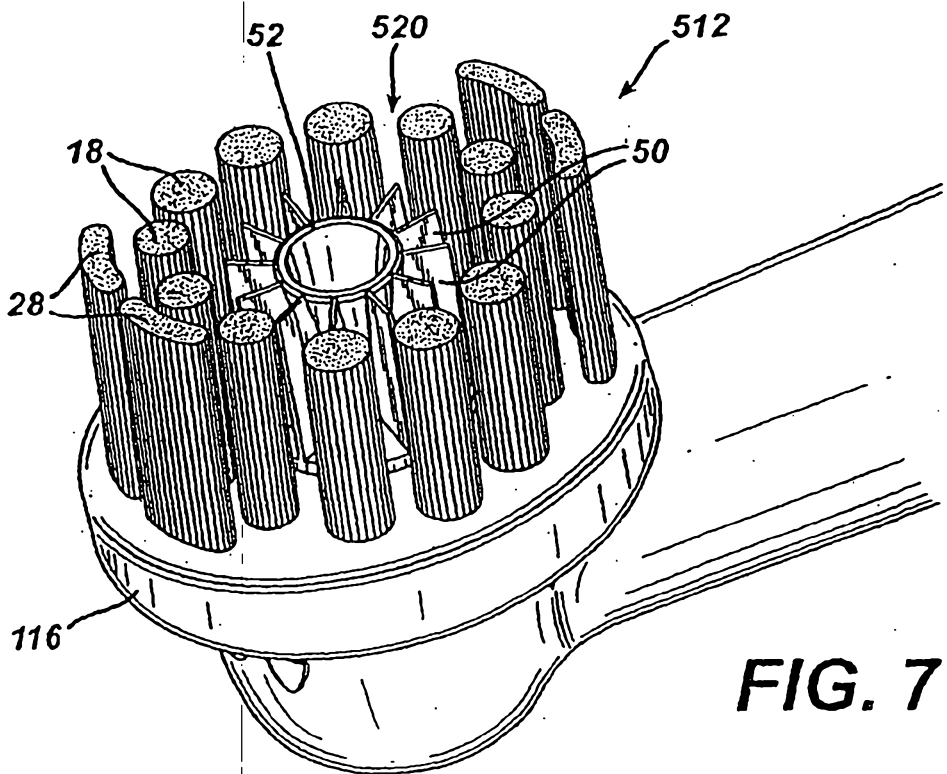

FIG. 7

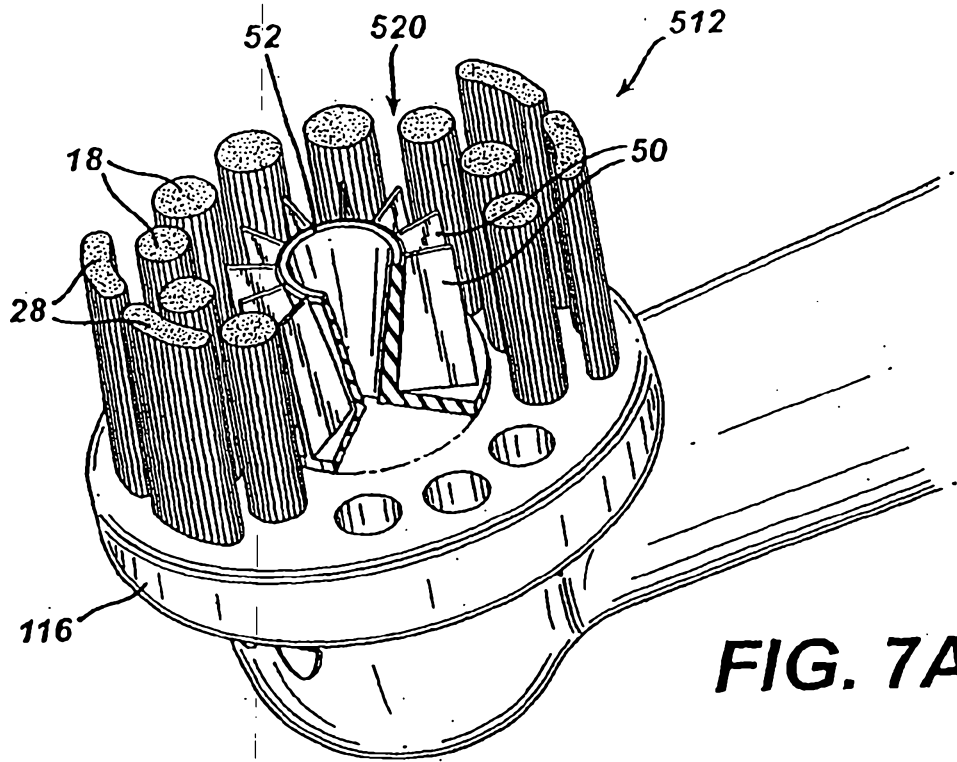
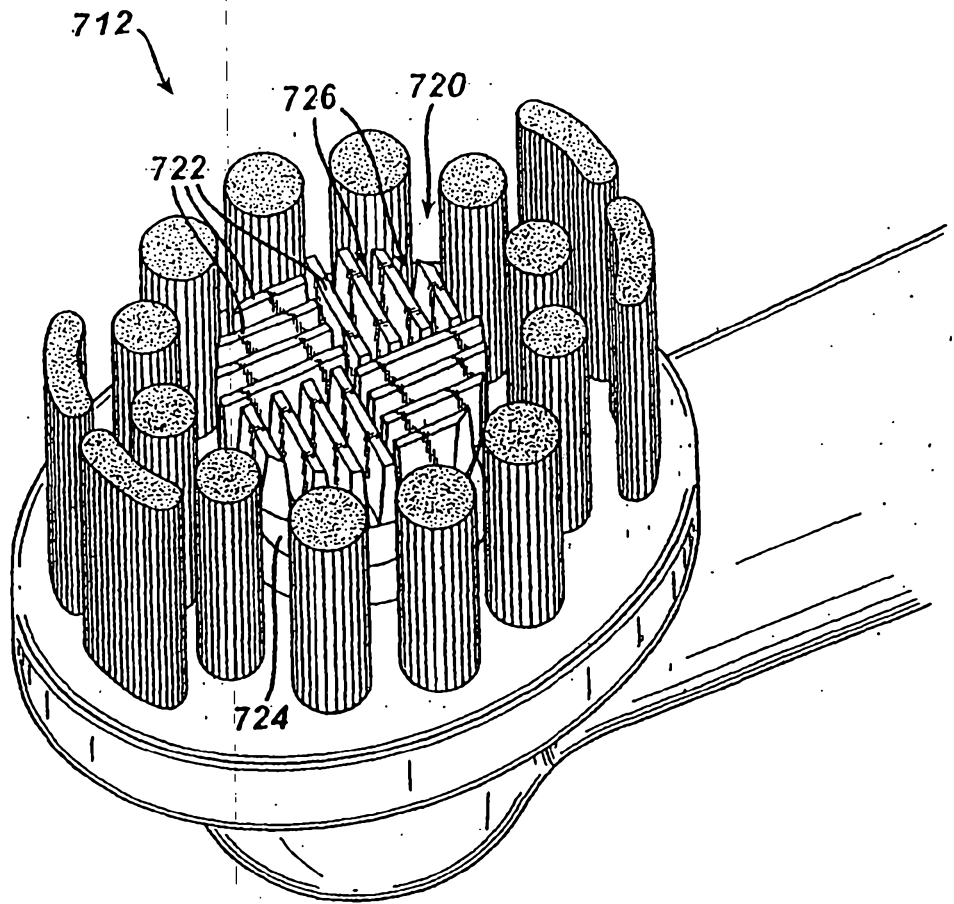

FIG. 7A

FIG. 8



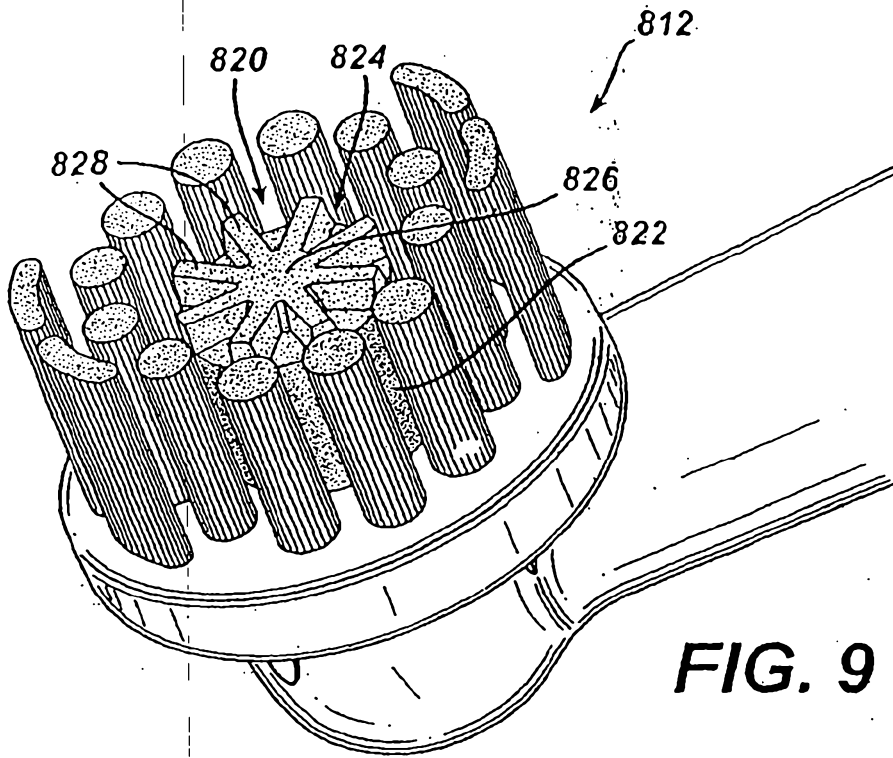

FIG. 9

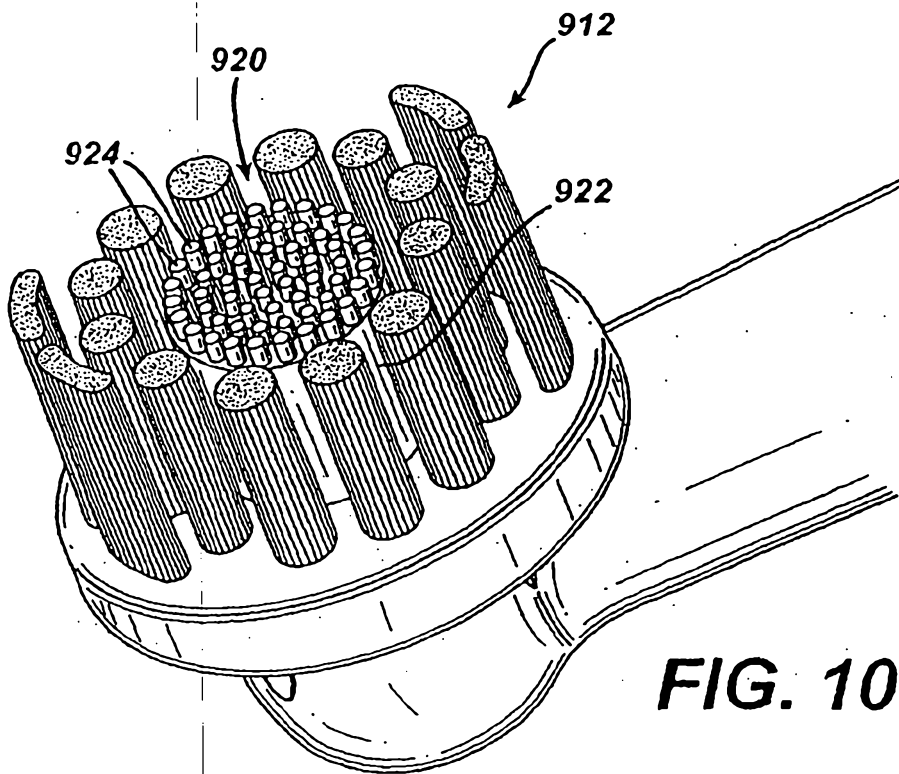

FIG. 10