



US007248312B2

(12) **United States Patent**
Jun et al.

(10) **Patent No.:** **US 7,248,312 B2**
(45) **Date of Patent:** **Jul. 24, 2007**

- (54) **LIQUID CRYSTAL DISPLAY PANEL AND FABRICATING METHOD THEREOF**
- (75) Inventors: **Jaе Hong Jun**, Seoul (KR); **Jung Jae Lee**, Gwanchun-shi (KR)
- (73) Assignee: **LG.Philips LCD Co., Ltd.**, Seoul (KR)
- (*) Notice: Subject to any disclaimer, the term of this patent is extended or adjusted under 35 U.S.C. 154(b) by 217 days.
- (21) Appl. No.: **10/873,491**
- (22) Filed: **Jun. 23, 2004**
- (65) **Prior Publication Data**
US 2005/0007525 A1 Jan. 13, 2005
- (30) **Foreign Application Priority Data**
Jul. 10, 2003 (KR) 10-2003-0046762
- (51) **Int. Cl.**
G02F 1/1335 (2006.01)
G02F 1/1333 (2006.01)
G02F 1/1339 (2006.01)
- (52) **U.S. Cl.** 349/106; 349/110; 349/155;
349/156

(58) **Field of Classification Search** 349/106,
349/155, 110, 156; 345/88
See application file for complete search history.

(56) **References Cited**

U.S. PATENT DOCUMENTS

- 6,208,401 B1* 3/2001 Wen et al. 349/155
 - 6,424,402 B1* 7/2002 Kishimoto 349/156
 - 6,567,139 B2* 5/2003 Huang 349/110
 - 2004/0012750 A1* 1/2004 Chung et al. 349/155
 - 2004/0263764 A1* 12/2004 Kim et al. 349/155
- * cited by examiner

Primary Examiner—Huyen Ngo
(74) *Attorney, Agent, or Firm*—McKenna Long & Aldridge LLP

(57) **ABSTRACT**

A liquid crystal display panel and a method of fabricating the same are capable of simplifying a fabricating process and forming a spacer at a desired location. A liquid crystal display panel according to the present invention includes: a black matrix formed on an upper substrate; a color pattern having at least one hole on the black matrix; and a spacer protruding from the at least one hole.

16 Claims, 27 Drawing Sheets

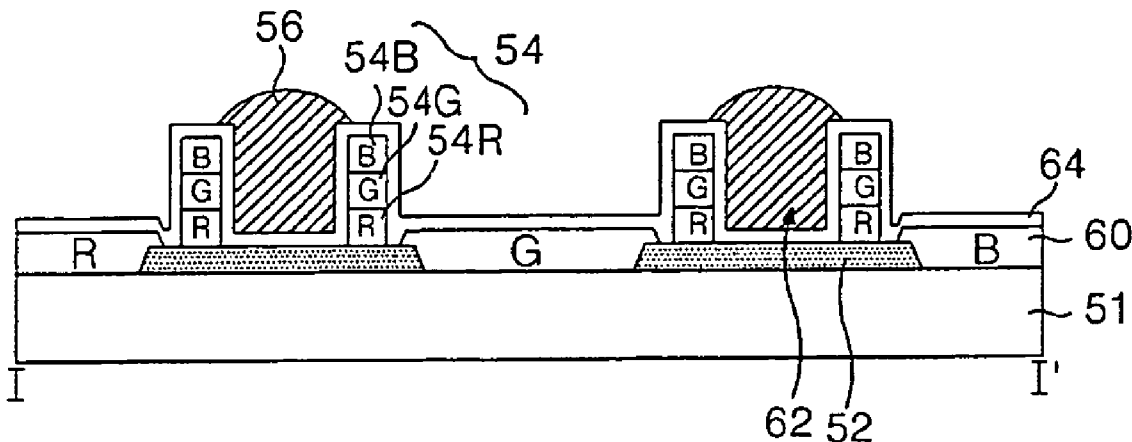

FIG. 1
RELATED ART

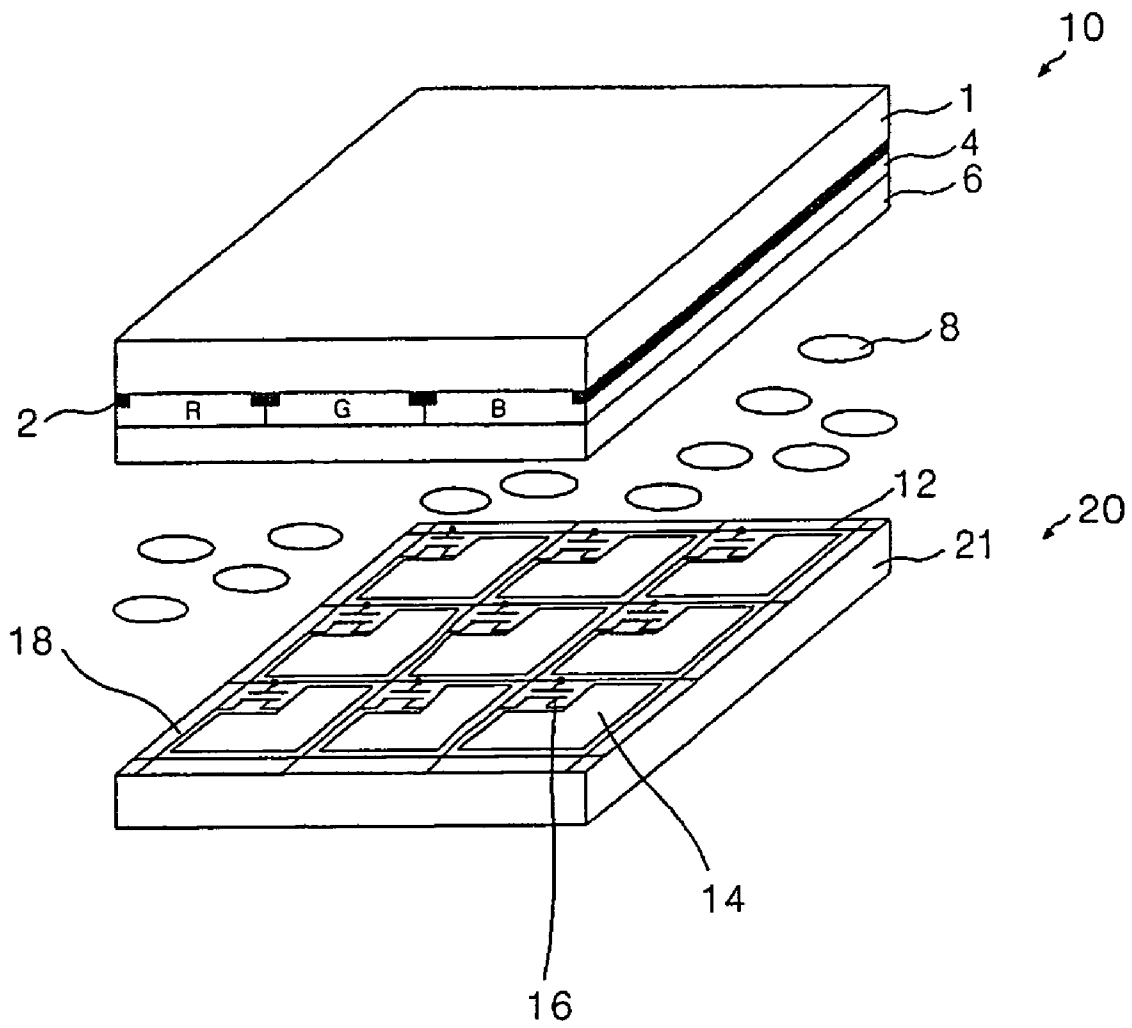

FIG. 2A
RELATED ART

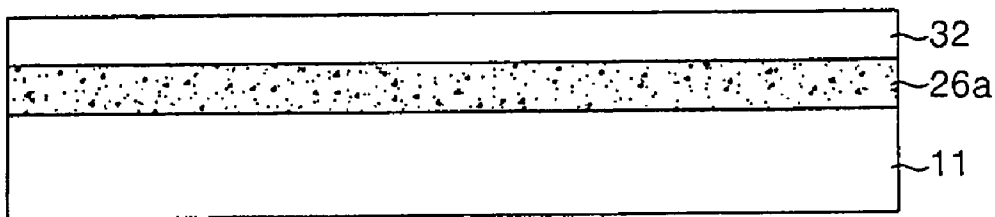

FIG. 2B

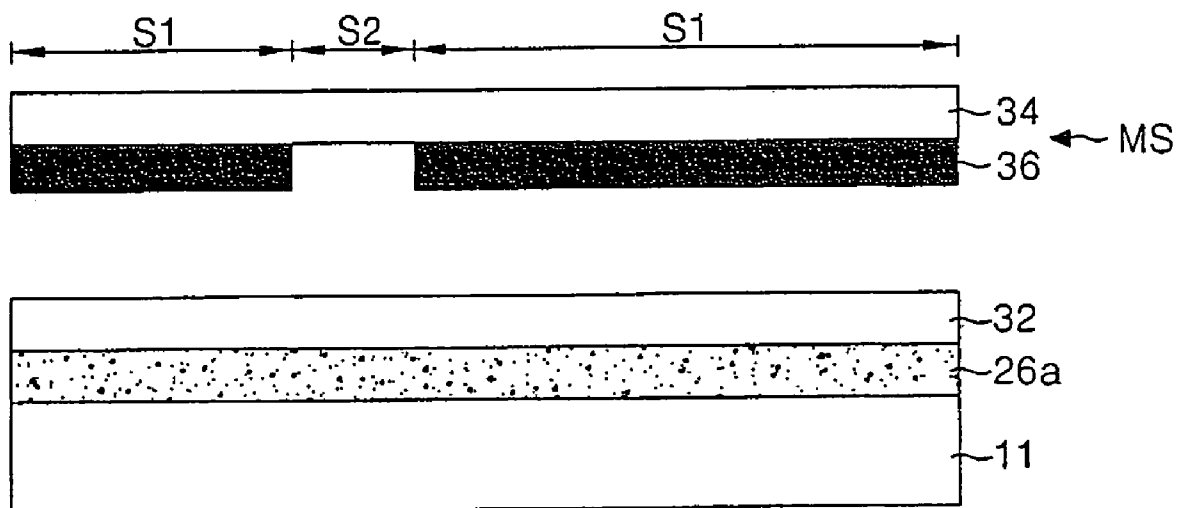

FIG. 2C
RELATED ART

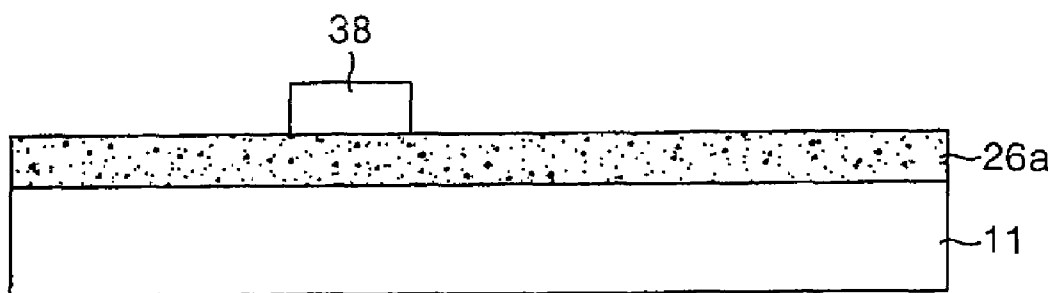

FIG. 2D
RELATED ART

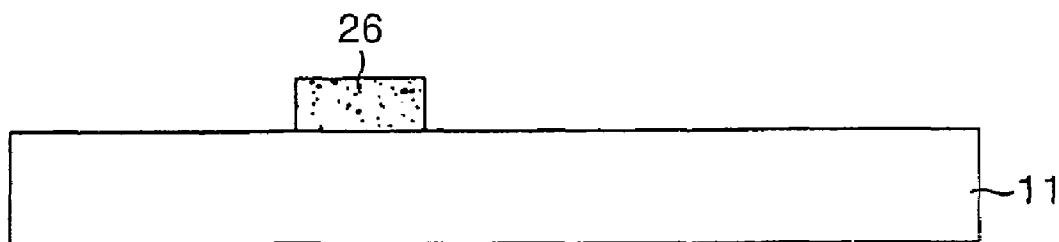

FIG. 3A

RELATED ART

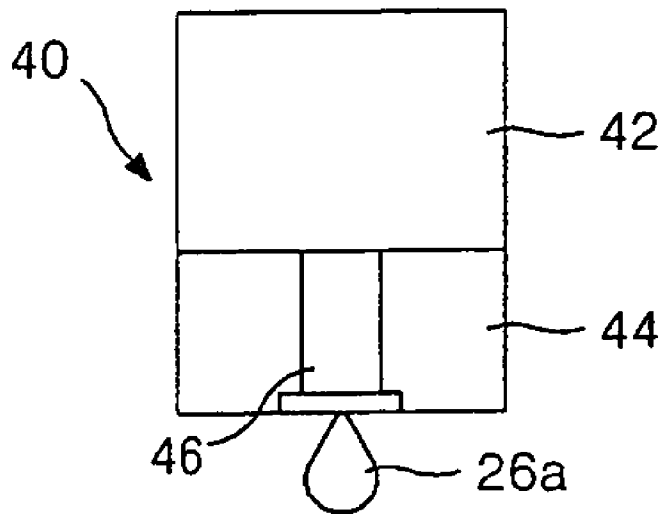

FIG. 3B

RELATED ART

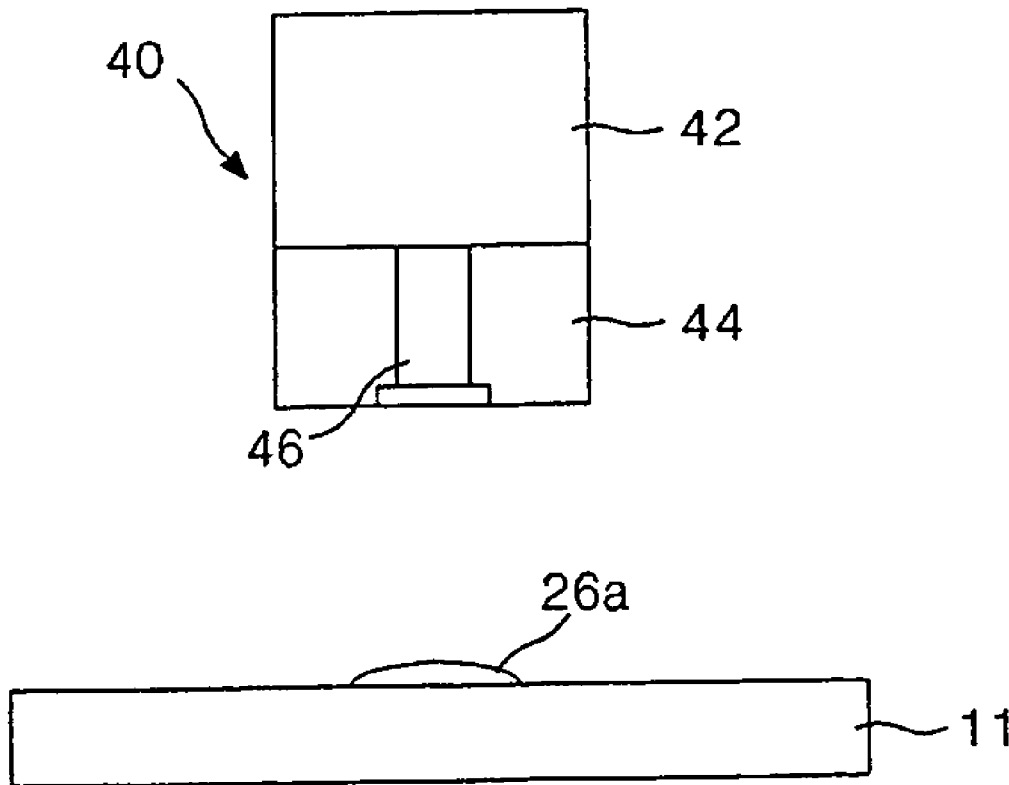

FIG. 3C
RELATED ART

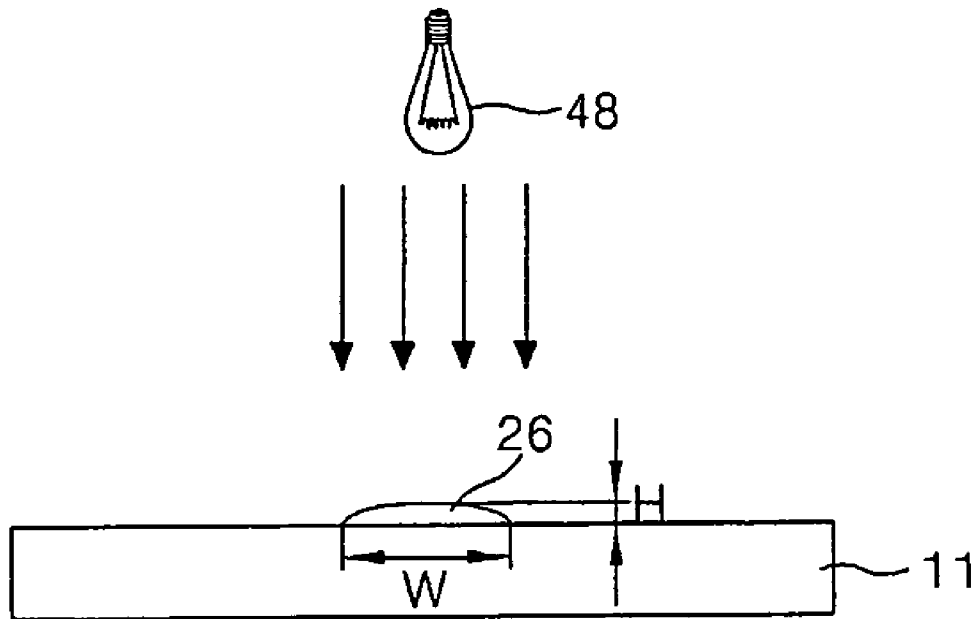

FIG. 4

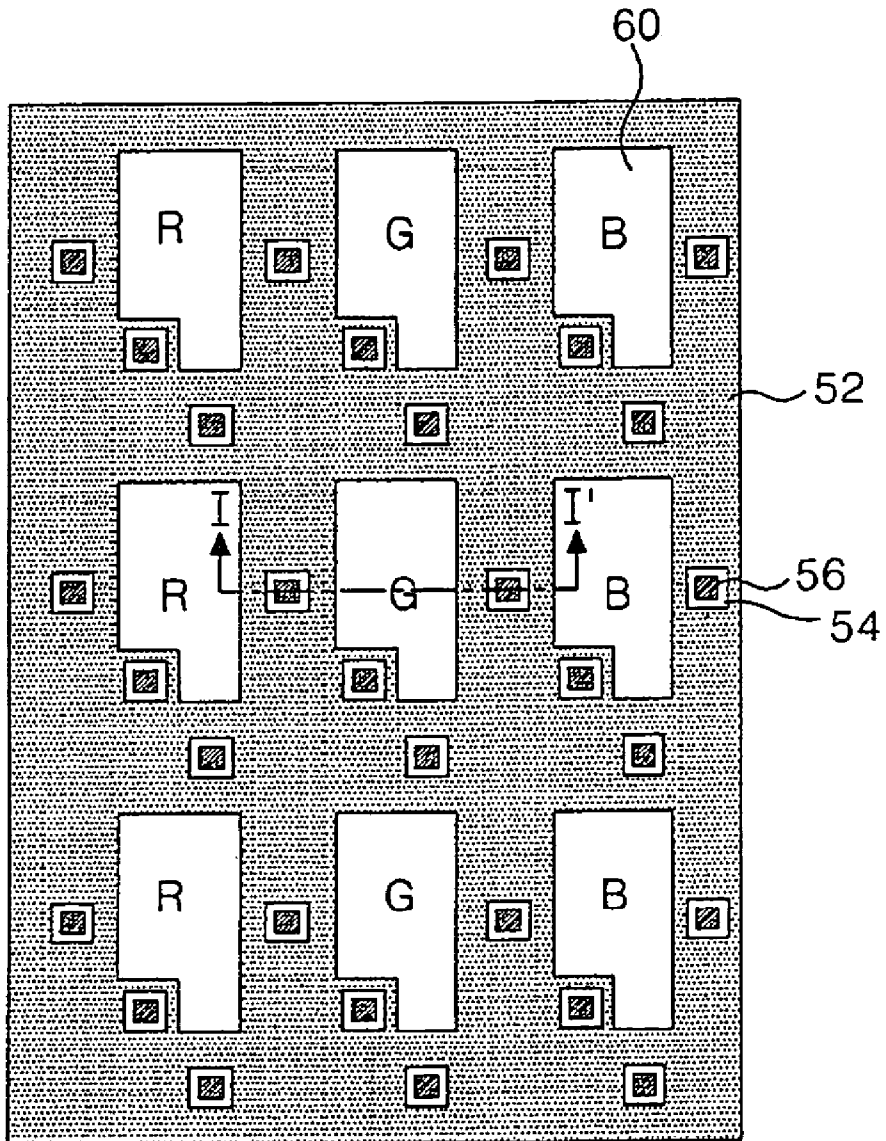

FIG. 5

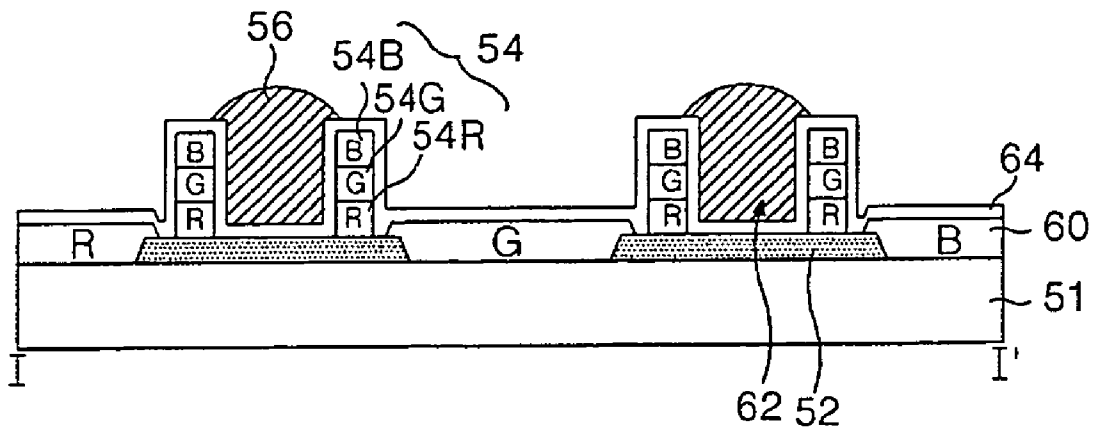

FIG. 6A

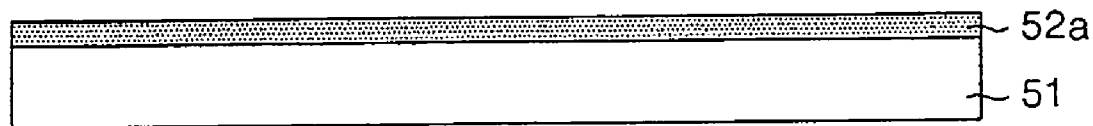

FIG. 6B

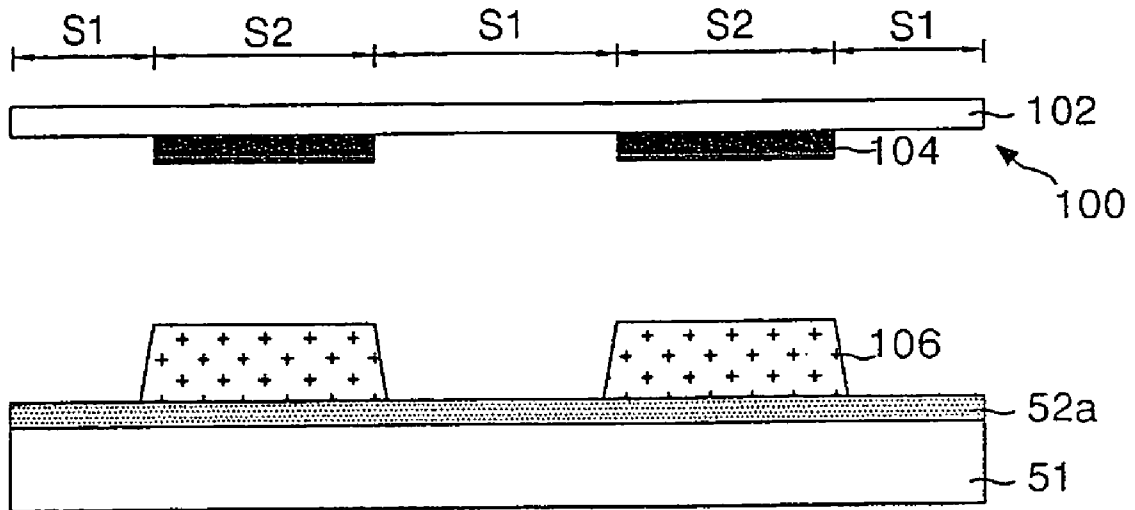

FIG. 6C

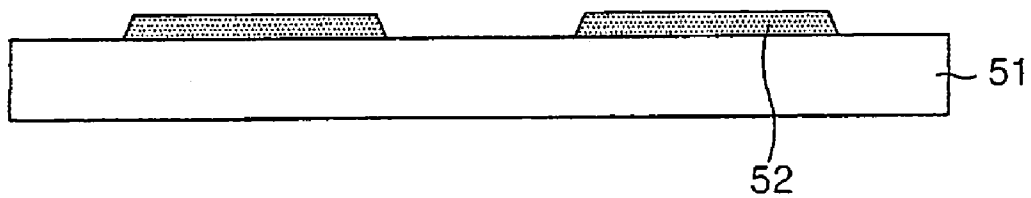

FIG. 7A

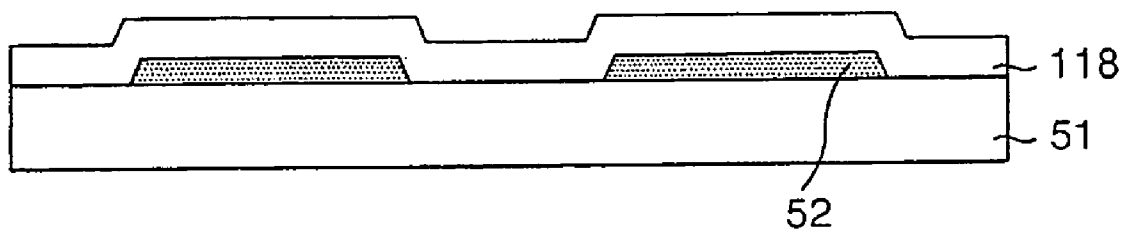

FIG. 7B

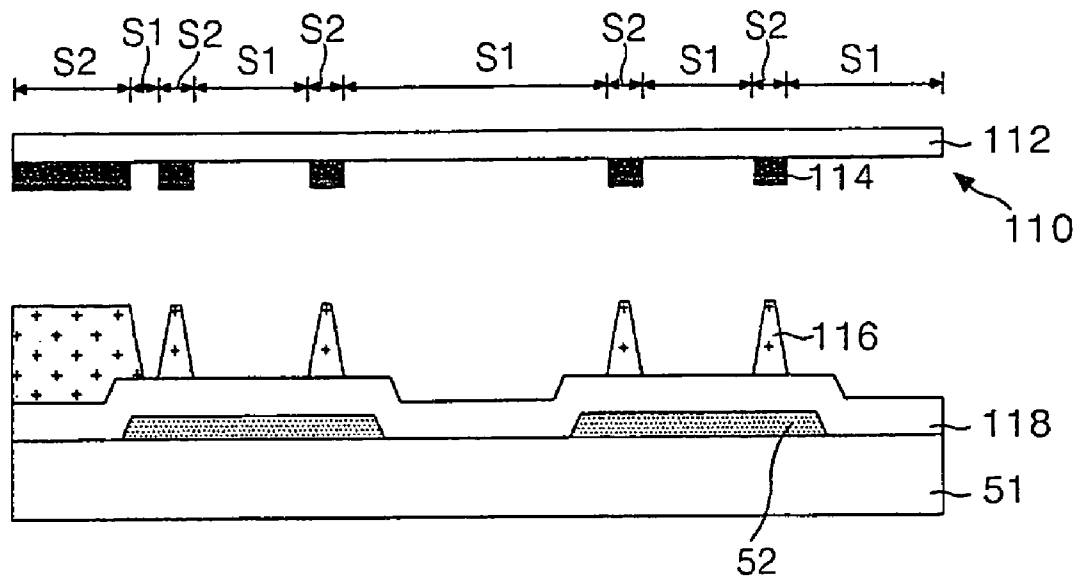

FIG. 7C

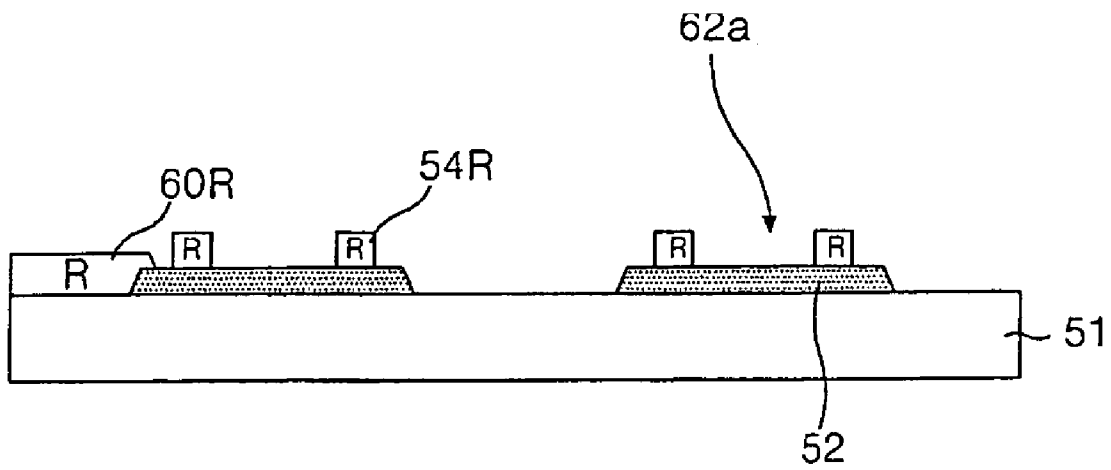

FIG. 8A

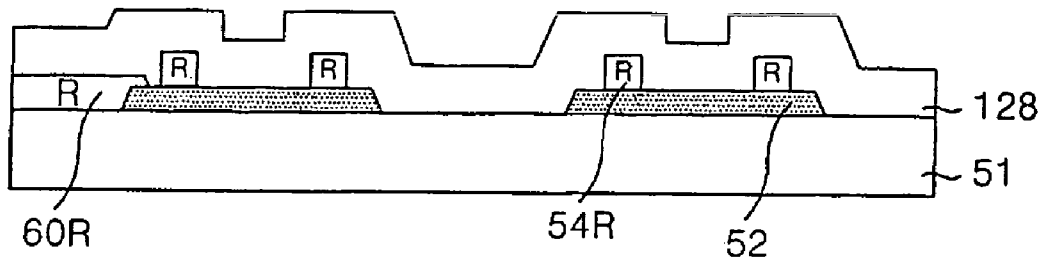

FIG. 8B

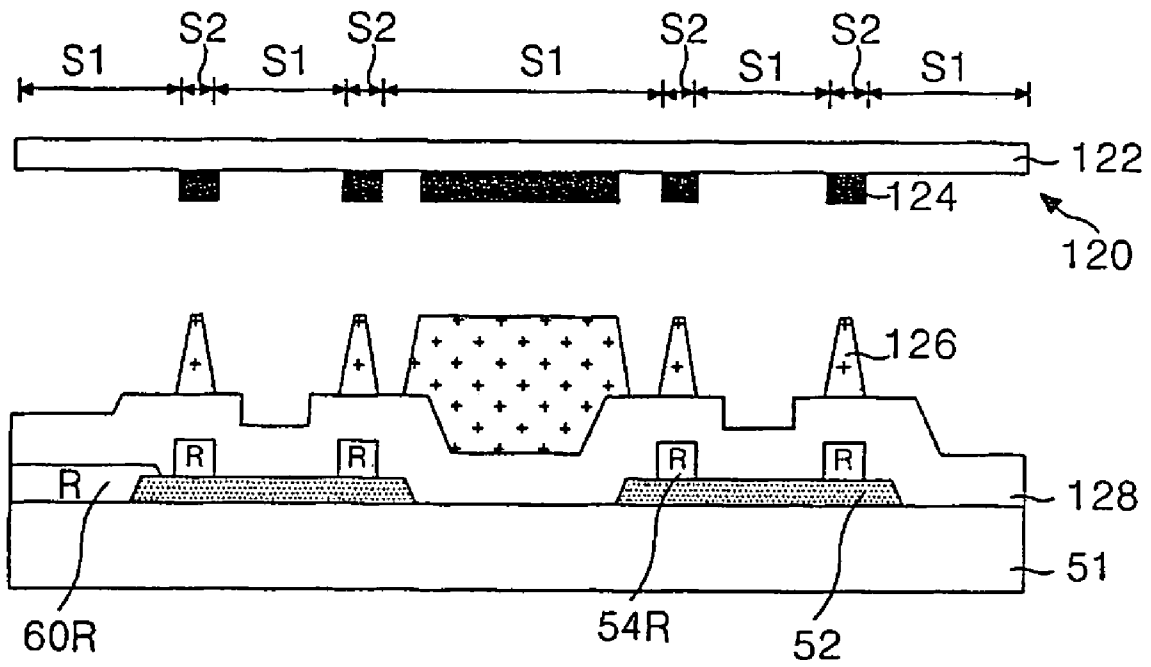

FIG. 8C

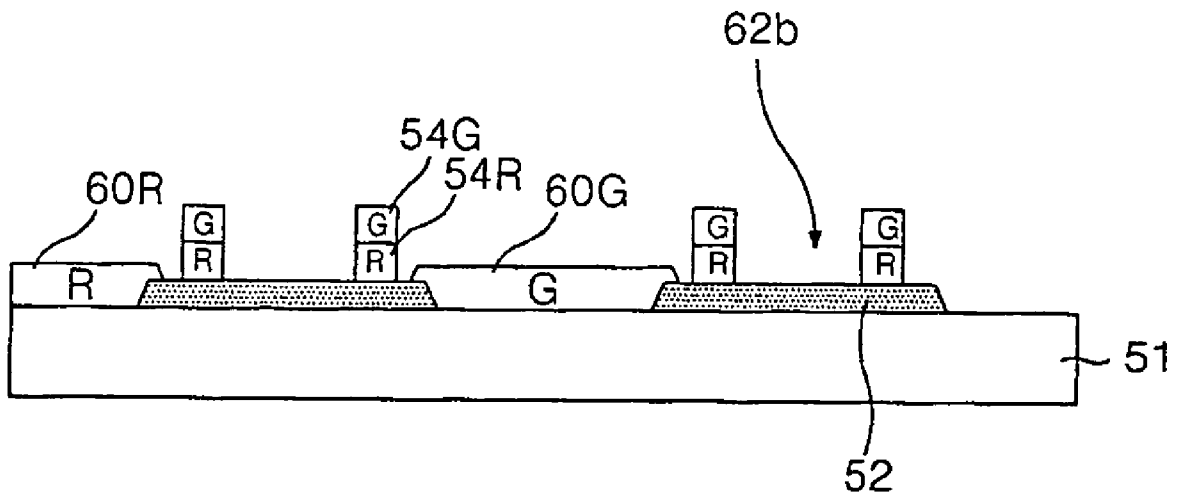

FIG. 9A

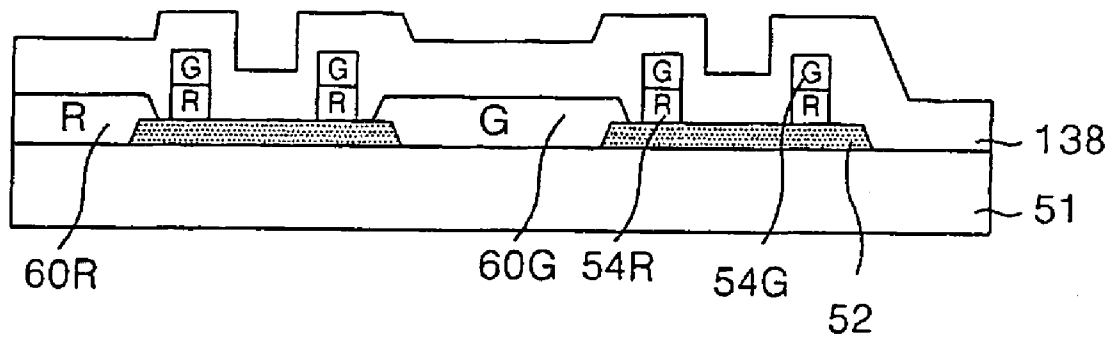

FIG. 9B

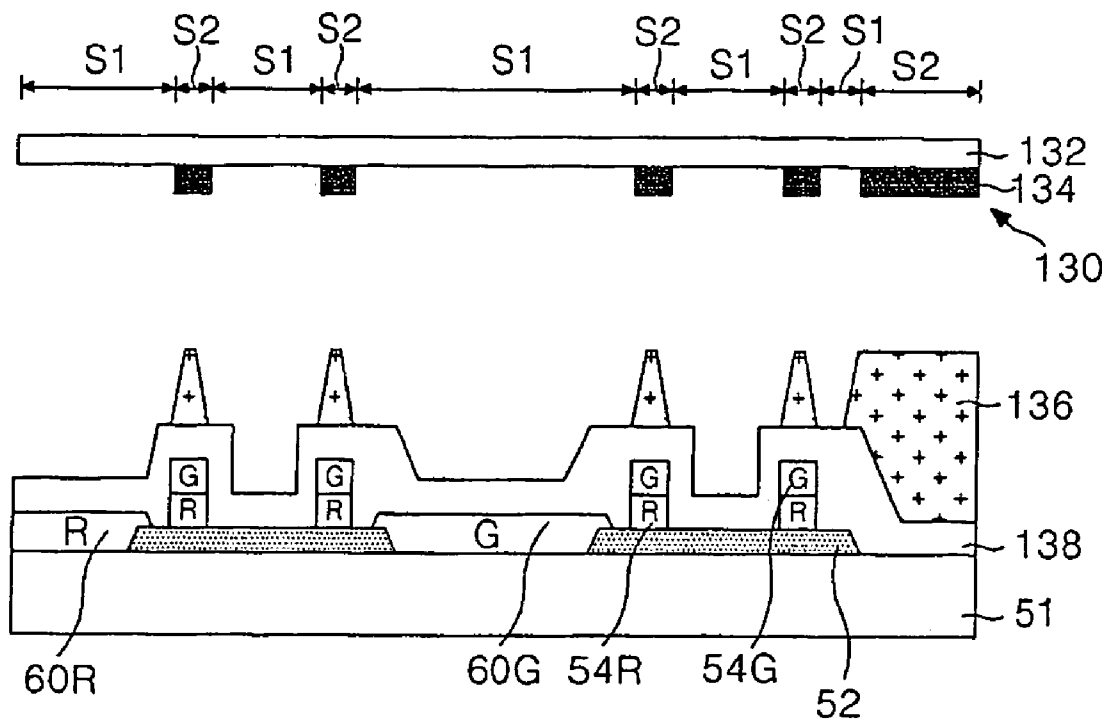

FIG. 9C

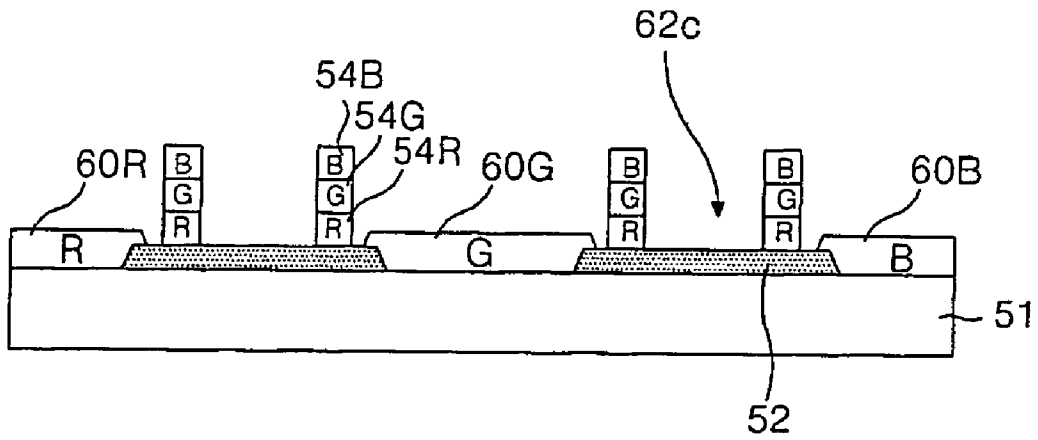

FIG. 10A

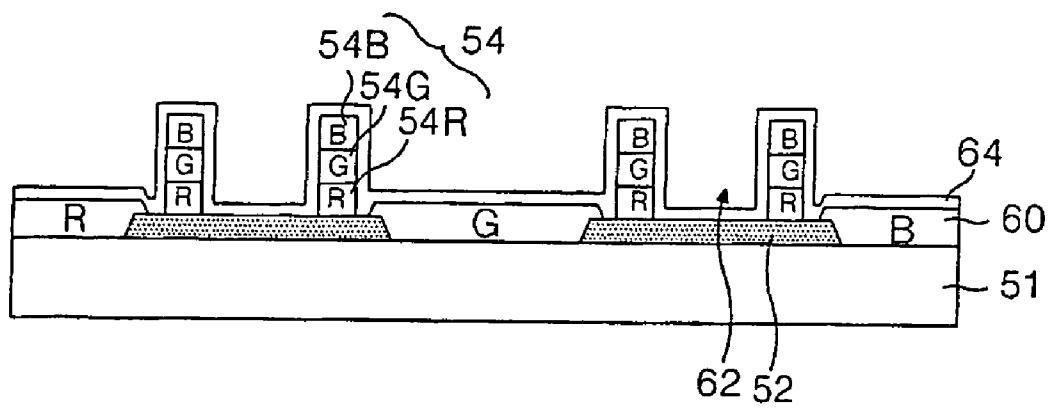

FIG. 10B

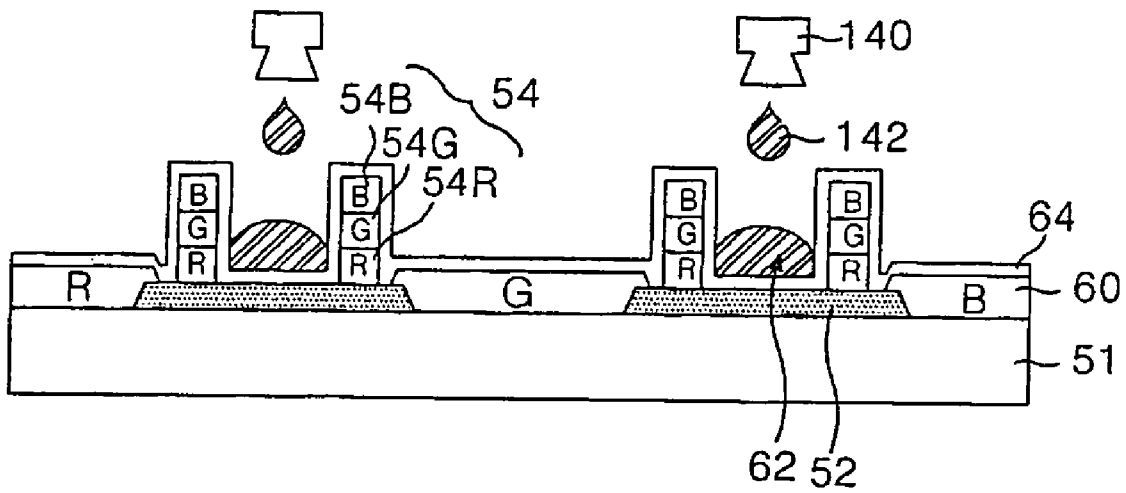

FIG. 10C

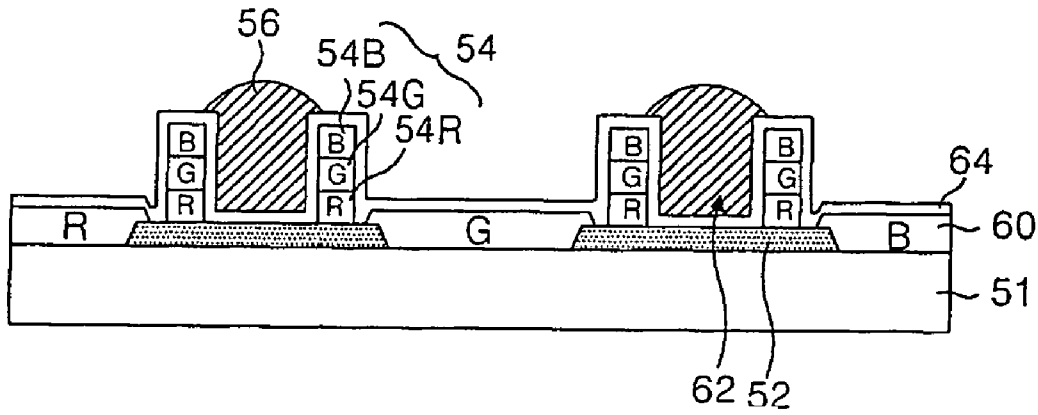

FIG. 11

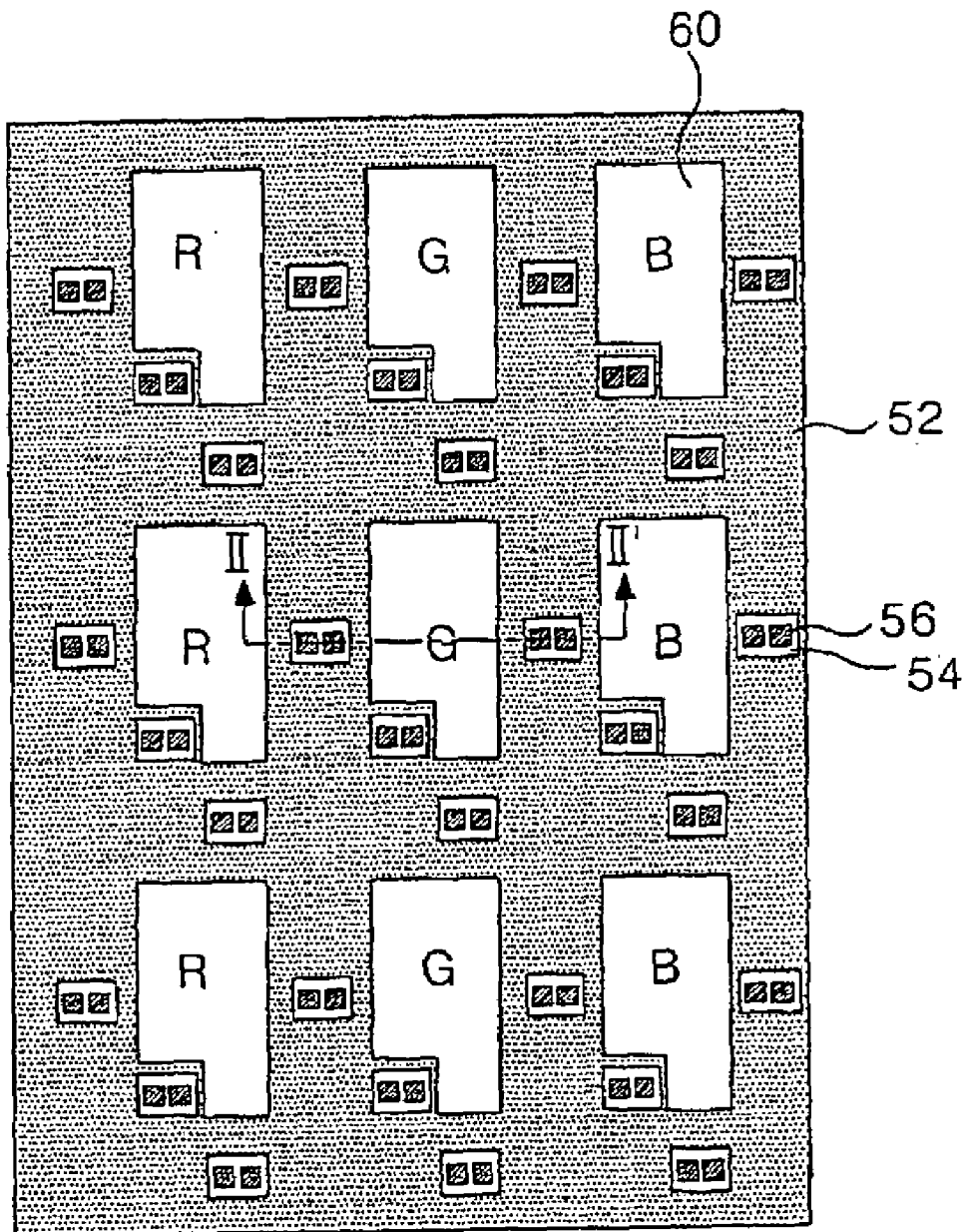
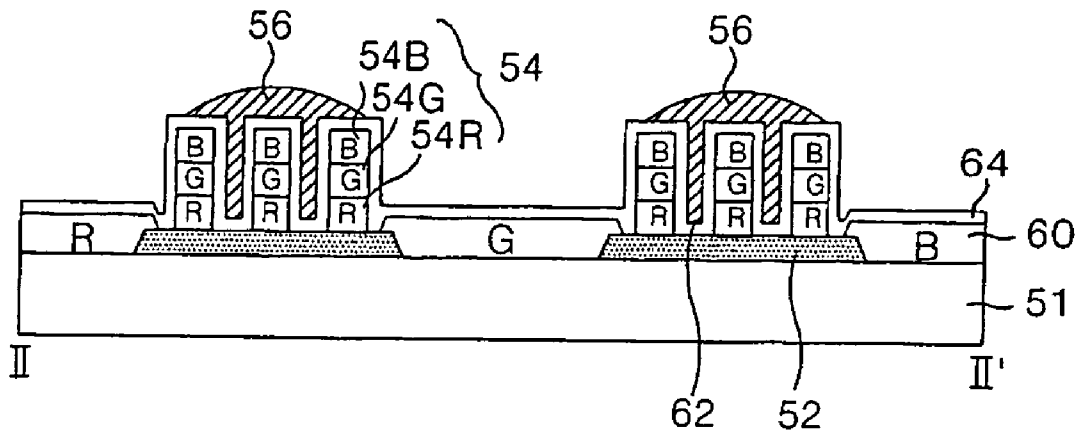

FIG. 12



LIQUID CRYSTAL DISPLAY PANEL AND FABRICATING METHOD THEREOF

This application claims the benefit of Korean Patent Application No. P2003-46762, filed on Jul. 10, 2003, which is hereby incorporated by reference for all purpose as if fully sent forth herein.

BACKGROUND OF THE INVENTION

1. Field of the Invention

The present invention relates to a liquid crystal display panel, and more particularly, to a liquid crystal display panel and a method of fabricating the same that are capable of simplifying a fabricating process and forming a spacer at a desired location.

2. Description of the Related Art

In general, a liquid crystal display (LCD) device controls the light transmittance of liquid crystal cells using an electric field, to thereby display a picture. To this end, the LCD device includes a liquid crystal display panel having liquid crystal cells arranged in an active matrix, and driving circuits for driving the liquid crystal panel. The liquid crystal display panel is provided with pixel electrodes and a reference electrode, i.e., a common electrode, to supply the electric field to each one of the liquid crystal cells. Usually, each pixel electrode is formed for each liquid crystal cell on a lower substrate, while the common electrode is formed as an integrated whole on the entire surface of an upper substrate. Each pixel electrode connects to a thin film transistor (TFT) that is used as a switching element. The pixel electrode together with the common electrode drives the liquid crystal cell in response to data signals supplied via the TFT.

Referring to FIG. 1, there is shown a liquid crystal display panel in accordance with a related art, which includes upper and lower array substrates **10** and **20** combined together, and a liquid crystal material **8** between the upper and the lower array substrates **10** and **20**.

The liquid crystal material **8** rotates, in response to an electric field supplied thereto, to thereby regulate the transmittance of incident light via the lower array substrate **20**.

The upper array substrate **10** includes a color filter **4** and a common electrode **6** formed on a rear surface of the upper substrate **1**. The color filter **4** includes color filters of red (R), green (G), and blue (B) and makes it possible to display colors by selectively passing light having a specific band of wavelength. A black matrix **2** is placed between the color filters **4** adjacent each other and prevents the degradation of the contrast ratio by absorbing the light incident from the adjacent cells.

The lower array substrate **20** includes: a data line **18** and a gate line **12**, which cross each other and are insulated by a gate insulating layer, formed on the entire surface of the lower substrate **21**; and a TFT **16** at the crossing of the data and the gate lines. The TFT **16** includes: a gate electrode connected to the gate line **12**; a source electrode connected to the data line **18**; and a drain electrode facing to the source electrode with a channel portion including an active layer and an ohmic contact layer therebetween. The TFT **16** is connected to the pixel electrode **14** via a contact hole passing through a passivation film. In response to gate signals from the gate line **12**, the TFT **16** selectively supplies data signals from the data line **18** to the pixel electrode **14**.

The pixel electrode **14** is made from a transparent conductive material having a high light transmittance and is in a cell region defined by the data line **18** and gate line **12**. The

pixel electrode **14** generates a potential difference along with a common electrode **6** by data signals supplied via the drain electrode. Under the influence of the potential difference, the liquid crystal material **8** between the upper and lower substrates **1** and **21** rotates due to the dielectric anisotropy thereof. Hence, the light supplied via the pixel electrode **14** from the light source passes toward the upper substrate **1**.

The cell gap between the upper and the lower array substrates **10** and **20** is maintained by spacers and a liquid crystal material is injected in the space maintained by the spacers.

Meanwhile, the spacers for maintaining the cell gap are formed by a fabricating method shown FIGS. 2A to 2D.

First of all, as shown in FIG. 2A, mixed material of solvent, binder, monomer, and photo-initiator is printed and dried so as to evaporate the solvent, and then spacer material **26a**, which is a mixture of binder, monomer and photo-initiator, is formed. Here, either the lower substrate having the TFT and the pixel electrode or the upper substrate having the color filter may be used as the substrate **11**.

After a photo-resist **32** is applied on the substrate **11** having the spacer material **26a** formed thereon, a photo mask MS is aligned as shown in FIG. 2B. The photo mask MS includes a mask substrate **34** having an exposure area **S2** which is an exposed area, and a shielding layer **36** formed on the mask substrate **34** to have a shielding area **S1**.

By carrying out the exposure process to selectively irradiate ultraviolet rays to the photo-resist **32** using the photo mask MS and the development process to develop the exposed photo-resist, a photo-resist pattern **38** is formed as shown in FIG. 2C. The spacer material **26a** is patterned through an etching process using the photo-resist pattern as a mask, and consequently, a pattern spacer having designated height is formed as shown in FIG. 2D.

The pattern spacer **26** of the related art LCD occupies only about 2% of the area of the substrate **11**. More than 95% of the spacer material **26a** that has been printed on the entire surface of the substrate **11** to form the pattern spacer **26** is removed during the processes of exposure, development, and etching. So, the spacer material is inadvertently wasted, and the costs of dedicated material and fabrication become high. Further, the additional mask process for forming the pattern spacer **26** including the processes such as printing, exposure, development, and etching leads to the problem that makes the fabricating process even more complex.

In order to solve these problems, a fabricating method for the spacer using an ink-jet device has been suggested as shown in FIGS. 3A to 3C.

First, as shown in FIG. 3A, an ink-jet device **40** is aligned so as to overlap with the location where the spacer is to be formed on the substrate **11**. Here, either the lower substrate **21** having the TFT **16** and the pixel electrode **14** or the upper substrate having the color filter **4** may be used as the substrate **11**.

Then, the spacer material **26a** is dispensed onto the substrate **11** from the ink-jet device **40** as shown in FIG. 3B. In other words, when an external voltage is supplied to a piezoelectric element of an ink-jet head, physical pressure is generated. This physical pressure causes a conduit connecting a tank **42** containing the spacer material **26a** with a nozzle to contract and relax repeatedly, and thereby the spacer material **26a** is dispensed onto the substrate **11** through a nozzle **46**.

The pattern spacer **26** formed by being dispensed the spacer material **26a** through the nozzle **46** of the ink-jet device thereafter undergoes an exposure to the ultraviolet

ray radiated from a light source **48** or a firing process as shown in FIG. **3C**, and then comes to have designated width **W** and height **H**.

During the formation of the spacer using the related art ink-jet device, the spacer material **26a** of low viscosity experiences gravity while being dispensed onto the substrate **11**. Due to gravity, the spacer material **26a** spreads out widely with undesirably small ratio of height **H** to width **W** when dispensed onto the substrate. This leads to the problem that the pattern spacer **26** that overlaps with the black matrix **2** encroaches on an area outside the black matrix **2**, i.e., a display area and appears as a stain on the display area.

SUMMARY OF THE INVENTION

Accordingly, a primary advantage of the present invention is to provide a liquid crystal display panel and a fabricating method thereof that are capable of simplifying a fabricating process and forming a spacer at a desired location.

In order to achieve these advantages of the invention, according to one aspect of the present invention, a liquid crystal display panel includes: a black matrix formed on an upper substrate; a color pattern having at least one hole on the black matrix; and a spacer protruding from the at least one hole.

The color pattern has a structure having two layers.

The color pattern is formed by stacking a red color pattern, a green color pattern and a blue color pattern.

The color pattern has a width less than that of the black matrix.

A width of the color pattern narrows from an uppermost layer to a lowermost layer.

The color pattern may have an identical width in each layer.

A height of the spacer increases as the number of holes of the color pattern increases.

The liquid crystal display panel may include a common electrode located between the color filter and the spacer.

The spacer may be formed by using an inkjet system.

In order to achieve these advantages of the invention, according to one aspect of the present invention, a method of fabricating a liquid crystal display panel includes: forming a black matrix on a substrate; forming a color filter at each area partitioned by the black matrix; forming a color filter having at least one hole on the black matrix; and forming a spacer protruding in the at least one hole.

The color pattern may have a structure having two layers.

The step of forming the color pattern includes: forming a red color pattern on the black matrix; forming a green color pattern on the red color pattern; and forming a blue color pattern on the green color pattern.

The method of fabricating the liquid crystal display panel may further include forming a common electrode located between the color filter and the spacer.

BRIEF DESCRIPTION OF THE DRAWINGS

These and other advantages of the invention will be apparent from the following detailed description of the embodiments of the present invention with reference to the accompanying drawings, in which:

FIG. **1** is a perspective view representing a related art liquid crystal display panel;

FIGS. **2A** to **2D** are sectional views representing a fabricating method of a typical pattern spacer;

FIGS. **3A** to **3C** are configurations representing a fabricating method of a spacer using a related art inkjet device;

FIG. **4** is a plan view representing an upper array substrate according to a first embodiment of the present invention;

FIG. **5** is a sectional view representing the upper array substrate of the liquid crystal display panel taken along line I-I' in FIG. **4**;

FIGS. **6A** to **6C** are sectional views illustrating a fabricating method of the black matrix shown in FIG. **5**;

FIGS. **7A** to **7C** are sectional views illustrating the red color filter shown in FIG. **5** and a fabricating method thereof;

FIGS. **8A** to **8C** are sectional views illustrating the green color filter shown in FIG. **5** and a fabricating method thereof;

FIGS. **9A** to **9C** are sectional views illustrating the blue color filter shown in FIG. **5** and a fabricating method thereof;

FIGS. **10A** to **10C** are sectional views illustrating a fabricating method of the common electrode and the spacer shown in FIG. **5**;

FIG. **11** is a plan view representing an upper array substrate according to a second embodiment of the present invention; and

FIG. **12** is a sectional view representing the upper array substrate of the liquid crystal display panel taken along line II-II' in FIG. **11**.

DETAILED DESCRIPTION OF THE ILLUSTRATED EMBODIMENT

Reference will now be made in detail to the preferred embodiments of the present invention, examples of which are illustrated in the accompanying drawings.

Hereinafter, the preferred embodiments of the present invention will be described in detail with reference to FIGS. **4** to **12**.

FIG. **4** is a plan view representing an upper array substrate according to a first embodiment of the present invention and FIG. **5** is a sectional view representing an upper array substrate of the liquid crystal display panel taken along line I-I' in FIG. **4**.

Referring to FIGS. **4** and **5**, the upper array substrate of the liquid crystal display panel includes a black matrix **52**, a color filter **60**, a color pattern **54**, a common electrode **64** and a spacer **56** on an upper substrate **51**.

The black matrix **52** is formed in a matrix on the upper substrate **51**, partitions the upper substrate **51** into a plurality of cell regions at which the color filters **60** are to be formed and prevents the leakage of light between adjacent cells. This black matrix is formed so as to overlap with the area excluding the pixel electrode on the lower array substrate, that is, TFTs, gate lines, and data lines.

The color filter **60** is formed at the cell region partitioned by the black matrix **52**. This color filter **60** is formed using separate red R, green G and blue B filters to realize red, green, and blue colors.

The color pattern **54** is formed with a round or a polygon shape having a spacer hole **62**. The color pattern **54** has at least two color patterns, which are different from each other, on the black matrix **52**. Herein, for example, an explanation on the color pattern **54** in which a red color pattern **54R**, a green color pattern **54G** and a blue color pattern **54B** are sequentially stacked will be made as follows. The red color pattern **54R** is formed to have a first spacer hole on the black matrix **52**. The green color pattern **54G** has a second spacer hole overlapped with the first spacer hole and formed to have a width identical to that of the red color pattern **54R** or a width smaller than that of the red color pattern **54R**. The blue

color pattern **54B** has a third spacer hole overlapped with the second spacer hole and formed to have a width identical to the green color pattern **54G** or a width smaller than that of the green color pattern **54G**. Each of the red, the green and the blue patterns **54R**, **54G** and **54B** is formed of a material identical to the red, the green and the blue color filters **60** and at the same time.

The common electrode **64** is formed on the upper substrate **51** provided with the color filter **60**, the color pattern **54** and the black matrix **52**. A reference voltage for driving the liquid crystal material is supplied to the common electrode **64**.

The spacer **56** maintains the cell gap between the upper substrate and the lower substrate. The spacer **56** is formed on the upper substrate **51** so as to overlap with at least one of a gate line, a data line, and a TFT. At this time, the spacer material is dispensed into the spacer hole **62** arranged within the color pattern **54** by using the inkjet system and is spread out and then is hardened to thereby form the spacer **56**.

As described above, the spacer of the liquid crystal display panel according to the first embodiment of the present invention is formed by filling the spacer material in the spacer hole of the color pattern simultaneously formed with the color filter. Accordingly, the spacer is formed at a desired non-display area by forming the spacer at the spacer hole arranged by the color pattern overlapped with the black matrix. Further, the spacer can be formed thicker than the height of the color pattern by forming the spacer using the inkjet system at the spacer hole in the color pattern. Thus, the costs of dedicated material may be reduced and the fabricating process may be simplified.

FIGS. **6A** to **6C** are configurations illustrating a fabrication method of the black matrix of the upper array substrate of the liquid crystal display panel according to the present invention.

Firstly, an opaque material **52a** is entirely applied to the upper substrate **51**, as shown in FIG. **6A**. The opaque material **52a** is made of an opaque metal including a chrome Cr or an opaque resin. Subsequently, a photo-resist is entirely formed on the opaque material **52a** and then a first mask **100** is aligned on the upper portion of the upper substrate **51** as shown in FIG. **6B**. The first mask **100** is made of a transparent substance and includes a mask substrate **102** in which an exposed area becomes an exposure area **S1**, and a shielding part **104** formed at a shielding area **S2** of the mask substrate **102**.

The photo-resist is exposed by using the first mask **100** and developed, so that a photo-resist pattern **106** is formed at the shielding area **S2** corresponding to the shielding part **104** of the first mask **100**. The opaque material **52a** is patterned by an etching process using the photo-resist pattern **106**, therefore, the black matrix **52** is formed as shown in FIG. **6C**.

FIGS. **7A** to **7C** are sectional views illustrating a red color filter of the upper array substrate of the liquid crystal display panel according to the present invention and a fabrication method of the red color pattern.

Firstly, a red resin **118** is entirely deposited on the upper substrate **51** on which the black matrix **52** is formed, as shown in FIG. **7A**. Subsequently, a photo-resist is entirely formed on the red resin **118** and then a second mask **110** is aligned on the upper portion of the upper substrate **51** as shown in FIG. **7B**. The second mask **110** is made of a transparent substance and includes a mask substrate **112** in which an exposed area becomes an exposure area **S1**, and a shielding part **114** formed at a shielding area **S2** of the mask substrate **112**.

The photo-resist is exposed by using the second mask **110** and developed, so that a photo-resist pattern **116** is formed at the shielding area **S2** corresponding to the shielding part **114** of the second mask **110**. The red resin **118** is patterned by an etching process using the photo-resist pattern **116**, therefore, a red color pattern **60R** and a red color pattern **54R** are formed as shown in FIG. **7C**. The red color pattern **54R** has a first spacer hole **62a** and is formed so as to overlap with the black matrix **52**.

FIGS. **8A** to **8C** are sectional views illustrating a green color filter of the upper array substrate of the liquid crystal display panel and a fabricating method of the green color pattern according to the present invention.

Firstly, a green resin **128** is entirely deposited on the upper substrate **51** on which the red color filter **60R** and the red color pattern **54R** are formed, as shown in FIG. **8A**. Subsequently, a photo-resist is entirely formed on the green resin **128** and then a third mask **120** is aligned on the upper portion of the upper substrate **51** as shown in FIG. **8B**. The third mask **120** is made of a transparent substance and includes a mask substrate **122** in which an exposed area becomes an exposure area **S1** and a shielding part **124** formed at a shielding area **S2** of the mask substrate **122**.

The photo-resist is exposed by using the third mask **120** and developed, so that a photo-resist pattern **126** is formed at the shielding area **S2** corresponding to the shielding part **124** of the third mask **120**. The green resin **128** is patterned by an etching process using the photo-resist pattern **126**, therefore, a green color pattern **60G** and a green color pattern **54G** are formed as shown in FIG. **8C**. The green color pattern **54G** has a second hole **62b** overlapped with the first spacer hole **62a** and is formed so as to overlap with the red color pattern **54R**.

FIGS. **9A** to **9C** are sectional views illustrating a blue color filter of the upper array substrate of the liquid crystal display panel and a fabricating method of the blue color pattern according to the present invention.

Firstly, a blue resin **138** is entirely deposited on the upper substrate **51** on which the green color filter **60G** and the green color pattern **54G** are formed, as shown in FIG. **9A**. Subsequently, a photo-resist is entirely formed on the blue resin **138** and then a fourth mask **130** is aligned on the upper portion of the upper substrate **51** as shown in FIG. **9B**. The fourth mask **130** is made of a transparent substance and includes a mask substrate **132** in which an exposed area becomes an exposure area **S1**, and a shielding part **134** formed at a shielding area **S2** of the mask substrate **132**.

The photo-resist is exposed by using the fourth mask **130** and developed, so that a photo-resist pattern **136** is formed at the shielding area **S2** corresponding to the shielding part **134** of the fourth mask **130**. The blue resin **138** is patterned by an etching process using the photo-resist pattern **136**, therefore, a blue color pattern **60B** and a blue color pattern **54B** are formed as shown in FIG. **9C**. The blue color pattern **54B** has a third spacer hole **62c** overlapped with the first and the second spacer holes **62a** and **62b**, and is formed so as to overlap with the red and green color patterns **54R** and **54G**.

FIGS. **10A** to **10C** are sectional views illustrating a fabricating method of the common electrode and the spacer of the upper array substrate according to the present invention.

A transparent conductive material is deposited on the upper substrate **51** on which the color filter **60** and the color pattern **54** are formed by a deposition method such as sputtering, so that a common electrode **64** is formed as shown in FIG. **10A**. The common electrode is made of a

transparent conductive material including indium tin oxide ITO, indium zinc oxide IZO or indium Tin zinc Oxide ITZO.

Subsequently, an inkjet device **140** is aligned on the upper substrate **51** on which the common electrode **64** is formed. The inkjet device **140** spreads a spacer material **142** in the spacer hole **62** arranged by the color pattern **54** as shown in FIG 10B. The spacer material **142** spread in the spacer hole **62** is hardened at a designated temperature, so that a protruding spacer **54** is formed as shown in FIG. 10C.

FIG. 11 is a plan view representing an upper array substrate of a liquid crystal display panel according to a second embodiment of the present invention and FIG. 12 is a sectional view representing an upper array substrate taken along line II-II' in FIG. 11.

Referring to FIGS. 11 and 12, the upper array substrate of the liquid crystal display panel includes identical constituent elements except that a plurality of spacer holes is formed in comparison with the upper array substrate as shown in FIGS. 4 and 5.

The color pattern **54** is formed having a plurality of spacer holes **62**. The color pattern **54** has at least two color patterns, which are separate from each other, on the black matrix **52**. Herein, for example, an explanation of the color pattern **54** on which a red color pattern **54R**, a green color pattern **54G** and a blue color pattern **54B** are sequentially stacked will be made as follows. The red color pattern **54R** is formed to have a plurality of first spacer holes on the black matrix **52**. The green color pattern **54G** has a plurality of second spacer holes overlapped with a plurality of first spacer holes and formed to have a width identical to that of the red color pattern **54R** or a width smaller than that of the red color pattern **54R**. The blue color pattern **54B** has a plurality of third spacer holes overlapped with a plurality of second spacer holes and formed to have a width identical to that of the green color pattern **54G** or a width smaller than that of the green color pattern **54G**. Each of the red, the green and the blue patterns **54R**, **54G** and **54B** is formed a material identical to the red, the green and the blue color filters **60** at the same time.

After a spacer material is spread out in the spacer holes **62** having a plurality of spacer holes, the spacer is formed by hardening. The spacer **56** maintains the cell gap between the upper substrate and the lower substrate. Herein, an entire width of the spacer holes **62** is relatively narrower than an entire width of one spacer hole shown in FIGS. 4 and 5. Accordingly, a height of spacer filled in the spacer holes **62** is relatively higher than a height of a spacer filled in one spacer hole, using a spacer material of an identical amount.

As described above, the spacer of the liquid crystal display panel according to the second embodiment of the present invention is formed by filling the spacer material in the spacer hole arranged by the color pattern simultaneously formed with the color filter. Accordingly, the spacer is formed at a desired non-display area by forming the spacer at the spacer hole arranged by the color pattern overlapped with the black matrix. Further, a spacer may be formed with a height greater than the height of the color pattern by forming the spacer using the inkjet system at the spacer hole arranged by color pattern. Thus the cost of material can be reduced and process may be simplified.

On the other hand, the color pattern according to the present invention is formed in a dot unit and may be formed with a line shape to correspond to a gate line or a data line. Further, it has been explained that the color pattern according to the present invention is stacked in order of the red, green and blue color pattern but the color patterns may be stacked in any order, so that the color pattern is formed with

various types. In addition, the liquid crystal display panel according to the present invention is provided with the common electrode on the upper substrate to thereby be applicable to a twisted nematic (TN) mode having a vertical electric field with a pixel electrode formed on a lower substrate and an in-plane switching (IPS) mode having a horizontal electric field by forming the common electrode and the pixel electrode on the lower substrate.

As described above, according to a liquid crystal display panel and a fabricating method thereof, the spacer is formed to have a designated height by filling the spacer material in at least more than one spacer hole arranged by the color pattern simultaneously formed with the color filter. Accordingly, because a spacer material is spread in the spacer hole arranged by a color pattern overlapped with a black matrix by using an inkjet system, it is possible to achieve an accurate formation of the spacer. Therefore, it is possible that a spacer is formed at a desired non-display area. Further, it is possible that the spacer is formed with a height greater than the height of a color pattern by forming a spacer using an inkjet system at a spacer hole arranged by a color pattern. Thus, the costs of dedicated material may be reduced, and the fabricating process may be simplified.

Although the present invention has been explained by the embodiments shown in the drawings described above, it should be understood to the ordinary skilled person in the art that the invention is not limited to the embodiments, but rather that various changes or modifications thereof are possible without departing from the spirit of the invention. Accordingly, the scope of the invention shall be determined only by the appended claims and their equivalents.

What is claimed is:

1. A liquid crystal display panel comprising:
 - a black matrix on an upper substrate;
 - a color pattern having at least one hole on the black matrix;
 - a spacer protruding from the at least one hole, and a color filter at each area partitioned by the black matrix.
2. The liquid crystal display panel of claim 1, wherein the color pattern has a structure having at least two layers.
3. The liquid crystal display panel of claim 2, wherein the color pattern is formed by stacking a red color pattern, a green color pattern and a blue color pattern.
4. The liquid crystal display panel of claim 2, wherein a width of the color pattern narrows from an uppermost layer to a lowermost layer.
5. The liquid crystal display panel of claim 2, wherein the color pattern has an identical width in each layer.
6. The liquid crystal display panel of claim 1, wherein the color pattern has a width less than that of the black matrix.
7. The liquid crystal display panel of claim 1, further comprising a common electrode located between the color filter and the spacer.
8. The liquid crystal display panel of claim 1, wherein the spacer is formed by using an inkjet system.
9. A method of fabricating a liquid crystal display panel comprising:
 - forming a black matrix on a substrate;
 - forming a color filter at each area partitioned by the black matrix;
 - forming a color pattern having at least one hole on the black matrix; and
 - forming a spacer protruding from the at least one hole.
10. The method of claim 9, wherein the color pattern has a structure having at least two layers.

9

11. The method of claim **10**, wherein a width of the color pattern narrows from an uppermost layer to a lowermost layer.

12. The method of claim **10**, wherein the color pattern has an identical width in each layer.

13. The method of claim **9**, wherein the step of forming the color pattern includes:

- forming a red color pattern on the black matrix;
- forming a green color pattern on the red color pattern; and
- forming a blue color pattern on the green color pattern.

10

14. The method of claim **9**, wherein the color pattern is formed to have a width less than that of the black matrix.

15. The method of claim **9**, further comprising forming a common electrode located between the color filter and the spacer.

16. The method of claim **9**, wherein forming a spacer includes dispensing spacer material using an inkjet system.

* * * * *