

[54] **KNEE OSTEOTOMY BLADE** 2,702,550 2/1955 Rowe 128/317
 3,554,197 1/1971 Dobbie 128/317
 [75] Inventor: **Roy Paul Winter**, Santa Barbara, Calif. 3,678,934 7/1972 Warfield et al. 128/317

[73] Assignee: **American Sterilizer Company**, Erie, Pa.

Primary Examiner—Channing L. Pace
Attorney, Agent, or Firm—Lyon & Lyon

[22] Filed: **Jan. 28, 1974**

[57] **ABSTRACT**

[21] Appl. No.: 437,174

A knee osteotomy blade comprises a flat metal arm tapered symmetrically from a hub at one end to a cutting head at the other. A spline driver fixed to the hub extends in one direction therefrom and serves to oscillate the arm about the axis of the spline driver. The cutting head has an arcuate series of teeth, a half-tooth being provided at each end of said series to facilitate cutting of a blind groove, alternate teeth in the series being set in opposite directions to produce a groove wider than the thickness of the cutting head.

[52] U.S. Cl. 128/317; 30/166 R; 83/782; 83/835; 83/848

[51] Int. Cl.² A61B 17/14; B27B 33/02

[58] Field of Search 128/317; 30/166 R; 83/782, 83/835, 848

[56] **References Cited**
UNITED STATES PATENTS
 2,455,655 12/1948 Carroll 128/317

2 Claims, 4 Drawing Figures

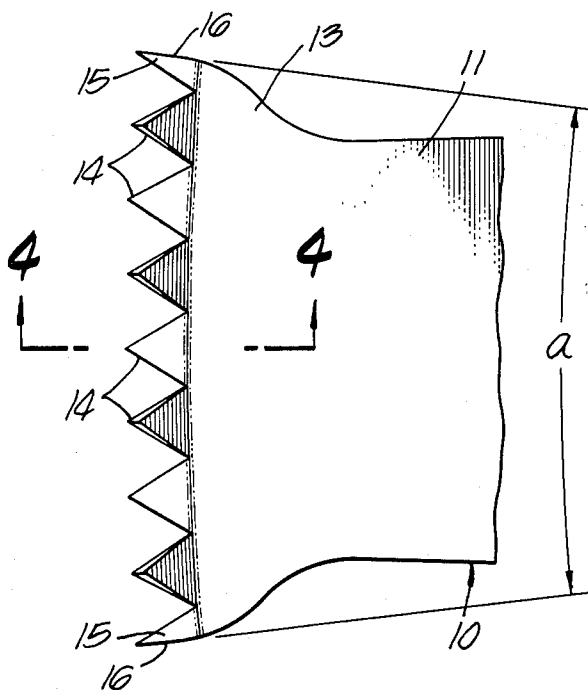

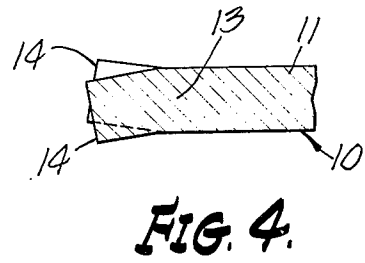
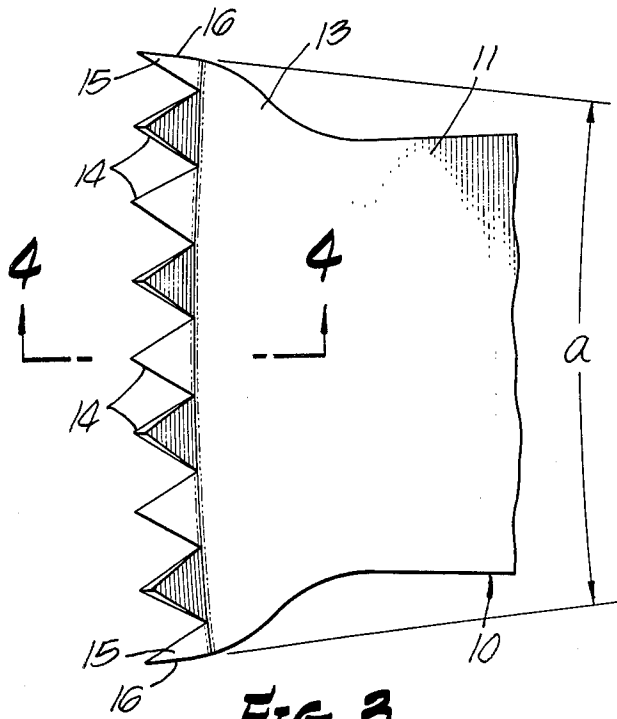
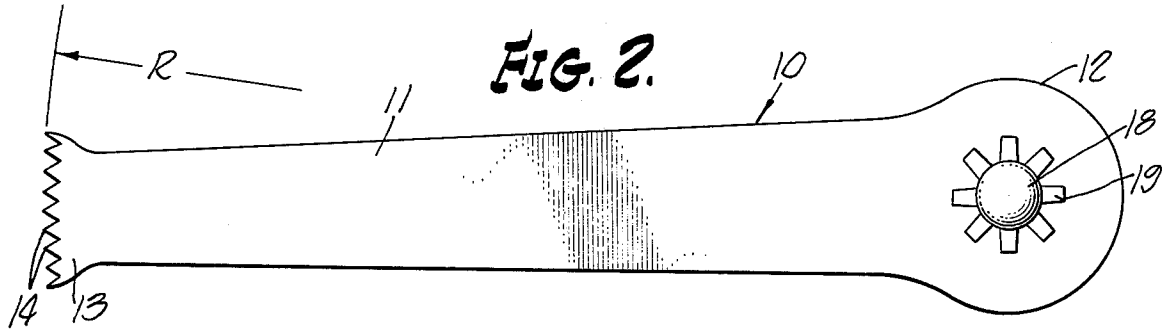
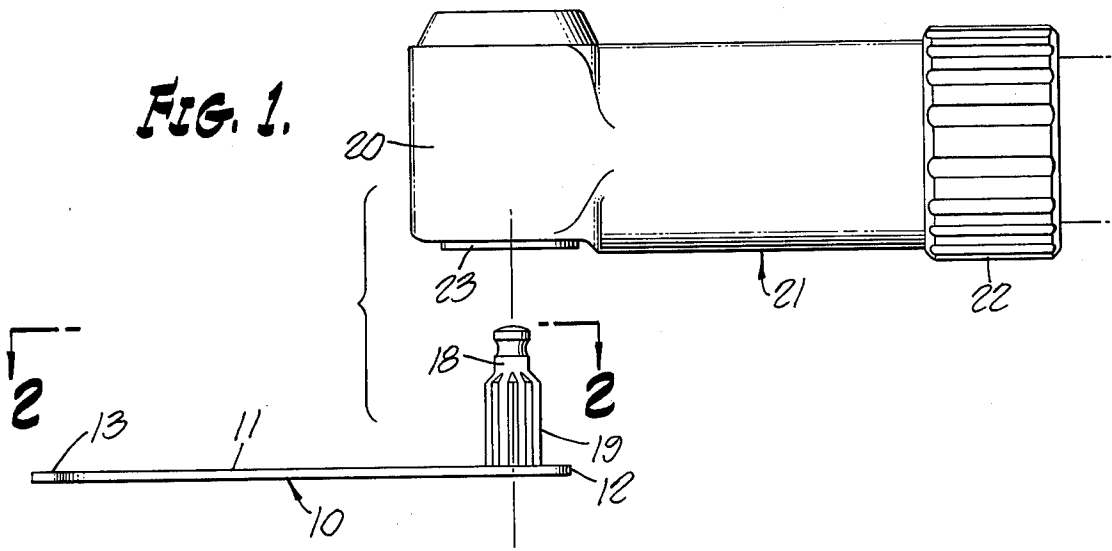

KNEE OSTEOTOMY BLADE

BACKGROUND OF THE INVENTION

This invention relates to power driven surgical tools and is particularly directed to an osteotomy saw blade for cutting a blind groove in the human femur for the polycentric type total knee operation. The configuration of the knee blade greatly improves the cutting ability in a blind groove without binding or stalling.

Cutting of a blind groove, that is, a groove which has full depth up to its end shoulder, is difficult to accomplish during an operation on the femur because the bone cuttings tend to pack at the end of the groove. The operation takes place under moist conditions and it is difficult to remove the bone cuttings from the end of the groove while the cutting action is taking place.

It is an important object of this invention to provide a novel form of osteotomy knee blade which overcomes this difficulty.

In accordance with this invention, the cutting head of the blade is carried on an arm which is oscillated in a small arc in a back and forth motion, cutting teeth are provided on the head in an arcuate series and a half-tooth is formed at each end of the series. The outer face of each half-tooth is shaped to prevent packing of bone cuttings at the end of the groove. All of the teeth in the series are "set" in opposite directions to produce a groove wider than the thickness of the cutting head.

Other and more detailed objects and advantages will appear hereinafter.

In the drawings

FIG. 1 is a side elevation showing a knee osteotomy blade embodying this invention and also showing an attachment for a rotary power tool, which attachment is used to oscillate the knee blade.

FIG. 2 is an enlargement taken substantially on the Line 2-2 as shown in FIG. 1.

FIG. 3 is an enlargement of the cutting head and arcuate series of teeth, showing the half-tooth at each end of the series and also showing that alternate teeth in the series are "set" in opposite directions.

FIG. 4 is a sectional detail taken substantially on the Line 4-4 as shown on FIG. 3.

Referring to the drawings, the osteotomy knee blade generally designated 10 comprises a flat metal arm 11 which is tapered symmetrically from an enlarged hub 12 to a cutting head 13. The cutting head 13 is wider than the adjacent portion of the arm 11, and it is provided with an arcuate series of cutting teeth 14. The pointed ends of the teeth lie in an arc having a radius R struck from the axis of the splined driver 18. As

shown in FIGS. 3 and 4, alternate teeth in the series are "set" in opposite directions to produce a groove wider than the thickness of the cutting head 13. A half-tooth 15 is formed at each end of the series. The outer surfaces 16 of the half-tooth 15 define an acute angle *a* between them.

A driver 18 having external splines 19 is fixed to the arm 11 centrally of the hub 12 and projects from one side thereof. This spline driver 18 is adapted to be received within a splined socket provided in one end 20 of an oscillator tool 21. A rotary nut 22 on the other end of the oscillator tool operates a collet chuck to receive one end of a stationary part of a rotary power tool, not shown. A mechanism within the device 21, not shown, converts the rotary movement of the power tool to oscillatory turning movement of the output socket 23. The arm 11 oscillates in a plane about the axis of the spline driver 18 and it moves a few degrees of arc sufficient to cause several teeth 14 to oscillate past the same spot in the groove being cut.

Bone cuttings do not pack at the blind ends of the groove because the teeth 15 at the ends of the series of teeth are only half-tooth in width. Moreover, the end surfaces 16 are undercut as shown by the angle *a*.

Having fully described my invention, it is to be understood that I am not to be limited to the details herein set forth but that my invention is of the full scope of the appended claims.

I claim:

1. A blade of the type described, comprising a metal arm extending from a hub at one end to a cutting head at the other end, a driver fixed to the hub for oscillating the arm in a plane about the axis of the driver, the cutting head having an arcuate series of teeth, to cut a groove, a half-tooth being provided at each end of said series, the outer surface of each half-tooth being undercut to prevent packing of cuttings at blind ends of the groove being cut.

2. A blade of the type described, comprising a flat metal arm tapering from a hub at one end to a cutting head at the other end, a spline driver fixed to the hub for oscillating the arm in a plane about the axis of the spline driver, the cutting head having an arcuate series of teeth, alternate teeth in the series being set in opposite directions to produce a groove wider than the thickness of the cutting head, a half-tooth being provided at each end of said series, the outer surface of each half-tooth being undercut to prevent packing of cuttings at blind ends of the groove being cut.

* * * * *

55

60

65