



US 20010037053A1

(19) **United States**

(12) **Patent Application Publication**  
**Bonadio et al.**

(10) **Pub. No.: US 2001/0037053 A1**

(43) **Pub. Date: Nov. 1, 2001**

(54) **SURGICAL DEVICE FOR RETRACTING AND/OR SEALING AN INCISION**

(30) **Foreign Application Priority Data**

(76) Inventors: **Frank Bonadio**, Bray (IE); **Shane Joseph McNally**, Dublin (IE); **Ronan Bernard McManus**, Bray (IE); **Derek William Young**, Blackrock (IE); **Alan Reid**, Dublin (IE)

Dec. 1, 1998 (IE)..... 980997  
Feb. 15, 1999 (IE)..... 990111

**Publication Classification**

(51) **Int. Cl.<sup>7</sup>** ..... **A61B 17/02**  
(52) **U.S. Cl.** ..... **600/208; 600/235**

Correspondence Address:  
**Finnegan, Henderson, Farabow,  
Garrett & Dunner, L.L.P.**  
1300 I Street, N.W.  
Washington, DC 20005-3315 (US)

(57) **ABSTRACT**

(21) Appl. No.: **09/801,826**

(22) Filed: **Mar. 9, 2001**

**Related U.S. Application Data**

(63) Continuation of application No. PCT/IE99/00122, filed on Dec. 1, 1999.

A wound protector retractor comprises an inner O-ring for insertion through a wound opening and a connecting sleeve extending between the O-ring and outer mounting assembly. The outer assembly is provided by rings between which the sleeve is led. The rings are rotated relative to each other and the inner ring to form a centralized lumen of reduced cross section and to shorten the axial extent of the sleeve. A wound is both retracted and protected.

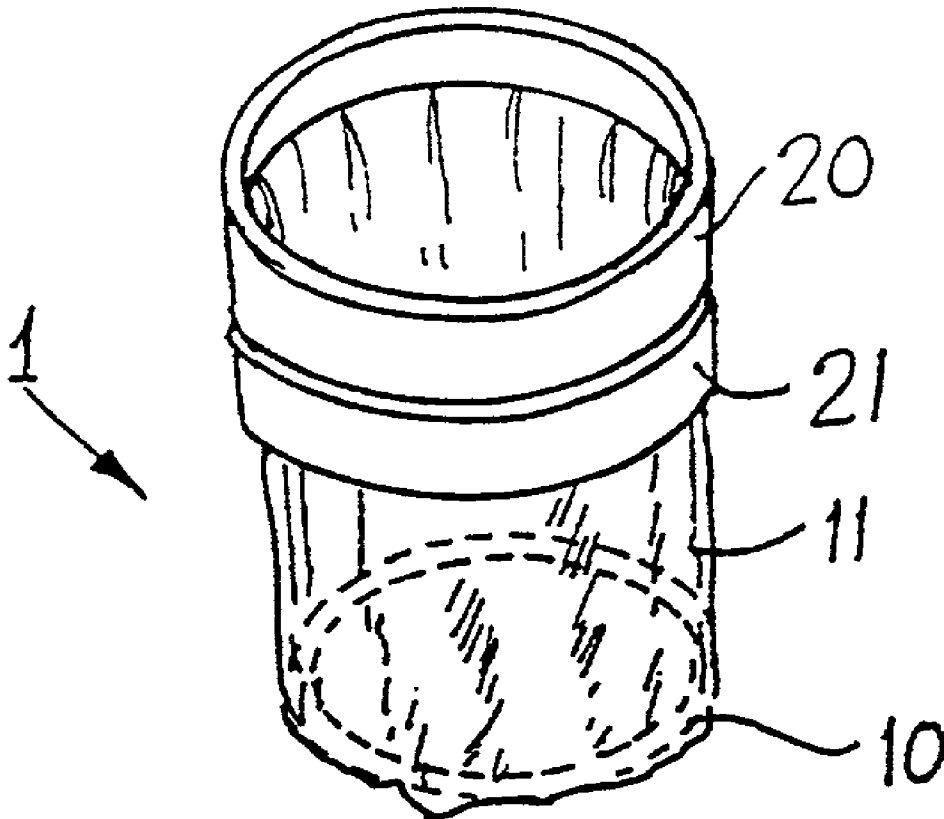

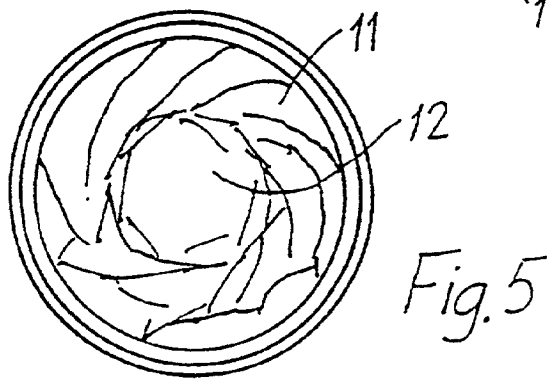
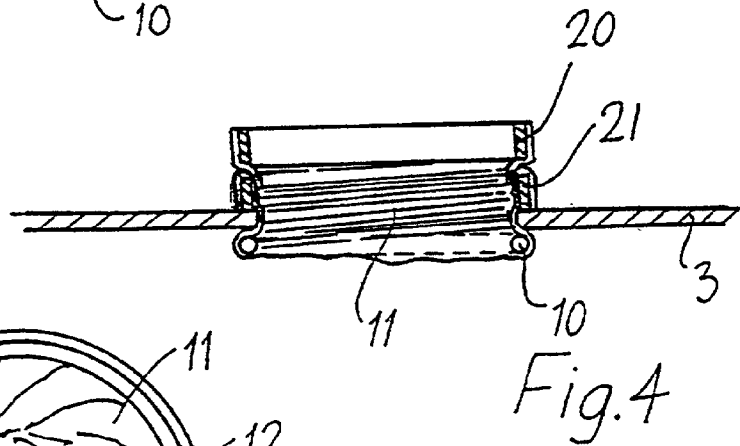
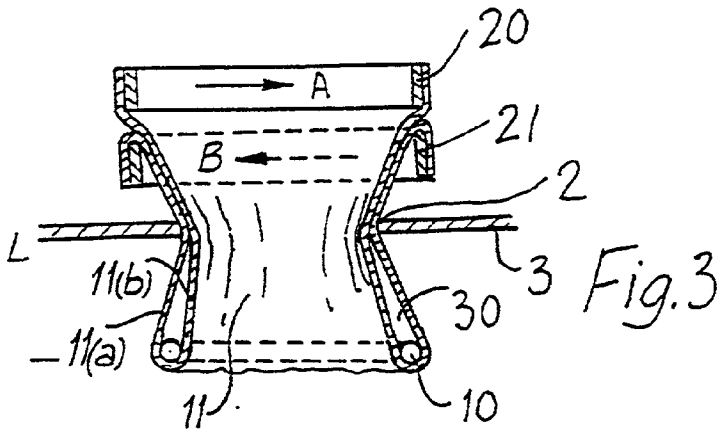
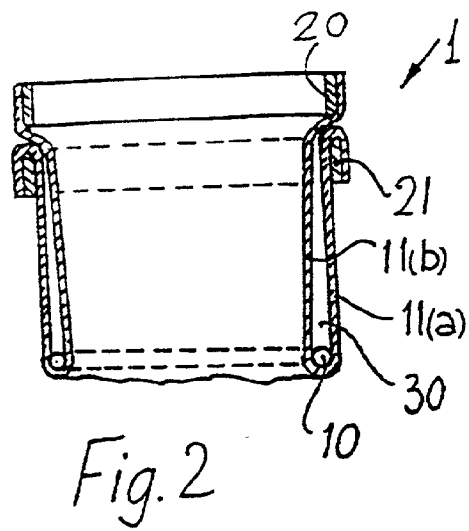
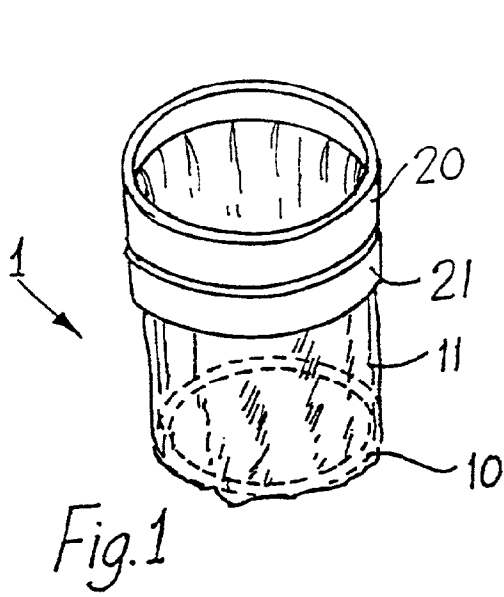

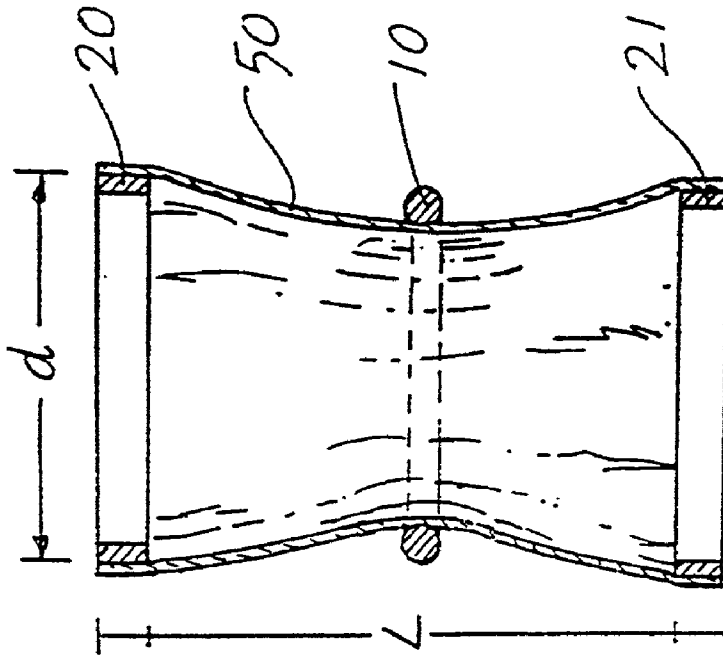

Fig. 7

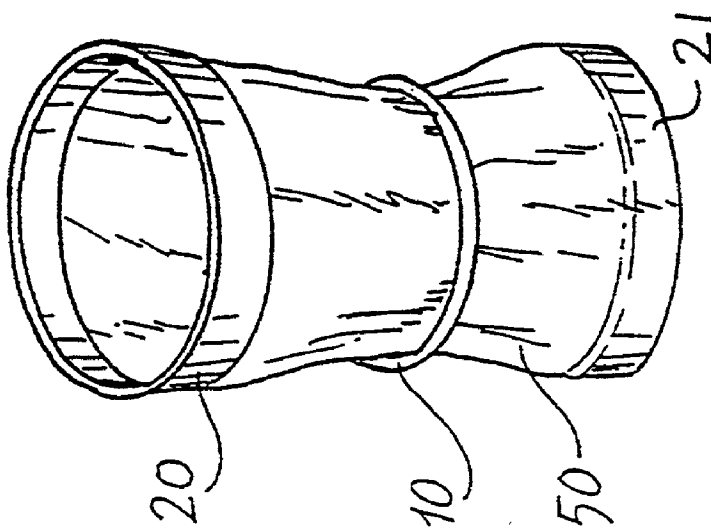
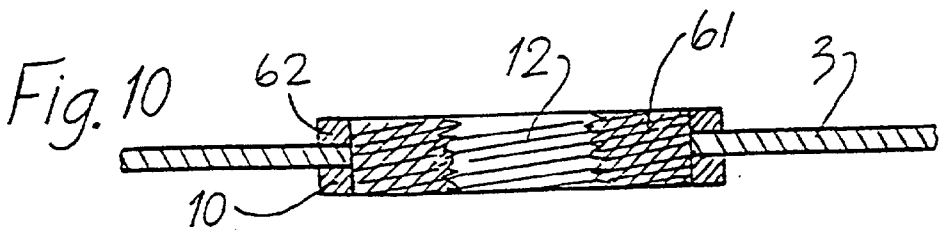
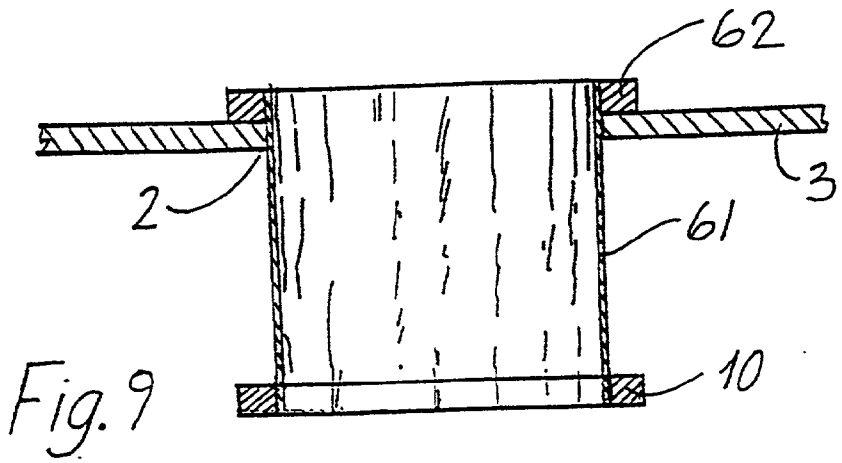
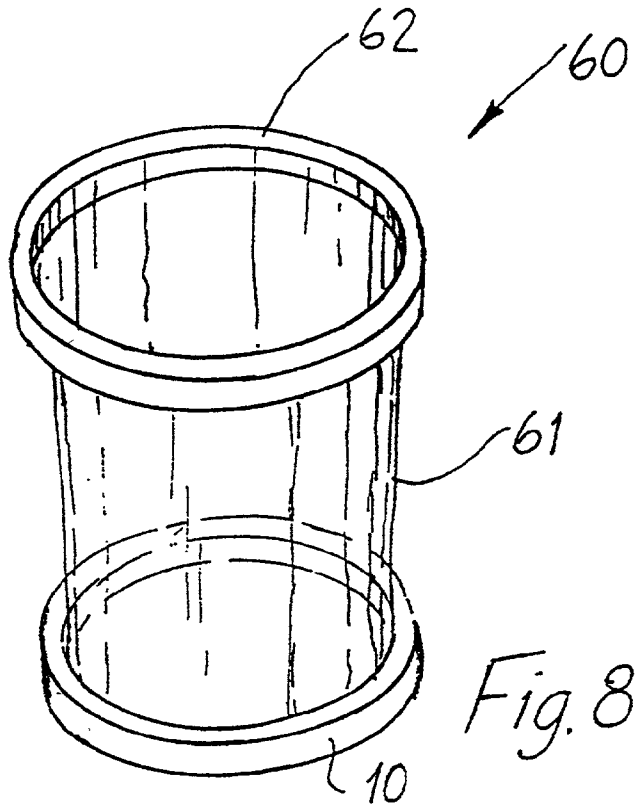

Fig. 6



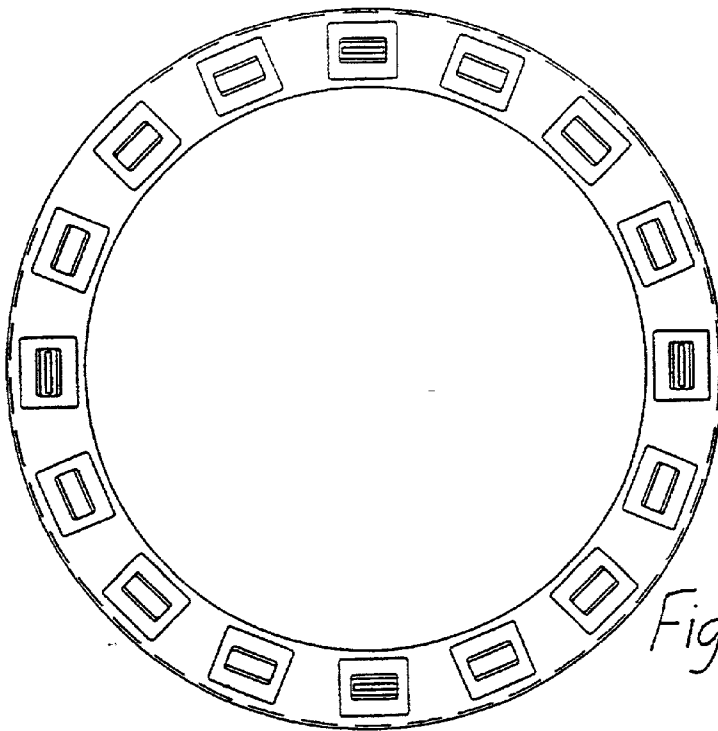

Fig. 13

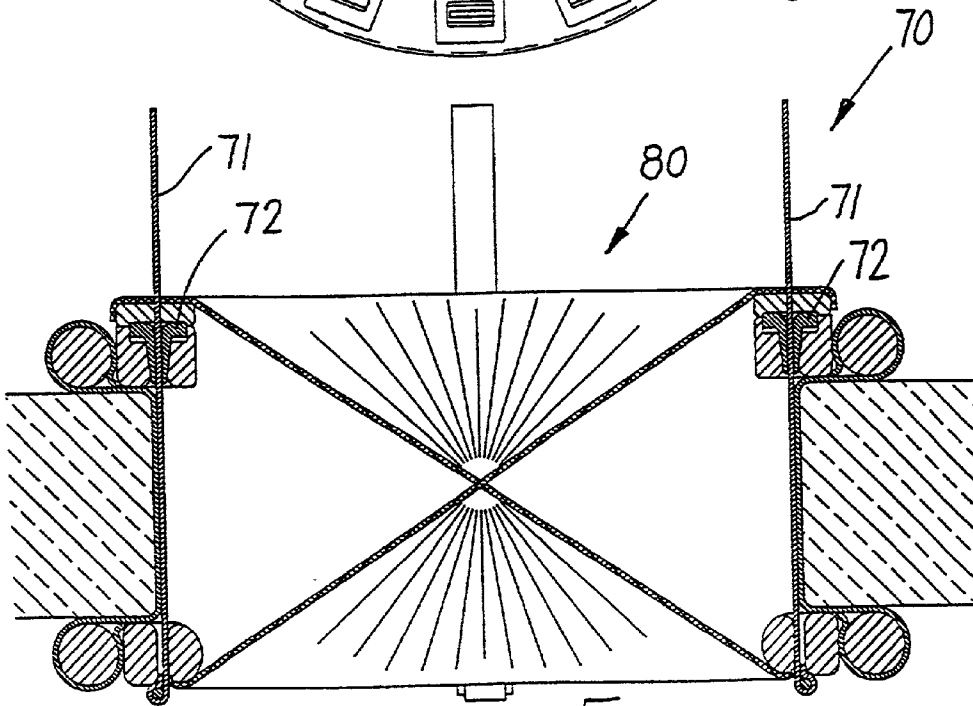

Fig. 11

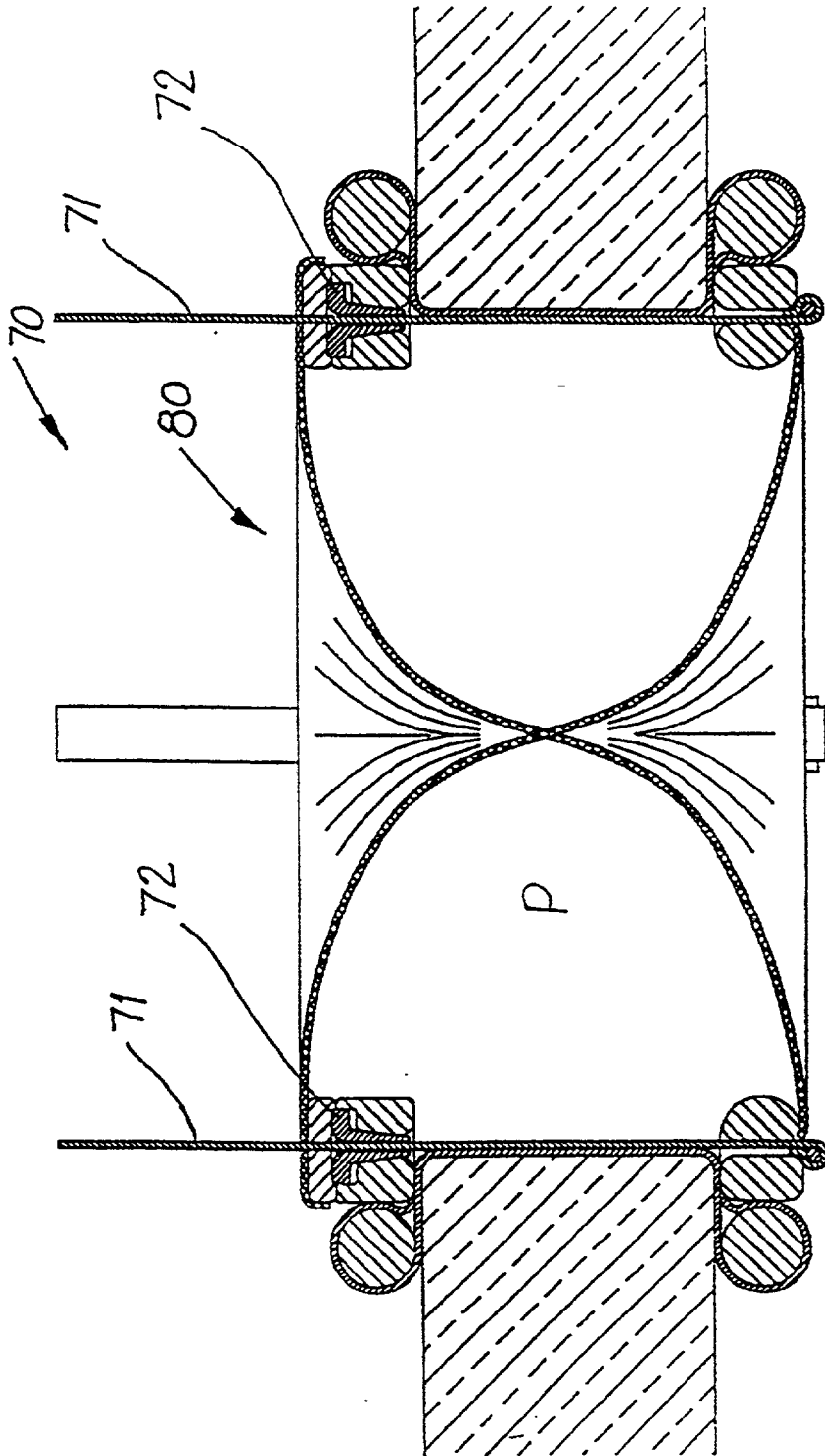

Fig.12

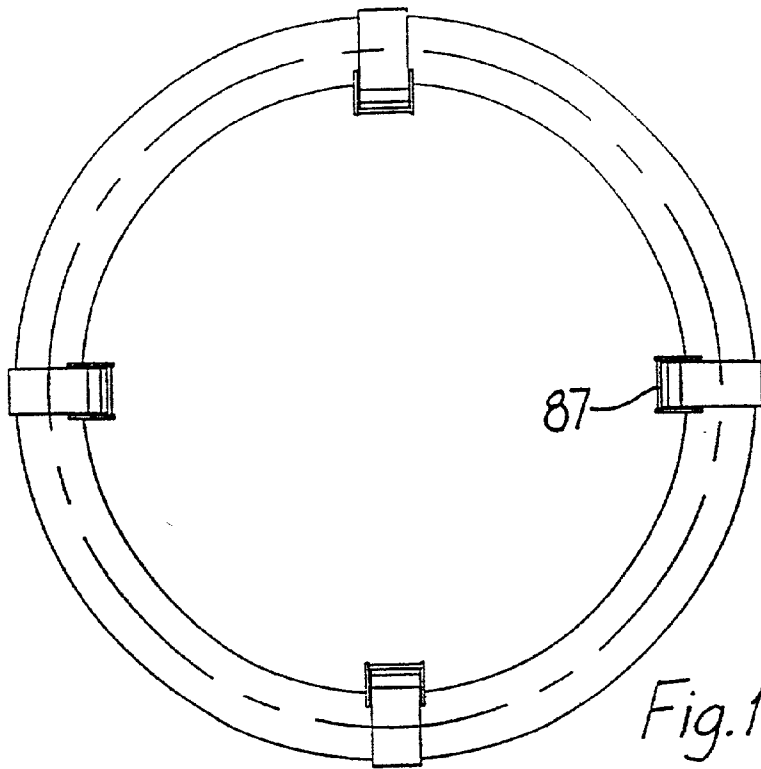

Fig. 16

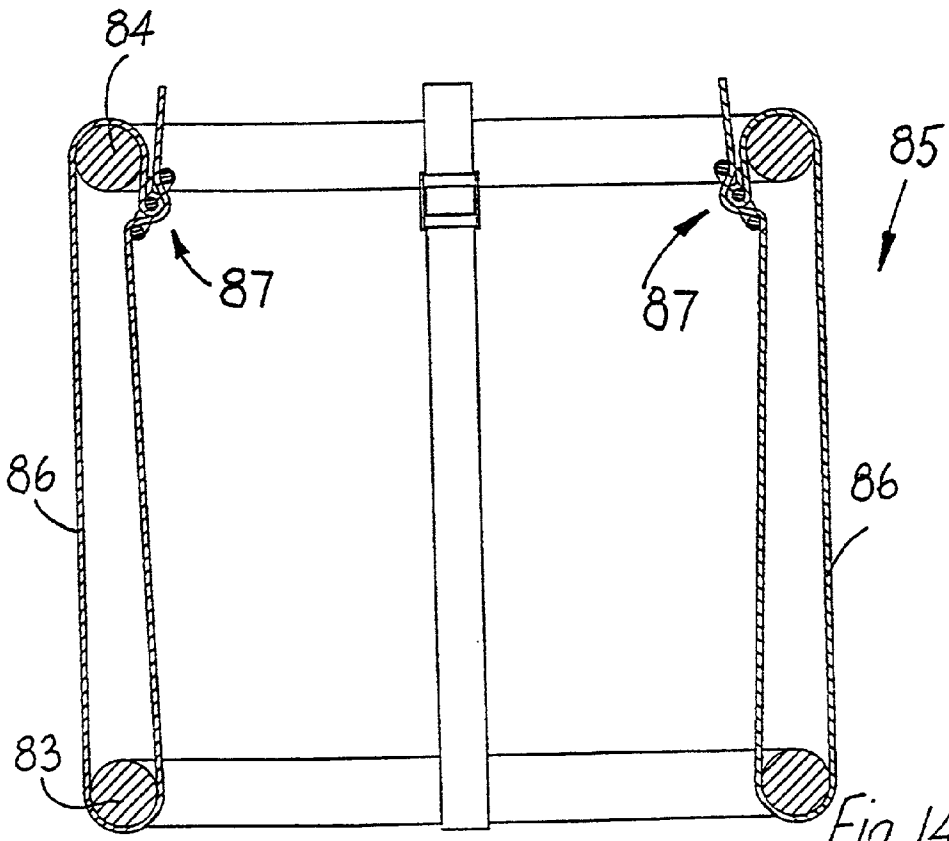
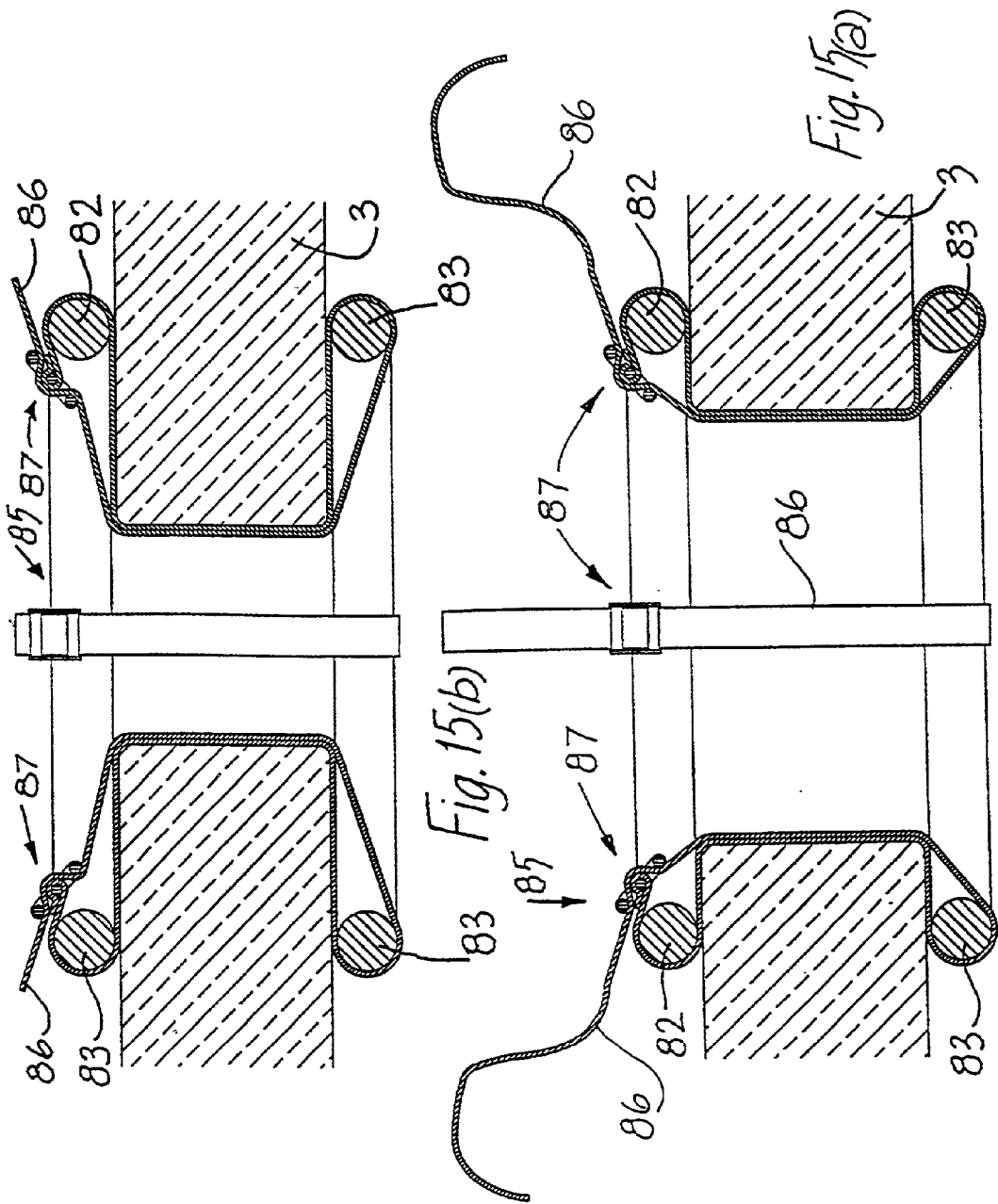
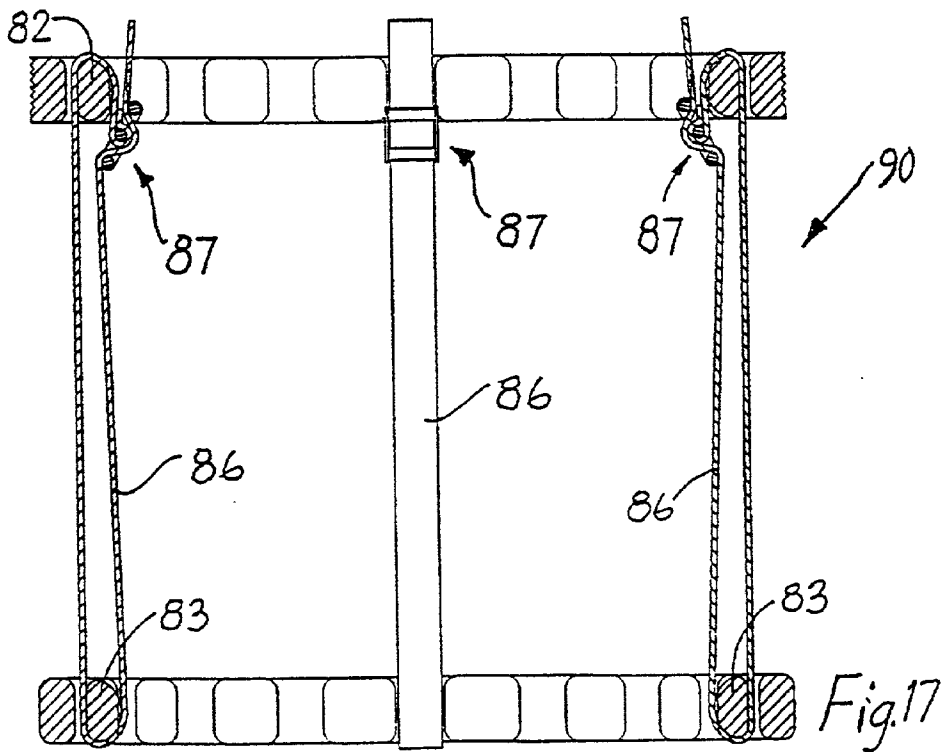
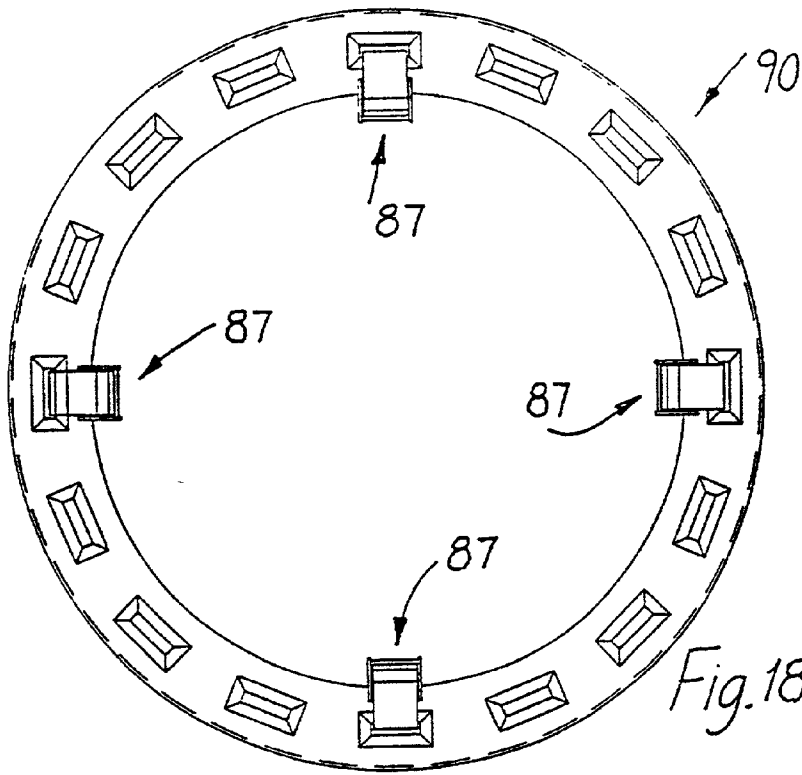
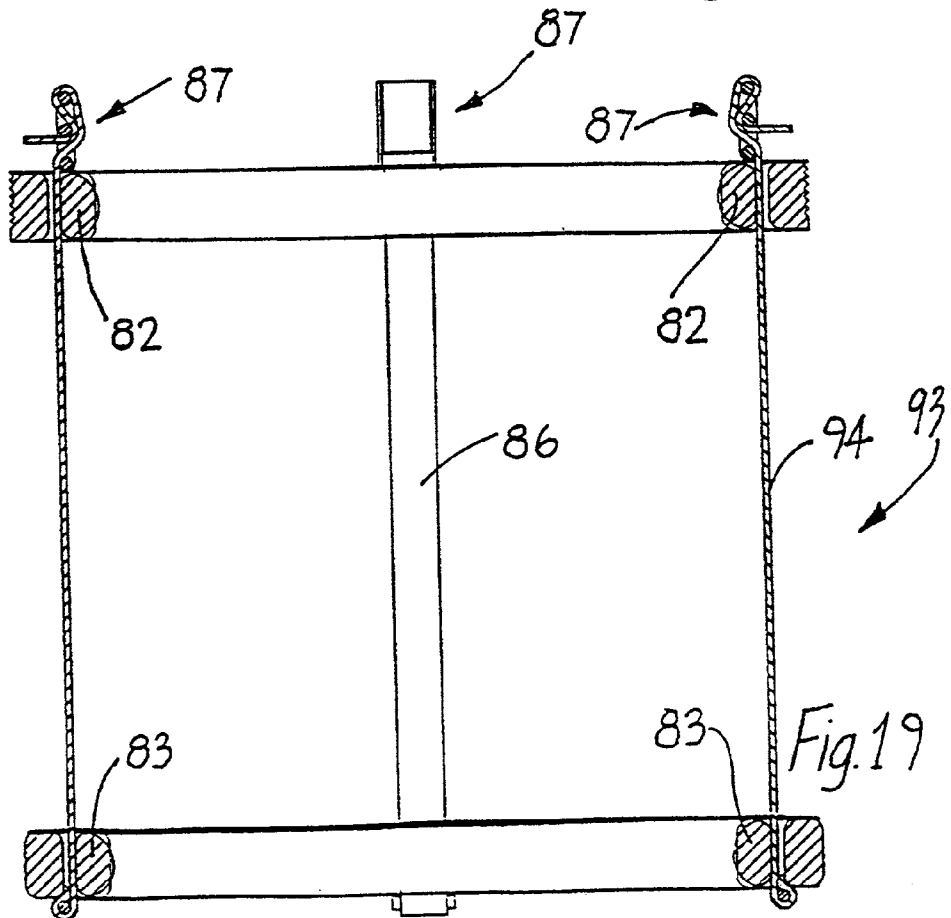
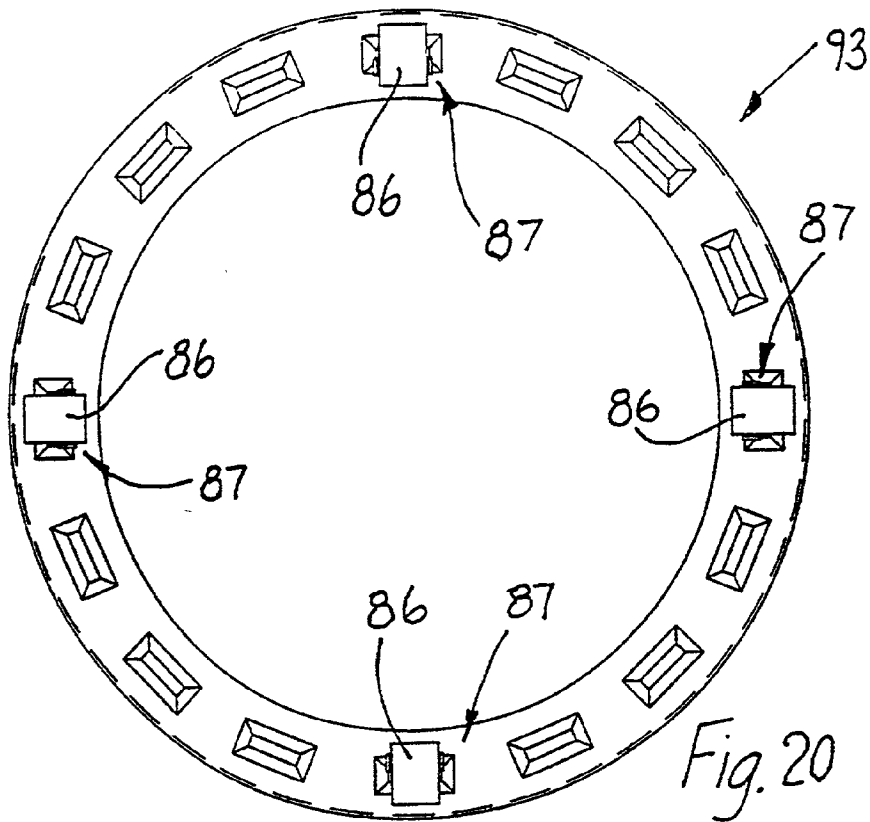

Fig. 14









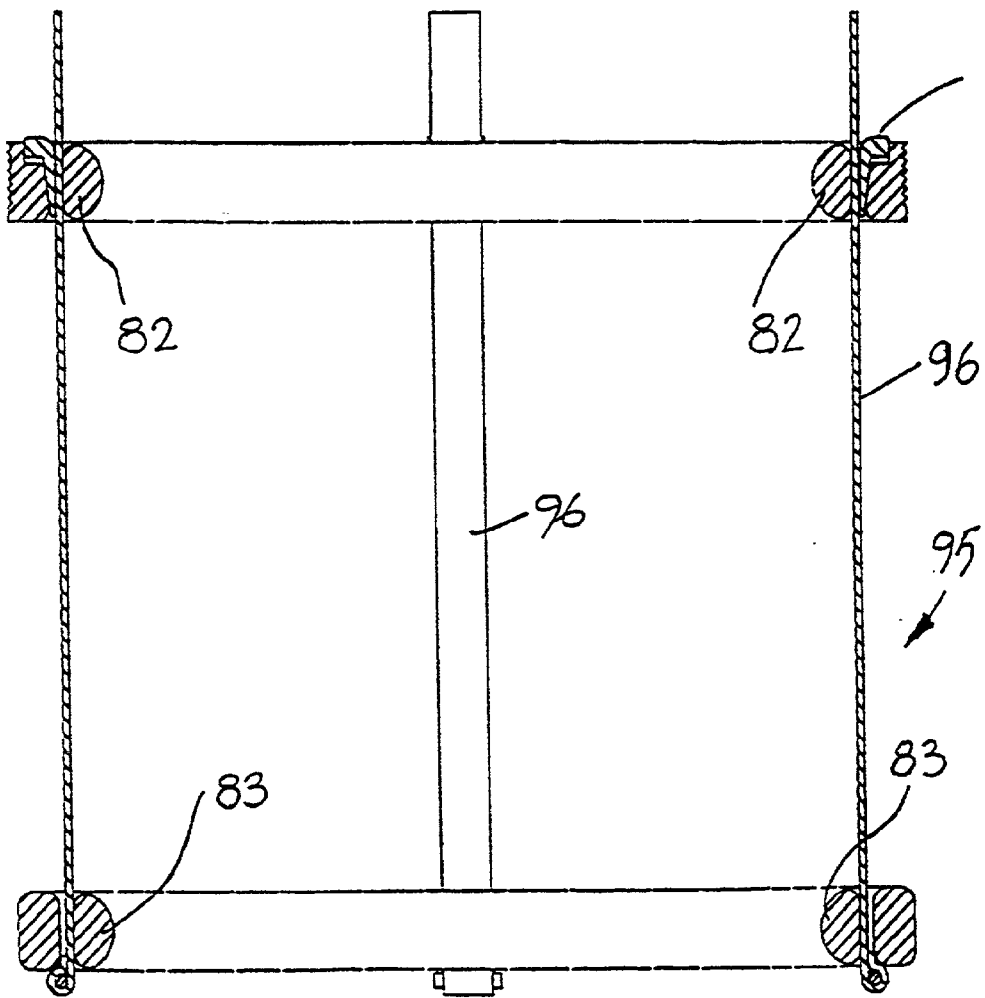
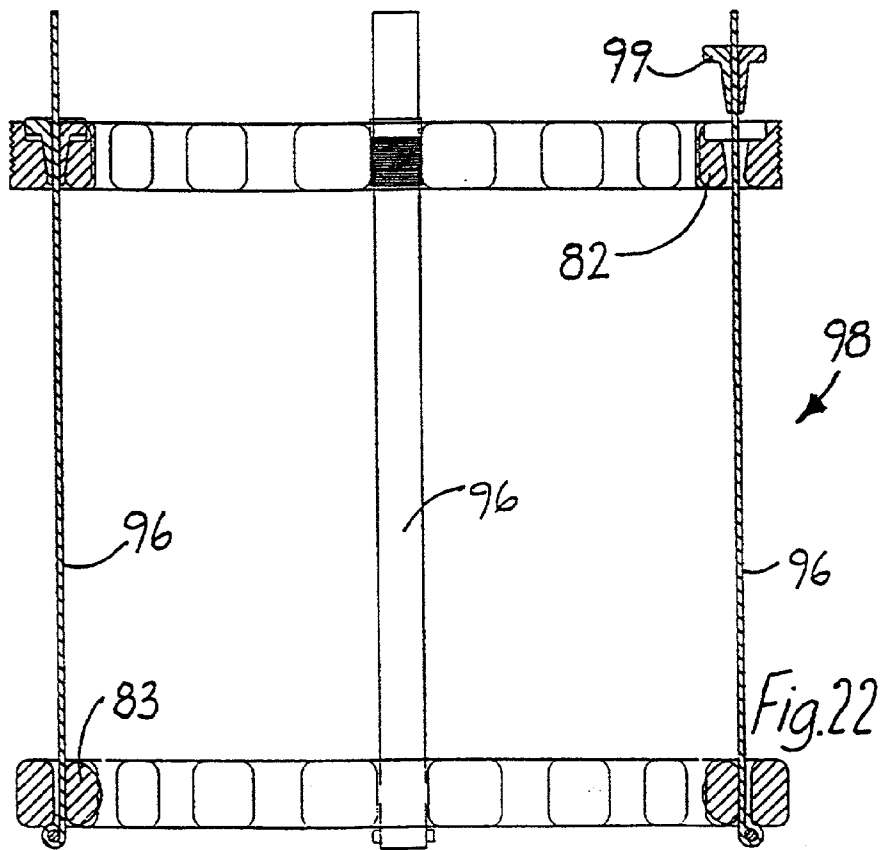
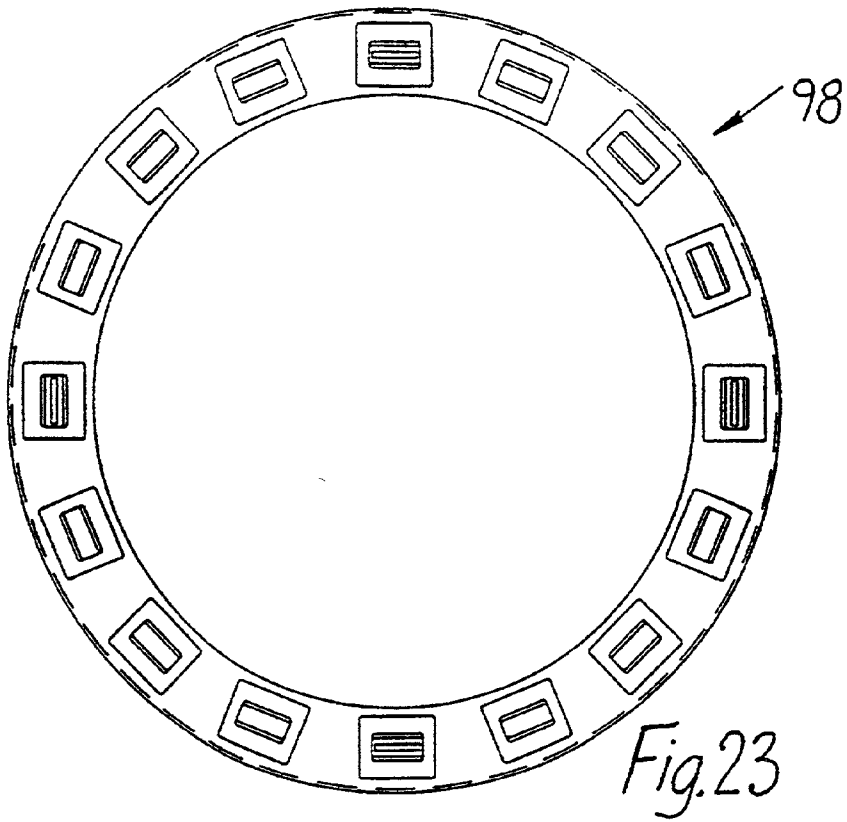

Fig. 21



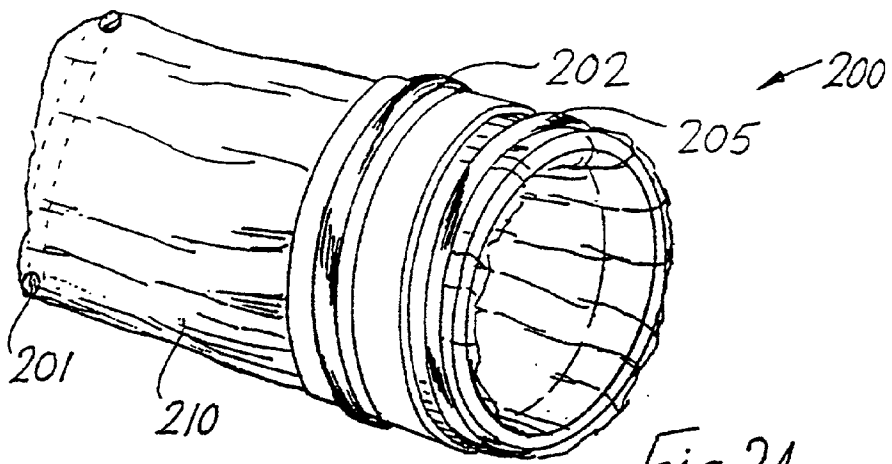

Fig. 24

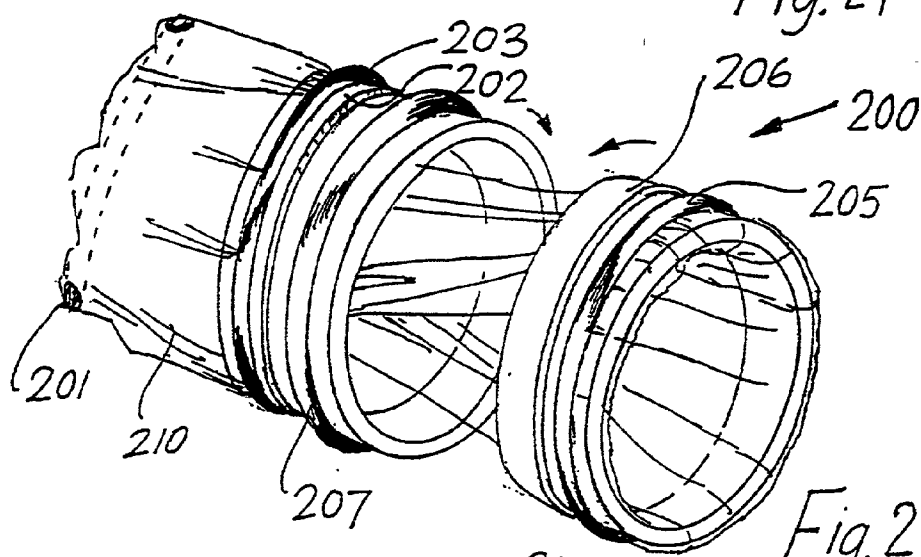

Fig. 25

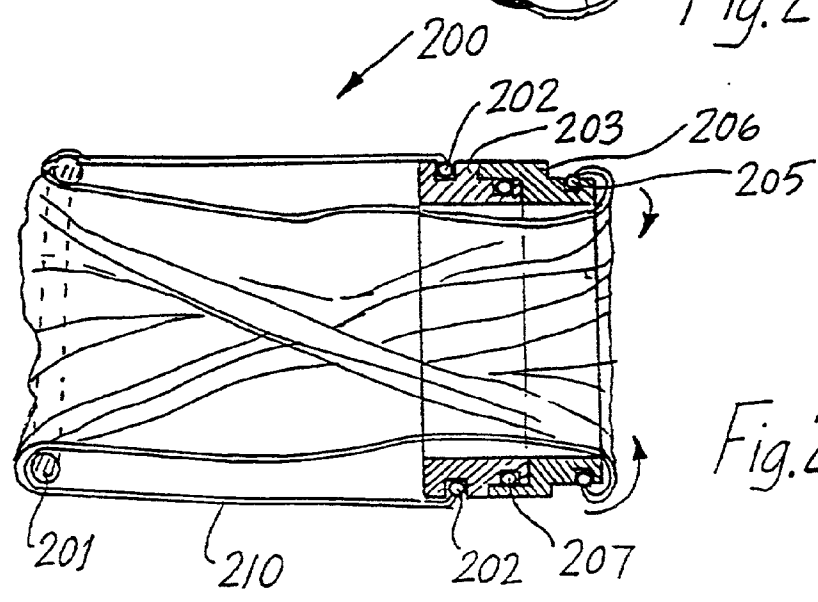
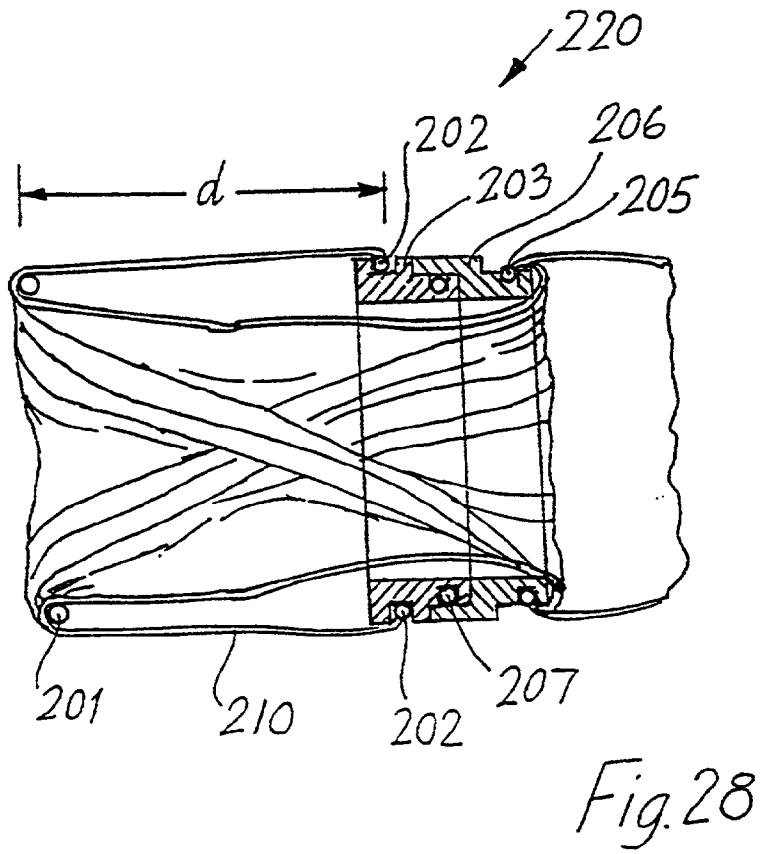
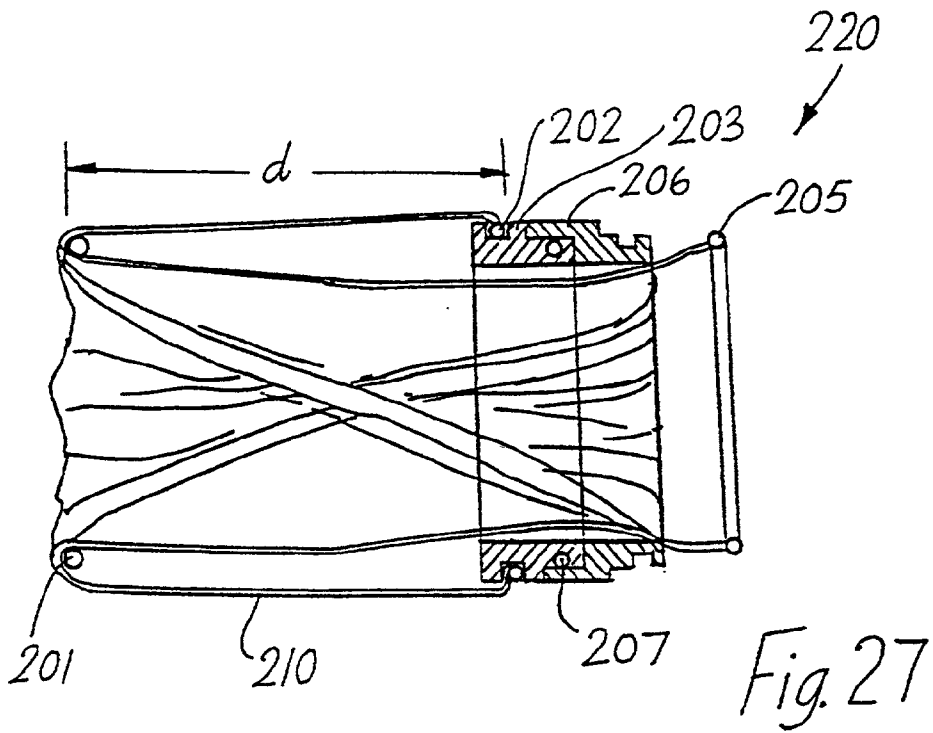

Fig. 26



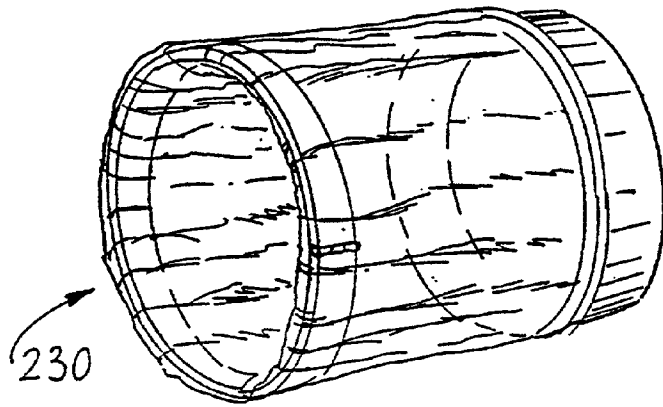

Fig. 29

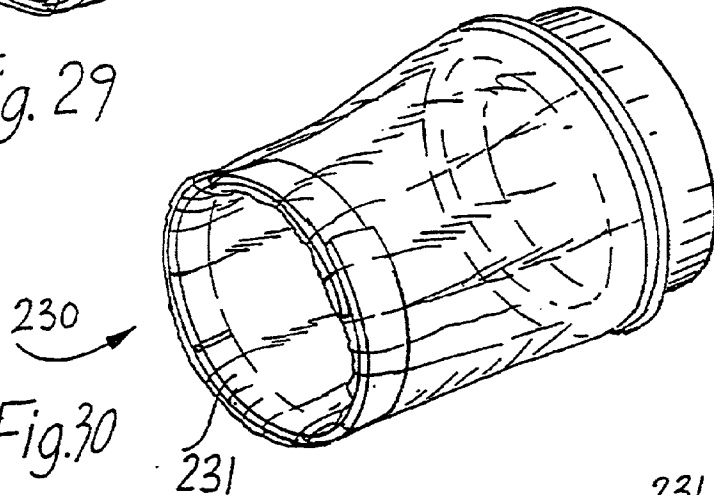

Fig. 30

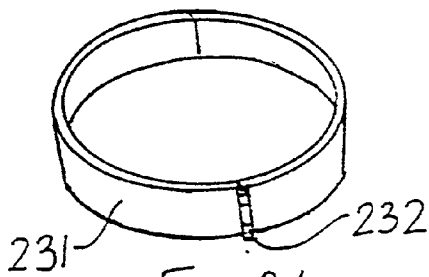

Fig. 31

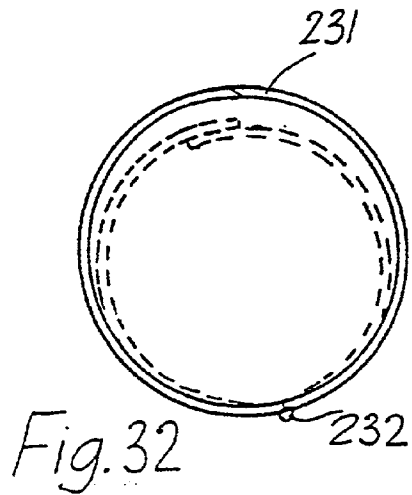
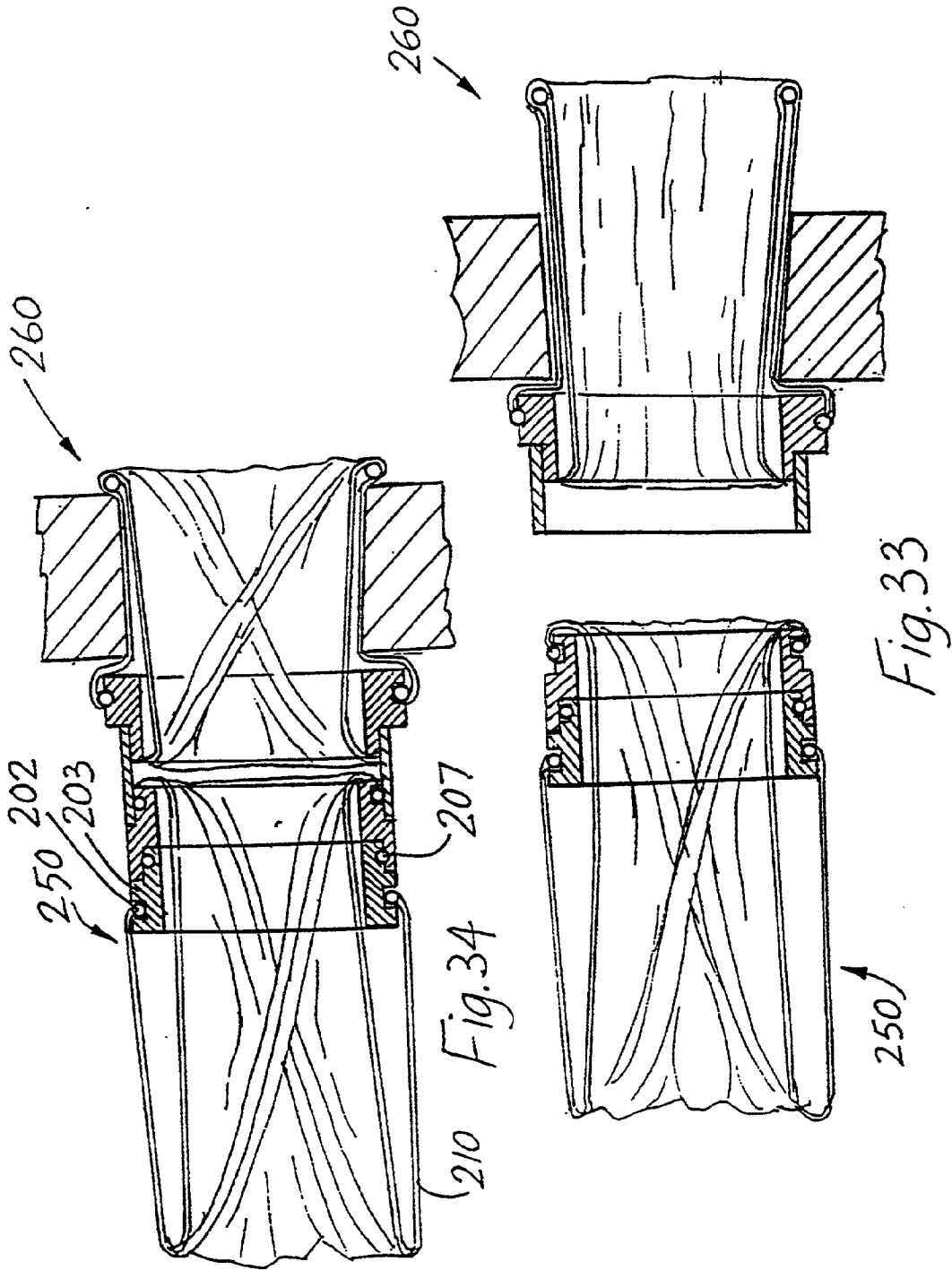

Fig. 32





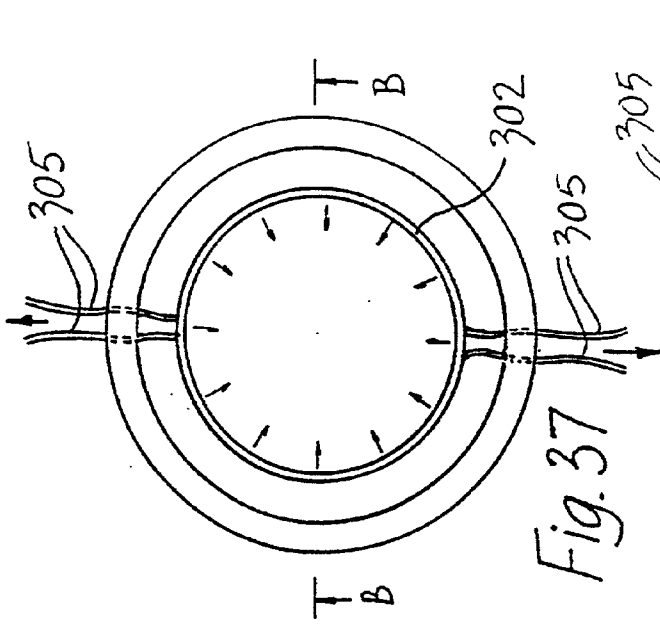

Fig. 37

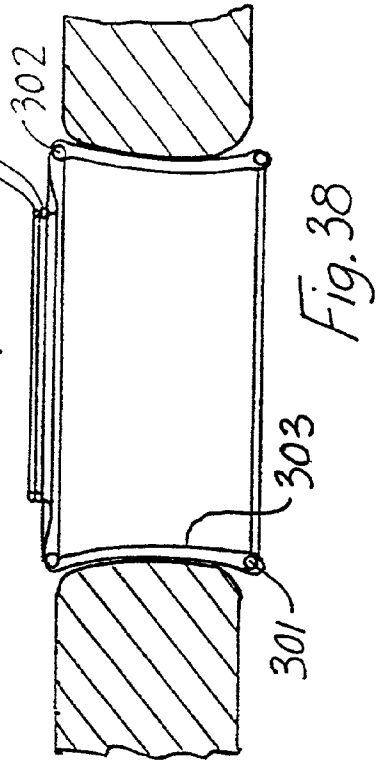

Fig. 38

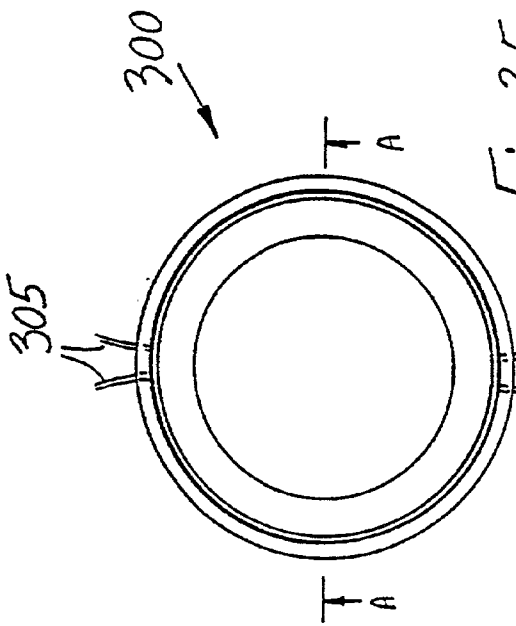

Fig. 35

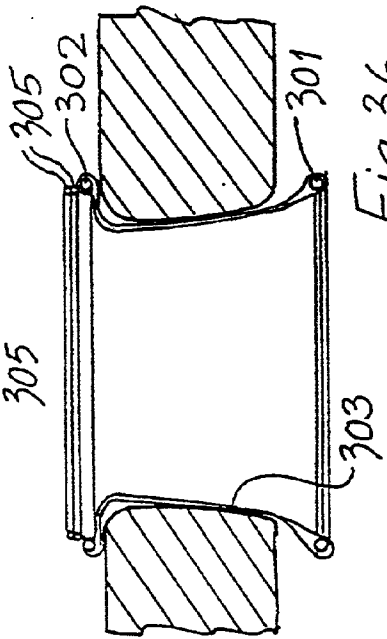

Fig. 36

## SURGICAL DEVICE FOR RETRACTING AND/OR SEALING AN INCISION

### BACKGROUND OF THE INVENTION

[0001] The present invention relates to a surgical device. More specifically, the invention relates to devices for retraction of an incision or natural bodily opening during surgery and for protecting the edges or incisions from infection or tumour seeding during surgery.

#### Wound Retraction

[0002] Adequate anatomical exposure is required in modern surgical procedures to allow procedures to be safely and effectively performed. Anatomical exposure is achieved by separating the walls of a natural orifice or spreading apart the margins of a surgical incision. A difficult surgical procedure can be simplified by adequate retraction whereas a relatively simple procedure can be made more difficult or even dangerous by the lack of adequate retraction. Exposure is maximised with correct incision placement and well directed retraction.

[0003] Retraction can be achieved in several different ways. The most common method of surgical wound retraction is by the use of hand held retractors. These may be made of metal or thermoplastics and allow an operator to apply a retraction force to the wound edges. They are disposable or reusable and come in a variety of shapes and sizes to satisfy the requirements of different surgical procedures.

[0004] Another type of retractor are Frame mounted retractor devices are also known. Such devices consist of a rigid circular or horseshoe-shaped frame on which multiple, detachable and movable paddle retractors are attached. The device may be mounted to an operating table to provide secure anchorage. Retraction may be applied in required directions. Typically such retractors are made of stainless steel to facilitate cleaning and sterilisation for reuse. Some of the more complex retractors need to be taken apart before sterilisation and reassembled before use. These devices always apply retraction at a few specific locations on the wound. This is a disadvantage of such devices as it can lead to regional ischaemia on parts the wound edge.

[0005] A wound retractor and protector is disclosed in U.S. Pat. No. 5,524,644 (Crook). This device consists of an open-ended sleeve of polymeric material with a flexible ring at each end. One ring is inserted into the incision and the sleeve is manually rolled up around the other ring to apply tension to the polymeric material to achieve retraction. The device is often difficult to use because of the manual dexterity required, especially when the surgeons hands are wet. In addition, the device is incrementally adjustable. This restricts the efficiency of the device across all abdominal wall thicknesses.

[0006] U.S. Pat. No. 5,545,179 (Williamson IV) describes a device having an elastomeric sealing element and a tubing conduit. The device protects the edges of the wound from contamination. However, the device is specifically for laparoscopic instruments and is not suitable for hand assisted surgery because the wound opening is not sufficiently retracted.

[0007] WO-A-96/36283 (Mollenauer) describes a trocar device for retracting and sealing an incision and providing a

sealed access port for surgical instruments. Whilst this incision and providing a sealed access port for surgical instruments. Whilst this device provides both retraction and protection to the wound edge is not suitable for use in hand assisted surgery due to size limitations. The device retracts and protects due to the inflation of one or one or more balloons and because these close the lumen when inflated it is not possible to visualise the contents of the abdomen through the device.

[0008] WO-A-98/48724 discloses a device for use in hand assisted laparoscopic surgery. The device has a wound retractor/protector component and a component for sealing around the wrist of the surgeon. The wound protector component consists of an inner ring and two outer inflatable doughnut-shaped rings mounted vertically on top of another. The inner and outer rings are linked by an elastomeric sleeve. Inflation of the two outer rings causes retraction of the elastomeric sleeve. This device provides wound retraction and protection but it is not suitable for device has a large vertical profile due to the outer rings. This restricts reach into the incision and extends the fulcrum of any instruments used in such a way that their effective reach and breath of lateral movement would be severely restricted.

#### Wound Protection

[0009] The sides of an open wound are susceptible to infection and cross contamination if they are touched by contaminated material such as body parts or fluids as they pass through the opening of a wound. Serious problems can also result from cancerous material coming into contact with the wound edge. It is well known that cancerous cells may become seeded in wound areas, especially at trocar sites.

[0010] To avoid such problems great care is taken to protect the edges of an incision using drapes that are impervious to liquids. An incision liner is disclosed in U.S. Pat. No. 3,397,692 (Creager). This liner comprises a sheet of polymeric material. The sheet has a hole cut out in the center and the edges of the hole are reinforced using a semi-rigid ring. This ring can be inserted into the incision allowing a surgical procedure to proceed through the ring while the material attached to the ring protects the edges of the incision from contaminants in the wound site. These devices marketed as "Steridrape" by 3M Corporation and comes in a variety of sizes for different wound sizes. However such devices do not adequately retract an incision.

[0011] In general known devices are of either complex construction, do not effectively seal a wound and/or are difficult to operate.

[0012] There is therefore a need for an improved surgical device that will overcome at least some of these problems.

### STATEMENTS OF INVENTION

[0013] According to the invention there is provided a surgical device comprising:

[0014] an inner mounting means for insertion through a wound opening;

[0015] a first outer mounting means for mounting external of a wound opening; and

[0016] connecting means extending between the inner and outer mounting means;

- [0017] the connecting means being movable to shorten the axial extent of the connecting means.
- [0018] In a particularly preferred embodiment of the invention the outer mounting means is movable relative to the inner mounting means to twist the connecting means to form a lumen of reduced cross section and to shorten the axial extent of the connecting means.
- [0019] Most preferably the outer mounting means is rotatable relative to the inner mounting means to twist the connecting means.
- [0020] In a particularly preferred embodiment of the invention the connecting means is a sleeve of pliable material extending between the inner and outer mounting means.
- [0021] In one aspect the device includes a second outer mounting means, the connecting means extending between the first outer mounting means, the inner mounting means, and the second outer mounting means.
- [0022] In this case preferably the first and second outer mounting means are rotatable relative to one another to twist the connecting means and to draw the inner mounting means towards the outer mounting means. The outer rings also rotate relative to the inner mounting means.
- [0023] In a particularly preferred embodiment the inner mounting means is an O-ring. Preferably the connecting means is a sleeve which is led from the first outer mounting means to the O-ring and from the O-ring to the second outer mounting means.
- [0024] In a preferred embodiment of the invention the device includes locking means for locking the first outer mounting means relative to the second outer mounting means.
- [0025] In one arrangement one of the outer mounting means is located or locatable within the other outer mounting means.
- [0026] Preferably the inner diameter of the sleeve is greater than or equal to the axial length of the sleeve.
- [0027] In a preferred arrangement the inner diameter of the sleeve is greater than the axial length of the sleeve by an amount less than the thickness of an average abdominal wall, which is typically 2 to 6 cm. This assists in achieving a retraction force.
- [0028] Preferably a substantially gas tight seal is formed between the outer mounting means on shortening of the length of the sleeve. Ideally, the sleeve extending between the first and second outer mounting means defines an inflatable space.
- [0029] In one embodiment of the invention the device includes a port for connection to an inflation means.
- [0030] The invention also provides a surgical device comprising:
- [0031] an inner mounting means for insertion through a wound opening;
  - [0032] a first outer mounting means;
  - [0033] a second outer mounting means; and
  - [0034] a sleeve of pliable material extending from the second outer mounting means to the inner mounting means and from the inner mounting means to the first outer mounting means.
- [0035] Preferably one or both of the first and second outer mounting means are movable relative to one another to adjust the diameter of the lumen defined by a twist in the sleeve extending therebetween.
- [0036] Ideally, the first and second outer mounting means are rotatable relative to one another.
- [0037] In one embodiment of the invention the sleeve is releasably mounted to the second outer mounting means for adjustment of the length of the sleeve.
- [0038] Preferably the second mounting means comprises a receiver and the sleeve is mounted or mountable to a ring which is releasably mounted to the receiver.
- [0039] In another embodiment of the invention the inner mounting means is configured to reduce the size thereof for ease of insertion into a wound opening.
- [0040] Typically in this case the inner mounting means comprises a ring which includes a hinge means for reducing the size of the ring.
- [0041] A device as claimed in claim 1 wherein the connecting means is translated to shorten the axial extent of the connecting means.
- [0042] A device as claimed in claim 23 wherein the connecting means comprises a sleeve which is translated by a drawstring mechanism.
- [0043] A device as claimed in claim 24 wherein the connecting means comprises a plurality of straps attached to the inner mounting means, the straps being pulled upwardly to shorten the axial extent of the connecting means.
- [0044] Typically the outer mounting means includes a holder for holding a surgical instrument
- [0045] The surgical device may form a wound retractor, a wound protector or a wound protector retractor.

#### BRIEF DESCRIPTION OF DRAWINGS

- [0046] The invention will be more clearly understood from the following description thereof given by way of example only with reference to the accompanying drawings, in which:
- [0047] FIG. 1 is a perspective view of a surgical device according to the invention;
- [0048] FIG. 2 is a cross sectional view of the device of FIG. 1;
- [0049] FIG. 3 is a cross sectional view of the device in one position of use;
- [0050] FIG. 4 is a cross sectional view of the device in another position of use;
- [0051] FIG. 5 is a top plan view of the device in the position of FIG. 4;
- [0052] FIGS. 6 and 7 are respectively perspective and cross sectional views illustrating a method of forming the device of FIGS. 1 to 5;

[0053] FIG. 8 is a perspective view of another surgical device according to the invention;

[0054] FIG. 9 is a cross sectional view of the device of FIG. 8 in one position of use;

[0055] FIG. 10 is a cross sectional view of the device of FIG. 8 in another position of use;

[0056] FIGS. 11 and 12 are cross sectional views of another surgical device according to the invention in different positions of use;

[0057] FIG. 13 is a plan view of the device of FIG. 11;

[0058] FIG. 14 is a cross sectional view of a further surgical device according to the invention;

[0059] FIGS. 15A and 15B are cross sectional views of the device of FIG. 14, in use;

[0060] FIG. 16 is plan view of the device of FIG. 14;

[0061] FIG. 17 is a cross section view of another surgical device of invention;

[0062] FIG. 18 is a plan view of the device of FIG. 17;

[0063] FIG. 19 is a cross sectional view of another surgical device of the invention;

[0064] FIG. 20 is a plan view of the device of FIG. 19;

[0065] FIGS. 21 is a cross sectional view of a further surgical device of the invention;

[0066] FIG. 22 is a cross sectional view of a still further surgical device of the invention;

[0067] FIG. 23 is plan view of the device of FIG. 22;

[0068] FIG. 24 is a perspective view of another surgical device of the invention;

[0069] FIG. 25 is a perspective view of the device of FIG. 24 being adjusted;

[0070] FIG. 26 is a side, partially cross sectional view of the device of FIGS. 24 and 25;

[0071] FIG. 27 is a view similar to FIG. 26 of the device partially disassembled;

[0072] FIG. 28 is a view similar to FIG. 26 with the device of FIG. 27 re-assembled;

[0073] FIG. 29 is a diagrammatic perspective view of another surgical device of the invention;

[0074] FIG. 30 is a perspective view of the device of FIG. 29 in a wound inserting configuration;

[0075] FIGS. 31 and 32 are respectively diagrammatic perspective and plan views of an inner ring part of the device of FIGS. 29 and 30;

[0076] FIG. 33 is a cross sectional view of two surgical devices ready for assembly;

[0077] FIG. 34 is a cross sectional view of the devices of FIG. 33, assembled;

[0078] FIG. 35 is a plan view of another surgical device according to the invention;

[0079] FIG. 36 is a cross sectional view on the line A-A in FIG. 35 with the device in position in an incision;

[0080] FIG. 37 is a plan view of the device of FIGS. 35 and 36 in another position of use; and

[0081] FIG. 38 is a cross sectional view on the line B-B of FIG. 37.

#### DETAILED DESCRIPTION

[0082] Referring to the drawings and initially to FIG. 1 to 7 thereof there is illustrated a surgical device, especially for use in laproscopic surgery. The device 1 in this case is used in surgery involving an incision 2 in a wall 3 of a patients abdomen. The wound is, in this case, both protected and retracted by the device 1 of the invention. Thus, the invention in this case provides a wound protector retractor.

[0083] The device 1 comprises an inner mounting means in the form of an O-ring 10 of flexible material such as of elastomeric material for insertion through the wound opening 2, an outer mounting means for mounting external of the wound opening 2 and a connecting means, in this case in the form of a sleeve 11 extending between the inner 10 and outer mounting means. The outer mounting means is movable, in this case rotatable, relative to the inner O-ring 10 to twist the sleeve 11 to form a centralised lumen 12 of reduced cross section and to shorten the axial extent of the sleeve 11. As the sleeve 11 is twisted the inner O-ring 10 is drawn upwardly from the inserted position illustrated in FIG. 3 to the in-use position illustrated in FIG. 4 in which the wound is sealed and a radial retraction force is applied to the wound. A surgeon inserts a sealed gloved hand/arm/instrument through the sealed and retracted wound to perform a surgical procedure within the abdomen.

[0084] In this preferred case the outer mounting means comprises a first outer mounting means in the form of a first annular ring 20 and a second outer mounting means in the form of a second annular ring 21. The sleeve 11 is of biocompatible pliable gas impermeable plastics material and is attached at one end to the ring 20 and at an opposite end to the ring 21. The sleeve 11 is connected to the ring 20, led over the O-ring 10 and back up for attachment to the ring 21 as best illustrated in FIG. 2.

[0085] In use, a surgeon makes an incision in the abdominal cavity and the O-ring 10 is flexed and inserted through the incision as illustrated in FIG. 3. The outer rings 20, 21 are then rotated relative to one another in the direction of the arrows A and B in FIG. 3. This relative rotation twists the sleeve 11 and shortens the sleeve until the device is in the operative position of FIG. 4. In this position the inner O-ring 10 is engaged against the inside of the interior of the anterior abdominal wall and the rings 21 and 22 are external of the wound opening with the sleeve 11 shortened in axial extent. The twisting of the sleeve 11 provides a central lumen 12 of reduced size, which depends on the degree of twist. A full 180° relative twist would result in closing down of the lumen. The reduced lumen 12 provides access for instruments and/or a surgeons arm while maintaining a wound seal.

[0086] Locking means of any suitable type may be provided to lock the rings 20, 21 together. The locking means may, for example comprise a releasable latching system such as a ratchet and pawl arrangement or the like.

[0087] Preferably a gas tight seal is formed between the rings 20, 21 in use. The sleeve in this case provides an

inflatable space **30** between the rings **20, 21** and the inner O-ring **10**. An inflation connection port may be provided in the device to facilitate inflation. On inflation, a wound engaging section **11a** of the sleeve is pushed radially outwardly to provide a highly efficient wound protector/seal and wound retractor. The inner sleeve section **11b** is inflated to further restrict the lumen **12** and provide highly efficient sealing engagement with a surgeons forearm, a device or an instrument inserted through the lumen.

[0088] For efficient sealing engagement it is preferred that the inner diameter (d) of the sleeve **11** is greater than or equal to the axial length (l) of the sleeve **11** as illustrated in FIG. 7. Preferably the inner diameter of the sleeve is greater than the axial length of the sleeve by an amount which is less than the thickness of an average abdominal wall. With this configuration on twisting of the sleeve **11**, sealing and retraction forces are applied to the wound opening.

[0089] The surgical device **1** may be formed from a cylindrical sleeve **50** of pliable plastic material attached to a pair of rings **20, 21** as illustrated in FIGS. 6 and 7. A flexible O-ring **10** is fitted over the sleeve **50**. The flexible sleeve **50** is then turned over on itself so that the O-ring **10** is confined between inner and outer sleeve sections **11a, 11b** and the rings **20, 21** are in the configuration illustrated in FIGS. 1 and 2.

[0090] The device of the invention applies a force to the wound edges to achieve adequate exposure without causing ischaemic injury to the wound edges. The device protects wound edges from cross infection or seeding by cancerous or otherwise malignant cells. Another advantage is that the device is sufficiently inexpensive that it can be disposed of after a single use thereby obviating the need for cleaning and sterilisation between use. In addition, the device is simple to place into a desired position in a wound or natural bodily opening and easy to remove, especially without negating the benefits gained from use of the device as a wound protector.

[0091] Referring to FIGS. 8 to 10 there is illustrated another surgical device **60** according to the invention. The device **60** is similar to the device **1** and like parts are assigned the same reference numerals. In this case the sleeve **61** is a single wall sleeve and there is only one outer mounting ring **62**. On rotation of the outer ring **62** relative to the inner ring **10** a twist is formed in the sleeve which is shortened, drawing the inner ring **10** upwardly against the interior of the anterior abdominal wall as illustrated in FIGS. 9 and 10.

[0092] It will be appreciated that the inner O-ring may be fixed, for example, by adhesives to the sleeve of the surgical device. It will also be appreciated that one or more of the mounting means may be shaped to positively engage with tissue. For example, the mounting means may include tissue-engaging projections to lock the mounting means in position.

[0093] It will be appreciated that while for efficient retraction and wound protection it is preferred that the connecting means between the outer and inner mounting means is in the form of a sleeve of pliable material, the connecting means may be discontinuous. For example the sleeve may be in the form of elongate strips or the like.

[0094] Referring to FIGS. 11 to 13 there is illustrated another surgical device **70** according to the invention. In this

case the connecting means comprises a plurality of straps **71** which are drawn upwardly to shorten the axial extent and to form a wound retractor. The straps **71** are retained in the shortened configuration illustrated by any suitable locking means such as by wedge elements **72**. In this case an iris diaphragm type device **80** is provided in the wound opening which is inflatable from the rest configuration illustrated in FIG. 11 to the pressurised inflated configuration illustrated in FIG. 12.

[0095] Referring to FIGS. 14 to 16 there is illustrated another device **85** according to the invention in which the connecting means is defined by a plurality of straps **86** which are movable between an inner mounting ring **83** and an outer mounting ring **84** by buckle devices **87** from the initial position illustrated in FIG. 15B to the wound retracting position of FIG. 15A. The inner ring **83** is first inserted though the incision. The outer ring **82** is then brought down to skin level by taking up the slack in the straps **86**. To achieve the retraction effect the straps **86** are pulled taut causing the wound edge to be displaced out from the centerpoint of the wound. The straps **86** may be adjusted until optimum retraction is achieved. Tension in the straps **86** is maintained by the buckles **86** which may hold the strap **86** taut either by friction or using a clasp mechanism.

[0096] Referring to FIGS. 17 and 18 another surgical device **90** similar to the device **85** is illustrated. In this case the inner and outer mounting rings **82, 83** are of oval shape in transverse cross section to smooth the movement of the straps **86**. This device operates in a similar manner to the device **85**.

[0097] Referring to FIGS. 19 and 20 there is illustrated another surgical device **93** which has single legged straps **94**. This device operates in a similar manner to devices **85** and device **90**. In this case straps **94** do not loop around the inner ring **83** but are directly attached to it.

[0098] Referring to FIG. 21 there is illustrated a further surgical device **95** having straps **96** which are locked in position by a locking mechanism. The locking mechanism comprises a wedge **97** inserted into a hole through which the strap **96** passes to hold the strap **96** in position by friction. A ratchet mechanism may also be used or some other adjustable locking mechanism to hold the strap in position.

[0099] The device **98** illustrated in FIGS. 22 and 23 is similar to the device of FIG. 21 except that a different construction of wedge or ratchet **99** is used to lock the straps in position.

[0100] Referring to FIGS. 24 to 26 there is illustrated another surgical device according to the invention. In this case the surgical device is a wound protector retractor **200** of similar construction as that described above with reference to FIGS. 1 to 10. The device **1** comprises an inner mounting means in the form of a first O-ring **201**, a first outer mounting means in the form of a second O-ring **202** mounted in a first receiver **203**, and a second mounting means in the form of a third O-ring **205** mounted in a second receiver **206**. The receivers **203, 206** are in this case interconnectable as illustrated and a fourth O-ring **207** is provided between the receivers **203, 206** on assembly.

[0101] A sleeve **210** of flexible pliable plastics material extends from the second outer receiver **206** to the inner O-ring **201** and from the inner O-ring **201** to the first outer

receiver **203**. The receivers **203**, **206** are de-mountable as illustrated in **FIG. 25** to facilitate relative rotation therebetween in the direction of the arrows to vary the degree of twist in the sleeve **210**.

[**0102**] Referring to **FIGS. 27 and 28** there is illustrated another surgical device **220** which is similar to the device of **FIGS. 24 to 26** and like parts are assigned the same reference numerals. In this case the O-ring **205** is de-mountable from the receiver **206** to facilitate length adjustment of the sleeve **210**. On removal of the O-ring **205** the sleeve **210** is adjusted to a desired length *d*. In this way a single device **220** may be used for a variety of thickness of abdomens. The lumen diameter defined by the twist does not need to be changed to cater for a range of abdomen sizes. The excess sleeve may be cut off or wound around the O-ring seal **205**.

[**0103**] Referring now to **FIGS. 29 to 32** there is illustrated part **230** of another surgical device according to the invention which is similar to the devices of **FIGS. 24 to 28** and like parts are assigned the same reference numerals. An inner mounting means **231** is configured to reduce the size thereof for ease of insertion into a wound opening. In this case the inner mounting means **231** is in the form of a split ring which is hinged at **232** to facilitate a reduction in the diameter of the ring **231** as illustrated. It will of course be appreciated that the hinge may be integrally formed and indeed, there may be a number of such hinges.

[**0104**] Referring to **FIGS. 33 and 34** there is illustrated an assembly of two surgical devices **250**, **260**. The device **250** is a forearm seal and the device **260** is a wound protector retractor which is assembled to an outer sealing device **250**. The sealing device **250** provides an outer sealed access port through which a surgeon may insert his forearm or for insertion of an instrument or the like.

[**0105**] Referring to **FIGS. 35 to 38** there is illustrated another surgical device **300** according to the invention. The device **300** is a wound protector retractor similar to those described above. In this case the wound protector retractor **300** comprises an inner ring **301** of semi-rigid elastomeric material and an outer ring **302** which is of similar material. A sleeve **303** of pliable material extends between the rings **301**, **302**. Drawstrings **305** are fitted to the sleeve **303**, the drawstrings being pulled outwardly in the direction of the arrows to pull the sleeve **303** upwardly to tighten in the incision and provide a wound protector and retractor.

[**0106**] Reference is also made to appropriate alternatives and modifications which are outlined in our parallel applications referenced **ATRO1/C**, **ATRO12/C**, **ATRO14/C**, **ATRO15/C**, **ATRO16/C**, **ATRO17/C**, the entire contents of which are incorporated herein by reference.

[**0107**] The invention is not limited to the embodiments hereinbefore described which may be varied in construction and detail.

**1.** A surgical device comprising:

- an inner mounting means for insertion through a wound opening;
- a first outer mounting means for mounting external of a wound opening; and
- connecting means extending between the inner and outer mounting means;

the connecting means being movable to shorten the axial extent of the connecting means.

**2.** A surgical device as claimed in claim 1 wherein the outer mounting means is movable relative to the inner mounting means to twist the connecting means to form a lumen of reduced cross section and to shorten the axial extent of the connecting means.

**3.** A device as claimed in claim 2 wherein the outer mounting means is rotatable relative to the inner mounting means to twist the connecting means.

**4.** A device as claimed in any preceding claim wherein the connecting means is a sleeve of pliable material extending between the inner and outer mounting means.

**5.** A device as claimed in any preceding claim including a second outer mounting means, the connecting means extending between the first outer mounting means, the inner mounting means, and the second outer mounting means.

**6.** A device as claimed in claim 5 wherein the first and second outer mounting means are rotatable relative to one another to twist the connecting means and to draw the inner mounting means towards the outer mounting means.

**7.** A device as claimed in claim 5 or 6 wherein the inner mounting means is an O-ring.

**8.** A device as claimed in claim 7 wherein the connecting means is a sleeve which is led from the first outer mounting means to the O-ring and from the O-ring to the second outer mounting means.

**9.** A device as claimed in any of claims 5 to 8 including locking means for locking the first outer mounting means relative to the second outer mounting means.

**10.** A device as claimed in any of claims 5 to 9 wherein one of the outer mounting means is located or locatable within the other outer mounting means.

**11.** A device as claimed in any of claims 4 to 10 wherein the inner diameter of the sleeve is greater than or equal to the axial length of the sleeve.

**12.** A device as claimed in claim 11 wherein the inner diameter of the sleeve is greater than the axial length of the sleeve by an amount which is less than the thickness of an average abdominal wall.

**13.** A device as claimed in any of claims 5 to 12 wherein a substantially gas tight seal is formed between the outer mounting means on shortening of the length of the sleeve.

**14.** A device as claimed in claim 13 wherein the sleeve extending between the first and second outer mounting means defines an inflatable space.

**15.** A device as claimed in claim 14 wherein the device includes a port for connection to an inflation means.

**16.** A device as claimed in any preceding claim comprising:

- an inner mounting means for insertion through a wound opening;
- a first outer mounting means;
- a second outer mounting means; and

a sleeve of pliable material extending from the second outer mounting means to the inner mounting means and from the inner mounting means to the first outer mounting means.

**17.** A device as claimed in claim 16 wherein one or both of the first and second outer mounting means are movable relative to one another to adjust the diameter of the lumen defined by a twist in the sleeve extending therebetween.

**18.** A device as claimed in claim 17 wherein the first and second outer mounting means are rotatable relative to one another.

**19.** A device as claimed in any of claims 16 to 18 wherein the sleeve is releasably mounted to the second outer mounting means for adjustment of the length of the sleeve.

**20.** A device as claimed in claim 19 wherein the second mounting means comprises a receiver and the sleeve is mounted or mountable to a ring which is releasably mounted to the receiver.

**21.** A device as claimed in any of claims 16 to 20 wherein the inner mounting means is configured to reduce the size thereof for ease of insertion into a wound opening.

**22.** A device as claimed in claim 21 wherein the inner mounting means comprises a ring which includes a hinge means for reducing the size of the ring.

**23.** A device as claimed in claim 1 wherein the connecting means is translated to shorten the axial extent of the connecting means.

**24.** A device as claimed in claim 23 wherein the connecting means comprises a sleeve which is translated by a drawstring mechanism.

**25.** A device as claimed in claim 24 wherein the connecting means comprises a plurality of straps attached to the inner mounting means, the straps being pulled upwardly to shorten the axial extend of the connecting means.

**26.** A device as claimed in claim 25 including an iris diaphragm connected to the straps.

**27.** A device as claimed in any preceding claim wherein the outer mounting means includes a holder for holding a surgical instrument.

**28.** A surgical device substantially as hereinbefore described with reference to the accompanying drawings.

**29.** A surgical device as claimed in any preceding claim forming a wound retractor.

**30.** A surgical device as claimed in any of claims 1 to 28 forming a wound protector.

**31.** A surgical device as claimed in any preceding claim forming a wound protector retractor.

**32.** A wound protector substantially as hereinbefore described with reference to the accompanying drawings.

**33.** A wound retractor substantially as hereinbefore described with reference to the accompanying drawings.

**34.** A wound protector retractor substantially as hereinbefore described with reference to the accompanying drawings.

**35.** A device as claimed in any preceding claim including an attachment means for attaching the device to another device.

**36.** A device as claimed in claim 35 wherein the other device is another surgical device.

**37.** A device as claimed in claim 36 wherein the other device is a wound protector, wound retractor, wound protector retractor or a forearm seal.

\* \* \* \* \*