

No. 816,426.

PATENTED MAR. 27, 1906.

J. P. BREW & E. P. SUITER.
REVOLVING DRUM SCREEN.

APPLICATION FILED JUNE 9, 1905.

3 SHEETS—SHEET 1.

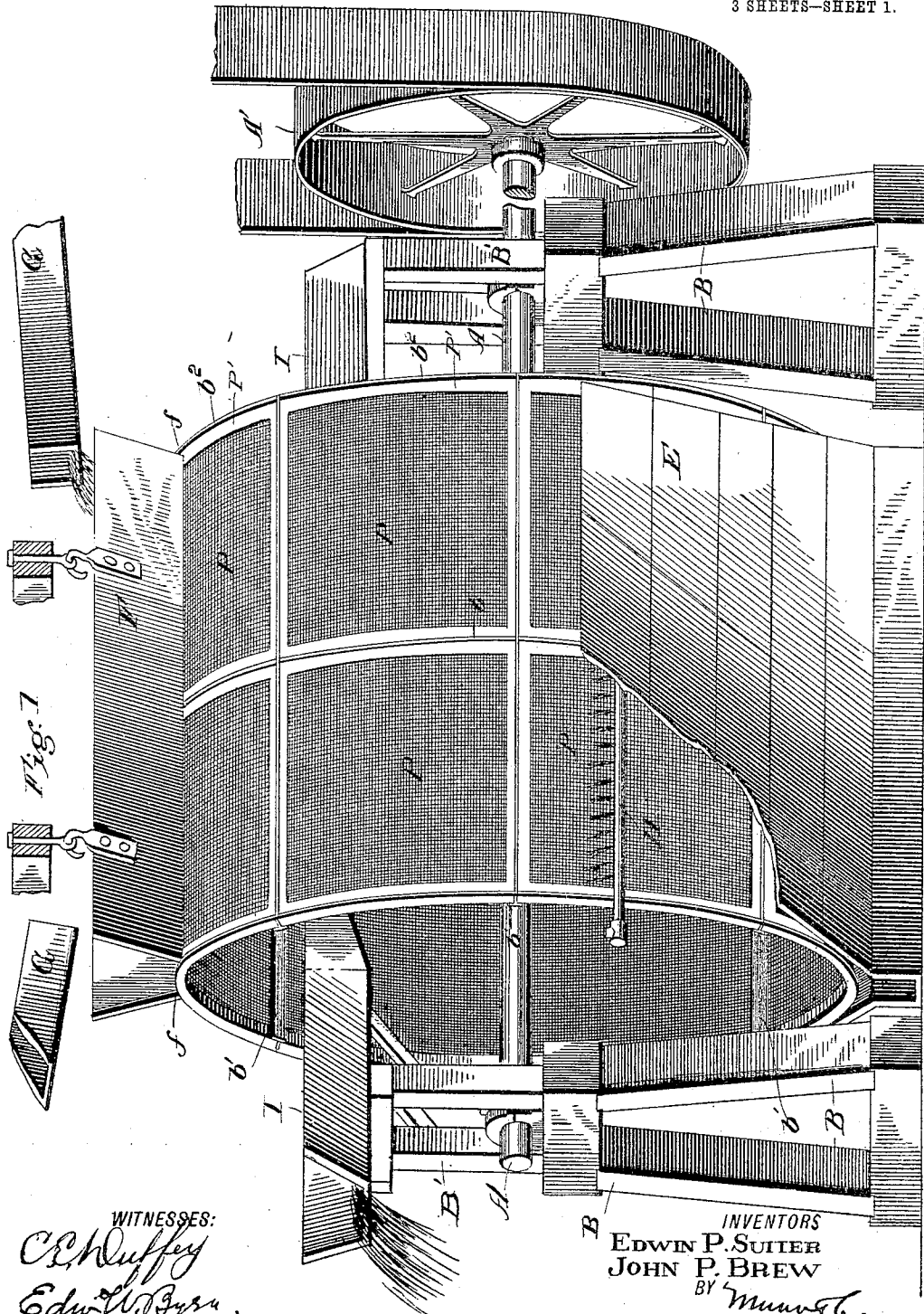

Fig. 1

WITNESSES:
C. H. Duffey
Edw. W. Byers

INVENTORS
EDWIN P. SUITER
JOHN P. BREW
BY *Munn & Co.*
ATTORNEYS

No. 816,426.

PATENTED MAR. 27, 1906.

J. P. BREW & E. P. SUITER.
REVOLVING DRUM SCREEN.

APPLICATION FILED JUNE 9, 1905.

3 SHEETS—SHEET 2.

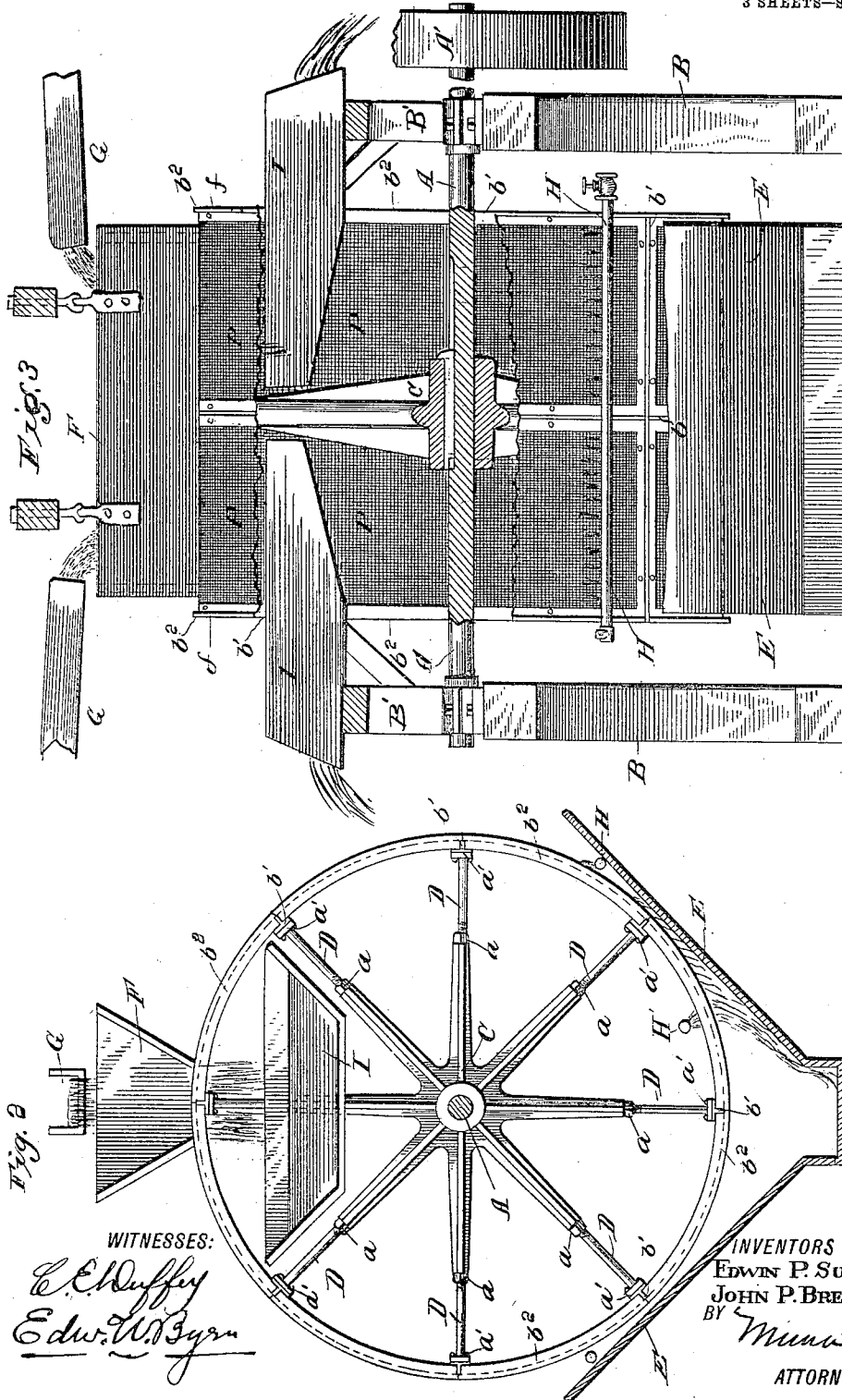

WITNESSES:

E. C. Duffey
Edw. W. Byrne

INVENTORS
EDWIN P. SUITER
JOHN P. BREW

BY *Minna Co.*
ATTORNEYS

No. 816,426.

PATENTED MAR. 27, 1906.

J. P. BREW & E. P. SUITER.
REVOLVING DRUM SCREEN.

APPLICATION FILED JUNE 9, 1905.

3 SHEETS—SHEET 3.

Fig 4

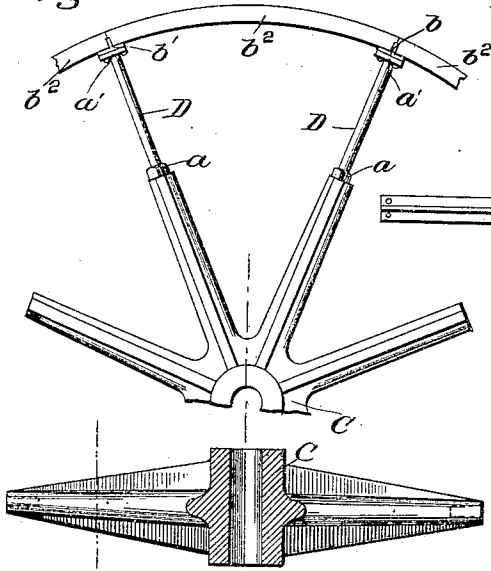

Fig. 5^a

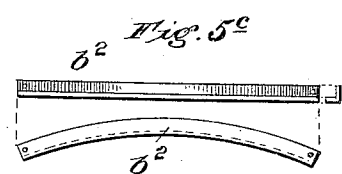
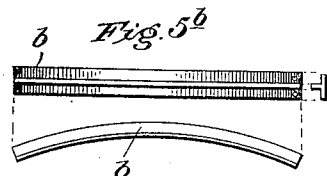
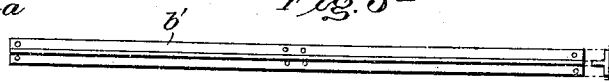

Fig 5

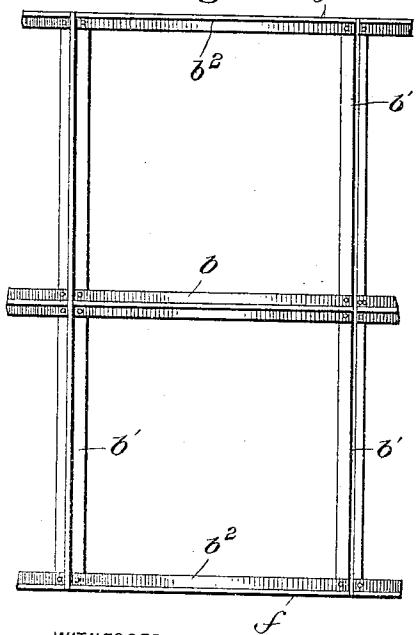
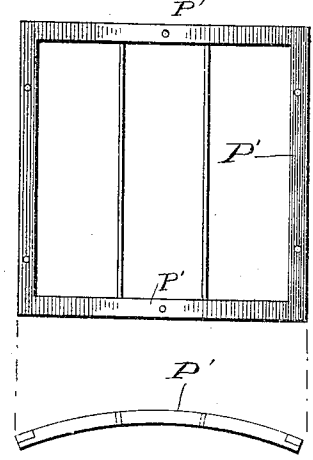

Fig. 5^d



WITNESSES:

C. Cluff
Edw. W. Byrn.

INVENTORS

EDWIN P. SUITER
JOHN P. BREW

Munn & Co.
ATTORNEYS

UNITED STATES PATENT OFFICE.

JOHN P. BREW AND EDWIN P. SUITER, OF BASIN, MONTANA.

REVOLVING DRUM-SCREEN.

No. 816,426.

Specification of Letters Patent.

Patented March 27, 1906.

Application filed June 9, 1905. Serial No. 264,421.

To all whom it may concern:

Be it known that we, JOHN P. BREW and EDWIN P. SUITER, citizens of the United States, and residents of Basin, in the county of Jefferson and State of Montana, have invented certain new and useful Improvements in Revolving Drum-Screens, of which the following is a specification.

Our invention is in the nature of a revolving drum-screen designed to be used for the purpose of screening the slime-water of the concentrator either before or after it is worked on the concentrator-jigs, the slime-water being worked over for whatever value it may still contain.

It consists in the novel construction and arrangement of a revolving drum whose periphery is formed of screening-wire in which the materials to be screened are applied to the outer surface of the drum and pass through the screening-wire to troughs inside of the drum and in which the refuse matter clinging to the wire mesh is constantly removed and the screen maintained in a clean and effective condition.

Figure 1 is a perspective view of the revolving drum-screen with a portion of its housing broken away. Fig. 2 is an end elevation of the drum, partly in section. Fig. 3 is a side elevation of the drum with part of the housing broken away and the upper part of the drum in section. Fig. 4 is a side and sectional view of the central spider-frame for supporting the drum. Fig. 5 is a detail showing the skeleton frame of the drum, and Figs. 5^a, 5^b, 5^c, and 5^d are details of said skeleton frame.

Referring to Fig. 1, A represents the main shaft, supported in bearings mounted on standards B at a point entirely outside of the drum. The shaft is provided with a pulley-wheel A', by which it is rotated. The screening-drum is rigidly attached to the shaft A and has its periphery composed of screening material, as hereinafter described in detail. Said drum is to be made from six to fifteen feet in diameter, according to the quantity of material to be screened, and it is designed to revolve slowly at a speed of from twenty to thirty feet per minute at the rim. The lower portion of the drum is contained in a trough-like housing E. Above the drum and in close proximity to its outer surface is suspended a stationary hopper F, into which the slime-water to be screened is discharged from two spouts G G—one on each side of the

drum. As the slime-water passes through the wire mesh of the drum it is received into the two troughs I I, mounted on supports B'. These troughs extend from a point near the middle of the drum and incline downwardly and outwardly on each side of the drum to a point beyond the ends of the drum.

The drum is formed of a single central spider frame, (seen in Fig. 2,) and its ends are entirely open to allow the protrusion there-through of the discharge-spouts I I, (seen in Fig. 1,) so that the drum may freely rotate without the interference of any radial spokes at the ends thereof. The central frame of the drum consists of the hub C, having radial arms formed integrally therewith, the outer ends of which are bored and screw-threaded to receive the inner screw-threaded ends of a series of spokes D, which inner ends of such spokes are tightened by means of jam-nuts *a*. The outer ends of these spokes D are formed with flanges, which are bolted to the central circular rib member of the drum.

The periphery of the drum is composed of a series of rectangular panels P, as seen in Figs. 1 and 3, which panels are composed of sections of wire-netting distended upon the curved wooden frames P', Fig. 5^d, which are curved to constitute the periphery of the drum. The wire-screen panels, as composed of these rectangular frames P' with outer coverings of wire-cloth, are detachable from and seated in a skeleton frame forming the periphery of the drum, the particular construction of which skeleton frame is shown in Figs. 5, 5^a, to 5^c. It consists of T-irons *b'*, which extend across the drum longitudinally and parallel to its axis. These T-iron members *b'* are shown in detail in Fig. 5^a. On the middle line of the drum between these longitudinal T-irons *b'* are other T-irons *b*. (Shown in Fig. 5^b in detail.) These are curved to correspond with the periphery of the drum. At the outer ends of the T-irons *b'* are marginal members *b*². These are in like manner curved to correspond to the periphery of the drum, as shown in Fig. 5^c, and they are formed as angle-bars and are bolted to the ends of the longitudinal members *b'*. The spokes D of the central frame have flanged heads *a'* at their outer ends. These heads are bolted to both longitudinal T-irons *b'* and the circular T-irons *b* by the same bolts.

The marginal rings composed of the series of angle-bars *b*² have standing flanges *f*,

which rise above the level of the screen-wire sufficiently to prevent the water received from the hopper F from spilling over the edges of the drum.

5 At a point within the housing E of the drum is arranged a horizontal spray-pipe H, perforated with holes and through which a current of water is flowed continuously, being discharged in an upward direction against the
10 screen-wire of the drum to clean the same of all fibrous and choking matters, so that as the drum revolves the wire mesh passes again beneath the hopper F in a perfectly clean condition with its interstices open and free to effect a perfect screening of the slime-water.
15 A second spray-pipe H' (see Fig. 2) may also be arranged inside the screen.

The operation of this revolving screen is as follows: The slime-water or water to be
20 screened is delivered by means of spouts G into the hopper F and is discharged therefrom upon the exterior of the revolving drum at the upper edge of the same. The screened water after passing through the wire mesh is
25 caught in the troughs I on the inside of the drum and discharged on either side of the drum downwardly and outwardly through the ends of the same. The coarse material is arrested on the outer surface of the screen and
30 as it passes down to the spray-pipe H is washed off therefrom and delivered into the bottom of the waste-box at the bottom of the housing E.

Among the advantages of our invention we
35 claim great simplicity and cheapness of construction, together with strength, lightness, and longevity. Its sectional character also adapts its parts to be easily transported at a minimum expense and to be packed into
40 compact limits. As the drum is supported entirely by the central spider-frame bearing in one vertical plane on the main shaft A, such shaft is made of a large size, so as to hold the drum firm and steady while the body or flow
45 of minerals and slime-water is pouring down on the top of the same. The hub, with the radial arms cast on solid and with a taper design, takes out all spring or sway from the frame, imparting stiffness and rigidity to the
50 drum. The detachable short spokes make it easy to remove and repair the frame. The detachable panels P also permit any section of defective screening-wire to be quickly and easily removed and a new one substituted
55 therefor. The simple manner of conducting away the screened slime-water through the open ends of the drum keeps the bearings of the drum free from foul matters and from all wear incident to the same. The feed of the
60 slime-water being from the opposite sides of the drum and the discharge being from both ends of the drum, the drum is enabled to do a large amount of work. Another advan-

tage of my construction of revolving drum is that, although supported only at a single central point, the discharge-spouts extending
65 from the center of the opposite ends of the drum and the discharge of material on the drum on both sides of its center cause it to be exactly balanced, so as to involve no unequal
70 strains on the centrally-supported drum.

Having thus described our invention, what we claim as new, and desire to secure by Letters Patent, is—

1. A revolving screen comprising a central shaft, a drum having a peripheral covering
75 of screen material and open ends, a central supporting-frame connecting the shaft to the drum and consisting of a central spider with radial arms rigidly attached to the shaft
80 and having adjustable spoke ends, an external hopper placed above the drum for feeding the material on the outer surface of the same and two reversely-inclined discharge-troughs arranged in the drum and extending from the
85 center outwardly and downwardly through the open ends of the same and external supports for these discharge-troughs.

2. A revolving screen comprising a drum
90 having a peripheral covering of screen material with open ends, two feed-troughs emptying externally upon opposite ends of the drum, a single supporting-frame, arranged centrally in the drum, a shaft rigidly connected to said central frame, and two discharge-troughs arranged upon external
95 supports and projecting into opposite ends of the drum to balance the strain on the centrally-supported drum.

3. A revolving screen comprising a shaft, a
100 drum with peripheral screen and open ends and outwardly-projecting flanges at each end, a central support for the drum consisting of a spider-frame with radial spokes, a hopper placed exteriorly above the drum, two
105 troughs arranged inside the drum beneath the hopper on opposite sides of the central support and extending downwardly and outwardly through the open ends of the drum, a spray-pipe arranged outside the drum to play
110 on the same, and a housing with waste-box inclosing the lower portion of the drum.

4. A revolving screen comprising a shaft, a drum having a peripheral covering of screen
115 material, a central spider-frame, the drum-frame composed of panel-seats made of separate longitudinal T-bars and circular T-bars, and spokes connected to the central spider-frame and having flanged outer ends bolted to both the longitudinal and cross members
120 of the T-bars.

JOHN P. BREW.
EDWIN P. SUITER.

Witnesses:

DAVID BEVAN,
JAMES H. CHRISTIE.